



Compliance Certification Services Inc.

Report No.: T130605L06-RP1

FCC ID: B9Q-MYMET30019

Date of Issue: July 2, 2013

FCC 47 CFR PART 15 SUBPART C

TEST REPORT

For

myMET(Hand held Bluetooth Connected Wind Meter)

Model: 30019

Trade Name: WeatherHawk myMET

Issued to

**Campbell Scientific Inc
815 West 1800 North, Logan UT 84321, USA**

Issued by

**Compliance Certification Services Inc.
No.81-1, Lane 210, Bade 2nd Rd., Lujhu Township,
Taoyuan County 33841, Taiwan, R.O.C.**

TEL: 886-3-324-0332

FAX: 886-3-324-5235

<http://www.ccsrf.com>

service@ccsrf.com



Testing Laboratory
0363

Note: *This report shall not be reproduced except in full, without the written approval of Compliance Certification Services Inc. This document may be altered or revised by Compliance Certification Services Inc. personnel only, and shall be noted in the revision section of the document. The client should not use it to claim product endorsement by TAF, A2LA, NIST or any government agencies. The test results in the report only apply to the tested sample.*



Compliance Certification Services Inc.

Report No.: T130605L06-RP1 FCC ID: B9Q-MYMET30019 Date of Issue: July 2, 2013

Revision History

Rev.	Issue Date	Revisions	Effect Page	Revised By
00	July 2, 2013	Initial Issue	ALL	Landy Huang



TABLE OF CONTENTS

1	TEST RESULT CERTIFICATION	4
2	EUT DESCRIPTION.....	5
3	TEST METHODOLOGY.....	6
3.1.	EUT CONFIGURATION.....	6
3.2.	EUT EXERCISE	6
3.3.	GENERAL TEST PROCEDURES	6
3.4.	FCC PART 15.205 RESTRICTED BANDS OF OPERATIONS	7
3.5.	DESCRIPTION OF TEST MODES	8
4	INSTRUMENT CALIBRATION	9
4.1.	MEASUREMENT EQUIPMENT USED	9
4.2.	MEASUREMENT UNCERTAINTY	10
5	FACILITIES AND ACCREDITATIONS	11
5.1.	FACILITIES	11
5.2.	EQUIPMENT	11
5.3.	TABLE OF ACCREDITATIONS AND LISTINGS.....	12
6	SETUP OF EQUIPMENT UNDER TEST	13
6.1.	SETUP CONFIGURATION OF EUT	13
6.2.	SUPPORT EQUIPMENT	13
7	FCC PART 15.247 REQUIREMENTS.....	14
7.1.	6DB BANDWIDTH	15
7.2.	PEAK POWER.....	18
7.3.	AVERAGE POWER.....	22
7.4.	BAND EDGES MEASUREMENT.....	25
7.5.	PEAK POWER SPECTRAL DENSITY.....	32
7.6.	SPURIOUS EMISSIONS	36
7.7.	POWERLINE CONDUCTED EMISSIONS.....	46
8	PHOTOGRAPHS OF TEST SETUP	47
	APPENDIX 1: PHOTOGRAPHS OF EUT	50



1 TEST RESULT CERTIFICATION

Applicant: **Campbell Scientific Inc**
815 West 1800 North, Logan UT 84321, USA

Manufacturer: **AZ Instrument Corp.**
DRAKE CHAMBERS,ROAD TOWN,TORTOLA,BRITISH VIRGIN ISLANDS

Equipment Under Test: myMET(Hand held Bluetooth Connected Wind Meter)

Trade Name: WeatherHawk myMET

Model: 30019

Date of Test: June 20 ~ 22, 2013

APPLICABLE STANDARDS	
STANDARD	TEST RESULT
FCC Part 15 Subpart C/Oct. 2012	No non-compliance noted

We hereby certify that:

The above equipment was tested by Compliance Certification Services Inc. The test data, data evaluation, test procedures, and equipment configurations shown in this report were made in accordance with the procedures given in ANSI C63.4 and the energy emitted by the sample EUT tested as described in this report is in compliance with the requirements of FCC Rules Part 15.207, 15.209, 15.247.

The test results of this report relate only to the tested sample EUT identified in this report.

Approved by:

Reviewed by:

Stan Lin
Section Manager

Angel Hu
Section Manager



2 EUT DESCRIPTION

Product	myMET(Hand held Bluetooth Connected Wind Meter)		
Trade Name	WeatherHawk myMET		
Model Number	30019		
Model Name Discrepancy	N/A		
Identify Number	T130605L01		
Received Date	June 5, 2013		
EUT Power Rating	6VDC From Battery		
RF Module	TEXAS INSTRUMENTS	Model	CC2541
Operating Frequency Range	2402 ~ 2480 MHz		
Transmit Power	1.75 dBm (0.0015W)		
Modulation Technique	GFSK (1Mbps)		
Number of Channels	40 Channels		
Antenna Specification	PCB Antenna / Gain: 4.33dBi		

Remark:

1. The sample selected for test was production product and was provided by manufacturer.
2. This submittal(s) (test report) is intended for FCC ID: **B9Q-MYMET30019** filing to comply with Section 15.207, 15.209 and 15.247 of the FCC Part 15, Subpart C Rules.



3 TEST METHODOLOGY

The tests documented in this report were performed in accordance with ANSI C63.4 and FCC CFR 47 15.207, 15.209 and 15.247.

3.1. EUT CONFIGURATION

The EUT configuration for testing is installed on RF field strength measurement to meet the Commissions requirement and operating in a manner that intends to maximize its emission characteristics in a continuous normal application.

3.2. EUT EXERCISE

The EUT was operated in the engineering mode to fix the TX frequency that was for the purpose of the measurements.

According to its specifications, the EUT must comply with the requirements of the Section 15.207, 15.209 and 15.247 under the FCC Rules Part 15 Subpart C.

3.3. GENERAL TEST PROCEDURES

Conducted Emissions

The EUT is placed on the turntable, which is 0.8 m above ground plane. According to the requirements in Section 13.1.4.1 of ANSI C63.4 (2009) Conducted emissions from the EUT measured in the frequency range between 0.15 MHz and 30MHz using CISPR Quasi-peak and average detector modes.

Radiated Emissions

The EUT is placed on a turn table, which is 0.8 m above ground plane. The turntable shall rotate 360 degrees to determine the position of maximum emission level. EUT is set 3m away from the receiving antenna, which varied from 1m to 4m to find out the highest emission. And also, each emission was to be maximized by changing the polarization of receiving antenna both horizontal and vertical. In order to find out the maximum emissions, exploratory radiated emission measurements were made according to the requirements in Section 13.1.4.1 of ANSI C63.4.



3.4. FCC PART 15.205 RESTRICTED BANDS OF OPERATIONS

(a) Except as shown in paragraph (d) of this section, only spurious emissions are permitted in any of the frequency bands listed below:

MHz	MHz	MHz	GHz
0.090 - 0.110	16.42 - 16.423	399.9 - 410	4.5 - 5.15
¹ 0.495 - 0.505	16.69475 - 16.69525	608 - 614	5.35 - 5.46
2.1735 - 2.1905	16.80425 - 16.80475	960 - 1240	7.25 - 7.75
4.125 - 4.128	25.5 - 25.67	1300 - 1427	8.025 - 8.5
4.17725 - 4.17775	37.5 - 38.25	1435 - 1626.5	9.0 - 9.2
4.20725 - 4.20775	73 - 74.6	1645.5 - 1646.5	9.3 - 9.5
6.215 - 6.218	74.8 - 75.2	1660 - 1710	10.6 - 12.7
6.26775 - 6.26825	108 - 121.94	1718.8 - 1722.2	13.25 - 13.4
6.31175 - 6.31225	123 - 138	2200 - 2300	14.47 - 14.5
8.291 - 8.294	149.9 - 150.05	2310 - 2390	15.35 - 16.2
8.362 - 8.366	156.52475 -	2483.5 - 2500	17.7 - 21.4
8.37625 - 8.38675	156.52525	2655 - 2900	22.01 - 23.12
8.41425 - 8.41475	156.7 - 156.9	3260 - 3267	23.6 - 24.0
12.29 - 12.293	162.0125 - 167.17	3332 - 3339	31.2 - 31.8
12.51975 - 12.52025	167.72 - 173.2	3345.8 - 3358	36.43 - 36.5
12.57675 - 12.57725	240 - 285	3600 - 4400	(²)
13.36 - 13.41	322 - 335.4		

¹ Until February 1, 1999, this restricted band shall be 0.490-0.510 MHz.

² Above 38.6

(b) Except as provided in paragraphs (d) and (e), the field strength of emissions appearing within these frequency bands shall not exceed the limits shown in Section 15.209. At frequencies equal to or less than 1000 MHz, compliance with the limits in Section 15.209 shall be demonstrated using measurement instrumentation employing a CISPR quasi-peak detector. Above 1000 MHz, compliance with the emission limits in Section 15.209 shall be demonstrated based on the average value of the measured emissions. The provisions in Section 15.35 apply to these measurements.



3.5. DESCRIPTION OF TEST MODES

The EUT (model: 30019) had been tested under operating condition, using new battery during the test and had been reported as worst case on this test report.

Test program used to control the EUT for staying in continuous transmitting mode was programmed.

After verification, all tests were carried out with the worst case test modes as shown below except radiated spurious emission below 1GHz and power line conducted emissions below 30MHz, which worst case was in normal link mode only.

Channel Low (2402MHz), Mid (2440MHz) and High (2480MHz) with 1Mbps data rate was chosen for full testing.

The field strength of spurious emission was measured in the following position: EUT stand-up position (Y axis), lie-down position (X, Z axis). The worst emission was found in lie-down position (Z axis) and the worst case was recorded.



4 INSTRUMENT CALIBRATION

The measuring equipment, which was utilized in performing the tests documented herein, has been calibrated in accordance with the manufacturer's recommendations for utilizing calibration equipment, which is traceable to recognized national standards.

4.1. MEASUREMENT EQUIPMENT USED

Equipment Used for Emissions Measurement

Conducted Emissions Test Site				
Name of Equipment	Manufacturer	Model	Serial Number	Calibration Due
Spectrum Analyzer	Agilent	E4446A	MY48250064	01/13/2014
Spectrum Analyzer	Agilent	N9010A	MY52220817	02/22/2014
Power meter	Anritsu	ML2495A	1033009	08/19/2013
Power Sensor	Anritsu	MA2411B	0917221	08/19/2013

3M Semi Anechoic Chamber				
Name of Equipment	Manufacturer	Model	Serial Number	Calibration Due
Spectrum Analyzer	Agilent	E4446A	MY48250064	01/13/2014
Pre-Amplifier	HP	8447D	2944A06530	01/02/2014
Pre-Amplifier	EMEC	EM01M26G	060570	10/30/2013
Pre-Amplifier	MITEQ	AMF-6F-26040 0-40-8P	985646	08/06/2013
EMI Test Receiver	SCHAFFNER	SCR 3501	430	03/24/2014
Loop Antenna	EMCO	6502	2356	06/12/2014
Bilog Antenna	SCHWAZBECK	VULB9160	3084	09/26/2013
Horn Antenna	EMCO	3115	00022250	08/04/2013
Horn Antenna	EMCO	3116	00026370	10/07/2013
Antenna Tower	CCS	CC-A-1F	N/A	N.C.R
Turn Table	CCS	CC-T-1F	N/A	N.C.R
Test S/W	EZ-EMC			

Powerline Conducted Emissions Test Site				
Name of Equipment	Manufacturer	Model	Serial Number	Calibration Due
N/A				

NOTE: 1. The calibration interval of the above test instruments is 12 months and the calibrations are traceable to NML/ROC and NIST/USA.
 2. N.C.R = No Calibration Request.



4.2. MEASUREMENT UNCERTAINTY

For the test methods, according to the present document, the measurement uncertainty figures shall be calculated in accordance with TR 100 028-1 [2] and shall correspond to an expansion factor (coverage factor) $k = 1,96$ or $k = 2$ (which provide confidence levels of respectively 95 % and 95,45 % in the case where the distributions characterizing the actual measurement uncertainties are normal (Gaussian)).

Table 6 is based on such expansion factors.

Table 6: Maximum measurement uncertainty

Parameter	Uncertainty
RF frequency	$\pm 1 \cdot 10^{-5}$
Total RF power conducted	$\pm 1,5$ dB
RF power density, conducted	± 3 dB
Spurious emissions, conducted	± 3 dB
All emissions, radiated	± 6 dB
Humidity	± 5 %
Temperature	$\pm 1^{\circ}\text{C}$
DC and low frequency voltages	± 3 %
Powerline Conducted Emission	± 2.0518



5 FACILITIES AND ACCREDITATIONS

5.1. FACILITIES

All measurement facilities used to collect the measurement data are located at

- No.199, Chunghsen Road, Hsintien City, Taipei Hsien, Taiwan, R.O.C.
Tel: 886-2-2217-0894 / Fax: 886-2-2217-1029
- No.11, Wugong 6th Rd., Wugu Industrial Park, Taipei Hsien 248, Taiwan
Tel: 886-2-2299-9720 / Fax: 886-2-2298-4045
- No.81-1, Lane 210, Bade 2nd Rd., Lujhu Township, Taoyuan County 33841, Taiwan, R.O.C.
Tel: 886-3-324-0332 / Fax: 886-3-324-5235

The sites are constructed in conformance with the requirements of ANSI C63.7, ANSI C63.4 and CISPR Publication 22.

5.2. EQUIPMENT

Radiated emissions are measured with one or more of the following types of linearly polarized antennas: tuned dipole, biconical, log periodic, bi-log, and/or ridged waveguide, horn. Spectrum analyzers with pre-selectors and quasi-peak detectors are used to perform radiated measurements.





Conducted emissions are measured with Line Impedance Stabilization Networks and EMI Test Receivers.

Calibrated wideband preamplifiers, coaxial cables, and coaxial attenuators are also used for making measurements.

All receiving equipment conforms to CISPR Publication 16-1, "Radio Interference Measuring Apparatus and Measurement Methods."



5.3. TABLE OF ACCREDITATIONS AND LISTINGS

Country	Agency	Scope of Accreditation	Logo
USA	A2LA	CFR 47, FCC Part15/18, CISPR 22, EN 55022, ICES-003, AS/NZS CISPR 22, VCCI V-3, EN 55011, CISPR 11, IEC/EN 61000-4-2/3/4/5/6/8/11, EN 61000-6-1/2/3/4, EN 55024, CISPR 24, AS/NZS CISPR 24, AS/NZS 61000.6.2, EN 55014-1/-2, ETSI EN 300 386 v1.3.2/v1.3.3, IEC/EN 61000-3-2, AS/NZS 61000.3.2, IEC/EN 61000-3-3, AS/NZS 61000.3.3	 TESTING CERT #0824.01
USA	FCC MRA	3/10 meter Open Area Test Sites to perform FCC Part 15/18 measurements	
Japan	VCCI	3/10 meter Open Area Test Sites and conducted test sites to perform radiated/conducted measurements	VCCI R-2882/2541/2798/725/1868 C-402/747/912 T-1930/1646
Taiwan	TAF	EN 55014-1, CISPR 14, CNS 13781-1, EN 55013, CISPR 13, CNS 13439, EN 55011, CISPR 11, CNS 13803, PLMN09, IS2045-0, LP0002 FCC Part 27/90, Part 15B/C/D/E, RSS-192/193/210/310 ETSI EN 300 328/ 300 220-1/ 300 220-2/ 301 893/ 301 489-01/ 301 489-03/ 301 489-07 / 301 489-17/ 300 440-1/ 300 440-2 AS/NZS 4268, AS/NZS 4771 CISPR 22, EN 55022, CNS 13438, AS/NZS CISPR 22, VCCI, IEC/EN 61000-4-2/3/4/5/6/8/11, CNS 14676-2/3/4/5/6/8, CNS 14934-2/3, CNS 13783-1, CNS 13439, CNS 13803	
Taiwan	BSMI	CNS 13438, CNS 13783-1, CNS 13439, CNS 14115	SL2-IS-E-0014 / IN-E-0014 /A1-E-0014 /R1-E-0014 /R2-E-0014 /L1-E-0014
Canada	Industry Canada	RSS-Gen Issue 3	

Note: No part of this report may be used to claim or imply product endorsement by A2LA, TAF or other government agency.



6 SETUP OF EQUIPMENT UNDER TEST

6.1. SETUP CONFIGURATION OF EUT

See test photographs attached in Appendix 1 for the actual connections between EUT and support equipment.

6.2. SUPPORT EQUIPMENT

No.	Device Type	Brand	Model	Series No.	FCC ID	Data Cable	Power Cord
1.	N/A						

****No any support equipment during the test.**

Remark: *Grounding was established in accordance with the manufacturer's requirements and conditions for the intended use.*



7 FCC PART 15.247 REQUIREMENTS

Test Item	Test Result
6DB Bandwidth	PASS
Peak Power	PASS
Average Power	PASS
Band edges Measurement	PASS
Peak Power Spectral Density	PASS
Spurious Emissions	PASS
Powerline Conducted Emissions	PASS



7.1. 6dB bandwidth

LIMIT

According to §15.247(a)(2), systems using digital modulation techniques may operate in the 902 - 928 MHz, 2400 - 2483.5 MHz, and 5725 - 5850 MHz bands. The minimum 6 dB bandwidth shall be at least 500 kHz.

Test Configuration

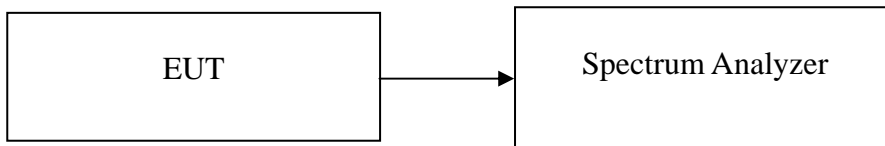

TEST PROCEDURE

The transmitter output is connected to the spectrum analyzer. Set the RBW=100kHz the emission bandwidth, VBW \geq 3 x RBW, Detector = Peak, Trace mode = max hold, Sweep = auto couple. Measure the maximum width of the emission that is constrained by the frequencies associated with the two amplitude points (upper and lower) that are attenuated by 6dB relative to the maximum level measured in the fundamental emission.

TEST RESULTS

No non-compliance noted

Test Data

Channel	Frequency (MHz)	6dB Bandwidth (kHz)	Limit (kHz)	Test Result
Low	2402	710	>500	PASS
Mid	2440	710		PASS
High	2480	710		PASS



Test Plot

6dB Bandwidth (CH Low)

Agilent

R T

Mkr1 710 kHz 0.48 dB

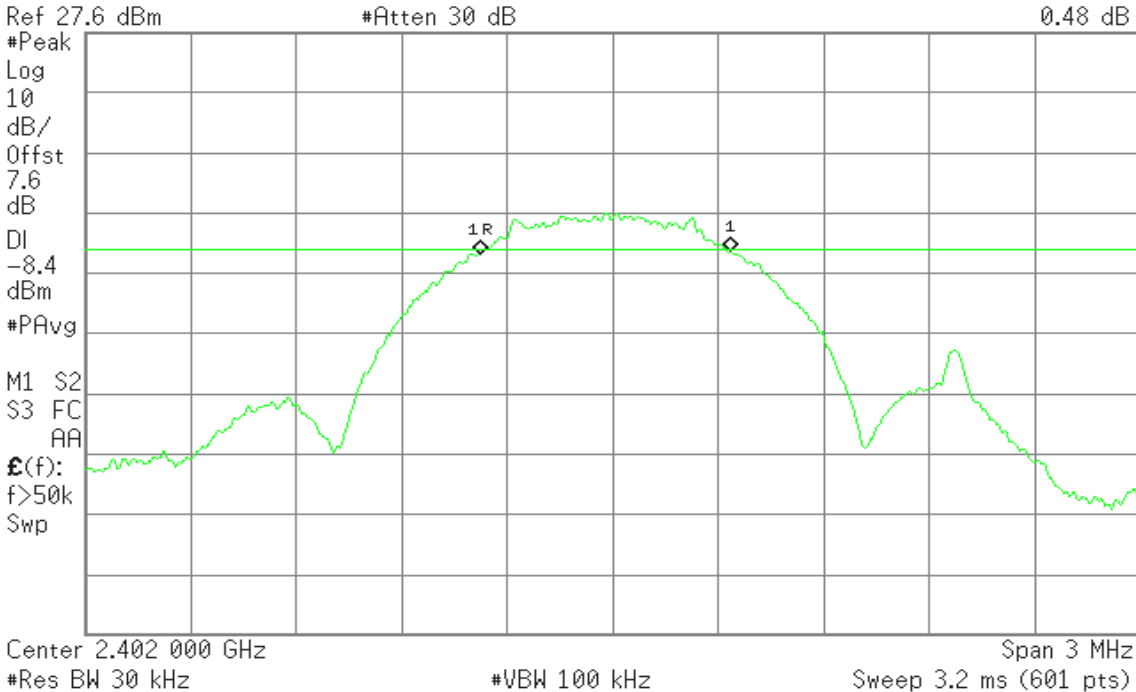

6dB Bandwidth (CH Mid)

Agilent

R T

Mkr1 710 kHz 0.33 dB

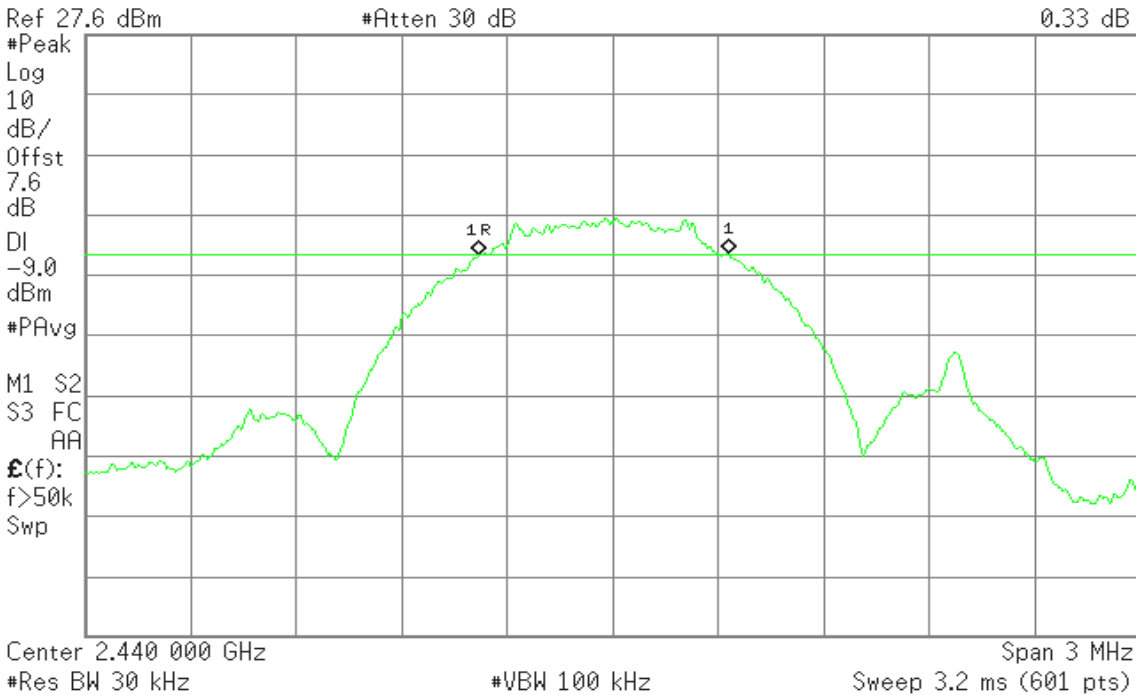



6dB Bandwidth (CH High)

Agilent

R T

Mkr1 710 kHz
0.81 dB

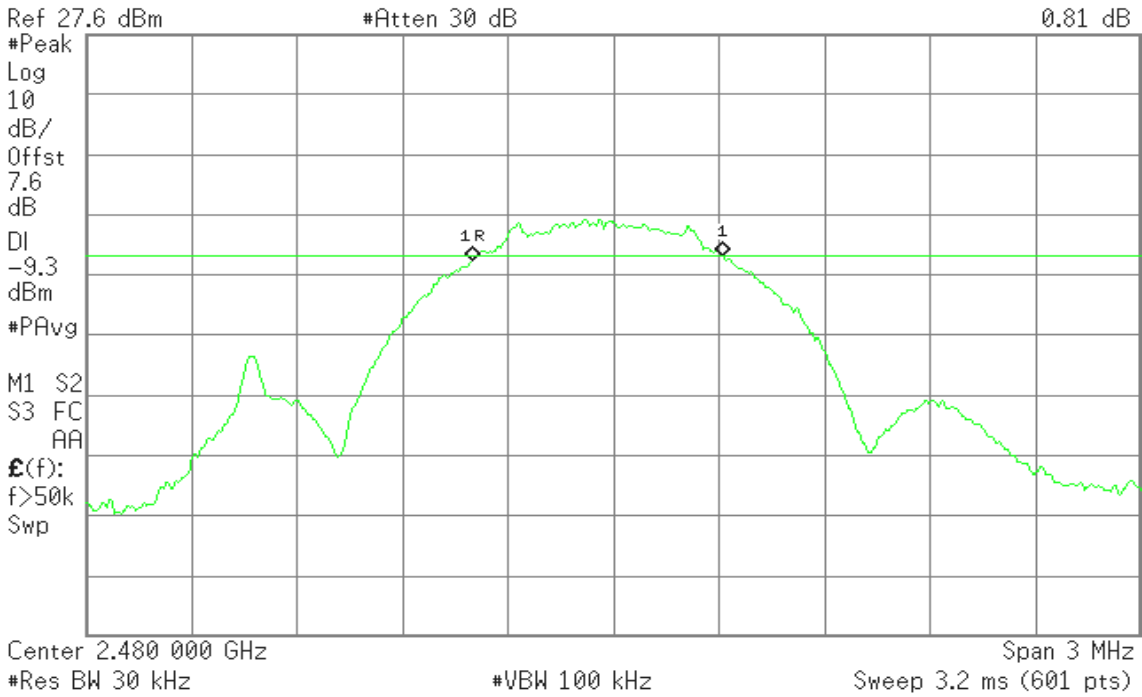



7.2. PEAK POWER

LIMIT

According to §15.247, the maximum peak output power of the intentional radiator shall not exceed the following:

1. According to §15.247(b)(3), for systems using digital modulation in the bands of 902-928 MHz, 2400-2483.5 MHz, and 5725-5850 MHz: 1 watt.
2. According to §15.247(b) (4), the conducted output power limit specified in paragraph (b) of this section is based on the use of antennas with directional gains that do not exceed 6 dBi. Except as shown in paragraph (c) of this section, if transmitting antennas of directional gain greater than 6 dBi are used, the conducted output power from the intentional radiator shall be reduced below the stated values in paragraphs (b)(1), (b)(2), and (b)(3) of this section, as appropriate, by the amount in dB that the directional gain of the antenna exceeds 6 dBi.

TEST CONFIGURATION

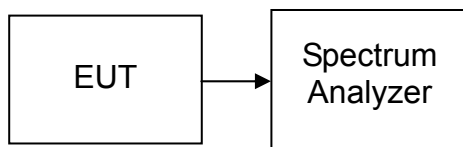

TEST PROCEDURE

Per KDB 558074 5.2.1.2/ or 5.2.2.1.

The transmitter output is connected to the spectrum analyzer. Set the RBW = 1MHz, VBW = 3MHz, Span=3MHz, Detector = Peak, Trace mode = max hold, Sweep = 100ms. Record the max reading.

Repeat the above procedure until the measurements for all frequencies are completed.

TEST RESULTS

No non-compliance noted



TEST DATA

Channel	Frequency (MHz)	Output Power (dBm)	Output Power (W)	Limit (W)	Test Result
Low	2402	1.75	0.0015	1	PASS
Mid	2440	1.24	0.0013		PASS
High	2480	0.67	0.0012		PASS



Test Plot

CH Low

Agilent

R T

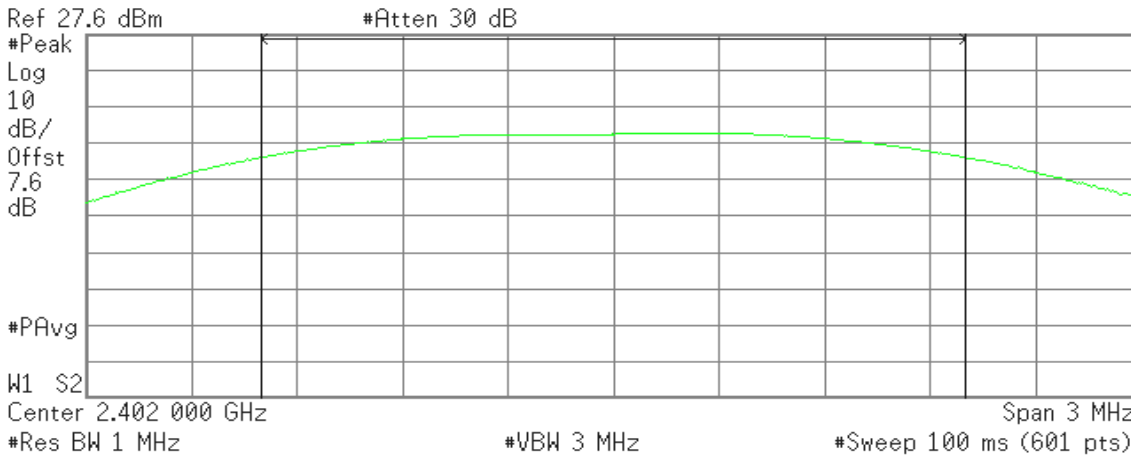

Channel Power

1.75 dBm /2.0000 MHz

Power Spectral Density

-61.26 dBm/Hz

CH Mid

Agilent

R T

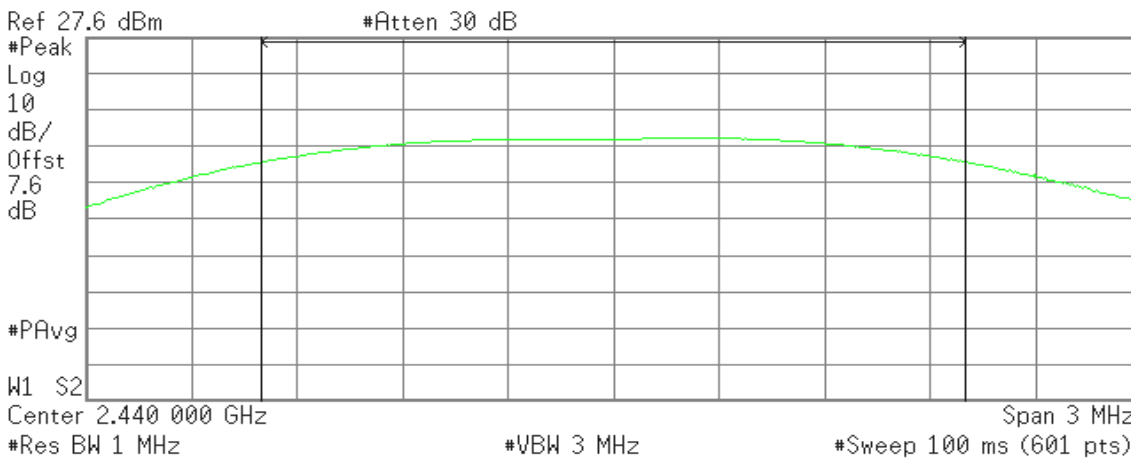

Channel Power

1.24 dBm /2.0000 MHz

Power Spectral Density

-61.77 dBm/Hz



CH High

Agilent

R T

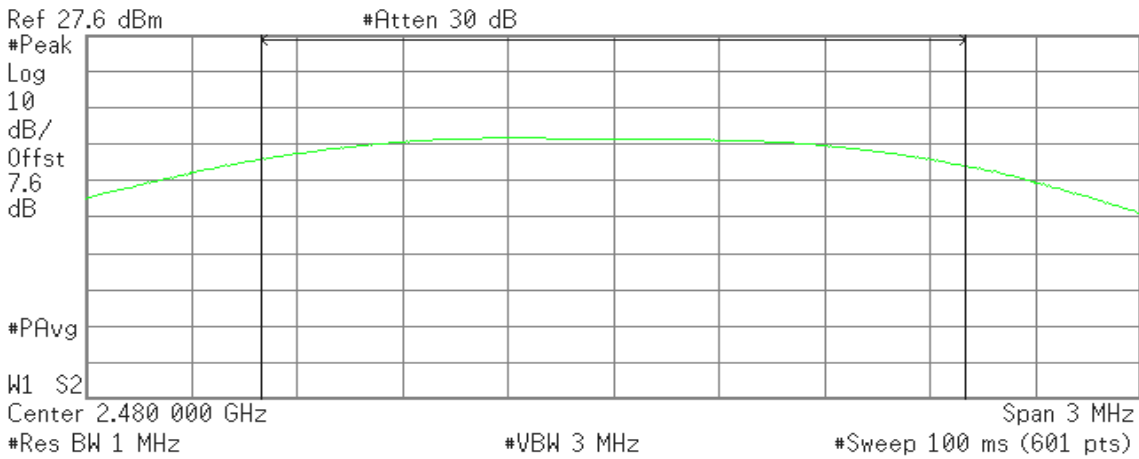

Channel Power

0.67 dBm /2.0000 MHz

Power Spectral Density

-62.34 dBm/Hz



7.3. AVERAGE POWER

LIMIT

None; for reporting purposes only.

TEST CONFIGURATION

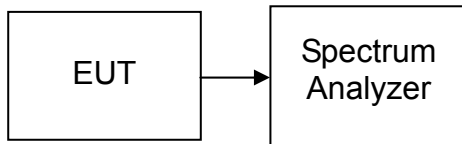

TEST PROCEDURE

Per KDB 558074 5.2.1.2/ or 5.2.2.1.

The transmitter output is connected to the spectrum analyzer. Set the RBW = 1MHz, VBW = 3MHz, Span=3MHz, Detector = sample, Trace mode = max hold, Sweep = 100ms. Record the max reading.

Repeat the above procedure until the measurements for all frequencies are completed.

TEST RESULTS

No non-compliance noted

TEST DATA

Channel	Frequency (MHz)	Output Power (dBm)	Output Power (W)
Low	2402	-0.08	0.0010
Mid	2440	-0.62	0.0009
High	2480	-1.1	0.0008



Test Plot

CH Low

* Agilent

R T

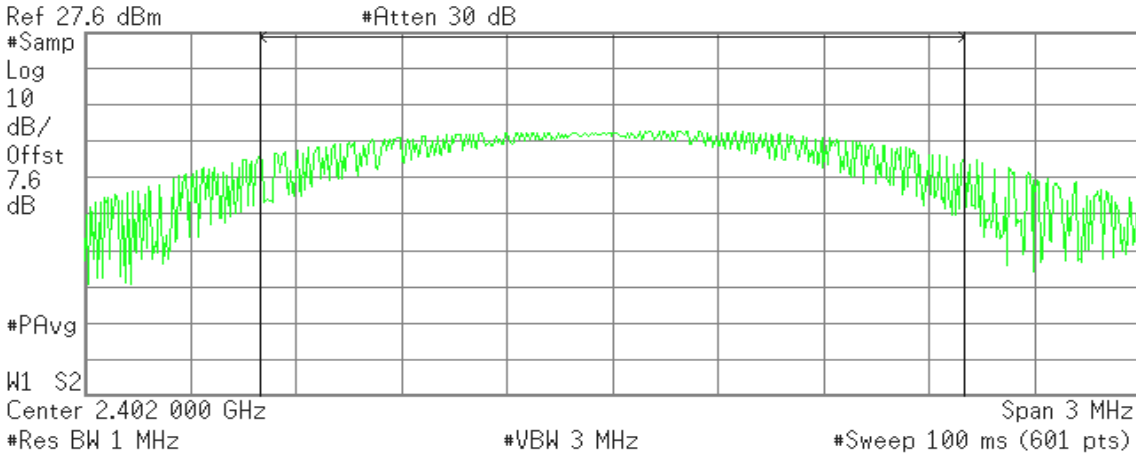

Channel Power

-0.08 dBm /2.0000 MHz

Power Spectral Density

-63.09 dBm/Hz

CH Mid

* Agilent

R T

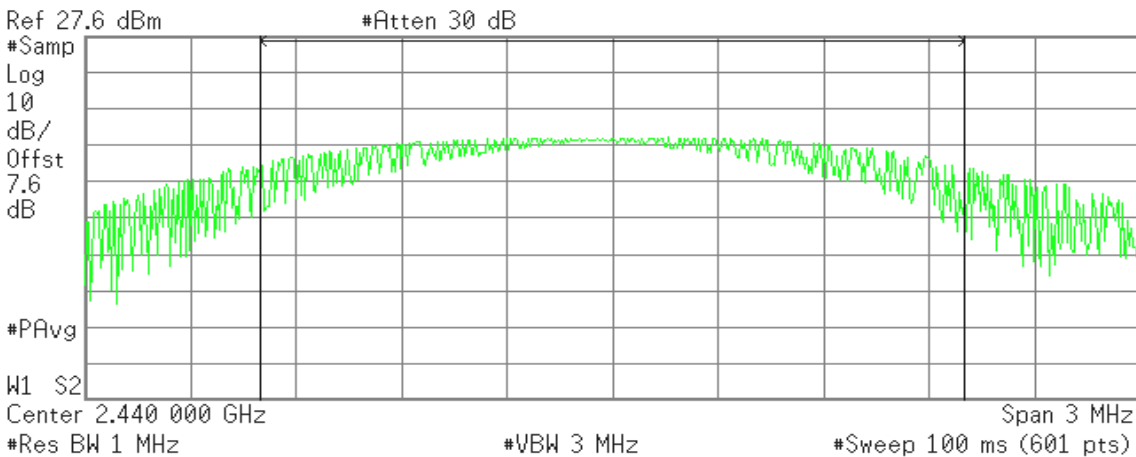

Channel Power

-0.62 dBm /2.0000 MHz

Power Spectral Density

-63.63 dBm/Hz



CH High

Agilent

R T

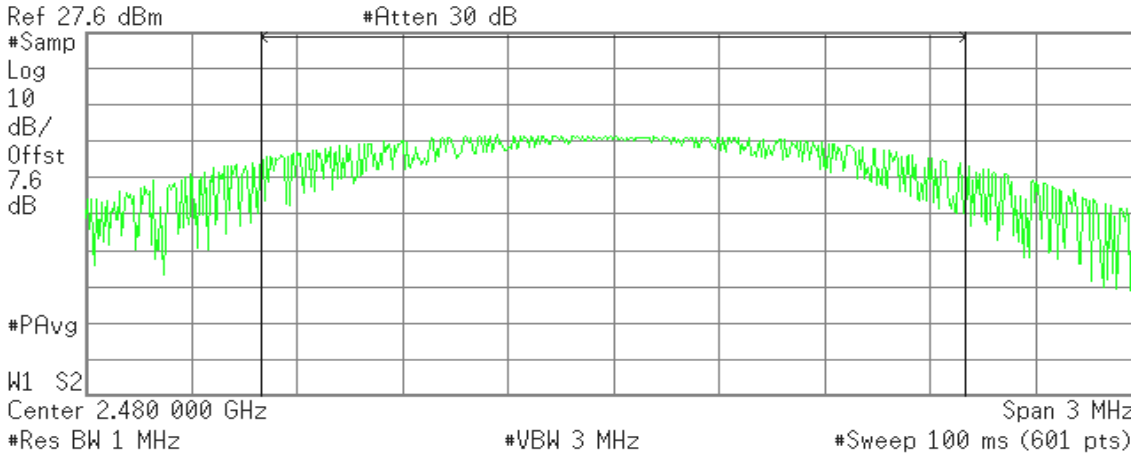

Channel Power

-1.10 dBm /2.0000 MHz

Power Spectral Density

-64.11 dBm/Hz



7.4. BAND EDGES MEASUREMENT

LIMIT

According to §15.247(d), in any 100 kHz bandwidth outside the frequency bands in which the spread spectrum intentional radiator is operating, the radio frequency power that is produced by the intentional radiator shall be at least 20 dB below that in the 100 kHz bandwidth within the band that contains the highest level of the desired power, based on either an RF conducted or a radiated measurement, provided the transmitter demonstrates compliance with the peak conducted power limits. In addition, radiated emissions which fall in the restricted bands, as defined in §15.205(a), must also comply with the radiated emission limits specified in 15.209(a) (see Section 15.205(c)).

TEST CONFIGURATION

For Radiated

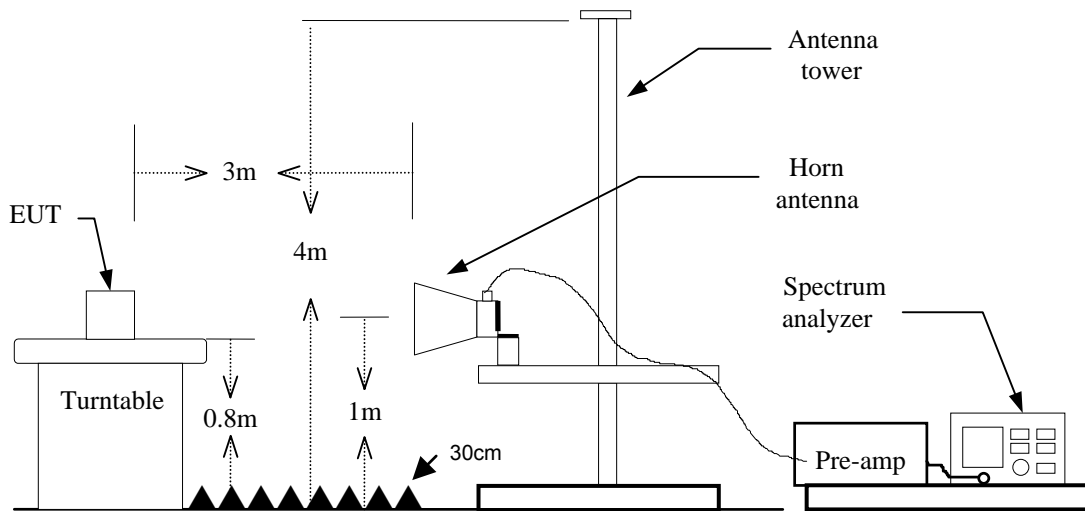

For Conducted

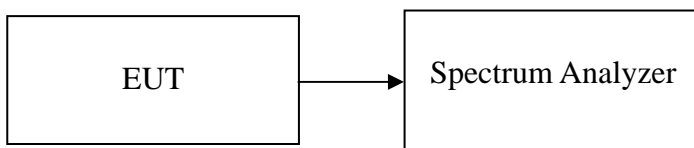



TEST PROCEDURE

For Radiated

1. The EUT is placed on a turntable, which is 0.8m above the ground plane.
2. The turntable shall be rotated for 360 degrees to determine the position of maximum emission level.
3. EUT is set 3m away from the receiving antenna, which is varied from 1m to 4m to find out the highest emission.
4. Set the spectrum analyzer in the following setting in order to capture the lower and upper band-edges of the emission:
 - (a) PEAK: RBW=1MHz / VBW=1MHz / Sweep=AUTO
 - (b) AVERAGE: RBW=1MHz / VBW= 10Hz / Sweep=AUTO
5. Repeat the procedures until all the PEAK and AVERAGE versus POLARIZATION are measured.

For Conducted

Conducted RF measurements of the transmitter output were made to confirm that the EUT antenna port conducted emissions meet the specified limit and to identify any spurious signals that require further investigation or measurements on the radiated emissions site.

The transmitter output is connected to the spectrum analyzer. The resolution bandwidth is set to 100 kHz. The video bandwidth is set to 100 kHz.

TEST RESULTS

Refer to attach spectrum analyzer data chart.



Band Edges (CH Low)

Detector mode: Peak

Polarity: Vertical

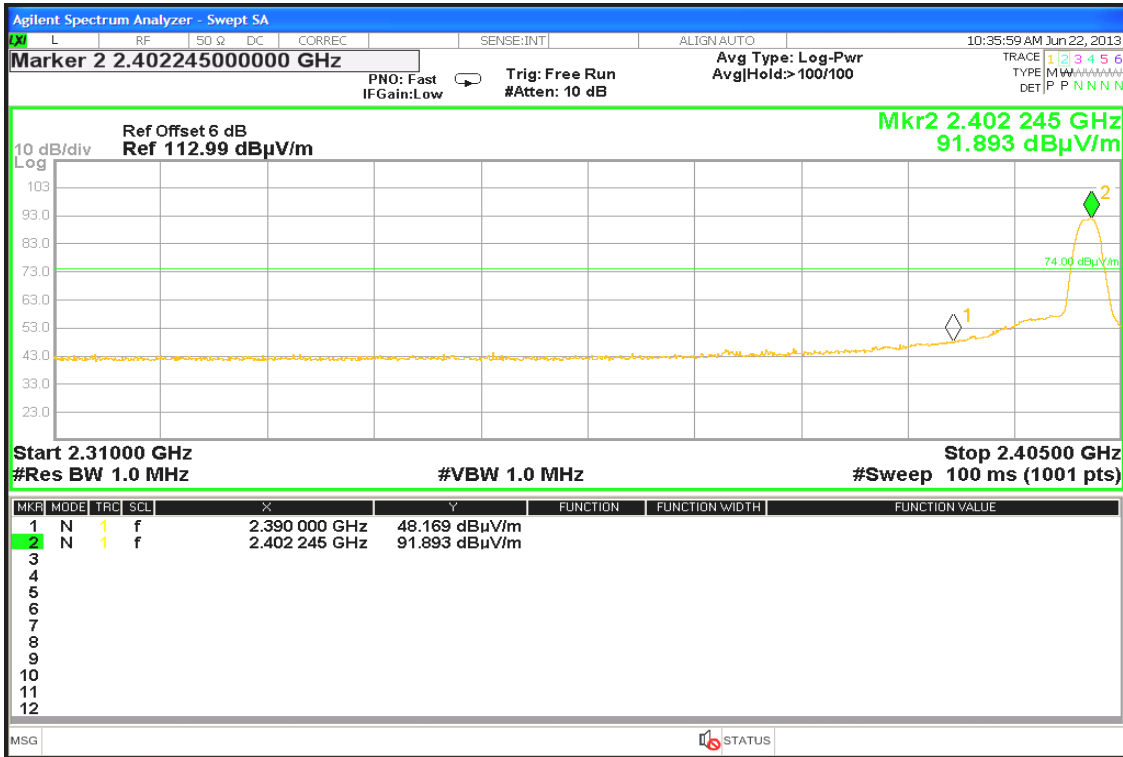

Detector mode: Average

Polarity: Vertical

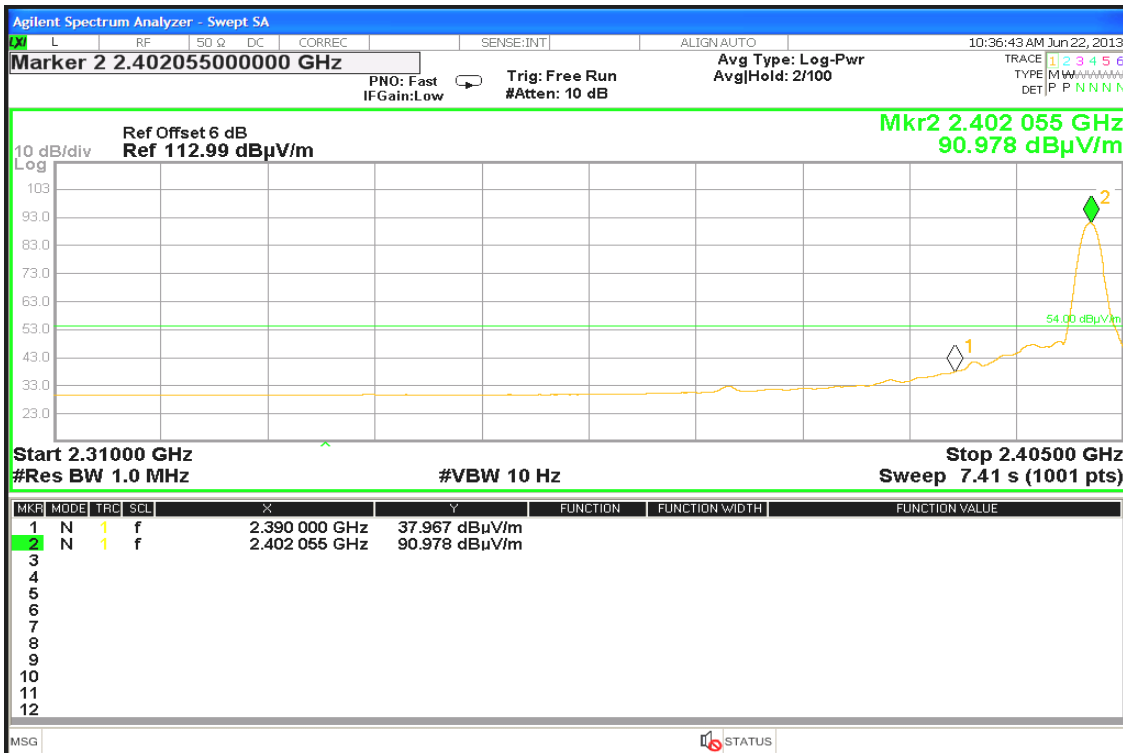



Detector mode: Peak

Polarity: Horizontal

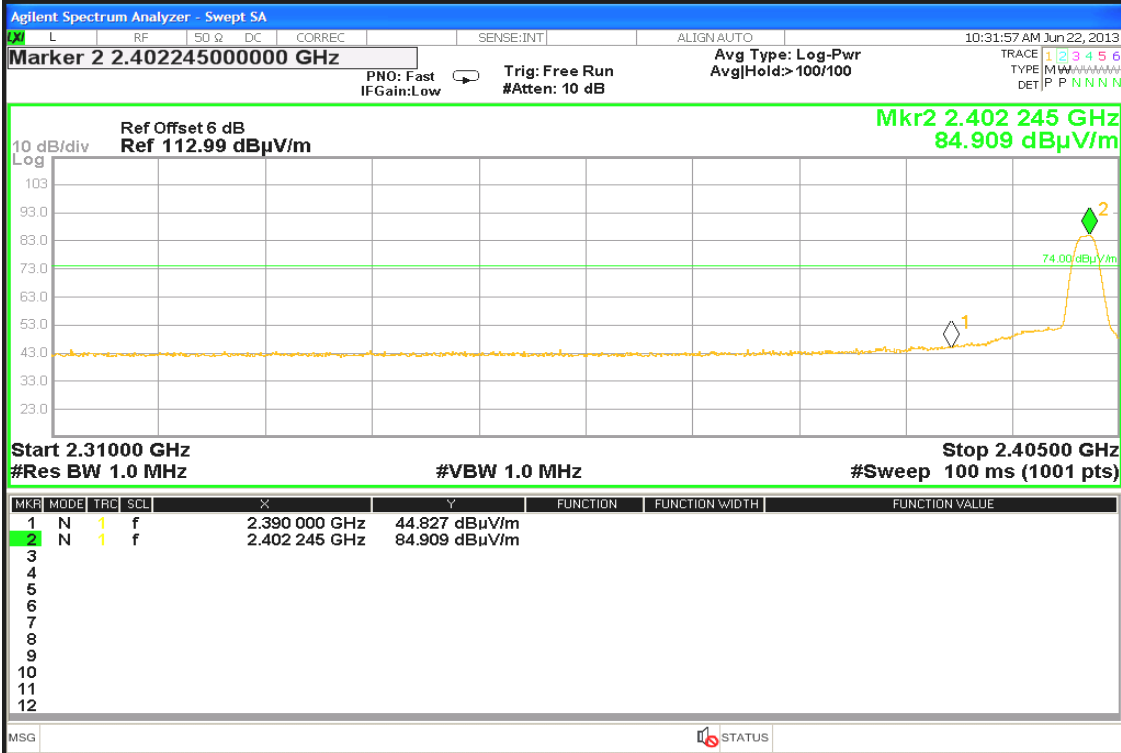

Detector mode: Average

Polarity: Horizontal

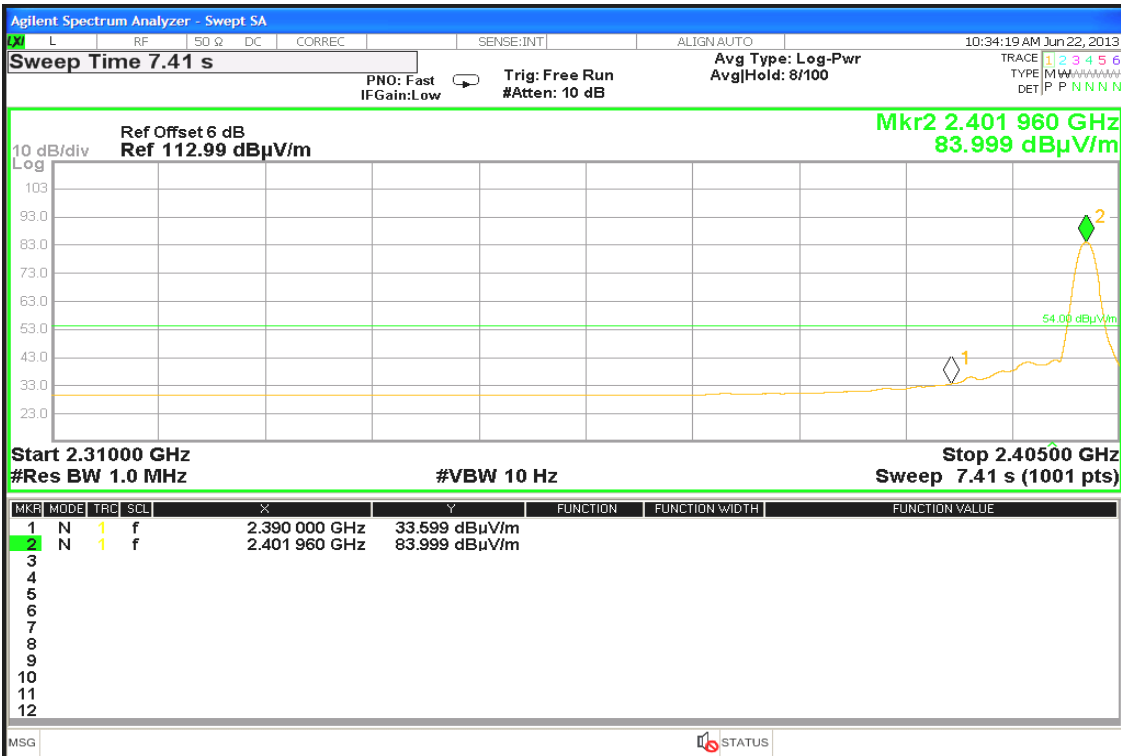



Band Edges (CH High)

Detector mode: Peak

Polarity: Vertical

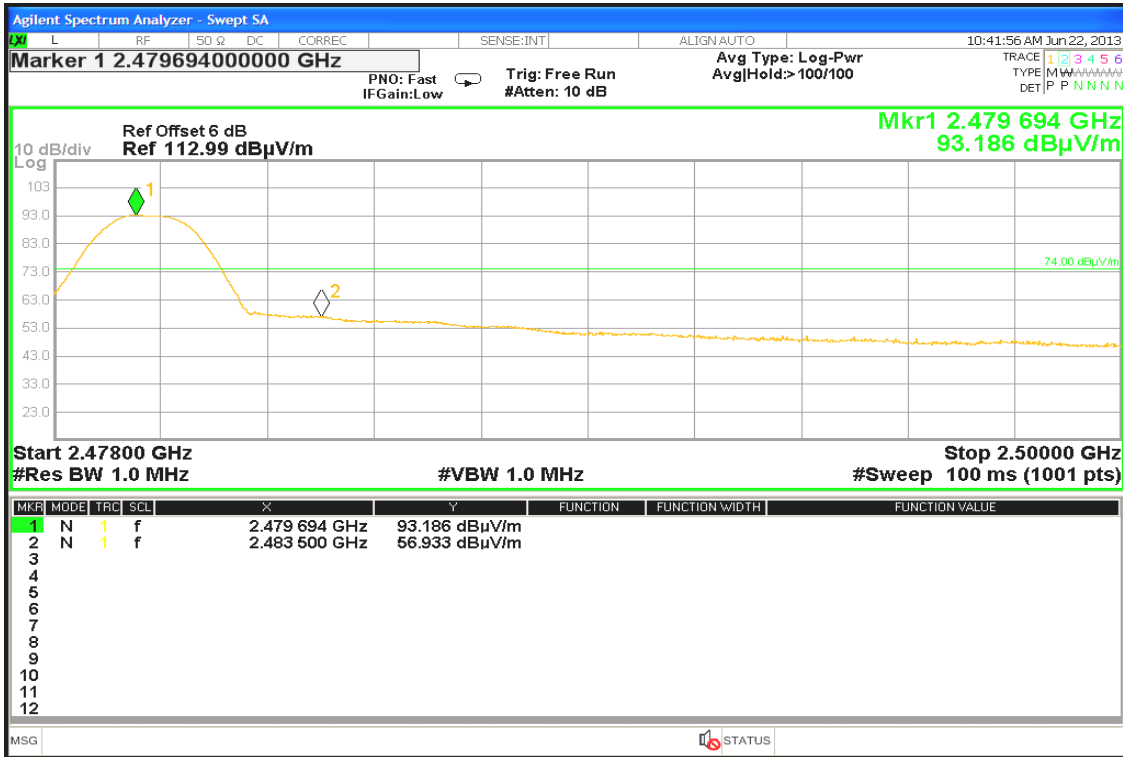

Detector mode: Average

Polarity: Vertical

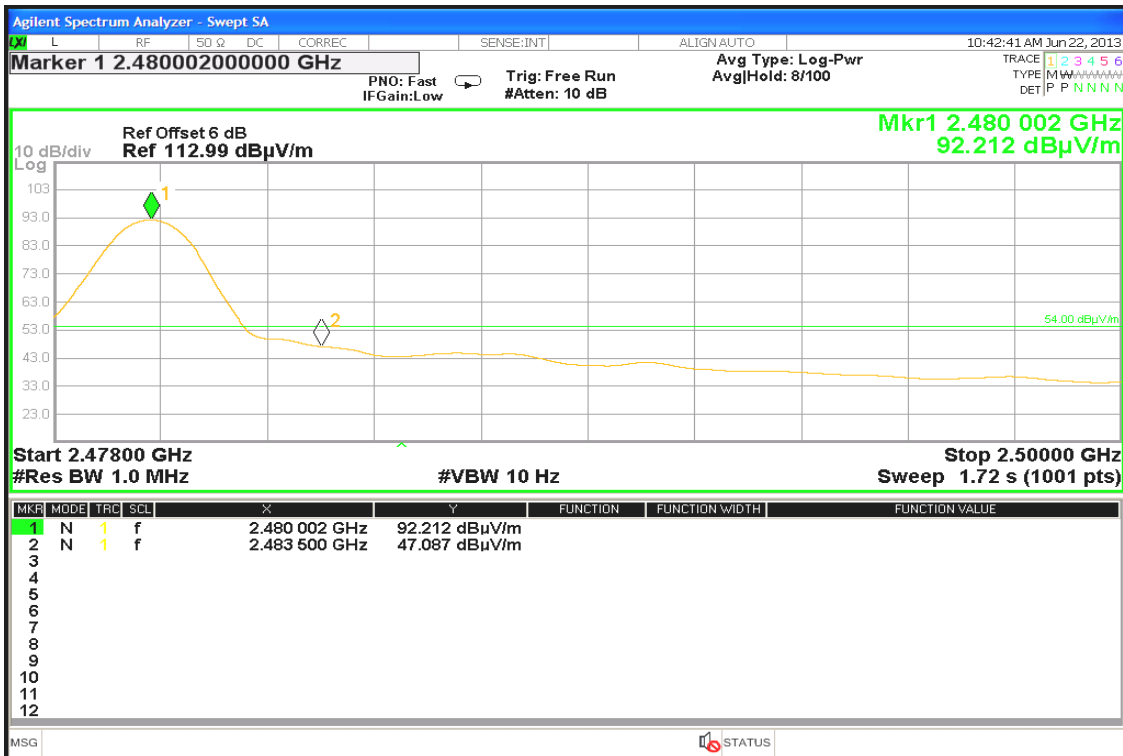



Detector mode: Peak

Polarity: Horizontal

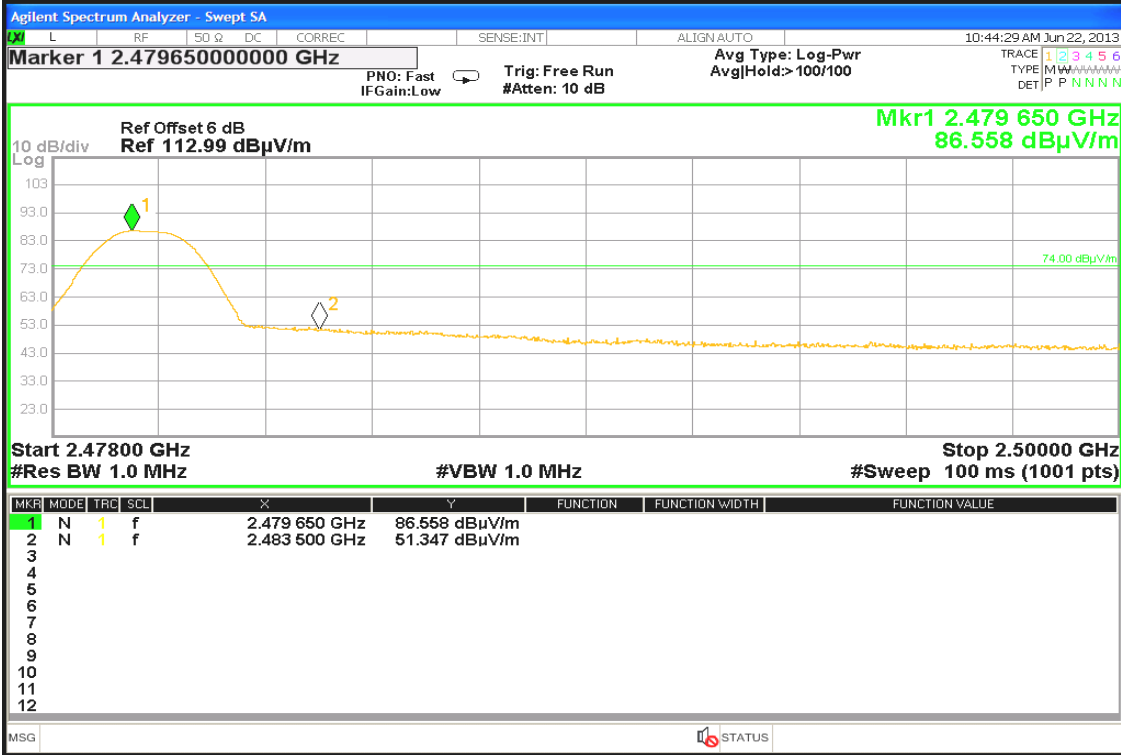

Detector mode: Average

Polarity: Horizontal

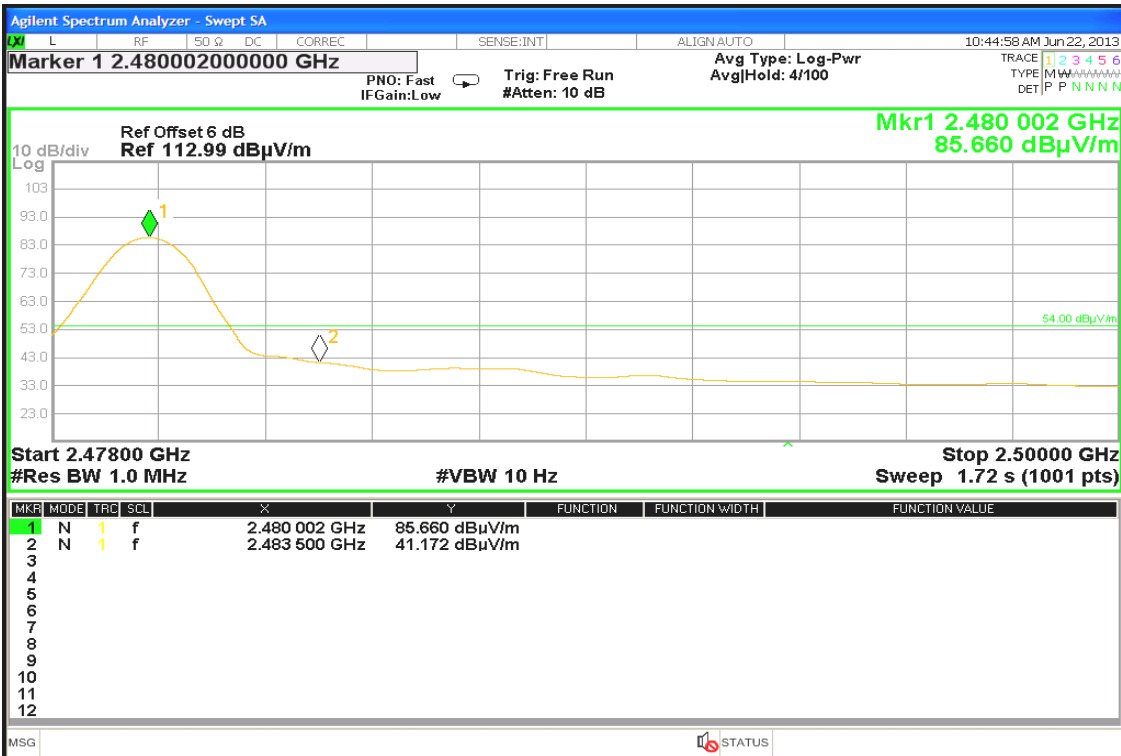



Conducted band-edge

CH Low

Agilent

R T

Mkr2 2.402 225 GHz
-0.06 dBm

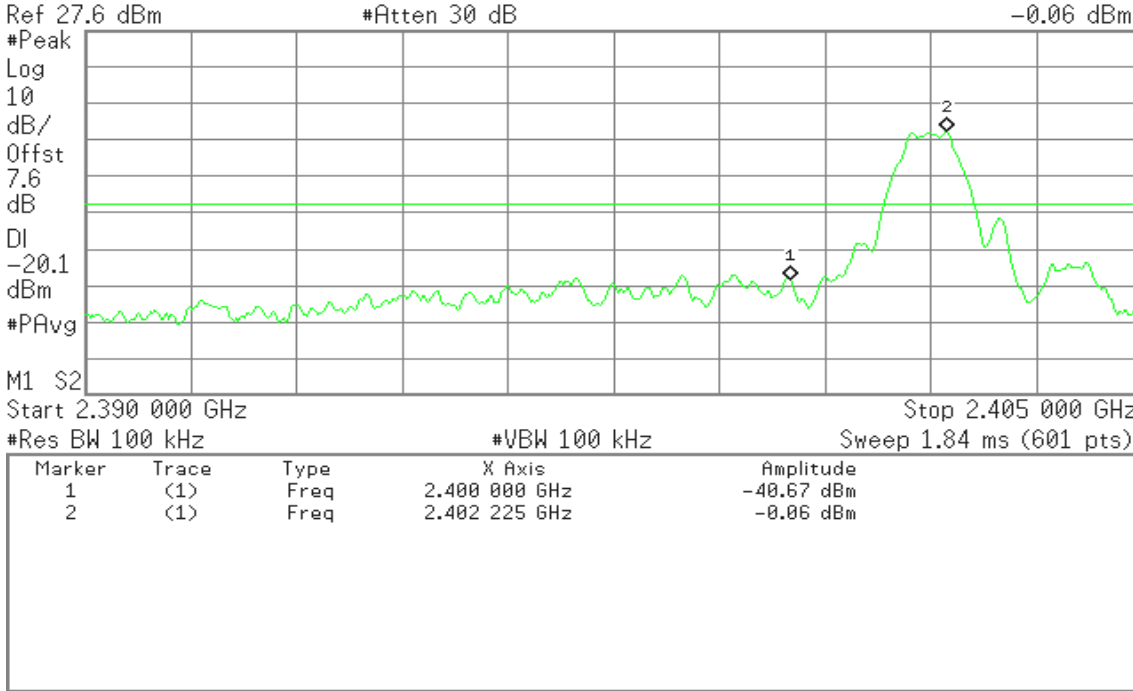

CH High

Agilent

R T

Mkr1 2.479 72 GHz
-1.08 dBm

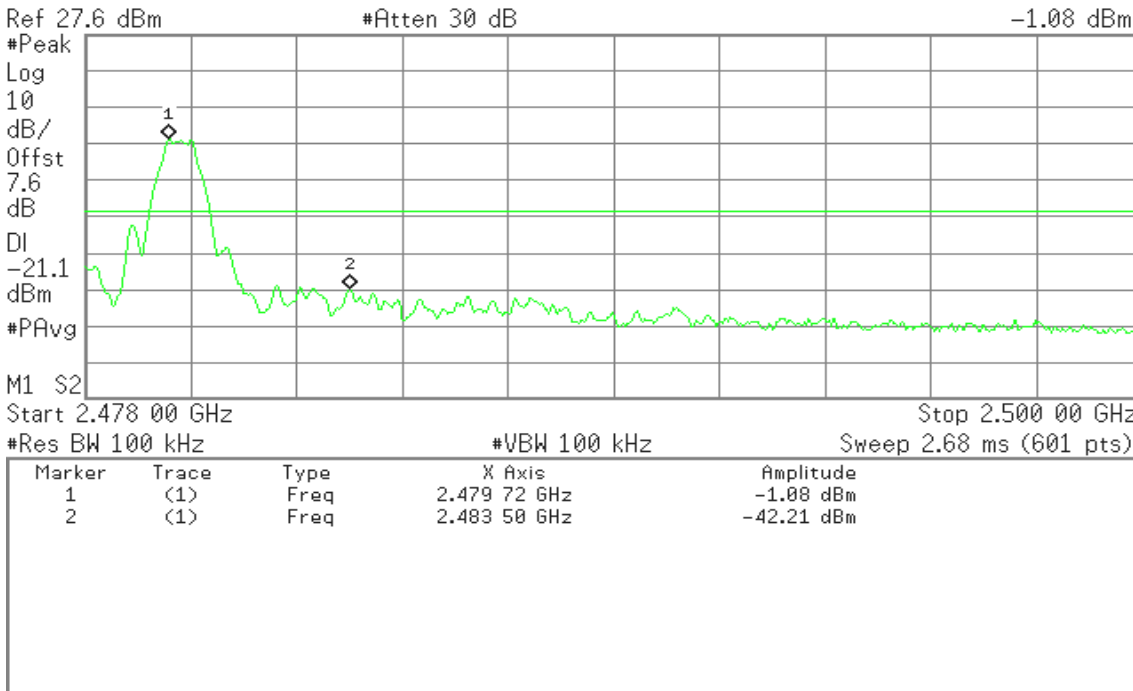



7.5. PEAK POWER SPECTRAL DENSITY

LIMIT

1. According to §15.247(e), for digitally modulated systems, the power spectral density conducted from the intentional radiator to the antenna shall not be greater than 8 dBm in any 3 kHz band during any time interval of continuous transmission.
2. According to §15.247(f), the digital modulation operation of the hybrid system, with the frequency hopping turned off, shall comply with the power density requirements of paragraph (d) of this section.

Test Configuration

TEST PROCEDURE

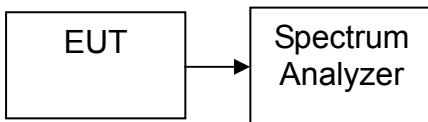

Per KDB 558074 D01 DTS Meas Guidance v02

This procedure must be used if maximum peak conducted output power was used to demonstrate compliance to the fundamental output power limit, and is optional if the maximum (average) conducted output power was used to demonstrate compliance.

1. Set analyzer center frequency to DTS channel center frequency.
2. Set the span to 1.5 times the DTS channel bandwidth.
3. Set the RBW \geq 3 kHz.
4. Set the VBW \geq 3 x RBW.
5. Detector = peak.
6. Sweep time = auto couple.
7. Trace mode = max hold.
8. Allow trace to fully stabilize.

Use the peak marker function to determine the maximum amplitude level.

If measured value exceeds limit, reduce RBW (no less than 3 kHz) and repeat



TEST RESULTS

No non-compliance noted

Test Data

Channel	Frequency (MHz)	PPSD (dBm)	Limit (dBm)	Result
Low	2402	-12.10	8.00	PASS
Mid	2440	-12.12		PASS
High	2480	-12.99		PASS



Test Plot

PPSD (CH Low)

Agilent

R T

Mkr1 2.402 020 3 GHz
-12.10 dBm

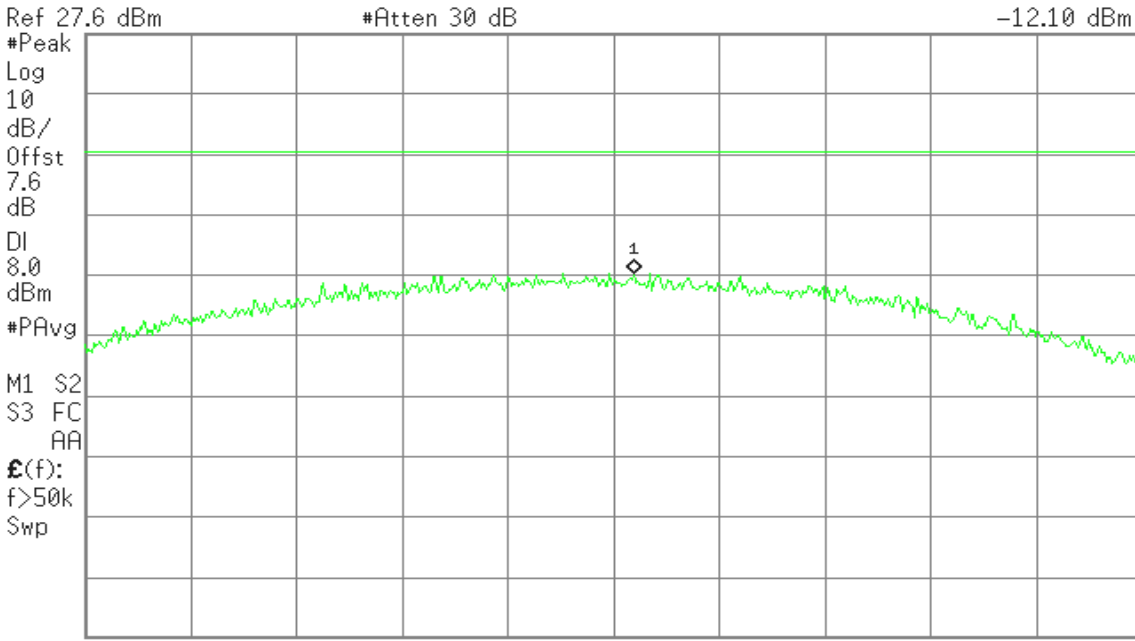

Center 2.402 000 0 GHz Span 1 MHz
#Res BW 3 kHz #VBW 10 kHz Sweep 105.4 ms (601 pts)

PPSD (CH Mid)

Agilent

R T

Mkr1 2.439 989 9 GHz
-12.12 dBm

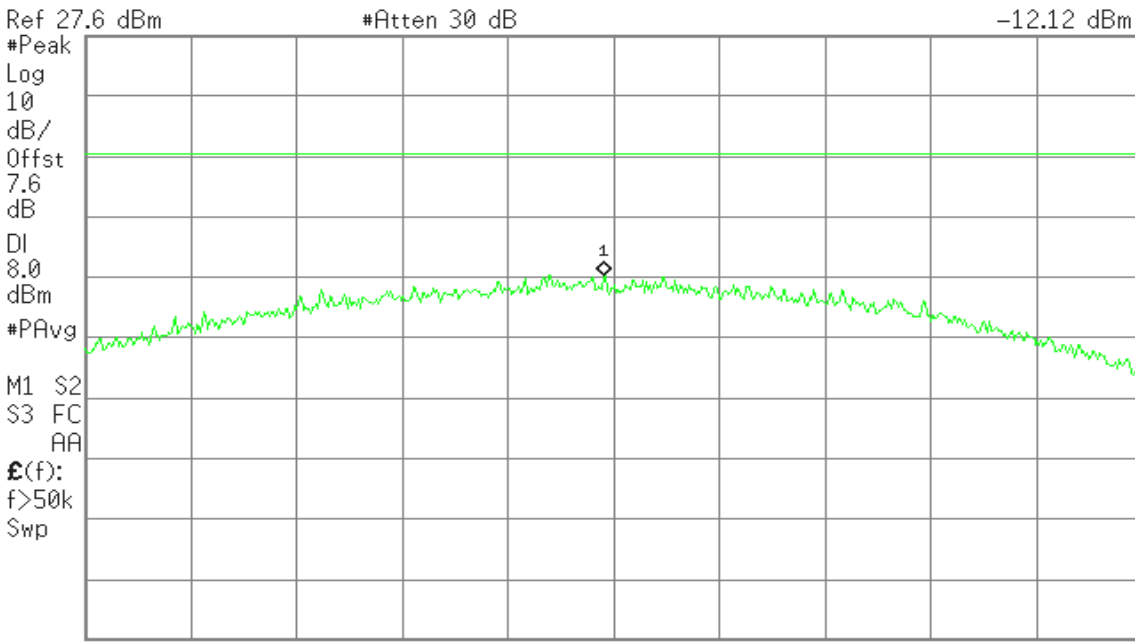

Center 2.440 000 0 GHz Span 1 MHz
#Res BW 3 kHz #VBW 10 kHz Sweep 105.4 ms (601 pts)



PPSD (CH High)

Agilent

R T

Mkr1 2.479 950 9 GHz
-12.99 dBm

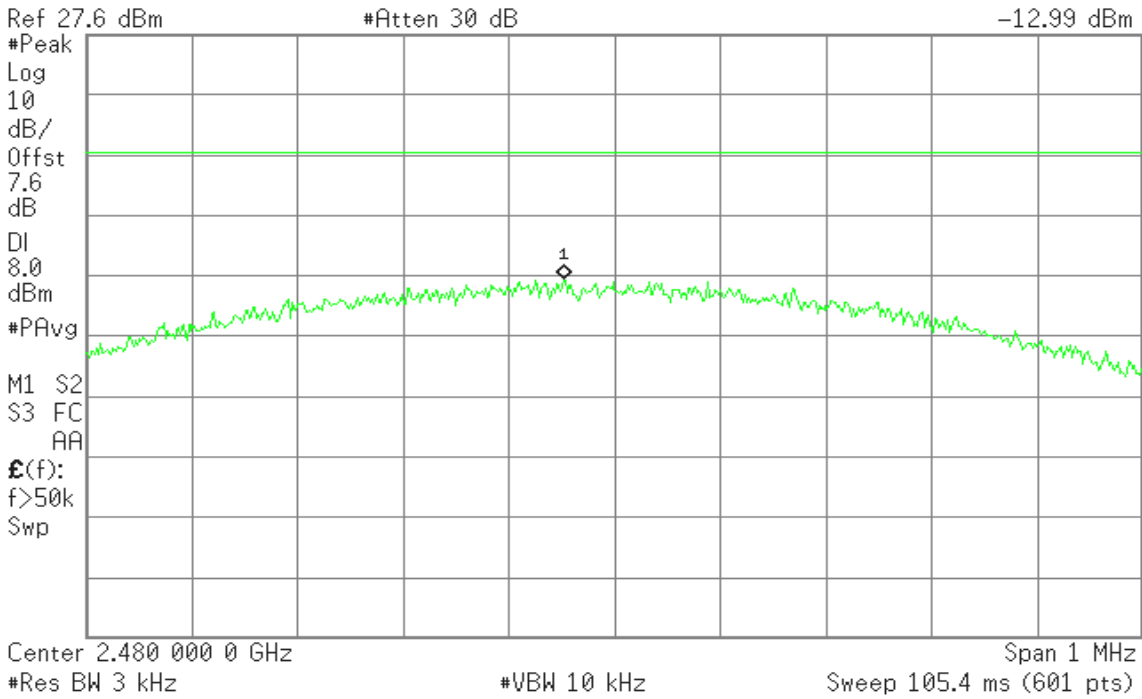



7.6. SPURIOUS EMISSIONS

7.6.1. Conducted Measurement

LIMIT

In any 100 kHz bandwidth outside the frequency band in which the spread spectrum or digitally modulated intentional radiator is operating, the radio frequency power that is produced by the intentional radiator shall be at least 20 dB below that in the 100 kHz bandwidth within the band that contains the highest level of the desired power, based on either an RF conducted or a radiated measurement. Attenuation below the general limits specified in Section 15.209(a) is not required. In addition, radiated emissions which fall in the restricted bands, as defined in Section 15.205(a), must also comply with the radiated emission limits specified in Section 15.209(a) (see Section 15.205(c)).

TEST CONFIGURATION

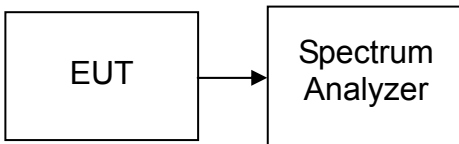

TEST PROCEDURE

Conducted RF measurements of the transmitter output were made to confirm that the EUT antenna port conducted emissions meet the specified limit and to identify any spurious signals that require further investigation or measurements on the radiated emissions site.

The transmitter output is connected to the spectrum analyzer. The resolution bandwidth is set to 100 kHz. The video bandwidth is set to 100 kHz.

Measurements are made over the 30MHz to 26GHz range with the transmitter set to the lowest, middle, and highest channels.

TEST RESULTS

No non-compliance noted

TEST DATA

Refer to attach spectrum analyzer data chart.



Test Plot

Spurious Emissions

CH Low

Agilent

R T

Mkr1 2.41 GHz
-1.15 dBm

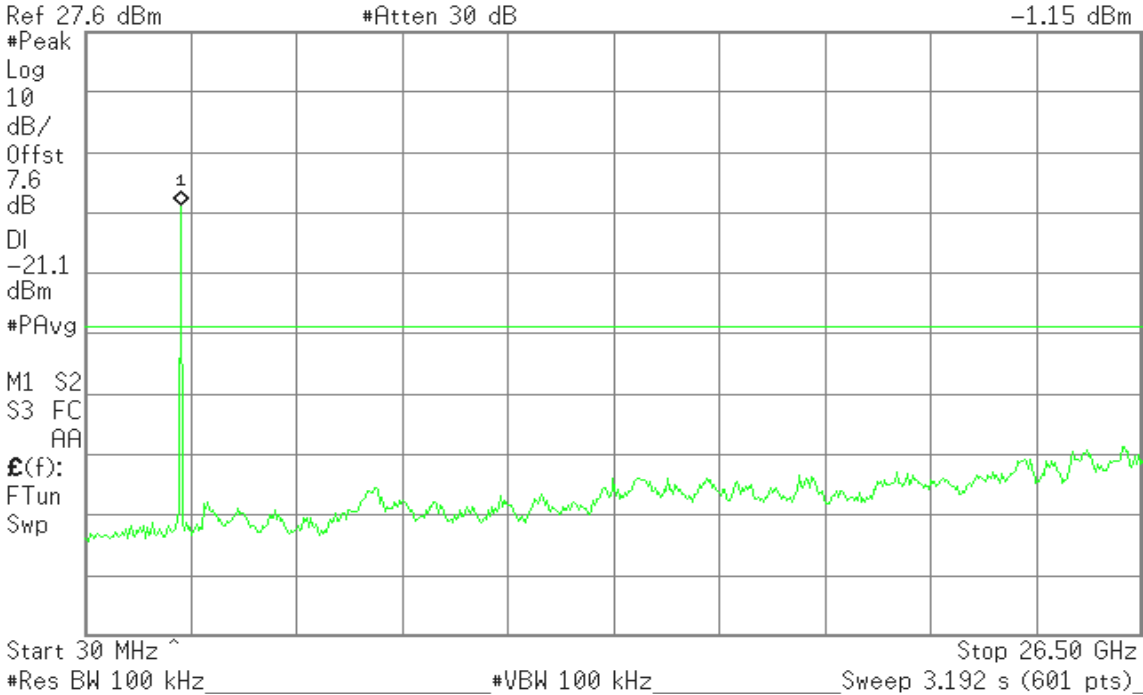

CH Mid

Agilent

R T

Mkr1 2.46 GHz
-2.43 dBm

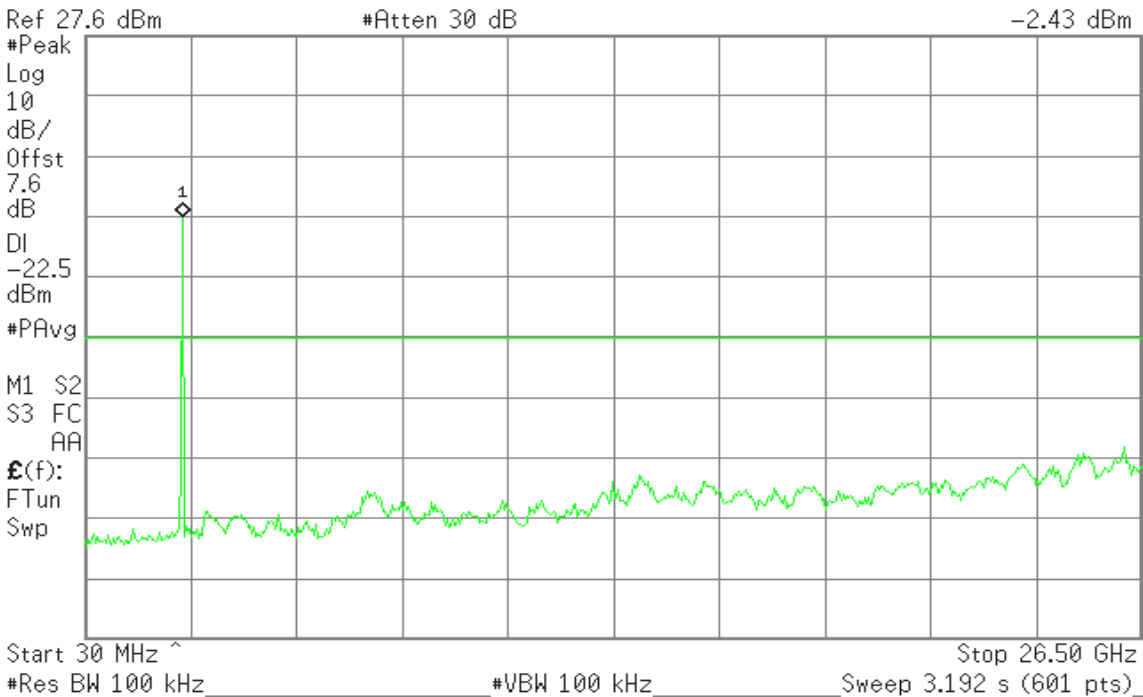



Compliance Certification Services Inc.

Report No.: T130605L06-RP1 FCC ID: B9Q-MYMET30019 Date of Issue: July 2, 2013

CH High

Agilent

R T

Mkr1 2.50 GHz
-3.66 dBm

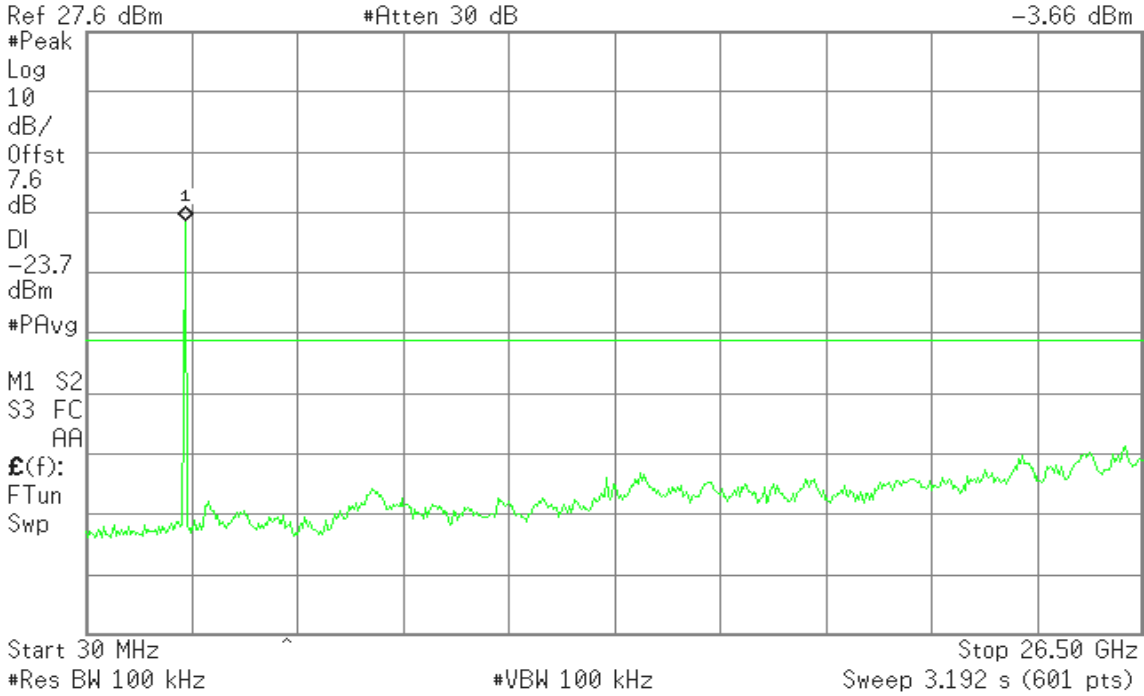



7.6.2. RADIATED EMISSIONS

LIMIT

1. According to §15.209(a), except as provided elsewhere in this Subpart, the emissions from an intentional radiator shall not exceed the field strength levels specified in the following table:

Frequency (MHz)	Field Strength (µV/m)	Measurement Distance (m)
0.009-0.490	2400/F(kHz)	300
0.490-1.705	24000/F(kHz)	30
1.705-30.0	30	30
30-88	100*	3
88-216	150*	3
216-960	200*	3
Above 960	500	3

Remark: Except as provided in paragraph (g), fundamental emissions from intentional radiators operating under this section shall not be located in the frequency bands 54–72 MHz, 76–88 MHz, 174–216 MHz or 470–806 MHz. However, operation within these frequency bands is permitted under other sections of this part, e.g., §§ 15.231 and 15.241.

2. In the emission table above, the tighter limit applies at the band edges.

Frequency (Hz)	Field Strength (µV/m at 3-meter)	Field Strength (dBµV/m at 3-meter)
30-88	100	40
88-216	150	43.5
216-960	200	46
Above 960	500	54



TEST CONFIGURATION

9kHz ~ 30MHz

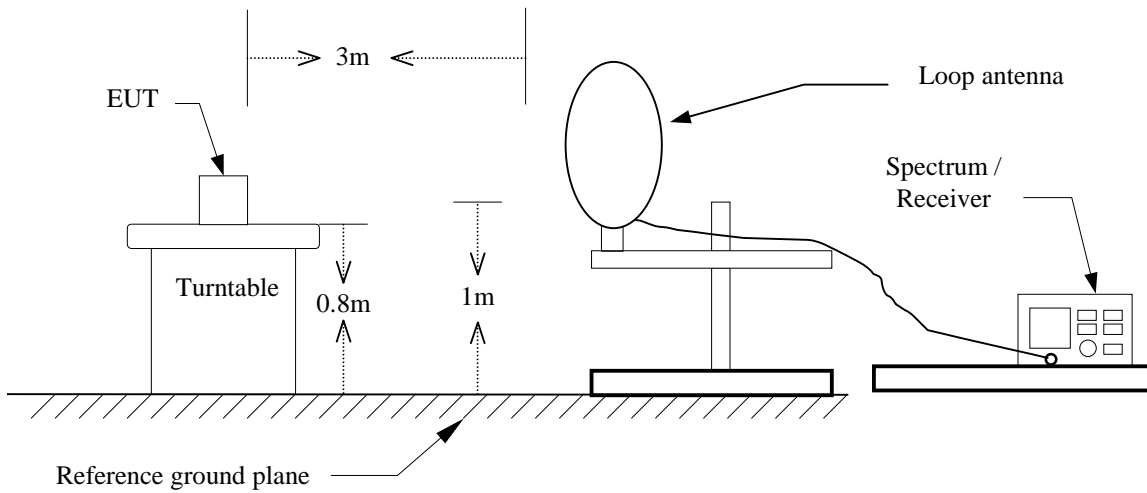

30MHz ~ 1GHz

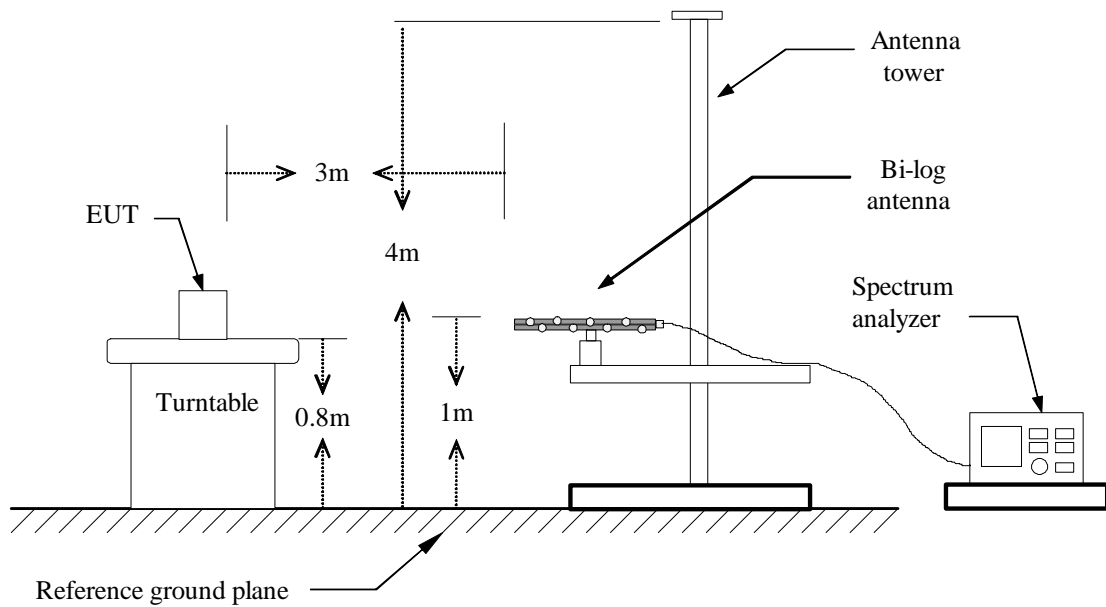



Above 1 GHz

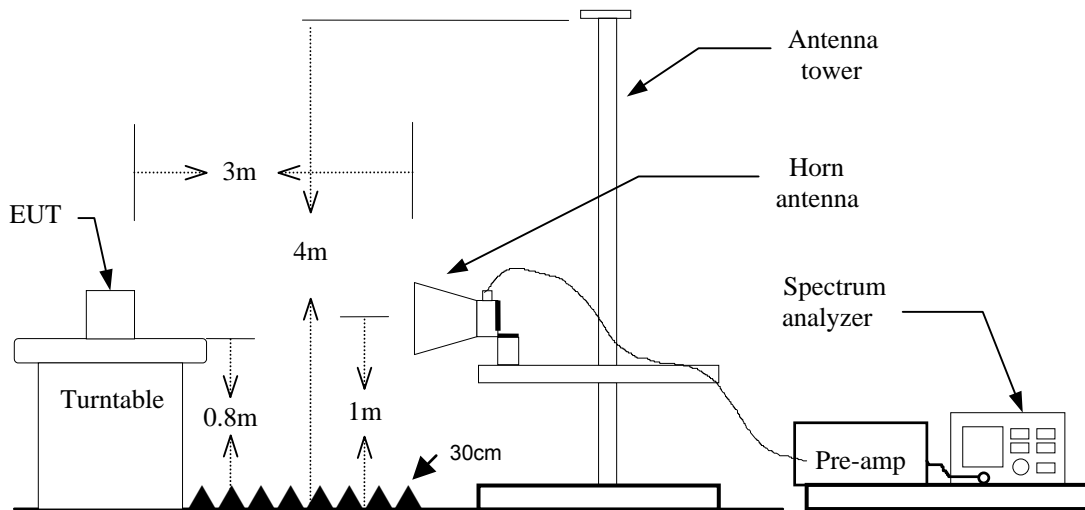

TEST PROCEDURE

1. The EUT is placed on a turntable, which is 0.8m above ground plane.
2. The turntable shall be rotated for 360 degrees to determine the position of maximum emission level.
3. EUT is set 3m away from the receiving antenna, which is varied from 1m to 4m to find out the highest emissions.
4. Maximum procedure was performed on the six highest emissions to ensure EUT compliance.
5. And also, each emission was to be maximized by changing the polarization of receiving antenna both horizontal and vertical.
6. Set the spectrum analyzer in the following setting as:

Below 30MHz

RBW=10kHz / VBW=30kHz / Sweep=AUTO

30 ~ 1000MHz:

RBW=100kHz / VBW=300KHz / Sweep=AUTO

Above 1GHz:

- a) PEAK: RBW=VBW=1MHz / Sweep=AUTO
- b) AVERAGE: RBW=1MHz / VBW=10Hz / Sweep=AUTO

7. Repeat above procedures until the measurements for all frequencies are complete.

TEST RESULTS

No non-compliance noted



TEST DATA

Below 1 GHz

Operation Mode: Normal Link

Test Date: 2013/6/20

Temperature: 26°C

Tested by: Louis Shen

Humidity: 56 % RH

Polarity: Ver. / Hor.

Frequency (MHz)	Reading (dBuV)	Correction Factor (dB/m)	Result (dBuV/m)	Limit (dBuV/m)	Margin (dB)	Ant. Pol. (H/V)	Remark
99.4400	34.50	2.01	36.51	43.50	-6.99	V	QP
134.7599	27.58	0.26	27.84	43.50	-15.66	V	QP
198.8800	48.10	-15.01	33.09	43.50	-10.41	V	QP
400.0100	31.60	-10.74	20.86	46.00	-25.14	V	QP
599.3899	35.10	-8.04	27.06	46.00	-18.94	V	QP
664.9100	25.20	-7.78	17.42	46.00	-28.58	V	QP
50.3699	32.50	1.53	34.03	40.00	-5.97	H	QP
161.8700	21.80	2.53	24.33	43.50	-19.17	H	QP
198.9100	41.80	-10.63	31.17	43.50	-12.33	H	QP
399.0900	37.00	-12.06	24.94	46.00	-21.06	H	QP
499.4200	28.20	-9.36	18.84	46.00	-27.16	H	QP
599.5700	31.80	-7.65	24.15	46.00	-21.85	H	QP

Remark:

1. No emission found between lowest internal used / generated frequency to 30 MHz. (9kHz ~ 30MHz)
2. Measuring frequencies from 30 MHz to the 1GHz.
3. Radiated emissions measured in frequency range from 30 MHz to 1000MHz were made with an instrument using Peak detector mode.
4. Data of measurement within this frequency range shown " --- " in the table above means the reading of emissions are attenuated more than 20dB below the permissible limits or the field strength is too small to be measured.
5. The IF bandwidth of SPA between 30MHz to 1GHz was 100kHz.



Above 1 GHz

Operation Mode:	TX / CH Low	Test Date:	2013/6/21
Temperature:	26°C	Tested by:	Francis Lee
Humidity:	56% RH	Polarity:	Ver. / Hor.

Freq. (MHz)	Reading (dBuV)	Correct Factor (dB/m)	Result (dBuV/m)	Limit (dBuV/m)	Margin (dB)	Ant. Pol H/V	Remark
1458.000	50.94	-5.84	45.10	74.00	-28.90	V	peak
1974.000	48.97	-1.71	47.26	74.00	-26.74	V	peak
2702.000	47.16	-1.48	45.68	74.00	-28.32	V	peak
4805.000	44.08	2.23	46.31	74.00	-27.69	V	peak
5495.000	39.48	6.24	45.72	74.00	-28.28	V	peak
6870.000	39.08	7.58	46.66	74.00	-27.34	V	peak
1392.000	50.10	-7.11	42.99	74.00	-31.01	H	peak
2134.000	49.98	-3.71	46.27	74.00	-27.73	H	peak
2614.000	48.86	-3.36	45.50	74.00	-28.50	H	peak
4305.000	39.69	7.62	47.31	74.00	-26.69	H	peak
4805.000	45.35	5.54	50.89	74.00	-23.11	H	peak
5955.000	39.39	9.01	48.40	74.00	-25.60	H	peak

Remark:

1. Measuring frequencies from 1 GHz to the 10th harmonic of highest fundamental frequency.
2. Radiated emissions measured in frequency above 1000MHz were made with an instrument using peak/average detector mode.
3. Average test would be performed if the peak result were greater than the average limit or as required by the applicant.
4. Data of measurement within this frequency range shown " --- " in the table above means the reading of emissions are attenuated more than 20dB below the permissible limits or the field strength is too small to be measured.
5. Measurements above show only up to 6 maximum emissions noted, or would be lesser, with " N/A " remark, if no specific emissions from the EUT are recorded (ie: margin>20dB from the applicable limit) and considered that's already beyond the background noise floor.
6. Margin (dB) = Remark result (dBuV/m) – Average limit (dBuV/m).



Compliance Certification Services Inc.

Report No.: T130605L06-RP1 FCC ID: B9Q-MYMET30019 Date of Issue: July 2, 2013

Operation Mode: TX / CH Mid **Test Date:** 2013/6/21
Temperature: 26°C **Tested by:** Francis Lee
Humidity: 56% RH **Polarity:** Ver. / Hor.

Freq. (MHz)	Reading (dBuV)	Correct Factor (dB/m)	Result (dBuV/m)	Limit (dBuV/m)	Margin (dB)	Ant. Pol H/V	Remark
1578.000	49.57	-4.89	44.68	74.00	-29.32	V	peak
2190.000	48.52	-1.55	46.97	74.00	-27.03	V	peak
2704.000	47.96	-1.50	46.46	74.00	-27.54	V	peak
3810.000	40.74	3.47	44.21	74.00	-29.79	V	peak
4880.000	45.85	3.92	49.77	74.00	-24.23	V	peak
6385.000	38.96	6.64	45.60	74.00	-28.40	V	peak
1388.000	50.50	-7.21	43.29	74.00	-30.71	H	peak
2100.000	49.67	-3.78	45.89	74.00	-28.11	H	peak
2796.000	47.78	-2.52	45.26	74.00	-28.74	H	peak
3865.000	40.75	5.18	45.93	74.00	-28.07	H	peak
4880.000	43.71	6.81	50.52	74.00	-23.48	H	peak
6070.000	39.18	8.72	47.90	74.00	-26.10	H	peak

Remark:

1. Measuring frequencies from 1 GHz to the 10th harmonic of highest fundamental frequency.
2. Radiated emissions measured in frequency above 1000MHz were made with an instrument using peak/average detector mode.
3. Average test would be performed if the peak result were greater than the average limit or as required by the applicant.
4. Data of measurement within this frequency range shown " --- " in the table above means the reading of emissions are attenuated more than 20dB below the permissible limits or the field strength is too small to be measured.
5. Measurements above show only up to 6 maximum emissions noted, or would be lesser, with " N/A " remark, if no specific emissions from the EUT are recorded (ie: margin>20dB from the applicable limit) and considered that's already beyond the background noise floor.
6. Margin (dB) = Remark result (dBuV/m) – Average limit (dBuV/m).

**Compliance Certification Services Inc.**

Report No.: T130605L06-RP1

FCC ID: B9Q-MYMET30019 Date of Issue: July 2, 2013

Operation Mode: TX / CH High**Test Date:** 2013/6/21**Temperature:** 26°C**Tested by:** Francis Lee**Humidity:** 56% RH**Polarity:** Ver. / Hor.

Freq. (MHz)	Reading (dBuV)	Correct Factor (dB/m)	Result (dBuV/m)	Limit (dBuV/m)	Margin (dB)	Ant. Pol H/V	Remark
1540.000	50.51	-5.07	45.44	74.00	-28.56	V	peak
2006.000	48.28	-1.44	46.84	74.00	-27.16	V	peak
2706.000	47.76	-1.51	46.25	74.00	-27.75	V	peak
3810.000	40.97	3.47	44.44	74.00	-29.56	V	peak
4960.000	45.45	4.94	50.39	74.00	-23.61	V	peak
5735.000	39.86	5.66	45.52	74.00	-28.48	V	peak
1384.000	50.29	-7.31	42.98	74.00	-31.02	H	peak
2204.000	48.81	-3.67	45.14	74.00	-28.86	H	peak
2858.000	47.63	-2.04	45.59	74.00	-28.41	H	peak
4335.000	40.35	7.40	47.75	74.00	-26.25	H	peak
4960.000	43.24	7.41	50.65	74.00	-23.35	H	peak
6020.000	39.14	8.80	47.94	74.00	-26.06	H	peak

Remark:

1. Measuring frequencies from 1 GHz to the 10th harmonic of highest fundamental frequency.
2. Radiated emissions measured in frequency above 1000MHz were made with an instrument using peak/average detector mode.
3. Average test would be performed if the peak result were greater than the average limit or as required by the applicant.
4. Data of measurement within this frequency range shown " --- " in the table above means the reading of emissions are attenuated more than 20dB below the permissible limits or the field strength is too small to be measured.
5. Measurements above show only up to 6 maximum emissions noted, or would be lesser, with " N/A " remark, if no specific emissions from the EUT are recorded (ie: margin>20dB from the applicable limit) and considered that's already beyond the background noise floor.
6. $Margin (dB) = Remark\ result (dBuV/m) - Average\ limit (dBuV/m)$.



7.7. POWERLINE CONDUCTED EMISSIONS

LIMIT

For an intentional radiator which is designed to be connected to the public utility (AC) power line, the radio frequency voltage that is conducted back onto the AC power line on any frequency or frequencies within the band 150 kHz to 30 MHz shall not exceed 250 microvolts (The limit decreases linearly with the logarithm of the frequency in the range 0.15 MHz to 0.50 MHz). The limits at specific frequency range is listed as follows:

Frequency Range (MHz)	Limits (dB μ V)	
	Quasi-peak	Average
0.15 to 0.50	66 to 56	56 to 46
0.50 to 5	56	46
5 to 30	60	50

Compliance with this provision shall be based on the measurement of the radio frequency voltage between each power line (LINE and NEUTRAL) and ground at the power terminals.

TEST CONFIGURATION

See test photographs attached in Appendix 1 for the actual connections between EUT and support equipment.

TEST PROCEDURE

1. The EUT was placed on a table, which is 0.8m above ground plane.
2. Maximum procedure was performed on the six highest emissions to ensure EUT compliance.
3. Repeat above procedures until all frequency measured were complete.

TEST RESULTS

Not applicable, because the EUT is not connected to AC Main Source.



8 PHOTOGRAPHS OF TEST SETUP

Radiated Emission Setup Photos

Below 1GHz

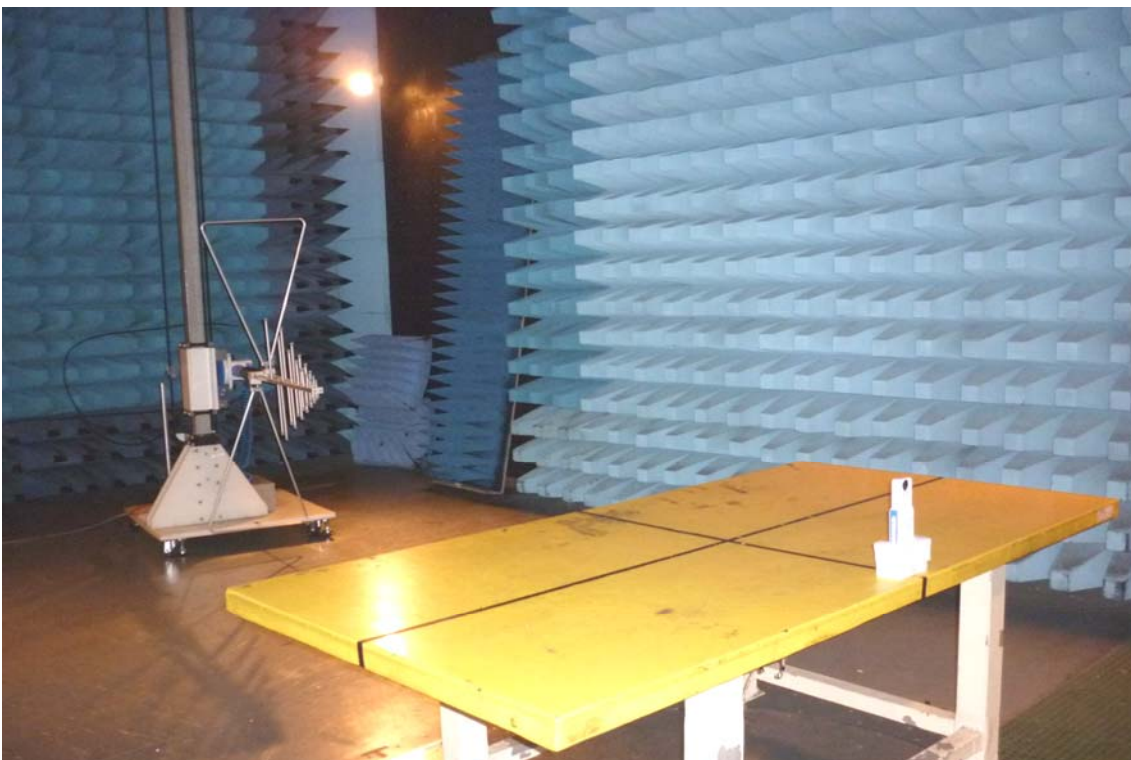
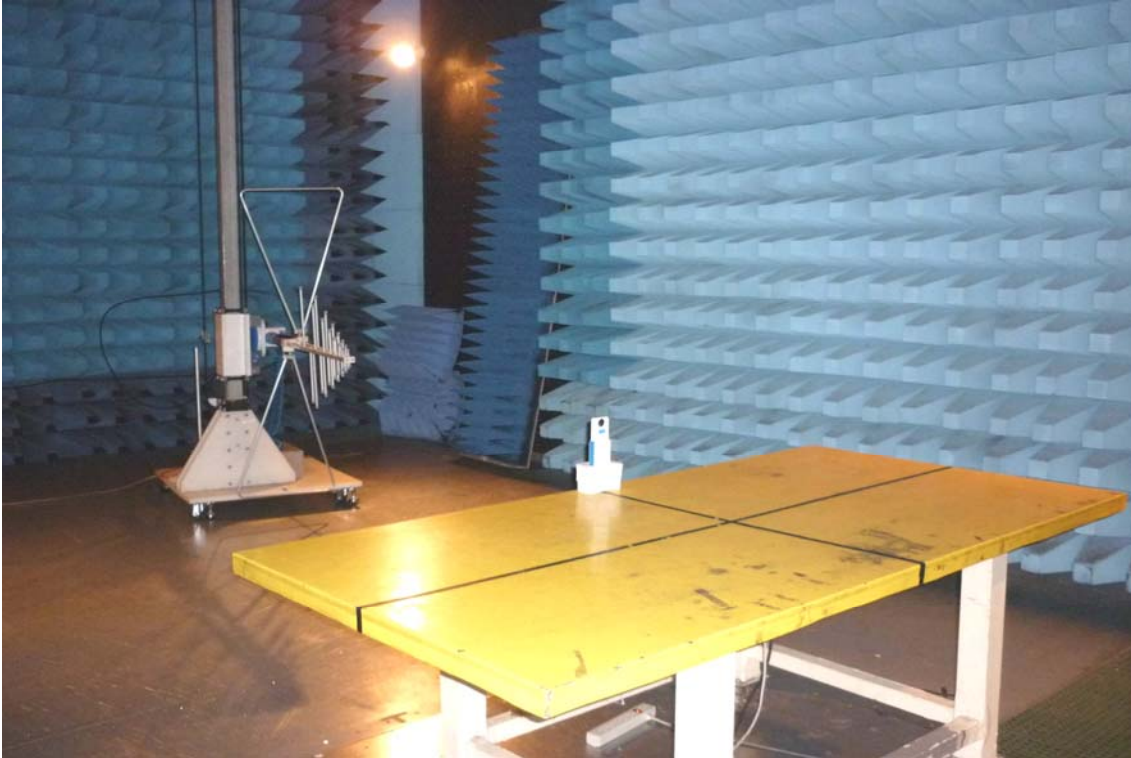



Above 1GHz





Conducted Emission Setup Photo





APPENDIX 1: PHOTOGRAPHS OF EUT

Refer to T130605L06 External Photographs.