

HP WLAN 2.4/5 GHz DB PCB Trace Antennas for the Stellar Module

V1.1

Antenna Report

Model: SNPRC-2350

15NOV2023

HP WLAN 2.4/5 GHz Trace Antenna Data Sheet – Stellar Module Ver 1.1

1) Stellar HW3 Module - Milligrid Connector Option (Top Side /Bottom Side)

Please refer "STELLAR_ANTENNA_DATASHEET_1_1(Photo)"

HP WLAN 2.4/5 GHz Trace Antenna Data Sheet – Stellar Module Ver 1.1

2) Stellar Module HW3 FFC Connector Option (Top Side/Bottom Side)

Please refer "STELLAR_ANTENNA_DATASHEET_1_1(Photo)"

3) Stellar Module Dimensions– 37mm x 40mm

Same for all module variations

Please refer "STELLAR_ANTENNA_DATASHEET_1_1(Photo)"

4) Antenna Layout Details for the STELLAR Module

Antenna 1

(Main Antenna Below)

Antenna 2

(Aux Antenna Below)

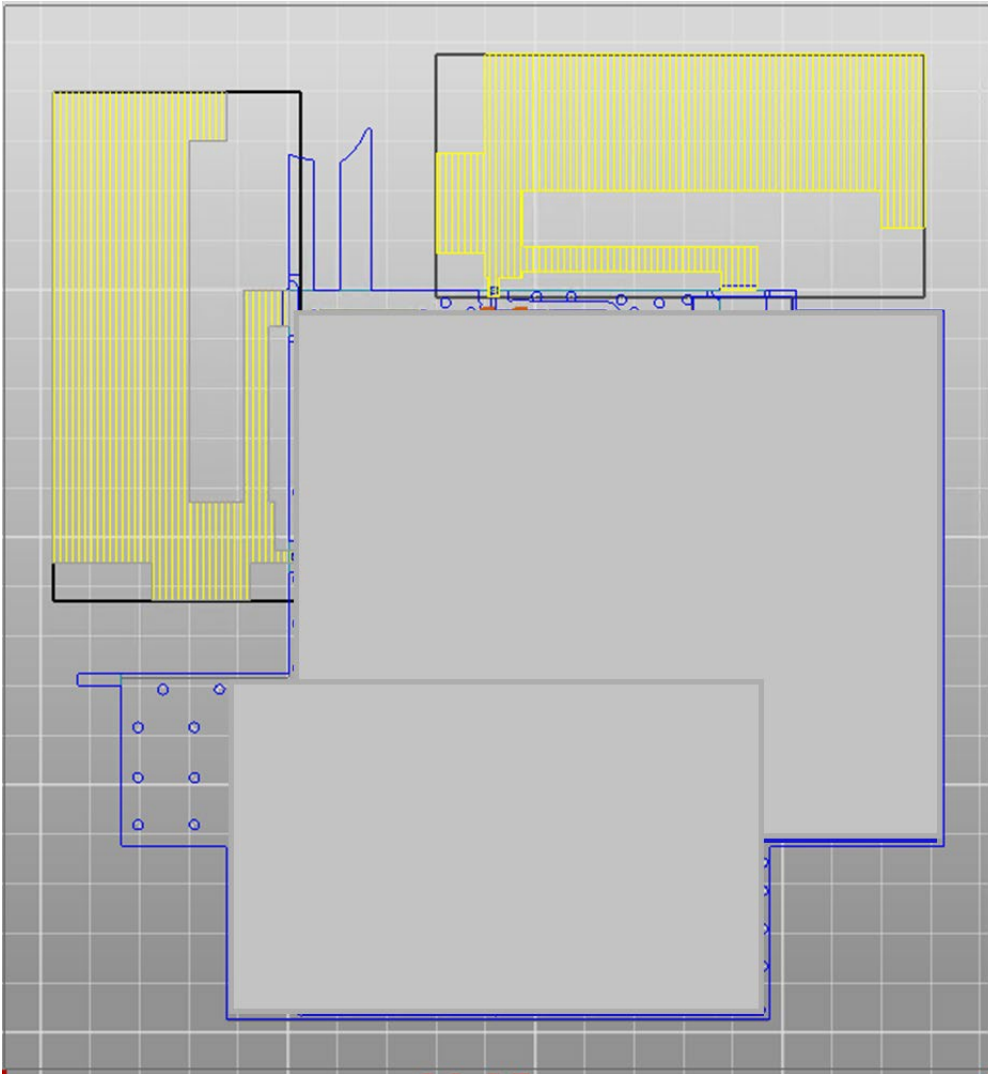

5) Features:

HP WLAN 2.4/5 GHz Trace Antenna Data Sheet – Stellar Module Ver 1.1

- Dual 2.4/5 GHz PCB Trace Antenna: Model – 2019_DB_X02
- Orthogonal antenna orientation for optimal coverage (Diversity)
- 2.4 GHz:
 - 2.4-2.5 GHz Frequency Range
 - VSWR Better than 2.5:1 across Frequency Range
 - Measured Efficiency > 70% across Frequency Range
 - Typical Gain 2.4-2.5 GHz: 3.5 dbi
- 5 GHz:
 - 5.1-5.9 GHz Frequency Range
 - VSWR Better than 2.5:1 across Frequency Range
 - Measured Efficiency > 60% across Frequency Range
 - Typical Gain 5-6 GHz: 4.5 dbi

6) Date of Test:

19OCT2023

7) Location of Test:

SATIMO SG-64 Chamber

Attn: Jim Acree. Measurements performed by Kyle Davis.

MVG Inc.

450 Franklin Gateway, Suite 100

Marietta, GA 30067

HP WLAN 2.4/5 GHz Trace Antenna Data Sheet – Stellar Module Ver 1.1

8) STELLAR WLAN Module in Chamber - (Module Front facing the -Y Direction)

Please refer "STELLAR_ANTENNA_DATASHEET_1_1(Photo)"



MVG SG64 Coordinate System

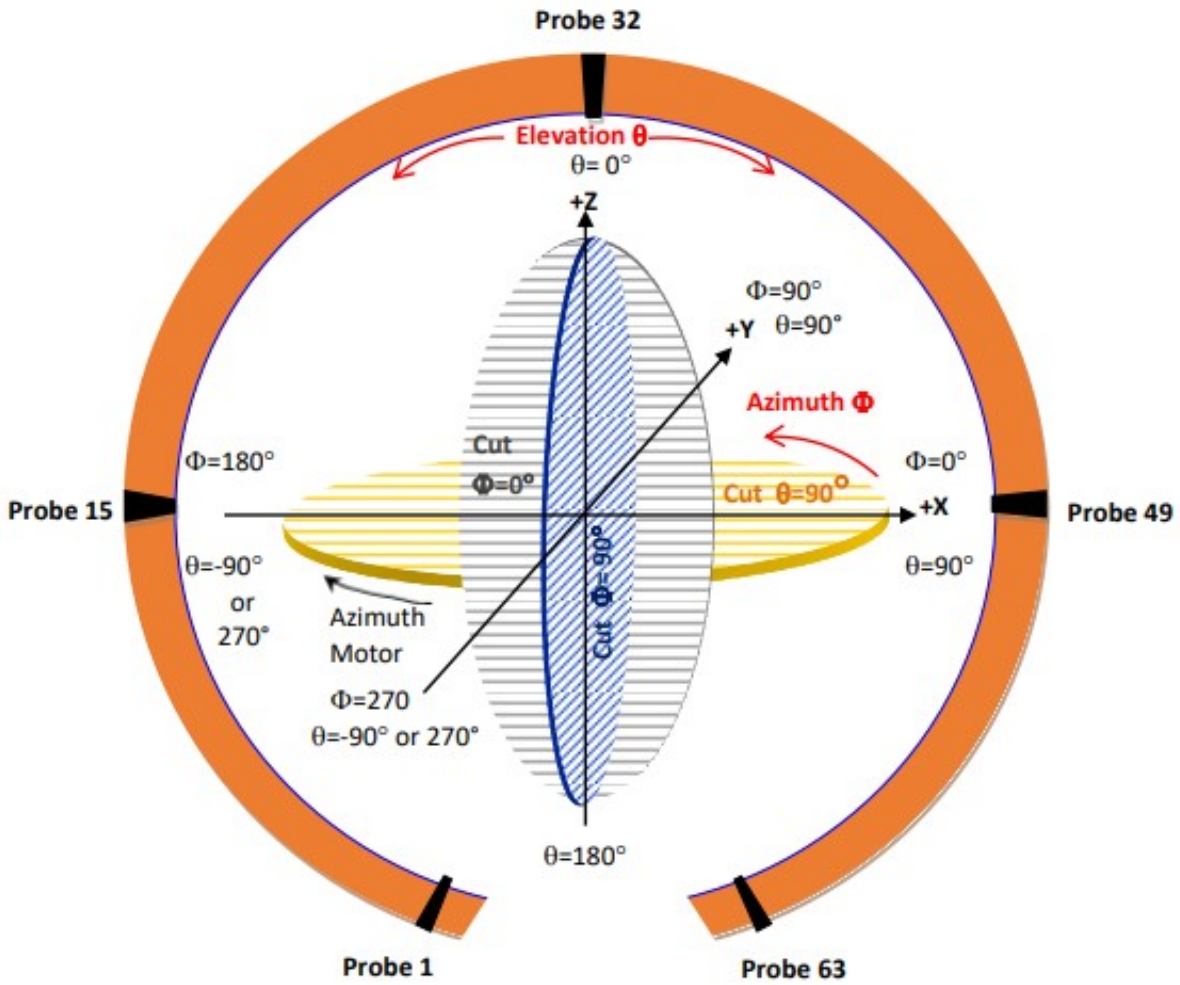

STELLAR Module Antenna Data

1) STELLAR Antenna 1 (MAIN) 2.4-2.5 GHz

Phi=0.00deg

E Total. dB

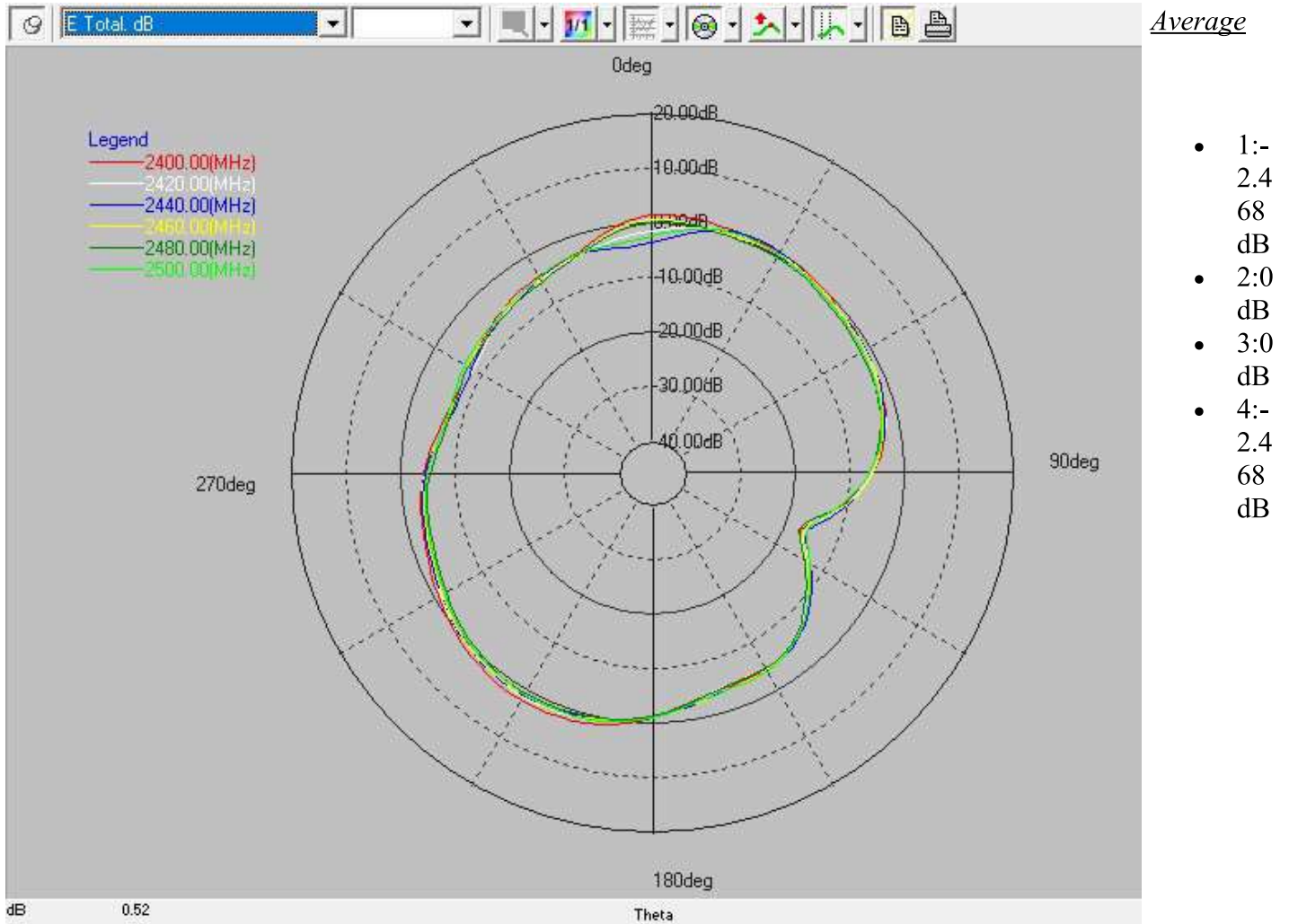

Layer	Max value	Position	Min value	Position	Beam Width	Max/Min	Average	Standard Deviation	Marker 1 pos	Marker 1 value	Marker 2 pos	Marker 2 value
2400(MHz)	2.10 dB	- 153.	- 16.	111.00 deg	60.16 deg	19.01 dB	-2.47 dB	4.27	---	---	---	---

HP WLAN 2.4/5 GHz Trace Antenna Data Sheet – Stellar Module Ver 1.1

		00 deg	91 dB									
2420(MHz)	1.2 6 dB	- 150. 00 deg	- 16. 47 dB	111. 00 deg	---	17.7 2 dB	-3.06 dB	3.98	---	---	---	---
2440(MHz)	1.1 1 dB	- 147. 00 deg	- 15. 74 dB	111. 00 deg	---	16.8 6 dB	-3.07 dB	3.83	---	---	---	---
2460(MHz)	1.0 5 dB	- 150. 00 deg	- 16. 44 dB	111. 00 deg	---	17.4 9 dB	-2.91 dB	4.00	---	---	---	---
2480(MHz)	0.5 6 dB	- 153. 00 deg	- 17. 28 dB	111. 00 deg	---	17.8 5 dB	-3.42 dB	4.00	---	---	---	---
2500(MHz)	0.8 4 dB	- 156. 00 deg	- 15. 72 dB	111. 00 deg	---	16.5 7 dB	-3.18 dB	3.75	---	---	---	---

Phi=90.00deg

E Total. dB

HP WLAN 2.4/5 GHz Trace Antenna Data Sheet – Stellar Module Ver 1.1

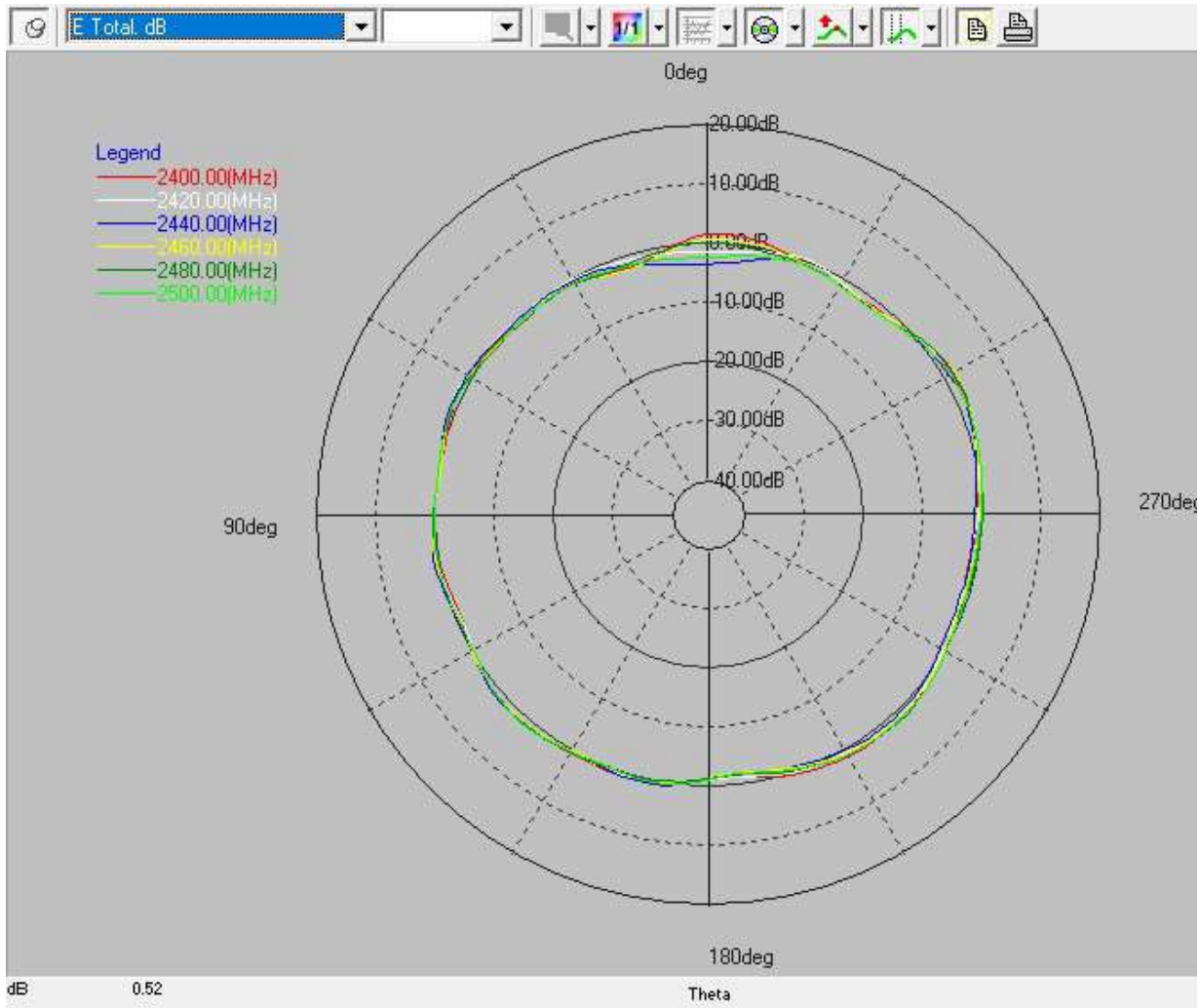

Average

- 1:0.03
431
dB
- 2:0 dB
- 3:0 dB
- 4:0.03
431
dB

dB 0.52

Theta

Layer	Max value	Position	Min value	Position	Beam Width	Max/Min	Average	Standard Deviation	Marker 1 pos	Marker 1 value	Marker 2 pos	Marker 2 value
2400(MHz)	1.70 dB	-63.00 deg	-2.24 dB	18.00 deg	134.84 deg	3.94 dB	0.03 dB	0.93	---	---	---	---
2420(MHz)	1.44 dB	-66.00 deg	-1.71 dB	0.00 deg	---	3.15 dB	-0.05 dB	0.86	---	---	---	---
2440(MHz)	1.31 dB	-66.00 deg	-3.81 dB	0.00 deg	128.23 deg	5.12 dB	-0.36 dB	1.17	---	---	---	---

HP WLAN 2.4/5 GHz Trace Antenna Data Sheet – Stellar Module Ver 1.1

2460(MHz)	1.9 3 dB	- 63.0 0 deg	- 2.6 7 dB	18.0 0 deg	120.06 deg	4.61 dB	-0.13 dB	0.94	---	---	---	---
2480(MHz)	1.8 2 dB	- 63.0 0 deg	- 1.8 6 dB	21.0 0 deg	123.93 deg	3.68 dB	-0.04 dB	0.92	---	---	---	---
2500(MHz)	1.4 6 dB	- 66.0 0 deg	- 2.6 8 dB	3.00 deg	125.78 deg	4.14 dB	-0.20 dB	1.07	---	---	---	---

NF to FF transform Maximum Maximum

E Total. dB

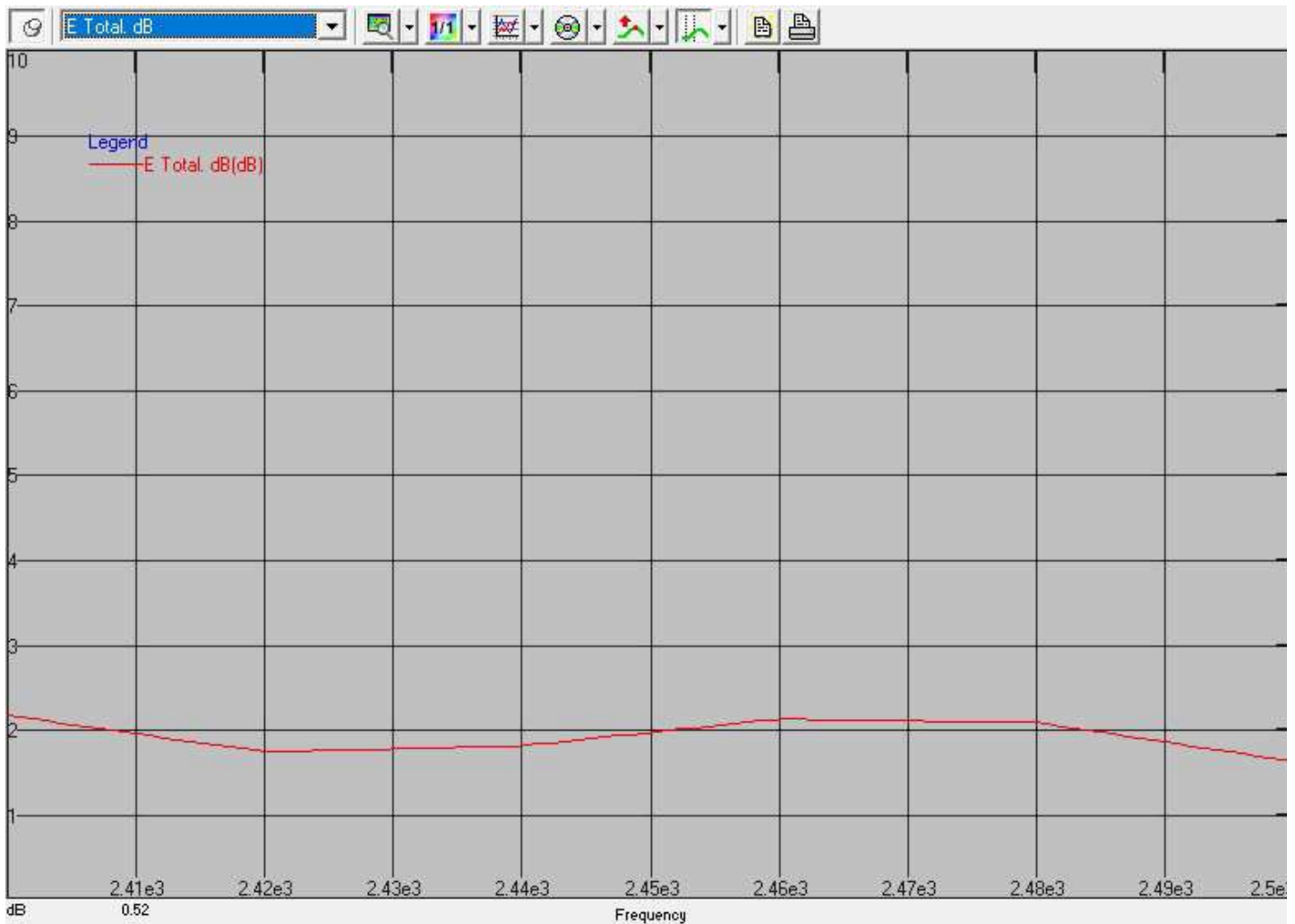

HP WLAN 2.4/5 GHz Trace Antenna Data Sheet – Stellar Module Ver 1.1

Theta=90.00deg

E Total. dB

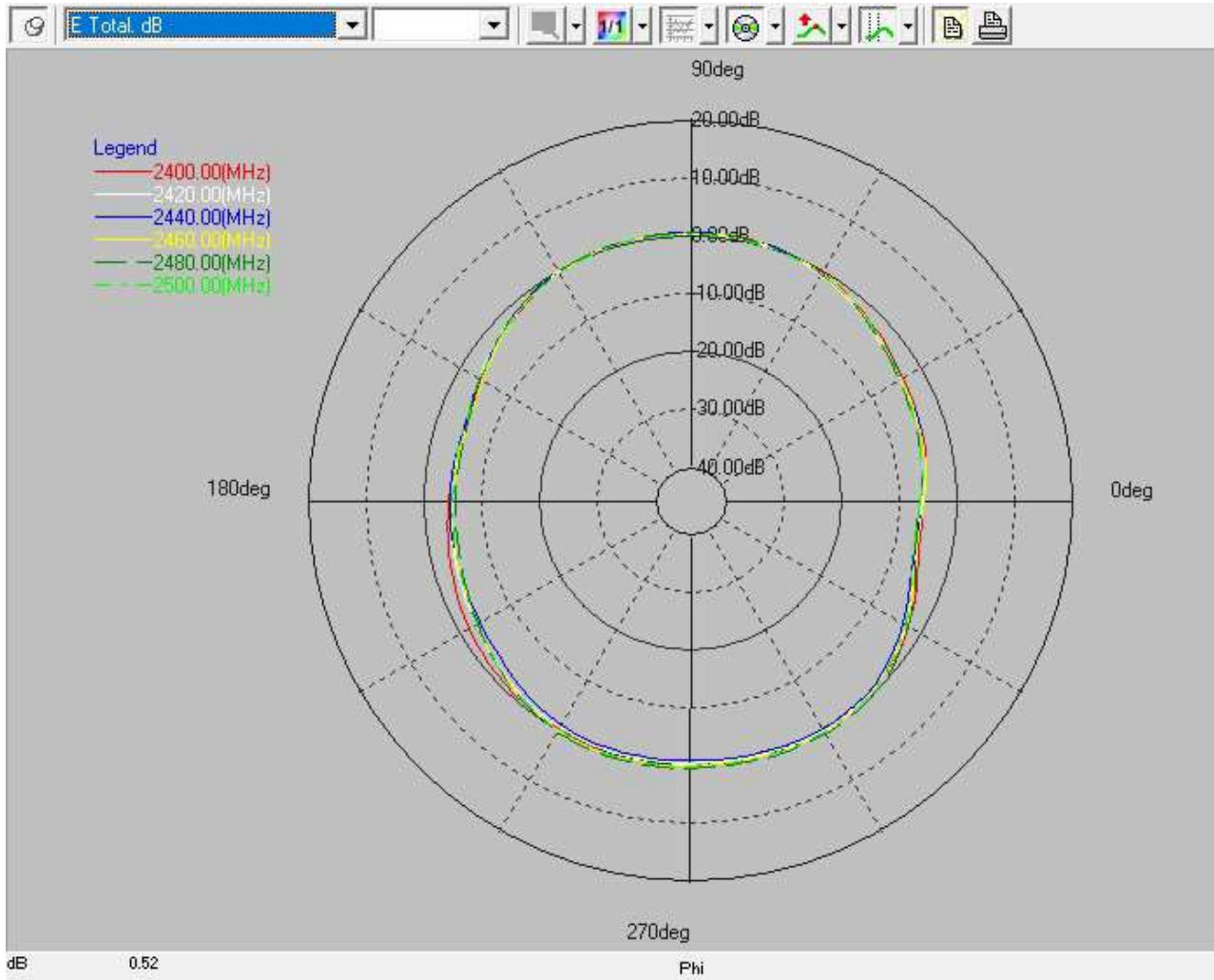

Average

- 1:-
1.
79
dB
- 2:
0
dB
- 3:
0
dB
- 4:-
1.
79
dB

Layer	Max value	Position	Min value	Position	Beam Width	Max/Min	Average	Standard Deviation	Marker 1 pos	Marker 1 value	Marker 2 pos	Marker 2 value
2400(MHz)	0.44 dB	87.00 deg	-5.90 dB	354.00 deg	96.84 deg	6.33 dB	-1.79 dB	1.90	---	---	---	---
2420(MHz)	0.23 dB	99.00 deg	-6.33 dB	351.00 deg	97.10 deg	6.56 dB	-2.02 dB	1.99	---	---	---	---

HP WLAN 2.4/5 GHz Trace Antenna Data Sheet – Stellar Module Ver 1.1

2440(MHz)	0.32 dB	87.00 deg	-6.41 dB	348.00 deg	98.89 deg	6.74 dB	-2.19 dB	1.99	---	---	---	---
2460(MHz)	0.25 dB	90.00 deg	-5.99 dB	351.00 deg	97.08 deg	6.24 dB	-1.92 dB	2.12	---	---	---	---
2480(MHz)	0.58 dB	300.00 deg	-6.52 dB	354.00 deg	111.54 deg	7.10 dB	-1.85 dB	2.38	---	---	---	---
2500(MHz)	0.15 dB	300.00 deg	-6.80 dB	351.00 deg	115.94 deg	6.95 dB	-1.98 dB	2.20	---	---	---	---

HP WLAN 2.4/5 GHz Trace Antenna Data Sheet – Stellar Module Ver 1.1

NF to FF transform Efficiency

Efficiency

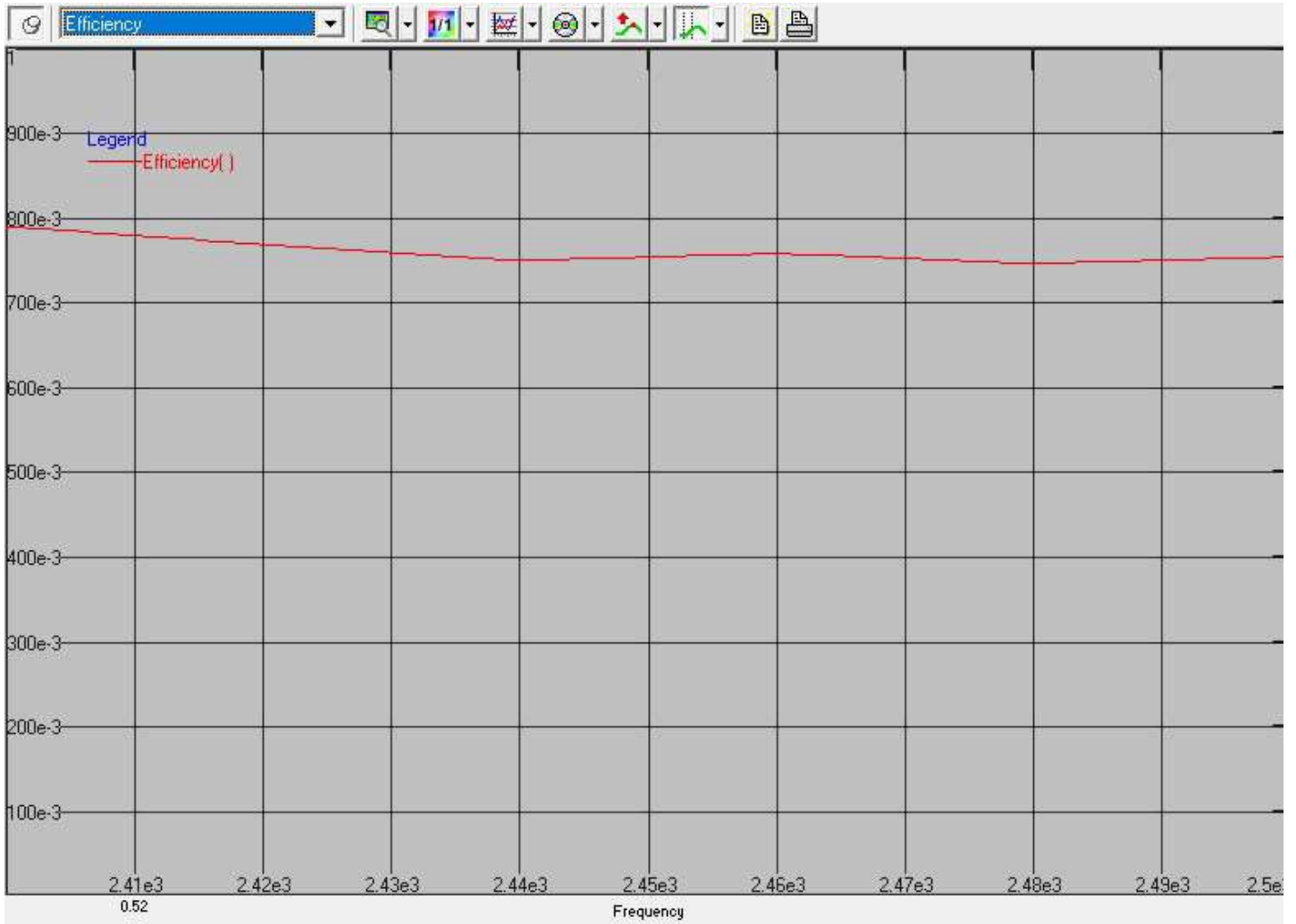

2) STELLAR Antenna 1 (MAIN) 5.0-6.0 GHz

Phi=0.00deg

E Total. dB

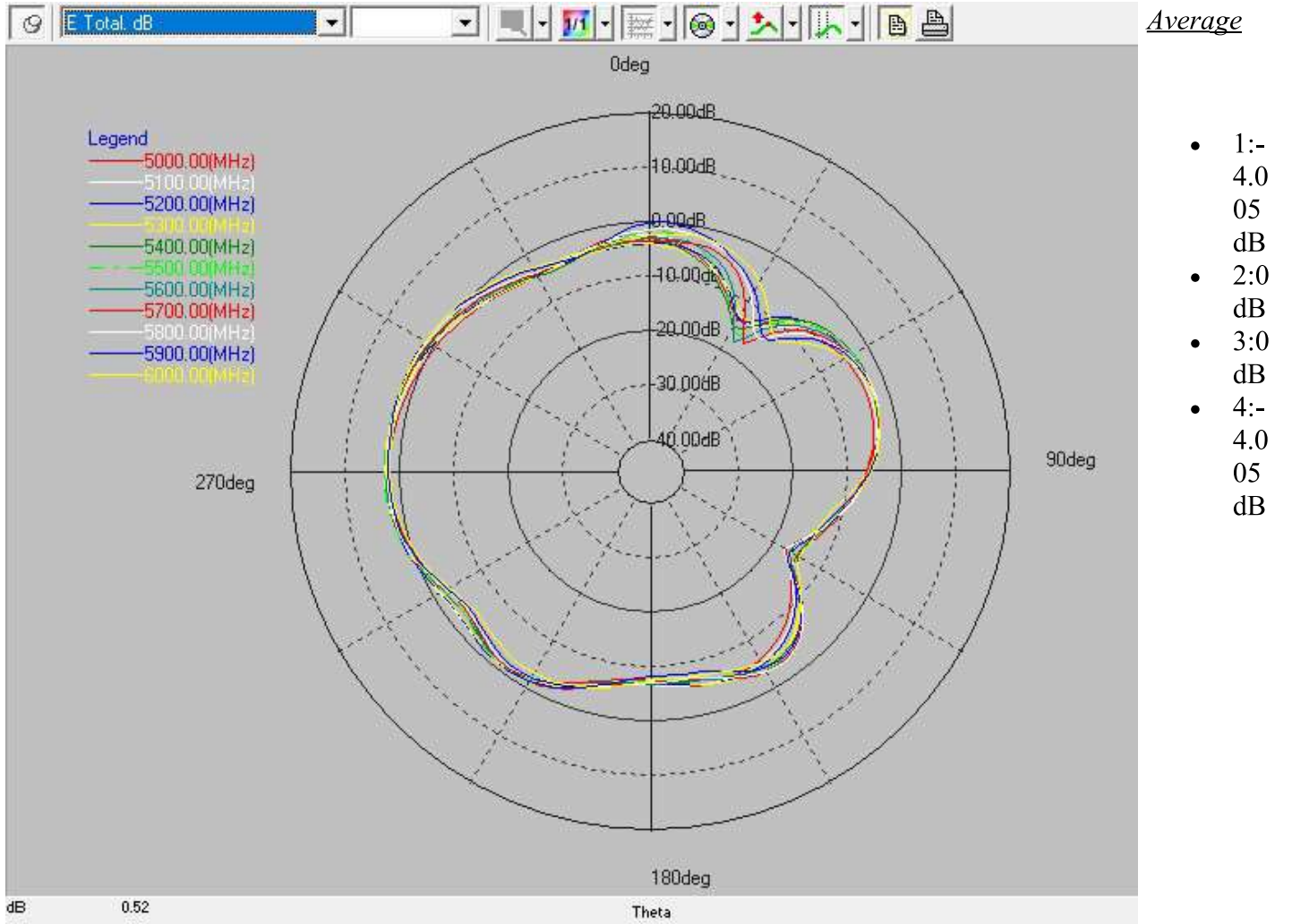

Average

- 1:- 4.0 05 dB
- 2:0 dB
- 3:0 dB
- 4:- 4.0 05 dB

Layer	Max value	Position	Min value	Position	Beam Width	Max/Min	Average	Standard Deviation	Marker 1 pos	Marker 1 value	Marker 2 pos	Marker 2 value
5000(MHz)	1.87 dB	-90.00 deg	-15.18 dB	120.00 deg	60.43 deg	17.05 dB	-4.01 dB	4.27	---	---	---	---

HP WLAN 2.4/5 GHz Trace Antenna Data Sheet – Stellar Module Ver 1.1

5100(MHz)	2.3 3 dB	- 90.0 0 deg	- 16. 41 dB	120. 00 deg	61.17 deg	18.7 4 dB	-3.67 dB	4.45	---	---	---	---
5200(MHz)	2.6 7 dB	- 90.0 0 deg	- 16. 05 dB	120. 00 deg	59.41 deg	18.7 2 dB	-3.56 dB	4.37	---	---	---	---
5300(MHz)	2.8 0 dB	- 90.0 0 deg	- 16. 28 dB	117. 00 deg	57.20 deg	19.0 8 dB	-3.61 dB	4.40	---	---	---	---
5400(MHz)	2.6 0 dB	- 90.0 0 deg	- 15. 47 dB	30.0 0 deg	60.16 deg	18.0 7 dB	-3.62 dB	4.40	---	---	---	---
5500(MHz)	2.7 5 dB	- 90.0 0 deg	- 16. 26 dB	33.0 0 deg	61.19 deg	19.0 2 dB	-3.44 dB	4.63	---	---	---	---
5600(MHz)	2.5 1 dB	- 90.0 0 deg	- 17. 84 dB	33.0 0 deg	61.56 deg	20.3 5 dB	-3.57 dB	4.56	---	---	---	---
5700(MHz)	2.4 6 dB	- 87.0 0 deg	- 17. 18 dB	120. 00 deg	62.64 deg	19.6 4 dB	-3.57 dB	4.54	---	---	---	---
5800(MHz)	2.4 3 dB	- 87.0 0 deg	- 17. 50 dB	120. 00 deg	66.18 deg	19.9 3 dB	-3.28 dB	4.51	---	---	---	---
5900(MHz)	2.2 9 dB	- 78.0 0 deg	- 16. 40 dB	120. 00 deg	68.84 deg	18.6 9 dB	-3.33 dB	4.55	---	---	---	---
6000(MHz)	2.0 4 dB	- 72.0 0 deg	- 14. 27 dB	120. 00 deg	71.70 deg	16.3 2 dB	-3.57 dB	4.18	---	---	---	---

HP WLAN 2.4/5 GHz Trace Antenna Data Sheet – Stellar Module Ver 1.1

Phi=90.00deg

E Total. dB

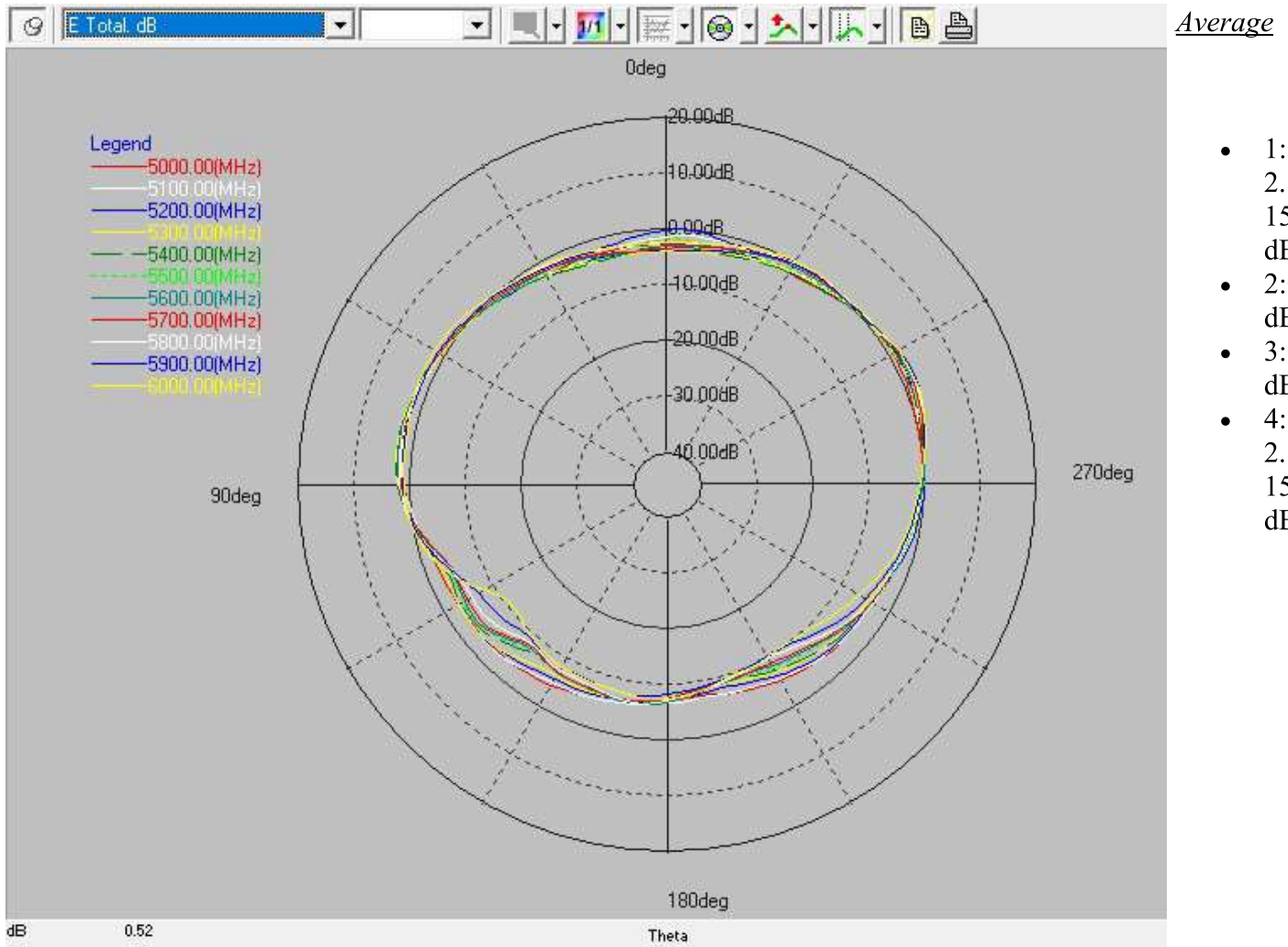

dB 0.52

Theta

Layer	Max value	Position	Min value	Position	Beam Width	Max/Min	Average	Standard Deviation	Marker 1 pos	Marker 1 value	Marker 2 pos	Marker 2 value
5000(MHz)	1.83 dB	78.00 deg	-7.56 dB	-171.00 deg	58.09 deg	9.39 dB	-2.12 dB	2.47	---	---	---	---
5100(MHz)	1.98 dB	78.00 deg	-7.2	-171.	58.80 deg	9.18 dB	-2.00 dB	2.54	---	---	---	---

HP WLAN 2.4/5 GHz Trace Antenna Data Sheet – Stellar Module Ver 1.1

			1 dB	00 deg								
5200(MHz)	2.4 1 dB	81.0 0 deg	- 8.2 3 dB	- 165. 00 deg	51.76 deg	10.6 4 dB	-2.16 dB	2.90	---	---	---	---
5300(MHz)	2.8 1 dB	81.0 0 deg	- 8.9 5 dB	- 168. 00 deg	47.42 deg	11.7 6 dB	-2.30 dB	3.12	---	---	---	---
5400(MHz)	2.6 4 dB	81.0 0 deg	- 9.1 3 dB	- 165. 00 deg	49.63 deg	11.7 8 dB	-2.44 dB	3.21	---	---	---	---
5500(MHz)	2.4 3 dB	81.0 0 deg	- 9.0 3 dB	- 162. 00 deg	51.88 deg	11.4 6 dB	-2.27 dB	3.34	---	---	---	---
5600(MHz)	2.4 2 dB	81.0 0 deg	- 9.1 0 dB	- 159. 00 deg	53.50 deg	11.5 2 dB	-2.28 dB	3.38	---	---	---	---
5700(MHz)	2.2 0 dB	81.0 0 deg	- 9.3 6 dB	- 162. 00 deg	58.59 deg	11.5 6 dB	-2.32 dB	3.54	---	---	---	---
5800(MHz)	2.2 6 dB	- 66.0 0 deg	- 9.8 1 dB	- 150. 00 deg	67.68 deg	12.0 8 dB	-2.11 dB	3.77	---	---	---	---
5900(MHz)	2.3 2 dB	- 66.0 0 deg	- 10. 37 dB	- 150. 00 deg	63.47 deg	12.6 9 dB	-2.33 dB	4.11	---	---	---	---
6000(MHz)	2.2 2 dB	- 69.0 0 deg	- 10. 96 dB	129. 00 deg	69.56 deg	13.1 8 dB	-2.38 dB	4.33	---	---	---	---

NF to FF transform Maximum Maximum

E Total. dB

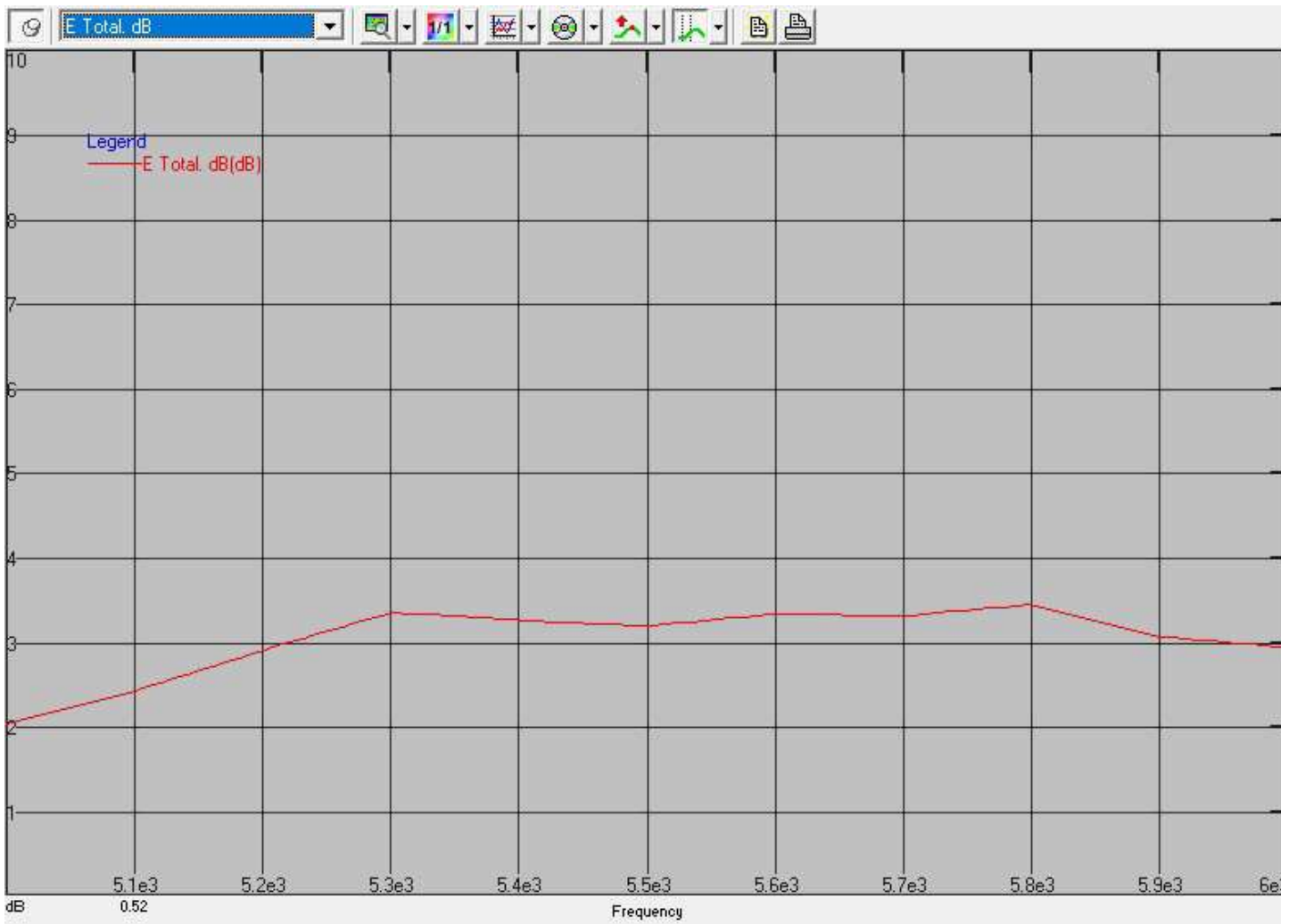

Theta=90.00deg

E Total. dB

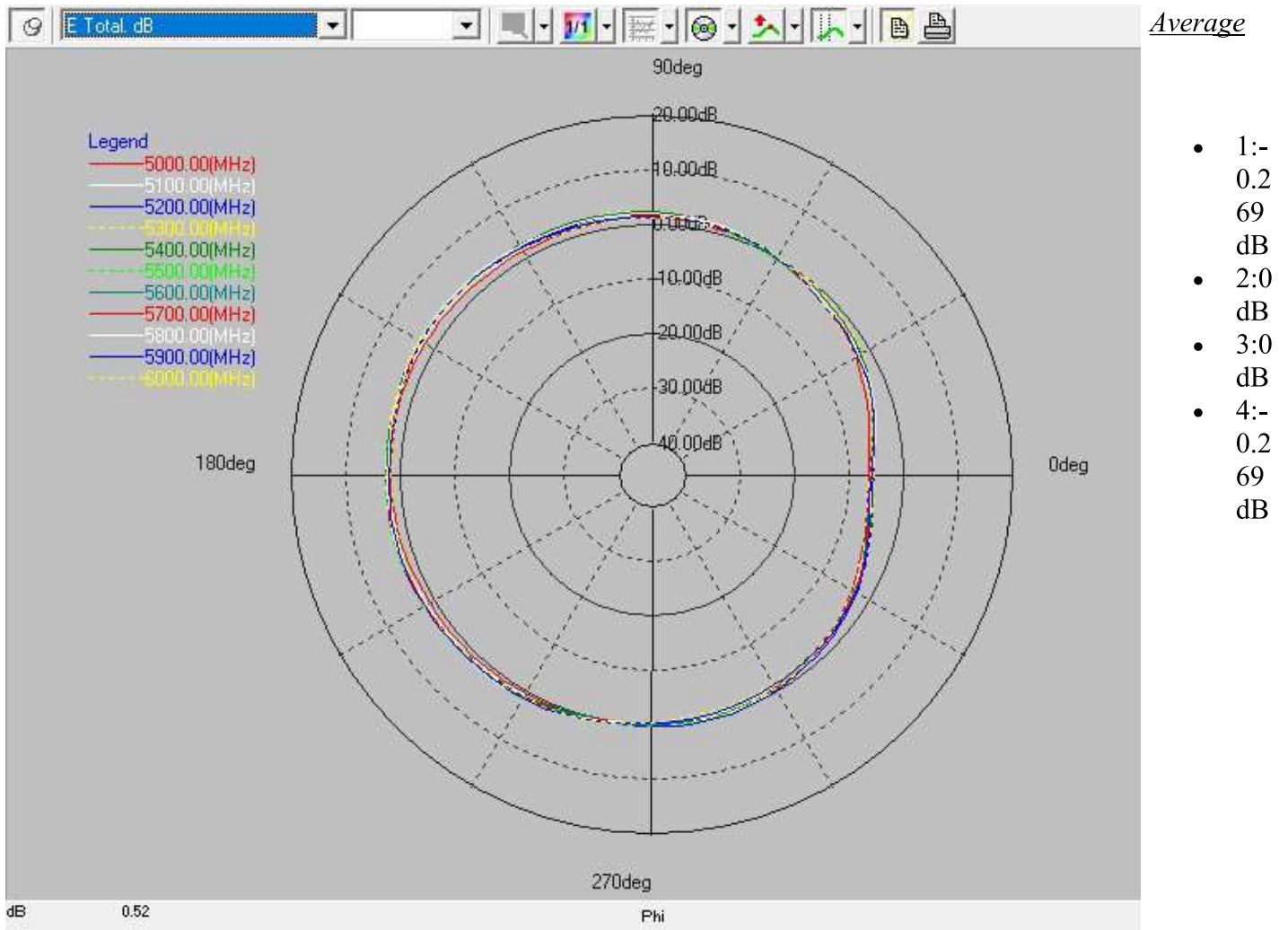

- 1:- 0.2 69 dB
- 2:0 dB
- 3:0 dB
- 4:- 0.2 69 dB

Layer	Max value	Position	Min value	Position	Beam Width	Max/Min	Average	Standard Deviation	Marker 1 pos	Marker 1 value	Marker 2 pos	Marker 2 value
5000(MHz)	2.04 dB	159.00 deg	-6.33 dB	357.00 deg	253.68 deg	8.37 dB	-0.27 dB	2.41	---	---	---	---

HP WLAN 2.4/5 GHz Trace Antenna Data Sheet – Stellar Module Ver 1.1

5100(MHz)	2.4 3 dB	159. 00 deg	- 5.7 5 dB	354. 00 deg	250.85 deg	8.18 dB	0.11 dB	2.37	---	---	---	---
5200(MHz)	2.8 7 dB	153. 00 deg	- 5.5 1 dB	0.00 deg	233.01 deg	8.38 dB	0.41 dB	2.37	---	---	---	---
5300(MHz)	3.2 9 dB	150. 00 deg	- 5.3 9 dB	0.00 deg	182.91 deg	8.68 dB	0.53 dB	2.46	---	---	---	---
5400(MHz)	3.0 2 dB	147. 00 deg	- 5.8 2 dB	0.00 deg	187.35 deg	8.84 dB	0.37 dB	2.53	---	---	---	---
5500(MHz)	2.9 5 dB	144. 00 deg	- 6.0 9 dB	357. 00 deg	201.34 deg	9.03 dB	0.41 dB	2.62	---	---	---	---
5600(MHz)	3.0 9 dB	144. 00 deg	- 6.1 8 dB	357. 00 deg	191.17 deg	9.27 dB	0.32 dB	2.62	---	---	---	---
5700(MHz)	3.0 7 dB	147. 00 deg	- 6.1 8 dB	357. 00 deg	194.04 deg	9.26 dB	0.33 dB	2.59	---	---	---	---
5800(MHz)	3.1 8 dB	144. 00 deg	- 5.8 4 dB	357. 00 deg	195.00 deg	9.01 dB	0.42 dB	2.52	---	---	---	---
5900(MHz)	2.7 5 dB	147. 00 deg	- 5.9 5 dB	357. 00 deg	204.72 deg	8.70 dB	0.15 dB	2.44	---	---	---	---
6000(MHz)	2.7 3 dB	147. 00 deg	- 6.2 9 dB	354. 00 deg	207.90 deg	9.02 dB	-0.07 dB	2.53	---	---	---	---

NF to FF transform Efficiency

HP WLAN 2.4/5 GHz Trace Antenna Data Sheet – Stellar Module Ver 1.1

Efficiency

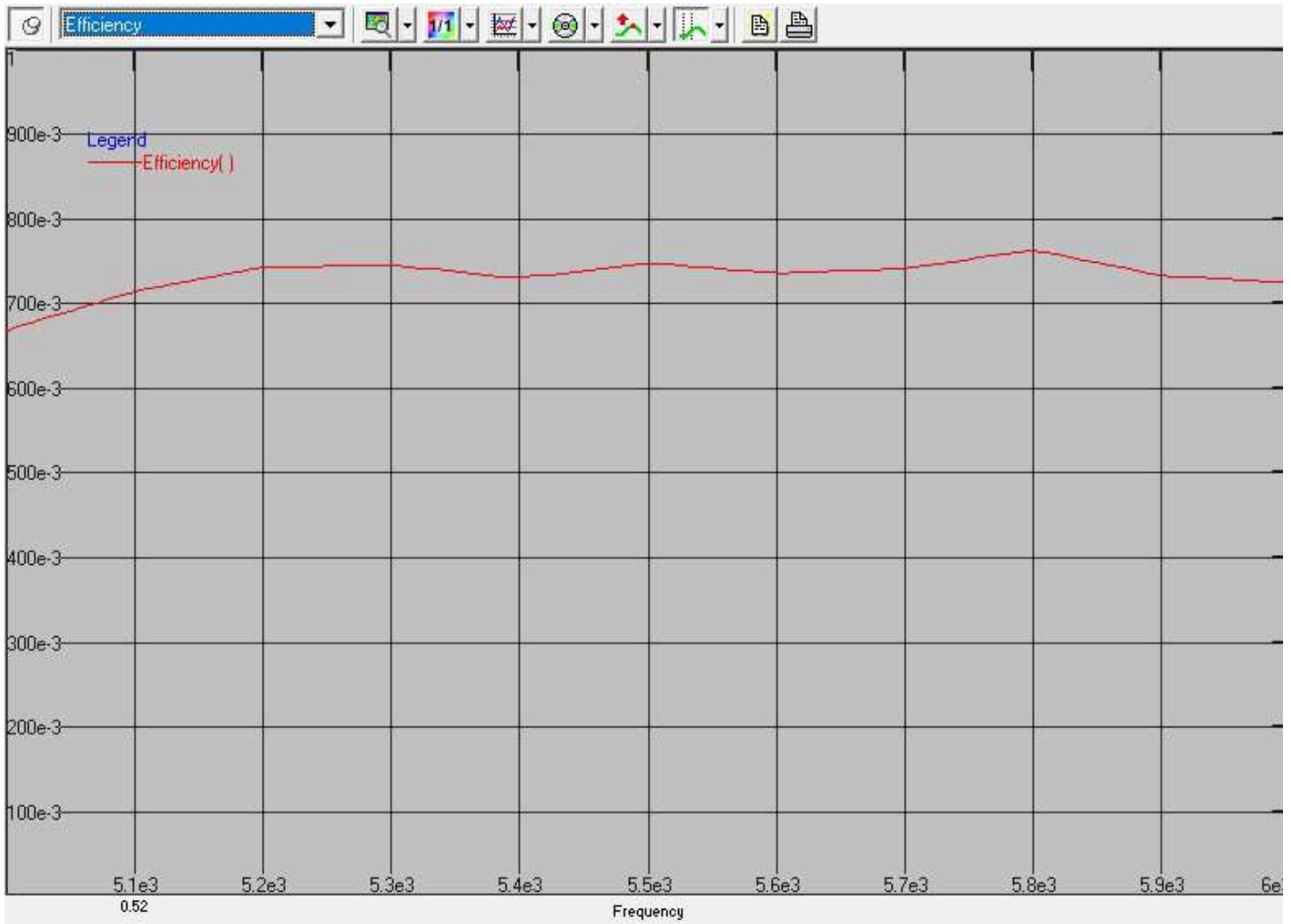

3)STELLAR Antenna 2 (AUX) 2.4-2.5 GHz

Phi=0.00deg

E Total. dB

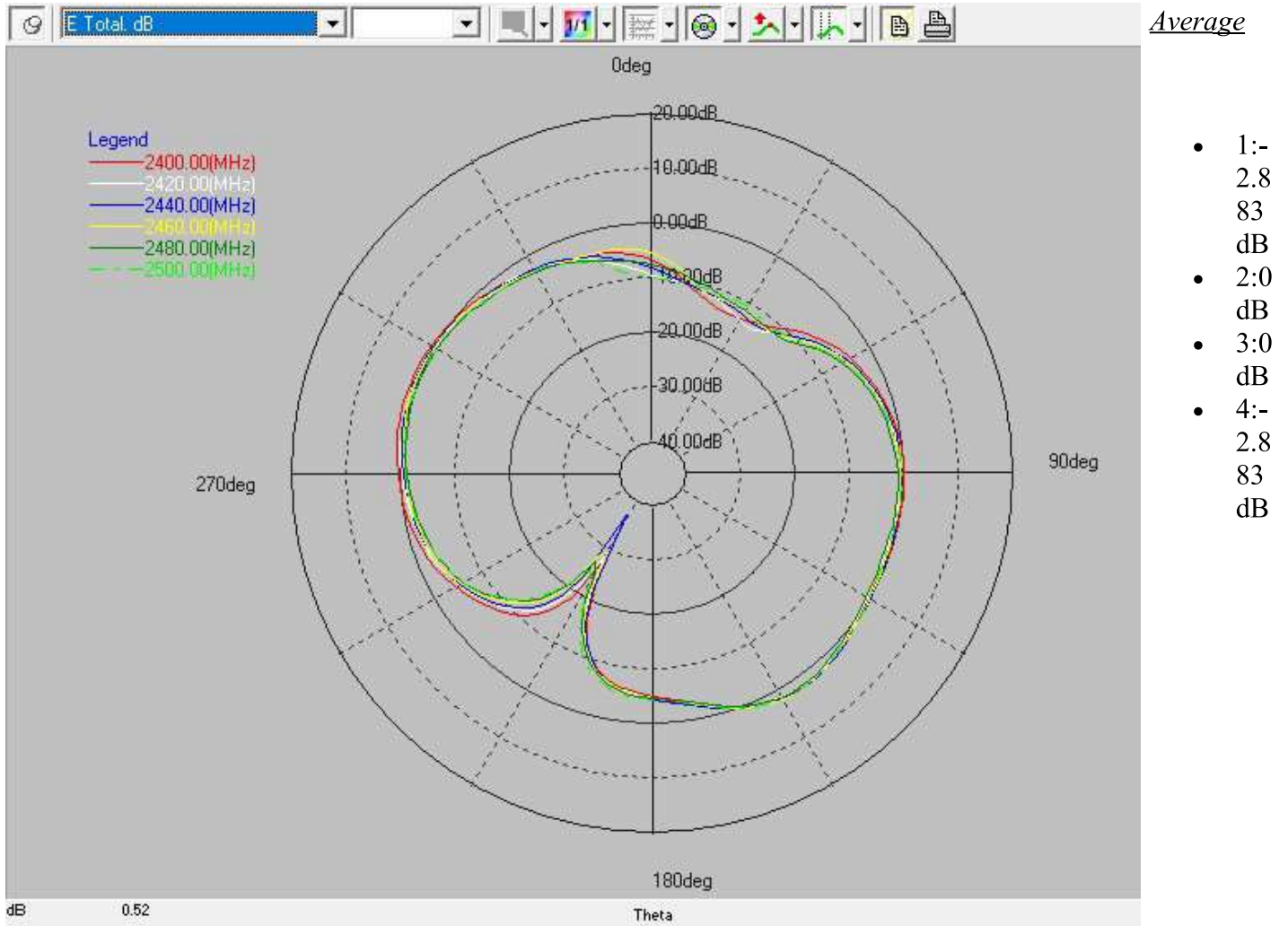

Layer	Max value	Position	Min value	Position	Beam Width	Max/Min	Average	Standard Deviation	Marker 1 pos	Marker 1 value	Marker 2 pos	Marker 2 value
2400(MHz)	1.91 dB	144.00 deg	-26.30 dB	-150.00 deg	87.81 deg	28.21 dB	-2.88 dB	5.58	---	---	---	---

HP WLAN 2.4/5 GHz Trace Antenna Data Sheet – Stellar Module Ver 1.1

2420(MHz)	1.7 2 dB	144. 00 deg	- 28. 11 dB	- 150. 00 deg	86.45 deg	29.8 3 dB	-3.37 dB	5.62	---	---	---	---
2440(MHz)	2.0 6 dB	144. 00 deg	- 36. 97 dB	- 150. 00 deg	84.18 deg	39.0 3 dB	-3.20 dB	6.06	---	---	---	---
2460(MHz)	2.0 4 dB	144. 00 deg	- 29. 14 dB	- 150. 00 deg	80.18 deg	31.1 8 dB	-3.27 dB	5.76	---	---	---	---
2480(MHz)	1.6 9 dB	144. 00 deg	- 26. 83 dB	- 147. 00 deg	78.21 deg	28.5 2 dB	-3.73 dB	5.46	---	---	---	---
2500(MHz)	1.9 4 dB	144. 00 deg	- 25. 01 dB	- 147. 00 deg	82.11 deg	26.9 5 dB	-3.52 dB	5.48	---	---	---	---

HP WLAN 2.4/5 GHz Trace Antenna Data Sheet – Stellar Module Ver 1.1
 Phi=90.00deg

E Total. dB

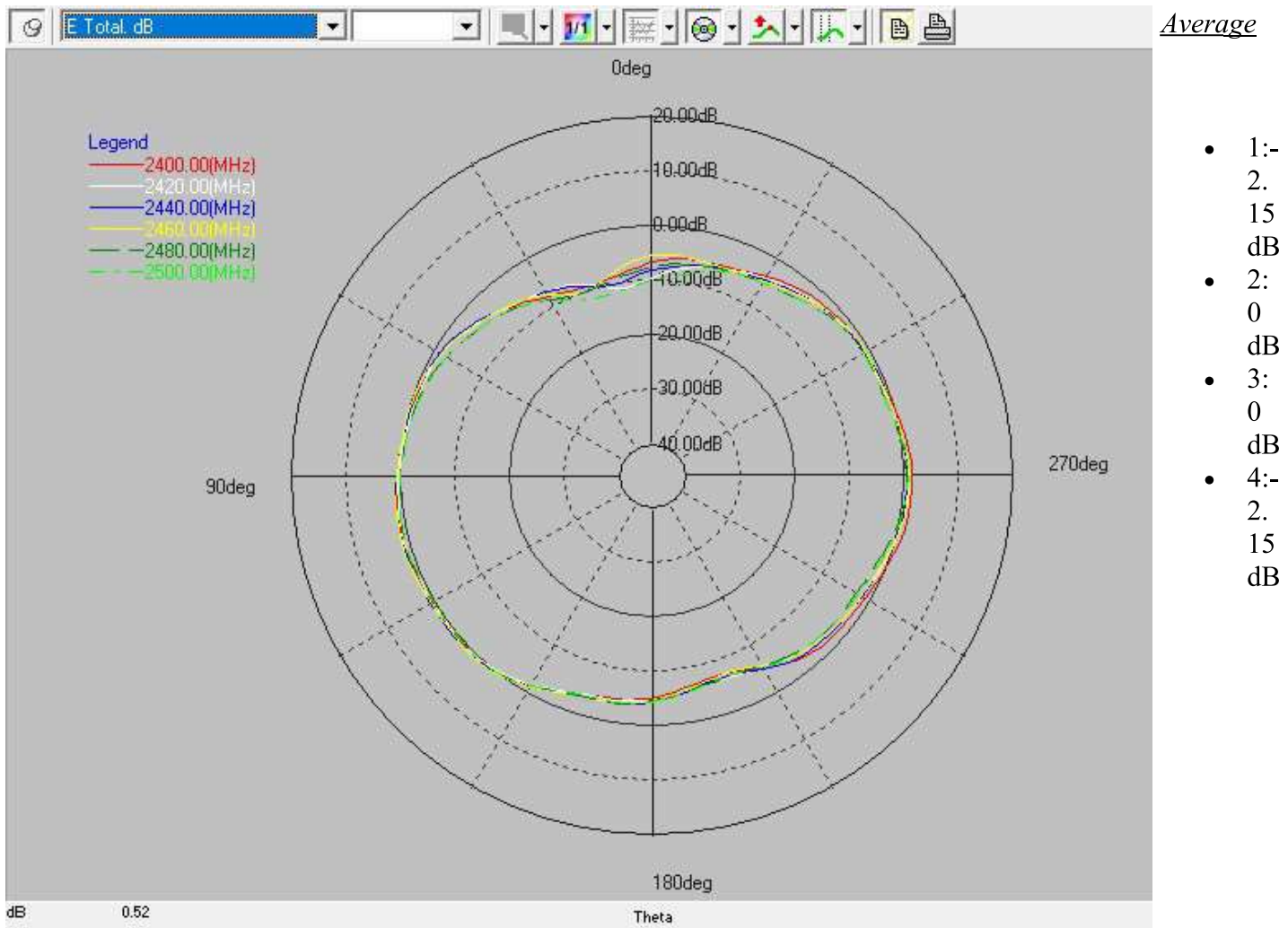

- 1:-
2.
15
dB
- 2:
0
dB
- 3:
0
dB
- 4:-
2.
15
dB

Layer	Max value	Position	Min value	Position	Beam Width	Max/Min	Average	Standard Deviation	Marker 1 pos	Marker 1 value	Marker 2 pos	Marker 2 value
2400(MHz)	1.70 dB	-93.00 deg	-9.54 dB	18.00 deg	75.67 deg	11.23 dB	-2.15 dB	3.20	---	---	---	---
2420(MHz)	0.93 dB	102.00 deg	-11.33 dB	9.00 deg	96.15 deg	12.26 dB	-2.45 dB	3.22	---	---	---	---

HP WLAN 2.4/5 GHz Trace Antenna Data Sheet – Stellar Module Ver 1.1

2440(MHz)	1.36 dB	105.00 deg	-10.45 dB	12.00 deg	94.76 deg	11.80 dB	-2.26 dB	3.20	---	---	---	---
2460(MHz)	1.46 dB	105.00 deg	-10.29 dB	21.00 deg	91.59 deg	11.76 dB	-2.23 dB	3.11	---	---	---	---
2480(MHz)	0.85 dB	105.00 deg	-10.22 dB	18.00 deg	91.10 deg	11.06 dB	-2.80 dB	3.07	---	---	---	---
2500(MHz)	0.90 dB	-90.00 deg	-12.05 dB	15.00 deg	67.46 deg	12.94 dB	-2.88 dB	3.51	---	---	---	---

NF to FF transform Maximum Maximum

E Total. dB

HP WLAN 2.4/5 GHz Trace Antenna Data Sheet – Stellar Module Ver 1.1

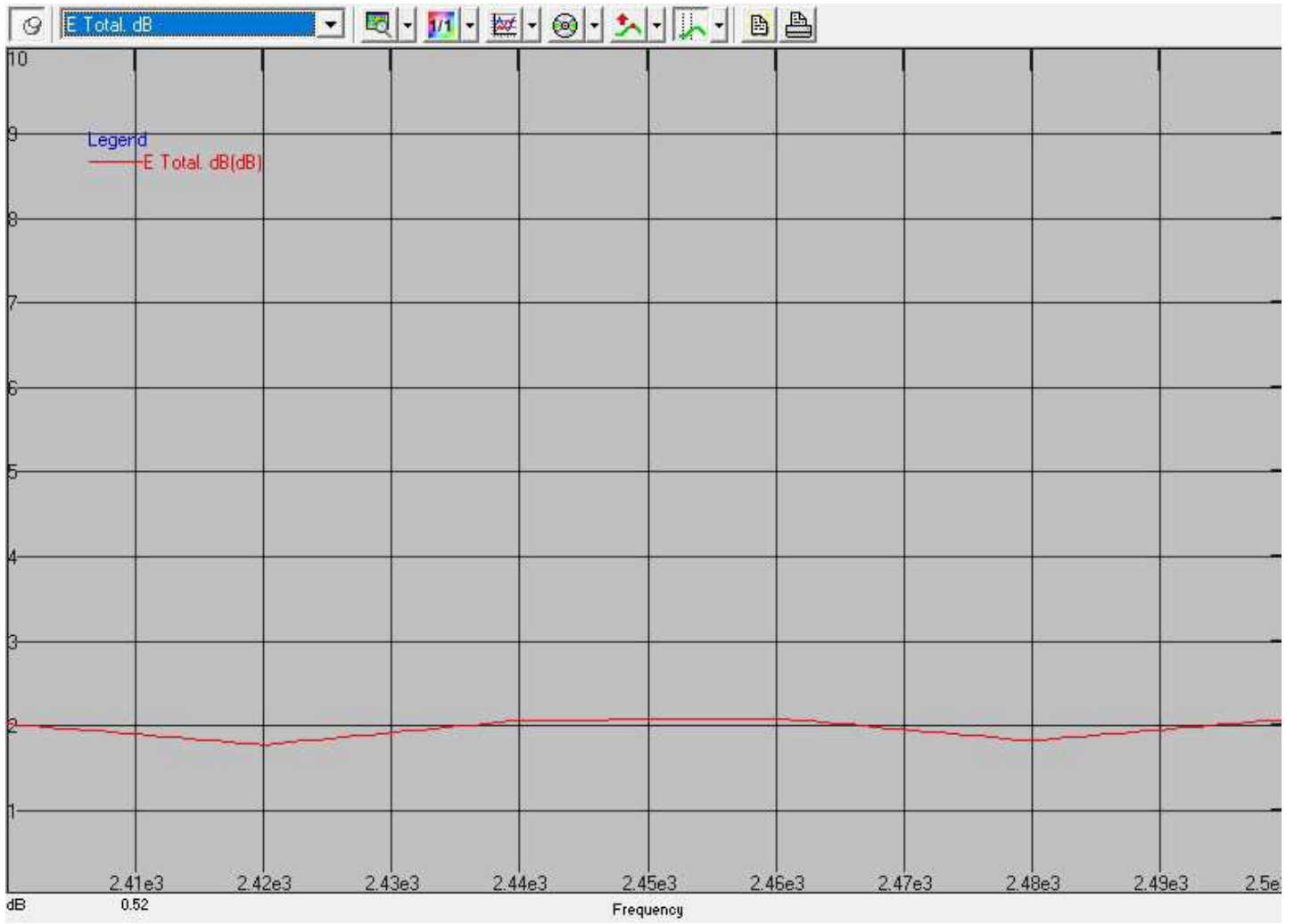

HP WLAN 2.4/5 GHz Trace Antenna Data Sheet – Stellar Module Ver 1.1
 Theta=90.00deg

E Total. dB

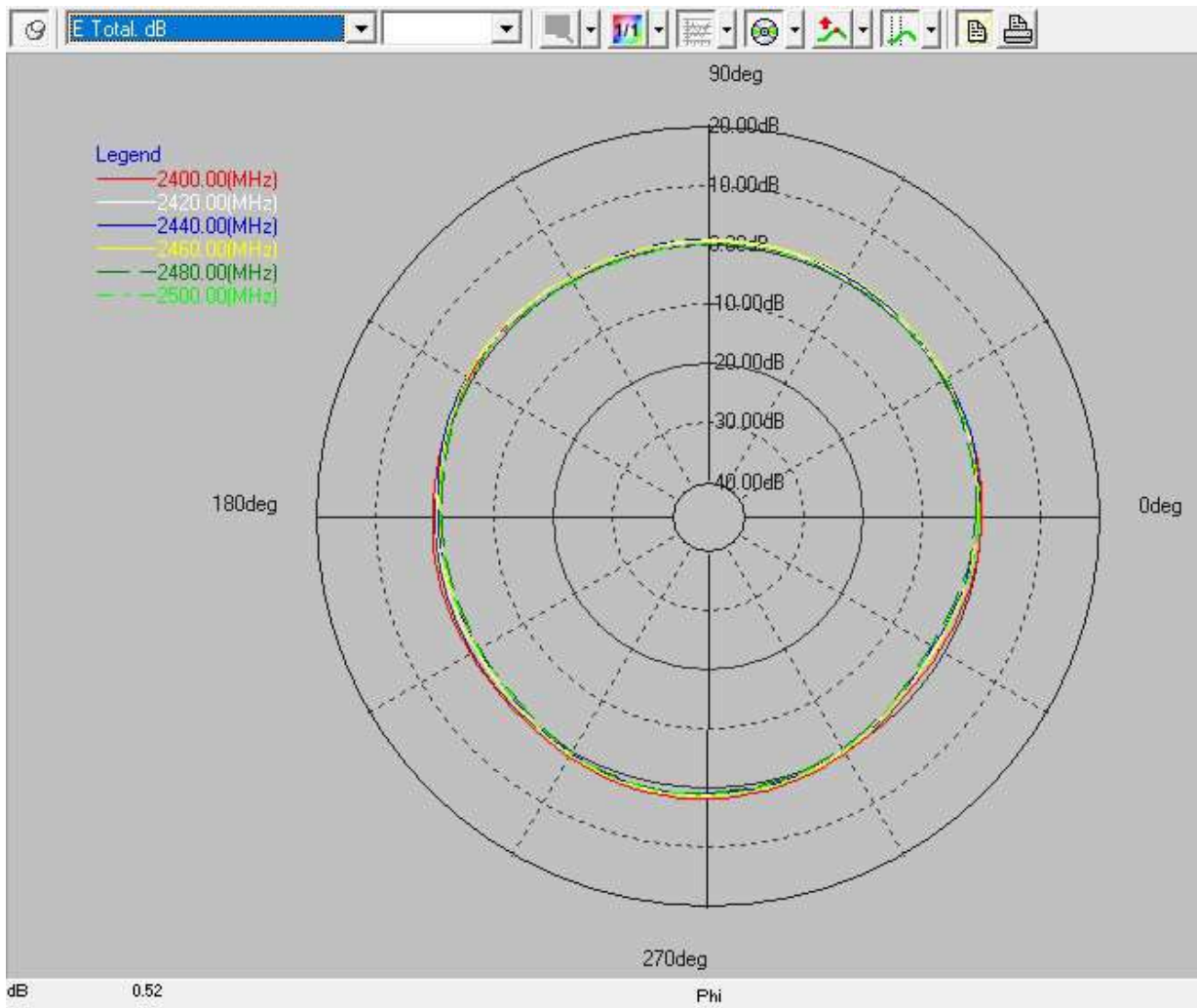

Average

- 1:0.5308 dB
- 2:0 dB
- 3:0 dB
- 4:0.5308 dB

Layer	Max value	Position	Min value	Position	Beam Width	Max/Min	Average	Standard Deviation	Marker 1 pos	Marker 1 value	Marker 2 pos	Marker 2 value
2400(MHz)	1.71 dB	264.00 deg	-0.99 dB	324.00 deg	---	2.70 dB	0.53 dB	0.58	---	---	---	---
2420(MHz)	0.97 dB	261.00 deg	-1.85 dB	327.00 deg	---	2.82 dB	0.02 dB	0.72	---	---	---	---

HP WLAN 2.4/5 GHz Trace Antenna Data Sheet – Stellar Module Ver 1.1

2440(MHz)	1.1 3 dB	141. 00 deg	- 2.0 7 dB	330. 00 deg	---	3.20 dB	0.07 dB	0.85	---	---	---	---
2460(MHz)	1.2 8 dB	261. 00 deg	- 1.6 9 dB	327. 00 deg	---	2.97 dB	0.12 dB	0.83	---	---	---	---
2480(MHz)	0.8 1 dB	261. 00 deg	- 2.4 7 dB	327. 00 deg	---	3.27 dB	-0.49 dB	0.83	---	---	---	---
2500(MHz)	0.9 9 dB	261. 00 deg	- 2.1 2 dB	327. 00 deg	---	3.10 dB	-0.29 dB	0.74	---	---	---	---

HP WLAN 2.4/5 GHz Trace Antenna Data Sheet – Stellar Module Ver 1.1

NF to FF transform Efficiency

Efficiency

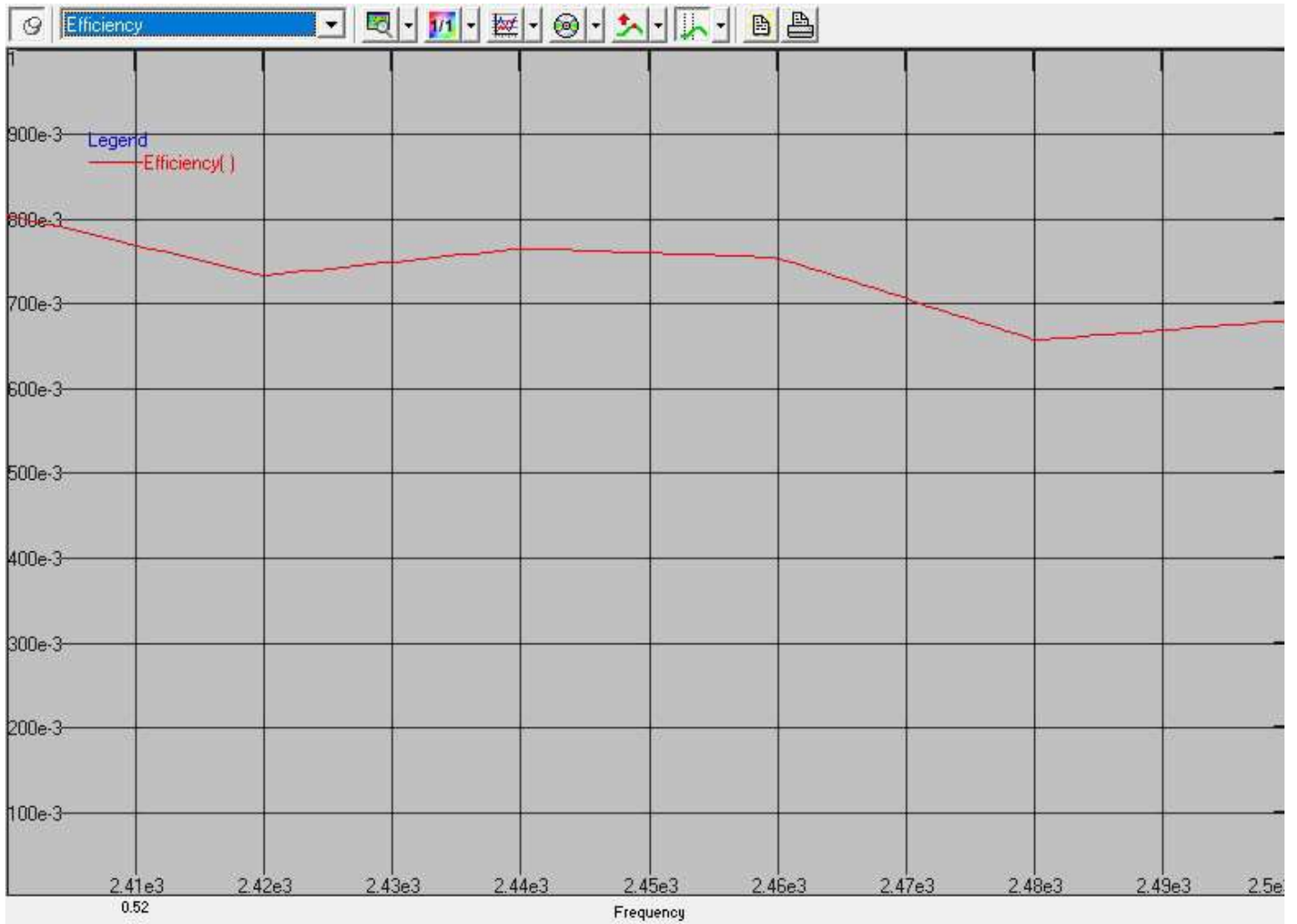

4) STELLAR Antenna 2 (AUX) 5.0-6.0 GHz

Phi=0.00deg

E Total. dB

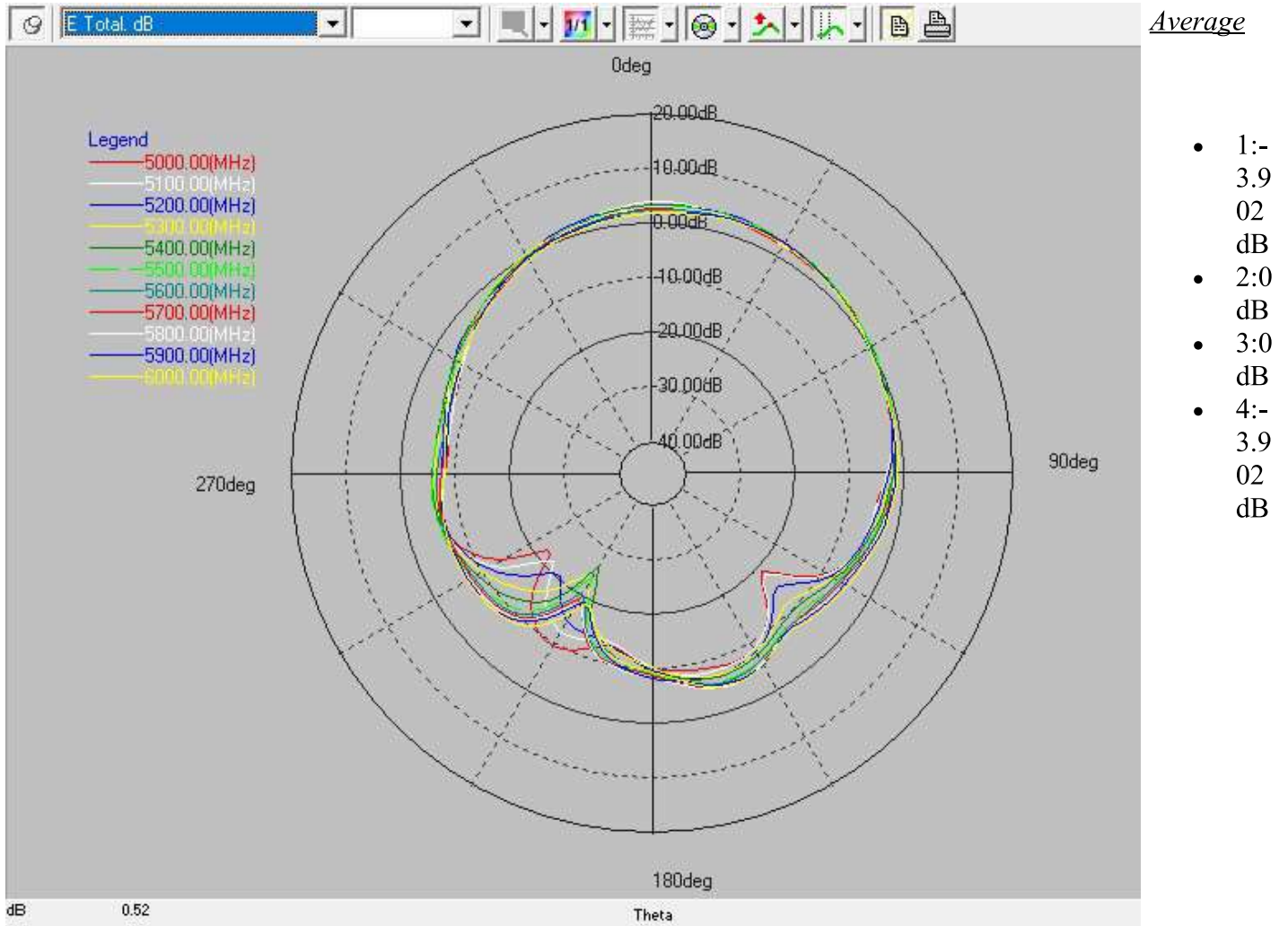

Layer	Max value	Position	Min value	Position	Beam Width	Max/Min	Average	Standard Deviation	Marker 1 pos	Marker 1 value	Marker 2 pos	Marker 2 value
5000(MHz)	3.04 dB	3.00 deg	-22.29 dB	-129.00 deg	81.69 deg	25.33 dB	-3.90 dB	6.08	---	---	---	---

HP WLAN 2.4/5 GHz Trace Antenna Data Sheet – Stellar Module Ver 1.1

5100(MHz)	3.7 2 dB	3.00 deg	- 21. 87 dB	- 132. 00 deg	75.85 deg	25.5 9 dB	-3.66 dB	6.35	---	---	---	---
5200(MHz)	3.3 5 dB	15.0 0 deg	- 20. 79 dB	- 138. 00 deg	86.62 deg	24.1 4 dB	-3.55 dB	6.17	---	---	---	---
5300(MHz)	2.9 7 dB	9.00 deg	- 23. 56 dB	- 147. 00 deg	96.70 deg	26.5 3 dB	-3.35 dB	6.33	---	---	---	---
5400(MHz)	3.2 3 dB	6.00 deg	- 26. 29 dB	- 150. 00 deg	87.68 deg	29.5 2 dB	-3.21 dB	6.02	---	---	---	---
5500(MHz)	3.1 2 dB	18.0 0 deg	- 23. 81 dB	- 150. 00 deg	92.16 deg	26.9 3 dB	-2.99 dB	5.52	---	---	---	---
5600(MHz)	2.7 7 dB	21.0 0 deg	- 20. 62 dB	- 150. 00 deg	93.43 deg	23.3 9 dB	-3.19 dB	5.04	---	---	---	---
5700(MHz)	2.8 4 dB	12.0 0 deg	- 19. 28 dB	- 150. 00 deg	89.52 deg	22.1 3 dB	-3.18 dB	4.92	---	---	---	---
5800(MHz)	2.8 7 dB	9.00 deg	- 18. 46 dB	- 150. 00 deg	86.74 deg	21.3 3 dB	-3.12 dB	4.83	---	---	---	---
5900(MHz)	2.7 9 dB	24.0 0 deg	- 19. 34 dB	- 153. 00 deg	88.36 deg	22.1 4 dB	-3.24 dB	4.87	---	---	---	---
6000(MHz)	2.3 8 dB	21.0 0 deg	- 19. 23 dB	- 153. 00 deg	93.38 deg	21.6 1 dB	-3.27 dB	4.79	---	---	---	---

HP WLAN 2.4/5 GHz Trace Antenna Data Sheet – Stellar Module Ver 1.1
 Phi=90.00deg

E Total. dB

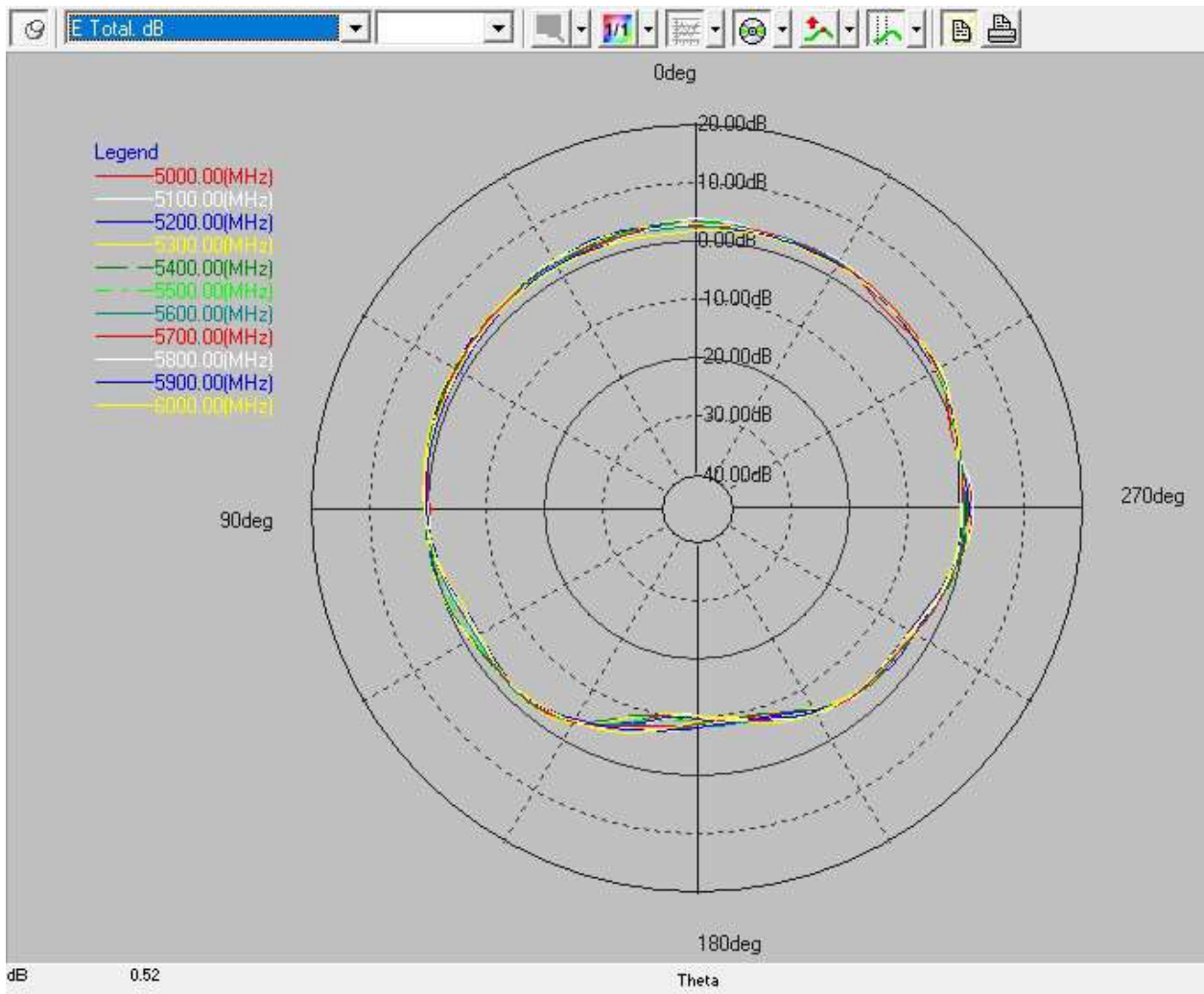

- 1:- 0.43 51 dB
- 2:0 dB
- 3:0 dB
- 4:- 0.43 51 dB

Layer	Max value	Position	Min value	Position	Beam Width	Max/Min	Average	Standard Deviation	Marker 1 pos	Marker 1 value	Marker 2 pos	Marker 2 value
5000(MHz)	3.11 dB	27.00 deg	-10.81 dB	177.00 deg	155.53 deg	13.92 dB	-0.44 dB	3.96	---	---	---	---
5100(MHz)	3.65 dB	0.00 deg	-10.70 dB	177.00 deg	153.68 deg	14.34 dB	-0.11 dB	3.96	---	---	---	---

HP WLAN 2.4/5 GHz Trace Antenna Data Sheet – Stellar Module Ver 1.1

5200(MHz)	3.2 0 dB	21.0 0 deg	- 10. 20 dB	177. 00 deg	164.10 deg	13.4 0 dB	-0.28 dB	3.89	---	---	---	---
5300(MHz)	3.0 4 dB	9.00 deg	- 10. 51 dB	177. 00 deg	183.41 deg	13.5 5 dB	-0.26 dB	4.13	---	---	---	---
5400(MHz)	3.1 3 dB	3.00 deg	- 9.9 7 dB	171. 00 deg	181.51 deg	13.1 0 dB	-0.31 dB	3.99	---	---	---	---
5500(MHz)	2.7 6 dB	6.00 deg	- 9.4 2 dB	174. 00 deg	184.62 deg	12.1 8 dB	-0.45 dB	3.70	---	---	---	---
5600(MHz)	2.7 7 dB	- 24.0 0 deg	- 8.5 5 dB	- 174. 00 deg	185.42 deg	11.3 2 dB	-0.49 dB	3.52	---	---	---	---
5700(MHz)	2.5 1 dB	-3.00 deg	- 9.1 4 dB	- 174. 00 deg	196.52 deg	11.6 6 dB	-0.54 dB	3.57	---	---	---	---
5800(MHz)	2.6 8 dB	-3.00 deg	- 9.1 7 dB	- 171. 00 deg	179.86 deg	11.8 5 dB	-0.69 dB	3.47	---	---	---	---
5900(MHz)	2.2 3 dB	- 21.0 0 deg	- 8.9 0 dB	- 171. 00 deg	184.31 deg	11.1 3 dB	-0.92 dB	3.38	---	---	---	---
6000(MHz)	1.9 5 dB	- 36.0 0 deg	- 9.9 4 dB	- 177. 00 deg	205.31 deg	11.9 0 dB	-0.87 dB	3.41	---	---	---	---

HP WLAN 2.4/5 GHz Trace Antenna Data Sheet – Stellar Module Ver 1.1

NF to FF transform Maximum Maximum

E Total. dB

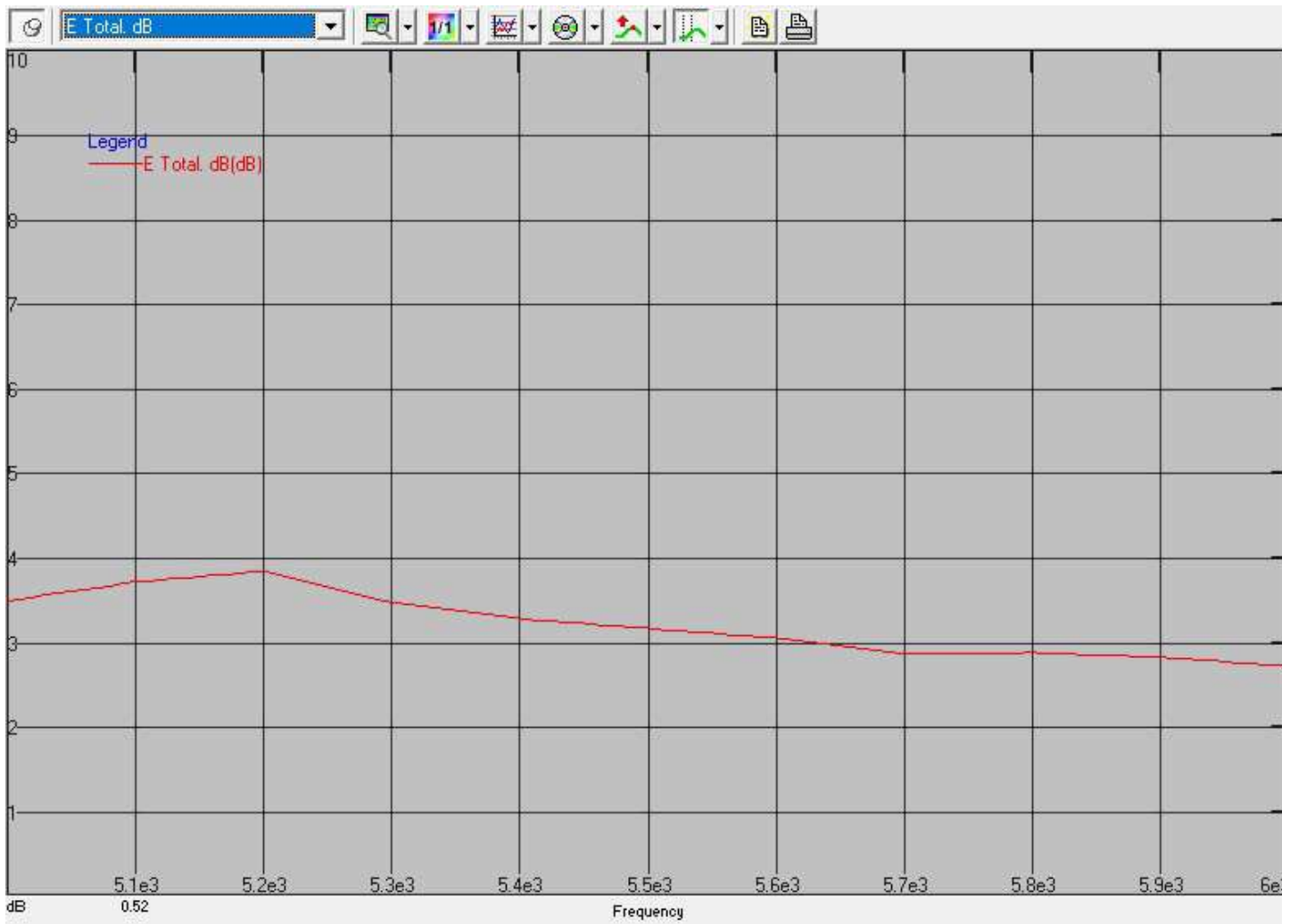

HP WLAN 2.4/5 GHz Trace Antenna Data Sheet – Stellar Module Ver 1.1
 Theta=90.00deg

E Total. dB

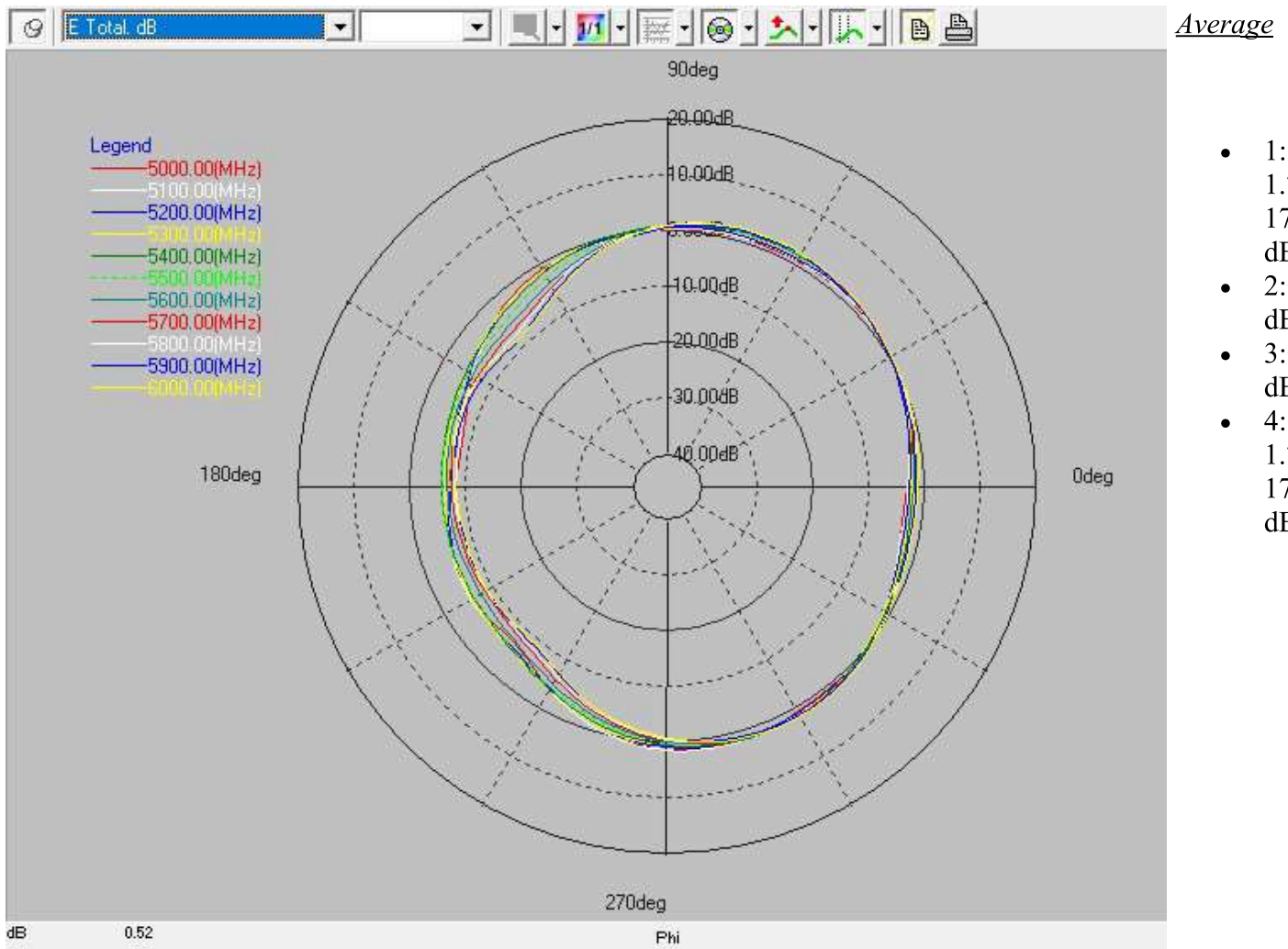

Layer	Max value	Position	Min value	Position	Beam Width	Max/Min	Average	Standard Deviation	Marker 1 pos	Marker 1 value	Marker 2 pos	Marker 2 value
5000(MHz)	1.55 dB	279.00 deg	-8.53 dB	171.00 deg	83.96 deg	10.07 dB	-1.72 dB	3.02	---	---	---	---
5100(MHz)	1.67 dB	279.00 deg	-8.30 dB	174.00 deg	81.09 deg	9.97 dB	-1.64 dB	2.95	---	---	---	---

HP WLAN 2.4/5 GHz Trace Antenna Data Sheet – Stellar Module Ver 1.1

5200(MHz)	1.19 dB	282.00 deg	-7.56 dB	174.00 deg	84.93 deg	8.75 dB	-1.64 dB	2.81	---	---	---	---
5300(MHz)	1.60 dB	60.00 deg	-6.13 dB	180.00 deg	109.49 deg	7.73 dB	-1.35 dB	2.65	---	---	---	---
5400(MHz)	1.65 dB	60.00 deg	-6.09 dB	213.00 deg	106.38 deg	7.74 dB	-1.32 dB	2.66	---	---	---	---
5500(MHz)	1.76 dB	60.00 deg	-6.17 dB	216.00 deg	100.50 deg	7.93 dB	-1.45 dB	2.76	---	---	---	---
5600(MHz)	1.83 dB	63.00 deg	-7.55 dB	213.00 deg	97.20 deg	9.38 dB	-1.72 dB	3.23	---	---	---	---
5700(MHz)	1.88 dB	63.00 deg	-8.58 dB	216.00 deg	93.26 deg	10.46 dB	-1.96 dB	3.64	---	---	---	---
5800(MHz)	2.06 dB	63.00 deg	-8.77 dB	216.00 deg	91.69 deg	10.82 dB	-2.02 dB	3.86	---	---	---	---
5900(MHz)	1.84 dB	63.00 deg	-9.05 dB	222.00 deg	93.63 deg	10.89 dB	-2.25 dB	3.99	---	---	---	---
6000(MHz)	2.18 dB	66.00 deg	-9.32 dB	225.00 deg	95.39 deg	11.50 dB	-2.02 dB	4.11	---	---	---	---

NF to FF transform Efficiency

Efficiency

HP WLAN 2.4/5 GHz Trace Antenna Data Sheet – Stellar Module Ver 1.1

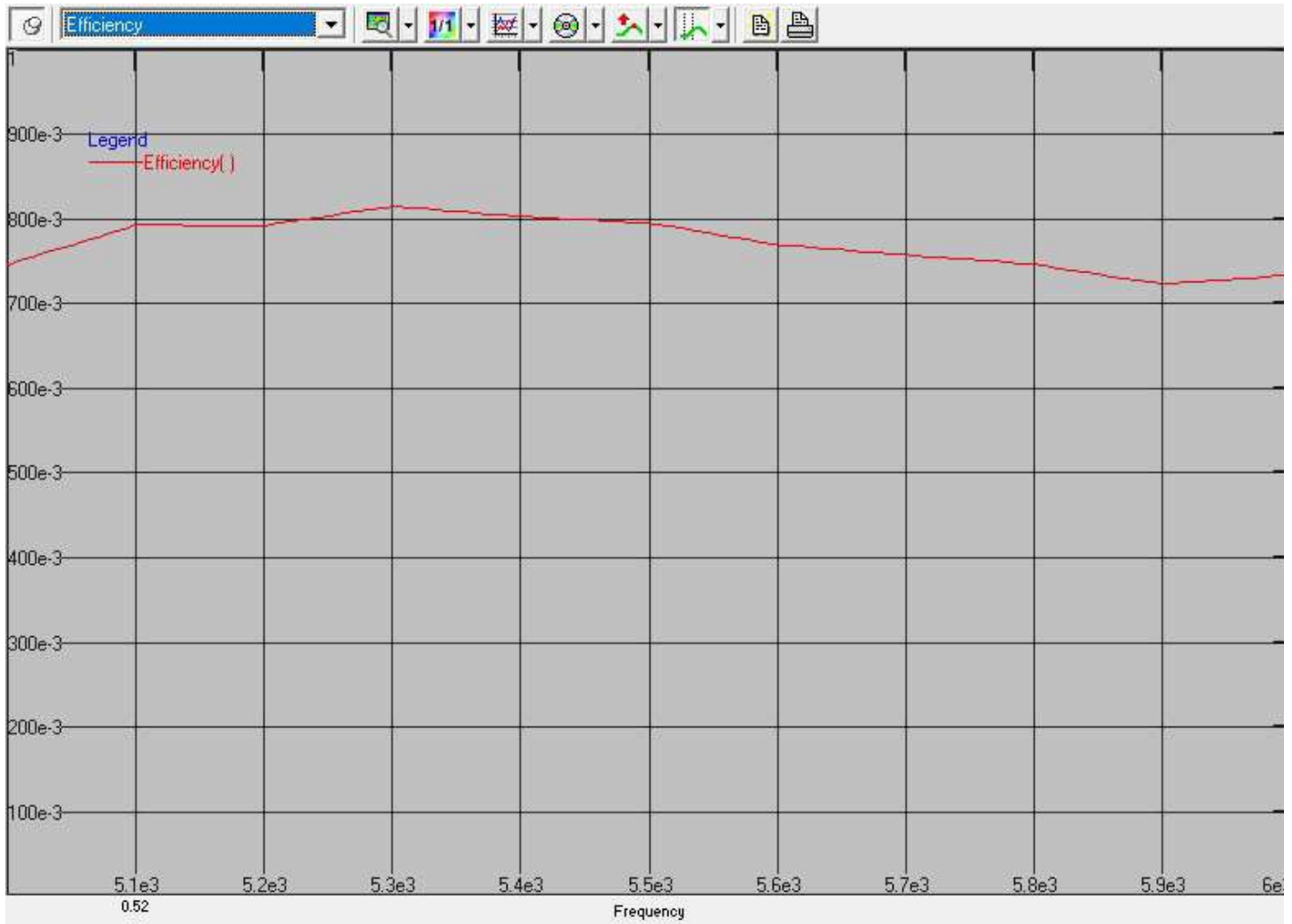

Generated by Star Gate. 10/19/2023 3:12:59 PM. with Satenv (c) [METRAWARE](#) & [SATIMO](#) 2001.
<mailto:info@metraware.com>

HP WLAN 2.4/5 GHz Trace Antenna Data Sheet – Stellar Module Ver 1.1

9) TEST SOFTWARE – Measurements completed using the proprietary Satenv

(c) [METRAWARE](#) & [SATIMO](#) Software

10) SATIMO SG-64 Chamber – Equipment Summary/calibration Sheet Below.

Introduction

This document summarizes the antenna gain measurements performed at MVG Inc. The purpose of this document is to provide a summary of the measurement procedure, traceability information, expanded uncertainties and the calibration data for the Antenna Under Test (AUT).

Measurement System Information

General Information

The antenna calibration is performed in a MVG SG-64 system with 63 probe antennas mounted with equal spacing on a circular arch. Electronic switching of the probe antennas provides outstanding measurement speed. The geometry of the setup, with only a Styrofoam column within 1.6 meters of the AUT, ensures minimum interference and low ripple on the measured radiation patterns.

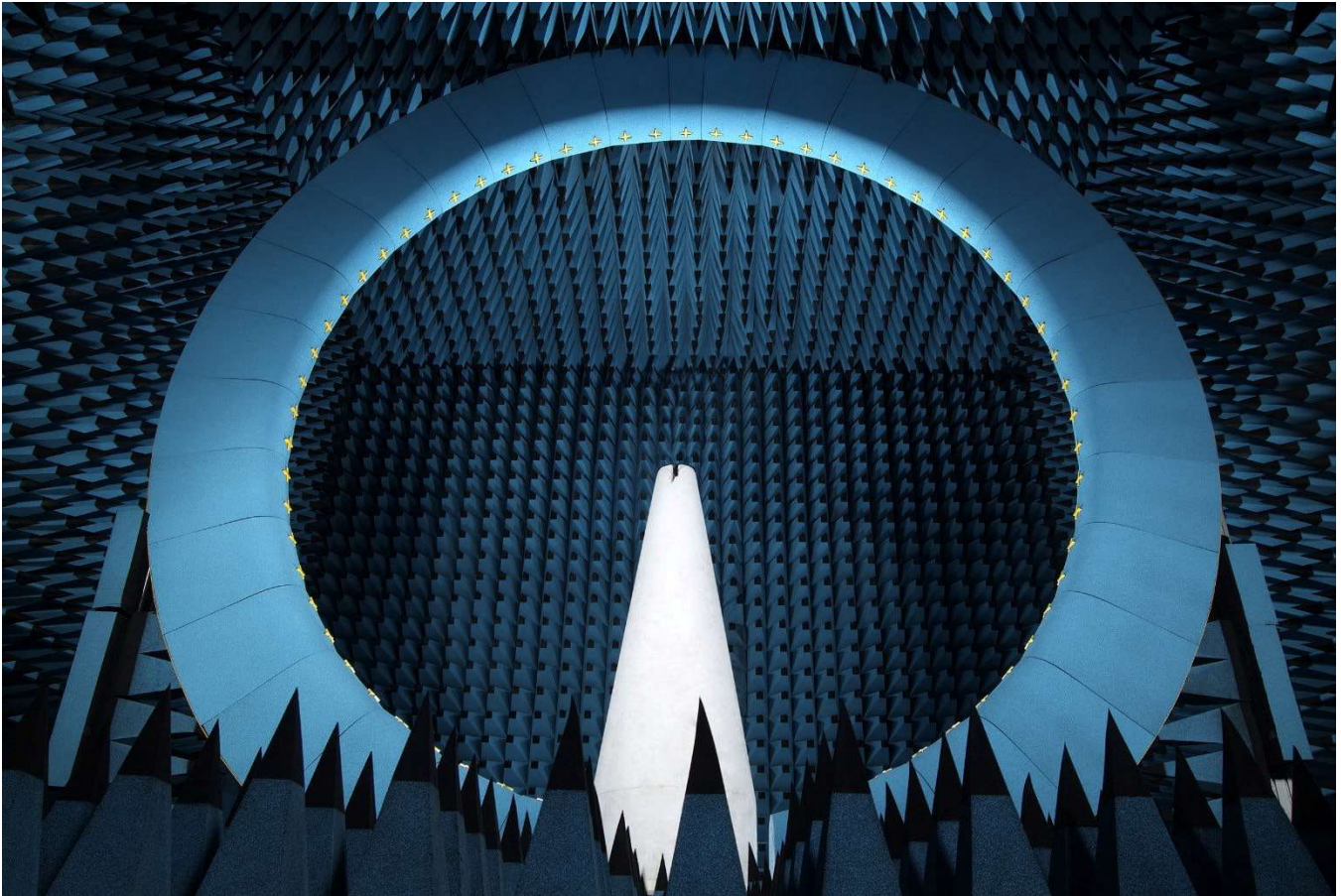

Figure 1 – *The SG-64. The AUT is placed on top of the pedestal, in the center of the system.*

List of Equipment

Equipment Summary Sheet				
Equipment Description	Manufacturer	Identification No.	Current Calibration Date	Next Calibration Date
SG-64 Probe Array	MVG	1102389-0006	12/2022	12/2023
RF Transmitter/ Receiver Unit (NPAC)	MVG	1102730-9110	characterized prior to test and in annual calibration	characterized prior to test and in annual calibration
Reference Horn Antenna	MVG	SH400 sn# 0017	08/2004	Verified in monthly checks. No cal required.
Reference Horn Antenna	MVG	SH800 sn# 0025	08/2004	Verified in monthly checks. No cal required.

Gain Calibration

Gain Definition

The reported boresight antenna **gain** is 4π times the ratio of the power radiated per unit solid angle in that direction to the net power delivered to the antenna by a 50Ω generator. This definition is also referred to as **realized antenna gain** which is less than the IEEE definition [IEEE Standard Test Procedures for Antennas, ANSI/IEEE Std 149-2021] by the value of the return loss.

Calibration Standard

The calibrated substitution antenna is a dual ridge horn as shown in Figure 2 below. This horn has been calibrated at NIST (Boulder, CO) which ensures direct traceability to a National Metrology Institute.

HP WLAN 2.4/5 GHz Trace Antenna Data Sheet – Stellar Module Ver 1.1

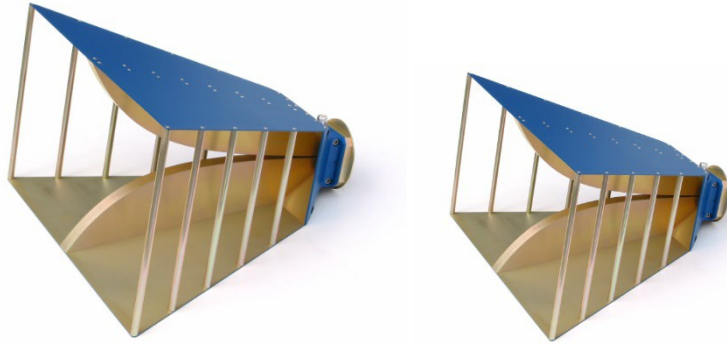

Figure 2 – MVG SH400-SN0017 and SH800-SN0025 horns.

Realized Boresight Gain of SH400-SN0017 from NIST

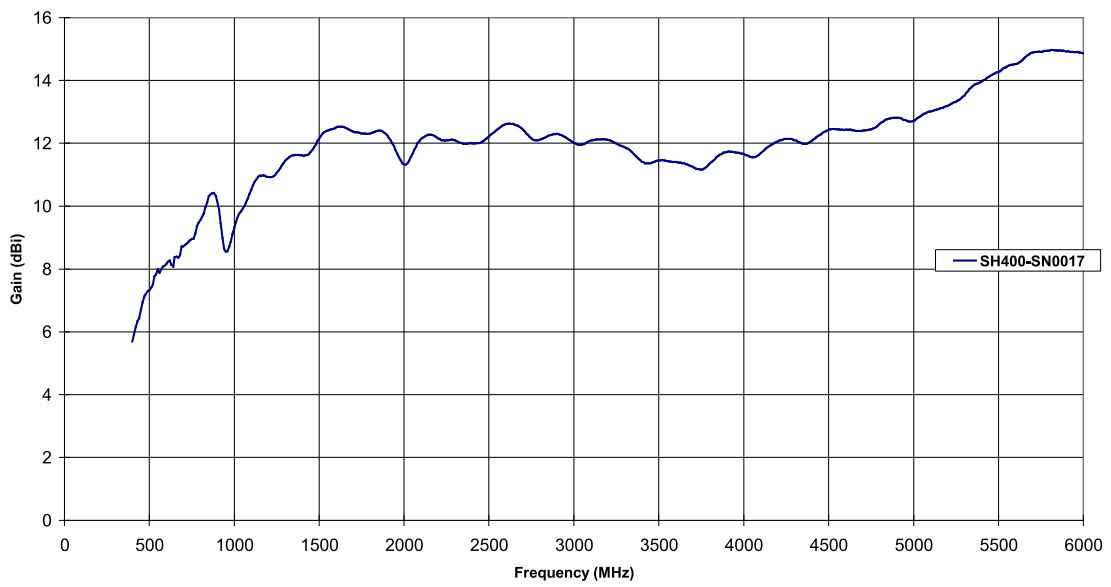

Figure 3 – NIST calibrated boresight gain vs. frequency plot of the MVG SH400-SN0017

HP WLAN 2.4/5 GHz Trace Antenna Data Sheet – Stellar Module Ver 1.1

Realized Boresight Gain vs. Frequency for SH800-SN0025 from NIST

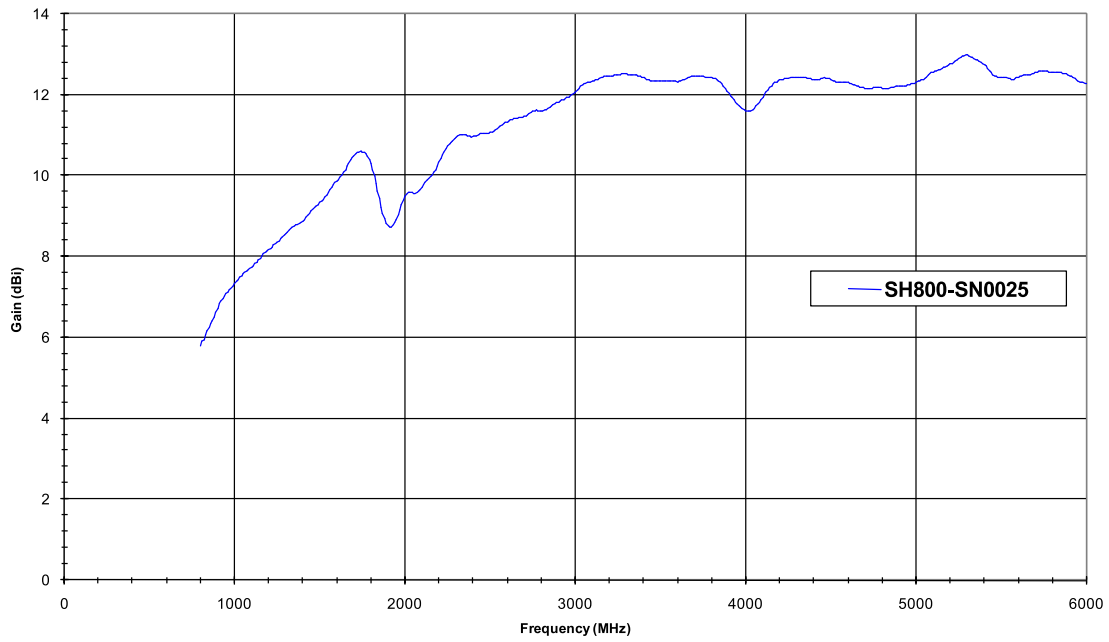

Figure 4 – NIST calibrated boresight gain vs. frequency plot of the MVG SH800-SN0025

Measurement Uncertainty

The following uncertainties apply to the gain measurement:

Frequency band	Expanded Uncertainty on Gain
400-800 MHz	0.89 dB
800-1000 MHz	0.84 dB
1000-6000 MHz	0.69 dB

HP WLAN 2.4/5 GHz Trace Antenna Data Sheet – Stellar Module Ver 1.1

These uncertainties represent an expanded uncertainty expressed at approximately the 95% confidence level using a coverage factor of $k=2$ traceable to the Internationally Accepted Guide to Measurement Uncertainty.

Measurement Setup

The AUT is mounted on a Styrofoam column as shown in the picture below.

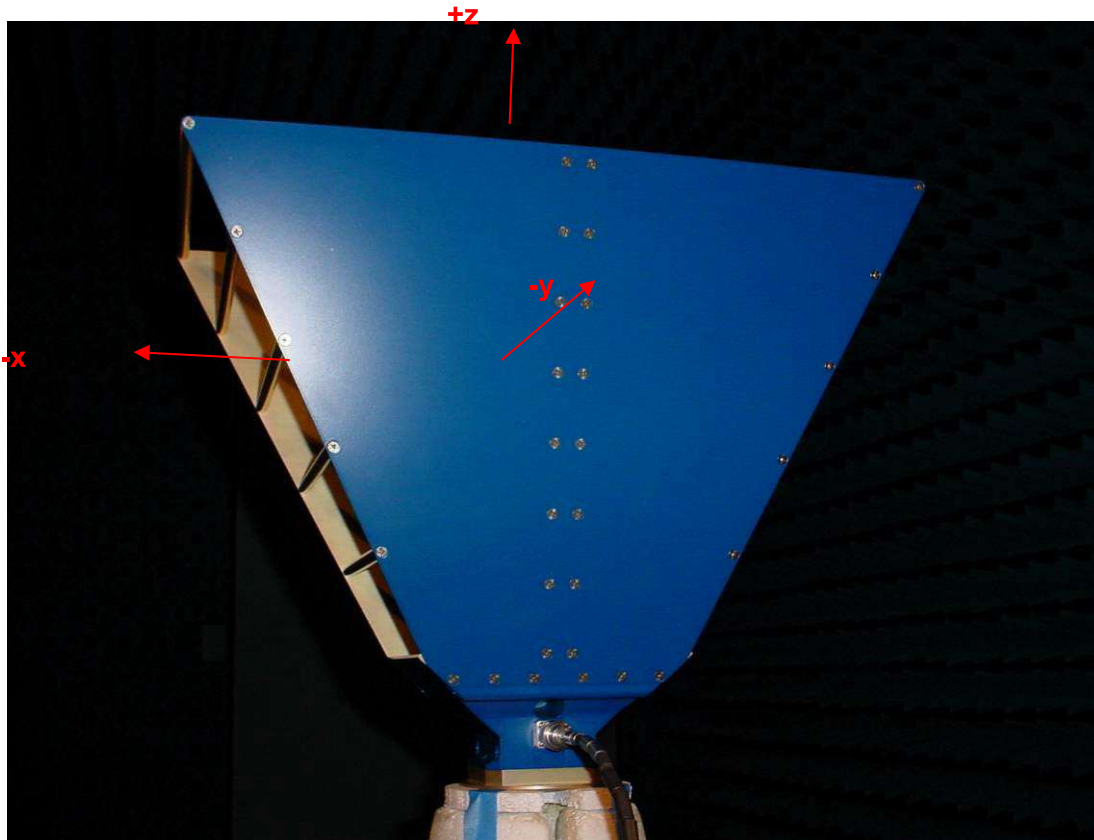

Figure 5 – Photograph illustrating an antenna mounted in the test range.

For clarity, a

coordinate system has been superimposed on the picture.

Coordinate System

The system coordinate system is shown in Figure 6.

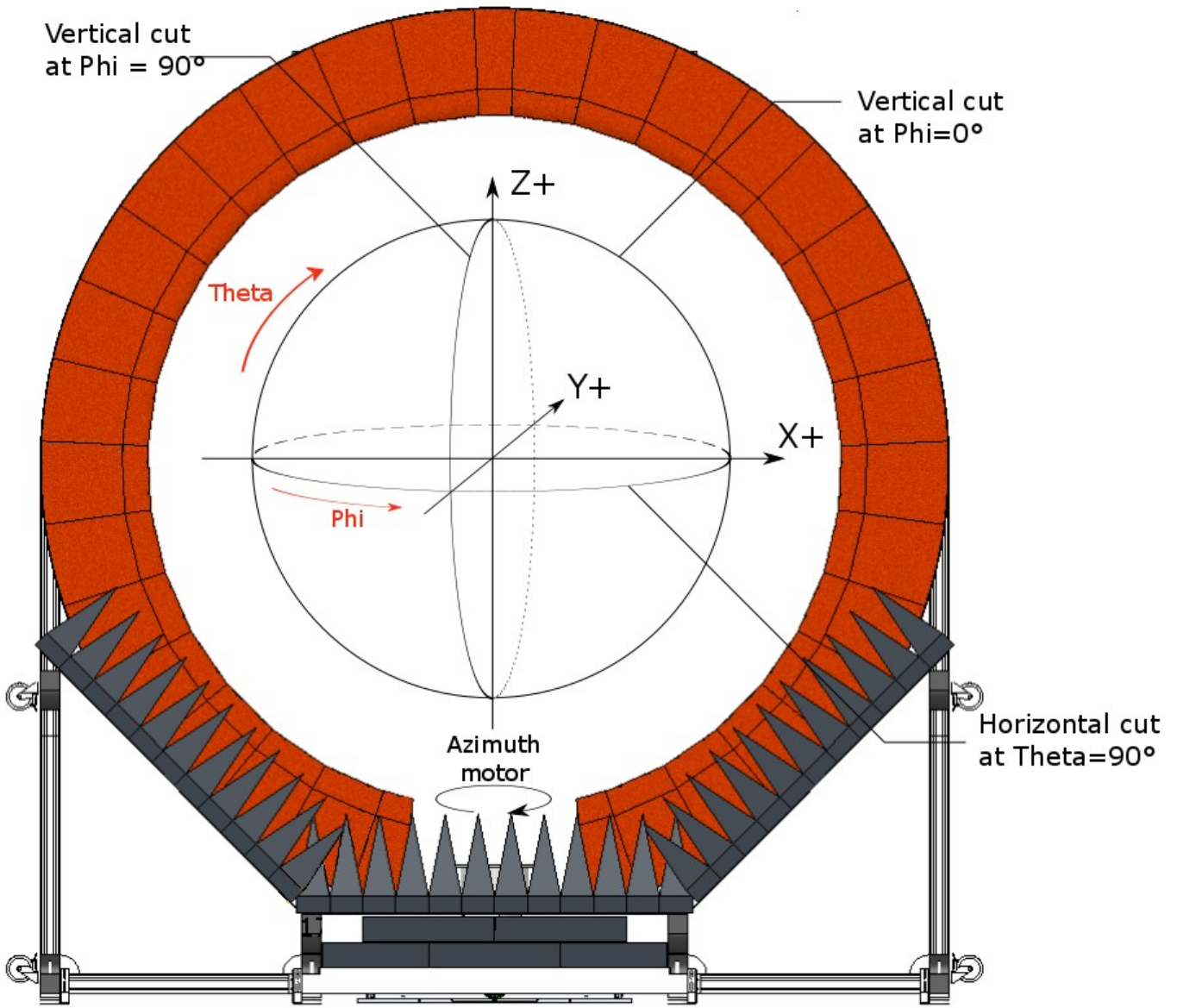

Figure 6: Coordinate System

CALIBRATION

DEPENDING ON THE FREQUENCY BAND, EITHER THE NIST CALIBRATED SH400-SN0017 OR SH800-SN0025 ANTENNA IS FIRST PLACED IN THE MEASUREMENT SYSTEM AS SHOWN IN FIGURE 5 AND, USING THE FREQUENCIES TABULATED IN THE RFQ, THE TEST ENGINEER MEASURES THE ANTENNA USING MVG'S PROPRIETARY WAVESTUDIO SOFTWARE. A NEAR-FIELD TO FAR-FIELD COMPUTATION IS PERFORMED USING SATENV, WHICH OUTPUTS THE BORESIGHT FAR-FIELD GAIN. THE SOFTWARE COMPARES THESE GAIN MEASUREMENTS, AS A FUNCTION OF FREQUENCY, TO THE COMPILED NIST MEASURED VALUES TO SERVE AS THE GAIN REFERENCE.

ANTENNA MEASUREMENT

The test engineer follows measures each customer antenna at the requested frequencies. SatEnv is then used to compute the far-field gain of the antenna using the reference data computed during the calibration process. Care is spent reviewing all details given in the RFQ to ensure data is output in the requested format.