

DATA SHEET

WIRELESS COMPONENTS

PCB type antenna
ANTX300P002B24553
2.40 ~ 2.50GHz / 5.150 ~ 5.875 GHz



FEATURES & BENEFITS

- The smallest PCB antenna in the market
- Miniature design allows users to save required space
- Double-side adhesive tape makes it easy to instal in device
- Ranges of types of connector and cable provide a flexible design options
- Halogen free and RoHS compliant

APPLICATIONS

- Tablet / Desktop PC
- Internet TV / STB / Game console / Camera
- WiFi network devices (IEEE 802.11b/g/n)
- Bluetooth / ZigBee devices
- Car Infotainment
- Smart meter
- Lighting control
- POS terminal
- Wireless Industrial Control

ORDERING INFORMATION - GLOBAL PART NUMBER, PHYCOMP

CTC & I2NC

All part numbers are identified by the series, packing type, material, size, antenna type, working frequency and packing quantity.

YAGEO BRAND ordering code

GLOBAL PART NUMBER (PREFERRED)

ANT X300 P 002 B 2455 3
(1) (2) (3) (4) (5) (6) (7)

(1) FAMILY

ANT = Antenna products

(2) CONNECTOR & CABLE LENGTH (MM)

X = I-PEX
300 = 300mm

(3) ANTENNA TYPE

P=PCB

(4) SERIAL NUMBER

002 = SERIAL NUMBER 002

(5) PACKAGE TYPE

B = Bulk

(6) WORKING FREQUENCY

2455 = 2.40 ~ 2.50 GHz / 5.150 ~ 5.875 GHz

(7) CABLE TYPE

3 = 1.13mm diameter Mini-Coaxial Cable

SPECIFICATIONS

Table 1

DESCRIPTION	VALUE
Working Frequency	2.40 ~ 2.50 GHz / 5.150 ~ 5.875 GHz
VSWR	2.5:1 max / 2.5:1 max
Peak Gain	0.9 dBi / 2.3 dBi
Polarization	Linear
Radiation Pattern	Omni-directional
Impedance	50 Ω Nominal
Operating Temperature	- 40 °C to 85 °C
Maximum Power	1 W
Dimension (PCB+AL Foil)	40mm x 43mm x 0.55mm
Radio Connector	I-PEX (20278-112R-13)
Cable Diameter / Length / Color	1.13mm / 300mm / Black
Mounting	Adhesive Tape (HF-DS)

DIMENSIONS

Table 2 Mechanical Dimension

DIMENSION	VALUE
L (mm)	300 ±3.00
W (mm)	40 ± 0.30
H (mm)	8 ± 0.30
H1 (mm)	32 ± 0.30
T (mm)	0.55 ± 0.15
A (mm)	2.30 Max
T1 (mm)	0.15 ± 0.05

OUTLINES

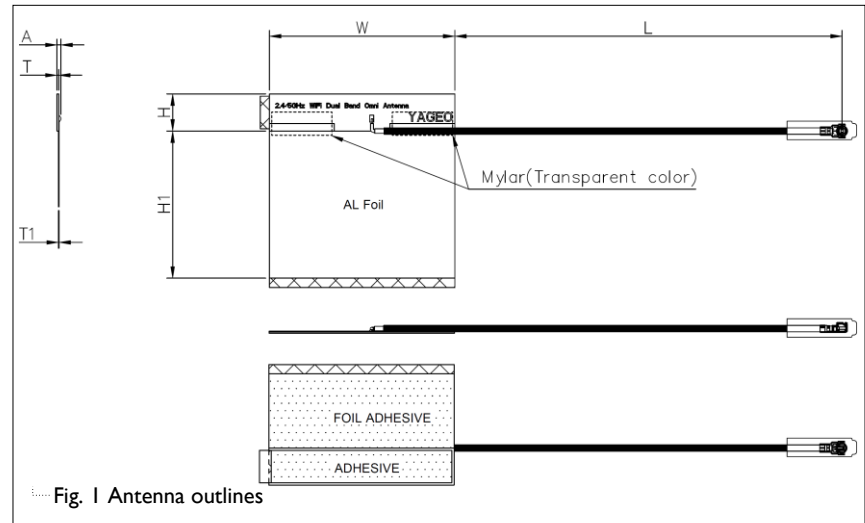

APPLICATION INSTRUCTION

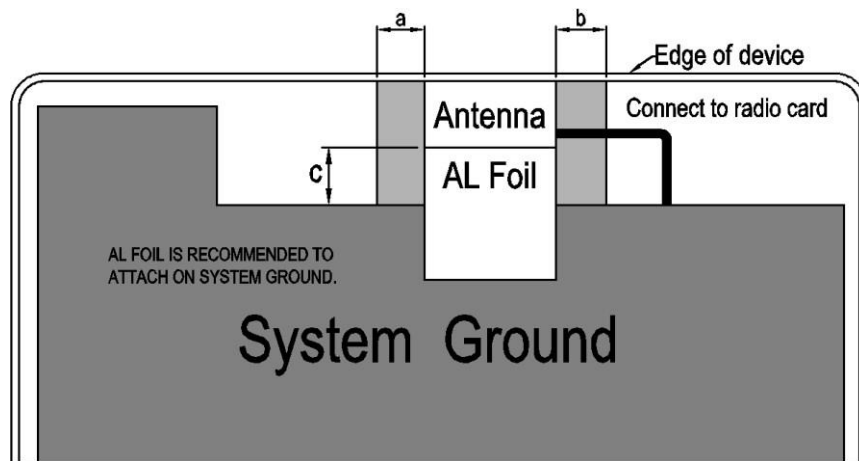

Antenna element should be placed at the edge of device, has minimum clearance from metallic object:

- A: 5 mm Min
- B: 5 mm Min
- C: 5 mm Max

Fig. 2 Application Instruction

RETURN LOSS & VSWR

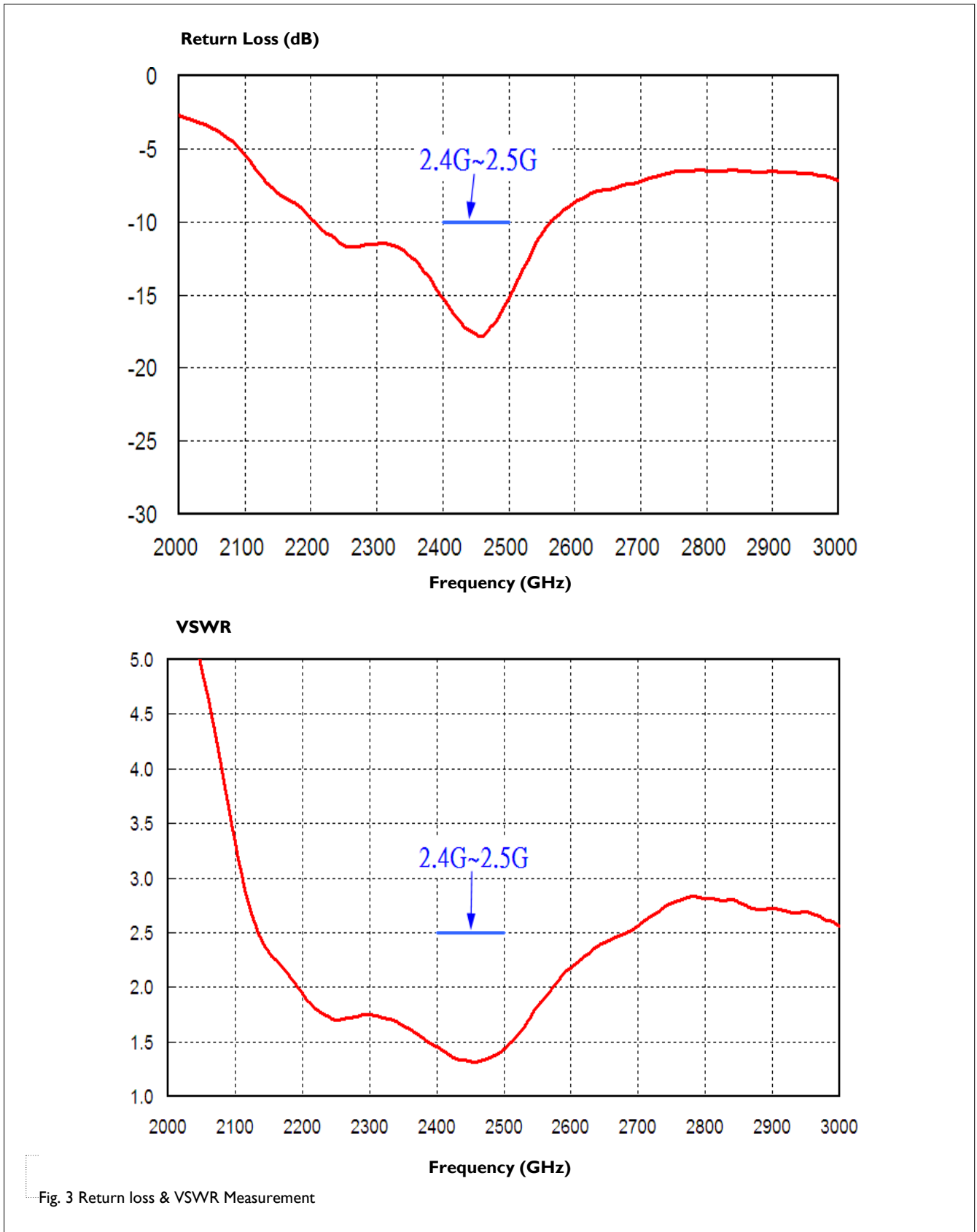

Fig. 3 Return loss & VSWR Measurement

ANTENNA GAIN & EFFICIENCY

Table 3

FREQUENCY (GHz)	AVERAGE GAIN (dBi)	EFFICIENCY (%)	PEAK GAIN (dBi)
2.40	-2.1	61.2	0.4
2.45	-1.7	68.2	0.7
2.50	-2.1	61.1	0.9

ANTENNA RADIATION PATTERNS

Scale: 5 dBi / div Max : 5 dBi Min : -25 dBi

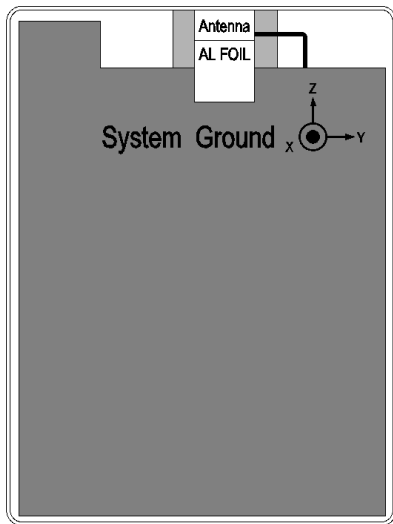

Device Setup & Coordinates

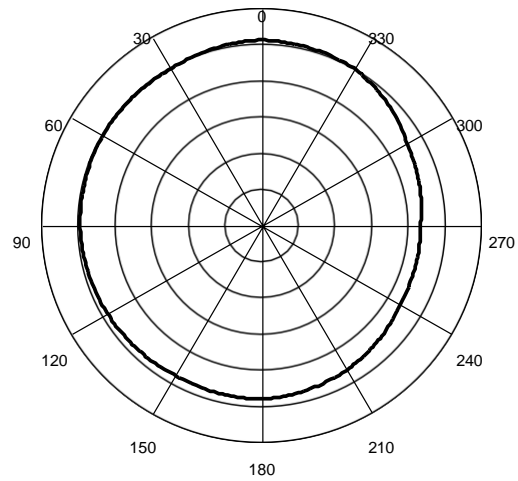

X-Y Plane

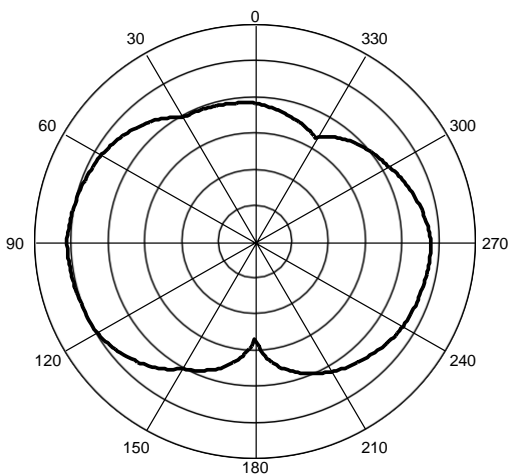

X-Z Plane

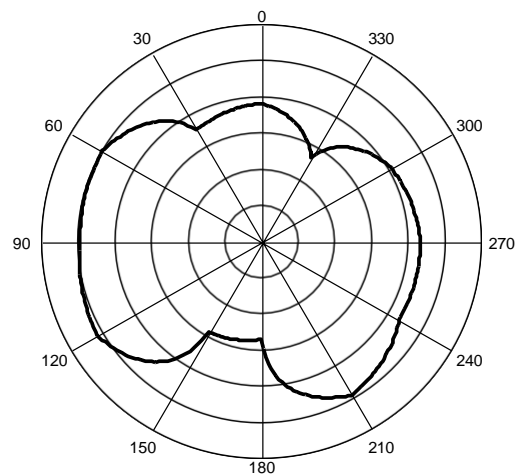

Y-Z Plane

Fig. 4 Antenna radiation patterns at 2.45 GHz

ANTENNA GAIN & EFFICIENCY

Table 4

FREQUENCY (GHz)	AVERAGE GAIN (dBi)	EFFICIENCY (%)	PEAK GAIN (dBi)
5.150	-3.9	41.0	2.3
5.350	-3.6	43.3	1.9
5.470	-4.4	40.4	1.0
5.725	-4.5	40.1	0.5
5.875	-4.1	40.9	0.4

ANTENNA RADIATION PATTERNS

Scale: 5 dBi / div Max : 5 dBi Min : -25 dBi

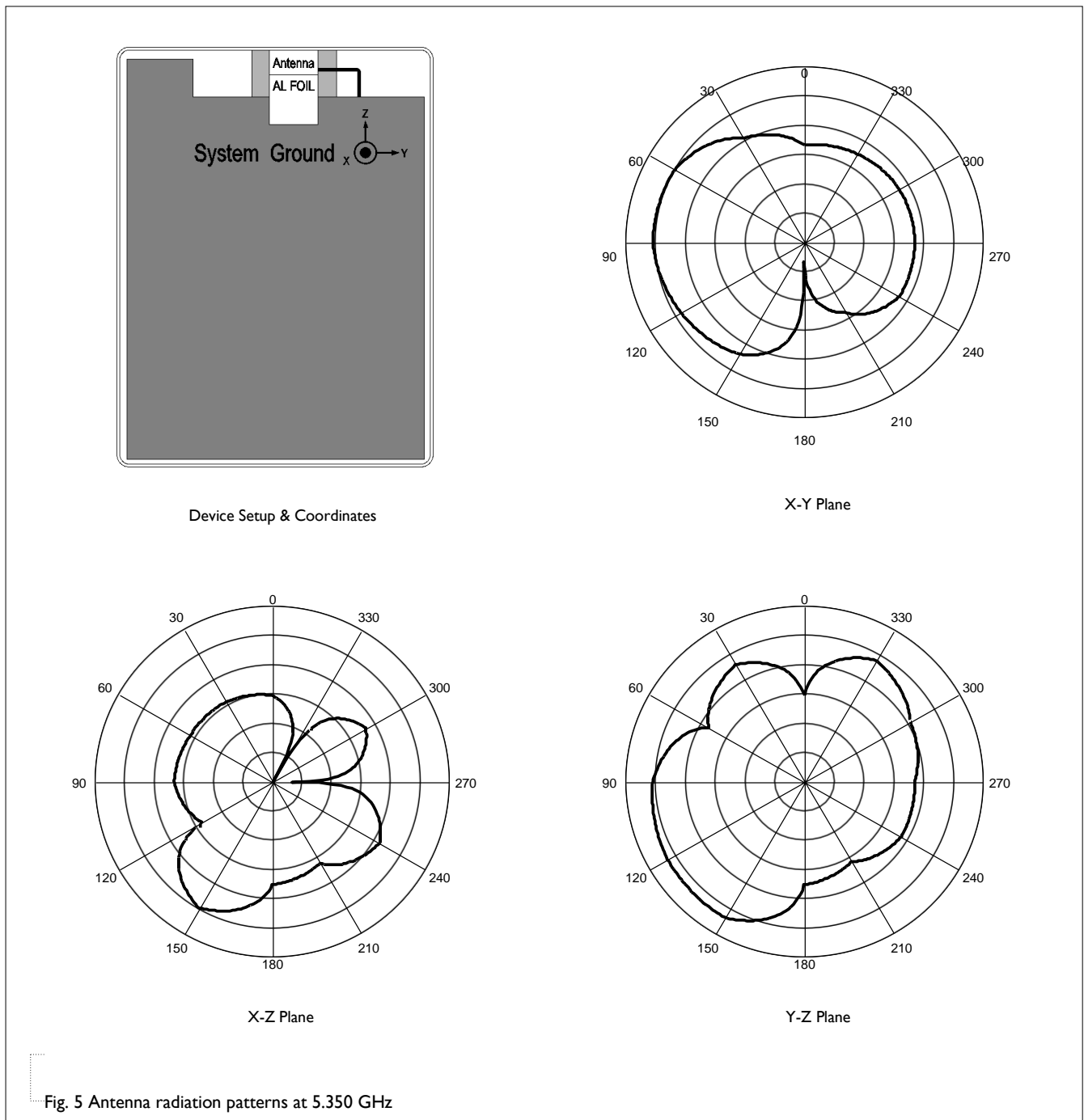

REVISION HISTORY

REVISION	DATE	CHANGE NOTIFICATION	DESCRIPTION
Version 0	Jun. 16, 2014	-	- New data sheet for PCB type antenna, 2.40 ~ 2.50GHz / 5.150 ~ 5.875 GHz
Version 1	Dec. 08, 2021		- Add mylar
Version 2	Mar. 08, 2024		- Correct the Peak Gain values