



# FCC TEST REPORT (15.247)

**REPORT NO.:** RF120614C11  
**MODEL NO.:** RSVLC-1103  
**FCC ID:** B94RSVLC1103  
**RECEIVED:** Jun. 14, 2012  
**TESTED:** Jun. 25 ~ Jul. 20, 2012  
**ISSUED:** Jul. 27, 2012

**APPLICANT:** Hewlett-Packard Company

**ADDRESS:** 8000 Foothills Blvd. Mail Stop 5603 Roseville,  
CA95747

**ISSUED BY:** Bureau Veritas Consumer Products Services  
(H.K.) Ltd., Taoyuan Branch

**LAB ADDRESS:** No. 47, 14th Ling, Chia Pau Vil., Lin Kou Dist.,  
New Taipei City, Taiwan, R.O.C.

**TEST LOCATION:** No. 19, Hwa Ya 2nd Rd, Wen Hwa Tsuen, Kwei  
Shan Hsiang, Taoyuan Hsien 333, Taiwan, R.O.C.

This report should not be used by the client to claim product certification, approval, or endorsement by TAF or any government agencies.



This report is for your exclusive use. Any copying or replication of this report to or for any other person or entity, or use of our name or trademark, is permitted only with our prior written permission. This report sets forth our findings solely with respect to the test samples identified herein. The results set forth in this report are not indicative or representative of the quality or characteristics of the lot from which a test sample was taken or any similar or identical product unless specifically and expressly noted. Our report includes all of the tests requested by you and the results thereof based upon the information that you provided to us. You have 60 days from date of issuance of this report to notify us of any material error or omission caused by our negligence, provided, however, that such notice shall be in writing and shall specifically address the issue you wish to raise. A failure to raise such issue within the prescribed time shall constitute your unqualified acceptance of the completeness of this report, the tests conducted and the correctness of the report contents. Unless specific mention, the uncertainty of measurement has been explicitly taken into account to declare the compliance or non-compliance to the specification.

# TABLE OF CONTENTS

RELEASE CONTROL RECORD.....	5
1. CERTIFICATION.....	6
2. SUMMARY OF TEST RESULTS .....	7
2.1 MEASUREMENT UNCERTAINTY.....	7
3. GENERAL INFORMATION.....	8
3.1 GENERAL DESCRIPTION OF EUT .....	8
3.2 DESCRIPTION OF TEST MODES .....	10
3.2.1 TEST MODE APPLICABILITY AND TESTED CHANNEL DETAIL .....	12
3.3 DESCRIPTION OF SUPPORT UNITS .....	16
3.3.1 CONFIGURATION OF SYSTEM UNDER TEST .....	16
3.4 GENERAL DESCRIPTION OF APPLIED STANDARDS .....	17
4. TEST TYPES AND RESULTS (FOR 2.4GHz BAND).....	18
4.1 RADIATED EMISSION AND BANDEGE MEASUREMENT.....	18
4.1.1 LIMITS OF RADIATED EMISSION AND BANDEGE MEASUREMENT .....	18
4.1.2 TEST INSTRUMENTS.....	19
4.1.3 TEST PROCEDURES .....	20
4.1.4 DEVIATION FROM TEST STANDARD.....	20
4.1.5 TEST SETUP.....	21
4.1.6 EUT OPERATING CONDITIONS .....	21
4.1.7 TEST RESULTS .....	22
4.2 CONDUCTED EMISSION MEASUREMENT .....	36
4.2.1 LIMITS OF CONDUCTED EMISSION MEASUREMENT .....	36
4.2.2 TEST INSTRUMENTS.....	36
4.2.3 TEST PROCEDURES .....	37
4.2.4 DEVIATION FROM TEST STANDARD.....	37
4.2.5 TEST SETUP.....	37
4.2.6 EUT OPERATING CONDITIONS .....	37
4.2.7 TEST RESULTS .....	38
4.3 6dB BANDWIDTH MEASUREMENT.....	42
4.3.1 LIMITS OF 6dB BANDWIDTH MEASUREMENT .....	42
4.3.2 TEST SETUP.....	42
4.3.3 TEST INSTRUMENTS.....	42
4.3.4 TEST PROCEDURE.....	42
4.3.5 DEVIATION FROM TEST STANDARD.....	42
4.3.6 EUT OPERATING CONDITIONS .....	42
4.3.7 TEST RESULTS .....	43
4.4 CONDUCTED OUTPUT POWER.....	44
4.4.1 LIMITS OF CONDUCTED OUTPUT POWER MEASUREMENT .....	44
4.4.2 TEST SETUP.....	44
4.4.3 TEST INSTRUMENTS.....	44
4.4.4 TEST PROCEDURES .....	44
4.4.5 DEVIATION FROM TEST STANDARD.....	44
4.4.6 EUT OPERATING CONDITIONS .....	44
4.4.7 TEST RESULTS .....	45
4.5 POWER SPECTRAL DENSITY MEASUREMENT.....	46
4.5.1 LIMITS OF POWER SPECTRAL DENSITY MEASUREMENT .....	46
4.5.2 TEST SETUP.....	46
4.5.3 TEST INSTRUMENTS.....	46



4.5.4	TEST PROCEDURE.....	46
4.5.5	DEVIATION FROM TEST STANDARD.....	46
4.5.6	EUT OPERATING CONDITION.....	46
4.5.7	TEST RESULTS .....	47
4.6	CONDUCTED OUT OF BAND EMISSION MEASUREMENT.....	48
4.6.1	LIMITS OF CONDUCTED OUT OF BAND EMISSION MEASUREMENT .....	48
4.6.2	TEST SETUP.....	48
4.6.3	TEST INSTRUMENTS.....	48
4.6.4	TEST PROCEDURE.....	48
4.6.5	DEVIATION FROM TEST STANDARD.....	49
4.6.6	EUT OPERATING CONDITION.....	49
4.6.7	TEST RESULTS .....	49
4.6.8	TEST RESULTS .....	50
5.	TEST TYPES AND RESULTS (FOR 5.0GHz BAND) .....	54
5.1	RADIATED EMISSION MEASUREMENT .....	54
5.1.1	LIMITS OF RADIATED EMISSION MEASUREMENT.....	54
5.1.2	TEST INSTRUMENTS.....	55
5.1.3	TEST PROCEDURES .....	55
5.1.4	DEVIATION FROM TEST STANDARD.....	55
5.1.5	TEST SETUP.....	55
5.1.6	EUT OPERATING CONDITIONS .....	55
5.1.7	TEST RESULTS .....	56
5.2	CONDUCTED EMISSION MEASUREMENT .....	66
5.2.1	LIMITS OF CONDUCTED EMISSION MEASUREMENT .....	66
5.2.2	TEST INSTRUMENTS.....	66
5.2.3	TEST PROCEDURES .....	66
5.2.4	DEVIATION FROM TEST STANDARD.....	66
5.2.5	TEST SETUP.....	66
5.2.6	EUT OPERATING CONDITIONS .....	66
5.2.7	TEST RESULTS .....	67
5.3	6dB BANDWIDTH MEASUREMENT.....	71
5.3.1	LIMITS OF 6dB BANDWIDTH MEASUREMENT .....	71
5.3.2	TEST SETUP.....	71
5.3.3	TEST INSTRUMENTS.....	71
5.3.4	TEST PROCEDURE.....	71
5.3.5	DEVIATION FROM TEST STANDARD.....	71
5.3.6	EUT OPERATING CONDITIONS .....	71
5.3.7	TEST RESULTS .....	72
5.4	CONDUCTED OUTPUT POWER.....	73
5.4.1	LIMITS OF CONDUCTED OUTPUT POWER MEASUREMENT .....	73
5.4.2	TEST SETUP.....	73
5.4.3	INSTRUMENTS.....	73
5.4.4	TEST PROCEDURES .....	73
5.4.5	DEVIATION FROM TEST STANDARD.....	73
5.4.6	EUT OPERATING CONDITIONS .....	73
5.4.7	TEST RESULTS .....	74
5.5	POWER SPECTRAL DENSITY MEASUREMENT .....	75
5.5.1	LIMITS OF POWER SPECTRAL DENSITY MEASUREMENT .....	75
5.5.2	TEST SETUP.....	75
5.5.3	TEST INSTRUMENTS.....	75
5.5.4	TEST PROCEDURE.....	75



A D T

5.5.5	DEVIATION FROM TEST STANDARD.....	75
5.5.6	EUT OPERATING CONDITION.....	75
5.5.7	TEST RESULTS .....	76
5.6	CONDUCTED OUT OF BAND EMISSION MEASUREMENT.....	77
5.6.1	LIMITS OF CONDUCTED OUT OF BAND EMISSION MEASUREMENT .....	77
5.6.2	TEST SETUP.....	77
5.6.3	TEST INSTRUMENTS.....	77
5.6.4	TEST PROCEDURE.....	77
5.6.5	DEVIATION FROM TEST STANDARD.....	77
5.6.6	EUT OPERATING CONDITION.....	77
5.6.7	TEST RESULTS .....	77
6.	PHOTOGRAPHS OF THE TEST CONFIGURATION.....	81
7.	INFORMATION ON THE TESTING LABORATORIES .....	82
8.	APPENDIX A - MODIFICATIONS RECORDERS FOR ENGINEERING CHANGES TO THE EUT BY THE LAB.....	83



A D T

## RELEASE CONTROL RECORD

ISSUE NO.	REASON FOR CHANGE	DATE ISSUED
RF120614C11	Original release	Jul. 27, 2012



## 1. CERTIFICATION

**PRODUCT:** HP M220 802.11n AM Access Point (refer to item 3.1 for more detail)  
**MODEL NO.:** RSVLC-1103  
**BRAND:** HP  
**APPLICANT:** Hewlett-Packard Company  
**TESTED:** Jun. 25 ~ Jul. 20, 2012  
**TEST SAMPLE:** ENGINEERING SAMPLE  
**STANDARDS:** **FCC Part 15, Subpart C (Section 15.247)**  
ANSI C63.10-2009

The above equipment (model: RSVLC-1103) has been tested by **Bureau Veritas Consumer Products Services (H.K.) Ltd., Taoyuan Branch**, and found compliance with the requirement of the above standards. The test record, data evaluation & Equipment Under Test (EUT) configurations represented herein are true and accurate accounts of the measurements of the sample's EMC characteristics under the conditions specified in this report.

PREPARED BY : Andrea Hsia , DATE : Jul. 27, 2012  
Andrea Hsia / Specialist

APPROVED BY : Gary Chang , DATE : Jul. 27, 2012  
Gary Chang / Technical Manager

## 2. SUMMARY OF TEST RESULTS

The EUT has been tested according to the following specifications:

APPLIED STANDARD: FCC PART 15, SUBPART C (SECTION 15.247)			
STANDARD SECTION	TEST TYPE	RESULT	REMARK
15.207	AC Power Conducted Emission	PASS	Meet the requirement of limit. Minimum passing margin is -8.63dB at 0.36484MHz.
15.247(d) 15.209	Radiated Emissions	PASS	Meet the requirement of limit. Minimum passing margin is -1.0dB at 2377.00, 2390.00 & 2483.50MHz.
15.247(d)	Band Edge Measurement	PASS	Meet the requirement of limit.
15.247(a)(2)	6dB bandwidth	PASS	Meet the requirement of limit.
15.247(b)	Conducted power	PASS	Meet the requirement of limit.
15.247(e)	Power Spectral Density	PASS	Meet the requirement of limit.
15.203	Antenna Requirement	PASS	Antenna connector is I-PEX not a standard connector.

### 2.1 MEASUREMENT UNCERTAINTY

Where relevant, the following measurement uncertainty levels have been estimated for tests performed on the EUT as specified in CISPR 16-4-2:

MEASUREMENT	FREQUENCY	UNCERTAINTY
Conducted emissions	9kHz~30MHz	2.44 dB
Radiated emissions	30MHz ~ 200MHz	3.34 dB
	200MHz ~1000MHz	3.35 dB
	1GHz ~ 18GHz	2.26 dB
	18GHz ~ 40GHz	1.94 dB

This uncertainty represents an expanded uncertainty expressed at approximately the 95% confidence level using a coverage factor of  $k = 2$ .

### 3. GENERAL INFORMATION

#### 3.1 GENERAL DESCRIPTION OF EUT

<b>EUT</b>	HP M220 802.11n AM Access Point (refer to note as below)
<b>MODEL NO.</b>	RSVLC-1103
<b>POWER SUPPLY</b>	12Vdc (Adapter) 48Vdc (POE)
<b>MODULATION TYPE</b>	CCK, DQPSK, DBPSK for DSSS 64QAM, 16QAM, QPSK, BPSK for OFDM
<b>MODULATION TECHNOLOGY</b>	DSSS, OFDM
<b>TRANSFER RATE</b>	802.11b: 11.0/ 5.5/ 2.0/ 1.0Mbps 802.11g: 54.0/ 48.0/ 36.0/ 24.0/ 18.0/ 12.0/ 9.0/ 6.0Mbps 802.11a: 54.0/ 48.0/ 36.0/ 24.0/ 18.0/ 12.0/ 9.0/ 6.0Mbps 802.11n: up to 300.0Mbps
<b>OPERATING FREQUENCY</b>	<b>2.4GHz:</b> 2412 ~ 2462MHz <b>5.0GHz:</b> 5745 ~ 5825MHz
<b>NUMBER OF CHANNEL</b>	<b>2.4GHz:</b> 11 for 802.11b, 802.11g, 802.11n (20MHz) 7 for 802.11n (40MHz) <b>5.0GHz:</b> 5 for 802.11a, 802.11n (20MHz) 2 for 802.11n (40MHz)
<b>OUTPUT POWER</b>	512.3mW for 2412 ~ 2462MHz 314.1mW for 5745 ~ 5825MHz
<b>ANTENNA TYPE</b>	<b>2.4GHz:</b> PCB antenna with 4dBi gain <b>5.0GHz:</b> PCB antenna with 5dBi gain
<b>ANTENNA CONNECTOR</b>	I-PEX
<b>DATA CABLE</b>	NA
<b>I/O PORTS</b>	Refer to user's manual
<b>ACCESSORY DEVICES</b>	Adapter

#### NOTE:

- The product names as below are identical to each other except for their model designation and brand name due to marketing purpose.

Brand	Model	Product name
HP	RSVLC-1103	HP M220 802.11n AM Access Point
		HP M220 802.11n WW Access Point

- The EUT incorporates a MIMO function. Physically, the EUT provides two completed transmitters and three receivers.

MODULATION MODE	TX FUNCTION
802.11b	1TX
802.11g	2TX
802.11a	2TX
802.11n (20MHz)	2TX
802.11n (40MHz)	2TX



3. The EUT were powered by the following adapter & POE:

<b>ADAPTER</b>	
<b>BRAND:</b>	DELTA ELECTRONICS, INC.
<b>MODEL:</b>	EADP-15DC A
<b>INPUT:</b>	100-240Vac, 0.4A, 50/60Hz LPS
<b>OUTPUT:</b>	12Vdc, 1.25A
<b>POWER LINE:</b>	1.8m non-shielded cable without core

<b>POE</b>	
<b>BRAND:</b>	PowerDsine
<b>MODEL:</b>	PD-3501G/AC
<b>INPUT:</b>	100-240Vac, 0.5A, 50/60Hz
<b>OUTPUT:</b>	48Vdc, 0.35A
<b>POWER LINE:</b>	1.9m non-shielded cable without core

\* POE is provided as support units only.

4. The EUT had been pre-tested on the positioned of each 3 modes. The worst case was found when positioned on mode 2

<b>TEST MODE</b>	<b>POSITIONED</b>
<b>MODE 1</b>	Horizontal (desk top) mounting
<b>MODE 2</b>	Vertical (wall) mounting
<b>MODE 3</b>	Inverted horizontal (ceiling) mounting

5. The above EUT information is declared by manufacturer and for more detailed features description, please refer to the manufacturer's specifications or user's manual.

### 3.2 DESCRIPTION OF TEST MODES

#### FOR 2.4GHz:

11 channels are provided for 802.11b, 802.11g and 802.11n (20MHz):

CHANNEL	FREQUENCY	CHANNEL	FREQUENCY
1	2412MHz	7	2442MHz
2	2417MHz	8	2447MHz
3	2422MHz	9	2452MHz
4	2427MHz	10	2457MHz
5	2432MHz	11	2462MHz
6	2437MHz		

7 channels are provided for 802.11n (40MHz):

CHANNEL	FREQUENCY	CHANNEL	FREQUENCY
3	2422MHz	7	2442MHz
4	2427MHz	8	2447MHz
5	2432MHz	9	2452MHz
6	2437MHz		

#### FOR 5.0GHz (5745 ~ 5825MHz):

5 channels are provided for 802.11a, 802.11n (20MHz):

CHANNEL	FREQUENCY	CHANNEL	FREQUENCY
149	5745MHz	161	5805MHz
153	5765MHz	165	5825MHz
157	5785MHz		

2 channels are provided for 802.11n (40MHz):

CHANNEL	FREQUENCY	CHANNEL	FREQUENCY
151	5755MHz	159	5795MHz



### POWER SETTING

802.11b		802.11g	
CHANNEL	POWER SETTING (txpwr1 -o -q)	CHANNEL	POWER SETTING (txpwr1 -o -q)
1	67	1	55
6	67	6	66
11	67	11	55

802.11n (20MHz)		802.11n (40MHz)	
CHANNEL	POWER SETTING (txpwr1 -o -q)	CHANNEL	POWER SETTING (txpwr1 -o -q)
1	50	3	34
6	66	6	50
11	50	9	33

802.11a		802.11n (20MHz)	
CHANNEL	POWER SETTING (txpwr1 -o -q)	CHANNEL	POWER SETTING (txpwr1 -o -q)
149	56	149	54
157	54	157	54
165	54	165	54

802.11n (40MHz)	
CHANNEL	POWER SETTING (txpwr1 -o -q)
151	58
159	58

### 3.2.1 TEST MODE APPLICABILITY AND TESTED CHANNEL DETAIL

#### FOR 2.4GHz:

EUT CONFIGURE MODE	APPLICABLE TO				DESCRIPTION
	RE $\geq$ 1G	RE<1G	PLC	APCM	
A	√	√	√	√	Power from Adapter
B	-	√	√	-	Power from POE

Where **RE $\geq$ 1G**: Radiated Emission above 1GHz      **RE<1G**: Radiated Emission below 1GHz  
**PLC**: Power Line Conducted Emission      **APCM**: Antenna Port Conducted Measurement  
**NOTE**: "-" means no effect.

**NOTE**: The EUT had been pre-tested on the positioned of each 3 axis. The worst case was found when positioned on **Z-plane (Vertical (wall) mounting)**.

#### RADIATED EMISSION TEST (ABOVE 1GHz):

- Pre-Scan has been conducted to determine the worst-case mode from all possible combinations between available modulations, data rates and antenna ports (if EUT with antenna diversity architecture).
- Following channel(s) was (were) selected for the final test as listed below.

EUT CONFIGURE MODE	MODE	AVAILABLE CHANNEL	TESTED CHANNEL	MODULATION TECHNOLOGY	MODULATION TYPE	DATA RATE (Mbps)
A	802.11b	1 to 11	1, 6, 11	DSSS	DBPSK	1.0
A	802.11g	1 to 11	1, 6, 11	OFDM	BPSK	6.0
A	802.11n (20MHz)	1 to 11	1, 6, 11	OFDM	BPSK	7.2
A	802.11n (40MHz)	3 to 9	3, 6, 9	OFDM	BPSK	15.0

#### RADIATED EMISSION TEST (BELOW 1GHz):

- Pre-Scan has been conducted to determine the worst-case mode from all possible combinations between available modulations, data rates and antenna ports (if EUT with antenna diversity architecture).
- Following channel(s) was (were) selected for the final test as listed below.

EUT CONFIGURE MODE	MODE	AVAILABLE CHANNEL	TESTED CHANNEL	MODULATION TECHNOLOGY	MODULATION TYPE	DATA RATE (Mbps)
A & B	802.11n (20MHz)	1 to 11	6	OFDM	BPSK	7.2

#### POWER LINE CONDUCTED EMISSION TEST:

- Pre-Scan has been conducted to determine the worst-case mode from all possible combinations between available modulations, data rates and antenna ports (if EUT with antenna diversity architecture).
- Following channel(s) was (were) selected for the final test as listed below.

EUT CONFIGURE MODE	MODE	AVAILABLE CHANNEL	TESTED CHANNEL	MODULATION TECHNOLOGY	MODULATION TYPE	DATA RATE (Mbps)
A & B	802.11n (20MHz)	1 to 11	6	OFDM	BPSK	7.2

**BANDEDGE MEASUREMENT:**

- Pre-Scan has been conducted to determine the worst-case mode from all possible combinations between available modulations, data rates and antenna ports (if EUT with antenna diversity architecture).
- Following channel(s) was (were) selected for the final test as listed below.

EUT CONFIGURE MODE	MODE	AVAILABLE CHANNEL	TESTED CHANNEL	MODULATION TECHNOLOGY	MODULATION TYPE	DATA RATE (Mbps)
A	802.11b	1 to 11	1, 11	DSSS	DBPSK	1.0
A	802.11g	1 to 11	1, 11	OFDM	BPSK	6.0
A	802.11n (20MHz)	1 to 11	1, 11	OFDM	BPSK	7.2
A	802.11n (40MHz)	3 to 9	3, 9	OFDM	BPSK	15.0

**ANTENNA PORT CONDUCTED MEASUREMENT:**

- This item includes all test value of each mode, but only includes spectrum plot of worst value of each mode.
- Pre-Scan has been conducted to determine the worst-case mode from all possible combinations between available modulations, data rates and antenna ports (if EUT with antenna diversity architecture).
- Following channel(s) was (were) selected for the final test as listed below.

EUT CONFIGURE MODE	MODE	AVAILABLE CHANNEL	TESTED CHANNEL	MODULATION TECHNOLOGY	MODULATION TYPE	DATA RATE (Mbps)
A	802.11b	1 to 11	1, 6, 11	DSSS	DBPSK	1.0
A	802.11g	1 to 11	1, 6, 11	OFDM	BPSK	6.0
A	802.11n (20MHz)	1 to 11	1, 6, 11	OFDM	BPSK	7.2
A	802.11n (40MHz)	3 to 9	3, 6, 9	OFDM	BPSK	15.0

**TEST CONDITION:**

APPLICABLE TO	ENVIRONMENTAL CONDITIONS	INPUT POWER	TESTED BY
RE $\geq$ 1G	23deg. C, 67%RH	120Vac, 60Hz	Sun Lin
RE $<$ 1G	22deg. C, 70%RH 25deg. C, 68%RH	120Vac, 60Hz 48Vdc	Sun Lin
PLC	23deg. C, 53%RH	120Vac, 60Hz 48Vdc	Skys Huang
APCM	22deg. C, 70%RH	120Vac, 60Hz	Sun Lin

**FOR 5.0GHz (5745 ~ 5825MHz):**

EUT CONFIGURE MODE	APPLICABLE TO				DESCRIPTION
	RE≥1G	RE<1G	PLC	APCM	
A	√	√	√	√	Power from Adapter
B	-	√	√	-	Power from POE

Where **RE≥1G**: Radiated Emission above 1GHz      **RE<1G**: Radiated Emission below 1GHz  
**PLC**: Power Line Conducted Emission      **APCM**: Antenna Port Conducted Measurement  
**NOTE**: "-" means no effect.

**NOTE**: The EUT had been pre-tested on the positioned of each 3 axis. The worst case was found when positioned on **Z-plane (Vertical (wall) mounting)**.

**RADIATED EMISSION TEST (ABOVE 1GHz):**

- Pre-Scan has been conducted to determine the worst-case mode from all possible combinations between available modulations, data rates and antenna ports (if EUT with antenna diversity architecture).
- Following channel(s) was (were) selected for the final test as listed below.

EUT CONFIGURE MODE	MODE	AVAILABLE CHANNEL	TESTED CHANNEL	MODULATION TECHNOLOGY	MODULATION TYPE	DATA RATE (Mbps)
A	802.11a	149 to 165	149, 157, 165	OFDM	BPSK	6.0
A	802.11n (20MHz)	149 to 165	149, 157, 165	OFDM	BPSK	7.2
A	802.11n (40MHz)	151 to 159	151, 159	OFDM	BPSK	15.0

**RADIATED EMISSION TEST (BELOW 1GHz):**

- Pre-Scan has been conducted to determine the worst-case mode from all possible combinations between available modulations, data rates and antenna ports (if EUT with antenna diversity architecture).
- Following channel(s) was (were) selected for the final test as listed below.

EUT CONFIGURE MODE	MODE	AVAILABLE CHANNEL	TESTED CHANNEL	MODULATION TECHNOLOGY	MODULATION TYPE	DATA RATE (Mbps)
A & B	802.11a	149 to 165	149	OFDM	BPSK	6.0

**POWER LINE CONDUCTED EMISSION TEST:**

- Pre-Scan has been conducted to determine the worst-case mode from all possible combinations between available modulations, data rates and antenna ports (if EUT with antenna diversity architecture).
- Following channel(s) was (were) selected for the final test as listed below.

EUT CONFIGURE MODE	MODE	AVAILABLE CHANNEL	TESTED CHANNEL	MODULATION TECHNOLOGY	MODULATION TYPE	DATA RATE (Mbps)
A & B	802.11a	149 to 165	149	OFDM	BPSK	6.0

**BANDEDGE MEASUREMENT:**

- Pre-Scan has been conducted to determine the worst-case mode from all possible combinations between available modulations, data rates and antenna ports (if EUT with antenna diversity architecture).
- Following channel(s) was (were) selected for the final test as listed below.

EUT CONFIGURE MODE	MODE	AVAILABLE CHANNEL	TESTED CHANNEL	MODULATION TECHNOLOGY	MODULATION TYPE	DATA RATE (Mbps)
A	802.11a	149 to 165	149, 165	OFDM	BPSK	6.0
A	802.11n (20MHz)	149 to 165	149, 165	OFDM	BPSK	7.2
A	802.11n (40MHz)	151 to 159	151, 159	OFDM	BPSK	15.0

**ANTENNA PORT CONDUCTED MEASUREMENT:**

- This item includes all test value of each mode, but only includes spectrum plot of worst value of each mode.
- Pre-Scan has been conducted to determine the worst-case mode from all possible combinations between available modulations, data rates and antenna ports (if EUT with antenna diversity architecture).
- Following channel(s) was (were) selected for the final test as listed below.

EUT CONFIGURE MODE	MODE	AVAILABLE CHANNEL	TESTED CHANNEL	MODULATION TECHNOLOGY	MODULATION TYPE	DATA RATE (Mbps)
A	802.11a	149 to 165	149, 157, 165	OFDM	BPSK	6.0
A	802.11n (20MHz)	149 to 165	149, 157, 165	OFDM	BPSK	7.2
A	802.11n (40MHz)	151 to 159	151, 159	OFDM	BPSK	15.0

**TEST CONDITION:**

APPLICABLE TO	ENVIRONMENTAL CONDITIONS	INPUT POWER	TESTED BY
RE≥1G	23deg. C, 67%RH	120Vac, 60Hz	Sun Lin
RE<1G	22deg. C, 70%RH 25deg. C, 68%RH	120Vac, 60Hz 48Vdc	Sun Lin
PLC	23deg. C, 53%RH	120Vac, 60Hz 48Vdc	Skys Huang
APCM	22deg. C, 70%RH	120Vac, 60Hz	Sun Lin

### 3.3 DESCRIPTION OF SUPPORT UNITS

The EUT has been tested as an independent unit together with other necessary accessories or support units. The following support units or accessories were used to form a representative test configuration during the tests.

NO.	PRODUCT	BRAND	MODEL NO.	SERIAL NO.	FCC ID
1	NOTEBOOK	DELL	D531	CN-0XM006-48643-81U-2610	QDS-BRCM1020

NO.	SIGNAL CABLE DESCRIPTION OF THE ABOVE SUPPORT UNITS
1	10m RJ45 cable without core, 0.8m RJ45 cable without core

**NOTE:**

1. All power cords of the above support units are non shielded (1.8m).
2. Item 1 acted as communication partner to transfer data.

#### 3.3.1 CONFIGURATION OF SYSTEM UNDER TEST

**TEST MODE A**

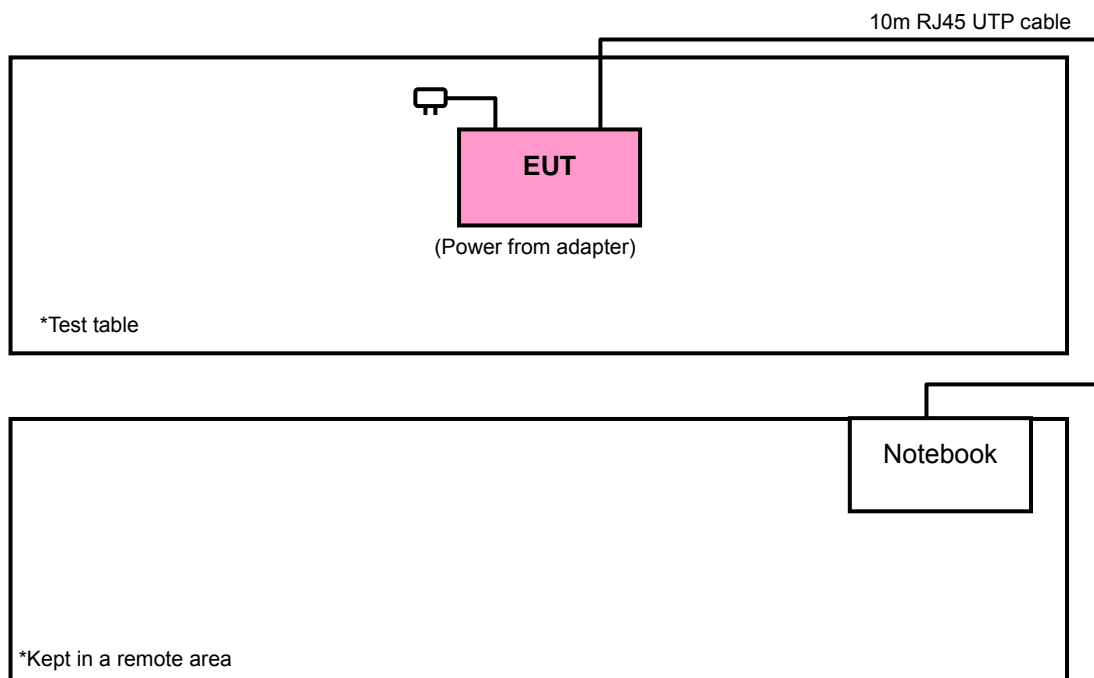



## TEST MODE B

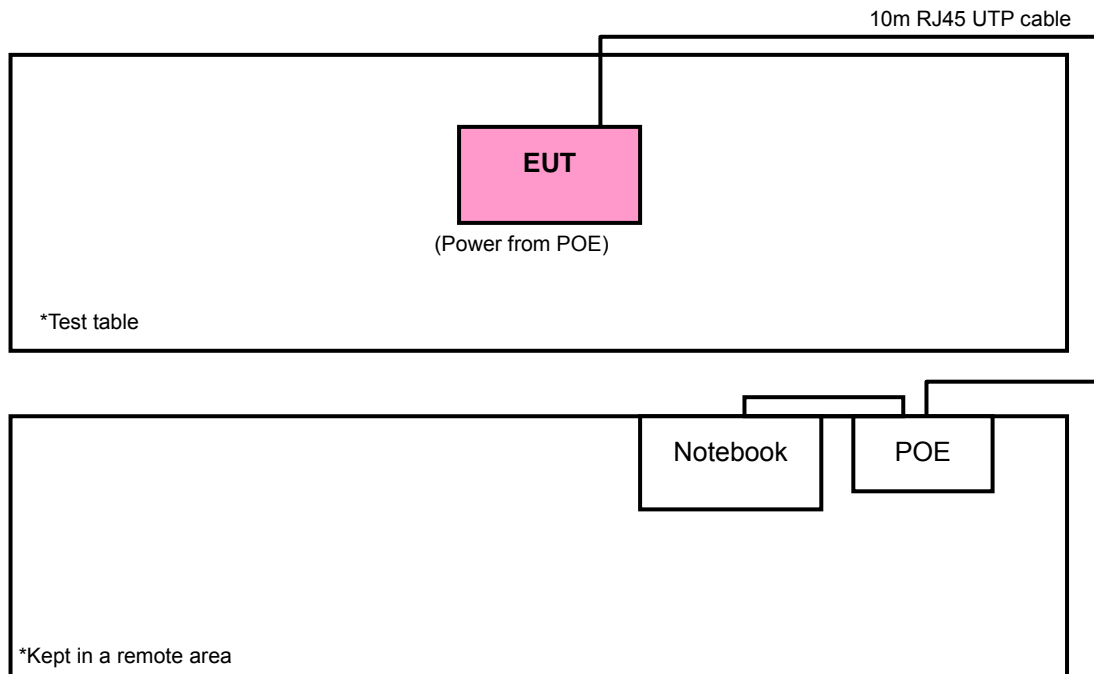

### 3.4 GENERAL DESCRIPTION OF APPLIED STANDARDS

The EUT is a RF Product. According to the specifications of the manufacturer, it must comply with the requirements of the following standards:

**FCC Part 15, Subpart C (15.247)**

**558074 D01 DTS Meas Guidance v01**

ANSI C63.10-2009

All test items have been performed and recorded as per the above standards.

**NOTE:** The EUT is also considered as a kind of computer peripheral, because the connection to computer is necessary for typical use. It has been verified to comply with the requirements of FCC Part 15, Subpart B, Class B (DoC). The test report has been issued separately.

## 4. TEST TYPES AND RESULTS (FOR 2.4GHz BAND)

### 4.1 RADIATED EMISSION AND BANDEDGE MEASUREMENT

#### 4.1.1 LIMITS OF RADIATED EMISSION AND BANDEDGE MEASUREMENT

Radiated emissions which fall in the restricted bands must comply with the radiated emission limits specified as below table. Other emissions shall be at least 20dB below the highest level of the desired power:

FREQUENCIES (MHz)	FIELD STRENGTH (microvolts/meter)	MEASUREMENT DISTANCE (meters)
0.009 ~ 0.490	2400/F(kHz)	300
0.490 ~ 1.705	24000/F(kHz)	30
1.705 ~ 30.0	30	30
30 ~ 88	100	3
88 ~ 216	150	3
216 ~ 960	200	3
Above 960	500	3

**NOTE:**

1. The lower limit shall apply at the transition frequencies.
2. Emission level (dBuV/m) = 20 log Emission level (uV/m).
3. For frequencies above 1000MHz, the field strength limits are based on average detector, however, the peak field strength of any emission shall not exceed the maximum permitted average limits, specified above by more than 20dB under any condition of modulation.

#### 4.1.2 TEST INSTRUMENTS

DESCRIPTION & MANUFACTURER	MODEL NO.	SERIAL NO.	DATE OF CALIBRATION	DUE DATE OF CALIBRATION
Test Receiver ROHDE & SCHWARZ	ESCI	100744	Apr. 19, 2012	Apr. 18, 2013
Spectrum Analyzer ROHDE & SCHWARZ	FSP40	100269	Jan. 30, 2012	Jan. 29, 2013
BILOG Antenna SCHWARZBECK	VULB9168	9168-156	Apr. 03, 2012	Apr. 02, 2013
HORN Antenna SCHWARZBECK	BBHA 9120 D	9120D-563	Sep. 06, 2011	Sep. 05, 2012
HORN Antenna SCHWARZBECK	BBHA 9170	BBHA9170243	Jan. 03, 2012	Jan. 02, 2013
Loop Antenna	HFH2-Z2	100070	Jan. 31, 2012	Jan. 30, 2014
Preamplifier Agilent	8449B	3008A01911	Oct. 29, 2011	Oct. 28, 2012
Preamplifier Agilent	8447D	2944A10638	Oct. 29, 2011	Oct. 28, 2012
RF signal cable HUBER+SUHNNER	SUCOFLEX 104	295013/4 283403/4	Aug. 19, 2011	Aug. 18, 2012
RF signal cable Worken	8D-FB	Cable-HYCH9-01	Aug. 13, 2011	Aug. 12, 2012
Software	ADT_Radiated_ V7.6.15.9.2	NA	NA	NA
Antenna Tower EMCO	2070/2080	512.835.4684	NA	NA
Turn Table EMCO	2087-2.03	NA	NA	NA
Antenna Tower & Turn Table Controller EMCO	2090	NA	NA	NA
26GHz ~ 40GHz Amplifier	EM26400	815221	Oct. 29, 2011	Oct. 28, 2012
High Speed Peak Power Meter	ML2495A	0842014	Apr. 28, 2012	Apr. 27, 2013
Power Sensor	MA2411B	0738404	Apr. 28, 2012	Apr. 27, 2013

- NOTE:** 1. The calibration interval of the above test instruments is 12 months and the calibrations are traceable to NML/ROC and NIST/USA.
2. The calibration interval of the loop antenna is 24 months and the calibrations are traceable to NML/ROC and NIST/USA.
3. The test was performed in HwaYa Chamber 4.
4. The horn antenna and HP preamplifier (model: 8449B) are used only for the measurement of emission frequency above 1GHz if tested.
5. The FCC Site Registration No. is 460141.
6. The IC Site Registration No. is IC7450F-4.

#### 4.1.3 TEST PROCEDURES

- a. The EUT was placed on the top of a rotating table 0.8 meters above the ground at a 3 meters semi-anechoic chamber. The table was rotated 360 degrees to determine the position of the highest radiation.
- b. The EUT was set 3 meters away from the interference-receiving antenna, which was mounted on the top of a variable-height antenna tower.
- c. The antenna is a broadband antenna, and its height is varied from one meter to four meters above the ground to determine the maximum value of the field strength. Both horizontal and vertical polarizations of the antenna are set to make the measurement.
- d. For each suspected emission, the EUT was arranged to its worst case and then the antenna was tuned to heights from 1 meter to 4 meters and the rotatable table was turned from 0 degrees to 360 degrees to find the maximum reading.
- e. The test-receiver system was set to Peak Detect Function and Specified Bandwidth with Maximum Hold Mode.
- f. If the emission level of the EUT in peak mode was lower than the limit specified, then testing could be stopped and the peak values of the EUT would be reported. Otherwise the emissions would be re-tested one by one using peak, quasi-peak or average method as specified and then reported in a data sheet.

**NOTE:**

1. The resolution bandwidth and video bandwidth of test receiver/spectrum analyzer is 120kHz for Quasi-peak detection at frequency below 1GHz.
2. The resolution bandwidth of test receiver/spectrum analyzer is 100kHz and video bandwidth is 300kHz for Peak detection at frequency above 1GHz.
3. The resolution bandwidth of test receiver/spectrum analyzer is 1MHz and the video bandwidth is 1kHz for Average detection (AV) at frequency above 1GHz.
4. All modes of operation were investigated and the worst-case emissions are reported.

#### 4.1.4 DEVIATION FROM TEST STANDARD

No deviation.

#### 4.1.5 TEST SETUP

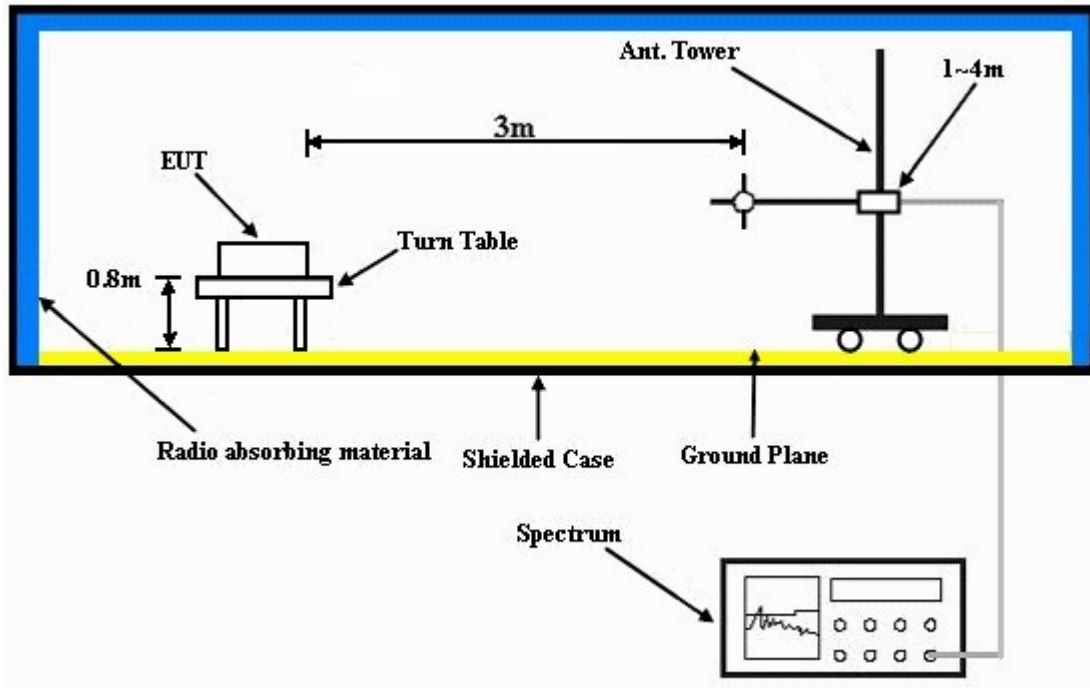

For the actual test configuration, please refer to the attached file (Test Setup Photo).

#### 4.1.6 EUT OPERATING CONDITIONS

- a. Placed the EUT on the testing table.
- b. Prepared notebooks and wireless AP to act as communication partner and placed it outside of testing area.
- c. The communication partner connected with EUT via a RJ45 cable and run a test program (provided by manufacturer) to enable EUT under transmission condition continuously at specific channel frequency.
- d. The communication partner sent data to EUT by command "PING".

#### 4.1.7 TEST RESULTS

##### ABOVE 1GHz DATA: 802.11b

EUT TEST CONDITION		MEASUREMENT DETAIL	
CHANNEL	Channel 1	FREQUENCY RANGE	1 ~ 25GHz
INPUT POWER (SYSTEM)	120Vac, 60 Hz	DETECTOR FUNCTION	Peak (PK) Average (AV)
ENVIRONMENTAL CONDITIONS	23deg. C, 67%RH	TESTED BY	Sun Lin

ANTENNA POLARITY & TEST DISTANCE: HORIZONTAL AT 3 M								
NO.	FREQ. (MHz)	EMISSION LEVEL (dBuV/m)	LIMIT (dBuV/m)	MARGIN (dB)	ANTENNA HEIGHT (m)	TABLE ANGLE (Degree)	RAW VALUE (dBuV)	CORRECTION FACTOR (dB/m)
1	2390.00	54.6 PK	74.0	-19.4	1.47 H	312	23.20	31.40
2	2390.00	44.3 AV	54.0	-9.7	1.47 H	312	12.90	31.40
3	*2412.00	98.1 PK			1.47 H	312	66.70	31.40
4	*2412.00	95.2 AV			1.47 H	312	63.80	31.40
5	4874.00	47.8 PK	74.0	-26.2	1.37 H	108	10.20	37.60
6	4874.00	40.9 AV	54.0	-13.1	1.37 H	108	3.30	37.60
ANTENNA POLARITY & TEST DISTANCE: VERTICAL AT 3 M								
NO.	FREQ. (MHz)	EMISSION LEVEL (dBuV/m)	LIMIT (dBuV/m)	MARGIN (dB)	ANTENNA HEIGHT (m)	TABLE ANGLE (Degree)	RAW VALUE (dBuV)	CORRECTION FACTOR (dB/m)
1	2390.00	57.9 PK	74.0	-16.1	1.26 V	17	26.50	31.40
2	2390.00	47.6 AV	54.0	-6.4	1.26 V	17	16.20	31.40
3	*2412.00	111.2 PK			1.26 V	16	79.80	31.40
4	*2412.00	108.1 AV			1.26 V	16	76.70	31.40
5	4824.00	49.7 PK	74.0	-24.3	1.29 V	100	12.20	37.50
6	4824.00	45.1 AV	54.0	-8.9	1.29 V	100	7.60	37.50

#### REMARKS:

1. Emission level (dBuV/m) = Raw Value (dBuV) + Correction Factor (dB/m).
2. Correction Factor (dB/m) = Antenna Factor (dB/m) + Cable Factor (dB).
3. The other emission levels were very low against the limit.
4. Margin value = Emission level – Limit value.
5. “ \* ”: Fundamental frequency.

EUT TEST CONDITION		MEASUREMENT DETAIL	
CHANNEL	Channel 6	FREQUENCY RANGE	1 ~ 25GHz
INPUT POWER (SYSTEM)	120Vac, 60 Hz	DETECTOR FUNCTION	Peak (PK) Average (AV)
ENVIRONMENTAL CONDITIONS	23deg. C, 67%RH	TESTED BY	Sun Lin

ANTENNA POLARITY & TEST DISTANCE: HORIZONTAL AT 3 M								
NO.	FREQ. (MHz)	EMISSION LEVEL (dBuV/m)	LIMIT (dBuV/m)	MARGIN (dB)	ANTENNA HEIGHT (m)	TABLE ANGLE (Degree)	RAW VALUE (dBuV)	CORRECTION FACTOR (dB/m)
1	*2437.00	97.9 PK			1.01 H	167	66.40	31.50
2	*2437.00	95.3 AV			1.01 H	167	63.80	31.50
3	4874.00	47.5 PK	74.0	-26.5	1.22 H	88	9.90	37.60
4	4874.00	40.0 AV	54.0	-14.0	1.22 H	88	2.40	37.60
5	7311.00	49.4 PK	74.0	-24.6	1.02 H	357	5.70	43.70
6	7311.00	39.3 AV	54.0	-14.7	1.02 H	357	-4.40	43.70
ANTENNA POLARITY & TEST DISTANCE: VERTICAL AT 3 M								
NO.	FREQ. (MHz)	EMISSION LEVEL (dBuV/m)	LIMIT (dBuV/m)	MARGIN (dB)	ANTENNA HEIGHT (m)	TABLE ANGLE (Degree)	RAW VALUE (dBuV)	CORRECTION FACTOR (dB/m)
1	*2437.00	111.0 PK			1.00 V	204	79.50	31.50
2	*2437.00	107.9 AV			1.00 V	204	76.40	31.50
3	4874.00	50.1 PK	74.0	-23.9	1.12 V	255	12.50	37.60
4	4874.00	45.3 AV	54.0	-8.7	1.12 V	255	7.70	37.60
5	7311.00	50.4 PK	74.0	-23.6	1.34 V	25	6.70	43.70
6	7311.00	40.0 AV	54.0	-14.0	1.34 V	25	-3.70	43.70

**REMARKS:**

1. Emission level (dBuV/m) = Raw Value (dBuV) + Correction Factor (dB/m).
2. Correction Factor (dB/m) = Antenna Factor (dB/m) + Cable Factor (dB).
3. The other emission levels were very low against the limit.
4. Margin value = Emission level – Limit value.
5. “ \* “: Fundamental frequency.

EUT TEST CONDITION		MEASUREMENT DETAIL	
CHANNEL	Channel 11	FREQUENCY RANGE	1 ~ 25GHz
INPUT POWER (SYSTEM)	120Vac, 60 Hz	DETECTOR FUNCTION	Peak (PK) Average (AV)
ENVIRONMENTAL CONDITIONS	23deg. C, 67%RH	TESTED BY	Sun Lin

ANTENNA POLARITY & TEST DISTANCE: HORIZONTAL AT 3 M								
NO.	FREQ. (MHz)	EMISSION LEVEL (dBuV/m)	LIMIT (dBuV/m)	MARGIN (dB)	ANTENNA HEIGHT (m)	TABLE ANGLE (Degree)	RAW VALUE (dBuV)	CORRECTION FACTOR (dB/m)
1	*2462.00	97.9 PK			1.39 H	301	66.30	31.60
2	*2462.00	95.0 AV			1.39 H	301	63.40	31.60
3	2483.50	54.3 PK	74.0	-19.7	1.39 H	301	22.60	31.70
4	2483.50	44.2 AV	54.0	-9.8	1.39 H	301	12.50	31.70
5	4924.00	48.2 PK	74.0	-25.8	1.32 H	98	10.50	37.70
6	4924.00	41.3 AV	54.0	-12.7	1.32 H	98	3.60	37.70
ANTENNA POLARITY & TEST DISTANCE: VERTICAL AT 3 M								
NO.	FREQ. (MHz)	EMISSION LEVEL (dBuV/m)	LIMIT (dBuV/m)	MARGIN (dB)	ANTENNA HEIGHT (m)	TABLE ANGLE (Degree)	RAW VALUE (dBuV)	CORRECTION FACTOR (dB/m)
1	*2462.00	111.0 PK			1.00 V	18	79.40	31.60
2	*2462.00	108.0 AV			1.00 V	18	76.40	31.60
3	2483.50	58.7 PK	74.0	-15.3	1.00 V	18	27.00	31.70
4	2483.50	48.6 AV	54.0	-5.4	1.00 V	18	16.90	31.70
5	4924.00	49.8 PK	74.0	-24.2	1.30 V	59	12.10	37.70
6	4924.00	44.7 AV	54.0	-9.3	1.30 V	59	7.00	37.70

**REMARKS:**

1. Emission level (dBuV/m) = Raw Value (dBuV) + Correction Factor (dB/m).
2. Correction Factor (dB/m) = Antenna Factor (dB/m) + Cable Factor (dB).
3. The other emission levels were very low against the limit.
4. Margin value = Emission level – Limit value.
5. “ \* “: Fundamental frequency.



802.11g

EUT TEST CONDITION		MEASUREMENT DETAIL	
CHANNEL	Channel 1	FREQUENCY RANGE	1 ~ 25GHz
INPUT POWER (SYSTEM)	120Vac, 60 Hz	DETECTOR FUNCTION	Peak (PK) Average (AV)
ENVIRONMENTAL CONDITIONS	23deg. C, 67%RH	TESTED BY	Sun Lin

ANTENNA POLARITY & TEST DISTANCE: HORIZONTAL AT 3 M								
NO.	FREQ. (MHz)	EMISSION LEVEL (dBuV/m)	LIMIT (dBuV/m)	MARGIN (dB)	ANTENNA HEIGHT (m)	TABLE ANGLE (Degree)	RAW VALUE (dBuV)	CORRECTION FACTOR (dB/m)
1	2390.00	63.2 PK	74.0	-10.8	1.07 H	334	31.80	31.40
2	2390.00	47.0 AV	54.0	-7.0	1.07 H	334	15.60	31.40
3	*2412.00	102.3 PK			1.08 H	347	70.90	31.40
4	*2412.00	93.0 AV			1.08 H	347	61.60	31.40
5	4824.00	50.7 PK	74.0	-23.3	1.00 H	304	13.20	37.50
6	4824.00	36.2 AV	54.0	-17.8	1.00 H	304	-1.30	37.50

ANTENNA POLARITY & TEST DISTANCE: VERTICAL AT 3 M								
NO.	FREQ. (MHz)	EMISSION LEVEL (dBuV/m)	LIMIT (dBuV/m)	MARGIN (dB)	ANTENNA HEIGHT (m)	TABLE ANGLE (Degree)	RAW VALUE (dBuV)	CORRECTION FACTOR (dB/m)
1	2390.00	71.9 PK	74.0	-2.1	1.01 V	352	40.50	31.40
2	2390.00	53.0 AV	54.0	-1.0	1.01 V	352	21.60	31.40
3	*2412.00	114.2 PK			1.00 V	358	82.80	31.40
4	*2412.00	105.3 AV			1.00 V	358	73.90	31.40
5	4824.00	48.9 PK	74.0	-25.1	1.08 V	67	11.40	37.50
6	4824.00	34.7 AV	54.0	-19.3	1.08 V	67	-2.80	37.50

REMARKS:

1. Emission level (dBuV/m) = Raw Value (dBuV) + Correction Factor (dB/m).
2. Correction Factor (dB/m) = Antenna Factor (dB/m) + Cable Factor (dB).
3. The other emission levels were very low against the limit.
4. Margin value = Emission level – Limit value.
5. “ \* “: Fundamental frequency.

EUT TEST CONDITION		MEASUREMENT DETAIL	
CHANNEL	Channel 6	FREQUENCY RANGE	1 ~ 25GHz
INPUT POWER (SYSTEM)	120Vac, 60 Hz	DETECTOR FUNCTION	Peak (PK) Average (AV)
ENVIRONMENTAL CONDITIONS	23deg. C, 67%RH	TESTED BY	Sun Lin

ANTENNA POLARITY & TEST DISTANCE: HORIZONTAL AT 3 M								
NO.	FREQ. (MHz)	EMISSION LEVEL (dBuV/m)	LIMIT (dBuV/m)	MARGIN (dB)	ANTENNA HEIGHT (m)	TABLE ANGLE (Degree)	RAW VALUE (dBuV)	CORRECTION FACTOR (dB/m)
1	2377.00	57.0 PK	74.0	-17.0	1.38 H	58	25.70	31.30
2	2377.00	45.9 AV	54.0	-8.1	1.38 H	58	14.60	31.30
3	*2437.00	104.2 PK			1.31 H	95	72.70	31.50
4	*2437.00	95.4 AV			1.31 H	95	63.90	31.50
5	4874.00	53.4 PK	74.0	-20.6	1.02 H	298	15.80	37.60
6	4874.00	38.9 AV	54.0	-15.1	1.02 H	298	1.30	37.60
ANTENNA POLARITY & TEST DISTANCE: VERTICAL AT 3 M								
NO.	FREQ. (MHz)	EMISSION LEVEL (dBuV/m)	LIMIT (dBuV/m)	MARGIN (dB)	ANTENNA HEIGHT (m)	TABLE ANGLE (Degree)	RAW VALUE (dBuV)	CORRECTION FACTOR (dB/m)
1	2377.00	60.9 PK	74.0	-13.1	1.03 V	18	29.60	31.30
2	2377.00	53.0 AV	54.0	-1.0	1.03 V	18	21.70	31.30
3	*2437.00	116.2 PK			1.00 V	10	84.70	31.50
4	*2437.00	107.1 AV			1.00 V	10	75.60	31.50
5	4874.00	50.2 PK	74.0	-23.8	1.00 V	61	12.60	37.60
6	4874.00	36.2 AV	54.0	-17.8	1.00 V	61	-1.40	37.60

**REMARKS:**

1. Emission level (dBuV/m) = Raw Value (dBuV) + Correction Factor (dB/m).
2. Correction Factor (dB/m) = Antenna Factor (dB/m) + Cable Factor (dB).
3. The other emission levels were very low against the limit.
4. Margin value = Emission level – Limit value.
5. “ \* “: Fundamental frequency.

EUT TEST CONDITION		MEASUREMENT DETAIL	
CHANNEL	Channel 11	FREQUENCY RANGE	1 ~ 25GHz
INPUT POWER (SYSTEM)	120Vac, 60 Hz	DETECTOR FUNCTION	Peak (PK) Average (AV)
ENVIRONMENTAL CONDITIONS	23deg. C, 67%RH	TESTED BY	Sun Lin

ANTENNA POLARITY & TEST DISTANCE: HORIZONTAL AT 3 M								
NO.	FREQ. (MHz)	EMISSION LEVEL (dBuV/m)	LIMIT (dBuV/m)	MARGIN (dB)	ANTENNA HEIGHT (m)	TABLE ANGLE (Degree)	RAW VALUE (dBuV)	CORRECTION FACTOR (dB/m)
1	*2462.00	101.5 PK			1.08 H	347	69.90	31.60
2	*2462.00	92.2 AV			1.08 H	347	60.60	31.60
3	2483.50	60.1 PK	74.0	-13.9	1.07 H	352	28.40	31.70
4	2483.50	45.8 AV	54.0	-8.2	1.07 H	352	14.10	31.70
5	4924.00	50.6 PK	74.0	-23.4	1.04 H	299	12.90	37.70
6	4924.00	36.3 AV	54.0	-17.7	1.04 H	299	-1.40	37.70
ANTENNA POLARITY & TEST DISTANCE: VERTICAL AT 3 M								
NO.	FREQ. (MHz)	EMISSION LEVEL (dBuV/m)	LIMIT (dBuV/m)	MARGIN (dB)	ANTENNA HEIGHT (m)	TABLE ANGLE (Degree)	RAW VALUE (dBuV)	CORRECTION FACTOR (dB/m)
1	*2462.00	113.5 PK			1.00 V	18	81.90	31.60
2	*2462.00	104.3 AV			1.00 V	18	72.70	31.60
3	2483.50	67.5 PK	74.0	-6.5	1.00 V	11	35.80	31.70
4	2483.50	52.9 AV	54.0	-1.1	1.00 V	11	21.20	31.70
5	4924.00	48.3 PK	74.0	-25.7	1.07 V	108	10.60	37.70
6	4924.00	34.2 AV	54.0	-19.8	1.07 V	108	-3.50	37.70

**REMARKS:**

1. Emission level (dBuV/m) = Raw Value (dBuV) + Correction Factor (dB/m).
2. Correction Factor (dB/m) = Antenna Factor (dB/m) + Cable Factor (dB).
3. The other emission levels were very low against the limit.
4. Margin value = Emission level – Limit value.
5. “ \* “: Fundamental frequency.

802.11n (20MHz)

EUT TEST CONDITION		MEASUREMENT DETAIL	
CHANNEL	Channel 1	FREQUENCY RANGE	1 ~ 25GHz
INPUT POWER (SYSTEM)	120Vac, 60 Hz	DETECTOR FUNCTION	Peak (PK) Average (AV)
ENVIRONMENTAL CONDITIONS	23deg. C, 67%RH	TESTED BY	Sun Lin

ANTENNA POLARITY & TEST DISTANCE: HORIZONTAL AT 3 M								
NO.	FREQ. (MHz)	EMISSION LEVEL (dBuV/m)	LIMIT (dBuV/m)	MARGIN (dB)	ANTENNA HEIGHT (m)	TABLE ANGLE (Degree)	RAW VALUE (dBuV)	CORRECTION FACTOR (dB/m)
1	2390.00	61.7 PK	74.0	-12.3	1.08 H	328	30.30	31.40
2	2390.00	46.7 AV	54.0	-7.3	1.08 H	328	15.30	31.40
3	*2412.00	99.8 PK			1.08 H	328	68.40	31.40
4	*2412.00	90.1 AV			1.08 H	328	58.70	31.40
5	4824.00	48.3 PK	74.0	-25.7	1.02 H	312	10.80	37.50
6	4824.00	35.2 AV	54.0	-18.8	1.02 H	312	-2.30	37.50

ANTENNA POLARITY & TEST DISTANCE: VERTICAL AT 3 M								
NO.	FREQ. (MHz)	EMISSION LEVEL (dBuV/m)	LIMIT (dBuV/m)	MARGIN (dB)	ANTENNA HEIGHT (m)	TABLE ANGLE (Degree)	RAW VALUE (dBuV)	CORRECTION FACTOR (dB/m)
1	2390.00	68.6 PK	74.0	-5.4	1.03 V	17	37.20	31.40
2	2390.00	53.0 AV	54.0	-1.0	1.03 V	17	21.60	31.40
3	*2412.00	111.8 PK			1.03 V	12	80.40	31.40
4	*2412.00	102.2 AV			1.03 V	12	70.80	31.40
5	4824.00	46.8 PK	74.0	-27.2	1.07 V	77	9.30	37.50
6	4824.00	32.8 AV	54.0	-21.2	1.07 V	77	-4.70	37.50

REMARKS:

1. Emission level (dBuV/m) = Raw Value (dBuV) + Correction Factor (dB/m).
2. Correction Factor (dB/m) = Antenna Factor (dB/m) + Cable Factor (dB).
3. The other emission levels were very low against the limit.
4. Margin value = Emission level – Limit value.
5. “ \* “: Fundamental frequency.

EUT TEST CONDITION		MEASUREMENT DETAIL	
CHANNEL	Channel 6	FREQUENCY RANGE	1 ~ 25GHz
INPUT POWER (SYSTEM)	120Vac, 60 Hz	DETECTOR FUNCTION	Peak (PK) Average (AV)
ENVIRONMENTAL CONDITIONS	23deg. C, 67%RH	TESTED BY	Sun Lin

ANTENNA POLARITY & TEST DISTANCE: HORIZONTAL AT 3 M								
NO.	FREQ. (MHz)	EMISSION LEVEL (dBuV/m)	LIMIT (dBuV/m)	MARGIN (dB)	ANTENNA HEIGHT (m)	TABLE ANGLE (Degree)	RAW VALUE (dBuV)	CORRECTION FACTOR (dB/m)
1	2377.00	57.2 PK	74.0	-16.8	1.38 H	69	25.90	31.30
2	2377.00	46.0 AV	54.0	-8.0	1.38 H	69	14.70	31.30
3	*2437.00	104.0 PK			1.35 H	102	72.50	31.50
4	*2437.00	94.7 AV			1.35 H	102	63.20	31.50
5	4874.00	53.2 PK	74.0	-20.8	1.08 H	304	15.60	37.60
6	4874.00	38.6 AV	54.0	-15.4	1.08 H	304	1.00	37.60
ANTENNA POLARITY & TEST DISTANCE: VERTICAL AT 3 M								
NO.	FREQ. (MHz)	EMISSION LEVEL (dBuV/m)	LIMIT (dBuV/m)	MARGIN (dB)	ANTENNA HEIGHT (m)	TABLE ANGLE (Degree)	RAW VALUE (dBuV)	CORRECTION FACTOR (dB/m)
1	2377.00	60.8 PK	74.0	-13.2	1.04 V	22	29.50	31.30
2	2377.00	52.6 AV	54.0	-1.4	1.04 V	22	21.30	31.30
3	*2437.00	116.3 PK			1.00 V	18	84.80	31.50
4	*2437.00	106.5 AV			1.00 V	18	75.00	31.50
5	4874.00	50.6 PK	74.0	-23.4	1.04 V	69	13.00	37.60
6	4874.00	36.5 AV	54.0	-17.5	1.04 V	69	-1.10	37.60

**REMARKS:**

1. Emission level (dBuV/m) = Raw Value (dBuV) + Correction Factor (dB/m).
2. Correction Factor (dB/m) = Antenna Factor (dB/m) + Cable Factor (dB).
3. The other emission levels were very low against the limit.
4. Margin value = Emission level – Limit value.
5. “ \* “: Fundamental frequency.

EUT TEST CONDITION		MEASUREMENT DETAIL	
CHANNEL	Channel 11	FREQUENCY RANGE	1 ~ 25GHz
INPUT POWER (SYSTEM)	120Vac, 60 Hz	DETECTOR FUNCTION	Peak (PK) Average (AV)
ENVIRONMENTAL CONDITIONS	23deg. C, 67%RH	TESTED BY	Sun Lin

ANTENNA POLARITY & TEST DISTANCE: HORIZONTAL AT 3 M								
NO.	FREQ. (MHz)	EMISSION LEVEL (dBuV/m)	LIMIT (dBuV/m)	MARGIN (dB)	ANTENNA HEIGHT (m)	TABLE ANGLE (Degree)	RAW VALUE (dBuV)	CORRECTION FACTOR (dB/m)
1	*2462.00	100.0 PK			1.07 H	335	68.40	31.60
2	*2462.00	90.3 AV			1.07 H	335	58.70	31.60
3	2483.50	61.8 PK	74.0	-12.2	1.07 H	342	30.10	31.70
4	2483.50	46.9 AV	54.0	-7.1	1.07 H	342	15.20	31.70
5	4924.00	48.1 PK	74.0	-25.9	1.04 H	305	10.40	37.70
6	4924.00	34.9 AV	54.0	-19.1	1.04 H	305	-2.80	37.70
ANTENNA POLARITY & TEST DISTANCE: VERTICAL AT 3 M								
NO.	FREQ. (MHz)	EMISSION LEVEL (dBuV/m)	LIMIT (dBuV/m)	MARGIN (dB)	ANTENNA HEIGHT (m)	TABLE ANGLE (Degree)	RAW VALUE (dBuV)	CORRECTION FACTOR (dB/m)
1	*2462.00	112.0 PK			1.00 V	21	80.40	31.60
2	*2462.00	102.3 AV			1.00 V	21	70.70	31.60
3	2483.50	69.5 PK	74.0	-4.5	1.01 V	32	37.80	31.70
4	2483.50	52.9 AV	54.0	-1.1	1.01 V	32	21.20	31.70
5	4924.00	47.2 PK	74.0	-26.8	1.08 V	82	9.50	37.70
6	4924.00	33.5 AV	54.0	-20.5	1.08 V	82	-4.20	37.70

**REMARKS:**

1. Emission level (dBuV/m) = Raw Value (dBuV) + Correction Factor (dB/m).
2. Correction Factor (dB/m) = Antenna Factor (dB/m) + Cable Factor (dB).
3. The other emission levels were very low against the limit.
4. Margin value = Emission level – Limit value.
5. “ \* “: Fundamental frequency.

802.11n (40MHz)

EUT TEST CONDITION		MEASUREMENT DETAIL	
CHANNEL	Channel 3	FREQUENCY RANGE	1 ~ 25GHz
INPUT POWER (SYSTEM)	120Vac, 60 Hz	DETECTOR FUNCTION	Peak (PK) Average (AV)
ENVIRONMENTAL CONDITIONS	23deg. C, 67%RH	TESTED BY	Sun Lin

ANTENNA POLARITY & TEST DISTANCE: HORIZONTAL AT 3 M								
NO.	FREQ. (MHz)	EMISSION LEVEL (dBuV/m)	LIMIT (dBuV/m)	MARGIN (dB)	ANTENNA HEIGHT (m)	TABLE ANGLE (Degree)	RAW VALUE (dBuV)	CORRECTION FACTOR (dB/m)
1	2390.00	61.3 PK	74.0	-12.7	1.04 H	353	29.90	31.40
2	2390.00	46.1 AV	54.0	-7.9	1.04 H	353	14.70	31.40
3	*2422.00	94.3 PK			1.12 H	334	62.80	31.50
4	*2422.00	84.2 AV			1.12 H	334	52.70	31.50
5	4844.00	42.5 PK	74.0	-31.5	1.08 H	302	5.00	37.50
6	4844.00	32.0 AV	54.0	-22.0	1.08 H	302	-5.50	37.50

ANTENNA POLARITY & TEST DISTANCE: VERTICAL AT 3 M								
NO.	FREQ. (MHz)	EMISSION LEVEL (dBuV/m)	LIMIT (dBuV/m)	MARGIN (dB)	ANTENNA HEIGHT (m)	TABLE ANGLE (Degree)	RAW VALUE (dBuV)	CORRECTION FACTOR (dB/m)
1	2390.00	67.2 PK	74.0	-6.8	1.04 V	12	35.80	31.40
2	2390.00	53.0 AV	54.0	-1.0	1.04 V	12	21.60	31.40
3	*2422.00	106.1 PK			1.25 V	17	74.60	31.50
4	*2422.00	96.4 AV			1.25 V	17	64.90	31.50
5	4844.00	43.4 PK	74.0	-30.6	1.07 V	77	5.90	37.50
6	4844.00	33.2 AV	54.0	-20.8	1.07 V	77	-4.30	37.50

REMARKS:

1. Emission level (dBuV/m) = Raw Value (dBuV) + Correction Factor (dB/m).
2. Correction Factor (dB/m) = Antenna Factor (dB/m) + Cable Factor (dB).
3. The other emission levels were very low against the limit.
4. Margin value = Emission level – Limit value.
5. “ \* “: Fundamental frequency.

EUT TEST CONDITION		MEASUREMENT DETAIL	
CHANNEL	Channel 6	FREQUENCY RANGE	1 ~ 25GHz
INPUT POWER (SYSTEM)	120Vac, 60 Hz	DETECTOR FUNCTION	Peak (PK) Average (AV)
ENVIRONMENTAL CONDITIONS	23deg. C, 67%RH	TESTED BY	Sun Lin

ANTENNA POLARITY & TEST DISTANCE: HORIZONTAL AT 3 M								
NO.	FREQ. (MHz)	EMISSION LEVEL (dBuV/m)	LIMIT (dBuV/m)	MARGIN (dB)	ANTENNA HEIGHT (m)	TABLE ANGLE (Degree)	RAW VALUE (dBuV)	CORRECTION FACTOR (dB/m)
1	2390.00	60.8 PK	74.0	-13.2	1.08 H	331	29.40	31.40
2	2390.00	45.8 AV	54.0	-8.2	1.08 H	331	14.40	31.40
3	*2437.00	96.5 PK			1.08 H	335	65.00	31.50
4	*2437.00	87.7 AV			1.08 H	335	56.20	31.50
5	2483.50	58.1 PK	74.0	-15.9	1.08 H	331	26.40	31.70
6	2483.50	43.2 AV	54.0	-10.8	1.08 H	331	11.50	31.70
7	4874.00	45.7 PK	74.0	-28.3	1.03 H	299	8.10	37.60
8	4874.00	34.6 AV	54.0	-19.4	1.03 H	299	-3.00	37.60
ANTENNA POLARITY & TEST DISTANCE: VERTICAL AT 3 M								
NO.	FREQ. (MHz)	EMISSION LEVEL (dBuV/m)	LIMIT (dBuV/m)	MARGIN (dB)	ANTENNA HEIGHT (m)	TABLE ANGLE (Degree)	RAW VALUE (dBuV)	CORRECTION FACTOR (dB/m)
1	2390.00	66.3 PK	74.0	-7.7	1.02 V	12	34.90	31.40
2	2390.00	52.7 AV	54.0	-1.3	1.02 V	12	21.30	31.40
3	*2437.00	109.5 PK			1.03 V	12	78.00	31.50
4	*2437.00	100.1 AV			1.03 V	12	68.60	31.50
5	2483.50	64.4 PK	74.0	-9.6	1.03 V	12	32.70	31.70
6	2483.50	50.5 AV	54.0	-3.5	1.03 V	12	18.80	31.70
7	4874.00	47.3 PK	74.0	-26.7	1.08 V	98	9.70	37.60
8	4874.00	37.2 AV	54.0	-16.8	1.08 V	98	-0.40	37.60

**REMARKS:**

1. Emission level (dBuV/m) = Raw Value (dBuV) + Correction Factor (dB/m).
2. Correction Factor (dB/m) = Antenna Factor (dB/m) + Cable Factor (dB).
3. The other emission levels were very low against the limit.
4. Margin value = Emission level – Limit value.
5. “ \* “: Fundamental frequency.



EUT TEST CONDITION		MEASUREMENT DETAIL	
CHANNEL	Channel 9	FREQUENCY RANGE	1 ~ 25GHz
INPUT POWER (SYSTEM)	120Vac, 60 Hz	DETECTOR FUNCTION	Peak (PK) Average (AV)
ENVIRONMENTAL CONDITIONS	23deg. C, 67%RH	TESTED BY	Sun Lin

ANTENNA POLARITY & TEST DISTANCE: HORIZONTAL AT 3 M								
NO.	FREQ. (MHz)	EMISSION LEVEL (dBuV/m)	LIMIT (dBuV/m)	MARGIN (dB)	ANTENNA HEIGHT (m)	TABLE ANGLE (Degree)	RAW VALUE (dBuV)	CORRECTION FACTOR (dB/m)
1	*2452.00	94.5 PK			1.05 H	351	62.90	31.60
2	*2452.00	84.5 AV			1.05 H	351	52.90	31.60
3	2483.50	61.7 PK	74.0	-12.3	1.05 H	347	30.00	31.70
4	2483.50	46.3 AV	54.0	-7.7	1.05 H	347	14.60	31.70
5	4904.00	42.8 PK	74.0	-31.2	1.12 H	327	5.20	37.60
6	4904.00	32.7 AV	54.0	-21.3	1.12 H	327	-4.90	37.60
ANTENNA POLARITY & TEST DISTANCE: VERTICAL AT 3 M								
NO.	FREQ. (MHz)	EMISSION LEVEL (dBuV/m)	LIMIT (dBuV/m)	MARGIN (dB)	ANTENNA HEIGHT (m)	TABLE ANGLE (Degree)	RAW VALUE (dBuV)	CORRECTION FACTOR (dB/m)
1	*2452.00	106.1 PK			1.00 V	13	74.50	31.60
2	*2452.00	96.7 AV			1.00 V	13	65.10	31.60
3	2483.50	64.0 PK	74.0	-10.0	1.00 V	18	32.30	31.70
4	2483.50	53.0 AV	54.0	-1.0	1.00 V	18	21.30	31.70
5	4904.00	43.8 PK	74.0	-30.2	1.05 V	69	6.20	37.60
6	4904.00	33.7 AV	54.0	-20.3	1.05 V	69	-3.90	37.60

**REMARKS:**

1. Emission level (dBuV/m) = Raw Value (dBuV) + Correction Factor (dB/m).
2. Correction Factor (dB/m) = Antenna Factor (dB/m) + Cable Factor (dB).
3. The other emission levels were very low against the limit.
4. Margin value = Emission level – Limit value.
5. “ \* “: Fundamental frequency.

**BELOW 1GHz WORST-CASE DATA : 802.11n (20MHz)**

EUT TEST CONDITION		MEASUREMENT DETAIL	
CHANNEL	Channel 6	FREQUENCY RANGE	Below 1000MHz
INPUT POWER (SYSTEM)	120Vac, 60 Hz	DETECTOR FUNCTION	Quasi-Peak
ENVIRONMENTAL CONDITIONS	22deg. C, 70%RH	TEST MODE	A
TESTED BY	Sun Lin		

ANTENNA POLARITY & TEST DISTANCE: HORIZONTAL AT 3 M								
NO.	FREQ. (MHz)	EMISSION LEVEL (dBuV/m)	LIMIT (dBuV/m)	MARGIN (dB)	ANTENNA HEIGHT (m)	TABLE ANGLE (Degree)	RAW VALUE (dBuV)	CORRECTION FACTOR (dB/m)
1	148.34	32.9 QP	43.5	-10.6	2.25 H	105	19.00	13.90
2	210.42	31.3 QP	43.5	-12.2	1.25 H	115	19.70	11.60
3	286.08	29.0 QP	46.0	-17.0	1.00 H	98	14.60	14.40
4	454.86	35.0 QP	46.0	-11.0	1.50 H	25	16.10	18.90
5	499.48	31.2 QP	46.0	-14.8	1.50 H	216	11.10	20.10
6	625.58	32.5 QP	46.0	-13.5	1.00 H	17	10.00	22.50
ANTENNA POLARITY & TEST DISTANCE: VERTICAL AT 3 M								
NO.	FREQ. (MHz)	EMISSION LEVEL (dBuV/m)	LIMIT (dBuV/m)	MARGIN (dB)	ANTENNA HEIGHT (m)	TABLE ANGLE (Degree)	RAW VALUE (dBuV)	CORRECTION FACTOR (dB/m)
1	146.40	34.4 QP	43.5	-9.1	1.00 V	221	20.60	13.80
2	218.18	29.3 QP	46.0	-16.7	1.00 V	280	17.40	11.90
3	280.26	27.8 QP	46.0	-18.2	1.25 V	175	13.60	14.20
4	454.86	29.4 QP	46.0	-16.6	1.00 V	2	10.50	18.90
5	625.58	31.2 QP	46.0	-14.8	1.50 V	34	8.70	22.50
6	875.84	35.0 QP	46.0	-11.0	1.00 V	4	9.00	26.00

**REMARKS:**

1. Emission level (dBuV/m) = Raw Value (dBuV) + Correction Factor (dB/m).
2. Correction Factor (dB/m) = Antenna Factor (dB/m) + Cable Factor (dB).
3. The other emission levels were very low against the limit.
4. Margin value = Emission level – Limit value.

EUT TEST CONDITION		MEASUREMENT DETAIL	
CHANNEL	Channel 6	FREQUENCY RANGE	Below 1000MHz
INPUT POWER (SYSTEM)	120Vac, 60 Hz	DETECTOR FUNCTION	Quasi-Peak
ENVIRONMENTAL CONDITIONS	25deg. C, 68%RH	TEST MODE	B
TESTED BY	Sun Lin		

ANTENNA POLARITY & TEST DISTANCE: HORIZONTAL AT 3 M								
NO.	FREQ. (MHz)	EMISSION LEVEL (dBuV/m)	LIMIT (dBuV/m)	MARGIN (dB)	ANTENNA HEIGHT (m)	TABLE ANGLE (Degree)	RAW VALUE (dBuV)	CORRECTION FACTOR (dB/m)
1	169.68	31.9 QP	43.5	-11.6	1.50 H	105	18.40	13.50
2	280.26	28.1 QP	46.0	-17.9	1.25 H	288	13.90	14.20
3	452.92	31.9 QP	46.0	-14.1	1.50 H	264	13.10	18.80
4	499.48	29.8 QP	46.0	-16.2	1.25 H	194	9.70	20.10
5	625.58	29.4 QP	46.0	-16.6	1.25 H	223	6.90	22.50
6	875.84	31.6 QP	46.0	-14.4	1.25 H	233	5.60	26.00
ANTENNA POLARITY & TEST DISTANCE: VERTICAL AT 3 M								
NO.	FREQ. (MHz)	EMISSION LEVEL (dBuV/m)	LIMIT (dBuV/m)	MARGIN (dB)	ANTENNA HEIGHT (m)	TABLE ANGLE (Degree)	RAW VALUE (dBuV)	CORRECTION FACTOR (dB/m)
1	80.44	32.6 QP	40.0	-7.4	1.00 V	13	22.80	9.80
2	189.08	29.6 QP	43.5	-13.9	1.00 V	206	17.60	12.00
3	280.26	30.1 QP	46.0	-15.9	2.00 V	11	15.90	14.20
4	452.92	27.8 QP	46.0	-18.2	1.50 V	178	9.00	18.80
5	625.58	29.2 QP	46.0	-16.8	1.50 V	179	6.70	22.50
6	875.84	33.2 QP	46.0	-12.8	1.00 V	154	7.20	26.00

**REMARKS:**

1. Emission level (dBuV/m) = Raw Value (dBuV) + Correction Factor (dB/m).
2. Correction Factor (dB/m) = Antenna Factor (dB/m) + Cable Factor (dB).
3. The other emission levels were very low against the limit.
4. Margin value = Emission level – Limit value.

## 4.2 CONDUCTED EMISSION MEASUREMENT

### 4.2.1 LIMITS OF CONDUCTED EMISSION MEASUREMENT

FREQUENCY OF EMISSION (MHz)	CONDUCTED LIMIT (dB $\mu$ V)	
	Quasi-peak	Average
0.15 ~ 0.5	66 to 56	56 to 46
0.5 ~ 5	56	46
5 ~ 30	60	50

- NOTE:**
1. The lower limit shall apply at the transition frequencies.
  2. The limit decreases in line with the logarithm of the frequency in the range of 0.15 to 0.50MHz.
  3. All emanations from a class A/B digital device or system, including any network of conductors and apparatus connected thereto, shall not exceed the level of field strengths specified above.

### 4.2.2 TEST INSTRUMENTS

DESCRIPTION & MANUFACTURER	MODEL NO.	SERIAL NO.	DATE OF CALIBRATION	DUE DATE OF CALIBRATION
Test Receiver ROHDE & SCHWARZ	ESCS30	100291	Nov. 23, 2011	Nov. 22, 2012
RF signal cable Woken	5D-FB	Cable-HYC01-01	Dec. 29, 2011	Dec. 28, 2012
LISN ROHDE & SCHWARZ (Peripheral)	ESH3-Z5	100312	Jul. 02, 2012	Jul. 01, 2013
LISN ROHDE & SCHWARZ (EUT)	ESH3-Z5	835239/001	Feb. 07, 2012	Feb. 06, 2013
Software ADT	BV ADT_Cond_ V7.3.7.3	NA	NA	NA

- NOTE:**
1. The calibration interval of the above test instruments is 12 months and the calibrations are traceable to NML/ROC and NIST/USA.
  2. The test was performed in HwaYa Shielded Room 1.
  3. The VCCI Site Registration No. is C-2040.

#### 4.2.3 TEST PROCEDURES

- a. The EUT was placed 0.4 meters from the conducting wall of the shielded room with EUT being connected to the power mains through a line impedance stabilization network (LISN). Other support units were connected to the power mains through another LISN. The two LISNs provide 50 ohm/ 50uH of coupling impedance for the measuring instrument.
- b. Both lines of the power mains connected to the EUT were checked for maximum conducted interference.
- c. The frequency range from 150kHz to 30MHz was searched. Emission levels under (Limit - 20dB) was not recorded.

**NOTE:** All modes of operation were investigated and the worst-case emissions are reported.

#### 4.2.4 DEVIATION FROM TEST STANDARD

No deviation.

#### 4.2.5 TEST SETUP

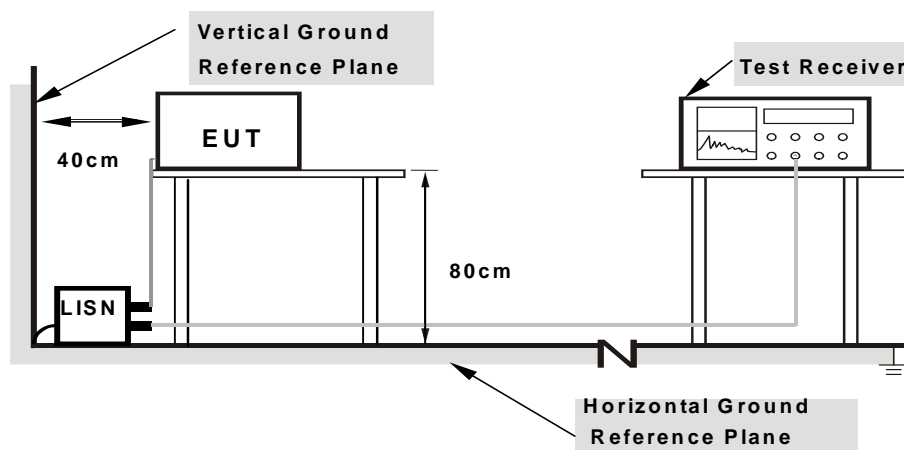

- Note:**
1. Support units were connected to second LISN.
  2. Both of LISNs (AMN) are 80 cm from EUT and at least 80 cm from other units and other metal planes

For the actual test configuration, please refer to the attached file (Test Setup Photo).

#### 4.2.6 EUT OPERATING CONDITIONS

Same as 4.1.6.

### 4.2.7 TEST RESULTS

#### CONDUCTED WORST-CASE DATA : 802.11n (20MHz)

PHASE	Line 1	6dB BANDWIDTH	9kHz
TEST MODE	A		

No	Freq. [MHz]	Corr. Factor (dB)	Reading Value		Emission Level		Limit		Margin	
			[dB (uV)]		[dB (uV)]		[dB (uV)]		(dB)	
			Q.P.	AV.	Q.P.	AV.	Q.P.	AV.	Q.P.	AV.
1	0.18125	0.12	50.10	39.31	50.22	39.43	64.43	54.43	-14.20	-14.99
2	0.36094	0.13	40.45	35.88	40.58	36.01	58.71	48.71	-18.13	-12.70
3	0.81016	0.17	35.22	25.66	35.39	25.83	56.00	46.00	-20.61	-20.17
4	1.88281	0.22	35.17	29.15	35.39	29.37	56.00	46.00	-20.61	-16.63
5	3.21094	0.29	31.54	26.58	31.83	26.87	56.00	46.00	-24.17	-19.13
6	7.62891	0.52	23.90	19.06	24.42	19.58	60.00	50.00	-35.58	-30.42

#### REMARKS:

1. Q.P. and AV. are abbreviations of quasi-peak and average individually.
2. The emission levels of other frequencies were very low against the limit.
3. Margin value = Emission level - Limit value
4. Correction factor = Insertion loss + Cable loss
5. Emission Level = Correction Factor + Reading Value.

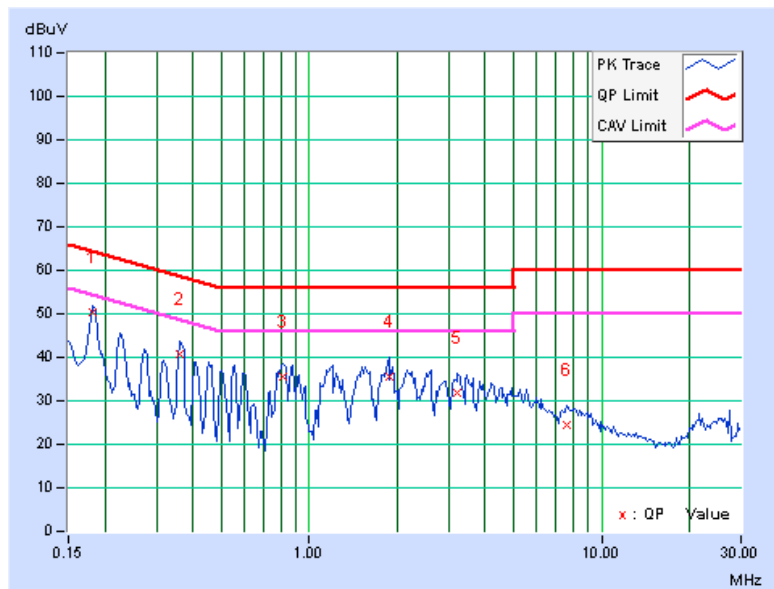

PHASE	Line 2	6dB BANDWIDTH	9kHz
TEST MODE	A		

No	Freq. [MHz]	Corr. Factor (dB)	Reading Value		Emission Level		Limit		Margin	
			[dB (uV)]		[dB (uV)]		[dB (uV)]		(dB)	
			Q.P.	AV.	Q.P.	AV.	Q.P.	AV.	Q.P.	AV.
1	0.18125	0.13	49.15	38.36	49.28	38.49	64.43	54.43	-15.14	-15.93
2	<b>0.36484</b>	<b>0.15</b>	<b>42.10</b>	<b>39.84</b>	<b>42.25</b>	<b>39.99</b>	<b>58.62</b>	<b>48.62</b>	<b>-16.37</b>	<b>-8.63</b>
3	1.19141	0.21	36.16	31.64	36.37	31.85	56.00	46.00	-19.63	-14.15
4	1.88281	0.23	35.63	29.49	35.86	29.72	56.00	46.00	-20.14	-16.28
5	8.08984	0.51	20.68	15.42	21.19	15.93	60.00	50.00	-38.81	-34.07
6	21.59375	1.03	22.29	15.54	23.32	16.57	60.00	50.00	-36.68	-33.43

**REMARKS:**

1. Q.P. and AV. are abbreviations of quasi-peak and average individually.
2. The emission levels of other frequencies were very low against the limit.
3. Margin value = Emission level - Limit value
4. Correction factor = Insertion loss + Cable loss
5. Emission Level = Correction Factor + Reading Value.

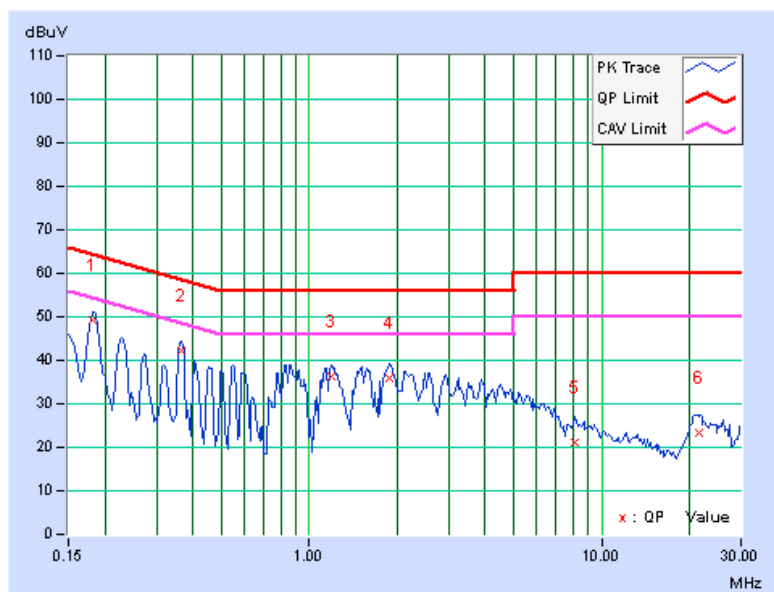

PHASE	Line 1	6dB BANDWIDTH	9kHz
TEST MODE	B		

No	Freq. [MHz]	Corr. Factor (dB)	Reading Value		Emission Level		Limit		Margin	
			[dB (uV)]		[dB (uV)]		[dB (uV)]		(dB)	
			Q.P.	AV.	Q.P.	AV.	Q.P.	AV.	Q.P.	AV.
1	0.16172	0.12	43.79	34.81	43.91	34.93	65.38	55.38	-21.47	-20.45
2	0.19297	0.13	37.85	28.45	37.98	28.58	63.91	53.91	-25.93	-25.33
3	0.48984	0.14	33.54	32.90	33.68	33.04	56.17	46.17	-22.49	-13.13
4	0.91953	0.18	25.11	23.21	25.29	23.39	56.00	46.00	-30.71	-22.61
5	3.63281	0.32	27.33	20.77	27.65	21.09	56.00	46.00	-28.35	-24.91
6	22.71094	1.30	36.33	30.83	37.63	32.13	60.00	50.00	-22.37	-17.87

**REMARKS:**

1. Q.P. and AV. are abbreviations of quasi-peak and average individually.
2. The emission levels of other frequencies were very low against the limit.
3. Margin value = Emission level - Limit value
4. Correction factor = Insertion loss + Cable loss
5. Emission Level = Correction Factor + Reading Value.

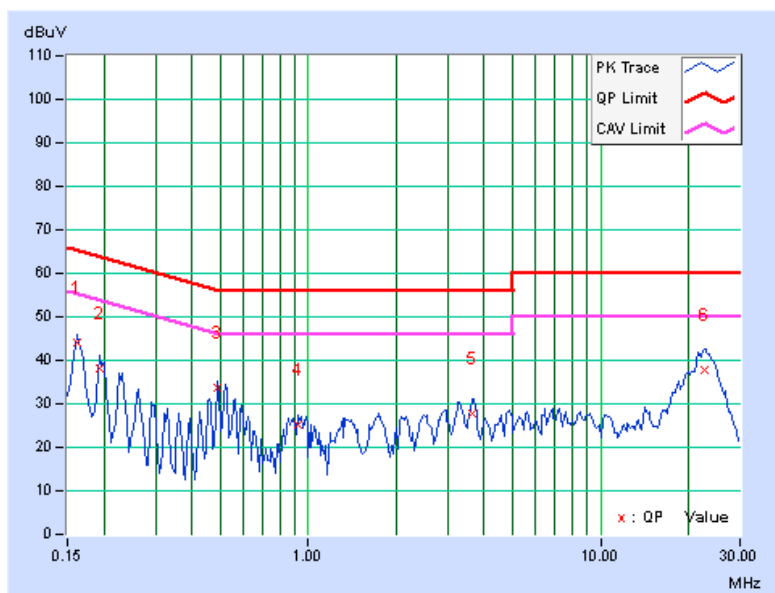





A D T

PHASE	Line 2	6dB BANDWIDTH	9kHz
TEST MODE	B		

No	Freq. [MHz]	Corr. Factor (dB)	Reading Value		Emission Level		Limit		Margin	
			[dB (uV)]		[dB (uV)]		[dB (uV)]		(dB)	
			Q.P.	AV.	Q.P.	AV.	Q.P.	AV.	Q.P.	AV.
1	0.16172	0.13	43.25	33.47	43.38	33.60	65.38	55.38	-22.00	-21.78
2	0.19687	0.14	39.48	29.47	39.62	29.61	63.74	53.74	-24.12	-24.13
3	0.49375	0.16	33.55	32.97	33.71	33.13	56.10	46.10	-22.40	-12.98
4	1.37891	0.22	22.97	19.45	23.19	19.67	56.00	46.00	-32.81	-26.33
5	3.65625	0.33	25.63	18.95	25.96	19.28	56.00	46.00	-30.04	-26.72
6	22.95313	1.07	35.82	30.20	36.89	31.27	60.00	50.00	-23.11	-18.73

**REMARKS:**

1. Q.P. and AV. are abbreviations of quasi-peak and average individually.
2. The emission levels of other frequencies were very low against the limit.
3. Margin value = Emission level - Limit value
4. Correction factor = Insertion loss + Cable loss
5. Emission Level = Correction Factor + Reading Value.

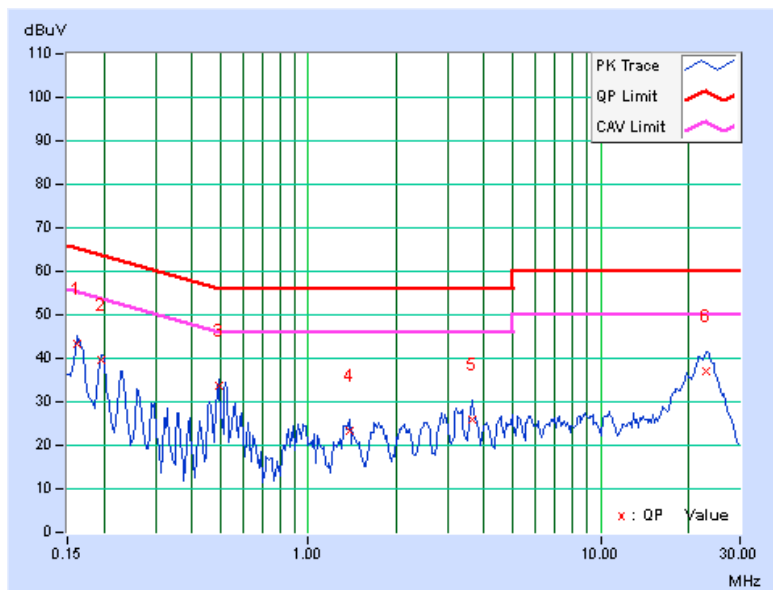

### 4.3 6dB BANDWIDTH MEASUREMENT

#### 4.3.1 LIMITS OF 6dB BANDWIDTH MEASUREMENT

The minimum of 6dB Bandwidth Measurement is 0.5 MHz.

#### 4.3.2 TEST SETUP

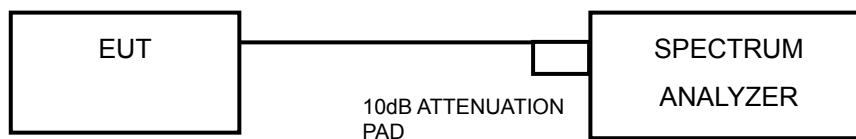

#### 4.3.3 TEST INSTRUMENTS

Refer to section 4.1.2 to get information of above instrument.

#### 4.3.4 TEST PROCEDURE

- a. Set resolution bandwidth (RBW) = approximately 1% of the emission bandwidth
- b. Set the video bandwidth (VBW)  $\geq 3 \times$  RBW, Detector = Peak.
- c. Trace mode = max hold.
- d. Sweep = auto couple.
- e. Measure the maximum width of the emission that is constrained by the frequencies associated with the two amplitude points (upper and lower) that are attenuated by 6 dB relative to the maximum level measured in the fundamental emission

#### 4.3.5 DEVIATION FROM TEST STANDARD

No deviation.

#### 4.3.6 EUT OPERATING CONDITIONS

The software provided by client to enable the EUT under transmission condition continuously at lowest, middle and highest channel frequencies individually.

#### 4.3.7 TEST RESULTS

##### 802.11b

CHANNEL	FREQUENCY (MHz)	6dB BANDWIDTH (MHz)	MINIMUM LIMIT (MHz)	PASS / FAIL
1	2412	8.12	0.5	PASS
6	2437	8.12	0.5	PASS
11	2462	8.14	0.5	PASS

##### 802.11g

CHANNEL	FREQUENCY (MHz)	6dB BANDWIDTH (MHz)		MINIMUM LIMIT (MHz)	PASS / FAIL
		CHAIN 0	CHAIN 1		
1	2412	16.53	16.52	0.5	PASS
6	2437	16.63	16.64	0.5	PASS
11	2462	16.53	16.53	0.5	PASS

##### 802.11n (20MHz)

CHANNEL	FREQUENCY (MHz)	6dB BANDWIDTH (MHz)		MINIMUM LIMIT (MHz)	PASS / FAIL
		CHAIN 0	CHAIN 1		
1	2412	17.76	17.76	0.5	PASS
6	2437	17.76	17.74	0.5	PASS
11	2462	17.74	17.78	0.5	PASS

##### 802.11n (40MHz)

CHANNEL	FREQUENCY (MHz)	6dB BANDWIDTH (MHz)		MINIMUM LIMIT (MHz)	PASS / FAIL
		CHAIN 0	CHAIN 1		
3	2422	36.59	36.27	0.5	PASS
6	2437	36.54	36.58	0.5	PASS
9	2452	36.50	36.53	0.5	PASS

## 4.4 CONDUCTED OUTPUT POWER

### 4.4.1 LIMITS OF CONDUCTED OUTPUT POWER MEASUREMENT

For systems using digital modulation in the 2400–2483.5 MHz bands: 1 Watt (30dBm)

### 4.4.2 TEST SETUP

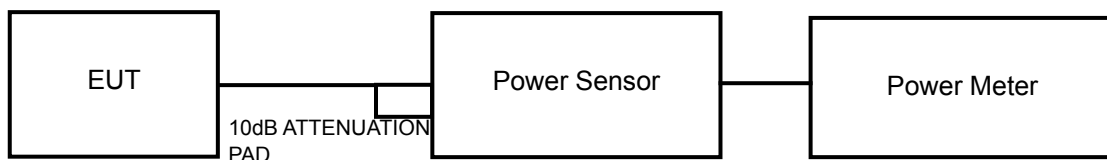

### 4.4.3 TEST INSTRUMENTS

Refer to section 4.1.2 to get information of above instrument.

### 4.4.4 TEST PROCEDURES

A peak power sensor was used on the output port of the EUT. A power meter was used to read the response of the peak power sensor. Record the peak power level.

### 4.4.5 DEVIATION FROM TEST STANDARD

No deviation.

### 4.4.6 EUT OPERATING CONDITIONS

Same as Item 4.3.6.

#### 4.4.7 TEST RESULTS

##### 802.11b

CHANNEL	FREQUENCY (MHz)	PEAK POWER (mW)	PEAK POWER (dBm)	LIMIT (dBm)	PASS/FAIL
1	2412	119.1	20.76	30	PASS
6	2437	118.3	20.73	30	PASS
11	2462	121.1	20.83	30	PASS

##### 802.11g

CHAN.	FREQUENCY (MHz)	PEAK POWER (dBm)		TOTAL POWER (mW)	TOTAL POWER (dBm)	LIMIT (dBm)	PASS / FAIL
		CHAIN 0	CHAIN 1				
1	2412	22.78	22.21	356.0	25.51	29	PASS
6	2437	24.12	24.05	512.3	27.10	29	PASS
11	2462	23.12	22.32	375.7	25.75	29	PASS

**NOTE:** Directional gain = 4dBi + 10log(2) = 7dBi > 6dBi , so the limit shall be reduced to 30-(7-6) = 29dBm.

##### 802.11n (20MHz)

CHAN.	FREQUENCY (MHz)	PEAK POWER (dBm)		TOTAL POWER (mW)	TOTAL POWER (dBm)	LIMIT (dBm)	PASS / FAIL
		CHAIN 0	CHAIN 1				
1	2412	20.71	21.67	264.7	24.23	29	PASS
6	2437	24.03	24.07	508.2	27.06	29	PASS
11	2462	21.98	22.28	326.8	25.14	29	PASS

**NOTE:** Directional gain = 4dBi + 10log(2) = 7dBi > 6dBi , so the limit shall be reduced to 30-(7-6) = 29dBm.

##### 802.11n (40MHz)

CHAN.	FREQUENCY (MHz)	PEAK POWER (dBm)		TOTAL POWER (mW)	TOTAL POWER (dBm)	LIMIT (dBm)	PASS / FAIL
		CHAIN 0	CHAIN 1				
3	2422	18.12	19.32	150.4	21.77	29	PASS
6	2437	20.42	22.62	293.0	24.67	29	PASS
9	2452	17.92	19.02	141.7	21.52	29	PASS

**NOTE:** Directional gain = 4dBi + 10log(2) = 7dBi > 6dBi , so the limit shall be reduced to 30-(7-6) = 29dBm.

## 4.5 POWER SPECTRAL DENSITY MEASUREMENT

### 4.5.1 LIMITS OF POWER SPECTRAL DENSITY MEASUREMENT

The Maximum of Power Spectral Density Measurement is 8dBm.

### 4.5.2 TEST SETUP

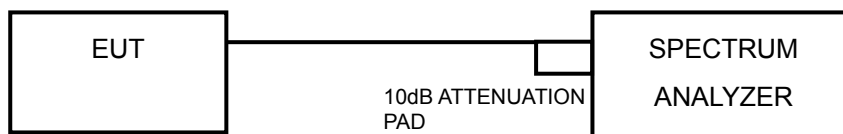

### 4.5.3 TEST INSTRUMENTS

Refer to section 4.1.2 to get information of above instrument.

### 4.5.4 TEST PROCEDURE

- a. Set the RBW = 100 kHz, VBW = 300 kHz, Detector = peak.
- b. Sweep time = auto couple, Trace mode = max hold, allow trace to fully stabilize.
- c. Use the peak marker function to determine the maximum power level in any 100 kHz band segment within the fundamental EBW.
- d. Scale the observed power level to an equivalent value in 3 kHz by adjusting (reducing) the measured power by a bandwidth correction factor (BWCF) where  $BWCF = 10\log(3 \text{ kHz}/100\text{kHz})$

### 4.5.5 DEVIATION FROM TEST STANDARD

No deviation.

### 4.5.6 EUT OPERATING CONDITION

Same as Item 4.3.6

## 4.5.7 TEST RESULTS

### 802.11b

Channel	FREQ. (MHz)	PSD (dBm/100kHz)	PSD (dBm/3kHz)	Limit (dBm/3kHz)	PASS /FAIL
1	2412	8.90	-6.33	8	PASS
6	2437	8.66	-6.57	8	PASS
11	2462	8.72	-6.51	8	PASS

### 802.11g

TX chain	Channel	FREQ. (MHz)	PSD (dBm/100kHz)	PSD (dBm/3kHz)	10 log (N=2) dB	Total PSD (dBm/3kHz)	Limit (dBm/3kHz)	PASS /FAIL
0	1	2412	2.11	-13.12	3.01	-10.11	7	PASS
	6	2437	3.70	-11.53	3.01	-8.52	7	PASS
	11	2462	2.45	-12.78	3.01	-9.77	7	PASS
1	1	2412	2.21	-13.02	3.01	-10.01	7	PASS
	6	2437	4.21	-11.02	3.01	-8.01	7	PASS
	11	2462	2.24	-12.99	3.01	-9.98	7	PASS

**NOTE:** Directional gain =  $4\text{dBi} + 10\log(2) = 7\text{dBi} > 6\text{dBi}$ , so the limit shall be reduced to  $8-(7-6) = 7\text{dBm}$ .

### 802.11n (20MHz)

TX chain	Channel	FREQ. (MHz)	PSD (dBm/100kHz)	PSD (dBm/3kHz)	10 log (N=2) dB	Total PSD (dBm/3kHz)	Limit (dBm/3kHz)	PASS /FAIL
0	1	2412	1.25	-13.98	3.01	-10.97	7	PASS
	6	2437	4.54	-10.69	3.01	-7.68	7	PASS
	11	2462	2.33	-12.9	3.01	-9.89	7	PASS
1	1	2412	1.56	-13.67	3.01	-10.66	7	PASS
	6	2437	4.14	-11.09	3.01	-8.08	7	PASS
	11	2462	2.21	-13.02	3.01	-10.01	7	PASS

**NOTE:** Directional gain =  $4\text{dBi} + 10\log(2) = 7\text{dBi} > 6\text{dBi}$ , so the limit shall be reduced to  $8-(7-6) = 7\text{dBm}$ .

### 802.11n (40MHz)

TX chain	Channel	FREQ. (MHz)	PSD (dBm/100kHz)	PSD (dBm/3kHz)	10 log (N=2) dB	Total PSD (dBm/3kHz)	Limit (dBm/3kHz)	PASS /FAIL
0	3	2422	-5.56	-20.79	3.01	-17.78	7	PASS
	6	2437	-3.20	-18.43	3.01	-15.42	7	PASS
	9	2452	-5.64	-20.87	3.01	-17.86	7	PASS
1	3	2422	-3.59	-18.82	3.01	-15.81	7	PASS
	6	2437	-0.25	-15.48	3.01	-12.47	7	PASS
	9	2452	-3.75	-18.98	3.01	-15.97	7	PASS

**NOTE:** Directional gain =  $4\text{dBi} + 10\log(2) = 7\text{dBi} > 6\text{dBi}$ , so the limit shall be reduced to  $8-(7-6) = 7\text{dBm}$ .

## 4.6 CONDUCTED OUT OF BAND EMISSION MEASUREMENT

### 4.6.1 LIMITS OF CONDUCTED OUT OF BAND EMISSION MEASUREMENT

Below  $-20\text{dB}$  of the highest emission level of operating band (in 100kHz Resolution Bandwidth).

### 4.6.2 TEST SETUP

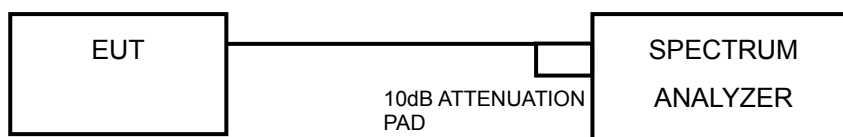

### 4.6.3 TEST INSTRUMENTS

Refer to section 4.1.2 to get information of above instrument.

### 4.6.4 TEST PROCEDURE

#### MEASUREMENT PROCEDURE REF

1. Set the RBW = 100 kHz.
2. Set the VBW  $\geq$  300 kHz.
3. Detector = peak.
4. Sweep time = auto couple.
5. Trace mode = max hold.
6. Allow trace to fully stabilize.
7. Use the peak marker function to determine the maximum power level in any 100 kHz band segment within the fundamental EBW.



## MEASUREMENT PROCEDURE OOB

1. Set RBW = 100 kHz.
2. Set VBW  $\geq$  300 kHz.
3. Set span to encompass the spectrum to be examined.
4. Detector = peak.
5. Trace Mode = max hold.
6. Sweep = auto couple.

### 4.6.5 DEVIATION FROM TEST STANDARD

No deviation.

### 4.6.6 EUT OPERATING CONDITION

Same as Item 4.3.6

### 4.6.7 TEST RESULTS

The conducted emission test is performed on each TX port of operating mode without summing or adding  $10\log(N)$  since the limit is relative emission limit. Only worst data of each operating mode is presented.

The spectrum plots are attached on the following pages. D1 line indicates the highest level, and D2 line indicates the 20dB offset below D1. It shows compliance with the requirement.



## 4.6.8 TEST RESULTS

### 802.11b

#### CH 1

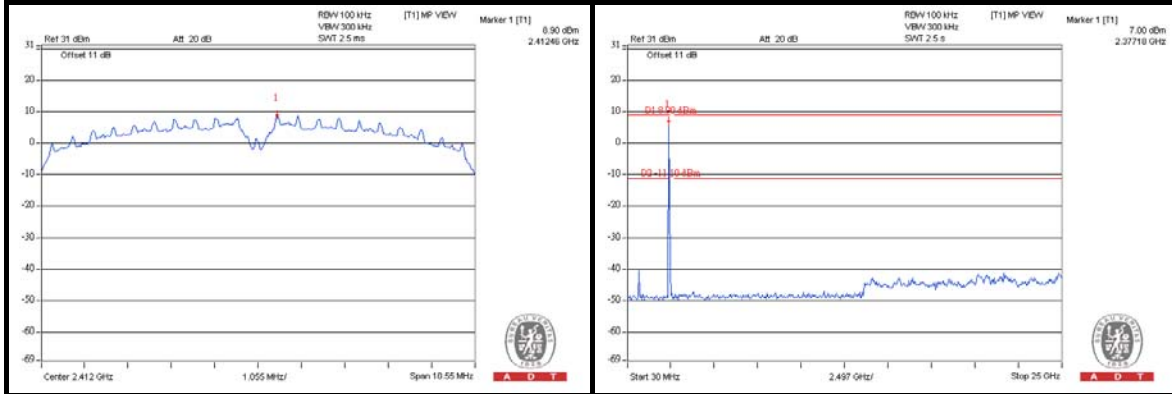

#### CH 6

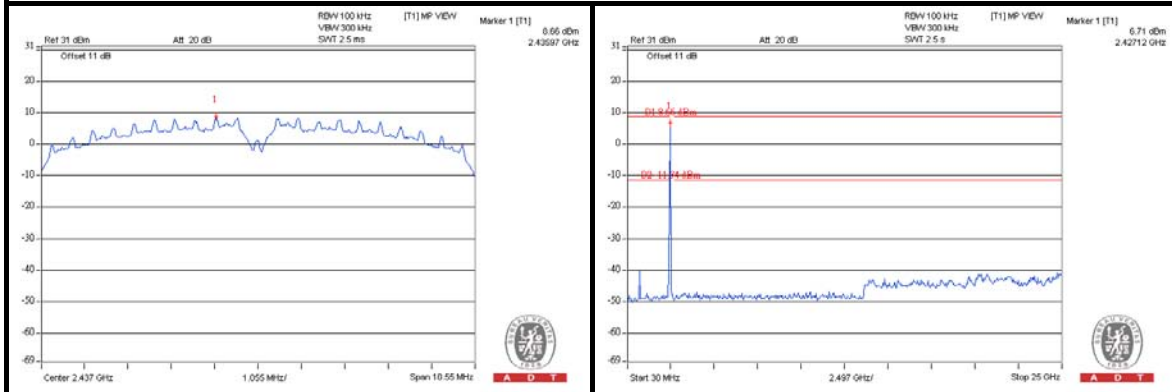

#### CH 11

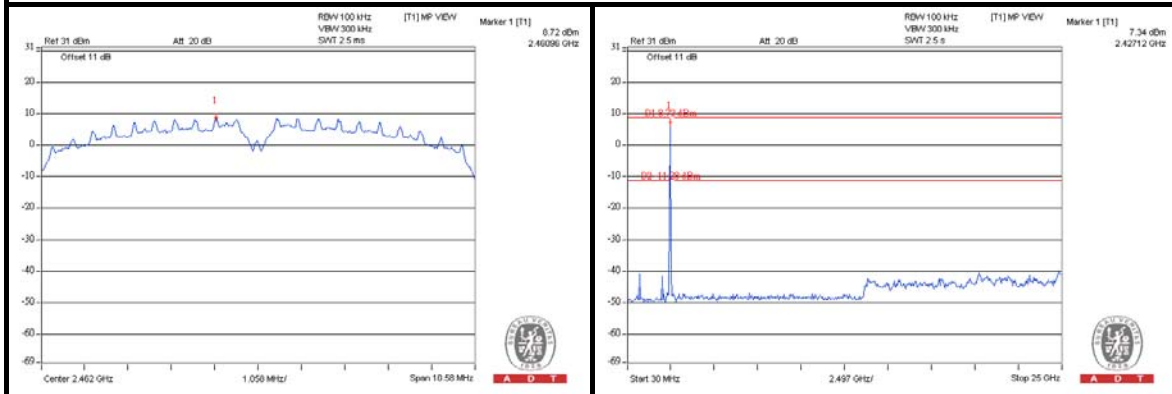



A D T

## 802.11g

### CH 1

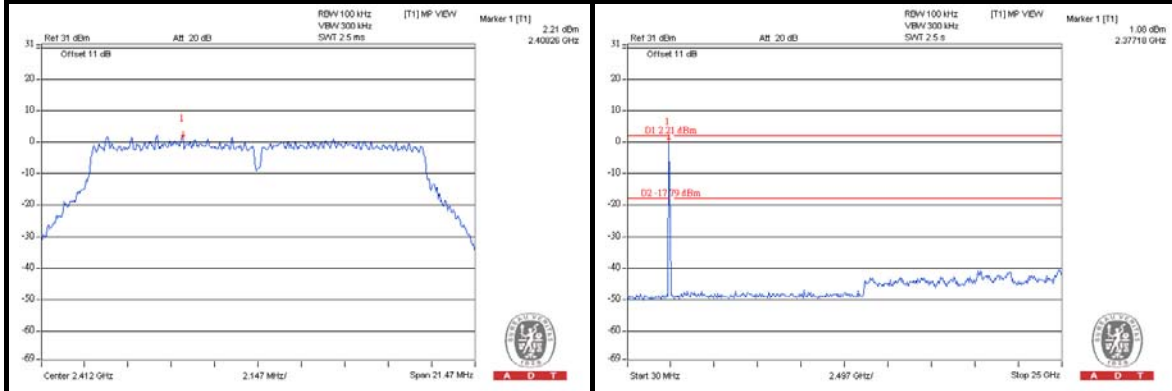

### CH 6

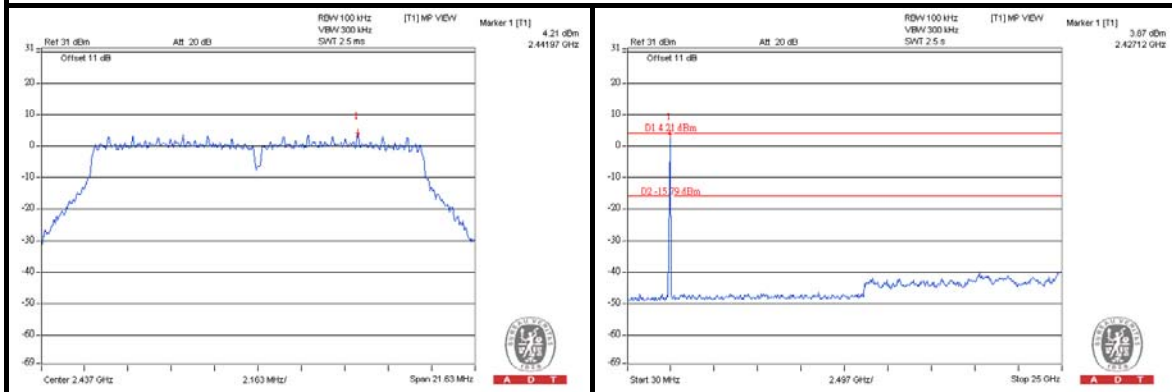

### CH 11

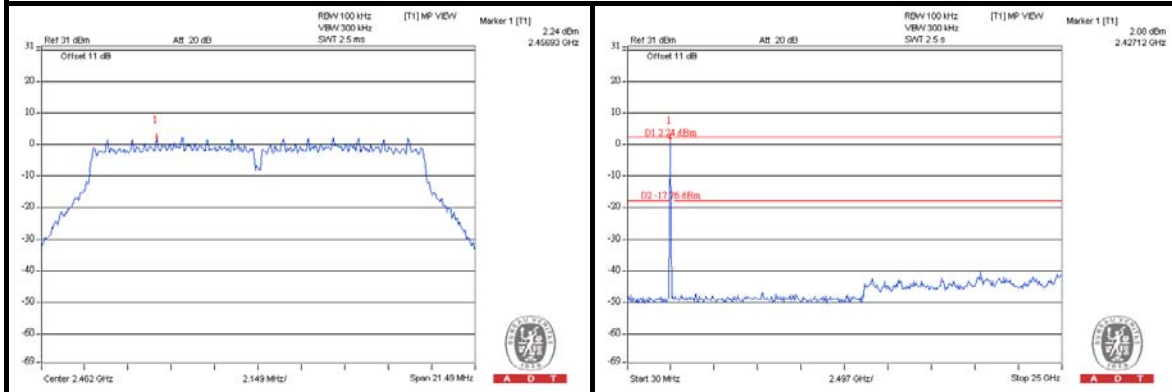



A D T

### 802.11n (20MHz)

#### CH 1

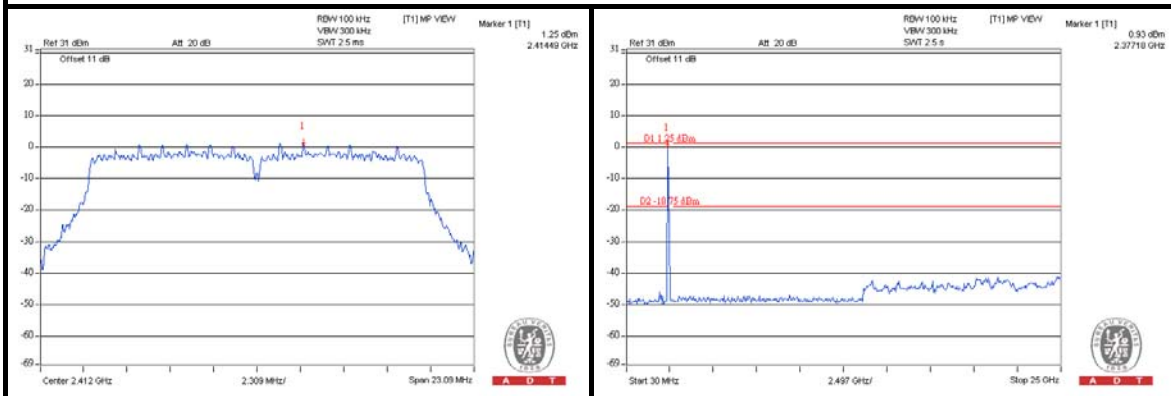

#### CH 6

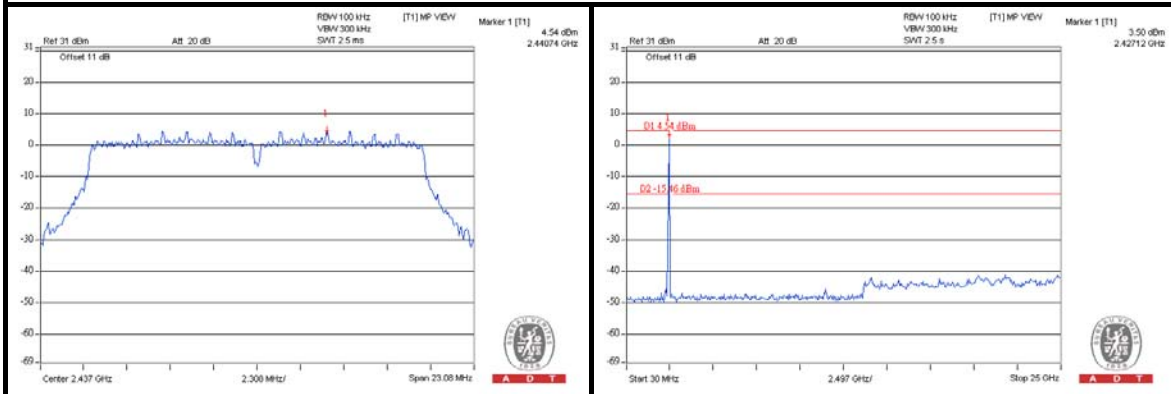

#### CH 11

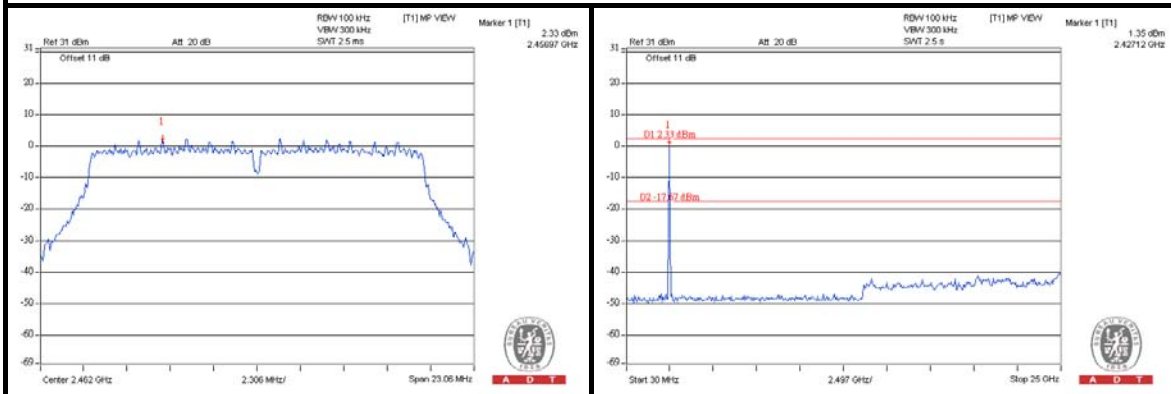



A D T

### 802.11n (40MHz)

#### CH 3

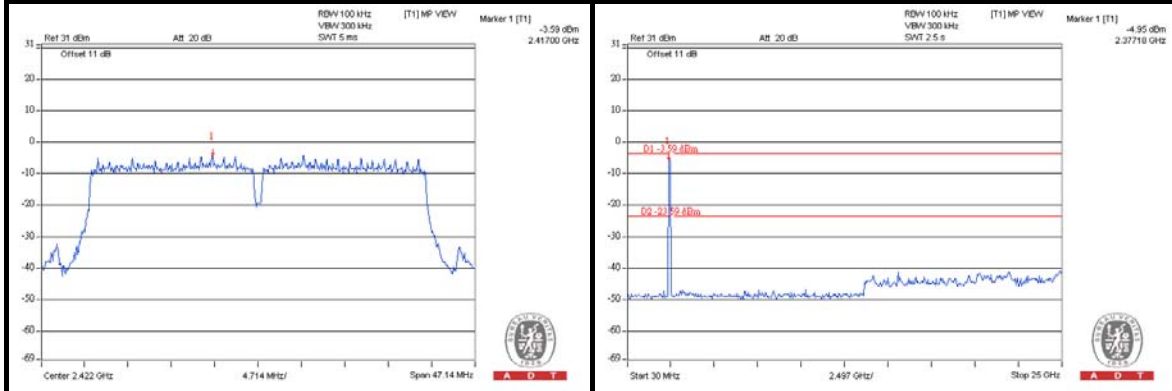

#### CH 6

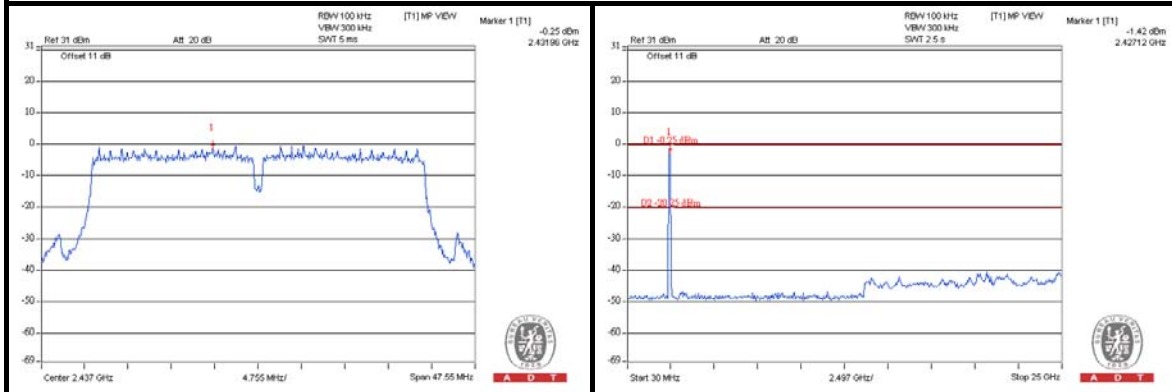

#### CH 9

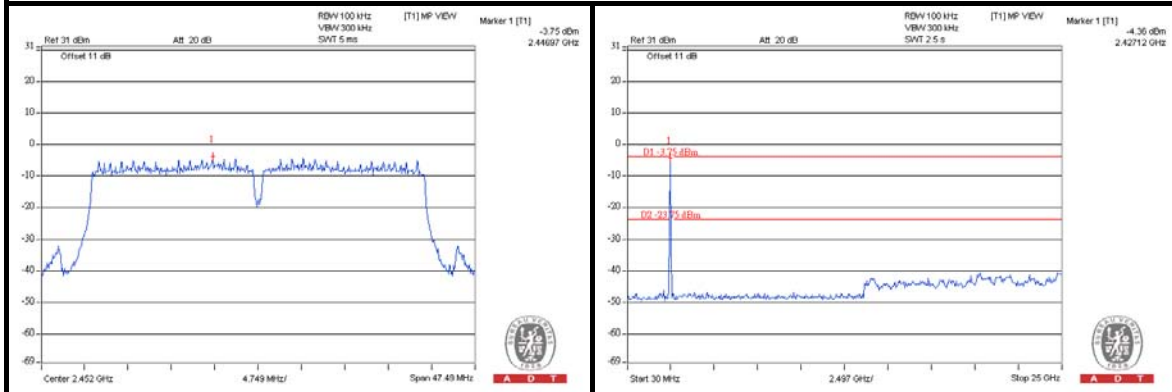

## 5. TEST TYPES AND RESULTS (FOR 5.0GHz BAND)

### 5.1 RADIATED EMISSION MEASUREMENT

#### 5.1.1 LIMITS OF RADIATED EMISSION MEASUREMENT

Radiated emissions which fall in the restricted bands must comply with the radiated emission limits specified as below table. Other emissions shall be at least 20dB below the highest level of the desired power:

FREQUENCIES (MHz)	FIELD STRENGTH (microvolts/meter)	MEASUREMENT DISTANCE (meters)
0.009 ~ 0.490	2400/F(kHz)	300
0.490 ~ 1.705	24000/F(kHz)	30
1.705 ~ 30.0	30	30
30 ~ 88	100	3
88 ~ 216	150	3
216 ~ 960	200	3
Above 960	500	3

**NOTE:**

1. The lower limit shall apply at the transition frequencies.
2. Emission level (dBuV/m) = 20 log Emission level (uV/m).
3. For frequencies above 1000MHz, the field strength limits are based on average detector, however, the peak field strength of any emission shall not exceed the maximum permitted average limits, specified above by more than 20dB under any condition of modulation.

### 5.1.2 TEST INSTRUMENTS

Same as item 4.1.2.

### 5.1.3 TEST PROCEDURES

Same as item 4.1.3.

### 5.1.4 DEVIATION FROM TEST STANDARD

No deviation.

### 5.1.5 TEST SETUP

Same as item 4.1.5.

### 5.1.6 EUT OPERATING CONDITIONS

Same as 4.1.6.

### 5.1.7 TEST RESULTS

#### ABOVE 1GHZ DATA: 802.11a

EUT TEST CONDITION		MEASUREMENT DETAIL	
CHANNEL	Channel 149	FREQUENCY RANGE	1 ~ 40GHz
INPUT POWER (SYSTEM)	120Vac, 60 Hz	DETECTOR FUNCTION	Peak (PK) Average (AV)
ENVIRONMENTAL CONDITIONS	22deg. C, 70%RH	TESTED BY	Sun Lin

ANTENNA POLARITY & TEST DISTANCE: HORIZONTAL AT 3 M								
NO.	FREQ. (MHz)	EMISSION LEVEL (dBuV/m)	LIMIT (dBuV/m)	MARGIN (dB)	ANTENNA HEIGHT (m)	TABLE ANGLE (Degree)	RAW VALUE (dBuV)	CORRECTION FACTOR (dB/m)
1	5424.00	54.5 PK	74.0	-19.5	1.00 H	98	15.90	38.60
2	5424.00	42.6 AV	54.0	-11.4	1.00 H	98	4.00	38.60
3	#5725.00	70.3 PK	80.8	-10.5	1.00 H	98	31.10	39.20
4	#5725.00	51.1 AV	71.5	-20.4	1.00 H	98	11.90	39.20
5	*5745.00	100.8 PK			1.00 H	98	61.50	39.30
6	*5745.00	91.5 AV			1.00 H	98	52.20	39.30
7	11490.00	55.2 PK	74.0	-18.8	1.32 H	96	5.80	49.40
8	11490.00	43.7 AV	54.0	-10.3	1.32 H	96	-5.70	49.40
ANTENNA POLARITY & TEST DISTANCE: VERTICAL AT 3 M								
NO.	FREQ. (MHz)	EMISSION LEVEL (dBuV/m)	LIMIT (dBuV/m)	MARGIN (dB)	ANTENNA HEIGHT (m)	TABLE ANGLE (Degree)	RAW VALUE (dBuV)	CORRECTION FACTOR (dB/m)
1	5424.00	58.6 PK	74.0	-15.4	1.21 V	348	20.00	38.60
2	5424.00	46.4 AV	54.0	-7.6	1.21 V	348	7.80	38.60
3	#5725.00	80.3 PK	92.5	-12.2	1.00 V	75	41.10	39.20
4	#5725.00	60.7 AV	82.9	-22.2	1.00 V	75	21.50	39.20
5	*5745.00	112.5 PK			1.00 V	72	73.20	39.30
6	*5745.00	102.9 AV			1.00 V	72	63.60	39.30
7	11490.00	57.5 PK	74.0	-16.5	1.21 V	189	8.10	49.40
8	11490.00	45.3 AV	54.0	-8.7	1.21 V	189	-4.10	49.40

#### REMARKS:

1. Emission level (dBuV/m) = Raw Value (dBuV) + Correction Factor (dB/m).
2. Correction Factor (dB/m) = Antenna Factor (dB/m) + Cable Factor (dB).
3. The other emission levels were very low against the limit.
4. Margin value = Emission level – Limit value.
5. “ \* “: Fundamental frequency.
6. The limit value is defined as per 15.247.
7. "#":The radiated frequency is out the restricted band.



EUT TEST CONDITION		MEASUREMENT DETAIL	
CHANNEL	Channel 157	FREQUENCY RANGE	1 ~ 40GHz
INPUT POWER (SYSTEM)	120Vac, 60 Hz	DETECTOR FUNCTION	Peak (PK) Average (AV)
ENVIRONMENTAL CONDITIONS	22deg. C, 70%RH	TESTED BY	Sun Lin

ANTENNA POLARITY & TEST DISTANCE: HORIZONTAL AT 3 M								
NO.	FREQ. (MHz)	EMISSION LEVEL (dBuV/m)	LIMIT (dBuV/m)	MARGIN (dB)	ANTENNA HEIGHT (m)	TABLE ANGLE (Degree)	RAW VALUE (dBuV)	CORRECTION FACTOR (dB/m)
1	*5785.00	100.1 PK			1.02 H	102	60.70	39.40
2	*5785.00	90.9 AV			1.02 H	102	51.50	39.40
3	7713.00	52.7 PK	74.0	-21.3	1.18 H	217	8.20	44.50
4	7713.00	40.7 AV	54.0	-13.3	1.18 H	217	-3.80	44.50
5	11570.00	55.4 PK	74.0	-18.6	1.02 H	186	6.20	49.20
6	11570.00	45.2 AV	54.0	-8.8	1.02 H	186	-4.00	49.20
ANTENNA POLARITY & TEST DISTANCE: VERTICAL AT 3 M								
NO.	FREQ. (MHz)	EMISSION LEVEL (dBuV/m)	LIMIT (dBuV/m)	MARGIN (dB)	ANTENNA HEIGHT (m)	TABLE ANGLE (Degree)	RAW VALUE (dBuV)	CORRECTION FACTOR (dB/m)
1	*5785.00	112.0 PK			1.00 V	72	72.60	39.40
2	*5785.00	102.1 AV			1.00 V	72	62.70	39.40
3	7713.00	52.4 PK	74.0	-21.6	1.05 V	89	7.90	44.50
4	7713.00	41.4 AV	54.0	-12.6	1.05 V	89	-3.10	44.50
5	11570.00	56.9 PK	74.0	-17.1	1.32 V	202	7.70	49.20
6	11570.00	45.9 AV	54.0	-8.1	1.32 V	202	-3.30	49.20

**REMARKS:**

1. Emission level (dBuV/m) = Raw Value (dBuV) + Correction Factor (dB/m).
2. Correction Factor (dB/m) = Antenna Factor (dB/m) + Cable Factor (dB).
3. The other emission levels were very low against the limit.
4. Margin value = Emission level – Limit value.
5. “ \* “: Fundamental frequency.
6. The limit value is defined as per 15.247.

EUT TEST CONDITION		MEASUREMENT DETAIL	
CHANNEL	Channel 165	FREQUENCY RANGE	1 ~ 40GHz
INPUT POWER (SYSTEM)	120Vac, 60 Hz	DETECTOR FUNCTION	Peak (PK) Average (AV)
ENVIRONMENTAL CONDITIONS	22deg. C, 70%RH	TESTED BY	Sun Lin

ANTENNA POLARITY & TEST DISTANCE: HORIZONTAL AT 3 M								
NO.	FREQ. (MHz)	EMISSION LEVEL (dBuV/m)	LIMIT (dBuV/m)	MARGIN (dB)	ANTENNA HEIGHT (m)	TABLE ANGLE (Degree)	RAW VALUE (dBuV)	CORRECTION FACTOR (dB/m)
1	*5825.00	100.3 PK			1.02 H	102	60.80	39.50
2	*5825.00	91.0 AV			1.02 H	102	51.50	39.50
3	#5850.00	63.1 PK	80.3	-17.2	1.02 H	102	23.60	39.50
4	#5850.00	45.2 AV	71.0	-25.8	1.02 H	102	5.70	39.50
5	11650.00	55.6 PK	74.0	-18.4	1.35 H	107	6.50	49.10
6	11650.00	43.9 AV	54.0	-10.1	1.35 H	107	-5.20	49.10
ANTENNA POLARITY & TEST DISTANCE: VERTICAL AT 3 M								
NO.	FREQ. (MHz)	EMISSION LEVEL (dBuV/m)	LIMIT (dBuV/m)	MARGIN (dB)	ANTENNA HEIGHT (m)	TABLE ANGLE (Degree)	RAW VALUE (dBuV)	CORRECTION FACTOR (dB/m)
1	*5825.00	112.2 PK			1.00 V	85	72.70	39.50
2	*5825.00	102.1 AV			1.00 V	85	62.60	39.50
3	#5850.00	72.6 PK	92.2	-19.6	1.00 V	69	33.10	39.50
4	#5850.00	55.3 AV	82.1	-26.8	1.00 V	69	15.80	39.50
5	11650.00	57.1 PK	74.0	-16.9	1.23 V	207	8.00	49.10
6	11650.00	44.8 AV	54.0	-9.2	1.23 V	207	-4.30	49.10

**REMARKS:**

1. Emission level (dBuV/m) = Raw Value (dBuV) + Correction Factor (dB/m).
2. Correction Factor (dB/m) = Antenna Factor (dB/m) + Cable Factor (dB).
3. The other emission levels were very low against the limit.
4. Margin value = Emission level – Limit value.
5. “ \* “: Fundamental frequency.
6. The limit value is defined as per 15.247.
7. “#”:The radiated frequency is out the restricted band.

802.11n (20MHz)

EUT TEST CONDITION		MEASUREMENT DETAIL	
CHANNEL	Channel 149	FREQUENCY RANGE	1 ~ 40GHz
INPUT POWER (SYSTEM)	120Vac, 60 Hz	DETECTOR FUNCTION	Peak (PK) Average (AV)
ENVIRONMENTAL CONDITIONS	22deg. C, 70%RH	TESTED BY	Sun Lin

ANTENNA POLARITY & TEST DISTANCE: HORIZONTAL AT 3 M								
NO.	FREQ. (MHz)	EMISSION LEVEL (dBuV/m)	LIMIT (dBuV/m)	MARGIN (dB)	ANTENNA HEIGHT (m)	TABLE ANGLE (Degree)	RAW VALUE (dBuV)	CORRECTION FACTOR (dB/m)
1	5424.00	54.8 PK	74.0	-19.2	1.08 H	117	16.20	38.60
2	5424.00	42.8 AV	54.0	-11.2	1.08 H	117	4.20	38.60
3	#5725.00	70.1 PK	79.2	-9.1	1.00 H	105	30.90	39.20
4	#5725.00	50.8 AV	70.1	-19.3	1.00 H	105	11.60	39.20
5	*5745.00	99.2 PK			1.00 H	102	59.90	39.30
6	*5745.00	90.1 AV			1.00 H	102	50.80	39.30
7	11490.00	55.7 PK	74.0	-18.3	1.35 H	104	6.30	49.40
8	11490.00	43.8 AV	54.0	-10.2	1.35 H	104	-5.60	49.40
ANTENNA POLARITY & TEST DISTANCE: VERTICAL AT 3 M								
NO.	FREQ. (MHz)	EMISSION LEVEL (dBuV/m)	LIMIT (dBuV/m)	MARGIN (dB)	ANTENNA HEIGHT (m)	TABLE ANGLE (Degree)	RAW VALUE (dBuV)	CORRECTION FACTOR (dB/m)
1	5424.00	58.8 PK	74.0	-15.2	1.23 V	341	20.20	38.60
2	5424.00	46.8 AV	54.0	-7.2	1.23 V	341	8.20	38.60
3	#5725.00	79.9 PK	91.0	-11.1	1.00 V	75	40.70	39.20
4	#5725.00	60.1 AV	80.5	-20.4	1.00 V	75	20.90	39.20
5	*5745.00	111.0 PK			1.00 V	75	71.70	39.30
6	*5745.00	100.5 AV			1.00 V	75	61.20	39.30
7	11490.00	57.2 PK	74.0	-16.8	1.18 V	199	7.80	49.40
8	11490.00	44.8 AV	54.0	-9.2	1.18 V	199	-4.60	49.40

REMARKS:

1. Emission level (dBuV/m) = Raw Value (dBuV) + Correction Factor (dB/m).
2. Correction Factor (dB/m) = Antenna Factor (dB/m) + Cable Factor (dB).
3. The other emission levels were very low against the limit.
4. Margin value = Emission level – Limit value.
5. “ \* “: Fundamental frequency.
6. The limit value is defined as per 15.247.
7. "#":The radiated frequency is out the restricted band.

EUT TEST CONDITION		MEASUREMENT DETAIL	
CHANNEL	Channel 157	FREQUENCY RANGE	1 ~ 40GHz
INPUT POWER (SYSTEM)	120Vac, 60 Hz	DETECTOR FUNCTION	Peak (PK) Average (AV)
ENVIRONMENTAL CONDITIONS	22deg. C, 70%RH	TESTED BY	Sun Lin

ANTENNA POLARITY & TEST DISTANCE: HORIZONTAL AT 3 M								
NO.	FREQ. (MHz)	EMISSION LEVEL (dBuV/m)	LIMIT (dBuV/m)	MARGIN (dB)	ANTENNA HEIGHT (m)	TABLE ANGLE (Degree)	RAW VALUE (dBuV)	CORRECTION FACTOR (dB/m)
1	*5785.00	98.6 PK			1.00 H	91	59.20	39.40
2	*5785.00	89.5 AV			1.00 H	91	50.10	39.40
3	7713.00	52.8 PK	74.0	-21.2	1.24 H	223	8.30	44.50
4	7713.00	40.5 AV	54.0	-13.5	1.24 H	223	-4.00	44.50
5	11570.00	55.2 PK	74.0	-18.8	1.00 H	196	6.00	49.20
6	11570.00	44.7 AV	54.0	-9.3	1.00 H	196	-4.50	49.20
ANTENNA POLARITY & TEST DISTANCE: VERTICAL AT 3 M								
NO.	FREQ. (MHz)	EMISSION LEVEL (dBuV/m)	LIMIT (dBuV/m)	MARGIN (dB)	ANTENNA HEIGHT (m)	TABLE ANGLE (Degree)	RAW VALUE (dBuV)	CORRECTION FACTOR (dB/m)
1	*5785.00	110.3 PK			1.00 V	78	70.90	39.40
2	*5785.00	100.0 AV			1.00 V	78	60.60	39.40
3	7713.00	52.7 PK	74.0	-21.3	1.08 V	92	8.20	44.50
4	7713.00	41.7 AV	54.0	-12.3	1.08 V	92	-2.80	44.50
5	11570.00	56.5 PK	74.0	-17.5	1.22 V	198	7.30	49.20
6	11570.00	45.3 AV	54.0	-8.7	1.22 V	198	-3.90	49.20

**REMARKS:**

1. Emission level (dBuV/m) = Raw Value (dBuV) + Correction Factor (dB/m).
2. Correction Factor (dB/m) = Antenna Factor (dB/m) + Cable Factor (dB).
3. The other emission levels were very low against the limit.
4. Margin value = Emission level – Limit value.
5. “ \* ”: Fundamental frequency.
6. The limit value is defined as per 15.247.

EUT TEST CONDITION		MEASUREMENT DETAIL	
CHANNEL	Channel 165	FREQUENCY RANGE	1 ~ 40GHz
INPUT POWER (SYSTEM)	120Vac, 60 Hz	DETECTOR FUNCTION	Peak (PK) Average (AV)
ENVIRONMENTAL CONDITIONS	22deg. C, 70%RH	TESTED BY	Sun Lin

ANTENNA POLARITY & TEST DISTANCE: HORIZONTAL AT 3 M								
NO.	FREQ. (MHz)	EMISSION LEVEL (dBuV/m)	LIMIT (dBuV/m)	MARGIN (dB)	ANTENNA HEIGHT (m)	TABLE ANGLE (Degree)	RAW VALUE (dBuV)	CORRECTION FACTOR (dB/m)
1	*5825.00	98.6 PK			1.00 H	98	59.10	39.50
2	*5825.00	89.5 AV			1.00 H	98	50.00	39.50
3	#5850.00	62.8 PK	78.6	-15.8	1.00 H	97	23.30	39.50
4	#5850.00	44.8 AV	69.5	-24.7	1.00 H	97	5.30	39.50
5	11650.00	55.2 PK	74.0	-18.8	1.22 H	85	6.10	49.10
6	11650.00	43.2 AV	54.0	-10.8	1.22 H	85	-5.90	49.10
ANTENNA POLARITY & TEST DISTANCE: VERTICAL AT 3 M								
NO.	FREQ. (MHz)	EMISSION LEVEL (dBuV/m)	LIMIT (dBuV/m)	MARGIN (dB)	ANTENNA HEIGHT (m)	TABLE ANGLE (Degree)	RAW VALUE (dBuV)	CORRECTION FACTOR (dB/m)
1	*5825.00	110.2 PK			1.00 V	73	70.70	39.50
2	*5825.00	100.0 AV			1.00 V	73	60.50	39.50
3	#5850.00	72.3 PK	90.2	-17.9	1.00 V	69	32.80	39.50
4	#5850.00	56.2 AV	80.0	-23.8	1.00 V	69	16.70	39.50
5	11650.00	57.5 PK	74.0	-16.5	1.14 V	205	8.40	49.10
6	11650.00	45.2 AV	54.0	-8.8	1.14 V	205	-3.90	49.10

**REMARKS:**

1. Emission level (dBuV/m) = Raw Value (dBuV) + Correction Factor (dB/m).
2. Correction Factor (dB/m) = Antenna Factor (dB/m) + Cable Factor (dB).
3. The other emission levels were very low against the limit.
4. Margin value = Emission level – Limit value.
5. “ \* “: Fundamental frequency.
6. The limit value is defined as per 15.247.
7. "#":The radiated frequency is out the restricted band.

802.11n (40MHz)

EUT TEST CONDITION		MEASUREMENT DETAIL	
CHANNEL	Channel 151	FREQUENCY RANGE	1 ~ 40GHz
INPUT POWER (SYSTEM)	120Vac, 60 Hz	DETECTOR FUNCTION	Peak (PK) Average (AV)
ENVIRONMENTAL CONDITIONS	22deg. C, 70%RH	TESTED BY	Sun Lin

ANTENNA POLARITY & TEST DISTANCE: HORIZONTAL AT 3 M								
NO.	FREQ. (MHz)	EMISSION LEVEL (dBuV/m)	LIMIT (dBuV/m)	MARGIN (dB)	ANTENNA HEIGHT (m)	TABLE ANGLE (Degree)	RAW VALUE (dBuV)	CORRECTION FACTOR (dB/m)
1	#5725.00	72.5 PK	77.2	-4.7	1.00 H	93	33.30	39.20
2	#5725.00	53.7 AV	68.0	-14.3	1.00 H	93	14.50	39.20
3	*5755.00	97.2 PK			1.00 H	93	57.90	39.30
4	*5755.00	88.0 AV			1.00 H	93	48.70	39.30
5	11510.00	54.7 PK	74.0	-19.3	1.34 H	108	5.30	49.40
6	11510.00	43.2 AV	54.0	-10.8	1.34 H	108	-6.20	49.40

ANTENNA POLARITY & TEST DISTANCE: VERTICAL AT 3 M								
NO.	FREQ. (MHz)	EMISSION LEVEL (dBuV/m)	LIMIT (dBuV/m)	MARGIN (dB)	ANTENNA HEIGHT (m)	TABLE ANGLE (Degree)	RAW VALUE (dBuV)	CORRECTION FACTOR (dB/m)
1	#5725.00	82.1 PK	88.7	-6.6	1.00 V	73	42.90	39.20
2	#5725.00	63.8 AV	79.4	-15.6	1.00 V	73	24.60	39.20
3	*5755.00	108.7 PK			1.00 V	71	69.40	39.30
4	*5755.00	99.4 AV			1.00 V	71	60.10	39.30
5	11510.00	57.2 PK	74.0	-16.8	1.18 V	204	7.80	49.40
6	11510.00	44.7 AV	54.0	-9.3	1.18 V	204	-4.70	49.40

REMARKS:

1. Emission level (dBuV/m) = Raw Value (dBuV) + Correction Factor (dB/m).
2. Correction Factor (dB/m) = Antenna Factor (dB/m) + Cable Factor (dB).
3. The other emission levels were very low against the limit.
4. Margin value = Emission level – Limit value.
5. “ \* “: Fundamental frequency.
6. The limit value is defined as per 15.247.
7. "#":The radiated frequency is out the restricted band.

EUT TEST CONDITION		MEASUREMENT DETAIL	
CHANNEL	Channel 159	FREQUENCY RANGE	1 ~ 40GHz
INPUT POWER (SYSTEM)	120Vac, 60 Hz	DETECTOR FUNCTION	Peak (PK) Average (AV)
ENVIRONMENTAL CONDITIONS	22deg. C, 70%RH	TESTED BY	Sun Lin

ANTENNA POLARITY & TEST DISTANCE: HORIZONTAL AT 3 M								
NO.	FREQ. (MHz)	EMISSION LEVEL (dBuV/m)	LIMIT (dBuV/m)	MARGIN (dB)	ANTENNA HEIGHT (m)	TABLE ANGLE (Degree)	RAW VALUE (dBuV)	CORRECTION FACTOR (dB/m)
1	*5795.00	96.8 PK			1.00 H	98	57.40	39.40
2	*5795.00	87.5 AV			1.00 H	98	48.10	39.40
3	#5850.00	60.8 PK	76.8	-16.0	1.00 H	98	21.30	39.50
4	#5850.00	45.2 AV	67.5	-22.3	1.00 H	98	5.70	39.50
5	11590.00	54.2 PK	74.0	-19.8	1.35 H	107	5.10	49.10
6	11590.00	42.8 AV	54.0	-11.2	1.35 H	107	-6.30	49.10
ANTENNA POLARITY & TEST DISTANCE: VERTICAL AT 3 M								
NO.	FREQ. (MHz)	EMISSION LEVEL (dBuV/m)	LIMIT (dBuV/m)	MARGIN (dB)	ANTENNA HEIGHT (m)	TABLE ANGLE (Degree)	RAW VALUE (dBuV)	CORRECTION FACTOR (dB/m)
1	*5795.00	108.5 PK			1.00 V	72	69.10	39.40
2	*5795.00	99.2 AV			1.00 V	72	59.80	39.40
3	#5850.00	69.0 PK	88.5	-19.5	1.00 V	67	29.50	39.50
4	#5850.00	54.5 AV	79.2	-24.7	1.00 V	67	15.00	39.50
5	11590.00	57.5 PK	74.0	-16.5	1.27 V	196	8.40	49.10
6	11590.00	48.2 AV	54.0	-5.8	1.27 V	196	-0.90	49.10

**REMARKS:**

1. Emission level (dBuV/m) = Raw Value (dBuV) + Correction Factor (dB/m).
2. Correction Factor (dB/m) = Antenna Factor (dB/m) + Cable Factor (dB).
3. The other emission levels were very low against the limit.
4. Margin value = Emission level – Limit value.
5. “ \* “: Fundamental frequency.
6. The limit value is defined as per 15.247.
7. "#":The radiated frequency is out the restricted band.

**BELOW 1GHz WORST-CASE DATA : 802.11a**

EUT TEST CONDITION		MEASUREMENT DETAIL	
CHANNEL	Channel 149	FREQUENCY RANGE	Below 1000MHz
INPUT POWER (SYSTEM)	120Vac, 60 Hz	DETECTOR FUNCTION	Quasi-Peak
ENVIRONMENTAL CONDITIONS	22deg. C, 70%RH	TEST MODE	A
TESTED BY	Sun Lin		

ANTENNA POLARITY & TEST DISTANCE: HORIZONTAL AT 3 M								
NO.	FREQ. (MHz)	EMISSION LEVEL (dBuV/m)	LIMIT (dBuV/m)	MARGIN (dB)	ANTENNA HEIGHT (m)	TABLE ANGLE (Degree)	RAW VALUE (dBuV)	CORRECTION FACTOR (dB/m)
1	148.34	32.5 QP	43.5	-11.0	1.00 H	102	18.60	13.90
2	220.12	32.3 QP	46.0	-13.7	1.00 H	210	20.30	12.00
3	297.72	29.4 QP	46.0	-16.6	1.00 H	97	14.60	14.80
4	454.86	32.6 QP	46.0	-13.4	1.25 H	7	13.70	18.90
5	499.48	31.1 QP	46.0	-14.9	1.25 H	220	11.00	20.10
6	625.58	32.7 QP	46.0	-13.3	1.25 H	7	10.20	22.50
ANTENNA POLARITY & TEST DISTANCE: VERTICAL AT 3 M								
NO.	FREQ. (MHz)	EMISSION LEVEL (dBuV/m)	LIMIT (dBuV/m)	MARGIN (dB)	ANTENNA HEIGHT (m)	TABLE ANGLE (Degree)	RAW VALUE (dBuV)	CORRECTION FACTOR (dB/m)
1	146.40	33.7 QP	43.5	-9.8	1.00 V	215	19.90	13.80
2	216.24	31.0 QP	46.0	-15.0	1.00 V	313	19.20	11.80
3	297.72	29.0 QP	46.0	-17.0	1.00 V	163	14.20	14.80
4	454.86	28.6 QP	46.0	-17.4	1.00 V	15	9.70	18.90
5	625.58	31.4 QP	46.0	-14.6	1.50 V	34	8.90	22.50
6	875.84	36.0 QP	46.0	-10.0	1.00 V	357	10.00	26.00

**REMARKS:**

1. Emission level (dBuV/m) = Raw Value (dBuV) + Correction Factor (dB/m).
2. Correction Factor (dB/m) = Antenna Factor (dB/m) + Cable Factor (dB).
3. The other emission levels were very low against the limit.
4. Margin value = Emission level – Limit value.





EUT TEST CONDITION		MEASUREMENT DETAIL	
CHANNEL	Channel 149	FREQUENCY RANGE	Below 1000MHz
INPUT POWER (SYSTEM)	120Vac, 60 Hz	DETECTOR FUNCTION	Quasi-Peak
ENVIRONMENTAL CONDITIONS	25deg. C, 68%RH	TEST MODE	B
TESTED BY	Sun Lin		

ANTENNA POLARITY & TEST DISTANCE: HORIZONTAL AT 3 M								
NO.	FREQ. (MHz)	EMISSION LEVEL (dBuV/m)	LIMIT (dBuV/m)	MARGIN (dB)	ANTENNA HEIGHT (m)	TABLE ANGLE (Degree)	RAW VALUE (dBuV)	CORRECTION FACTOR (dB/m)
1	161.92	31.3 QP	43.5	-12.2	1.50 H	295	17.40	13.90
2	280.26	28.1 QP	46.0	-17.9	1.00 H	84	13.90	14.20
3	452.92	31.9 QP	46.0	-14.1	1.50 H	215	13.10	18.80
4	499.48	30.6 QP	46.0	-15.4	1.50 H	211	10.50	20.10
5	625.58	29.0 QP	46.0	-17.0	1.00 H	250	6.50	22.50
6	875.84	32.3 QP	46.0	-13.7	1.25 H	232	6.30	26.00
ANTENNA POLARITY & TEST DISTANCE: VERTICAL AT 3 M								
NO.	FREQ. (MHz)	EMISSION LEVEL (dBuV/m)	LIMIT (dBuV/m)	MARGIN (dB)	ANTENNA HEIGHT (m)	TABLE ANGLE (Degree)	RAW VALUE (dBuV)	CORRECTION FACTOR (dB/m)
1	78.50	32.4 QP	40.0	-7.6	1.00 V	71	22.10	10.30
2	159.98	29.4 QP	43.5	-14.1	1.50 V	192	15.40	14.00
3	189.08	29.5 QP	43.5	-14.0	1.00 V	222	17.50	12.00
4	274.44	29.7 QP	46.0	-16.3	1.25 V	13	15.80	13.90
5	375.32	28.4 QP	46.0	-17.6	1.25 V	211	11.60	16.80
6	452.92	27.5 QP	46.0	-18.5	1.00 V	300	8.70	18.80

**REMARKS:**

1. Emission level (dBuV/m) = Raw Value (dBuV) + Correction Factor (dB/m).
2. Correction Factor (dB/m) = Antenna Factor (dB/m) + Cable Factor (dB).
3. The other emission levels were very low against the limit.
4. Margin value = Emission level – Limit value.

## 5.2 CONDUCTED EMISSION MEASUREMENT

### 5.2.1 LIMITS OF CONDUCTED EMISSION MEASUREMENT

FREQUENCY OF EMISSION (MHz)	CONDUCTED LIMIT (dB $\mu$ V)	
	Quasi-peak	Average
0.15 ~ 0.5	66 to 56	56 to 46
0.5 ~ 5	56	46
5 ~ 30	60	50

- NOTE:**
1. The lower limit shall apply at the transition frequencies.
  2. The limit decreases in line with the logarithm of the frequency in the range of 0.15 to 0.50MHz.
  3. All emanations from a class A/B digital device or system, including any network of conductors and apparatus connected thereto, shall not exceed the level of field strengths specified above.

### 5.2.2 TEST INSTRUMENTS

Same as item 4.2.2.

### 5.2.3 TEST PROCEDURES

Same as item 4.2.3.

### 5.2.4 DEVIATION FROM TEST STANDARD

No deviation.

### 5.2.5 TEST SETUP

Same as item 4.2.5.

### 5.2.6 EUT OPERATING CONDITIONS

Same as 4.1.6

### 5.2.7 TEST RESULTS

#### CONDUCTED WORST-CASE DATA : 802.11a

PHASE	Line 1	6dB BANDWIDTH	9kHz
TEST MODE	A		

No	Freq. [MHz]	Corr. Factor (dB)	Reading Value		Emission Level		Limit		Margin	
			[dB (uV)]		[dB (uV)]		[dB (uV)]		(dB)	
			Q.P.	AV.	Q.P.	AV.	Q.P.	AV.	Q.P.	AV.
1	0.18516	0.13	46.62	35.82	46.75	35.95	64.25	54.25	-17.51	-18.31
2	0.36094	0.13	41.35	38.15	41.48	38.28	58.71	48.71	-17.23	-10.43
3	0.88438	0.18	33.89	24.49	34.07	24.67	56.00	46.00	-21.93	-21.33
4	1.50391	0.21	35.44	30.30	35.65	30.51	56.00	46.00	-20.35	-15.49
5	2.25781	0.24	33.41	27.80	33.65	28.04	56.00	46.00	-22.35	-17.96
6	21.56250	1.24	22.32	15.74	23.56	16.98	60.00	50.00	-36.44	-33.02

#### REMARKS:

1. Q.P. and AV. are abbreviations of quasi-peak and average individually.
2. The emission levels of other frequencies were very low against the limit.
3. Margin value = Emission level - Limit value
4. Correction factor = Insertion loss + Cable loss
5. Emission Level = Correction Factor + Reading Value.

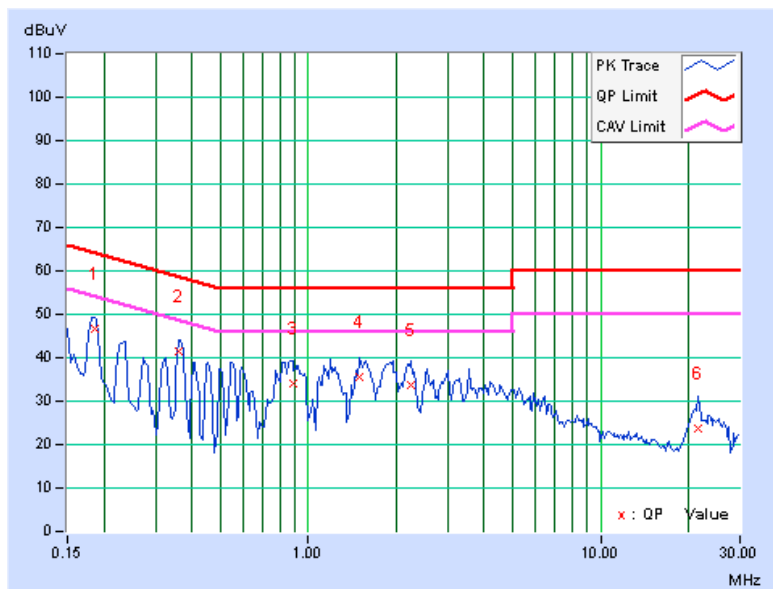



A D T

PHASE	Line 2	6dB BANDWIDTH	9kHz
TEST MODE	A		

No	Freq. [MHz]	Corr. Factor (dB)	Reading Value		Emission Level		Limit		Margin	
			[dB (uV)]		[dB (uV)]		[dB (uV)]		(dB)	
			Q.P.	AV.	Q.P.	AV.	Q.P.	AV.	Q.P.	AV.
1	0.18125	0.13	47.99	37.75	48.12	37.88	64.43	54.43	-16.30	-16.54
2	0.36875	0.15	40.01	37.12	40.16	37.27	58.53	48.53	-18.37	-11.26
3	0.81406	0.19	36.19	29.96	36.38	30.15	56.00	46.00	-19.62	-15.85
4	1.56250	0.22	34.70	29.41	34.92	29.63	56.00	46.00	-21.08	-16.37
5	3.21094	0.30	31.27	26.19	31.57	26.49	56.00	46.00	-24.43	-19.51
6	7.88281	0.51	23.97	19.27	24.48	19.78	60.00	50.00	-35.52	-30.22

**REMARKS:**

1. Q.P. and AV. are abbreviations of quasi-peak and average individually.
2. The emission levels of other frequencies were very low against the limit.
3. Margin value = Emission level - Limit value
4. Correction factor = Insertion loss + Cable loss
5. Emission Level = Correction Factor + Reading Value.

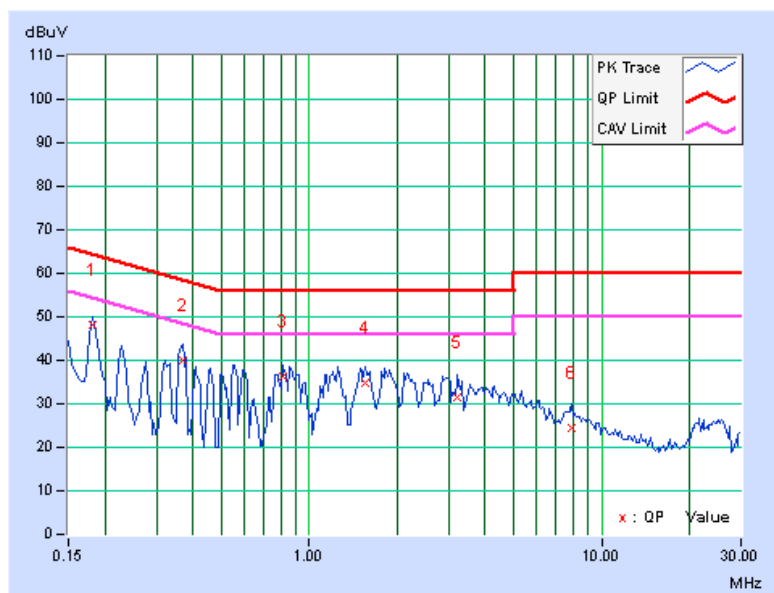

PHASE	Line 1	6dB BANDWIDTH	9kHz
TEST MODE	B		

No	Freq. [MHz]	Corr. Factor (dB)	Reading Value		Emission Level		Limit		Margin	
			[dB (uV)]		[dB (uV)]		[dB (uV)]		(dB)	
			Q.P.	AV.	Q.P.	AV.	Q.P.	AV.	Q.P.	AV.
1	0.16172	0.12	41.98	32.49	42.10	32.61	65.38	55.38	-23.28	-22.77
2	0.20078	0.13	36.67	26.69	36.80	26.82	63.58	53.58	-26.78	-26.76
3	0.49375	0.14	34.38	33.89	34.52	34.03	56.10	46.10	-21.59	-12.08
4	1.37891	0.20	23.37	20.73	23.57	20.93	56.00	46.00	-32.43	-25.07
5	3.62891	0.32	25.93	18.79	26.25	19.11	56.00	46.00	-29.75	-26.89
6	22.91406	1.31	36.11	30.40	37.42	31.71	60.00	50.00	-22.58	-18.29

**REMARKS:**

1. Q.P. and AV. are abbreviations of quasi-peak and average individually.
2. The emission levels of other frequencies were very low against the limit.
3. Margin value = Emission level - Limit value
4. Correction factor = Insertion loss + Cable loss
5. Emission Level = Correction Factor + Reading Value.

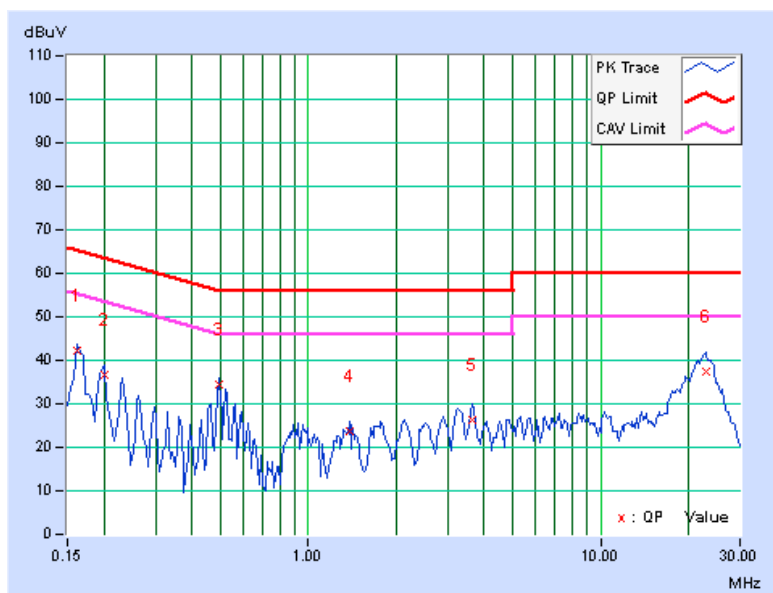

PHASE	Line 2	6dB BANDWIDTH	9kHz
TEST MODE	B		

No	Freq. [MHz]	Corr. Factor (dB)	Reading Value		Emission Level		Limit		Margin	
			[dB (uV)]		[dB (uV)]		[dB (uV)]		(dB)	
			Q.P.	AV.	Q.P.	AV.	Q.P.	AV.	Q.P.	AV.
1	0.16562	0.13	42.45	33.27	42.58	33.40	65.18	55.18	-22.60	-21.78
2	0.20078	0.14	36.51	26.77	36.65	26.91	63.58	53.58	-26.93	-26.67
3	0.49375	0.16	34.47	33.97	34.63	34.13	56.10	46.10	-21.48	-11.98
4	1.38281	0.22	23.52	20.77	23.74	20.99	56.00	46.00	-32.26	-25.01
5	3.65625	0.33	26.15	19.56	26.48	19.89	56.00	46.00	-29.52	-26.11
6	22.63281	1.06	36.21	30.40	37.27	31.46	60.00	50.00	-22.73	-18.54

**REMARKS:**

1. Q.P. and AV. are abbreviations of quasi-peak and average individually.
2. The emission levels of other frequencies were very low against the limit.
3. Margin value = Emission level - Limit value
4. Correction factor = Insertion loss + Cable loss
5. Emission Level = Correction Factor + Reading Value.

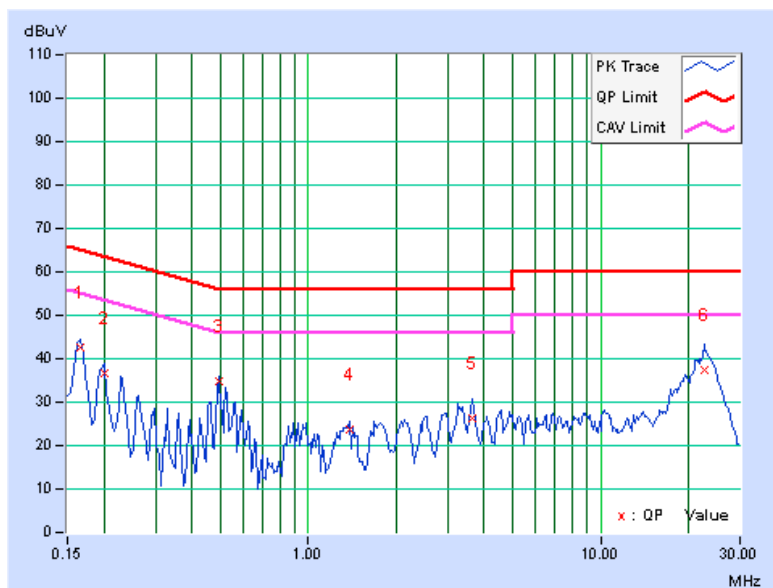

### **5.3 6dB BANDWIDTH MEASUREMENT**

#### **5.3.1 LIMITS OF 6dB BANDWIDTH MEASUREMENT**

The minimum of 6dB Bandwidth Measurement is 0.5MHz.

#### **5.3.2 TEST SETUP**

Same as item 4.3.2.

#### **5.3.3 TEST INSTRUMENTS**

Refer to section 4.1.2 to get information of above instrument.

#### **5.3.4 TEST PROCEDURE**

Same as item 4.3.4.

#### **5.3.5 DEVIATION FROM TEST STANDARD**

No deviation.

#### **5.3.6 EUT OPERATING CONDITIONS**

Same as item 4.3.6.

### 5.3.7 TEST RESULTS

#### 802.11a

CHANNEL	FREQUENCY (MHz)	6dB BANDWIDTH (MHz)		MINIMUM LIMIT (MHz)	PASS / FAIL
		CHAIN 0	CHAIN 1		
149	5745	16.51	16.56	0.5	PASS
157	5785	16.63	16.58	0.5	PASS
165	5825	16.52	16.57	0.5	PASS

#### 802.11n (20MHz)

CHANNEL	FREQUENCY (MHz)	6dB BANDWIDTH (MHz)		MINIMUM LIMIT (MHz)	PASS / FAIL
		CHAIN 0	CHAIN 1		
149	5745	17.71	17.72	0.5	PASS
157	5785	17.73	17.75	0.5	PASS
165	5825	17.75	17.71	0.5	PASS

#### 802.11n (40MHz)

CHANNEL	FREQUENCY (MHz)	6dB BANDWIDTH (MHz)		MINIMUM LIMIT (MHz)	PASS / FAIL
		CHAIN 0	CHAIN 1		
151	5755	36.29	36.35	0.5	PASS
159	5795	36.45	36.56	0.5	PASS



## **5.4 CONDUCTED OUTPUT POWER**

### **5.4.1 LIMITS OF CONDUCTED OUTPUT POWER MEASUREMENT**

For systems using digital modulation in the 5725 –5850 MHz bands: 1 Watt (30dBm)

### **5.4.2 TEST SETUP**

Same as Item 4.4.2.

### **5.4.3 INSTRUMENTS**

Refer to section 4.1.2 to get information of above instrument.

### **5.4.4 TEST PROCEDURES**

Same as Item 4.4.4.

### **5.4.5 DEVIATION FROM TEST STANDARD**

No deviation.

### **5.4.6 EUT OPERATING CONDITIONS**

Same as Item 4.3.6.

## 5.4.7 TEST RESULTS

### 802.11a

CHAN.	FREQUENCY (MHz)	PEAK POWER (dBm)		TOTAL POWER (mW)	TOTAL POWER (dBm)	LIMIT (dBm)	PASS / FAIL
		CHAIN 0	CHAIN 1				
149	5745	22.01	21.91	314.1	24.97	28	PASS
157	5785	21.99	21.45	297.8	24.74	28	PASS
165	5825	21.94	21.35	292.8	24.67	28	PASS

**NOTE:** Directional gain =  $5\text{dBi} + 10\log(2) = 8\text{dBi} > 6\text{dBi}$ , so the limit shall be reduced to  $30 - (8 - 6) = 28\text{dBm}$ .

### 802.11n (20MHz)

CHAN.	FREQUENCY (MHz)	PEAK POWER (dBm)		TOTAL POWER (mW)	TOTAL POWER (dBm)	LIMIT (dBm)	PASS / FAIL
		CHAIN 0	CHAIN 1				
149	5745	21.45	21.32	275.2	24.40	28	PASS
157	5785	21.47	21.58	284.2	24.54	28	PASS
165	5825	21.41	21.42	277.0	24.43	28	PASS

**NOTE:** Directional gain =  $5\text{dBi} + 10\log(2) = 8\text{dBi} > 6\text{dBi}$ , so the limit shall be reduced to  $30 - (8 - 6) = 28\text{dBm}$ .

### 802.11n (40MHz)

CHAN.	FREQUENCY (MHz)	PEAK POWER (dBm)		TOTAL POWER (mW)	TOTAL POWER (dBm)	LIMIT (dBm)	PASS / FAIL
		CHAIN 0	CHAIN 1				
151	5755	21.84	21.99	310.9	24.93	28	PASS
159	5795	21.81	21.78	302.4	24.81	28	PASS

**NOTE:** Directional gain =  $5\text{dBi} + 10\log(2) = 8\text{dBi} > 6\text{dBi}$ , so the limit shall be reduced to  $30 - (8 - 6) = 28\text{dBm}$ .

## **5.5 POWER SPECTRAL DENSITY MEASUREMENT**

### **5.5.1 LIMITS OF POWER SPECTRAL DENSITY MEASUREMENT**

The Maximum of Power Spectral Density Measurement is 8dBm.

### **5.5.2 TEST SETUP**

Same as item 4.5.2.

### **5.5.3 TEST INSTRUMENTS**

Refer to section 4.1.2 to get information of above instrument.

### **5.5.4 TEST PROCEDURE.**

Same as item 4.5.4.

### **5.5.5 DEVIATION FROM TEST STANDARD**

No deviation.

### **5.5.6 EUT OPERATING CONDITION**

Same as item 4.3.6.

## 5.5.7 TEST RESULTS

### 802.11a

TX chain	Channel	FREQ. (MHz)	PSD (dBm/100kHz)	PSD (dBm/3kHz)	10 log (N=2) dB	Total PSD (dBm/3kHz)	Limit (dBm/3kHz)	PASS /FAIL
0	149	5745	2.66	-12.57	3.01	-9.56	6	PASS
	157	5785	2.71	-12.52	3.01	-9.51	6	PASS
	165	5825	2.76	-12.47	3.01	-9.46	6	PASS
1	149	5745	3.48	-11.75	3.01	-8.74	6	PASS
	157	5785	3.06	-12.17	3.01	-9.16	6	PASS
	165	5825	2.95	-12.28	3.01	-9.27	6	PASS

**NOTE:** Directional gain = 5dBi + 10log(2) = 8dBi > 6dBi , so the limit shall be reduced to 8-(8-6) = 6dBm.

### 802.11n (20MHz)

TX chain	Channel	FREQ. (MHz)	PSD (dBm/100kHz)	PSD (dBm/3kHz)	10 log (N=2) dB	Total PSD (dBm/3kHz)	Limit (dBm/3kHz)	PASS /FAIL
0	149	5745	2.79	-12.44	3.01	-9.43	6	PASS
	157	5785	2.73	-12.5	3.01	-9.49	6	PASS
	165	5825	2.88	-12.35	3.01	-9.34	6	PASS
1	149	5745	3.01	-12.22	3.01	-9.21	6	PASS
	157	5785	3.18	-12.05	3.01	-9.04	6	PASS
	165	5825	3.08	-12.15	3.01	-9.14	6	PASS

**NOTE:** Directional gain = 5dBi + 10log(2) = 8dBi > 6dBi , so the limit shall be reduced to 8-(8-6) = 6dBm.

### 802.11n (40MHz)

TX chain	Channel	FREQ. (MHz)	PSD (dBm/100kHz)	PSD (dBm/3kHz)	10 log (N=2) dB	Total PSD (dBm/3kHz)	Limit (dBm/3kHz)	PASS /FAIL
0	151	5755	0.25	-14.98	3.01	-11.97	6	PASS
	159	5795	0.03	-15.20	3.01	-12.19	6	PASS
1	151	5755	1.87	-13.36	3.01	-10.35	6	PASS
	159	5795	1.62	-13.61	3.01	-10.60	6	PASS

**NOTE:** Directional gain = 5dBi + 10log(2) = 8dBi > 6dBi , so the limit shall be reduced to 8-(8-6) = 6dBm.

## **5.6 CONDUCTED OUT OF BAND EMISSION MEASUREMENT**

### **5.6.1 LIMITS OF CONDUCTED OUT OF BAND EMISSION MEASUREMENT**

Below  $-20\text{dB}$  of the highest emission level of operating band (in 100kHz Resolution Bandwidth).

### **5.6.2 TEST SETUP**

Same as Item 4.6.2

### **5.6.3 TEST INSTRUMENTS**

Refer to section 4.1.2 to get information of above instrument.

### **5.6.4 TEST PROCEDURE**

Same as Item 4.6.4

### **5.6.5 DEVIATION FROM TEST STANDARD**

No deviation.

### **5.6.6 EUT OPERATING CONDITION**

Same as Item 4.3.6

### **5.6.7 TEST RESULTS**

The conducted emission test is performed on each TX port of operating mode without summing or adding  $10\log(N)$  since the limit is relative emission limit. Only worst data of each operating mode is presented.

The spectrum plots are attached on the following pages. D1 line indicates the highest level, and D2 line indicates the 20dB offset below D1. It shows compliance with the requirement.



A D T

### 802.11a

#### CH 149

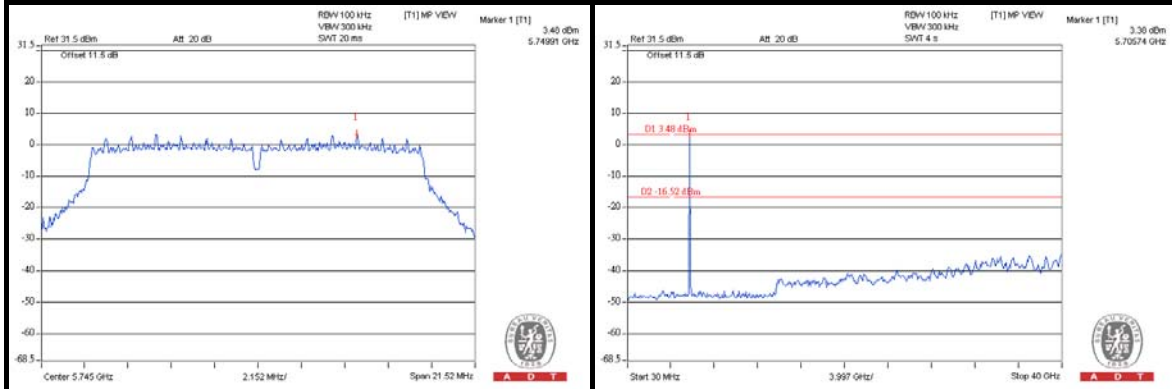

#### CH 157

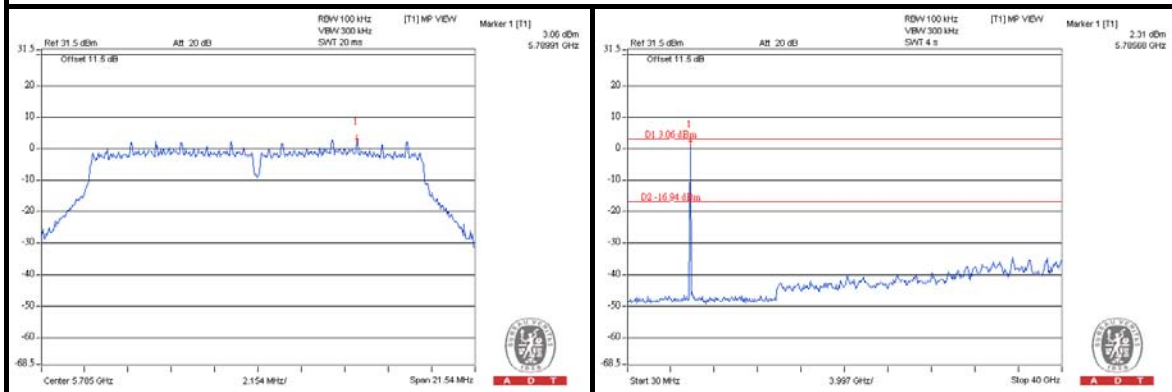

#### CH 165

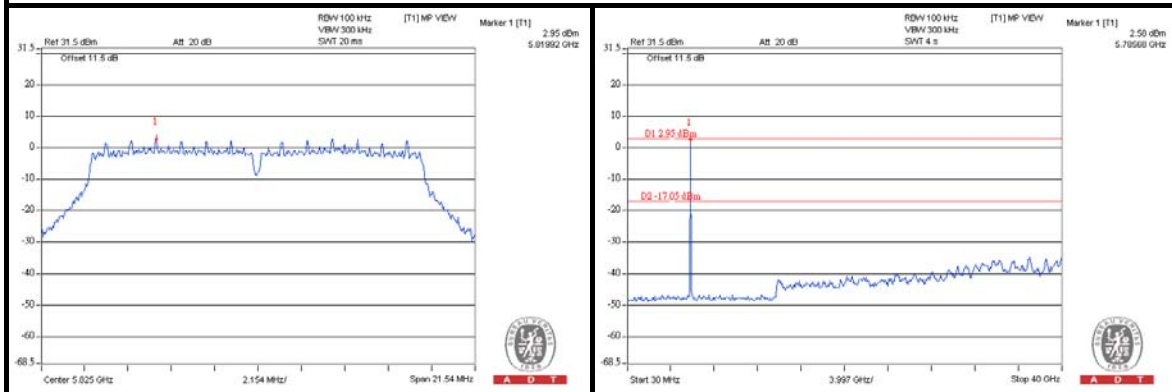



### 802.11n (20MHz)

#### CH 149

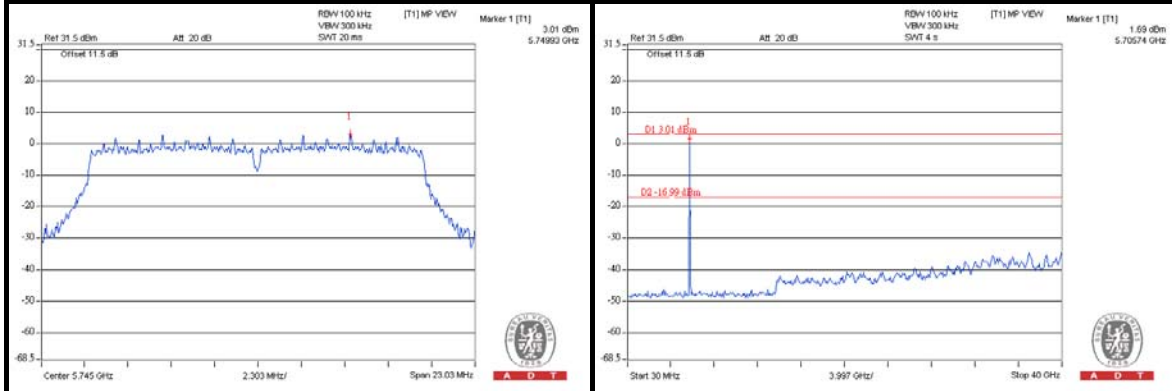

#### CH 157

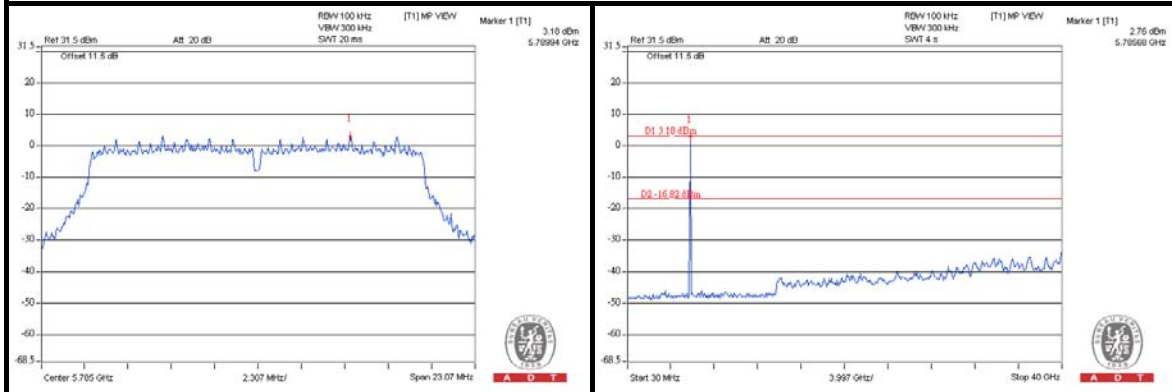

#### CH 165

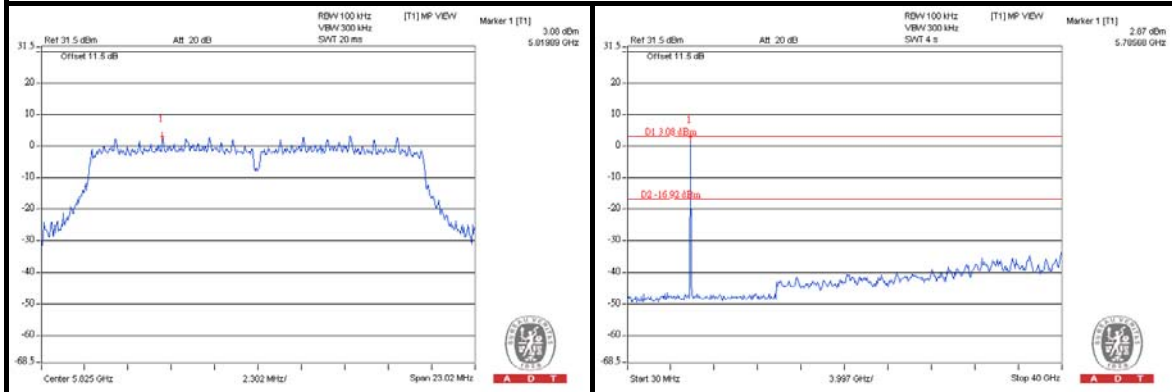



A D T

## 802.11n (40MHz)

### CH 151

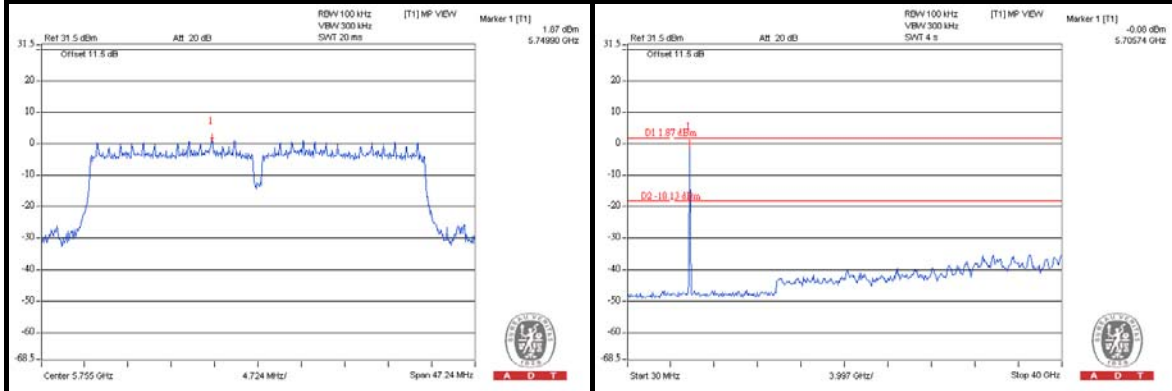

### CH 159

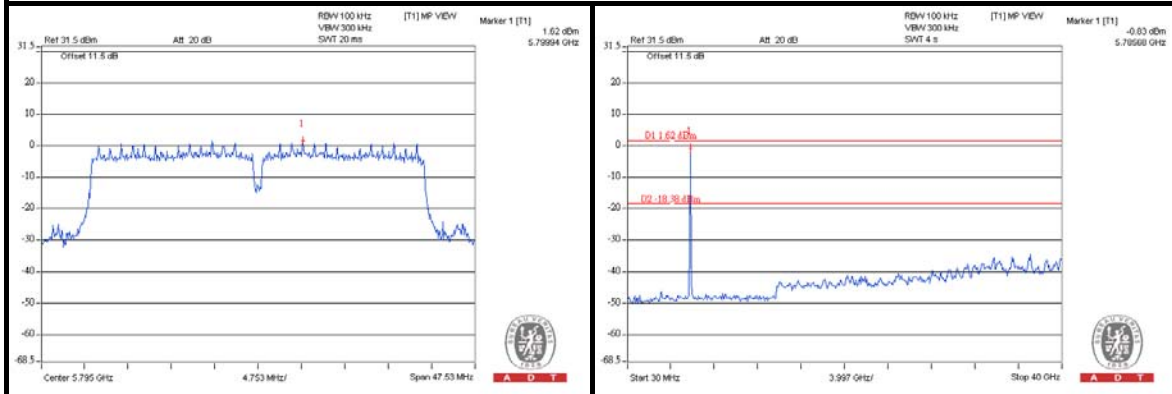



## 6. PHOTOGRAPHS OF THE TEST CONFIGURATION

Please refer to the attached file (Test Setup Photo).



## 7. INFORMATION ON THE TESTING LABORATORIES

We, Bureau Veritas Consumer Products Services (H.K.) Ltd., Taoyuan Branch, were founded in 1988 to provide our best service in EMC, Radio, Telecom and Safety consultation. Our laboratories are accredited and approved according to ISO/IEC 17025.

If you have any comments, please feel free to contact us at the following:

**Linko EMC/RF Lab**

Tel: 886-2-26052180

Fax: 886-2-26051924

**Hsin Chu EMC/RF Lab**

Tel: 886-3-5935343

Fax: 886-3-5935342

**Hwa Ya EMC/RF/Safety/Telecom Lab**

Tel: 886-3-3183232

Fax: 886-3-3270892

**Email:** [service.adt@tw.bureauveritas.com](mailto:service.adt@tw.bureauveritas.com)

**Web Site:** [www.adt.com.tw](http://www.adt.com.tw)

The address and road map of all our labs can be found in our web site also.

## **8. APPENDIX A - MODIFICATIONS RECORDERS FOR ENGINEERING CHANGES TO THE EUT BY THE LAB**

No modifications were made to the EUT by the lab during the test.

**---END---**