



# FCC TEST REPORT (15.407)

**REPORT NO.:** RF960711L07-1  
**MODEL NO.:** RSVLC-0702  
**RECEIVED:** Jul. 27, 2007  
**TESTED:** Jul. 27 ~ Aug. 01, 2007  
**ISSUED:** Aug. 06, 2007

**APPLICANT:** Hewlett-Packard Company

**ADDRESS:** 3000 Hanover Street, Palo Alto, CA 94304, USA

**ISSUED BY:** Advance Data Technology Corporation

**LAB ADDRESS:** No. 47, 14<sup>th</sup> Ling, Chia Pau Tsuen, Lin Kou Hsiang 244, Taipei Hsien, Taiwan, R.O.C.

**TEST LOCATION:** No. 19, Hwa Ya 2<sup>nd</sup> Rd., Wen Hwa Tsuen, Kwei Shan Hsiang, Taoyuan Hsien 333, Taiwan, R.O.C.

This test report consists of 53 pages in total. It may be duplicated completely for legal use with the approval of the applicant. It should not be reproduced except in full, without the written approval of our laboratory. The client should not use it to claim product endorsement by TAF, A2LA or any government agencies. The test results in the report only apply to the tested sample.





## Table of contents

1.	CERTIFICATION .....	4
2.	SUMMARY OF TEST RESULTS .....	5
2.1	MEASUREMENT UNCERTAINTY .....	5
3.	GENERAL INFORMATION.....	6
3.1	GENERAL DESCRIPTION OF EUT .....	6
3.2	DESCRIPTION OF TEST MODES.....	7
3.2.1	CONFIGURATION OF SYSTEM UNDER TEST .....	8
3.2.2	TEST MODE APPLICABILITY AND TESTED CHANNEL DETAIL:.....	9
3.3	GENERAL DESCRIPTION OF APPLIED STANDARDS .....	11
3.4	DESCRIPTION OF SUPPORT UNITS .....	11
4.	TEST TYPES AND RESULTS .....	12
4.1	CONDUCTED EMISSION MEASUREMENT .....	12
4.1.1	LIMITS OF CONDUCTED EMISSION MEASUREMENT.....	12
4.1.2	TEST INSTRUMENTS .....	12
4.1.3	TEST PROCEDURES .....	13
4.1.4	DEVIATION FROM TEST STANDARD .....	13
4.1.5	TEST SETUP .....	14
4.1.6	EUT OPERATING CONDITIONS .....	14
4.1.7	TEST RESULTS .....	15
4.2	RADIATED EMISSION MEASUREMENT .....	19
4.2.1	LIMITS OF RADIATED EMISSION MEASUREMENT.....	19
4.2.2	LIMITS OF UNWANTED EMISSION OUT OF THE RESTRICTED BANDS.....	19
4.2.3	TEST INSTRUMENTS .....	20
4.2.4	TEST PROCEDURES .....	21
4.2.5	DEVIATION FROM TEST STANDARD .....	21
4.2.6	TEST SETUP .....	22
4.2.7	EUT OPERATING CONDITION .....	22
4.2.8	TEST RESULTS .....	23
4.3	PEAK TRANSMIT POWER MEASUREMENT .....	28
4.3.1	LIMITS OF PEAK TRANSMIT POWER MEASUREMENT .....	28
4.3.2	TEST INSTRUMENTS .....	28
4.3.3	TEST PROCEDURE .....	29
4.3.4	DEVIATION FROM TEST STANDARD .....	29
4.3.5	TEST SETUP .....	29
4.3.6	EUT OPERATING CONDITIONS .....	29
4.3.7	TEST RESULTS .....	30
4.4	PEAK POWER EXCURSION MEASUREMENT .....	34
4.4.1	LIMITS OF PEAK POWER EXCURSION MEASUREMENT.....	34
4.4.2	TEST INSTRUMENTS .....	34
4.4.3	TEST PROCEDURE .....	35
4.4.4	DEVIATION FROM TEST STANDARD .....	35
4.4.5	TEST SETUP .....	35
4.4.6	EUT OPERATING CONDITIONS .....	35
4.4.7	TEST RESULTS .....	36
4.5	PEAK POWER SPECTRAL DENSITY MEASUREMENT .....	38
4.5.1	LIMITS OF PEAK POWER SPECTRAL DENSITY MEASUREMENT.....	38



4.5.2	TEST INSTRUMENTS .....	38
4.5.3	TEST PROCEDURES .....	39
4.5.4	DEVIATION FROM TEST STANDARD .....	39
4.5.5	TEST SETUP .....	39
4.5.6	EUT OPERATING CONDITIONS .....	39
4.5.7	TEST RESULTS .....	40
4.6	FREQUENCY STABILITY .....	42
4.6.1	LIMITS OF FREQUENCY STABILITY MEASUREMENT .....	42
4.6.2	TEST INSTRUMENTS .....	42
4.6.3	TEST PROCEDURE .....	42
4.6.4	DEVIATION FROM TEST STANDARD .....	43
4.6.5	TEST SETUP .....	43
4.6.6	EUT OPERATING CONDITION .....	43
4.6.7	TEST RESULTS .....	44
4.7	BAND EDGES MEASUREMENT .....	45
4.7.1	TEST INSTRUMENTS .....	45
4.7.2	TEST PROCEDURE .....	45
4.7.3	EUT OPERATING CONDITION .....	45
4.7.4	TEST RESULTS .....	45
4.8	ANTENNA REQUIREMENT .....	50
4.8.1	STANDARD APPLICABLE .....	50
4.8.2	ANTENNA CONNECTED CONSTRUCTION .....	50
5.	PHOTOGRAPHS OF THE TEST CONFIGURATION.....	51
6.	INFORMATION ON THE TESTING LABORATORIES .....	52
7.	APPENDIX A - MODIFICATIONS RECORDERS FOR ENGINEERING CHANGES TO THE EUT BY THE LAB .....	53



## 1. CERTIFICATION

**PRODUCT:** ProCurve Wireless Access Point 10AG

**MODEL:** RSVLC-0702

**BRAND:** hp

**APPLICANT:** Hewlett-Packard Company

**TEST SAMPLE:** ENGINEERING SAMPLE

**TESTED:** Jul. 27 ~ Aug. 01, 2007

**STANDARDS: FCC Part 15, Subpart E (Section 15.407)**  
ANSI C63.4-2003

The above equipment (Model: RSVLC-0702) has been tested by **Advance Data Technology Corporation**, and found compliance with the requirement of the above standards. The test record, data evaluation & Equipment Under Test (EUT) configurations represented herein are true and accurate accounts of the measurements of the sample's EMC characteristics under the conditions specified in this report.

**PREPARED BY** : Andrea Hsia , **DATE:** Aug. 06, 2007  
Andrea Hsia / Specialist

**TECHNICAL ACCEPTANCE** : Long Chen , **DATE:** Aug. 06, 2007  
Responsible for RF Long Chen / Senior Engineer

**APPROVED BY** : Gary Chang , **DATE:** Aug. 06, 2007  
Gary Chang / Assistant Manager

## 2. SUMMARY OF TEST RESULTS

The EUT has been tested according to the following specifications:

APPLIED STANDARD: FCC Part 15, Subpart E (Section 15.407)			
Standard Section	Test Type	Result	Remark
15.407(b)(5)	AC Power Conducted Emission	PASS	Meet the requirement of limit. Minimum passing margin is -11.33dB at 0.201MHz
15.407(b/1/2/3)(b)(5)	Electric Field Strength Spurious Emissions, 30MHz ~ 40000MHz	PASS	Meet the requirement of limit. Minimum passing margin is -2.16dB at 10400.00MHz
15.407(a/1/2/3)	Peak Transmit Power	PASS	Meet the requirement of limit.
15.407(a)(6)	Peak Power Excursion	PASS	Meet the requirement of limit.
15.407(a/1/2/3)	Peak Power Spectral Density	PASS	Meet the requirement of limit.
15.407(g)	Frequency Stability	PASS	Meet the requirement of limit.

### 2.1 MEASUREMENT UNCERTAINTY

Where relevant, the following measurement uncertainty levels have been estimated for tests performed on the EUT as specified in CISPR 16-4:

Measurement	Frequency	Uncertainty
Conducted emissions	9kHz~30MHz	2.44 dB
Radiated emissions	30MHz ~ 200MHz	3.19 dB
	200MHz ~1000MHz	3.21 dB
	1GHz ~ 18GHz	2.26 dB
	18GHz ~ 40GHz	1.94 dB

This uncertainty represents an expanded uncertainty expressed at approximately the 95% confidence level using a coverage factor of k=2.



### 3. GENERAL INFORMATION

#### 3.1 GENERAL DESCRIPTION OF EUT

<b>EUT</b>	ProCurve Wireless Access Point 10AG
<b>MODEL NO.</b>	RSVLC-0702
<b>FCC ID</b>	B94RSVLC-0702
<b>POWER SUPPLY</b>	12Vdc from AC Adapter 48Vdc from POE
<b>MODULATION TYPE</b>	CCK, DQPSK, DBPSK for DSSS 64QAM, 16QAM, QPSK, BPSK for OFDM
<b>MODULATION TECHNOLOGY</b>	DSSS, OFDM
<b>TRANSFER RATE</b>	802.11b: 11/5.5/2/1Mbps 802.11g: 54/48/36/24/18/12/9/6Mbps 802.11a: 54/48/36/24/18/12/9/6Mbps
<b>FREQUENCY RANGE</b>	802.11b & 802.11g: 2.412 ~ 2.462GHz 802.11a: 5.180 ~ 5.240GHz; 5.745 ~ 5.825GHz
<b>NUMBER OF CHANNEL</b>	802.11b & 802.11g: 11 802.11a: 9
<b>CHANNEL SPACING</b>	802.11b & 802.11g: 5MHz 802.11a: 20MHz
<b>OUTPUT POWER</b>	65.163mW for 802.11b 58.479mW for 802.11g 40.365mW for 5.180 ~ 5.240GHz 66.527mW for 5.745 ~ 5.825GHz
<b>ANTENNA TYPE</b>	Dipole antenna with 1.78dBi gain for 2.4GHz Dipole antenna with 1.65dBi gain for 5.180 ~ 5.240GHz Dipole antenna with 1.78dBi gain for 5.725 ~ 5.825GHz
<b>DATA CABLE</b>	NA
<b>I/O PORTS</b>	RJ45
<b>ACCESSORY DEVICES</b>	Adapter

**NOTE:**

1. The EUT was operated with following adapter and POE.

ADAPTER	
<b>BRAND:</b>	DELTA ELECTRONIC INC.
<b>MODEL:</b>	EADP-15DB A
<b>INPUT:</b>	100-240Vac, 50-60Hz, 0.5A
<b>OUTPUT:</b>	12Vdc, 1.25A,
<b>POWER LINE:</b>	DC 1.8m non-shielded cable without core AC 1.8m non-shielded cable without core

POE	
<b>MODEL:</b>	0341-0211-01-R
<b>BRAND:</b>	CISCO
<b>OUTPUT:</b>	48Vdc

\*Note: The POE is for support unit only.



2. The EUT operates in both the 5GHz and 2.4GHz Bands and compatibility with 802.11a and 802.11b, 802.11g technology.
3. The above EUT information was declared by the manufacturer and for more detailed features description, please refer to the manufacturer's specifications or User's Manual.

### 3.2 DESCRIPTION OF TEST MODES

Operated in 5180 ~ 5240MHz

4 channels are provided to this EUT.

CHANNEL	FREQUENCY
1	5180 MHz
2	5200 MHz
3	5220 MHz
4	5240 MHz

### 3.2.1 CONFIGURATION OF SYSTEM UNDER TEST

#### TEST MODE A

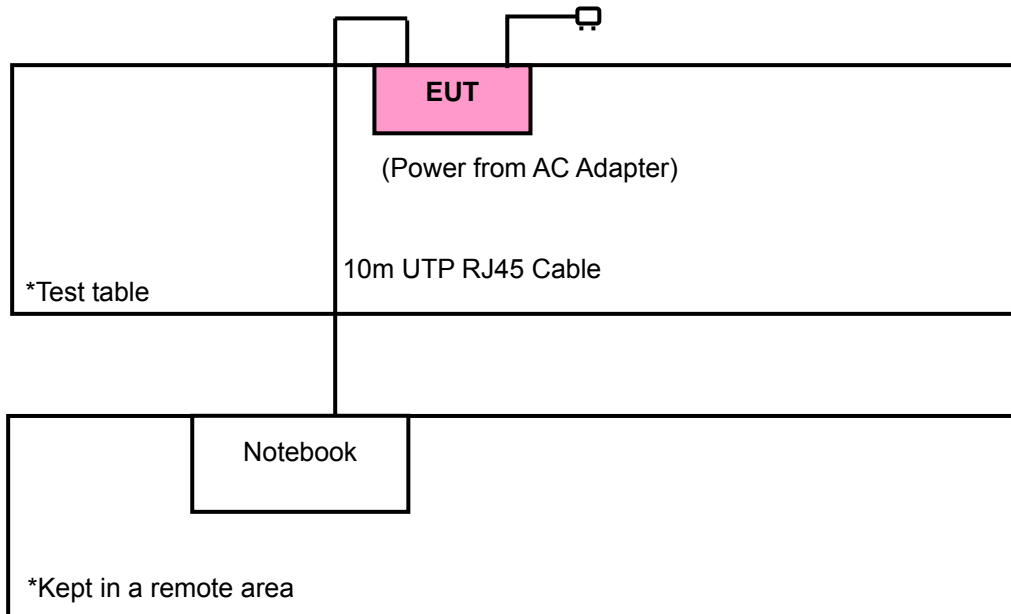

#### TEST MODE B

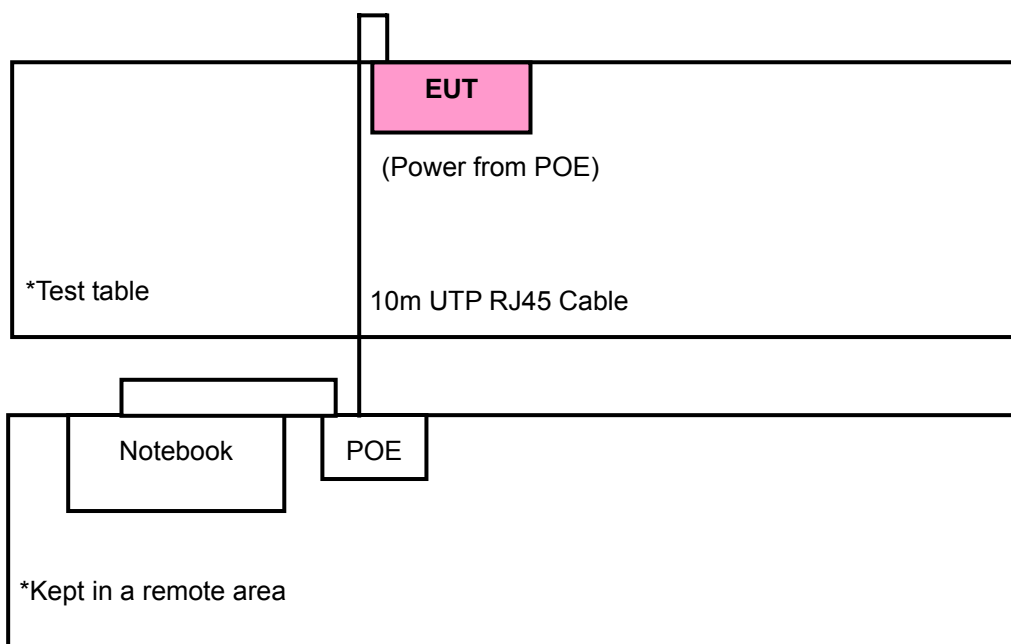



### 3.2.2 TEST MODE APPLICABILITY AND TESTED CHANNEL DETAIL:

EUT CONFIGURE MODE	APPLICABLE TO				DESCRIPTION
	PLC	RE<1G	RE≥1G	APCM	
A	√	√	√	√	Power from AC Adapter
B	√	√	-	-	Power from POE

Where **PLC**: Power Line Conducted Emission

**RE<1G**: Radiated Emission below 1GHz

**RE≥1G**: Radiated Emission above 1GHz

**APCM**: Antenna Port Conducted Measurement

**NOTE**: "-" means no effect

#### Power Line Conducted Emission Test:

- Pre-Scan has been conducted to determine the worst-case mode from all possible combinations between available modulations, data rates and antenna ports (if EUT with antenna diversity architecture).
- Following channel(s) was (were) selected for the final test as listed below.

EUT CONFIGURE MODE	MODE	AVAILABLE CHANNEL	TESTED CHANNEL	MODULATION TECHNOLOGY	MODULATION TYPE	DATA RATE (Mbps)
A	802.11a	1 to 4	4	OFDM	BPSK	6
B	802.11a	1 to 4	4	OFDM	BPSK	6

#### Radiated Emission Test (Below 1 GHz):

- Pre-Scan has been conducted to determine the worst-case mode from all possible combinations between available modulations, data rates, antenna ports (if EUT with antenna diversity architecture).
- Following channel(s) was (were) selected for the final test as listed below.

EUT CONFIGURE MODE	MODE	AVAILABLE CHANNEL	TESTED CHANNEL	MODULATION TECHNOLOGY	MODULATION TYPE	DATA RATE (Mbps)
A	802.11a	1 to 4	4	OFDM	BPSK	6
B	802.11a	1 to 4	4	OFDM	BPSK	6

#### Radiated Emission Test (Above 1 GHz):

- Pre-Scan has been conducted to determine the worst-case mode from all possible combinations between available modulations, data rates and antenna ports (if EUT with antenna diversity architecture).
- Following channel(s) was (were) selected for the final test as listed below.

EUT CONFIGURE MODE	MODE	AVAILABLE CHANNEL	TESTED CHANNEL	MODULATION TECHNOLOGY	MODULATION TYPE	DATA RATE (Mbps)
A	802.11a	1 to 4	1, 2, 4	OFDM	BPSK	6



**Bandedge Measurement:**

- Pre-Scan has been conducted to determine the worst-case mode from all possible combinations between available modulations, data rates and antenna ports (if EUT with antenna diversity architecture).
- Following channel(s) was (were) selected for the final test as listed below.

EUT CONFIGURE MODE	MODE	AVAILABLE CHANNEL	TESTED CHANNEL	MODULATION TECHNOLOGY	MODULATION TYPE	DATA RATE (Mbps)
A	802.11a	1 to 4	1, 4	OFDM	BPSK	6

**Antenna Port Conducted Measurement:**

- Pre-Scan has been conducted to determine the worst-case mode from all possible combinations between available modulations, data rates and antenna ports (if EUT with antenna diversity architecture).
- Following channel(s) was (were) selected for the final test as listed below.

EUT CONFIGURE MODE	MODE	AVAILABLE CHANNEL	TESTED CHANNEL	MODULATION TECHNOLOGY	MODULATION TYPE	DATA RATE (Mbps)
A	802.11a	1 to 4	1, 2, 4	OFDM	BPSK	6



### 3.3 GENERAL DESCRIPTION OF APPLIED STANDARDS

The EUT is a RF Product. According to the specifications of the manufacturer, it must comply with the requirements of the following standards:

#### FCC Part 15, Subpart E (15.407)

#### ANSI C63.4-2003

All test items have been performed and recorded as per the above standards.

**NOTE:** The EUT is also considered as a kind of computer peripheral, because the connection to computer is necessary for typical use. It has been verified to comply with the requirements of FCC Part 15, Subpart B, Class B (DoC). The test report has been issued separately.

### 3.4 DESCRIPTION OF SUPPORT UNITS

The EUT has been tested as an independent unit together with other necessary accessories or support units. The following support units or accessories were used to form a representative test configuration during the tests.

NO.	PRODUCT	BRAND	MODEL NO.	SERIAL NO.	FCC ID
1	NOTEBOOK COMPUTER	DELL	PP05L	9954115984	E2K24CLNS

NO.	SIGNAL CABLE DESCRIPTION OF THE ABOVE SUPPORT UNITS
1	1.5m RJ45 non-shielded cable

**NOTE 1:** All power cords of the above support units are non shielded (1.8m).

**NOTE 2:** Item 2 acted as communication partners to transfer data.



## 4. TEST TYPES AND RESULTS

### 4.1 CONDUCTED EMISSION MEASUREMENT

#### 4.1.1 LIMITS OF CONDUCTED EMISSION MEASUREMENT

FREQUENCY OF EMISSION (MHz)	CONDUCTED LIMIT (dB $\mu$ V)	
	Quasi-peak	Average
0.15-0.5	66 to 56	56 to 46
0.5-5	56	46
5-30	60	50

- NOTE:**
1. The lower limit shall apply at the transition frequencies.
  2. The limit decreases in line with the logarithm of the frequency in the range of 0.15 to 0.50 MHz.
  3. All emanations from a class A/B digital device or system, including any network of conductors and apparatus connected thereto, shall not exceed the level of field strengths specified above.

#### 4.1.2 TEST INSTRUMENTS

DESCRIPTION & MANUFACTURER	MODEL NO.	SERIAL NO.	CALIBRATED UNTIL
Test Receiver ROHDE & SCHWARZ	ESCS30	100289	Dec. 07, 2007
RF signal cable Woken	5D-FB	Cable-HYC01-01	Jan. 06, 2008
LISN ROHDE & SCHWARZ	ESH3-Z5	100312	Feb. 13, 2008
LISN ROHDE & SCHWARZ	ESH2-Z5	100104	Sep. 14, 2007
Software ADT	ADT_Cond_V3	NA	NA

- NOTE:**
1. The calibration interval of the above test instruments is 12 months and the calibrations are traceable to NML/ROC and NIST/USA.
  2. The test was performed in HwaYa Shielded Room 1.
  3. The VCCI Site Registration No. is C-2040.



#### 4.1.3 TEST PROCEDURES

- a. The EUT was placed 0.4 meters from the conducting wall of the shielded room with EUT being connected to the power mains through a line impedance stabilization network (LISN). Other support units were connected to the power mains through another LISN. The two LISNs provide 50 ohm/ 50uH of coupling impedance for the measuring instrument.
- b. Both lines of the power mains connected to the EUT were checked for maximum conducted interference.
- c. The frequency range from 150kHz to 30MHz was searched. Emission levels under (Limit - 20dB) was not recorded.

#### 4.1.4 DEVIATION FROM TEST STANDARD

No deviation

#### 4.1.5 TEST SETUP

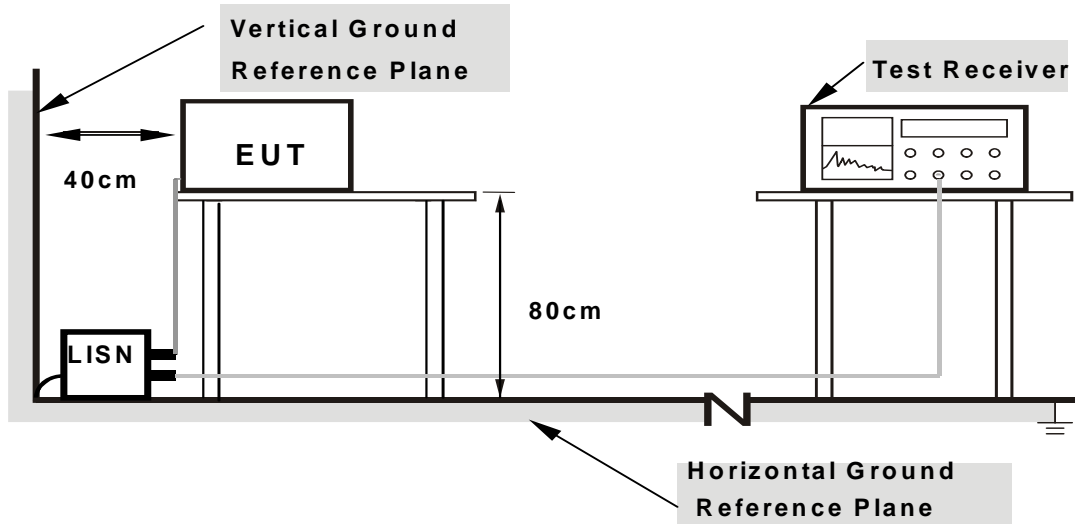

**Note: 1.Support units were connected to second LISN.**

**2.Both of LISNs (AMN) are 80 cm from EUT and at least 80 from other units and other metal planes**

For the actual test configuration, please refer to the related item – Photographs of the Test Configuration.

#### 4.1.6 EUT OPERATING CONDITIONS

- a. Placed the EUT on a testing table.
- b. Prepared a notebook computer and placed it outside of testing area to act as communication partner for EUT.
- c. The EUT ran a test program (provided by manufacturer) to enable all functions under transmission condition continuously at specific channel frequency.
- d. The necessary accessories enable the EUT in full functions.

#### 4.1.7 TEST RESULTS

##### Conducted Worst-Case Data

EUT TEST CONDITION		MEASUREMENT DETAIL	
CHANNEL	Channel 4	PHASE	Line 1
MODULATION TYPE	BPSK	6dB BANDWIDTH	9 kHz
TRANSFER RATE	6Mbps	ENVIRONMENTAL CONDITIONS	25deg. C, 68%RH, 991hPa
INPUT POWER (SYSTEM)	120Vac, 60 Hz	TEST MODE	A
TESTED BY	Morgan Chen		

No	Freq. [MHz]	Corr. Factor [dB]	Reading Value [dB (uV)]		Emission Level [dB (uV)]		Limit [dB (uV)]		Margin (dB)	
			Q.P.	AV.	Q.P.	AV.	Q.P.	AV.	Q.P.	AV.
1	0.201	0.21	51.96	-	52.17	-	63.58	53.58	-11.41	-
2	0.267	0.21	47.32	-	47.53	-	61.20	51.20	-13.67	-
3	0.334	0.21	39.44	-	39.65	-	59.36	49.36	-19.71	-
4	0.408	0.21	36.20	-	36.41	-	57.69	47.69	-21.28	-
5	1.281	0.25	31.35	-	31.60	-	56.00	46.00	-24.40	-
6	3.633	0.37	32.29	-	32.66	-	56.00	46.00	-23.34	-

- REMARKS:**
1. Q.P. and AV. are abbreviations of quasi-peak and average individually.
  2. "-": The Quasi-peak reading value also meets average limit and measurement with the average detector is unnecessary.
  3. The emission levels of other frequencies were very low against the limit.
  4. Margin value = Emission level - Limit value
  5. Correction factor = Insertion loss + Cable loss
  6. Emission Level = Correction Factor + Reading Value.

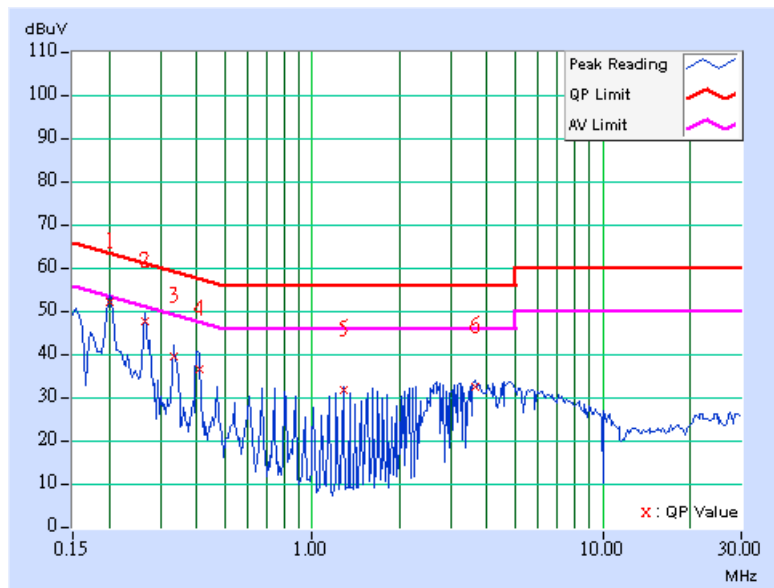

EUT TEST CONDITION		MEASUREMENT DETAIL	
CHANNEL	Channel 4	PHASE	Line 2
MODULATION TYPE	BPSK	6dB BANDWIDTH	9 kHz
TRANSFER RATE	6Mbps	ENVIRONMENTAL CONDITIONS	25deg. C, 68%RH, 991hPa
INPUT POWER (SYSTEM)	120Vac, 60 Hz	TEST MODE	A
TESTED BY	Morgan Chen		

No	Freq. [MHz]	Corr. Factor [dB]	Reading Value [dB (uV)]		Emission Level [dB (uV)]		Limit [dB (uV)]		Margin (dB)	
			Q.P.	AV.	Q.P.	AV.	Q.P.	AV.	Q.P.	AV.
1	0.201	0.21	52.04	-	52.25	-	63.58	53.58	-11.33	-
2	0.271	0.21	47.43	-	47.64	-	61.08	51.08	-13.44	-
3	0.338	0.21	40.65	-	40.86	-	59.26	49.26	-18.40	-
4	0.404	0.21	39.66	-	39.87	-	57.77	47.77	-17.90	-
5	1.211	0.24	31.63	-	31.87	-	56.00	46.00	-24.13	-
6	1.684	0.25	31.94	-	32.19	-	56.00	46.00	-23.81	-

- REMARKS:**
1. Q.P. and AV. are abbreviations of quasi-peak and average individually.
  2. "-": The Quasi-peak reading value also meets average limit and measurement with the average detector is unnecessary.
  3. The emission levels of other frequencies were very low against the limit.
  4. Margin value = Emission level - Limit value
  5. Correction factor = Insertion loss + Cable loss
  6. Emission Level = Correction Factor + Reading Value.

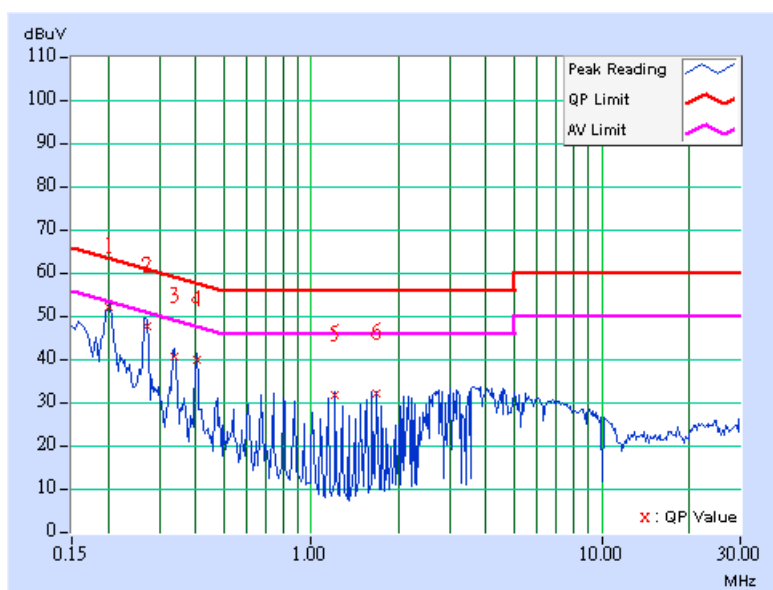



EUT TEST CONDITION		MEASUREMENT DETAIL	
CHANNEL	Channel 4	PHASE	Line 1
MODULATION TYPE	BPSK	6dB BANDWIDTH	9 kHz
TRANSFER RATE	6Mbps	ENVIRONMENTAL CONDITIONS	25deg. C, 68%RH, 991hPa
INPUT POWER (SYSTEM)	120Vac, 60 Hz	TEST MODE	B
TESTED BY	Morgan Chen		

No	Freq. [MHz]	Corr. Factor [dB]	Reading Value [dB (uV)]		Emission Level [dB (uV)]		Limit [dB (uV)]		Margin (dB)	
			Q.P.	AV.	Q.P.	AV.	Q.P.	AV.	Q.P.	AV.
			1	0.240	0.21	40.30	-	40.51	-	62.10
2	0.365	0.21	32.56	-	32.77	-	58.62	48.62	-25.85	-
3	2.406	0.29	37.29	-	37.58	-	56.00	46.00	-18.42	-
4	11.492	0.60	34.13	-	34.73	-	60.00	50.00	-25.27	-
5	23.129	1.29	42.62	-	43.91	-	60.00	50.00	-16.09	-
6	26.488	1.60	40.62	-	42.22	-	60.00	50.00	-17.78	-

- REMARKS:**
1. Q.P. and AV. are abbreviations of quasi-peak and average individually.
  2. "-": The Quasi-peak reading value also meets average limit and measurement with the average detector is unnecessary.
  3. The emission levels of other frequencies were very low against the limit.
  4. Margin value = Emission level - Limit value
  5. Correction factor = Insertion loss + Cable loss
  6. Emission Level = Correction Factor + Reading Value.

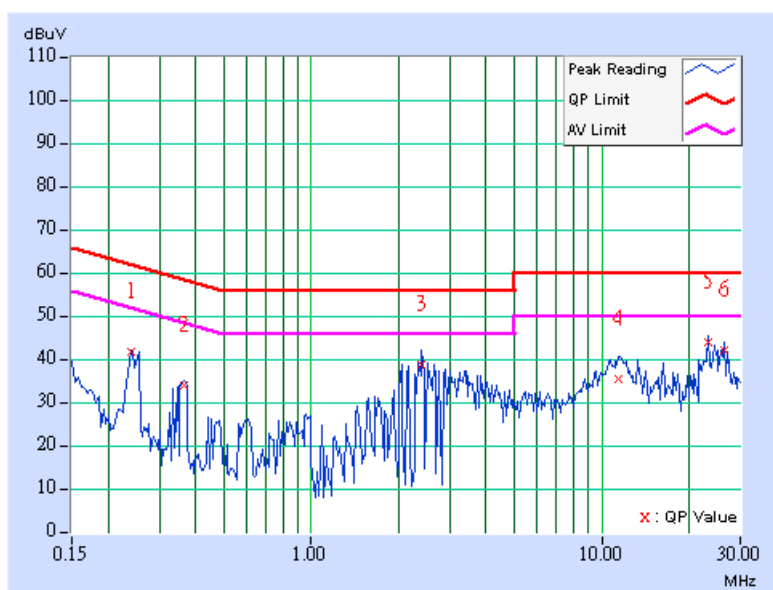

EUT TEST CONDITION		MEASUREMENT DETAIL	
CHANNEL	Channel 4	PHASE	Line 2
MODULATION TYPE	BPSK	6dB BANDWIDTH	9 kHz
TRANSFER RATE	6Mbps	ENVIRONMENTAL CONDITIONS	25deg. C, 68%RH, 991hPa
INPUT POWER (SYSTEM)	120Vac, 60 Hz	TEST MODE	B
TESTED BY	Morgan Chen		

No	Freq. [MHz]	Corr. Factor [dB]	Reading Value [dB (uV)]		Emission Level [dB (uV)]		Limit [dB (uV)]		Margin (dB)	
			Q.P.	AV.	Q.P.	AV.	Q.P.	AV.	Q.P.	AV.
1	0.240	0.21	35.97	-	36.18	-	62.10	52.10	-25.92	-
2	0.486	0.21	32.35	-	32.56	-	56.24	46.24	-23.67	-
3	1.789	0.26	22.27	-	22.53	-	56.00	46.00	-33.47	-
4	2.652	0.30	37.37	-	37.67	-	56.00	46.00	-18.33	-
5	11.605	0.51	34.86	-	35.37	-	60.00	50.00	-24.63	-
6	23.129	0.54	39.93	-	40.47	-	60.00	50.00	-19.53	-

- REMARKS:**
1. Q.P. and AV. are abbreviations of quasi-peak and average individually.
  2. "-": The Quasi-peak reading value also meets average limit and measurement with the average detector is unnecessary.
  3. The emission levels of other frequencies were very low against the limit.
  4. Margin value = Emission level - Limit value
  5. Correction factor = Insertion loss + Cable loss
  6. Emission Level = Correction Factor + Reading Value.

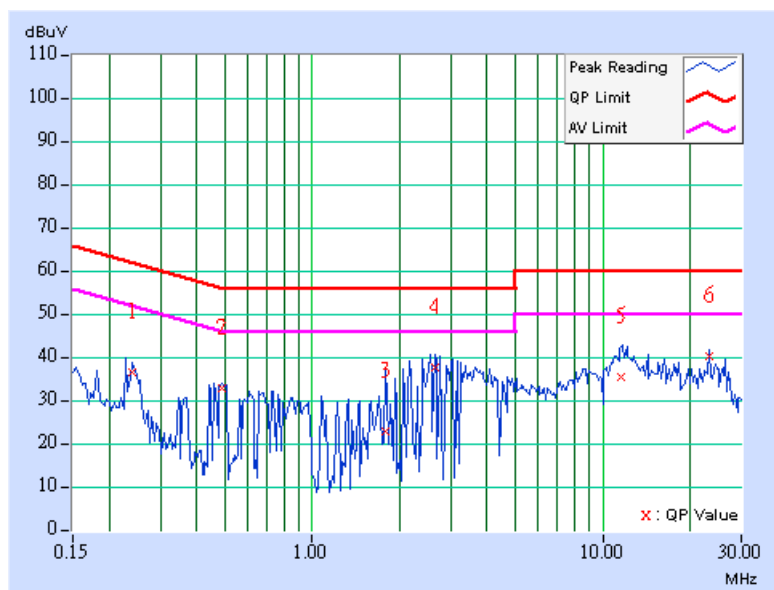

## 4.2 RADIATED EMISSION MEASUREMENT

### 4.2.1 LIMITS OF RADIATED EMISSION MEASUREMENT

Emissions radiated outside of the specified bands, shall be according to the general radiated limits in 15.209 as following:

Frequencies (MHz)	Field strength (microvolts/meter)	Measurement distance (meters)
0.009-0.490	2400/F(kHz)	300
0.490-1.705	24000/F(kHz)	30
1.705-30.0	30	30
30-88	100	3
88-216	150	3
216-960	200	3
Above 960	500	3

**NOTE:**

1. The lower limit shall apply at the transition frequencies.
2. Emission level (dBuV/m) = 20 log Emission level (uV/m).
3. As shown in 15.35(b), for frequencies above 1000MHz, the field strength limits are based on average detector, however, the peak field strength of any emission shall not exceed the maximum permitted average limits, specified above by more than 20dB under any condition of modulation.

### 4.2.2 LIMITS OF UNWANTED EMISSION OUT OF THE RESTRICTED BANDS

Frequencies (MHz)	EIRP Limit (dBm)	Equivalent Field Strength at 3m (dBµV/m) *note 3
5150~5250	-27	68.3
5250~5350	-27	68.3
5725~5825	-27 *note 1	68.3
	-17 *note 2	78.3

**NOTE:**

1. For frequencies 10MHz or greater above or below the band edge.
2. All emissions within the frequency range from the band edge to 10MHz above or below the band edge.
3. The following formula is used to convert the equipment isotropic radiated power (eirp) to field strength

$$E = \frac{1000000\sqrt{30P}}{3} \mu\text{V/m, where P is the eirp (Watts)}$$



#### 4.2.3 TEST INSTRUMENTS

DESCRIPTION & MANUFACTURER	MODEL NO.	SERIAL NO.	CALIBRATED UNTIL
Test Receiver ROHDE & SCHWARZ	ESI7	838496/016	Dec. 29, 2007
Spectrum Analyzer ROHDE & SCHWARZ	FSP40	100039	Dec. 01, 2007
BILOG Antenna SCHWARZBECK	VULB9168	9168-155	Jan. 04, 2008
HORN Antenna SCHWARZBECK	BBHA 9120D	9120D-405	Dec. 18, 2007
HORN Antenna SCHWARZBECK	BBHA 9170	BBHA9170242	Jan. 16, 2008
Preamplifier Agilent	8449B	3008A1960	Oct. 30, 2007
Preamplifier Agilent	8447D	2944A10631	Oct. 30, 2007
RF signal cable HUBER+SUHNNER	SUCOFLEX 104	230128/4	Nov. 14, 2007
RF signal cable HUBER+SUHNNER	SUCOFLEX 104	233233/4	Nov. 14, 2007
Software ADT.	ADT_Radiated_V7.6	NA	NA
Antenna Tower inn-co GmbH	MA 4000	010303	NA
Antenna Tower Controller inn-co GmbH	CO2000	019303	NA
Turn Table ADT.	TT100.	TT93021704	NA
Turn Table Controller ADT.	SC100.	SC93021704	NA

- NOTE:**
1. The calibration interval of the above test instruments is 12 months and the calibrations are traceable to NML/ROC and NIST/USA.
  2. The test was performed in HwaYa Chamber 4.
  3. The horn antenna and HP preamplifier (model: 8449B) are used only for the measurement of emission frequency above 1GHz if tested.
  4. The IC Site Registration No. is IC3789B-4.

#### 4.2.4 TEST PROCEDURES

- a. The EUT was placed on the top of a rotating table 0.8 meters above the ground at a 3 meter semi-anechoic chamber. The table was rotated 360 degrees to determine the position of the highest radiation.
- b. The EUT was set 3 meters away from the interference-receiving antenna, which was mounted on the top of a variable-height antenna tower.
- c. The antenna is a broadband antenna, and its height is varied from one meter to four meters above the ground to determine the maximum value of the field strength. Both horizontal and vertical polarizations of the antenna are set to make the measurement.
- d. For each suspected emission, the EUT was arranged to its worst case and then the antenna was tuned to heights from 1 meter to 4 meters and the rotatable table was turned from 0 degrees to 360 degrees to find the maximum reading.
- e. The test-receiver system was set to Peak Detect Function and Specified Bandwidth with Maximum Hold Mode.
- f. If the emission level of the EUT in peak mode was 10dB lower than the limit specified, then testing could be stopped and the peak values of the EUT would be reported. Otherwise the emissions that did not have 10dB margin would be re-tested one by one using peak, quasi-peak or average method as specified and then reported in a data sheet.

**NOTE:**

1. The resolution bandwidth and video bandwidth of test receiver/spectrum analyzer is 120kHz for Peak detection (PK) and Quasi-peak detection (QP) at frequency below 1GHz.
2. The resolution bandwidth of test receiver/spectrum analyzer is 1 MHz and video bandwidth is 3MHz for Peak detection at frequency above 1GHz.
3. The resolution bandwidth of test receiver/spectrum analyzer is 1 MHz and the video bandwidth is 1kHz for Average detection (AV) at frequency above 1GHz.

#### 4.2.5 DEVIATION FROM TEST STANDARD

No deviation

#### 4.2.6 TEST SETUP

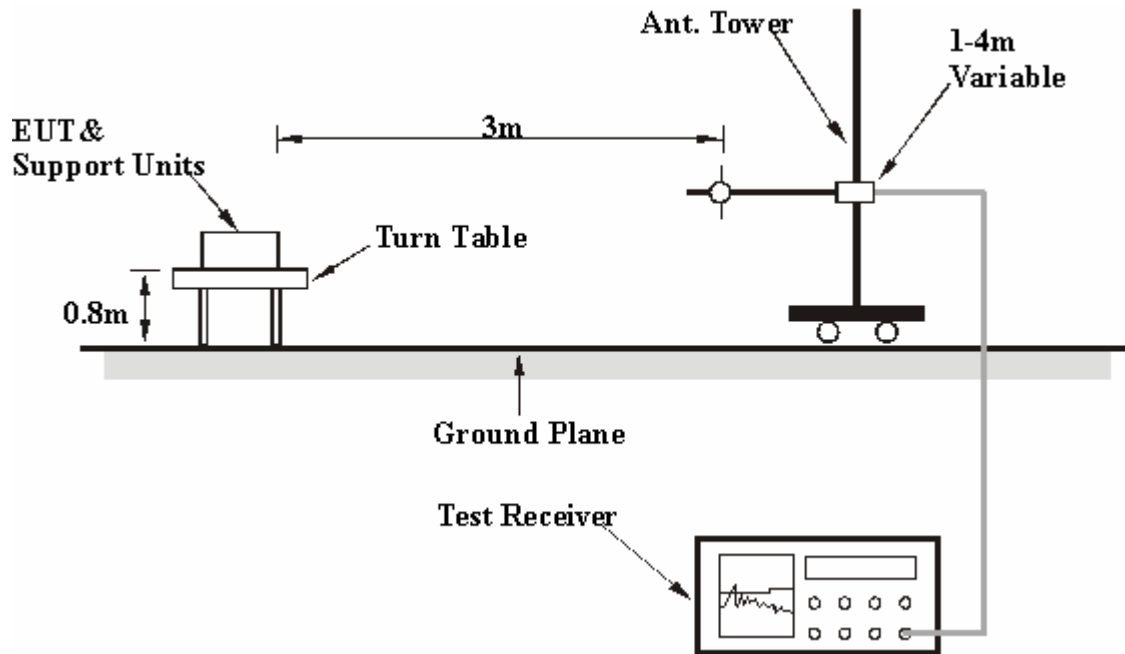

For the actual test configuration, please refer to the attached file (Test Setup Photo).

#### 4.2.7 EUT OPERATING CONDITION

Same as 4.1.6



## 4.2.8 TEST RESULTS

### Below 1GHz Worst-Case Data

EUT TEST CONDITION		MEASUREMENT DETAIL	
CHANNEL	Channel 4	FREQUENCY RANGE	Below 1000MHz
MODULATION TYPE	BPSK	DETECTOR FUNCTION	Quasi-Peak
TRANSFER RATE	6Mbps	ENVIRONMENTAL CONDITIONS	25deg. C, 65%RH, 991hPa
INPUT POWER (SYSTEM)	120Vac, 60 Hz	TEST MODE	A
TESTED BY	Morgan Chen		

ANTENNA POLARITY & TEST DISTANCE: HORIZONTAL AT 3 M								
No.	Freq. (MHz)	Emission Level (dBuV/m)	Limit (dBuV/m)	Margin (dB)	Antenna Height (m)	Table Angle (Degree)	Raw Value (dBuV)	Correction Factor (dB/m)
1	113.50	33.84 QP	43.50	-9.66	1.50 H	331	22.31	11.53
2	129.06	31.43 QP	43.50	-12.07	1.50 H	316	18.66	12.77
3	164.06	30.42 QP	43.50	-13.08	1.50 H	289	16.31	14.11
4	440.14	33.44 QP	46.00	-12.56	1.00 H	229	14.85	18.59
5	751.23	39.37 QP	46.00	-6.63	1.00 H	46	13.53	25.85
6	770.67	32.77 QP	46.00	-13.23	1.00 H	187	6.69	26.08
7	881.50	35.40 QP	46.00	-10.60	1.00 H	37	7.75	27.66

ANTENNA POLARITY & TEST DISTANCE: VERTICAL AT 3 M								
No.	Freq. (MHz)	Emission Level (dBuV/m)	Limit (dBuV/m)	Margin (dB)	Antenna Height (m)	Table Angle (Degree)	Raw Value (dBuV)	Correction Factor (dB/m)
1	53.23	33.01 QP	40.00	-6.99	1.00 V	10	18.85	14.17
2	62.95	30.11 QP	40.00	-9.89	1.00 V	331	16.74	13.37
3	115.45	36.02 QP	43.50	-7.48	1.00 V	319	24.28	11.74
4	131.00	33.82 QP	43.50	-9.68	1.00 V	349	20.93	12.88
5	751.23	37.11 QP	46.00	-8.89	1.50 V	229	11.26	25.85
6	770.67	34.23 QP	46.00	-11.77	1.50 V	244	8.16	26.08
7	881.50	33.17 QP	46.00	-12.83	1.00 V	253	5.51	27.66

- REMARKS:**
1. Emission level(dBuV/m)=Raw Value(dBuV) + Correction Factor(dB/m)
  2. Correction Factor(dB/m) = Antenna Factor (dB/m) + Cable Factor (dB)
  3. The other emission levels were very low against the limit.
  4. Margin value = Emission level – Limit value.



EUT TEST CONDITION		MEASUREMENT DETAIL	
CHANNEL	Channel 4	FREQUENCY RANGE	Below 1000MHz
MODULATION TYPE	BPSK	DETECTOR FUNCTION	Quasi-Peak
TRANSFER RATE	6Mbps	ENVIRONMENTAL CONDITIONS	25deg. C, 65%RH, 991hPa
INPUT POWER (SYSTEM)	120Vac, 60 Hz	TEST MODE	B
TESTED BY	Morgan Chen		

ANTENNA POLARITY & TEST DISTANCE: HORIZONTAL AT 3 M								
No.	Freq. (MHz)	Emission Level (dBuV/m)	Limit (dBuV/m)	Margin (dB)	Antenna Height (m)	Table Angle (Degree)	Raw Value (dBuV)	Correction Factor (dB/m)
1	53.23	32.27 QP	40.00	-7.73	1.50 H	79	18.10	14.17
2	109.62	35.63 QP	43.50	-7.87	1.50 H	307	24.51	11.12
3	142.67	35.83 QP	43.50	-7.67	1.50 H	79	22.01	13.81
4	249.60	33.80 QP	46.00	-12.20	1.50 H	292	20.12	13.69
5	751.23	39.05 QP	46.00	-6.95	1.00 H	46	13.21	25.85
6	770.67	32.98 QP	46.00	-13.02	1.00 H	175	6.91	26.08
7	858.17	34.79 QP	46.00	-11.21	1.50 H	325	7.50	27.28
8	881.50	32.59 QP	46.00	-13.41	1.00 H	10	4.93	27.66
9	937.88	33.35 QP	46.00	-12.65	1.50 H	289	4.97	28.38

ANTENNA POLARITY & TEST DISTANCE: VERTICAL AT 3 M								
No.	Freq. (MHz)	Emission Level (dBuV/m)	Limit (dBuV/m)	Margin (dB)	Antenna Height (m)	Table Angle (Degree)	Raw Value (dBuV)	Correction Factor (dB/m)
1	51.29	34.94 QP	40.00	-5.06	1.00 V	13	20.69	14.25
2	109.62	30.99 QP	43.50	-12.51	1.00 V	232	19.88	11.12
3	162.11	33.17 QP	43.50	-10.33	1.50 V	127	18.96	14.21
4	751.23	35.26 QP	46.00	-10.74	1.50 V	10	9.42	25.85
5	770.67	33.72 QP	46.00	-12.28	1.50 V	262	7.64	26.08
6	858.17	34.16 QP	46.00	-11.84	1.00 V	10	6.88	27.28
7	881.50	33.54 QP	46.00	-12.46	1.00 V	250	5.88	27.66
8	957.33	32.25 QP	46.00	-13.75	1.00 V	10	3.63	28.62

- REMARKS:**
1. Emission level(dBuV/m)=Raw Value(dBuV) + Correction Factor(dB/m)
  2. Correction Factor(dB/m) = Antenna Factor (dB/m) + Cable Factor (dB)
  3. The other emission levels were very low against the limit.
  4. Margin value = Emission level – Limit value.





**802.11a OFDM modulation**

EUT TEST CONDITION		MEASUREMENT DETAIL	
CHANNEL	Channel 1	FREQUENCY RANGE	1 ~ 40 GHz
MODULATION TYPE	BPSK	DETECTOR FUNCTION	Peak(PK) Average (AV)
TRANSFER RATE	6Mbps	ENVIRONMENTAL CONDITIONS	25deg. C, 65%RH, 991hPa
INPUT POWER (SYSTEM)	120Vac, 60 Hz	TESTED BY	Brad Wu

ANTENNA POLARITY & TEST DISTANCE: HORIZONTAL AT 3 M								
No.	Freq. (MHz)	Emission Level (dBuV/m)	Limit (dBuV/m)	Margin (dB)	Antenna Height (m)	Table Angle (Degree)	Raw Value (dBuV)	Correction Factor (dB/m)
1	#5150.00	62.11 PK	74.00	-11.89	1.42 H	305	22.96	39.15
2	#5150.00	43.45 AV	54.00	-10.55	1.42 H	305	4.30	39.15
3	*5180.00	100.54 PK			1.42 H	305	61.34	39.20
4	*5180.00	89.93 AV			1.42 H	305	50.73	39.20
5	10360.00	60.08 PK	68.30	-8.22	1.42 H	76	10.39	49.69

ANTENNA POLARITY & TEST DISTANCE: VERTICAL AT 3 M								
No.	Freq. (MHz)	Emission Level (dBuV/m)	Limit (dBuV/m)	Margin (dB)	Antenna Height (m)	Table Angle (Degree)	Raw Value (dBuV)	Correction Factor (dB/m)
1	#5150.00	65.05 PK	74.00	-8.95	1.36 V	286	25.90	39.15
2	#5150.00	47.92 AV	54.00	-6.08	1.36 V	286	8.77	39.15
3	*5180.00	109.33 PK			1.36 V	286	70.13	39.20
4	*5180.00	97.60 AV			1.36 V	286	58.40	39.20
5	10360.00	64.29 PK	68.30	-4.01	1.34 V	147	14.60	49.69

- NOTE:**
1. Emission level(dBuV/m)=Raw Value(dBuV) + Correction Factor(dB/m)
  2. Correction Factor(dB/m) = Antenna Factor (dB/m) + Cable Factor (dB)
  3. The other emission levels were very low against the limit.
  4. Margin value = Emission level – Limit value
  5. "\*" : Fundamental frequency
  6. "#"The radiated frequency falling in the restricted band.



EUT TEST CONDITION		MEASUREMENT DETAIL	
CHANNEL	Channel 2	FREQUENCY RANGE	1 ~ 40 GHz
MODULATION TYPE	BPSK	DETECTOR FUNCTION	Peak(PK) Average (AV)
TRANSFER RATE	6Mbps	ENVIRONMENTAL CONDITIONS	23deg. C, 63%RH, 991hPa
INPUT POWER (SYSTEM)	120Vac, 60 Hz	TESTED BY	Brad Wu

ANTENNA POLARITY & TEST DISTANCE: HORIZONTAL AT 3 M								
No.	Freq. (MHz)	Emission Level (dBuV/m)	Limit (dBuV/m)	Margin (dB)	Antenna Height (m)	Table Angle (Degree)	Raw Value (dBuV)	Correction Factor (dB/m)
1	*5200.00	103.95 PK			1.25 H	336	64.71	39.24
2	*5200.00	92.63 AV			1.25 H	336	53.39	39.24
3	10400.00	63.07 PK	68.30	-5.23	1.04 H	47	13.22	49.85

ANTENNA POLARITY & TEST DISTANCE: VERTICAL AT 3 M								
No.	Freq. (MHz)	Emission Level (dBuV/m)	Limit (dBuV/m)	Margin (dB)	Antenna Height (m)	Table Angle (Degree)	Raw Value (dBuV)	Correction Factor (dB/m)
1	*5200.00	112.79 PK			1.33 V	103	73.55	39.24
2	*5200.00	101.42 AV			1.33 V	103	62.18	39.24
3	10400.00	66.14 PK	68.30	-2.16	1.89 V	324	16.29	49.85

- NOTE:**
1. Emission level(dBuV/m)=Raw Value(dBuV) + Correction Factor(dB/m)
  2. Correction Factor(dB/m) = Antenna Factor (dB/m) + Cable Factor (dB)
  3. The other emission levels were very low against the limit.
  4. Margin value = Emission level – Limit value
  5. "\*" : Fundamental frequency
  6. "#"The radiated frequency falling in the restricted band.



EUT TEST CONDITION		MEASUREMENT DETAIL	
CHANNEL	Channel 4	FREQUENCY RANGE	1 ~ 40 GHz
MODULATION TYPE	BPSK	DETECTOR FUNCTION	Peak(PK) Average (AV)
TRANSFER RATE	6Mbps	ENVIRONMENTAL CONDITIONS	23deg. C, 63%RH, 991hPa
INPUT POWER (SYSTEM)	120Vac, 60 Hz	TESTED BY	Brad Wu

ANTENNA POLARITY & TEST DISTANCE: HORIZONTAL AT 3 M								
No.	Freq. (MHz)	Emission Level (dBuV/m)	Limit (dBuV/m)	Margin (dB)	Antenna Height (m)	Table Angle (Degree)	Raw Value (dBuV)	Correction Factor (dB/m)
1	*5240.00	103.86 PK			1.54 H	12	64.53	39.33
2	*5240.00	92.45 AV			1.54 H	12	53.12	39.33
3	10480.00	59.64 PK	68.30	-8.66	1.48 H	211	9.62	50.02

ANTENNA POLARITY & TEST DISTANCE: VERTICAL AT 3 M								
No.	Freq. (MHz)	Emission Level (dBuV/m)	Limit (dBuV/m)	Margin (dB)	Antenna Height (m)	Table Angle (Degree)	Raw Value (dBuV)	Correction Factor (dB/m)
1	*/5240.00	112.49 PK			1.56 V	241	73.16	39.33
2	*5240.00	101.27 AV			1.56 V	241	61.94	39.33
3	10480.00	64.50 PK	68.30	-3.80	1.55 V	145	14.48	50.02

- NOTE:**
1. Emission level(dBuV/m)=Raw Value(dBuV) + Correction Factor(dB/m)
  2. Correction Factor(dB/m) = Antenna Factor (dB/m) + Cable Factor (dB)
  3. The other emission levels were very low against the limit.
  4. Margin value = Emission level – Limit value
  5. "\*" : Fundamental frequency
  6. "#" The radiated frequency falling in the restricted band.



### 4.3 PEAK TRANSMIT POWER MEASUREMENT

#### 4.3.1 LIMITS OF PEAK TRANSMIT POWER MEASUREMENT

Frequency Band	Limit
5.15 ~ 5.25GHz	The lesser of 50mW (17dBm) or 4dBm + 10logB
5.25 ~ 5.35GHz	The lesser of 250mW (24dBm) or 11dBm + 10logB
5.725 ~ 5.825GHz	The lesser of 1W (30dBm) or 17dBm + 10logB

**NOTE:** Where B is the 26dB emission bandwidth in MHz.

#### 4.3.2 TEST INSTRUMENTS

Description & Manufacturer	Model No.	Serial No.	Calibrated Until
SPECTRUM ANALYZER	FSP40	100040	Jun. 28, 2008

**NOTE:** The calibration interval of the above test instruments is 12 months and the calibrations are traceable to NML/ROC and NIST/USA.

#### 4.3.3 TEST PROCEDURE

1. The transmitter output was connected to the spectrum analyzer.
2. Set span to encompass the entire emission bandwidth of the signal.
3. Set RBW to 1MHz, VBW to 300kHz.
4. Using the spectrum analyzer's channel power measurement function to measure the output power.

**NOTE:**

The test is performed in accordance with FCC Public Notice: APPENDIX A Guidelines for Assessing Unlicensed National Information Infrastructure (U-NII) Devices – Part 15, Subpart E, August 2002.

The transmitter output operates continuously therefore Method # 1 is used.

#### 4.3.4 DEVIATION FROM TEST STANDARD

No deviation

#### 4.3.5 TEST SETUP

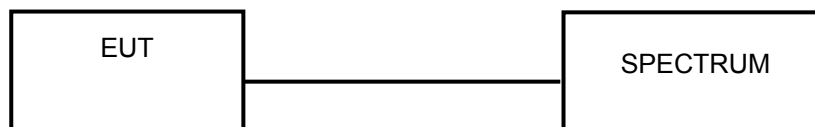

#### 4.3.6 EUT OPERATING CONDITIONS

The software provided by client to enable the EUT under transmission condition continuously at specific channel frequencies individually.



#### 4.3.7 TEST RESULTS

##### 802.11a OFDM Modulation

<b>MODULATION TYPE</b>	BPSK	<b>TRANSFER RATE</b>	6Mbps
<b>INPUT POWER (SYSTEM)</b>	120Vac, 60 Hz	<b>ENVIRONMENTAL CONDITIONS</b>	26deg.C, 67%RH, 991hPa
<b>TESTED BY</b>	Long Chen		

CHANNEL	CHANNEL FREQUENCY (MHz)	PEAK POWER OUTPUT (mW)	PEAK POWER OUTPUT (dBm)	PEAK POWER LIMIT (dBm)	26dBc Occupied Bandwidth (MHz)	PASS/FAIL
1	5180	23.014	13.62	17.00	24.67	PASS
2	5200	40.087	16.03	17.00	23.80	PASS
4	5240	40.365	16.06	17.00	23.53	PASS

**NOTE:** The 26dBc Occupied Bandwidth plot, please refer to the following pages.



## Peak Power Output: CH 1

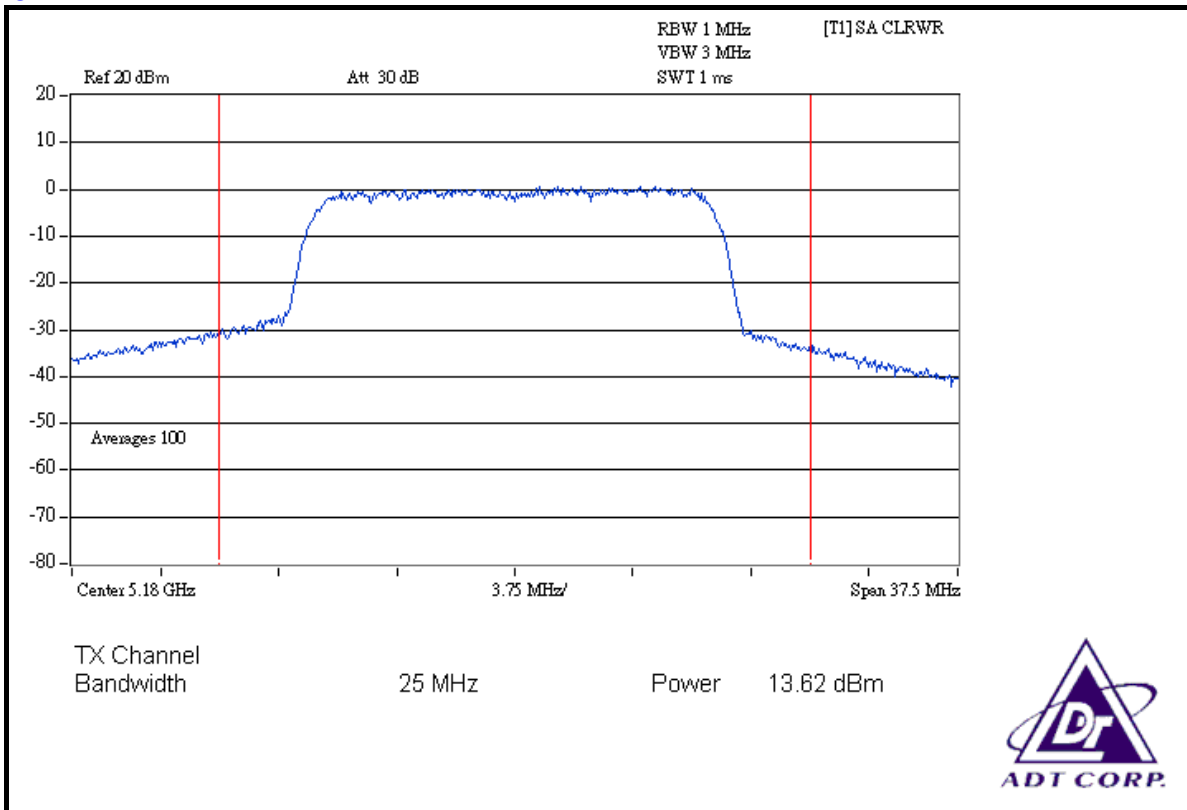

## CH 2

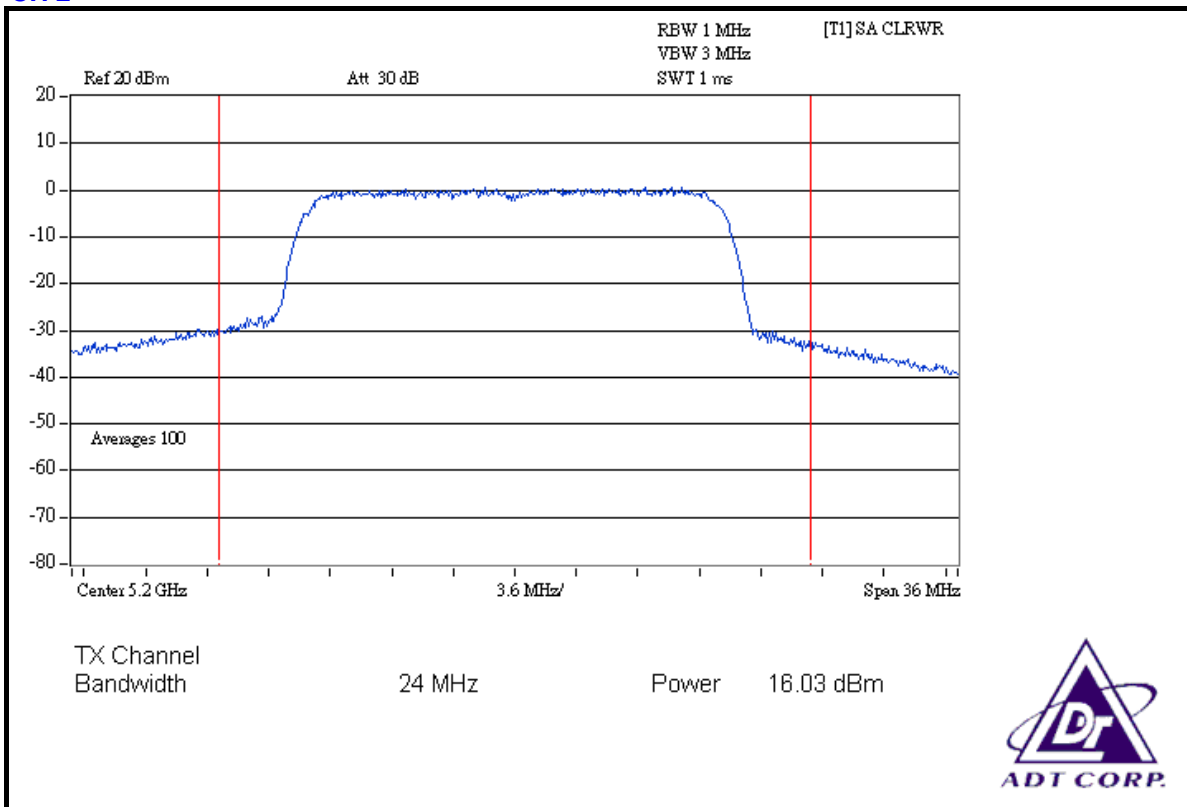



### CH 4

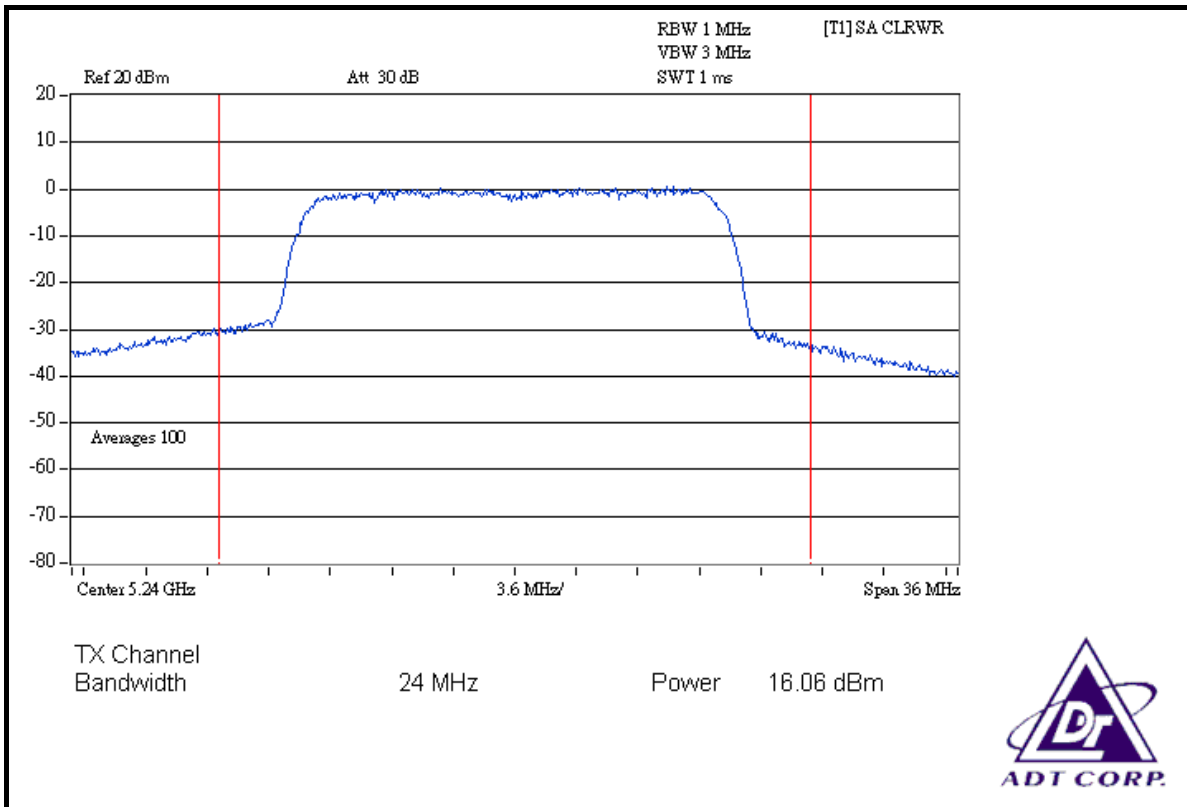

### 26dB Occupied Bandwidth: CH 1

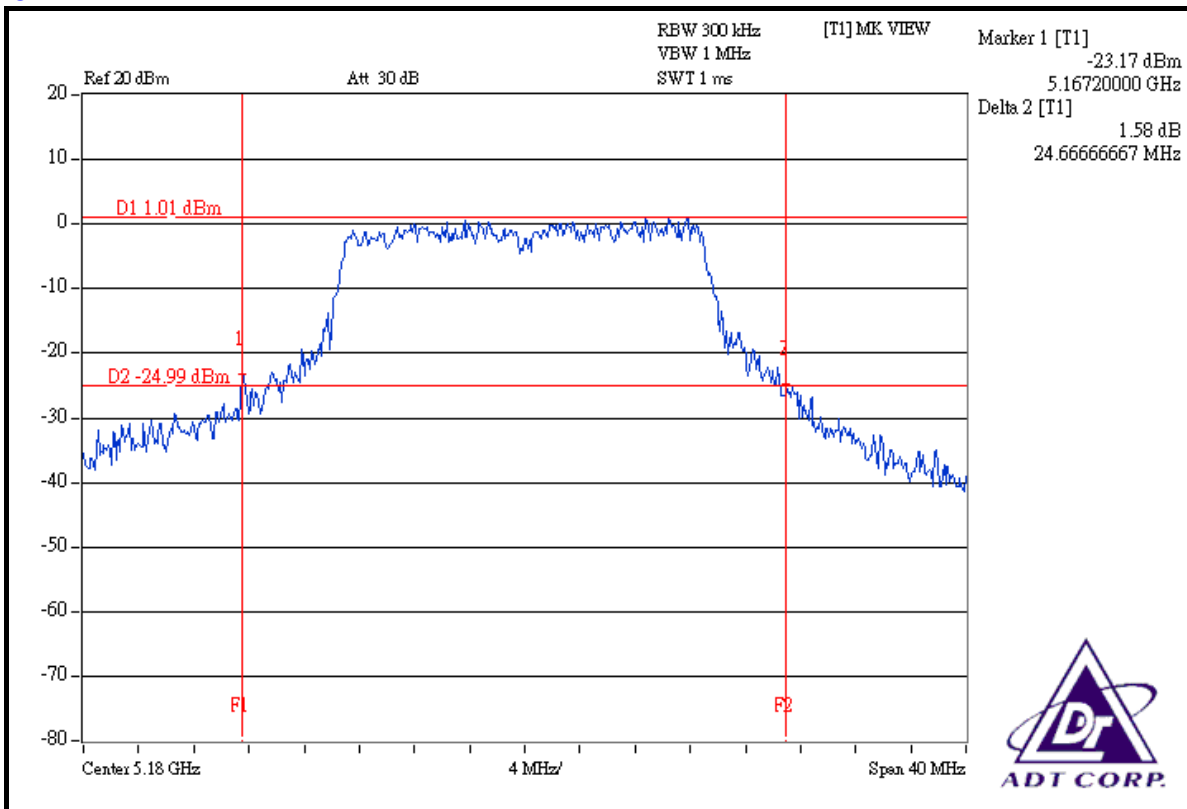





### CH 2

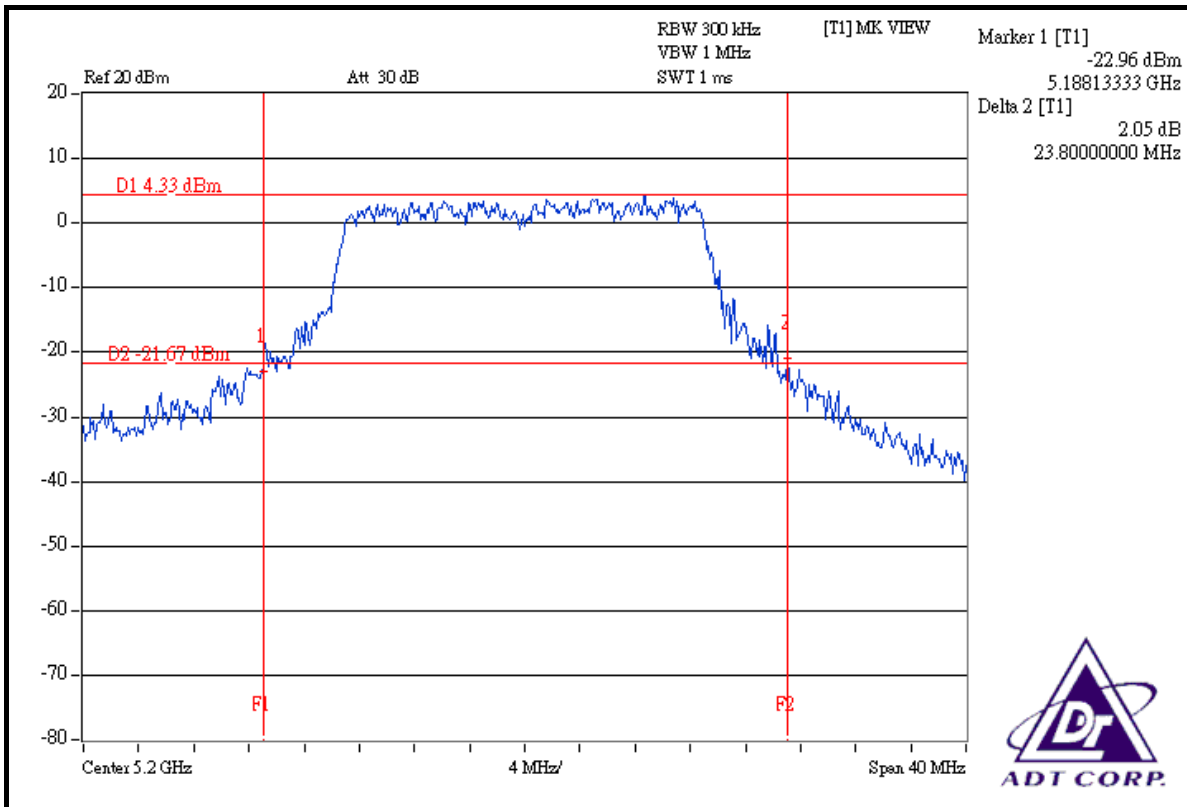

### CH 4

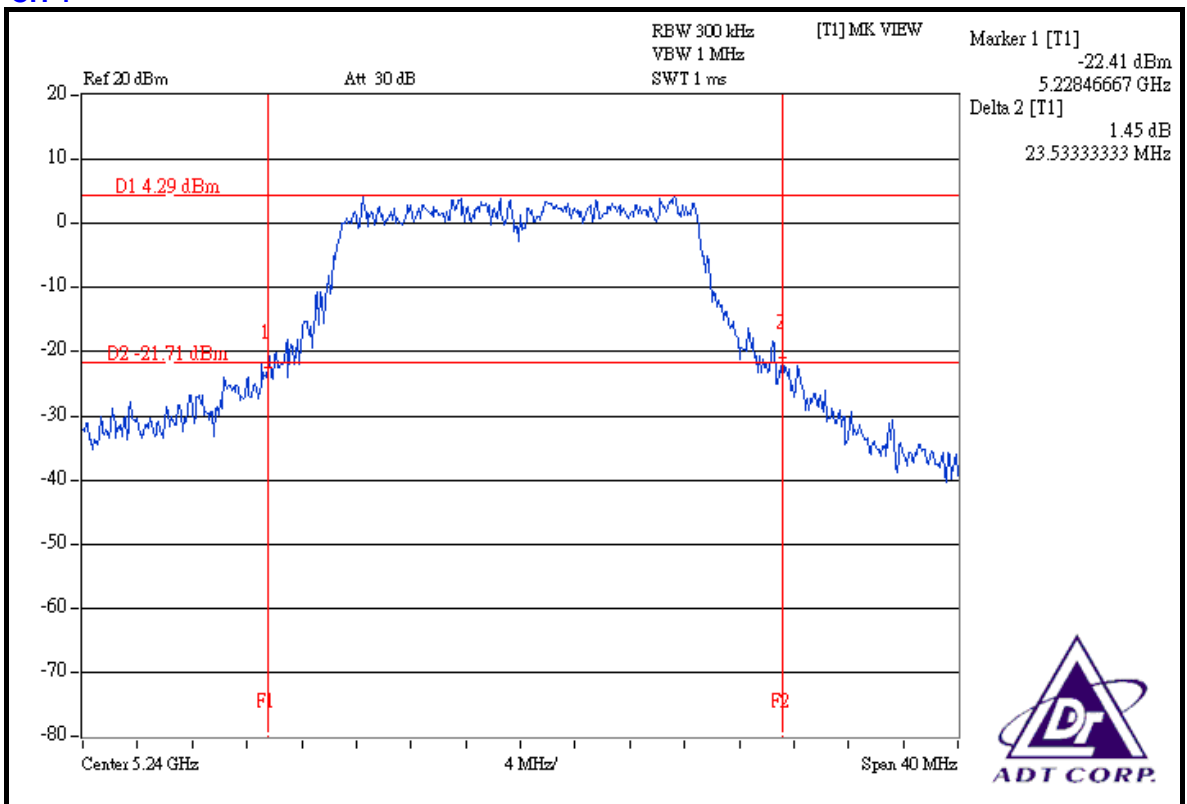



#### 4.4 PEAK POWER EXCURSION MEASUREMENT

##### 4.4.1 LIMITS OF PEAK POWER EXCURSION MEASUREMENT

Frequency Band	Limit
5.15 ~ 5.25 GHz	13dB
5.25 ~ 5.35 GHz	13dB
5.725 ~ 5.825 GHz	13dB

##### 4.4.2 TEST INSTRUMENTS

Description & Manufacturer	Model No.	Serial No.	Calibrated Until
SPECTRUM ANALYZER	FSP40	100040	Jun. 28, 2008

**NOTE:** The calibration interval of the above test instruments is 12 months and the calibrations are traceable to NML/ROC and NIST/USA.

#### 4.4.3 TEST PROCEDURE

1. The transmitter output was connected to the spectrum analyzer.
2. Set the spectrum bandwidth span to view the entire spectrum.
3. Using peak detector and Max-hold function for Trace 1 (RB=1MHz, VB=3MHz) and 2 (RB=1MHz, VB=300kHz).
4. The largest difference between Trace 1 and Trace 2 in any 1MHz band on any frequency was recorded.

#### 4.4.4 DEVIATION FROM TEST STANDARD

No deviation

#### 4.4.5 TEST SETUP

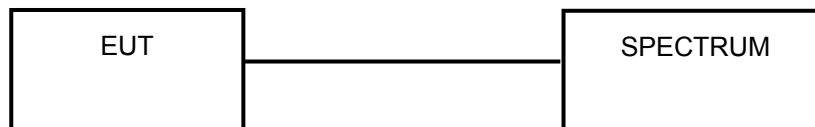

#### 4.4.6 EUT OPERATING CONDITIONS

The software provided by client to enable the EUT under transmission condition continuously at specific channel frequencies individually.



#### 4.4.7 TEST RESULTS

##### 802.11a OFDM modulation

<b>MODULATION TYPE</b>	BPSK	<b>TRANSFER RATE</b>	6Mbps
<b>INPUT POWER (SYSTEM)</b>	120Vac, 60 Hz	<b>ENVIRONMENTAL CONDITIONS</b>	26deg.C, 67%RH, 991hPa
<b>TESTED BY</b>	Long Chen		

CHANNEL	CHANNEL FREQUENCY (MHz)	PEAK POWER EXCURSION (dB)	PEAK to AVERAGE EXCURSION LIMIT (dB)	PASS/FAIL
1	5180	8.62	13	PASS
2	5200	8.20	13	PASS
4	5240	8.87	13	PASS

##### CH 1

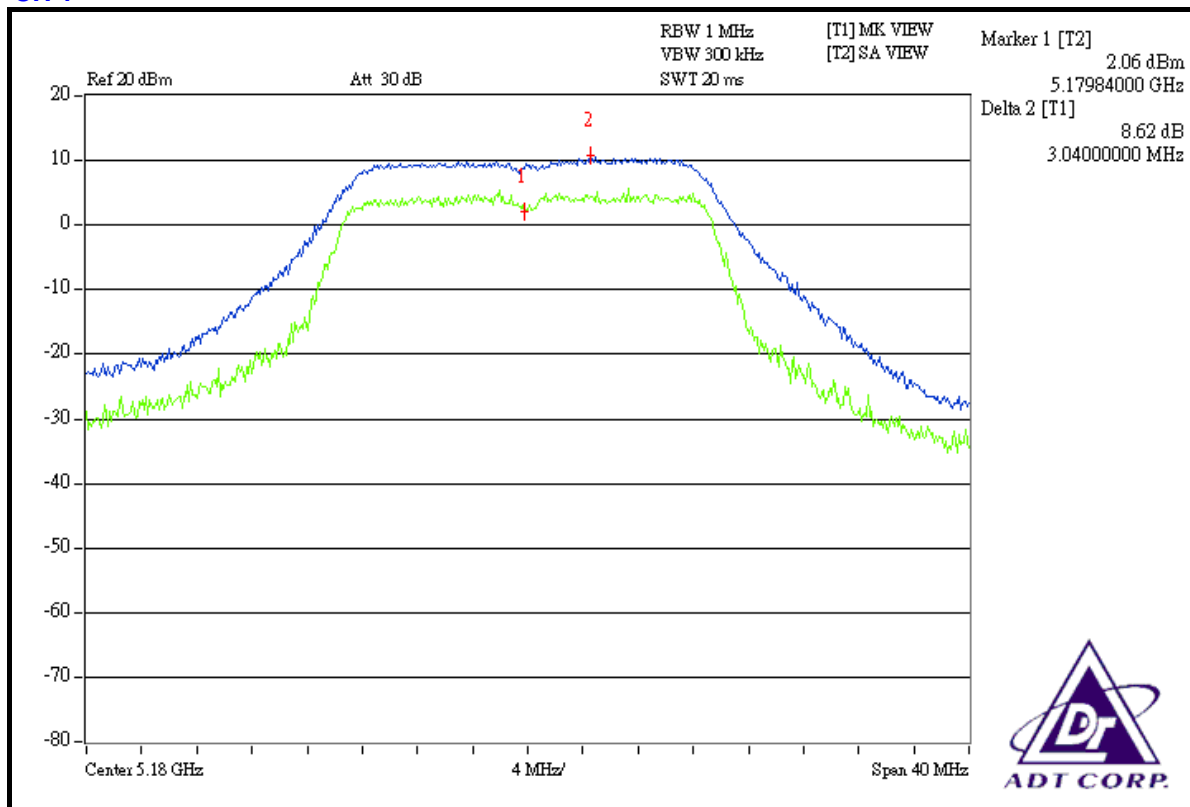



### CH 2

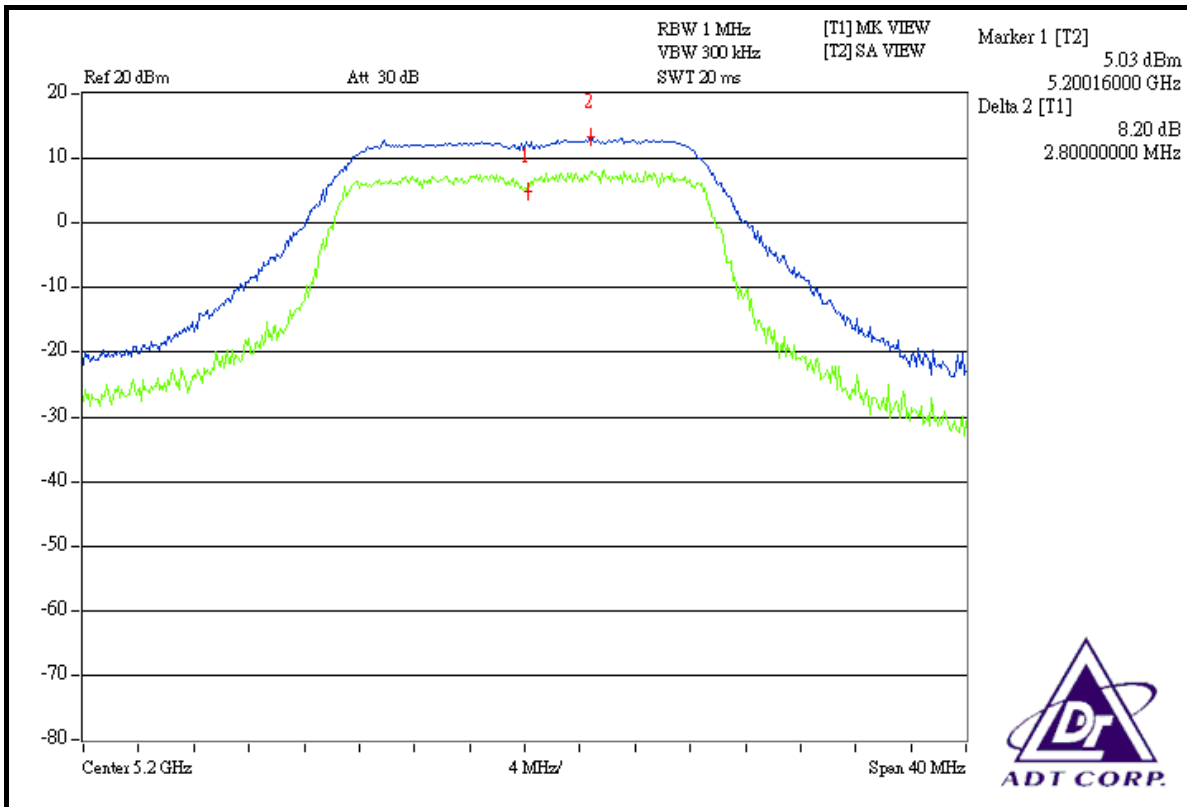

### CH 4

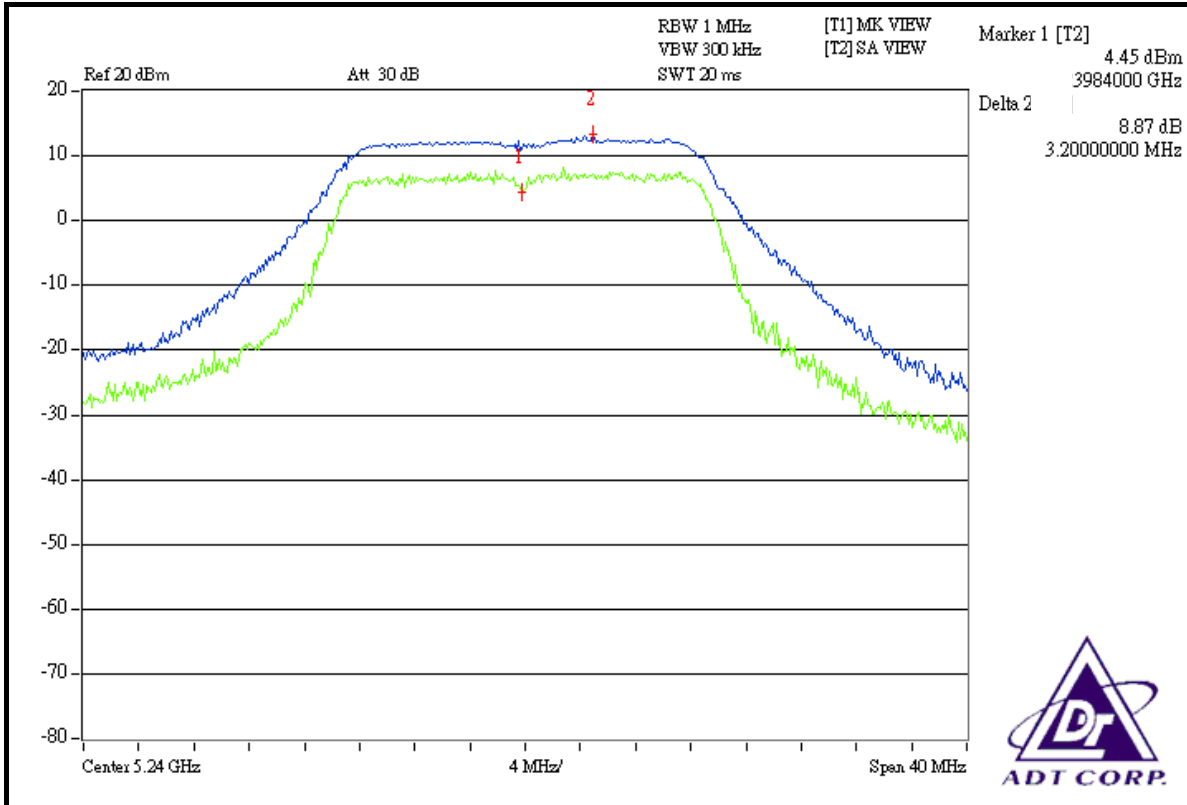



## 4.5 PEAK POWER SPECTRAL DENSITY MEASUREMENT

### 4.5.1 LIMITS OF PEAK POWER SPECTRAL DENSITY MEASUREMENT

Frequency Band	Limit
5.15 ~ 5.25GHz	4dBm
5.25 ~ 5.35GHz	11dBm
5.725 ~ 5.825GHz	17dBm

### 4.5.2 TEST INSTRUMENTS

Description & Manufacturer	Model No.	Serial No.	Calibrated Until
SPECTRUM ANALYZER	FSP40	100040	Jun. 28, 2008

**NOTE:** The calibration interval of the above test instruments is 12 months and the calibrations are traceable to NML/ROC and NIST/USA.

#### 4.5.3 TEST PROCEDURES

1. The transmitter output was connected to the spectrum analyzer.
2. Set RBW=1MHz, VBW=3MHz. The PPSD is the highest level found across the emission in any 1MHz band.

#### 4.5.4 DEVIATION FROM TEST STANDARD

No deviation

#### 4.5.5 TEST SETUP

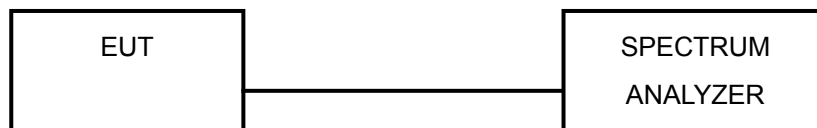

#### 4.5.6 EUT OPERATING CONDITIONS

Same as 5.3.6



## 4.5.7 TEST RESULTS

### 802.11a OFDM modulation

<b>MODULATION TYPE</b>	BPSK	<b>TRANSFER RATE</b>	6Mbps
<b>INPUT POWER (SYSTEM)</b>	120Vac, 60 Hz	<b>ENVIRONMENTAL CONDITIONS</b>	26deg.C, 67%RH, 991hPa
<b>TESTED BY</b>	Long Chen		

CHANNEL	CHANNEL FREQUENCY (MHz)	RF POWER LEVEL IN 1MHz BW (dBm)	MAXIMUM LIMIT (dBm)	PASS/FAIL
1	5180	-0.68	4	PASS
2	5200	1.92	4	PASS
4	5240	1.95	4	PASS

### CH 1

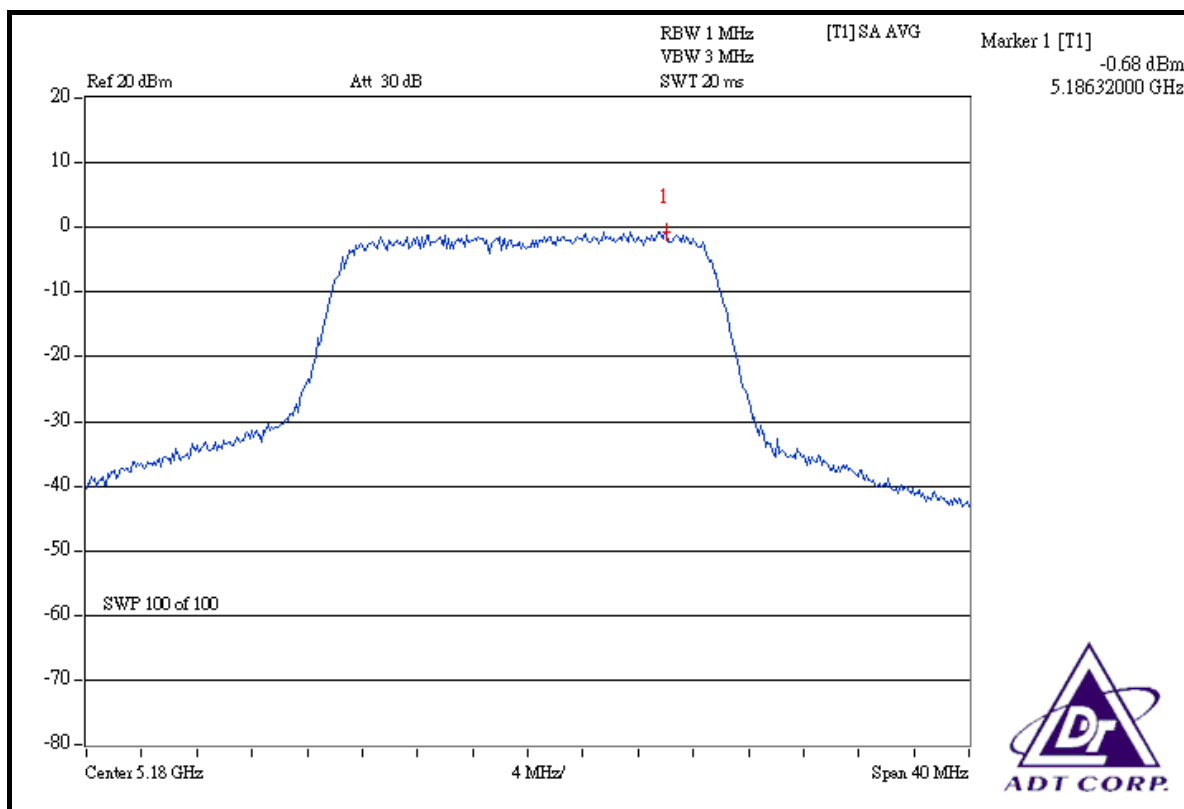





## CH 2

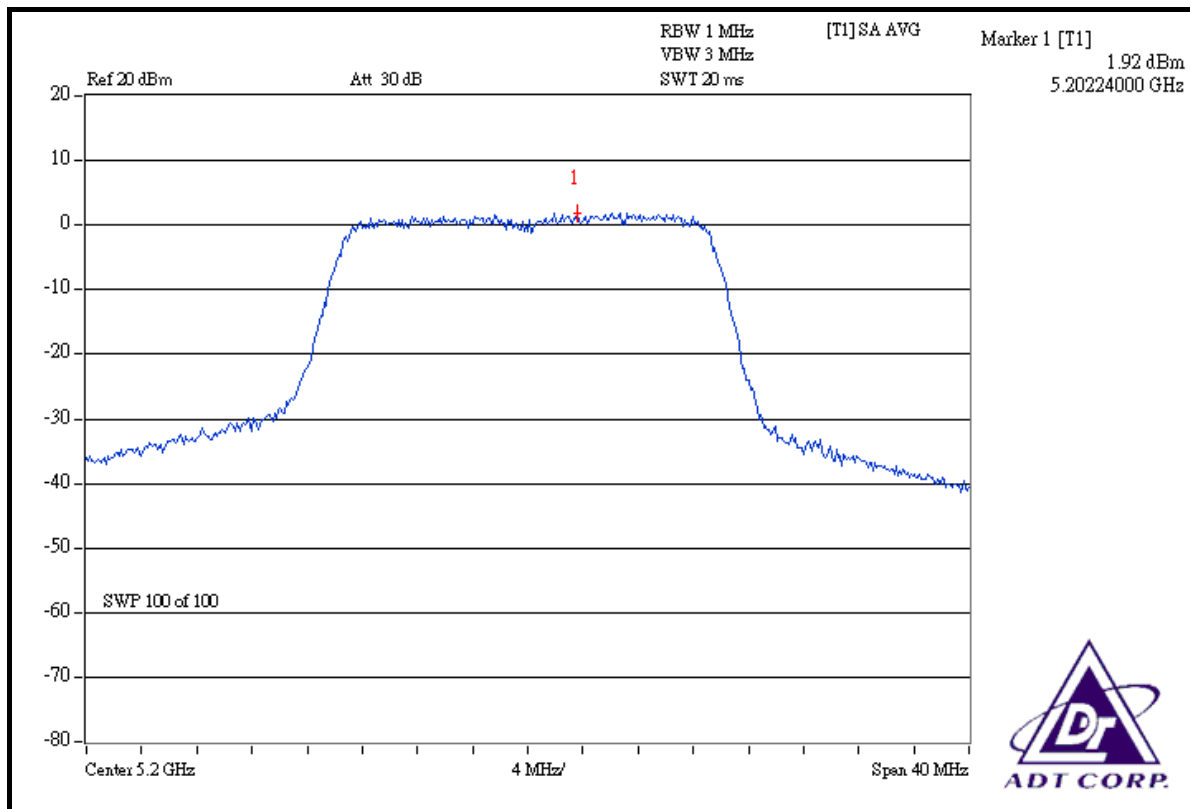

## CH 4

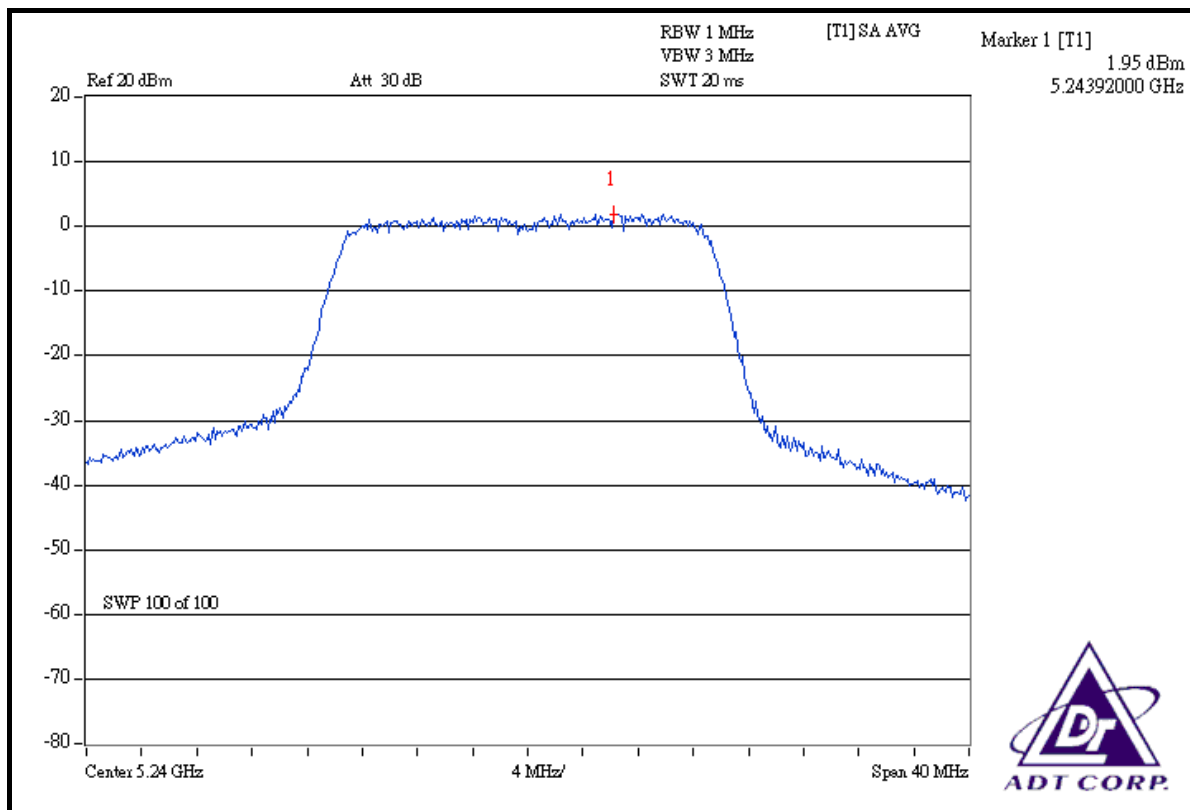



## 4.6 FREQUENCY STABILITY

### 4.6.1 LIMITS OF FREQUENCY STABILITY MEASUREMENT

The frequency tolerance of the carrier signal shall be maintained within +/- 0.02% of the operating frequency over a temperature variation of -30 degrees to 50 degrees C at normal supply voltage, and for a variation in the primary supply voltage from 85% to 115% of the rated supply voltage at a temperature of 20 degrees C.

### 4.6.2 TEST INSTRUMENTS

Description & Manufacturer	Model No.	Serial No.	Calibrated Until
ANRITSU SPECTRUM ANALYZER	MS2667C	M10281	Mar. 07, 2008
WIT STANDARD TEMPERATURE AND HUMIDITY CHAMBER	TH-4S-C	W981030	Jul. 18, 2008

**NOTE:** The calibration interval of the above test instruments is 12 months and the calibrations are traceable to NML/ROC and NIST/USA.

### 4.6.3 TEST PROCEDURE

1. The EUT was placed inside the environmental test chamber and powered by nominal DC voltage.
2. Turn the EUT on and couple its output to a spectrum analyzer.
3. Turn the EUT off and set the chamber to the highest temperature specified.
4. Allow sufficient time (approximately 30 min) for the temperature of the chamber to stabilize, turn the EUT on and measure the operating frequency after 2, 5, and 10 minutes.
5. Repeat step 2 and 3 with the temperature chamber set to the lowest temperature.
6. The test chamber was allowed to stabilize at +20 degree C for a minimum of 30 minutes. The supply voltage was then adjusted on the EUT from 85% to 115% and the frequency record.

#### 4.6.4 DEVIATION FROM TEST STANDARD

No deviation

#### 4.6.5 TEST SETUP

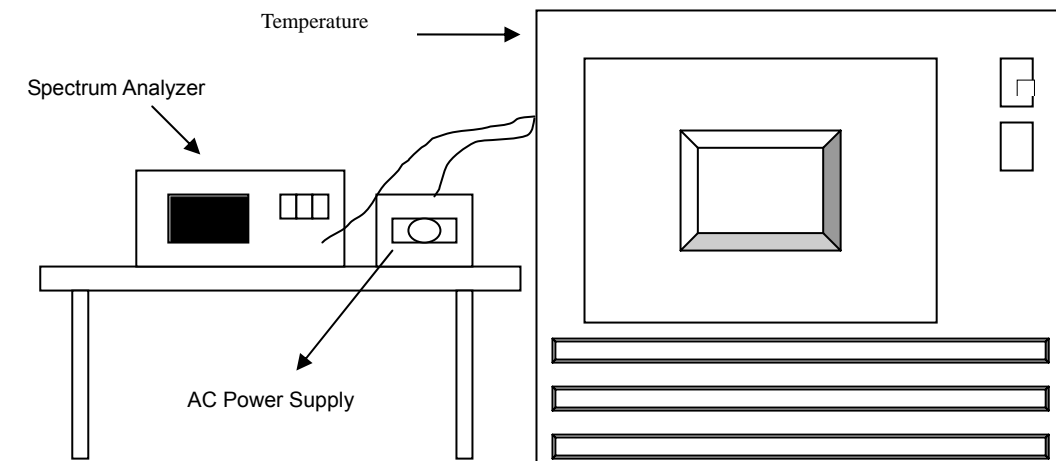

#### 4.6.6 EUT OPERATING CONDITION

Same as Item 4.1.6



#### 4.6.7 TEST RESULTS

Operating frequency: 5200MHz						Limit : ± 0.01%			
Temp. (°C)	Power supply (Vac)	0 minute		2 minute		5 minute		10 minute	
		(MHz)	(%)	(MHz)	(%)	(MHz)	(%)	(MHz)	(%)
50	126.5	5199.9814	-0.0003578	5199.9877	-0.0002366	5199.9819	-0.0003482	5199.9865	-0.0002591
	110.0	5199.9874	-0.0002424	5199.9937	-0.0001212	5199.9854	-0.0002809	5199.9925	-0.0001437
	93.5	5199.9902	-0.0001886	5199.9965	-0.0000674	5199.9895	-0.0002021	5199.9951	-0.0000937
40	126.5	5199.9925	-0.0001443	5199.9988	-0.0000232	5199.9900	-0.0001925	5199.9947	-0.0001014
	110.0	5199.9987	-0.0000251	5200.0050	0.0000961	5199.9974	-0.0000502	5200.0039	0.0000756
	93.5	5200.0003	0.0000057	5200.0066	0.0001268	5199.9988	-0.0000232	5200.0040	0.0000775
30	126.5	5200.0048	0.0000926	5200.0111	0.0002138	5200.0030	0.0000575	5200.0083	0.0001592
	110.0	5200.0085	0.0001644	5200.0148	0.0002856	5200.0063	0.0001207	5200.0117	0.0002258
	93.5	5200.0065	0.0001249	5200.0128	0.0002461	5200.0098	0.0001880	5200.0152	0.0002924
20	126.5	5200.0160	0.0003080	5200.0223	0.0004292	5200.0133	0.0002553	5200.0187	0.0003591
	110.0	5200.0198	0.0003799	5200.0261	0.0005010	5200.0168	0.0003226	5200.0221	0.0004257
	93.5	5200.0235	0.0004517	5200.0298	0.0005728	5200.0203	0.0003899	5200.0256	0.0004924
10	126.5	5200.0272	0.0005235	5200.0335	0.0006446	5200.0238	0.0004573	5200.0291	0.0005590
	110.0	5200.0310	0.0005953	5200.0373	0.0007164	5200.0273	0.0005246	5200.0325	0.0006257
	93.5	5200.0347	0.0006671	5200.0410	0.0007883	5200.0308	0.0005919	5200.0360	0.0006923
0	126.5	5200.0384	0.0007389	5200.0447	0.0008601	5200.0343	0.0006592	5200.0395	0.0007590
	110.0	5200.0422	0.0008107	5200.0485	0.0009319	5200.0378	0.0007265	5200.0429	0.0008256
	93.5	5200.0459	0.0008825	5200.0522	0.0010037	5200.0413	0.0007938	5200.0464	0.0008923
-10	126.5	5200.0496	0.0009544	5200.0559	0.0010755	5200.0448	0.0008611	5200.0499	0.0009589
	110.0	5200.0534	0.0010262	5200.0597	0.0011473	5200.0483	0.0009284	5200.0533	0.0010256
	93.5	5200.0571	0.0010980	5200.0634	0.0012191	5200.0518	0.0009957	5200.0568	0.0010922
-20	126.5	5200.0608	0.0011698	5200.0671	0.0012909	5200.0553	0.0010630	5200.0603	0.0011589
	110.0	5200.0646	0.0012416	5200.0709	0.0013628	5200.0588	0.0011303	5200.0637	0.0012255
	93.5	5200.0683	0.0013134	5200.0746	0.0014346	5200.0623	0.0011976	5200.0672	0.0012922
-30	126.5	5200.0720	0.0013852	5200.0783	0.0015064	5200.0658	0.0012649	5200.0707	0.0013588
	110.0	5200.0758	0.0014570	5200.0821	0.0015782	5200.0693	0.0013323	5200.0741	0.0014255
	93.5	5200.0795	0.0015289	5200.0858	0.0016500	5200.0728	0.0013996	5200.0776	0.0014921



## 4.7 BAND EDGES MEASUREMENT

### 4.7.1 TEST INSTRUMENTS

Description & Manufacturer	Model No.	Serial No.	Calibrated Until
SPECTRUM ANALYZER	FSP40	100040	Jun. 28, 2008

**NOTE:** The calibration interval of the above test instruments is 12 months and the calibrations are traceable to NML/ROC and NIST/USA.

### 4.7.2 TEST PROCEDURE

The transmitter output was connected to the spectrum analyzer via a low loss cable. Set both RBW and VBW of spectrum analyzer to 1MHz with suitable frequency span including 100 MHz bandwidth from band edge. The band edges was measured and recorded.

### 4.7.3 EUT OPERATING CONDITION

The software provided by client to enable the EUT under transmission condition continuously at specific channel frequencies individually.

### 4.7.4 TEST RESULTS

For signals in the restricted bands above and below the 5.15 to 5.35GHz allocated band a measurement was made of the amplitude of the spurious emissions with respect to the intentional signals. The relative amplitude, in dBc, was applied to the average and peak filed strength of the intentional signal made on the OATS to calculate the field strength of the unintentional signals.

The spectrum plots (Peak RBW=1MHz, VBW=3MHz; Average RBW=1MHz, VBW=10Hz) are attached on the following pages.



#### Channel 1 (5180MHz)

The band edge emission plot on the next page shows 37.80dBc between carrier maximum power and local maximum emission in restrict band. The emission of carrier strength list in the test result of channel 1 is 109.33dBuV/m (Peak), so the maximum field strength in restrict band is  $109.33-37.80=71.53$ dBuV/m which is under 74dBuV/m limit.

The band edge emission plot on the next page shows 47.10dBc between carrier maximum power and local maximum emission in restrict band. The emission of carrier strength list in the test result of channel 1 is 97.60dBuV/m (Average), so the maximum field strength in restrict band is  $97.60-47.10=50.50$ dBuV/m which is under 54dBuV/m limit.

#### Channel 4 (5240MHz)

The band edge emission plot on the next second page shows 53.85dBc between carrier maximum power and local maximum emission in restrict band. The emission of carrier strength list in the test result of channel 4 is 112.49dBuV/m (Peak), so the maximum field strength in restrict band is  $112.49-53.85=58.64$ dBuV/m which is under 74dBuV/m limit.

The band edge emission plot on the next third page shows 55.33dBc between carrier maximum power and local maximum emission in restrict band. The emission of carrier strength list in the test result of channel 4 is 101.27dBuV/m (Average), so the maximum field strength in restrict band is  $101.27-55.33=45.94$ dBuV/m which is under 54dBuV/m limit.

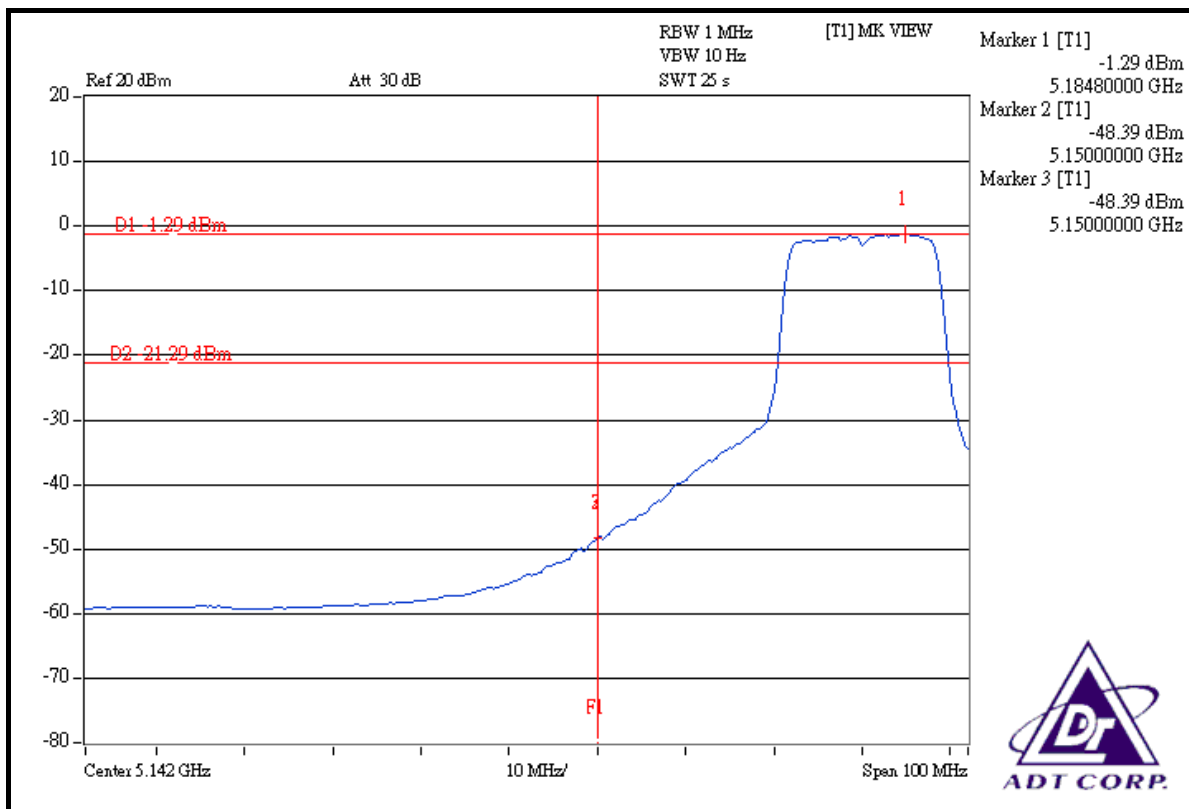
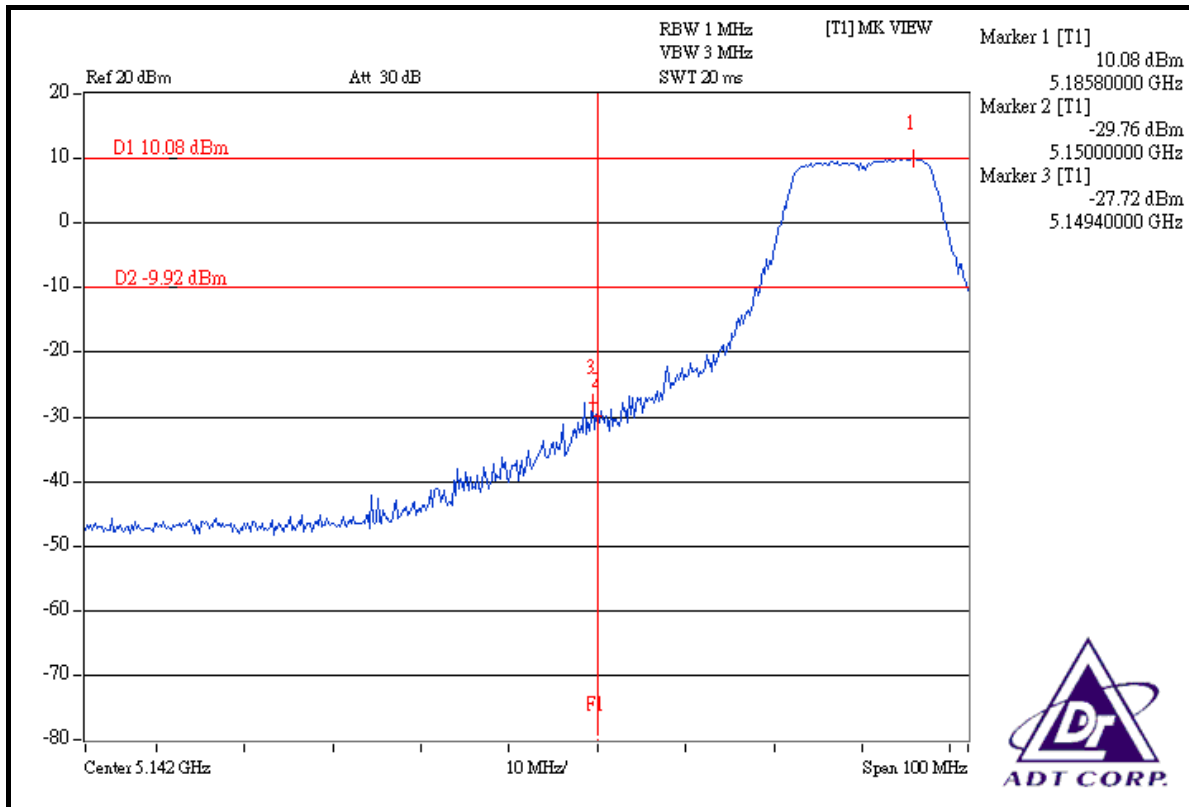

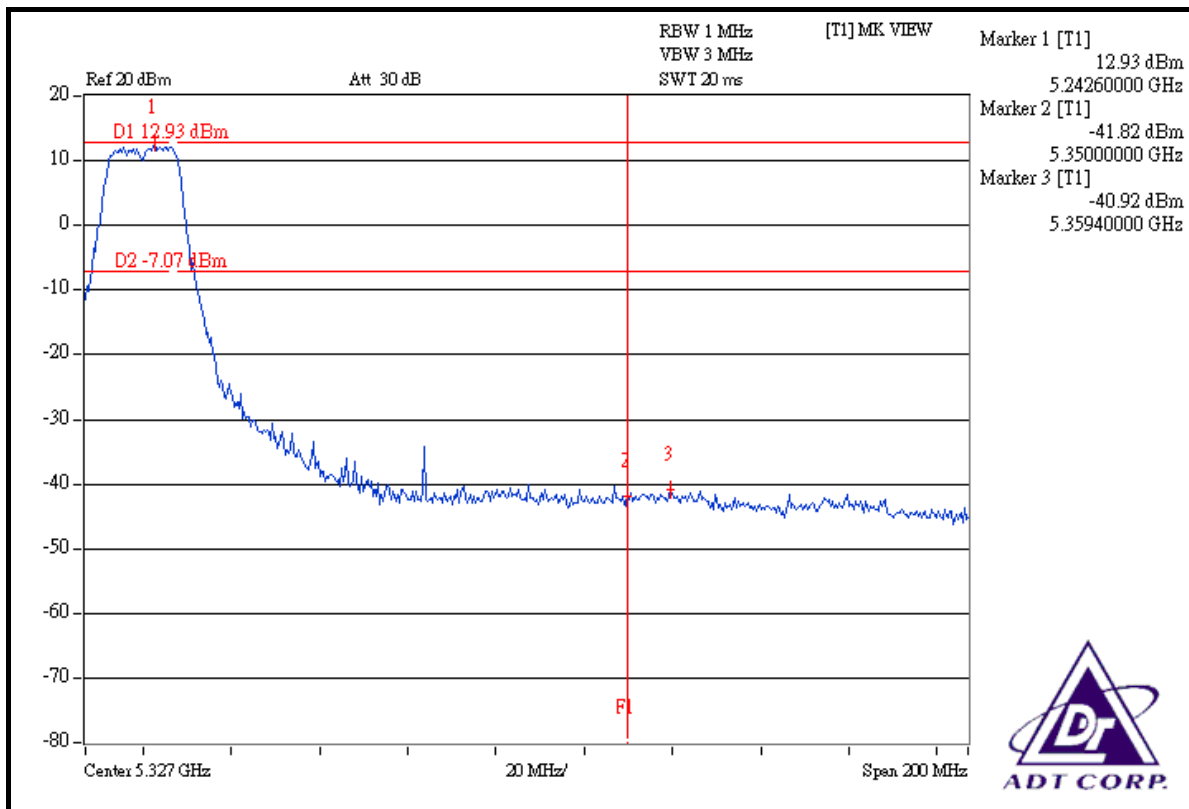
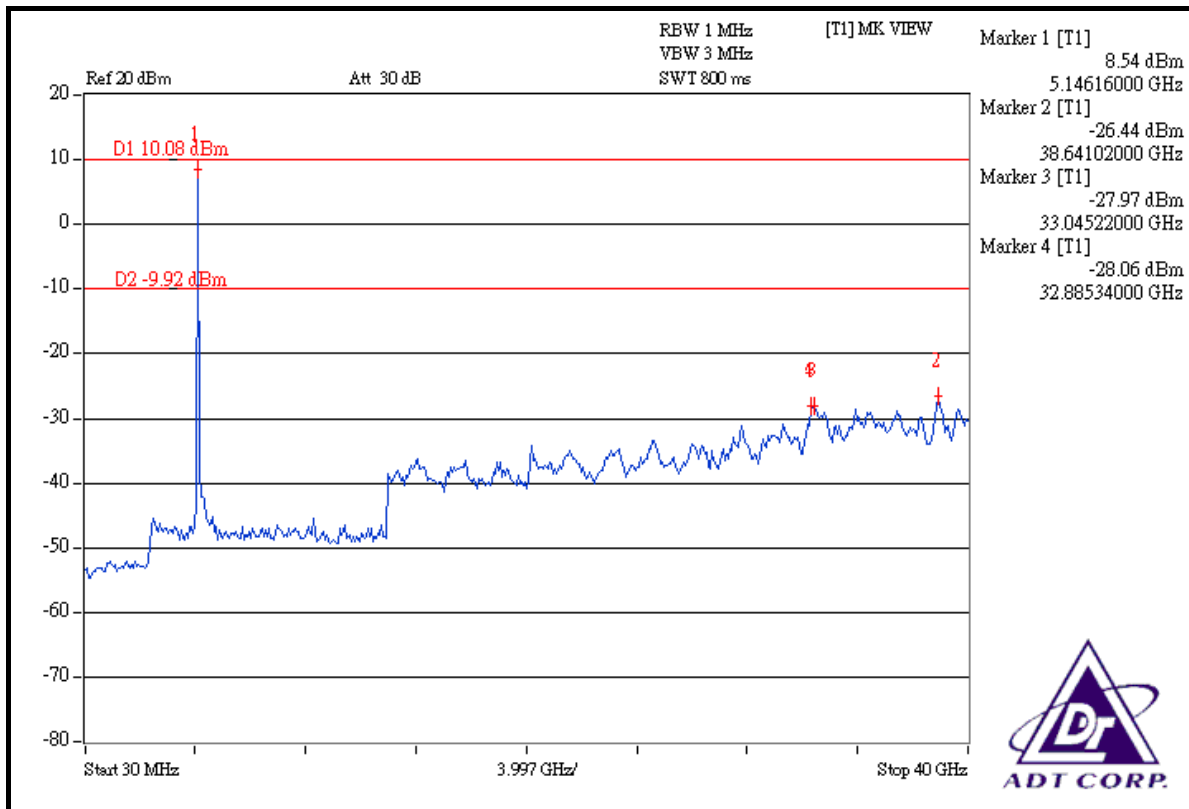



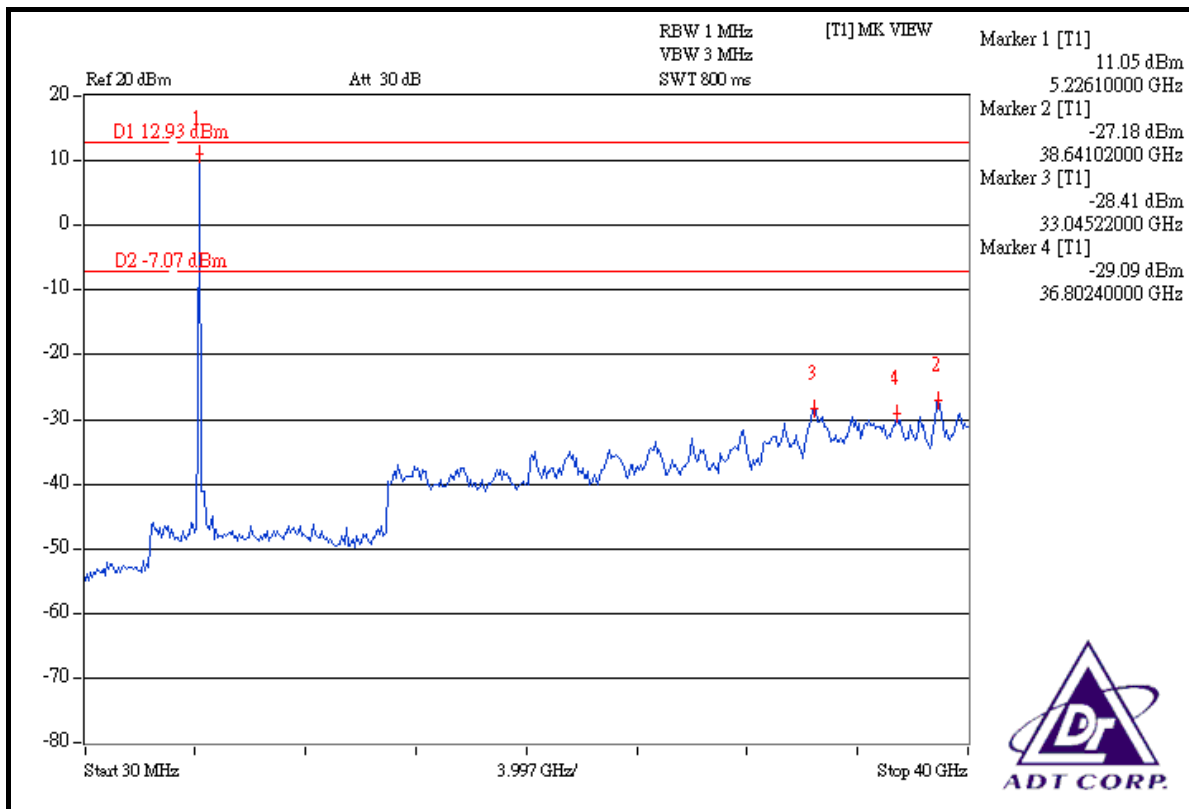
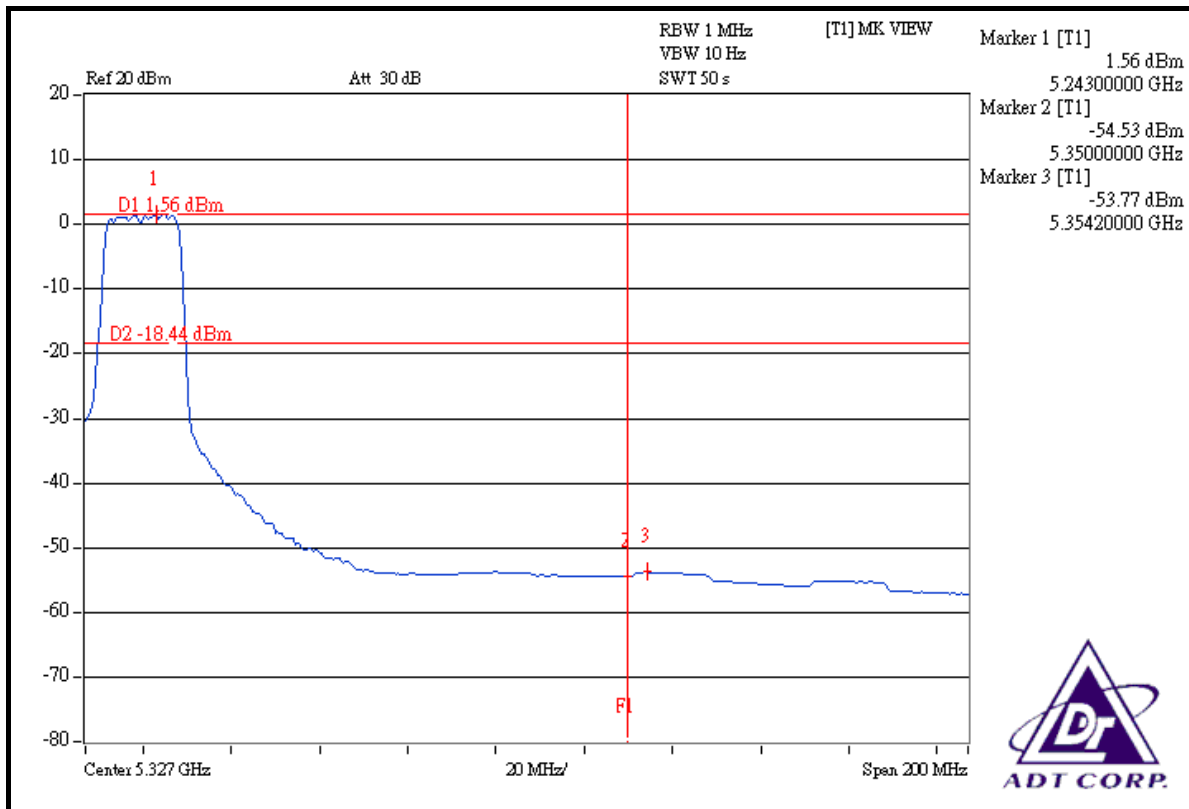



## **4.8 ANTENNA REQUIREMENT**

### **4.8.1 STANDARD APPLICABLE**

For intentional device, according to FCC 47 CFR Section 15.203, an intentional radiator shall be designed to ensure that no antenna other than that furnished by the responsible party shall be used with the device.

And according to FCC 47 CFR Section 15.407(a), if transmitting antennas of directional gain greater than 6dBi are used, the power shall be reduced by the amount in dB that the directional gain of the antenna exceeds 6dBi.

### **4.8.2 ANTENNA CONNECTED CONSTRUCTION**

The antenna used in this product is Dipole antenna without connector. The maximum Gain of the antenna is 1.65dBi.



## **5. PHOTOGRAPHS OF THE TEST CONFIGURATION**

Please refer to the attached file (Test Setup Photo).



## 6. INFORMATION ON THE TESTING LABORATORIES

We, ADT Corp., were founded in 1988 to provide our best service in EMC, Radio, Telecom and Safety consultation. Our laboratories are accredited and approved by the following approval agencies according to ISO/IEC 17025.

<b>USA</b>	FCC, UL, A2LA
<b>Germany</b>	TUV Rheinland
<b>Japan</b>	VCCI
<b>Norway</b>	NEMKO
<b>Canada</b>	INDUSTRY CANADA , CSA
<b>R.O.C.</b>	TFA, BSMI, NCC
<b>Netherlands</b>	Telefication
<b>Singapore</b>	PSB , GOST-ASIA(MOU)
<b>Russia</b>	CERTIS(MOU)

Copies of accreditation certificates of our laboratories obtained from approval agencies can be downloaded from our web site:

[www.adt.com.tw/index.5/phtml](http://www.adt.com.tw/index.5/phtml). If you have any comments, please feel free to contact us at the following:

**Linko EMC/RF Lab:**

Tel: 886-2-26052180

Fax: 886-2-26051924

**Hsin Chu EMC/RF Lab:**

Tel: 886-3-5935343

Fax: 886-3-5935342

**Hwa Ya EMC/RF/Safety Telecom Lab:**

Tel: 886-3-3183232

Fax: 886-3-3185050

**Web Site:** [www.adt.com.tw](http://www.adt.com.tw)

The address and road map of all our labs can be found in our web site also.



## **7. APPENDIX A - MODIFICATIONS RECORDERS FOR ENGINEERING CHANGES TO THE EUT BY THE LAB**

No any modifications are made to the EUT by the lab during the test.