

TEST REPORT

EUT Description	Convertible PC
Brand Name	HP
Model Name	HSN-I61C
FCC/IC ID	FCC ID: B94HNI61CKL4; IC ID: 21374-FM350GL
Date of Test Start/End	2024-02-14 / 2024-02-21
Features	WWAN (UMTS, LTE, NR) (see section 5)

Applicant	HP
Address	1501 Page Mill Road, Palo Alto CA 94304 USA
Contact Person	Sam Lin
Telephone/Fax/ Email	(TEL) +886 2 37896331/sam.lin2@hp.com

Reference Standards	FCC CFR Title 47 Part 2, 22, 24, 27, 90, 96 RSS-Gen issue 5 A1, RSS 130 issue 2, RSS 132 issue 3, RSS 133 issue 6 A1, RSS 140 issue 1, RSS 139 issue 4, RSS-192 issue 5, RSS-195 issue 2, RSS 199 issue 4, RSS 197 issue 1 (see section 0)
---------------------	---

Test Report identification	231128-05.TR06
Revision Control	Rev. 00 This test report revision replaces any previous test report revision (see section 8)

The test results relate only to the samples tested.
 Reference to accreditation shall be used only by full reproduction of test report.

Issued by _____ Reviewed by _____

Robin LUCIANI
 (RFR Test Engineer Lead)

Zayd OUACHICHA
 (Technical Manager)

Table of Contents

1. Standards, reference documents and applicable test methods	3
2. General conditions, competences and guarantees	3
3. Environmental Conditions	4
4. Test samples	5
5. EUT Features	5
6. Remarks and comments	8
7. Test Verdicts summary	9
8. Document Revision History	11
Annex A. Test & System Description	12
A.1 Measurement System.....	12
A.2 Test Equipment List.....	15
A.2.1 RADIATED SETUP	15
A.3 Measurement Uncertainty Evaluation.....	16
Annex B. Test Results	17
B.1 Radiated spurious emission.....	17
B.1.1 STANDARD REFERENCES	17
B.1.2 TEST PROCEDURE	20
B.1.3 TEST RESULTS.....	21
B.1.3.1 WCDMA	21
B.1.3.1 LTE.....	22
B.1.3.2 5G NR	26
B.1.3.3 LTE ULCA-INTRA	29
B.1.3.4 LTE ULCA-INTER	31
B.1.3.5 EN-DC.....	35
B.2 Declared ERP / EIRP	37
Annex C. Photographs	38
C.1 Radiated Test Setup.....	38
C.2 Test Sample	39

1. Standards, reference documents and applicable test methods

FCC	<ol style="list-style-type: none"> 1. FCC Title 47 CFR part 2 - Subpart J - Equipment Authorization Procedures. 2021-10-01 Edition 2. FCC Title 47 CFR part 22 - Subpart H - Cellular Radiotelephone Service. 2021-10-01 Edition 3. FCC Title 47 CFR part 24 – Subpart E - Broadband PCS. 2021-10-01 Edition 4. FCC Title 47 CFR part 27 – Subpart C - Technical Standards. 2021-10-01 Edition 5. FCC Title 47 CFR part 27 – Subpart L - 1695-1710, 1710-1755 MHz, 1755-1780 MHz, 2110-2155 MHz, 2155-2180 MHz, 2180-2200 MHz Bands. 2021-10-01 Edition 6. FCC Title 47 CFR Part 90 - Subpart R - Regulations governing the licensing and use of frequencies in the 763-775 and 793-805 MHz bands. 2021-10-01 Edition 7. FCC Title 47 CFR Part 90 - Subpart S - Regulations governing licensing and use of frequencies in the 806-824, 851-869, 896-901, and 935-940 MHz bands. 2021-10-01 Edition 8. FCC Title 47 CFR Part 96 - Subpart E - Technical rules. 2021-10-01 Edition 9. FCC OET KDB 971168 D01 v03r01 Measurement guidance for certification of licensed digital transmitters. 10. FCC OET KDB 842590 D01 v01r02 Upper Microwave Flexible Use Service. 11. C63.26-2015 - IEEE/ANSI Standard for Compliance Testing of Transmitters Used in Licensed Radio Services
ISED	<ol style="list-style-type: none"> 1. ISED RSS-Gen issue 5 A1 - General Requirements for Compliance of Radio Apparatus. 2. ISED RSS-130 issue 2 - Equipment Operating in the Frequency Bands 617-652 MHz, 663-698 MHz, 698-756 MHz and 777-787 MHz 3. ISED RSS 132 issue 3 - Cellular Telephone Systems Operating in the Bands 824-849 MHz and 869-894 MHz 4. ISED RSS 133 issue 6 A1 - 2 GHz Personal Communications Services. 5. ISED SRSP-510 — Technical Requirements for Personal Communications Services (PCS) in the Bands 1850-1915 MHz and 1930-1995 MHz 6. ISED RSS 139 issue 4 - Advanced Wireless Services Equipment Operating in the Bands 1710-1780 MHz and 2110-2200 MHz 7. ISED RSS-140 issue 1 - Equipment Operating in the Public Safety Broadband Frequency Bands 758-768 MHz and 788-798 MHz 8. ISED RSS-192 issue 5 - Flexible Use Broadband Equipment Operating in the Band 3450-3900 MHz 9. ISED RSS-195 issue 2 - Wireless Communication Service (WCS) Equipment Operating in the Bands 2305-2320 MHz and 2345-2360 MHz 10. ISED RSS-199 issue 4 - Broadband Radio Services (BRS) Equipment Operating in the Bands 2500-2690 MHz 11. ISED RSS-197 issue 1 - Wireless Broadband Access Equipment Operating in the Band 3650–3700 MHz 12. FCC OET KDB 971168 D01 v03r01 Measurement guidance for certification of licensed digital transmitters. 13. FCC OET KDB 842590 D01 v01r02 Upper Microwave Flexible Use Service. 14. C63.26-2015 - IEEE/ANSI Standard for Compliance Testing of Transmitters Used in Licensed Radio Services 15. C63.4-2014 – American National Standard for Methods of measurement of Radio-Noise Emissions from Low-Voltage Electrical and Electronic Equipment in the Range of 9kHz to 40GHz.

2. General conditions, competences and guarantees

- ✓ Tests performed under FCC standards identified in section 1 are covered by A2LA accreditation.
- ✓ Tests performed under ISED standards identified in section 1 are covered by Cofrac accreditation.
- ✓ Intel Corporation SAS Wireless RF Lab (Intel WRF Lab) is an ISO/IEC 17025:2017 laboratory accredited by the American Association for Laboratory Accreditation (A2LA) with the certificate number 3478.01.
- ✓ Intel Corporation SAS Wireless RF Lab (Intel WRF Lab) is an Accredited Test Firm recognized by the FCC, with Designation Number FR0011.
- ✓ Intel Corporation SAS Wireless RF Lab (Intel WRF Lab) is an ISO/IEC 17025:2017 testing laboratory accredited by the French Committee for Accreditation (Cofrac) with the certificate number 1-6736.
- ✓ Intel Corporation SAS Wireless RF Lab (Intel WRF Lab) is a Registered Test Site listed by ISED, with ISED company number 1000Y and CAB identifier FR0005.
- ✓ Intel WRF Lab only provides testing services and is committed to providing reliable, unbiased test results and interpretations.
- ✓ Intel WRF Lab is liable to the client for the maintenance of the confidentiality of all information related to the item under test and the results of the test.
- ✓ Intel WRF Lab has developed calibration and proficiency programs for its measurement equipment to ensure correlated and reliable results to its customers.
- ✓ This report is only referred to the item that has undergone the test.
- ✓ This report does not imply an approval of the product by the Certification Bodies or competent Authorities.

3. Environmental Conditions

- ✓ At the site where the measurements were performed the following limits were not exceeded during the tests:

Temperature	24.7°C ± 3.3°C
Humidity	34.7% ± 9.6%

4. Test samples

Sample	Control #	Description	Model	Serial #	Date of receipt	Note
#01	231128-06.S03	Convertible PC	HSN-I61C	0003770D9R	06/12/2023	Vendor 1
#02	231128-05.S09	Convertible PC	HSN-I61C	0003770DBJ	06/12/2023	Vendor 2

5. EUT Features

The herein information is provided by the customer.

Intel WRF Lab declines any responsibility for the accuracy of the stated customer provided information, especially if it has any impact on the correctness of test results presented in this report.

Brand Name	HP							
Model Name	HSN-I61C							
Prototype / Production	Production							
Supported Radios	Mode	Bands	Supported Tx Mode					
			WCDMA	HSDPA	HSUPA	DC-HSDPA		
	WCDMA / HSPA+	FDD II (1850.0 – 1910.0 MHz)	✓	✓	✓	✓	✓	
		FDD IV (1710.0 – 1755.0 MHz)	✓	✓	✓	✓	✓	
		FDD V (824.0 – 849.0 MHz)	✓	✓	✓	✓	✓	
	Mode	Bands	Supported Channel Bandwidth (MHz)					
			1.4	3	5	10	15	20
	LTE FDD	Band 2 (1850.0 – 1910.0 MHz)	✓	✓	✓	✓	✓	✓
		Band 4 (1710.0 – 1755.0 MHz)	✓	✓	✓	✓	✓	✓
		Band 5 (824.0 – 849.0 MHz)	✓	✓	✓	✓		
		Band 7 (2500.0 – 2570.0 MHz)			✓	✓	✓	✓
		Band 12 (699.0 – 716.0 MHz)	✓	✓	✓	✓		
		Band 13 (777.0 – 787.0 MHz)			✓	✓		
		Band 14 (788.0 – 798.0 MHz)						
		Band 17 (704.0 – 716.0 MHz)			✓	✓		
		Band 25 (1850.0 – 1915.0 MHz)			✓	✓	✓	✓
		Band 26 (814.0 – 849.0 MHz)	✓	✓	✓	✓	✓	
	LTE TDD	Band 30 (2305.0 – 2315.0 MHz)			✓	✓		
		Band 66 (1710.0 – 1780.0 MHz)	✓	✓	✓	✓	✓	✓
		Band 71 (663.0 – 698.0 MHz)			✓	✓	✓	✓
Band 38 (2570.0 – 2620.0 MHz)				✓	✓	✓	✓	
	Band 41 (2496.0 – 2690.0 MHz)			✓	✓	✓	✓	
	Band 48 (3550.0 – 3700.0MHz)			✓	✓	✓	✓	

Supported Radios	Mode	Bands	Modulation	SCS (KHz)	Bandwidth												
					5	10	15	20	25	30	40	50	60	70	80	90	100
5G NR	N2 FDD (1850.0 – 1910.0 MHz)	PI/2 BPSK QPSK 16QAM 64QAM 256QAM	15 30	✓	✓	✓	✓										
	N5 FDD (824.0 – 849.0 MHz)	PI/2 BPSK QPSK 16QAM 64QAM 256QAM	15 30	✓	✓	✓	✓										
	N7 FDD (2500.0 – 2570.0 MHz)	PI/2 BPSK QPSK 16QAM 64QAM 256QAM	15 30	✓	✓	✓	✓										
	N25 FDD (1850.0 – 1915 MHz)	PI/2 BPSK QPSK 16QAM 64QAM 256QAM	15 30	✓	✓	✓	✓										
	N30 FDD (2305.0 – 2315.0 MHz)	PI/2 BPSK QPSK 16QAM 64QAM 256QAM	15 30	✓	✓												
	N38 TDD (2570.0 – 2620.0 MHz)	PI/2 BPSK QPSK 16QAM 64QAM 256QAM	15 30	✓	✓	✓	✓										
	N41 TDD (2496.0 – 2690.0 MHz)	PI/2 BPSK QPSK 16QAM 64QAM 256QAM	15 30		✓	✓	✓				✓	✓	✓		✓	✓	✓
	N48 TDD (3550.0 – 3700.0 MHz)	PI/2 BPSK QPSK 16QAM 64QAM 256QAM	15 30	✓	✓	✓	✓				✓	✓					
	N66 FDD (1710.0 – 1780.0 MHz)	PI/2 BPSK QPSK 16QAM 64QAM 256QAM	15 30	✓	✓	✓	✓				✓	✓					
	N71 FDD (663.0 – 698.0 MHz)	PI/2 BPSK QPSK 16QAM 64QAM 256QAM	15 30	✓	✓	✓	✓										
	N77 TDD (3450.0-3550.0 MHz) (3700.0 – 3980.0 MHz)	PI/2 BPSK QPSK 16QAM 64QAM 256QAM	15 30		✓	✓	✓				✓	✓	✓		✓	✓	✓
	N78 TDD (3700.0 – 3800.0 MHz)	PI/2 BPSK QPSK 16QAM 64QAM 256QAM	15 30		✓	✓	✓				✓	✓	✓		✓	✓	✓

Supported Radios	UL carrier aggregation LTE (Inter-Band)			
	Supported combinations			
	2A-5A	2A-12A	2A-13A	2A-14A
	2A-48A	4A-5A	4A-12A	4A-13A
	5A-7A	5A-30A	5A-48A	5A-66A
	12A-30A	12A-66A	13A-48A	13A-66A
	14A-30A	14A-66A	25A-26A	48A-66A
	UL carrier aggregation LTE (Intra-band)			
	Supported combinations			
	5B	7C	38C	41C
48C	66B	66C		
EN-DC				
Supported combinations				
NR 5G Band		Associated LTE Bands		
N2A		LTE Bands: 5, 12, 13, 14		
N5A		LTE Bands: 2, 7, 30, 66, 48		
N66A		LTE Bands: 5, 12, 13, 48		
N41A		LTE Bands: 2, 66, 41		
N48A		LTE Bands: 2, 66		
N77A		LTE Bands: 2, 5, 12, 13, 14, 30, 66, 41		
N78A		LTE Bands: 2, 5, 7, 38		
UL carrier aggregation 5G FR1				
UL carrier aggregation 5G FR1				
n2A-n5A				
n5A-n66A				

Antenna Information	Transmitter	Ant 5	Ant 8
	Manufacturer	Vendor 1	Vendor 1
	Antenna type	PIFA antenna	PIFA antenna
	Part number	6036B0346901 (00-3302702850)	6036B0346901 (00-3302702850)
	Antenna peak gain (dBi)	2.93	2.54
	Transmitter	Ant 5	Ant 8
	Manufacturer	Vendor 2	Vendor 2
	Antenna type	PIFA Antenna	PIFA Antenna
	Part number	6036B0345901 (81ELBA15.G02)	6036B0345901 (81ELBA15.G02)
	Antenna peak gain (dBi)	2.05	1.92

contention-based Protocol Declaration "information provided by the applicant"	The declaration includes a description of the methodology used to meet the requirement that each transmitter employs a contention-based protocol and indicates whether the equipment is capable of avoiding co-frequency interference with equipment using all other types of contention-based protocols (restricted or unrestricted contention protocols).
--	---

6. Remarks and comments

1. The DUT has two antenna manufacturers (Vendor 1 and Vendor 2) but the WWAN module and the rated output power remain the same. For each band, tests were performed on the highest peak antenna gain.
2. The tested configurations were selected based on the worst-case spurious emissions per frequency band from modular type approval report (FCC ID : B94HNI61CKL4, IC ID : 21374-FM350GL).
3. In regard of RSS 197 annex C shows a description of the algorithm implementation for both reducing the EIRP the limit allowed and decoding an enabling signal from the base station before the mobile equipment can transmit

7. Test Verdicts summary

The statement of conformity to applicable standards in the table below are based on the measured values, without taking into account the measurement uncertainties.

Band	Band	FCC part	RSS part	Verdict
WCDMA	WCDMA II*	24.238, 2.1053	133-ch 6.5.1	P
	WCDMA IV	27.53 (h), 2.1053	139-ch.5.6	P
	WCDMA V*	22.917(a), 2.1053	132-ch.5.5	P
LTE	LTE 2*	24.238(a), 2.1053	133-ch 6.5.1	P
	LTE4	27.53 (h), 2.1053	139-ch.5.6	NM
	LTE 5*	22.917(a), 2.1053	132-ch.5.5	NM
	LTE 7	27.53 (m)(4), 2.1053	199-ch.5.6	P
	LTE12	27.53 (g), 2.1053	130-ch.4.7	P
	LTE 13	27.53 (c)(f), 2.1053	130-ch.4.7	P
	LTE14	90.543(e)(f), 2.1053	140-ch.4.4	P
	LTE17	27.53 (g), 2.1053	130-ch.4.7	NM
	LTE 25*	24.238(a), 2.1053	133-ch 6.5.1	P
	LTE 26*	90.691, 22.917(a), 2.1053	132-ch.5.5	P
	LTE 30	27.53 (a)(4), 2.1053	195- ch.5.6.2	P
	LTE 38	27.53 (m)(4), 2.1053	199-ch.5.6	NM
	LTE 41	27.53 (m)(4), 2.1053	199-ch.5.6	P
	LTE 48*	96.41(e), 2.1053	192-ch.5.6, 197-ch.5.7	P
	LTE 66	27.53(h), 2.1053	139-ch.5.6	P
	LTE 71	27.53(m)(4), 2.1053	130-ch.4.7	P
LTE ULCA	5B_CA	22.917(a), 2.1053	132-ch.5.5	P
	66B_CA	27.53(h), 2.1053	139-ch.5.6	P
	66C_CA	27.53(h), 2.1053	139-ch.5.6	NM
	7C_CA	27.53 (m)(4), 2.1053	199-ch.5.6	P
	38C_CA	27.53 (m)(4), 2.1053	199-ch.5.6	NM
	41C_CA	27.53 (m)(4), 2.1053	199-ch.5.6	P
	48C_CA	96.41(e), 2.1053	192-ch.5.6, 197-ch.5.7	P
	2A-13A	24.238(a), 27.53 (c)(f), 2.1053	133-ch 6.5.1, 130-ch.4.7	P
	2A-48A	24.238(a), 96.41(e), 2.1053	133-ch 6.5.1, 192-ch.5.6 197-ch.5.7	P
	5A-7A	22.917(a), 27.53 (m)(4), 2.1053	132-ch.5.5, 199-ch.5.6	P
	5A-66A	22.917(a), 27.53(h), 2.1053	132-ch.5.5, 139-ch.5.6	P
	12A-30A	27.53 (g), 27.53 (a)(4), 2.1053	130-ch.4.7, 195- ch.5.6.2	P
	12A-66A	27.53 (g), 27.53(h), 2.1053	130-ch.4.7, 139-ch.5.6	P
	13A-48A	27.53 (c)(f), 96.41(e), 2.1053	130-ch.4.7, 192-ch.5.6 197-ch.5.7	P
	14A-30A	90.543(e)(f), 27.53 (a)(4), 2.1053	140-ch.4.4, 195- ch.5.6.2	P
	14A-66A	90.543(e)(f), 27.53(h), 2.1053	140-ch.4.4, 139-ch.5.6	P
25A-26A	24.238, 90.691, 22.917, 2.1053	133-ch 6.5.1, 132-ch.5.5	P	

Band	Band	FCC part	RSS part	Verdict
5G NR FR1	N2*	24.238(a), 2.1053	133-ch 6.5.1	NM
	N5*	22.917(a), 2.1053	132-ch.5.5	P
	N7	27.53(m)(4), 2.1053	199-ch.5.6	P
	N25*	24.238, 2.1053	133-ch 6.5.1	P
	N30	27.53 (a)(4), 2.1053	195- ch.5.6.2	P
	N38	27.53 (m)(4), 2.1053	199-ch.5.6	NM
	N41 (HPUE)	27.53(m)(4), 2.1053	199-ch.5.6	P
	N48*	96.41(e), 2.1053	192-ch.5.6, 197-ch.5.7	NM
	N66	27.53(h), 2.1053	139-ch.5.6	P
	N77 (HPUE)	27.53(l)(n), 2.1053	NA	P
	N78	27.53(l), 2.1053	NA	NM
5G NR FR1 ULCA	N2A - N5A	24.238(a), 22.917(a), 2.1053	133-ch 6.5.1, 132-ch.5.5,	NM
	N5A - N66A	22.917(a), 27.53(h), 2.1053	132-ch.5.5, 139-ch.5.6	NM
EN-DC	5A - N2A	22.917(a), 24.238(a), 2.1053	132-ch.5.5, 133-ch 6.5.1	P
	12A - N2A	27.53 (g), 24.238(a), 2.1053	130-ch.4.7, 133-ch 6.5.1	NM
	13A - N2A	27.53 (c)(f), 24.238(a), 2.1053	130-ch.4.7, 133-ch 6.5.1	NM
	14A - N2A	90.543(e)(f), 24.238(a) 2.1053	140-ch.4.4, 133-ch 6.5.1	NM
	2A - N5A	24.238(a), 22.917(a), 2.1053	133-ch 6.5.1, 132-ch.5.5	P
	7A - N5A	27.53 (m)(4), 22.917(a), 2.1053	199-ch.5.6 ,132-ch.5.5	NM
	30A - N5A	27.53 (a)(4), 22.917(a), 2.1053	195- ch.5.6.2, 132-ch.5.5	NM
	66A - N5A	27.53(h), 22.917(a), 2.1053	139-ch.5.6, 132-ch.5.5	NM
	48A - N5A	96.41(e), 22.917(a), 2.1053	192-ch.5.6, 197-ch.5.7, 132-ch.5.5	NM
	5A - N66A	22.917(a), 27.53(h), 2.1053	132-ch.5.5, 139-ch.5.6	NM
	12A - N66A	27.53 (g), 27.53(h), 2.1053	130-ch.4.7 ,139-ch.5.6	NM
	13A - N66A	27.53 (c)(f), 27.53(h), 2.1053	130-ch.4.7, 139-ch.5.6	NM
	48A - N66A	96.41(e), 27.53(h), 2.1053	192-ch.5.6 197-ch.5.7, 139-ch.5.6	P
	2A - N41A (HPUE)	24.238(a)27.53 (m)(4), 2.1053	133-ch 6.5.1, 199-ch.4.5	NM
	66A - N41A (HPUE)	27.53(h), 27.53 (m)(4), 2.1053	139-ch.5.6, 199-ch.5.6	NM
	41A - N41A (HPUE)	27.53 (m)(4), 2.1053	199-ch.5.6	P
	2A - N77A (HPUE)	24.238(a), 27.53(l)(n), 2.1053	NA	NM
	5A - N77A (HPUE)	22.917(a), 27.53(l)(n), 2.1053	NA	NM
	12A - N77A (HPUE)	27.53 (g), 27.53(l)(n), 2.1053	NA	NM
	13A - N77A (HPUE)	27.53(c)(f), 27.53(l)(n), 2.1053	NA	NM
	14A - N77A (HPUE)	90.543(e)(f), 27.53(l)(n), 2.1053	NA	NM
	30A - N77A (HPUE)	27.53 (a)(4), 27.53(l)(n), 2.1053	NA	NM
	66A - N77A (HPUE)	27.53(h), 27.53(l)(n), 2.1053	NA	NM
	41A - N77A (HPUE)	27.53 (m)(4), 27.53(l)(n), 2.1053	NA	NM
	2A - N78A	24.238(a), 27.53 (l), 2.1053	NA	P
	5A - N78A	22.917(a), 27.53 (l), 2.1053	NA	NM
7A - N78A	27.53(m)(4), 27.53 (l), 2.1053	NA	NM	
38A - N78A	27.53 (m)(4), 27.53 (l), 2.1053	NA	NM	

* Rx Spurious emission not measured for RSS Parts 132, 133 and 197

P: Pass
 F: Fail
 NM: Not Measured
 NA: Not Applicable

8. Document Revision History

Revision #	Modified by	Revision Details
Rev. 00	R.SIMONINI	First Issue

Annex A. Test & System Description

A.1 Measurement System

Measurements were performed using the following setups.

For WCDMA, a communication tester was used to establish a communication link with the EUT, and the communication tester parameters were set to get the maximum output power from the EUT.

For all other bands, a factory test mode software (NoiseProfilingTool5G V1.0.20) provided by the applicant is used to put device in transmission mode at the maximum output power.

Radiated test setup

Radiated Setup 30 MHz - 1 GHz (Transmitter tests with frequency band > 1GHz)

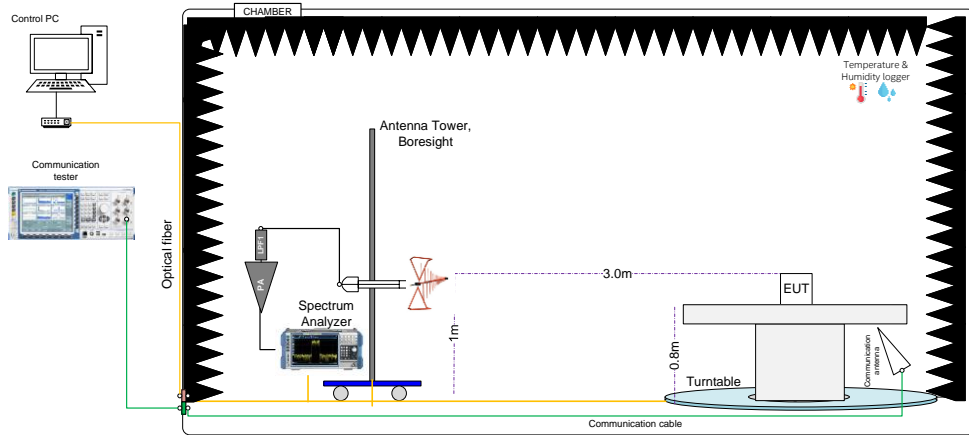

Radiated Setup 30 MHz - 1 GHz (Transmitter tests with frequency band < 1GHz)

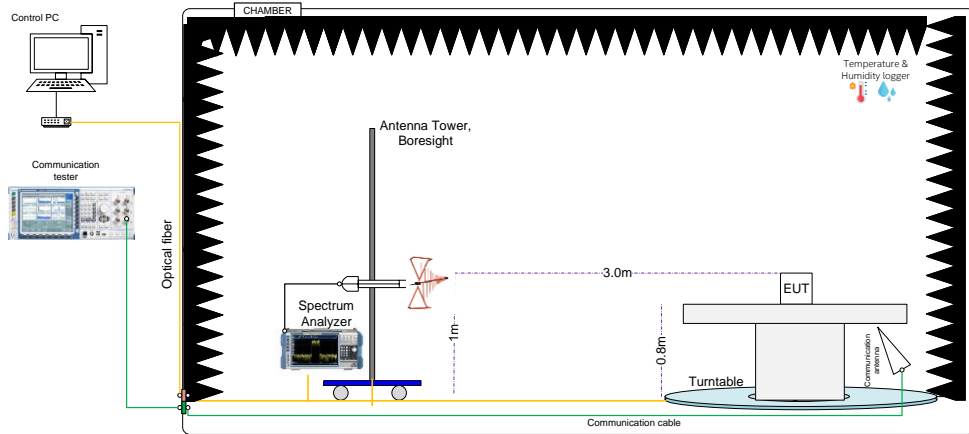

Test Report N° 231128-05.TR06

Radiated Setup 1 GHz - 3 GHz (Transmitter tests with 1GHz < frequency bands < 3GHz)
Radiated Setup 1 GHz - 7.5 GHz (Transmitter tests with 1GHz < frequency bands < 7.5GHz)

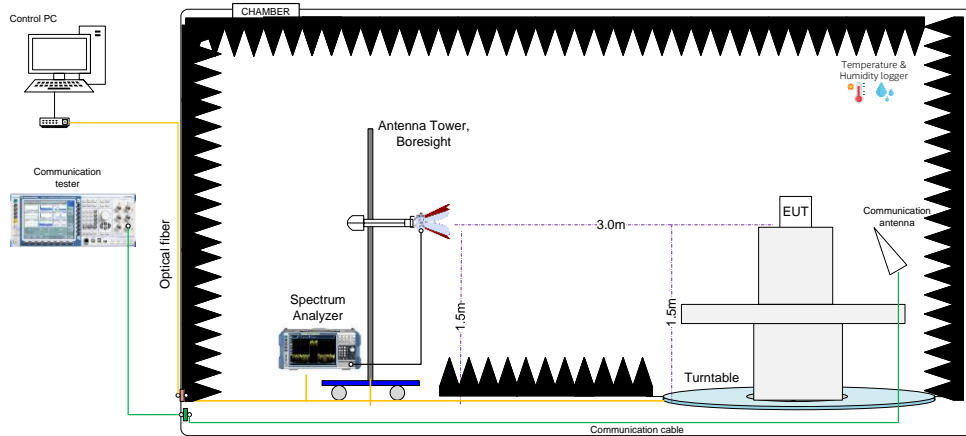

Radiated Setup 3 GHz – 10 GHz (Transmitter tests with 1GHz < frequency bands < 3GHz)
Radiated Setup 7.5 GHz – 10 GHz (Transmitter tests with 1GHz < frequency bands < 7.5GHz)
Radiated Setup 1 GHz – 10 GHz (Transmitter tests with frequency bands < 1GHz)

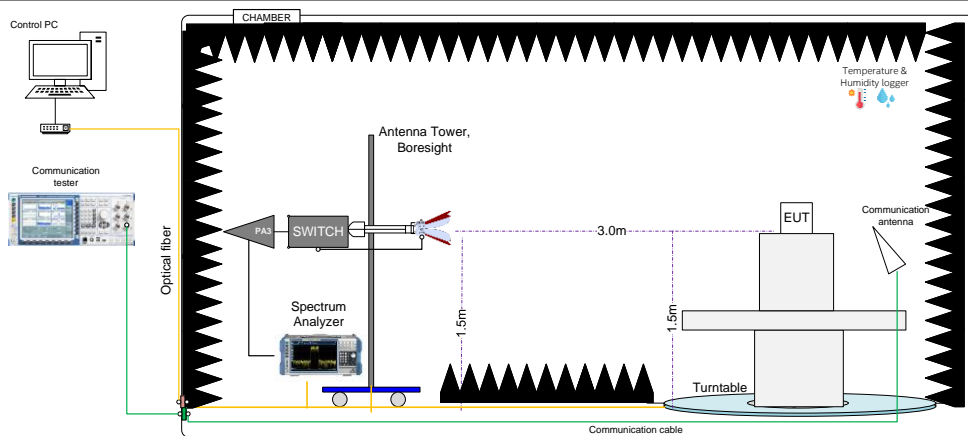

Radiated Setup 10 GHz – 40GHz (Transmitter tests)

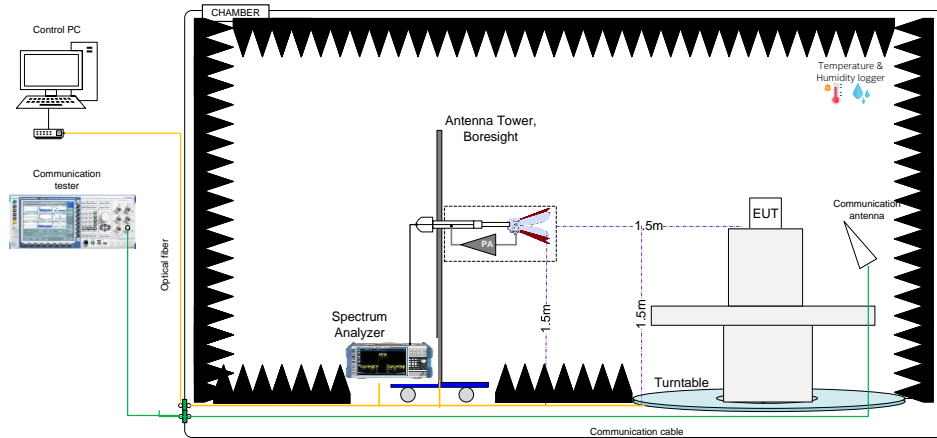

Sample Calculation

The spurious received power P at the spectrum Analyzer is converted to EIRP the equivalent isotropically radiated power, in dBm using the transducer factor F corresponding to the Rx path Loss:

$$F \text{ (dB)} = \text{Free Space Attenuation (dB)} + \text{Cable losses (dB)} - \text{Amplifiers Gain (dB)} - \text{Rx Antenna Gain (dBi)}$$

$$\text{EIRP (dBm)} = P(\text{dBm}) + F \text{ (dB)}$$

$$\text{ERP (dBm)} = \text{EIRP} - 2.15$$

A.2 Test Equipment List

A.2.1 Radiated Setup

Radiated Setup #1

ID#	Device	Type/Model	Serial #	Manufacturer	Cal. Date	Cal. Due Date
006-000	Anechoic chamber	FACT 3	5720	ETS Lindgren	2024-01-17	2026-01-17
006-001	Turntable	-	-	ETS Lindgren	NA	NA
006-008	Measurement Software V11.30.00	EMC32	100623	Rohde & Schwarz	N/A	N/A
147-000	Spectrum analyzer	FSW43	101847	Rohde & Schwarz	2022-11-30	2024-11-30
006-002	Switch & Positioning	EMC center	00159757	ETS Lindgren	N/A	N/A
006-011	Boresight antenna mast	BAM4.0-P	P/278/2890.01	Maturo	N/A	N/A
006-061	Bi-Log Periodic antenna	CBL6143A	61382	Teseq	2022-10-24	2024-10-24
057-000	Double Horn Ridged antenna	3117	167062	ETS-Lindgren	2022-07-08	2024-07-08
007-008	Double Horn Ridged antenna	3116C-PA	00169308bis + 00196308	ETS-Lindgren	2023-05-30	2025-05-30
006-023	Conical log spiral antenna	3102	00154400	ETS Lindgren	NA	NA
301-000	Amplifier 9kHz-1300MHz	8447F	3113A07440	HP	2023-03-03	2024-03-03
261-000*	Amplifier 1GHz-18GHz	3117-PA	00157993	ETS-Lindgren	2023-02-20	2024-03-20
006-067	Low Pass Filter 1.6GHz	LPM17671	G002	Micro-Tronics	2023-08-18	2024-08-18
006-068	RF Switch	RC-2SP6T-40	02112090061	Micro-Circuits	2023-08-22	2024-08-22
006-063	Cable 30cm	PE371-12	-	Pasternack	2023-02-27	2024-02-27
006-064	Cable 30cm	PE371-12	-	Pasternack	2023-02-27	2024-02-27
006-065	Cable 60cm	PE300-24	-	Pasternack	2023-06-02	2024-06-02
006-066	Cable 7m	R286304174	20.46.370	Radiall	2023-08-16	2024-08-16
259-000	Temp & Humidity Logger	RA12E-TH-RAS	RA12-B9BD70	Avtech	2022-06-27	2024-06-27
295-000	Communication tester	CMW500	147712	Rohde & Schwarz	N/A	N/A

N/A: Not Applicable

*Within a grace period of 30 days

Radiated Setup #2

ID#	Device	Type/Model	Serial #	Manufacturer	Cal. Date	Cal. Due Date
007-000	Anechoic chamber*	RFD-FA-100	5996	ETS Lindgren	2024-01-18	2026-01-18
007-002	Turntable	-	-	ETS Lindgren	N/A	N/A
007-003	Antenna Tower	2171B-3.0M	00150123	ETS Lindgren	N/A	N/A
007-006	Switch & Positioner	EMCenter	00151232	ETS Lindgren	N/A	N/A
007-005	Measurement SW, V11.20.00	EMC32	100401	Rohde & Schwarz	N/A	N/A
127-000	Spectrum Analyzer	FSV40	101358	Rohde & Schwarz	2023-01-27	2025-01-27
006-023	Conical log spiral antenna	3102	00154400	ETS Lindgren	NA	NA
007-007	Double Ridge Horn antenna (1- 18GHz)	3117	00152266	ETS Lindgren	2022-03-29	2024-03-29
007-008	Double Horn Ridged antenna	3116C-PA	00169308bis + 00196308	ETS-Lindgren	2023-05-30	2025-05-30
056-000	Double Ridge Horn antenna (1- 18GHz)	3117	157736	ETS-Lindgren	2022-05-05	2024-05-05
056-001*	RF Cable 30cm 6.4GHz-18GHz	UFA147A-0-0120-30050U	MFR 64639223216-001	Micro-Coax	2023-02-17	2024-03-17
056-002*	High Pass Filter 6.4GHz	HPM50112	Micro-Tronics	044	2023-02-02	2024-03-02
261-000*	Amplifier 1GHz-18GHz	3117-PA	00157993	ETS-Lindgren	2023-02-20	2024-03-20
007-022*	RF Cable 1-18GHz, 1.5m	0501050991200GX	19.23.493	Radiall	2023-02-13	2024-03-13
007-020*	RF Cable 1-18GHz, 1.2 m	2301761761200PJ	12.22.1104	Radiall	2023-02-15	2024-03-15
007-011*	RF Cable 1-18GHz – 6.5m	140-8500-11-51	001	Atem	2023-02-15	2024-03-15
007-015*	RF Cable 1GHz-18GHz 1.5m	-	-	Spirent	2023-02-13	2024-03-13
007-014*	RF Cable 18-40 GHz 6m	R286304009	1747364	Radiall	2023-02-16	2024-03-16
007-023*	RF Cable 1m DC-40GHz	PE360-100CM	-	Pasternack	2023-02-14	2024-03-14
007-018*	RF Cable 1-9.5GHz 1.2m	0500990991200KE	-	Radiall	2023-02-13	2024-03-13
349-000	Temp & Humidity Logger	RA12E-TH1-RAS	RA12-D4F8C3	Avtech	2023-11-30	2025-11-30
295-000	Communication tester	CMW500	147712	Rohde & Schwarz	N/A	N/A

N/A: Not Applicable

*Within a grace period of 30 days

A.3 Measurement Uncertainty Evaluation

The system uncertainty evaluation is shown in the table below with a coverage factor of k = 2 to indicate a 95% level of confidence:

Measurement type	Uncertainty	Unit
Tx Radiated test < 1GHz	± 6.40	dB
Tx Radiated test 1GHz - 40 GHz	± 6.04	dB

Annex B. Test Results

The herein test results were performed by:

Test case measurement	Test Personnel
Tx spurious emissions	R.SIMONINI

B.1 Radiated spurious emission

B.1.1 Standard references

Band	FCC part	RSS Part	FCC Limit	IC Limit
WCDMA II LTE 2 LTE 25 N 2 N 25	24.238, 2.1053	133-ch 6.5.1	The power of any emission outside of the authorized operating frequency ranges must be attenuated below the transmitting power (P) by a factor of at least 43 + 10 log(P) dB	(ii) After the first 1.0 MHz, the emission power in any 1 MHz bandwidth shall be attenuated (in dB) below the transmitter output power P (dBW) by at least 43 + 10 log ₁₀ p (watts). If the measurement is performed using 1% of the emission bandwidth, power integration over 1 MHz is required.
WCDMA IV LTE 4 LTE 66 N 66	27.53 (h), 2.1053	139-ch.5.6	The power of any emission outside of the authorized operating frequency ranges must be attenuated below the transmitting power (P) by a factor of at least 43 + 10 log(P) dB	(ii) After the first 1.0 MHz outside the equipment's smallest operating frequency block, which can contain the equipment's occupied bandwidth, the emission power in any 1 MHz bandwidth shall be attenuated below the transmitter output power P (in dBW) by at least 43 + 10 log ₁₀ p (watts) dB.
WCDMA V LTE 5 N 5 LTE 26	22.917, 2.1053 90.691, 22.917, 2.1053	132-ch.5.5	The power of any emission outside of the authorized operating frequency ranges must be attenuated below the transmitting power (P) by a factor of at least 43 + 10 log(P) dB	(ii) After the first 1.0 MHz immediately outside and adjacent to each of the sub-bands, the power of emissions in any 100 kHz bandwidth shall be attenuated (in dB) below the transmitter output power P (dBW) by at least 43 + 10 log ₁₀ p (watts). If the measurement is performed using 1% of the occupied bandwidth, power integration over 100 kHz is required.
LTE 12 LTE 13 LTE 17 LTE 71	27.53 (g)(f), 2.1053	130-ch.4.7	The power of any emission outside a licensee's frequency block shall be attenuated below the transmitting power (P) by a factor of at least 43 + 10 log(P) dB. For operations in the 746-758 MHz, 775-788 MHz, and 805-806 MHz bands, emissions in the band 1559-1610 MHz shall be limited to -70 dBW/MHz equivalent isotropically radiated power (EIRP) for wideband signals, and -80 dBW EIRP for discrete emissions of less than 700 Hz bandwidth.	The power of any emission outside a licensee's frequency block shall be attenuated below the transmitting power (P) by a factor of at least 43 + 10 log(P) dB. In addition, equipment operating in the frequency bands 746-756 MHz and 777-787 MHz shall also comply with the following restrictions: a) The power of any unwanted emissions in any 6.25 kHz bandwidth for all frequencies between 763-775 MHz and 793-806 MHz shall be attenuated below the transmitter power, P (dBW), by at least: (i) 76 + 10 log ₁₀ p (watts), dB, for base and fixed equipment, and (ii) 65 + 10 log ₁₀ p (watts), dB, for mobile and portable equipment. b) The e.i.r.p. in the band 1559-1610 MHz shall not exceed -70 dBW/MHz for wideband signal and -80 dBW for discrete emission with bandwidth less than 700 Hz.
N 77	27.53 (l)(n) 2.1053	NA	(l)(2) For mobile operations in the 3700-3980 MHz band, the conducted power of any emission outside the licensee's authorized bandwidth shall not exceed -13 dBm/MHz. (n)(2) For mobile operations in the 3450-3550 MHz band, the conducted power of any emission outside the licensee's authorized bandwidth shall not exceed -13 dBm/MHz.	NA
N 78	27.53 (l) 2.1053	NA	(l)(2) For mobile operations in the 3700-3980 MHz band, the conducted power of any emission outside the licensee's authorized bandwidth shall not exceed -13 dBm/MHz.	NA

Band	FCC part	RSS Part	FCC Limit	IC Limit																																		
LTE 14	90.543(c)	140-ch.4.4	<p>(e) For operations in the 758-768 MHz and the 788-798 MHz bands, the power of any emission outside the licensee's frequency band(s) of operation shall be attenuated below the transmitter power (P) within the licensed band(s) of operation, measured in watts, in accordance with the following:</p> <p>(1) On all frequencies between 769-775 MHz and 799-805 MHz, by a factor not less than $76 + 10 \log(P)$ dB in a 6.25 kHz band segment, for base and fixed stations.</p> <p>(2) On all frequencies between 769-775 MHz and 799-805 MHz, by a factor not less than $65 + 10 \log(P)$ dB in a 6.25 kHz band segment, for mobile and portable stations.</p> <p>(3) On any frequency between 775-788 MHz, above 805 MHz, and below 758 MHz, by at least $43 + 10 \log(P)$ dB.</p> <p>(4) Compliance with the provisions of paragraphs (e)(1) and (2) of this section is based on the use of measurement instrumentation such that the reading taken with any resolution bandwidth setting should be adjusted to indicate spectral energy in a 6.25 kHz segment.</p> <p>(5) Compliance with the provisions of paragraph (e)(3) of this section is based on the use of measurement instrumentation employing a resolution bandwidth of 100 kHz or greater. However, in the 100 kHz bands immediately outside and adjacent to the frequency block, a resolution bandwidth of 30 kHz may be employed.</p>	<p>The power of any unwanted emission outside the bands 758-768 MHz and 788-798 MHz shall be attenuated below the transmitter output power P in dBW as follows, where p is the transmitter output power in watts:</p> <p>For any frequency between 769-775 MHz and 799-806 MHz:</p> <ul style="list-style-type: none"> • $76 + 10 \log(p)$, dB in a 6.25 kHz band for fixed and base station equipment • $65 + 10 \log(p)$, dB in a 6.25 kHz band for mobile and portable/hand-held equipment <p>For any frequency between 775-788 MHz, above 806 MHz, and below 758 MHz: $43 + 10 \log(p)$, dB in a bandwidth of 100 kHz or greater. However, in the 100 kHz bands immediately outside and adjacent to the frequency bands 758-768 MHz and 788-798 MHz, a resolution bandwidth of 30 kHz may be employed.</p> <p>In addition, the equivalent isotropically radiated power (e.i.r.p.) of all emissions, including harmonics in the band 1559-1610 MHz, shall not exceed -70 dBW/MHz for wideband emissions, and -80 dBW/kHz for discrete emissions of less than 700 Hz bandwidth.</p>																																		
LTE 30 N 30	27.53 (a)(4), 2.1053	195 ch.5.6.2	<p>By a factor of not less than: $43 + 10 \log(P)$ dB on all frequencies between 2305 and 2320 MHz and on all frequencies between 2345 and 2360 MHz that are outside the licensed band(s) of operation, not less than $55 + 10 \log(P)$ dB on all frequencies between 2320 and 2324 MHz and on all frequencies between 2341 and 2345 MHz, not less than $61 + 10 \log(P)$ dB on all frequencies between 2324 and 2328 MHz and on all frequencies between 2337 and 2341 MHz, and not less than $67 + 10 \log(P)$ dB on all frequencies between 2328 and 2337 MHz;</p> <p>(ii) By a factor of not less than $43 + 10 \log(P)$ dB on all frequencies between 2300 and 2305 MHz, $55 + 10 \log(P)$ dB on all frequencies between 2296 and 2300 MHz, $61 + 10 \log(P)$ dB on all frequencies between 2292 and 2296 MHz, $67 + 10 \log(P)$ dB on all frequencies between 2288 and 2292 MHz, and $70 + 10 \log(P)$ dB below 2288 MHz;</p> <p>(iii) By a factor of not less than $43 + 10 \log(P)$ dB on all frequencies between 2360 and 2365 MHz, and not less than $70 + 10 \log(P)$ dB above 2365 MHz.</p>	<table border="1" data-bbox="978 1055 1361 1496"> <thead> <tr> <th>Frequency (MHz)</th> <th>Attenuation (dB)</th> </tr> </thead> <tbody> <tr> <td><2200</td> <td>$43 + 10 \log_{10}(p)$</td> </tr> <tr> <td>2200 - 2288</td> <td>$70 + 10 \log_{10}(p)$</td> </tr> <tr> <td>2288 - 2292</td> <td>$67 + 10 \log_{10}(p)$</td> </tr> <tr> <td>2292 - 2296</td> <td>$61 + 10 \log_{10}(p)$</td> </tr> <tr> <td>2296 - 2300</td> <td>$55 + 10 \log_{10}(p)$</td> </tr> <tr> <td>2300 - 2305</td> <td>$43 + 10 \log_{10}(p)$</td> </tr> <tr> <td>2305 - 2320</td> <td>$43 + 10 \log_{10}(p)$</td> </tr> <tr> <td>2320 - 2324</td> <td>$55 + 10 \log_{10}(p)$</td> </tr> <tr> <td>2324 - 2328</td> <td>$61 + 10 \log_{10}(p)$</td> </tr> <tr> <td>2328 - 2337</td> <td>$67 + 10 \log_{10}(p)$</td> </tr> <tr> <td>2337 - 2341</td> <td>$61 + 10 \log_{10}(p)$</td> </tr> <tr> <td>2341 - 2345</td> <td>$55 + 10 \log_{10}(p)$</td> </tr> <tr> <td>2345 - 2360</td> <td>$43 + 10 \log_{10}(p)$</td> </tr> <tr> <td>2360 - 2365</td> <td>$43 + 10 \log_{10}(p)$</td> </tr> <tr> <td>2365 - 2395</td> <td>$70 + 10 \log_{10}(p)$</td> </tr> <tr> <td>>2395</td> <td>$43 + 10 \log_{10}(p)$</td> </tr> </tbody> </table>	Frequency (MHz)	Attenuation (dB)	<2200	$43 + 10 \log_{10}(p)$	2200 - 2288	$70 + 10 \log_{10}(p)$	2288 - 2292	$67 + 10 \log_{10}(p)$	2292 - 2296	$61 + 10 \log_{10}(p)$	2296 - 2300	$55 + 10 \log_{10}(p)$	2300 - 2305	$43 + 10 \log_{10}(p)$	2305 - 2320	$43 + 10 \log_{10}(p)$	2320 - 2324	$55 + 10 \log_{10}(p)$	2324 - 2328	$61 + 10 \log_{10}(p)$	2328 - 2337	$67 + 10 \log_{10}(p)$	2337 - 2341	$61 + 10 \log_{10}(p)$	2341 - 2345	$55 + 10 \log_{10}(p)$	2345 - 2360	$43 + 10 \log_{10}(p)$	2360 - 2365	$43 + 10 \log_{10}(p)$	2365 - 2395	$70 + 10 \log_{10}(p)$	>2395	$43 + 10 \log_{10}(p)$
Frequency (MHz)	Attenuation (dB)																																					
<2200	$43 + 10 \log_{10}(p)$																																					
2200 - 2288	$70 + 10 \log_{10}(p)$																																					
2288 - 2292	$67 + 10 \log_{10}(p)$																																					
2292 - 2296	$61 + 10 \log_{10}(p)$																																					
2296 - 2300	$55 + 10 \log_{10}(p)$																																					
2300 - 2305	$43 + 10 \log_{10}(p)$																																					
2305 - 2320	$43 + 10 \log_{10}(p)$																																					
2320 - 2324	$55 + 10 \log_{10}(p)$																																					
2324 - 2328	$61 + 10 \log_{10}(p)$																																					
2328 - 2337	$67 + 10 \log_{10}(p)$																																					
2337 - 2341	$61 + 10 \log_{10}(p)$																																					
2341 - 2345	$55 + 10 \log_{10}(p)$																																					
2345 - 2360	$43 + 10 \log_{10}(p)$																																					
2360 - 2365	$43 + 10 \log_{10}(p)$																																					
2365 - 2395	$70 + 10 \log_{10}(p)$																																					
>2395	$43 + 10 \log_{10}(p)$																																					
LTE 7 LTE 38 LTE 41 N 7 N 38 N 41	27.53 (m), 2.1053	199-ch.5.6	<p>For mobile digital stations, the attenuation factor shall be not less than $40 + 10 \log(P)$ dB on all frequencies between the channel edge and 5 megahertz from the channel edge, $43 + 10 \log(P)$ dB on all frequencies between 5 megahertz and X megahertz from the channel edge, and $55 + 10 \log(P)$ dB on all frequencies more than X megahertz from the channel edge, where X is the greater of 6 megahertz or the actual emission bandwidth as defined in paragraph (m)(6) of this section. In addition, the attenuation factor shall not be less than $43 + 10 \log(P)$ dB on all frequencies between 2490.5 MHz and 2496 MHz and $55 + 10 \log(P)$ dB at or below 2490.5 MHz.</p>	<p>for mobile subscriber equipment, the power of any unwanted emissions measured as above shall be attenuated (in dB) below the transmitter power, P (dBW), by at least:</p> <p>(i) $40 + 10 \log_{10} p$ from the channel edges to 5 MHz away</p> <p>(ii) $43 + 10 \log_{10} p$ between 5 MHz and X MHz from the channel edges, and</p> <p>(iii) $55 + 10 \log_{10} p$ at X MHz and beyond from the channel edges</p> <p>In addition, the attenuation shall not be less than $43 + 10 \log_{10} p$ on all frequencies between 2490.5 MHz and 2496 MHz, and $55 + 10 \log_{10} p$ at or below 2490.5 MHz.</p>																																		

Band	FCC part	RSS Part	FCC Limit	IC Limit																			
LTE 48 LTE 42	96.41(e)		<p>(ii) Except as otherwise specified in paragraph (e)(2) of this section, for channel and frequency assignments made by a CBSD to End User Devices, the conducted power of any End User Device emission outside the fundamental emission (whether in or outside of the authorized band) shall not exceed -13 dBm/MHz within 0 to B megahertz (where B is the bandwidth in megahertz of the assigned channel or multiple contiguous channels of the End User Device) above the upper CBSD-assigned channel edge and within 0 to B megahertz below the lower CBSD-assigned channel edge. At all frequencies greater than B megahertz above the upper CBSD assigned channel edge and less than B megahertz below the lower CBSD-assigned channel edge, the conducted power of any End User Device emission shall not exceed -25 dBm/MHz. Notwithstanding the emission limits in this paragraph, the Adjacent Channel Leakage Ratio for End User Devices shall be at least 30 dB.</p> <p>(2) Additional protection levels. Notwithstanding paragraph (e)(1) of this section, for CBSDs and End User Devices, the conducted power of emissions below 3540 MHz or above 3710 MHz shall not exceed -25 dBm/MHz, and the conducted power of emissions below 3530 MHz or above 3720 MHz shall not exceed -40dBm/MHz</p>																				
LTE48		192- ch.5.6	-	<p>Subscriber equipment shall have the TRP (per cell) or conducted power (per single antenna connector), where applicable, of unwanted emission outside the frequency block group not exceeding the following, where B is the frequency block group in MHz as shown in table 5.</p> <table border="1" data-bbox="906 1151 1544 1424"> <thead> <tr> <th rowspan="2">Frequency block group (B)</th> <th colspan="4">Offset frequency from the edge of the frequency block group (MHz)</th> </tr> <tr> <th>0-1</th> <th>1-5</th> <th>5-B</th> <th>>B</th> </tr> </thead> <tbody> <tr> <td>10 MHz, 20MHz, 30 MHz and 40 MHz</td> <td>- 13dBm/1% of B</td> <td>-10 dBm/MHz</td> <td>-13 dBm/MHz</td> <td>-25 dBm/MHz</td> </tr> <tr> <td>> 40 MHz</td> <td>-24 dBm/30 kHz</td> <td>-10 dBm/MHz</td> <td>-13 dBm/MHz</td> <td>-25 dBm/MHz</td> </tr> </tbody> </table> <p>Notwithstanding the above limits in 8.7.2 and 8.7.3, the TRP (per cell) or conducted power (per single antenna connector), where applicable, for the unwanted emissions shall not exceed: for subscriber equipment: -30 dBm/MHz in the frequency range greater than (B+5) MHz from the edge of the frequency band, where B is the frequency block group in MHz</p>	Frequency block group (B)	Offset frequency from the edge of the frequency block group (MHz)				0-1	1-5	5-B	>B	10 MHz, 20MHz, 30 MHz and 40 MHz	- 13dBm/1% of B	-10 dBm/MHz	-13 dBm/MHz	-25 dBm/MHz	> 40 MHz	-24 dBm/30 kHz	-10 dBm/MHz	-13 dBm/MHz	-25 dBm/MHz
Frequency block group (B)	Offset frequency from the edge of the frequency block group (MHz)																						
	0-1	1-5	5-B	>B																			
10 MHz, 20MHz, 30 MHz and 40 MHz	- 13dBm/1% of B	-10 dBm/MHz	-13 dBm/MHz	-25 dBm/MHz																			
> 40 MHz	-24 dBm/30 kHz	-10 dBm/MHz	-13 dBm/MHz	-25 dBm/MHz																			
LTE 48		197- ch.5.7	-	<p>The unwanted emissions shall be measured at the frequencies of the highest and lowest channel of all bandwidths and types of modulation that the equipment can operate with a resolution bandwidth of 1 MHz or less, but at least 1% of the occupied bandwidth of the transmitter, provided that the measured power is integrated over a 1 MHz bandwidth.</p> <p>The power of any emissions outside the frequency band 3650-3700 MHz shall be attenuated below the channel transmitter power P (dBW) by $43 + 10 \text{ Log } (p)$, where p is measured in watts</p>																			

B.1.2 Test procedure

The setup described in Test & System Description section was used to measure the radiated spurious emissions. Depending on the frequency range and bands being tested, different antennas and filters were used. The final measurement is done by varying the antenna height from 1 to 4 meters, the EUT azimuth over 360° and for both Vertical and Horizontal polarizations.

B.1.3 Test Results

B.1.3.1 WCDMA

WCDMA 2 – Antenna Vendor 1

30 MHz to 26.5 GHz - Radiated Spurious WCDMA 2- QPSK - Low channel – 1852.4 MHz				
Frequency	RMS (EIRP)	Limit	Margin	Correction Factor
MHz	dBm	dBm	dB	dB
104.7	-53.0	-13.0	40.0	-101.0
1694.0	-42.5	-13.0	29.5	-63.6
2362.0	-38.2	-13.0	25.2	-60.1
2860.0	-36.8	-13.0	23.8	-59.2
9687.0	-48.5	-13.0	35.5	-86.0
16000.5	-55.1	-13.0	42.1	-91.2

WCDMA 4 - Antenna Vendor 1

30 MHz to 18GHz - Radiated Spurious WCDMA 4- QPSK - High channel – 1752.6 MHz				
Frequency	RMS (EIRP)	Limit	Margin	Correction Factor
MHz	dBm	dBm	dB	dB
104.7	-53.1	-13.0	40.1	-101.0
1384.0	-44.1	-13.0	31.1	-63.9
2384.0	-38.0	-13.0	25.0	-59.9
2839.5	-36.9	-13.0	23.9	-59.1
9781.5	-48.2	-13.0	35.2	-85.8
16000.0	-51.9	-13.0	38.9	-91.2

WCDMA 5 - Antenna Vendor 2

30 MHz to 18 GHz - Radiated Spurious WCDMA 5- QPSK - Low channel – 826.4 MHz				
Frequency	RMS (ERP)	Limit	Margin	Correction Factor
MHz	dBm	dBm	dB	dB
38.8	-51.5	-13.0	38.5	-66.2
106.7	-59.1	-13.0	46.1	-73.4
153.8	-56	-13.0	43	-73.0
549.6	-48.3	-13.0	35.3	-65.4
988.5	-49	-13.0	36	-62.2
2651.5	-52.6	-13.0	39.6	-94.1

B.1.3.1 LTE
LTE 7 - Antenna Vendor 2

30MHz to 26.5GHz - Radiated Spurious LTE 7 - QPSK - High channel – 2560 MHz BW 20 MHz				
Frequency	RMS (EIRP)	Limit	Margin	Correction Factor
MHz	dBm	dBm	dB	dB
103.3	-53.6	-25.0	28.6	-101.2
1232.0	-51.5	-25.0	26.5	-63.3
2183.5	-47.4	-25.0	22.4	-60.9
2665.0	-49.3	-25.0	24.3	-59.2
9771.5	-48.1	-25.0	23.1	-85.8
16000.0	-53.5	-25.0	28.5	-91.2

LTE 12 - Antenna Vendor 1

30MHz to 18GHz - Radiated Spurious LTE 12 - QPSK - Low channel – 704 MHz BW 10 MHz				
Frequency	RMS (ERP)	Limit	Margin	Correction Factor
MHz	dBm	dBm	dB	dB
50.0	-54.6	-13.0	41.6	-71.4
153.8	-56.5	-13.0	43.5	-73.0
250.0	-57.1	-13.0	44.1	-71.8
550.1	-49.1	-13.0	36.1	-65.4
961.0	-49.2	-13.0	36.2	-62.4
2194.0	-49.3	-13.0	36.3	-97.2

LTE 13 - Antenna Vendor 1

30MHz to 18GHz - Radiated Spurious LTE 13 - QPSK - High channel – 784.5 MHz BW 5 MHz				
Frequency	RMS (ERP)	Limit	Margin	Correction Factor
MHz	dBm	dBm	dB	dB
39.0	-50.8	-13.0	37.8	-66.3
153.8	-56	-13.0	43	-73.0
250.0	-56.7	-13.0	43.7	-71.8
548.1	-49.1	-13.0	36.1	-65.5
990.2	-48.7	-13.0	35.7	-62.1
1607.0	-54.9	-40.0	14.9	-102.7

LTE 14 - Antenna Vendor 1

30MHz to 18GHz - Radiated Spurious LTE 14 - QPSK - Mid channel – 793 MHz BW 5 MHz				
Frequency	RMS (ERP)	Limit	Margin	Correction Factor
MHz	dBm	dBm	dB	dB
50.0	-52.9	-13.0	39.9	-71.4
138.4	-56.5	-13.0	43.5	-72.2
153.8	-55.4	-13.0	42.4	-73.0
550.7	-49	-13.0	36	-65.4
999.4	-48.4	-13.0	35.4	-62.1
1600.5	-55.1	-40.0	15.1	-102.8

LTE 25 - Antenna Vendor 1

30MHz to 26.5GHz - Radiated Spurious LTE 25 - QPSK - Low channel – 1860 MHz BW 20 MHz				
Frequency	RMS (EIRP)	Limit	Margin	Correction Factor
MHz	dBm	dBm	dB	dB
104.7	-53.0	-13.0	40.0	-101.0
1679.0	-42.8	-13.0	29.8	-63.9
2160.0	-39.0	-13.0	26.0	-60.8
2905.5	-37.0	-13.0	24.0	-59.1
9917.0	-48.0	-13.0	35.0	-85.6
16000.0	-56.7	-13.0	43.7	-91.2

LTE 26 - Antenna Vendor 2

30MHz to 18GHz - Radiated Spurious LTE 26 - QPSK - Low channel – 831.5 MHz BW 15 MHz				
Frequency	RMS (ERP)	Limit	Margin	Correction Factor
MHz	dBm	dBm	dB	dB
39.3	-50.9	-13.0	37.9	-66.5
106.7	-58.7	-13.0	45.7	-73.4
153.8	-55.8	-13.0	42.8	-73.0
548.3	-48.7	-13.0	35.7	-65.5
990.1	-48.1	-13.0	35.1	-62.1
2183.5	-50.4	-13.0	37.4	-97.4

LTE 30 - Antenna Vendor 2

30MHz to 26.5GHz - Radiated Spurious LTE 30 - QPSK - Mid channel – 2310 MHz BW 10 MHz				
Frequency	RMS (EIRP)	Limit	Margin	Correction Factor
MHz	dBm	dBm	dB	dB
101.9	-53.4	-40.0	13.4	-101.6
1244.0	-51.2	-40.0	11.2	-63.1
1841.0	-48.9	-40.0	8.9	-61.0
2881.5	-46.5	-40.0	6.5	-59.1
9784.5	-48.3	-40.0	8.3	-85.6
12000.0	-58.3	-40.0	18.3	-92.6

LTE 41 - Antenna Vendor 2

30MHz to 40GHz - Radiated Spurious LTE 41 - QPSK - High channel – 2680 MHz BW 20 MHz				
Frequency	RMS (EIRP)	Limit	Margin	Correction Factor
MHz	dBm	dBm	dB	dB
101.9	-53.5	-25.0	28.5	-101.6
1303.5	-47.1	-25.0	22.1	-63.3
2085.0	-44.1	-25.0	19.1	-60.5
2922.0	-41.9	-25.0	16.9	-59.1
9829.5	-49.6	-25.0	24.6	-85.9
21154.0	-57.2	-25.0	32.2	-84.5

LTE 48 - Antenna Vendor 1

30MHz to 40GHz – Tx Radiated Spurious LTE 48 - QPSK - Mid channel – 3625 MHz BW 20 MHz				
Frequency	RMS (EIRP)	Limit	Margin	Correction Factor
MHz	dBm	dBm	dB	dB
101.9	-53.4	-40.0	13.4	-101.6
2183.5	-46.5	-40.0	6.5	-79.5
3292.0	-47.9	-40.0	7.9	-76.5
6195.2	-50.5	-40.0	10.5	-79.2
7232.0	-45.9	-40.0	5.9	-94.2
14464.5	-57.4	-40.0	17.4	-92.6
21696.5	-53.1	-40.0	13.1	-85.6

LTE 66 - Antenna Vendor 1

30MHz to 18GHz – Tx Radiated Spurious LTE 66 - QPSK - High channel – 1770 MHz BW 20 MHz				
Frequency	RMS (EIRP)	Limit	Margin	Correction Factor
MHz	dBm	dBm	dB	dB
103.3	-53.0	-13.0	40.0	-101.2
1283.0	-43.5	-13.0	30.5	-63.3
2174.5	-38.6	-13.0	25.6	-60.9
2832.0	-36.9	-13.0	23.9	-59.1
9705.5	-48.3	-13.0	35.3	-85.9
16000.0	-56.9	-13.0	43.9	-91.2

LTE 71 - Antenna Vendor 1

30MHz to 10GHz – Tx Radiated Spurious LTE 71 - QPSK - Mid channel – 680.5 MHz BW 20 MHz				
Frequency	RMS (ERP)	Limit	Margin	Correction Factor
MHz	dBm	dBm	dB	dB
38.8	-49.9	-13.0	36.9	-66.2
101.9	-57.8	-13.0	44.8	-74.2
246.1	-56.6	-13.0	43.6	-71.9
546.9	-49.3	-13.0	36.3	-65.6
984.6	-48.7	-13.0	35.7	-62.1
2189.5	-49.5	-13.0	36.5	-97.2

B.1.3.2 5G NR
N5 - Antenna Vendor 2

30MHz to 18GHz – Tx Radiated Spurious N5 - QPSK - Low channel – 834 MHz BW 20 MHz				
Frequency	RMS (ERP)	Limit	Margin	Correction Factor
MHz	dBm	dBm	dB	dB
35.9	-50.9	-13.0	37.9	-64.7
106.7	-58.5	-13.0	45.5	-73.4
246.1	-57.2	-13.0	44.2	-71.9
551.5	-49.5	-13.0	36.5	-65.3
887.6	-49	-13.0	36	-62.8
2192.5	-50.3	-13.0	37.3	-97.2

N7 - Antenna Vendor 2

30MHz to 26.5GHz – Tx Radiated Spurious N7 - QPSK - Low channel – 2510 MHz BW 20 MHz				
Frequency	RMS (EIRP)	Limit	Margin	Correction Factor
MHz	dBm	dBm	dB	dB
101.9	-53.4	-25.0	28.4	-101.6
1221.5	-51.5	-25.0	26.5	-63.4
2190.0	-47.6	-25.0	22.6	-60.8
2651.5	-48.9	-25.0	23.9	-59.2
9681.0	-48.4	-25.0	23.4	-85.9
24423.2	-54.9	-25.0	29.9	-82.7

N25 - Antenna Vendor 1

30MHz to 26.5GHz – Tx Radiated Spurious N25 - QPSK - Low channel – 1860 MHz BW 20 MHz				
Frequency	RMS (EIRP)	Limit	Margin	Correction Factor
MHz	dBm	dBm	dB	dB
104.7	-52.9	-13.0	39.9	-101.0
1411.0	-44.4	-13.0	31.4	-64.3
2248.0	-38.0	-13.0	25.0	-60.3
2865.5	-37.2	-13.0	24.2	-59.2
9788.0	-48.3	-13.0	35.3	-85.7
15461.0	-58.9	-13.0	45.9	-90.9

N30 - Antenna Vendor 2

30MHz to 26.5GHz – Tx Radiated Spurious N30 - QPSK - Mid channel – 2310 MHz BW 10 MHz				
Frequency	RMS (EIRP)	Limit	Margin	Correction Factor
MHz	dBm	dBm	dB	dB
104.7	-53.7	-40.0	13.7	-101.0
1339.0	-52.4	-40.0	12.4	-63.6
2184.0	-47.5	-40.0	7.5	-60.9
2902.0	-47.2	-40.0	7.2	-59.1
9715.0	-48.4	-40.0	8.4	-85.9
20811.6	-56.5	-40.0	16.5	-85.0

N41 HPUE - Antenna Vendor 2

30MHz to 26.5GHz – Tx Radiated Spurious N41_HPUE - QPSK - Mid channel – 2592.99 MHz BW 80 MHz				
Frequency	RMS (EIRP)	Limit	Margin	Correction Factor
MHz	dBm	dBm	dB	dB
104.7	-53.5	-25.0	28.5	-101.0
1347.5	-47.8	-25.0	22.8	-63.6
2179.5	-43.4	-25.0	18.4	-60.9
2927.5	-41.9	-25.0	16.9	-59.1
9772.0	-49.3	-25.0	24.3	-85.7
16000.0	-56.5	-25.0	31.5	-91.2

N66 - Antenna Vendor 1

30MHz to 18GHz – Tx Radiated Spurious N66 - QPSK - High channel – 1760 MHz BW 40 MHz				
Frequency	RMS (EIRP)	Limit	Margin	Correction Factor
MHz	dBm	dBm	dB	dB
103.3	-53.1	-13.0	40.1	-101.2
1321.0	-43.3	-13.0	30.3	-63.3
2265.0	-38.0	-13.0	25.0	-60.2
2805.5	-36.9	-13.0	23.9	-59.1
9880.5	-47.6	-13.0	34.6	-85.9
15443.0	-59.1	-13.0	46.1	-90.9

N77_HPUE - Antenna Vendor 1

**30MHz to 40GHz – Tx Radiated Spurious
N77_HPUE - QPSK - Low channel – 3750 MHz
BW 100 MHz**

Frequency	RMS (EIRP)	Limit	Margin	Correction Factor
MHz	dBm	dBm	dB	dB
104.7	-53.0	-13.0	40.0	-101.0
2183.5	-46.7	-13.0	33.7	-79.5
2567.0	-48.2	-13.0	35.2	-78.2
5225.5	-51.3	-13.0	38.3	-81.6
7186.0	-55.4	-40.0	15.4	-93.9
33047.0	-53.2	-13.0	40.2	-81.0

B.1.3.3 LTE ULCA-INTRA
LTE 5B_CA – Antenna Vendor 2

30MHz to 18GHz – Tx Radiated Spurious LTE 5B_CA – QPSK – Low channel – 829/838.9 MHz BW 10/10 MHz				
Frequency	RMS (ERP)	Limit	Margin	Correction Factor
MHz	dBm	dBm	dB	dB
39.2	-51.4	-13.0	38.4	-66.4
138.4	-57.9	-13.0	44.9	-72.2
153.8	-56.1	-13.0	43.1	-73.0
552.4	-49.5	-13.0	36.5	-65.3
983.0	-48.8	-13.0	35.8	-62.1
2188.5	-50.2	-13.0	37.2	-97.3

LTE 66B_CA – Antenna Vendor 1

30MHz to 18GHz – Tx Radiated Spurious LTE 66B_CA – QPSK – High channel – 1765.1/1775 MHz BW 10/10 MHz				
Frequency	RMS (EIRP)	Limit	Margin	Correction Factor
MHz	dBm	dBm	dB	dB
103.3	-53.2	-13.0	40.2	-101.2
1323.5	-43.6	-13.0	30.6	-63.4
2369.5	-38.0	-13.0	25.0	-60.0
2852.0	-36.9	-13.0	23.9	-59.1
9875.5	-48.2	-13.0	35.2	-85.7
15428.5	-58.5	-13.0	45.5	-90.8

LTE 7C_CA – Antenna Vendor 2

30MHz to 26.5GHz – Tx Radiated Spurious LTE 7C_CA – QPSK – Low channel – 2510/2529.8 MHz BW 20/20 MHz				
Frequency	RMS (EIRP)	Limit	Margin	Correction Factor
MHz	dBm	dBm	dB	dB
104.7	-53.5	-25.0	28.5	-101.0
1806.0	-41.0	-25.0	16.0	-61.8
2239.0	-38.2	-25.0	13.2	-60.4
2928.0	-37.2	-25.0	12.2	-59.1
9784.5	-48.1	-25.0	23.1	-85.6
24408.1	-54.7	-25.0	29.7	-82.6

LTE 41C_CA – Antenna Vendor 2

30MHz to 26.5GHz – Tx Radiated Spurious LTE 41C_CA – QPSK – High channel – 2660.2/2680 MHz BW 20/20 MHz				
Frequency	RMS (EIRP)	Limit	Margin	Correction Factor
MHz	dBm	dBm	dB	dB
104.7	-53.8	-25.0	28.8	-101.0
1703.0	-46.8	-25.0	21.8	-63.4
2194.5	-43.0	-25.0	18.0	-60.8
2946.0	-41.8	-25.0	16.8	-59.1
9869.0	-49.2	-25.0	24.2	-85.5
20992.0	-57.2	-25.0	32.2	-84.6

LTE 48C_CA – Antenna Vendor 1

30MHz to 40GHz – Tx Radiated Spurious LTE 48C_CA – QPSK – Mid channel – 3615.1/3634.9 MHz BW 20/20 MHz				
Frequency	RMS (EIRP)	Limit	Margin	Correction Factor
MHz	dBm	dBm	dB	dB
104.7	-52.7	-40.0	12.7	-101.0
2190.0	-46.9	-40.0	6.9	-79.4
3222.0	-48.1	-40.0	8.1	-76.7
6237.8	-50.8	-40.0	10.8	-79.1
7176.5	-55.9	-40.0	15.9	-94.0
16000.5	-54.0	-40.0	14.0	-91.2

B.1.3.4 LTE ULCA-INTER
LTE 2A-13A – Antenna Vendor 1

30MHz to 26.5GHz – Tx Radiated Spurious LTE 2A-13A – QPSK – Mid/Mid channel – 1880/782 MHz BW 20/10 MHz				
Frequency	RMS (EIRP)	Limit	Margin	Correction Factor
MHz	dBm	dBm	dB	dB
996.7	-46.3	-13.0	33.3	-62.1
1300.0	-43.5	-13.0	30.5	-63.3
2262.0	-37.7	-13.0	24.7	-60.2
2862.0	-36.9	-13.0	23.9	-59.2
9785.5	-48.3	-13.0	35.3	-85.7
16000.0	-54.6	-13.0	41.6	-91.2

LTE 2A-48A – Antenna Vendor 1

30MHz to 40GHz – Tx Radiated Spurious LTE 2A-48A – QPSK – Mid/Mid channel – 1880/3625 MHz BW 20/20 MHz				
Frequency	RMS (EIRP)	Limit	Margin	Correction Factor
MHz	dBm	dBm	dB	dB
104.7	-53.2	-40.0	13.2	-101.0
1746.5	-46.0	-40.0	6.0	-81.7
5209.0	-51.0	-40.0	11.0	-81.6
6238.0	-50.7	-40.0	10.7	-79.1
7250.0	-52.1	-40.0	12.1	-94.4
16000.0	-55.0	-40.0	15.0	-91.2
21749.5	-55.9	-40.0	15.9	-85.7

LTE 5A-7A – Antenna Vendor 1

30MHz to 26.5GHz – Tx Radiated Spurious LTE 5A-7A – QPSK – Low/High channel – 829/2560 MHz BW 10/20 MHz				
Frequency	RMS (EIRP)	Limit	Margin	Correction Factor
MHz	dBm	dBm	dB	dB
991.6	-46.5	-25.0	21.5	-62.1
1270.5	-43.0	-25.0	18.0	-63.2
2137.0	-38.9	-25.0	13.9	-60.6
2933.5	-37.0	-25.0	12.0	-59.1
9834.5	-48.3	-25.0	23.3	-85.8
16000.0	-56.4	-25.0	31.4	-91.2

LTE 5A-66A – Antenna Vendor 1

30MHz to 18GHz – Tx Radiated Spurious LTE 5A-66A – QPSK – Low/High channel – 829/1770 MHz BW 10/20 MHz				
Frequency	RMS (EIRP)	Limit	Margin	Correction Factor
MHz	dBm	dBm	dB	dB
969.1	-46.6	-13.0	33.6	-62.3
1278.5	-43.3	-13.0	30.3	-63.3
2251.5	-38.0	-13.0	25.0	-60.3
2873.0	-37.1	-13.0	24.1	-59.1
9820.0	-48.4	-13.0	35.4	-85.8
16000.5	-56.4	-13.0	43.4	-91.2

LTE 12A-30A – Antenna Vendor 2

30MHz to 26.5GHz – Tx Radiated Spurious LTE 12A-30A – QPSK – Low/Mid channel – 704/2310 MHz BW 10/10 MHz				
Frequency	RMS (EIRP)	Limit	Margin	Correction Factor
MHz	dBm	dBm	dB	dB
996.8	-46.6	-40.0	6.6	-62.1
1224.0	-51.6	-40.0	11.6	-61.1
2194.5	-47.1	-40.0	7.1	-57.4
2519.5	-46.9	-40.0	6.9	-56.2
9386.0	-48.4	-40.0	8.4	-86.2
16000.5	-53.2	-40.0	13.2	-91.2

LTE 12A-66A – Antenna Vendor 1

30MHz to 18GHz – Tx Radiated Spurious LTE 12A-66A – QPSK – High/High channel – 711/1770 MHz BW 10/20 MHz				
Frequency	RMS (EIRP)	Limit	Margin	Correction Factor
MHz	dBm	dBm	dB	dB
976.5	-46.8	-13.0	33.8	-62.2
1315.5	-43.5	-13.0	30.5	-63.3
2461.5	-38.1	-13.0	25.1	-59.8
2875.5	-37.2	-13.0	24.2	-59.1
9752.5	-48.3	-13.0	35.3	-85.7
16000.5	-56.1	-13.0	43.1	-91.2

LTE 13A-48A – Antenna Vendor 1

30MHz to 40GHz – Tx Radiated Spurious LTE 13A-48A – QPSK – Mid/Mid channel – 782/3625 MHz BW 10/20 MHz				
Frequency	RMS (EIRP)	Limit	Margin	Correction Factor
MHz	dBm	dBm	dB	dB
37.5	-48.9	-40.0	8.9	-65.5
101.9	-53.8	-40.0	13.8	-74.2
153.8	-55.3	-40.0	15.3	-73.0
552.1	-46.7	-40.0	6.7	-65.3
969.8	-46.7	-40.0	6.7	-62.3
2190.0	-47.7	-40.0	7.7	-88.9
5435.2	-50.9	-40.0	10.9	-81.3
6321.0	-51.4	-40.0	11.4	-79.3
9989.2	-56.1	-40.0	16.1	-92.3
10874.5	-57.9	-40.0	17.9	-85.1
16000.0	-58.5	-40.0	18.5	-91.2

LTE 14A-30A – Antenna Vendor 2

30MHz to 26.5GHz – Tx Radiated Spurious LTE 14A-30A – QPSK – Mid/Mid channel – 793/2310 MHz BW 10/10 MHz				
Frequency	RMS (EIRP)	Limit	Margin	Correction Factor
MHz	dBm	dBm	dB	dB
966.3	-46.5	-40.0	6.5	-62.3
1828.5	-50.8	-40.0	10.8	-58.7
2192.5	-46.5	-40.0	6.5	-57.5
2853.0	-47.6	-40.0	7.6	-55.7
9903.0	-48.1	-40.0	8.1	-85.5
22333.6	-55.5	-40.0	15.5	-82.9

LTE 14A-66A – Antenna Vendor 1

30MHz to 18GHz – Tx Radiated Spurious LTE 14A-66A – QPSK – Mid/High channel – 793/1770 MHz BW 10/20 MHz				
Frequency	RMS (EIRP)	Limit	Margin	Correction Factor
MHz	dBm	dBm	dB	dB
986.6	-47.1	-13.0	34.1	-62.2
1272.0	-43.3	-13.0	30.3	-63.2
2261.0	-38.0	-13.0	25.0	-60.2
2868.5	-37.2	-13.0	24.2	-59.2
9809.0	-48.1	-13.0	35.1	-85.8
16948.0	-58.8	-13.0	45.8	-90.1

LTE 25A-26A – Antenna Vendor 1

30MHz to 26.5GHz – Tx Radiated Spurious
LTE 25A-26A – QPSK – Low/Low channel – 1860/831.5 MHz
BW 20/15 MHz

Frequency	RMS (EIRP)	Limit	Margin	Correction Factor
MHz	dBm	dBm	dB	dB
992.2	-47.0	-13.0	34.0	-62.1
1304.0	-43.2	-13.0	30.2	-63.3
2287.5	-38.2	-13.0	25.2	-60.3
2888.5	-37.0	-13.0	24.0	-59.1
9950.0	-47.6	-13.0	34.6	-85.8
16000.0	-55.5	-13.0	42.5	-91.2

B.1.3.5 EN-DC

LTE 5A –N2A – Antenna Vendor 1

30MHz to 26.5GHz – Tx Radiated Spurious LTE 5A- N2A – QPSK – Low/Mid channel – 829/1880 MHz BW 10/20 MHz				
Frequency	RMS (EIRP)	Limit	Margin	Correction Factor
MHz	dBm	dBm	dB	dB
977.4	-46.8	-13.0	33.8	-62.2
1259.0	-42.9	-13.0	29.9	-63.1
2392.5	-38.0	-13.0	25.0	-60.0
2827.5	-36.9	-13.0	23.9	-59.1
9775.5	-48.2	-13.0	35.2	-85.7
16000.0	-54.1	-13.0	41.1	-91.2

LTE 2A –N5A – Antenna Vendor 1

30MHz to 26.5GHz – Tx Radiated Spurious LTE 2A- N5A – QPSK – Mid/Mid channel – 1880/836.5 MHz BW 20/20 MHz				
Frequency	RMS (EIRP)	Limit	Margin	Correction Factor
MHz	dBm	dBm	dB	
979.2	-46.3	-13.0	33.3	-62.1
1305.0	-43.2	-13.0	30.2	-63.3
2231.0	-38.1	-13.0	25.1	-60.5
28625.0	-37.2	-13.0	24.2	-59.2
9746.0	-48.0	-13.0	35.0	-85.6
15447.0	-59.1	-13.0	46.1	-90.9

LTE 48A –N66A – Antenna Vendor 1

30MHz to 40GHz – Tx Radiated Spurious LTE 48A- N66A – QPSK – Mid/High channel – 3625/1760 MHz BW 20/40 MHz				
Frequency	RMS (EIRP)	Limit	Margin	Correction Factor
MHz	dBm	dBm	dB	dB
104.7	-53.1	-40.0	13.1	-101.0
1879.5	-51.1	-40.0	11.1	-80.3
2187.0	-47.0	-40.0	7.0	-79.4
6237.8	-50.8	-40.0	10.8	-79.1
1879.5	-51.4	-40.0	11.4	-80.3
7249.5	-44.8	-40.0	4.8	-94.4
16000.0	-55.4	-40.0	15.4	-91.2
21749.0	-46.3	-40.0	6.3	-85.7

LTE 41A –N41A HPUE – Antenna Vendor 2

30MHz to 40GHz – Tx Radiated Spurious LTE 41A- N41A_HPUE – QPSK – Mid/High channel – 2593/2649.99 MHz BW 20/80 MHz				
Frequency	RMS (EIRP)	Limit	Margin	Correction Factor
MHz	dBm	dBm	dB	dB
101.9	-53.6	-25.0	28.6	-101.6
1832.5	-44.8	-25.0	19.8	-61.1
2177.5	-43.2	-25.0	18.2	-60.9
2899.0	-41.9	-25.0	16.9	-59.1
9724.0	-49.6	-25.0	24.6	-85.9
16000.0	-58.8	-25.0	33.8	-91.2

LTE 2A –N78A – Antenna Vendor 1

30MHz to 40GHz – Tx Radiated Spurious LTE 2A- N78A – QPSK – Mid/Mid channel – 1880/3750 MHz BW 20/50 MHz				
Frequency	RMS (EIRP)	Limit	Margin	Correction Factor
MHz	dBm	dBm	dB	dB
103.3	-53.2	-13.0	40.2	-101.2
2178.0	-47.6	-13.0	34.6	-79.6
5255.5	-51.7	-13.0	38.7	-81.8
6192.3	-50.6	-13.0	37.6	-79.3
7469.5	-53.6	-40.0	13.6	-93.7
37046.6	-54.1	-13.0	41.1	-80.3

B.2 Declared ERP / EIRP

	Band	Mode	WWAN Antenna	Tx Antenna	Conducted Power (dBm)	Antenna Gain (dBi)	ERP / EIRP (dBm)	ERP / EIRP (W)
WCDMA	WCDMA II	Notebook	Vendor 1	Ant 5	24.5	0.56	25.1	0.32
	WCDMA IV	Notebook	Vendor 1	Ant 5	24.5	0.41	24.9	0.31
	WCDMA V*	Notebook	Vendor 2	Ant 5	24.5	-1.33	23.2	0.21
LTE	LTE 2	Notebook	Vendor 1	Ant 5	24.0	0.56	24.6	0.29
	LTE 5	Notebook	Vendor 2	Ant 5	24.0	-1.33	22.7	0.18
	LTE 7	Notebook	Vendor 2	Ant 5	24.0	-0.43	23.6	0.23
	LTE12*	Notebook	Vendor 1	Ant 5	24.0	-0.31	23.7	0.23
	LTE 13*	Notebook	Vendor 1	Ant 5	24.0	-0.46	23.5	0.23
	LTE14*	Notebook	Vendor 1	Ant 5	24.0	-0.79	23.2	0.21
	LTE 25	Notebook	Vendor 1	Ant 5	24.0	0.56	24.6	0.29
	LTE 26*	Notebook	Vendor 2	Ant 5	24.0	-1.16	22.8	0.19
	LTE 30	Notebook	Vendor 2	Ant 5	23.0	2.05	25.1	0.32
	LTE 41-HPUE	Notebook	Vendor 2	Ant 8	27.0	1.50	28.5	0.71
	LTE 48	Notebook	Vendor 1	Ant 8	22.0	-0.21	21.8	0.15
	LTE 66	Notebook	Vendor 1	Ant 5	24.0	0.41	24.4	0.28
LTE 71	Notebook	Vendor 1	Ant 5	24.0	-1.17	22.8	0.19	
5G NR	N 2	Notebook	Vendor 1	Ant 5	24.0	0.56	24.6	0.29
	N 5*	Notebook	Vendor 2	Ant 5	24.0	-1.33	22.7	0.18
	N 7	Notebook	Vendor 2	Ant 5	24.0	-0.43	23.6	0.23
	N25	Notebook	Vendor 1	Ant 5	24.0	0.56	24.6	0.29
	N 30	Notebook	Vendor 2	Ant 5	23.0	2.05	25.1	0.32
	N 41-HPUE	Notebook	Vendor 2	Ant 8	27.0	1.50	28.5	0.71
	N 66	Notebook	Vendor 1	Ant 5	24.0	0.41	24.4	0.28
	N 77-HPUE	Notebook	Vendor 1	Ant 8	27.0	1.80	28.8	0.76
N 78	Notebook	Vendor 1	Ant 8	24.0	0.59	24.6	0.29	

* ERP values