



# TEST REPORT

EUT Description	<b>WWAN module installed on Notebook PC</b>
Brand Name	<b>HP</b>
Model Name	<b>HSN-I50C</b>
FCC ID	<b>B94HNI50CPT</b>
Date of Test Start/End	<b>2022-01-04 / 2022-01-31</b>
Features	<b>WWAN (LTE, UMTS), WLAN, BT</b> (see section 6)
Description	<b>HP HSN-I50C + WNC / HongBo antennas</b>

Applicant	<b>HP Inc.</b>
Address	<b>1501 Page Mill Road, Palo Alto CA 94304 USA</b>
Contact Person	<b>Sam Lin</b>
Telephone / Email	<b>+886 2 37896331 / sam.lin2@hp.com</b>

Reference Standards	<b>FCC 47 CFR Part §2.1093</b> (see section 1)	
RF Exposure Environment	<b>Portable devices - General population/uncontrolled exposure</b>	
Exposure Conditions	<b>Body worn</b>	
	SAR Result	SAR Limit
Maximum SAR Result & Limit	<b>1.18 W/kg (1g)</b>	<b>1.6 W/kg (1g)</b>
Min. test separation distance	<b>0mm to phantom, 9.4mm to antenna edge</b>	

Test Report identification	<b>211027-01.TR01</b>
Revision Control	<b>Rev. 02</b> <b>This test report revision replaces any previous test report revision</b> (See section 9)

The test results relate only to the samples tested.  
Reference to accreditation shall be used only by full reproduction of test report.

Issued by

Reviewed by

Edgar GARCIA  
(SAR Test Lead Engineer)

Cheiel IN  
(Technical Manager Deputy)

**Intel Corporation S.A.S – WRF Lab**  
**425 rue de Goa – Le Cargo B6 - 06600 Antibes, France**  
**Tel. +33493001400 / Fax +33493001401**

# Table of Contents

---

<b>1. Standards, reference documents and applicable test methods</b>	<b>4</b>
<b>2. General conditions, competences and guarantees</b>	<b>4</b>
<b>3. Preface</b>	<b>5</b>
<b>4. Environmental Conditions</b>	<b>6</b>
<b>5. Test samples</b>	<b>6</b>
<b>6. EUT Features</b>	<b>7</b>
<b>7. Remarks and comments</b>	<b>10</b>
<b>8. Test Verdicts summary</b>	<b>10</b>
<b>9. Document Revision History</b>	<b>10</b>
<b>Annex A. Test &amp; System Description</b>	<b>11</b>
A.1 SAR DEFINITION	11
A.2 SAR MEASUREMENT SYSTEM	12
A.2.1 SAR Measurement Setup	12
A.2.2 E-Field Measurement Probe	13
A.2.3 Flat Phantom	13
A.2.4 Device Positioner	14
A.3 DATA EVALUATION	15
A.4 SYSTEM AND LIQUID CHECK	17
A.4.1 System Check	17
A.4.2 Liquid Check	18
A.5 TEST EQUIPMENT LIST	19
A.5.1 SAR System #2	19
A.5.2 Shared Instrumentation	19
A.5.3 Tissue Simulant Liquid	20
A.6 MEASUREMENT UNCERTAINTY EVALUATION	20
A.7 RF EXPOSURE LIMITS	21
<b>Annex B. Test Results</b>	<b>22</b>
B.1 TEST CONDITIONS	22
B.1.1 Test SAR Test positions relative to the phantom	22
B.1.2 Test signal, Output power and Test Frequencies	23
B.1.3 Evaluation Exclusion and Test Reductions	24
B.2 CONDUCTED POWER MEASUREMENTS – TABLET MODE	26
B.2.1 WCDMA/ HSPA/ DC-HSPA	26
B.2.2 LTE	29
B.2.3 LTE UL Carrier Aggregation	48
B.3 TISSUE PARAMETERS MEASUREMENT	49
B.4 SYSTEM CHECK MEASUREMENTS	49
B.5 SAR TEST RESULTS	50
B.5.1 WCDMA	50
B.5.2 LTE	51
B.5.3 SAR Measurement Variability	55
B.5.4 Simultaneous Transmission SAR Evaluation	56
<b>Annex C. Test System Plots</b>	<b>58</b>
<b>Annex D. TSL Dielectric Parameters</b>	<b>81</b>
D.1 BODY 700MHZ-900MHZ SAR	81

D.2	BODY 1700MHZ-1950MHZ SAR .....	83
D.3	BODY 2300MHZ-2700MHZ .....	85
D.4	BODY 3500MHZ-3900MHZ .....	87
D.5	BODY 1700MHZ-2000MHZ .....	89
D.6	BODY 2300MHZ-2700MHZ .....	91
D.7	BODY 3500MHZ-3900MHZ .....	93
<b>Annex E.</b>	<b>Calibration Certificates .....</b>	<b>95</b>
<b>Annex F.</b>	<b>Photographs .....</b>	<b>97</b>
F.1	TEST SAMPLES .....	97
F.2	TEST POSITIONS.....	99
F.3	ANTENNA HOST PLATFORM LOCATION AND ADJACENT EDGE POSITIONS RELATIVE TO THE BODY .....	100
F.4	PHANTOM LIQUID LEVEL DURING MEASUREMENTS .....	101

## 1. Standards, reference documents and applicable test methods

FCC	<ol style="list-style-type: none"><li>1. FCC Title 47 CFR Part §2.1093 – Radiofrequency radiation exposure evaluation: portable devices. 2019-10-01 Edition</li><li>2. FCC OET KDB 447498 D01 v06 – RF Exposure Procedures and Equipment Authorization Policies for Mobile and Portable Devices.</li><li>3. FCC OET KDB 616217 D04 v01r02 – SAR Evaluation Considerations for Laptop, Notebook, Netbook and Tablet Computers.</li><li>4. FCC OET KDB 865664 D01 v01r04 – SAR Measurement Requirements for 100 MHz to 6 GHz.</li><li>5. FCC OET KDB 865664 D02 v01r02 – RF Exposure Compliance Reporting and Documentation Considerations.</li><li>6. FCC OET KDB 941225 D05 v02r05 – SAR Evaluation Considerations for LTE Devices.</li><li>7. FCC OET KDB 941225 D01 v03r01 – 3G SAR Measurement Procedures.</li><li>8. IEEE Std 1528-2013 – IEEE Recommended Practice Determining the Peak Spatial-Average Specific Absorption Rate (SAR) in the Human Head from Wireless Communication Devices: Measurement Techniques...</li><li>9. TCB Workshop Nov 2017 71-RF-Exposure-TCB-Slides-LTE UL/DL Carrier Aggregation SAR</li></ol>
-----	---

## 2. General conditions, competences and guarantees

- ✓ Tests performed under FCC standards identified in section 1 are covered by A2LA accreditation.
- ✓ Intel Corporation SAS Wireless RF Lab (Intel WRF Lab) is an ISO/IEC 17025:2017 laboratory accredited by the American Association for Laboratory Accreditation (A2LA) with the certificate number 3478.01.
- ✓ Intel Corporation SAS Wireless RF Lab (Intel WRF Lab) is an Accredited Test Firm recognized by the FCC, with Designation Number FR0011.
- ✓ Intel WRF Lab declines any responsibility with respect to the identified information provided by the customer and that may affect the validity of results.
- ✓ Intel WRF Lab only provides testing services and is committed to providing reliable, unbiased test results and interpretations.
- ✓ Intel WRF Lab is liable to the client for the maintenance of the confidentiality of all information related to the item under test and the results of the test.
- ✓ Intel WRF Lab has developed calibration and proficiency programs for its measurement equipment to ensure correlated and reliable results to its customers.
- ✓ This report is only referred to the item that has undergone the test.
- ✓ This report does not imply an approval of the product by the Certification Bodies or competent Authorities.

### 3. Preface

The HSN-I50C Laptop PC includes the Time Averaging SAR (TAS) concept. The TAS algorithm is implemented in the Intel XMM 7560R+ cellular modem, which is incorporated in the L860-GL-16 cellular module (FCC ID: ZMOL860GL16).

The implementation details and TAS operating characteristics are described in a separated document [1]. The validation of algorithm operations is performed by Intel Corporation according to the range of commonly used accessible control parameters used for typical host products. The validation results are reported in document [2].

The FCC SAR limit is a time averaged exposure metric. At host level, the normally required SAR test procedures are applicable for SAR compliance testing at upper-threshold values of the algorithm, which is the maximum output power level for continuous time-averaging operations TAS algorithm enforces. The reliability of this has been demonstrated by results in the Algorithm Validation Test Report [2].

The model supports simultaneous transmission of WWAN, BT and WLAN. The TAS algorithm is only applied to WWAN cellular module. The WLAN / BT SAR evaluation is presented in the document [3].

The SAR evaluation of WWAN is performed in this report as well as the RF exposure assessment for simultaneous transmission of WWAN, WLAN and BT.

[1] 210305\_TAS\_Operational\_Report\_XMM7560\_R+\_Rev01

[2] 210104-03.TR01 - TAS\_Validation\_Report\_Rev01

#### 4. Environmental Conditions

- ✓ At the site where the measurements were performed the following limits were not exceeded during the tests:

Temperature	22.8°C ± 2°C
Humidity	44.5% ± 20%
Liquid Temperature	21°C ± 2°C

#### 5. Test samples

Sample	Control #	Description	Model	Serial #	Date of receipt	Note
#01	211027-01.S02	WWAN module installed on Notebook PC	HSN-I50C	0001760GWR	2022-01-04	WNC Antenna
#02	211027-01.S08	WWAN module installed on Notebook PC	HSN-I50C	0001760GOC	2022-01-04	HongBo Antenna

Both samples used the same conducted power measurements as the same WWAN module was used on them during SAR testing.

## 6. EUT Features

The herein information is provided by the customer.

Intel WRF Lab declines any responsibility for the accuracy of the stated customer provided information, especially if it has any impact on the correctness of test results presented in this report.

Brand Name	HP
Model Name	HSN-I50C
Prototype / Production	Production
Host Identification	HSN-I50C

### Supported radios

#### WWAN:

Mode	Bands	Supported Tx Mode			
		RMC	HSDPA	HSUPA	DC-HSDPA
WCDMA	FDD II (1850.0 – 1910.0 MHz)	✓	✓	✓	✓
	FDD IV (1710.0 – 1755.0 MHz)	✓	✓	✓	✓
	FDD V (824.0 – 849.0 MHz)	✓	✓	✓	✓

FDD/TDD	Bands	Modulations	Bandwidth					
			1.4	3	5	10	15	20
LTE FDD	Band 2 (1850.0 – 1910.0 MHz)	QPSK/16QAM/64QAM/256QAM	✓	✓	✓	✓	✓	✓
	Band 4 (1710.0 – 1755.0 MHz)	QPSK/16QAM/64QAM/256QAM	✓	✓	✓	✓	✓	✓
	Band 5 (824.0 – 849.0 MHz)	QPSK/16QAM/64QAM/256QAM	✓	✓	✓	✓		
	Band 7 (2500.0 – 2570.0 MHz)	QPSK/16QAM/64QAM/256QAM			✓	✓	✓	✓
	Band 12 (699.0 – 716.0 MHz)	QPSK/16QAM/64QAM/256QAM	✓	✓	✓	✓		
	Band 13 (777.0 – 787.0 MHz)	QPSK/16QAM/64QAM/256QAM			✓	✓		
	Band 14 (788.0 – 798.0 MHz)	QPSK/16QAM/64QAM/256QAM			✓	✓		
	Band 17 (704.0 – 716.0 MHz)	QPSK/16QAM/64QAM/256QAM			✓	✓		
	Band 25 (1850.0 – 1915.0 MHz)	QPSK/16QAM/64QAM/256QAM	✓	✓	✓	✓	✓	✓
	Band 26 (814.0 – 849.0 MHz)	QPSK/16QAM/64QAM/256QAM	✓	✓	✓	✓	✓	
	Band 30 (2305.0 – 2315.0 MHz)	QPSK/16QAM/64QAM/256QAM			✓	✓		
LTE TDD	Band 66 (1710.0 – 1780.0 MHz)	QPSK/16QAM/64QAM/256QAM	✓	✓	✓	✓	✓	✓
	Band 38 (2570.0 – 2620.0 MHz)	QPSK/16QAM/64QAM/256QAM			✓	✓	✓	✓
	Band 41 (2496.0 – 2690.0 MHz)	QPSK/16QAM/64QAM/256QAM			✓	✓	✓	✓
	Band 48 (3550.0 – 3700.0 MHz)	QPSK/16QAM/64QAM/256QAM			✓	✓	✓	✓

UL carrier aggregation LTE (Intra-band)	
	FDD Band 5B
	FDD Band 38C
	FDD Band 41C
	FDD Band 66B
	FDD Band 66C

#### WLAN

Mode	UL Freq Range
802.11b/g/n/ax	2.4GHz (2400.0 – 2483.5 MHz)
802.11a/n/ac/ax	5.2GHz (5150.0 – 5250.0 MHz)
	5.3GHz (5250.0 – 5350.0 MHz)
	5.6GHz (5470.0 – 5725.0 MHz)
	5.8GHz (5725.0 – 5875.0 MHz)
802.11ax	6.0GHz (5925.0 – 7250.0 MHz)
Bluetooth v5.2 & BLE	2.4GHz (2400.0 – 2483.5 MHz)

Antenna Information “information provided by the applicant”

**The DUTs have 1 WWAN TX antenna:**

Transmitter	Ant5 (Tx/Rx)	Ant5 (Tx/Rx)
Manufacturer	WNC	HongBo
Antenna type	PIFA antenna	PIFA antenna
Part number	6036B0303501 (81EABL15.G31)	6036B0305001 (00-2602748450)

Simultaneous Transmission Configurations

WWAN Main (Ant5) + WLAN 2.4GHz Main + BT Aux  
 WWAN Main (Ant5) + WLAN 2.4GHz Main + WLAN 2.4GHz Aux  
 WWAN Main (Ant5) + WLAN 5GHz Main + BT Aux  
 WWAN Main (Ant5) + WLAN 5GHz Main + WLAN 5GHz Aux  
 WWAN Main (Ant5) + WLAN 5GHz Main + WLAN 5GHz Aux + BT Aux  
 WWAN Main (Ant5) + WLAN 6GHz Main + BT Aux  
 WWAN Main (Ant5) + WLAN 6GHz Main + WLAN 6GHz Aux  
 WWAN Main (Ant5) + WLAN 6GHz Main + WLAN 6GHz Aux + BT Aux

WLAN transmitter is considered in this report just for the simultaneous transmission evaluation with the WWAN module (See section B.5.6)

Additional information

- 5.60-5.65 GHz band (TDWR) is supported by the device
- Band gap is supported by the device
- One power settings is implemented in the DUT:
  - Max power for Notebook mode
- Maximum Power Reduction (MPR) is implemented according to 3GPP, built-in by design on the tune-up power:

Modulation	Channel bandwidth / #RB						MPR (dB)
	1.4 MHz	3.0 MHz	5 MHz	10 MHz	15 MHz	20 MHz	
QPSK	> 5	> 4	> 8	> 12	> 16	> 18	≤ 1
16 QAM	≤ 5	≤ 4	≤ 8	≤ 12	≤ 16	≤ 18	≤ 1
16 QAM	> 5	> 4	> 8	> 12	> 16	> 18	≤ 2
64 QAM	≤ 5	≤ 4	≤ 8	≤ 12	≤ 16	≥ 18	≤ 2
64 QAM	> 5	> 4	> 8	> 12	> 16	> 18	≤ 3
256 QAM	≥ 1						≤ 5

A-MPR (additional MPR) was disabled during SAR testing



The following table indicates the power levels and tolerance for tablet mode:

**Maximum Output power specification + Tune up tolerance**

Mode	Tx Ant	Technology	Bands	Class	Nominal (dBm)	Tolerance dB	Lower Tolerance (dBm)	Upper Tolerance (dBm)
Laptop	5	WCDMA/HSPA	FDD II (1850.0 – 1910.0 MHz)	3	16.5	±1	15.5	17.5
	5	WCDMA/HSPA	FDD IV (1710.0 – 1755.0 MHz)	3	16.5	±1	15.5	17.5
	5	WCDMA/HSPA	FDD V (824.0 – 849.0 MHz)	3	20.5	±1	19.5	21.5
	5	LTE	B2 (1850.0 – 1910.0 MHz)	3	16.5	±1	15.5	17.5
	5	LTE	B4 (1710.0 – 1755.0 MHz)	3	16.5	±1	15.5	17.5
	5	LTE	B5 (824.0 – 849.0 MHz)	3	20.5	±1	19.5	21.5
	5	LTE	B7 (2500.0 – 2570.0 MHz)	3	15.0	±1	14.0	16.0
	5	LTE	B12 (699.0 – 716.0 MHz)	3	21.0	±1	20.0	22.0
	5	LTE	B13 (777.0 – 787.0 MHz)	3	21.0	±1	20.0	22.0
	5	LTE	B14 (788.0 – 798.0 MHz)	3	20.5	±1	19.5	21.5
	5	LTE	B17 (704.0 – 716.0 MHz)	3	21.0	±1	20.0	22.0
	5	LTE	B25 (1850.0 – 1915.0 MHz)	3	16.5	±1	15.5	17.5
	5	LTE	B26 (814.0 – 849.0 MHz)	3	20.5	±1	19.5	21.5
	5	LTE	B30 (2305.0 – 2315.0 MHz)	3	16.5	±1	15.5	17.5
	5	LTE	B38 (2570.0 – 2620.0 MHz)	3	15.0	±1	14.0	16.0
	5	LTE	B41 (2496.0 – 2690.0 MHz)	3	15.0	±1	14.0	16.0
	5	LTE	B41-HPUE (2496.0 – 2690.0 MHz)	2	15.0	±1	14.0	16.0
	5	LTE	B48 (3550.0 – 3700.0 MHz)	3	17.0	±1	16.0	18.0
5	LTE	B66 (1710.0 – 1780.0 MHz)	3	16.5	±1	15.5	17.5	

As mentioned in Section 3, the SAR compliance testing is performed at upper-threshold values of the algorithm, which is the maximum output power level for continuous time-averaging operations TAS algorithm enforces.

In TAS operation, the control parameters including the upper-threshold value are stored in NVM. They are inaccessible to the normal users and no other interface is available for changing these control parameters.

The table below shows the upper-threshold values used as continuous power for SAR testing as well as the different TAS parameters defined in [1] and [2] of section 3, to be embedded in the host:

Mode	Tx Ant.	Technology	Bands	Class	Nominal Full Power (dBm)	Upper Threshold (dBm)	Lower Threshold (dBm)	DPR_ON Power (dBm)
Laptop	5	WCDMA/HSPA	FDD II (1850.0 – 1910.0 MHz)	3	23.5	18.5	17.5	16.5
	5	WCDMA/HSPA	FDD IV (1710.0 – 1755.0 MHz)	3	23.5	18.5	17.5	16.5
	5	WCDMA/HSPA	FDD V (824.0 – 849.0 MHz)	3	23.5	22.5	21.5	20.5
	5	LTE	B2 (1850.0 – 1910.0 MHz)	3	23.0	18.5	17.5	16.5
	5	LTE	B4 (1710.0 – 1755.0 MHz)	3	23.0	18.5	17.5	16.5
	5	LTE	B5 (824.0 – 849.0 MHz)	3	23.0	22.5	21.5	20.5
	5	LTE	B7 (2500.0 – 2570.0 MHz)	3	23.0	17.0	16.0	15.0
	5	LTE	B12 (699.0 – 716.0 MHz)	3	23.0	23.0	22.0	21.0
	5	LTE	B13 (777.0 – 787.0 MHz)	3	23.0	23.0	22.0	21.0
	5	LTE	B14 (788.0 – 798.0 MHz)	3	23.0	22.5	21.5	20.5
	5	LTE	B17 (704.0 – 716.0 MHz)	3	23.0	23.0	22.0	21.0
	5	LTE	B25 (1850.0 – 1915.0 MHz)	3	23.0	18.5	17.5	16.5
	5	LTE	B26 (814.0 – 849.0 MHz)	3	23.0	22.5	21.5	20.5
	5	LTE	B30 (2305.0 – 2315.0 MHz)	3	23.0	18.5	17.5	16.5
	5	LTE	B38 (2570.0 – 2620.0 MHz)	3	23.0	17.0	16.0	15.0
	5	LTE	B41 (2496.0 – 2690.0 MHz)	3	23.0	17.0	16.0	15.0
	5	LTE	B41-HPUE(2496.0 – 2690.0 MHz)	2	23.0	17.0	16.0	15.0
	5	LTE	B48 (3550.0 – 3700.0 MHz)	3	21.0	19.0	18.0	17.0
5	LTE	B66 (1710.0 – 1780.0 MHz)	3	23.0	18.5	17.5	16.5	

SAR compliance is demonstrated with the *Reported SAR*:

$$\text{Reported SAR} = \text{measured } 1\text{gSAR @ Reported Upper Threshold} < \text{FCC SAR limit}$$

Where, *Reported Upper Threshold* = *Upper Threshold (stored in NVM) + Tolerance*

### 7. Remarks and comments

1. Only the plots for the test positions with the highest measured SAR per band/mode are included in Annex C as required per FCC OET KDB 865664 D02, paragraph 2.3.h.
2. The same conducted power measurements were used on both samples since the same WWAN module has been used on the samples under test during SAR measurements.

### 8. Test Verdicts summary

The statement of conformity to applicable standards in the table below are based on the measured values, without taking into account the measurement uncertainties.

Mode	Band (UL)	Highest Reported SAR (1g) (W/kg)	Verdict
WCDMA	FDD II (1850.0 – 1910.0 MHz)	0.69	P
	FDD IV (1710.0 – 1755.0 MHz)	0.73	P
	FDD V (824.0 – 849.0 MHz)	0.93	P
LTE FDD	Band 2 (1850.0 – 1910.0 MHz)	NM	NA
	Band 4 (1710.0 – 1755.0 MHz)	NM	NA
	Band 5 (824.0 – 849.0 MHz)	NM	NA
	Band 7 (2500.0 – 2570.0 MHz)	0.64	P
	Band 12 (699.0 – 716.0 MHz)	1.10	P
	Band 13 (777.0 – 787.0 MHz)	0.93	P
	Band 14 (788.0 – 798.0 MHz)	0.89	P
	Band 17 (704.0 – 716.0 MHz)	NM	NA
	Band 25 (1850.0 – 1915.0 MHz)	0.74	P
	Band 26 (814.0 – 849.0 MHz)	1.00	P
	Band 30 (2305.0 – 2315.0 MHz)	0.87	P
LTE TDD	Band 66 (1710.0 – 1780.0 MHz)	1.18	P
	Band 38 (2570.0 – 2620.0 MHz)	NM	NA
	Band 41 (2496.0 – 2690.0 MHz)	0.42	P
	Band 48 (3550.0 – 3700.0 MHz)	0.55	P

P: Pass  
 F: Fail  
 NM: Not Measured  
 NA: Not Applicable

According to the FCC OET KDB 690783 D01, this is the summary of the values for the Grant Listing:

Highest Reported SAR (1g) (W/kg)				
Exposure Condition	Equipment Class			
	PCE	DTS	DSS	U-NII
Body Worn	1.18	0.40	0.40	0.40
Simultaneous Tx	Sum-SAR: 1.58	Sum-SAR: 1.58	Sum-SAR: 1.58	Sum-SAR: 1.58

Considering the results of the performed test according to FCC 47CFR Part 2.1093 the item under test is IN COMPLIANCE with the requested specifications specified in Section1. Standards, reference documents and applicable test methods

### 9. Document Revision History

Revision #	Modified by	Revision Details
Rev. 00	E. Garcia	First Issue
Rev. 01	E. Garcia	Corrected modem name L680-GL-16 Corrected contact, telephone and e-mail
Rev. 02	E. Garcia	Corrected SAR results for WCDMA II & IV

# Annex A. Test & System Description

---

## A.1 SAR Definition

Specific Absorption rate is defined as the time derivative of the incremental energy (dW) absorbed by (dissipated in) and incremental mass (dm) contained in a volume element (dV) of a given density ( $\rho$ ).

$$SAR = \frac{d}{dt} \cdot \left( \frac{dW}{dm} \right) = \frac{d}{dt} \cdot \left( \frac{dW}{\rho \cdot dV} \right)$$

SAR is expressed in units of watts per kilogram (W/kg). SAR can be related to the electric field at a point by

$$SAR = \frac{\sigma |E|^2}{\rho}$$

Where:

$\sigma$  = Conductivity of the tissue (S/m)

$\rho$  = Mass density of the tissue (kg/m<sup>3</sup>)

E = RMS electric field strength (V/m)

## A.2 SAR Measurement System

### A.2.1 SAR Measurement Setup

The DASY6 system for performing compliance tests consists of the following items:

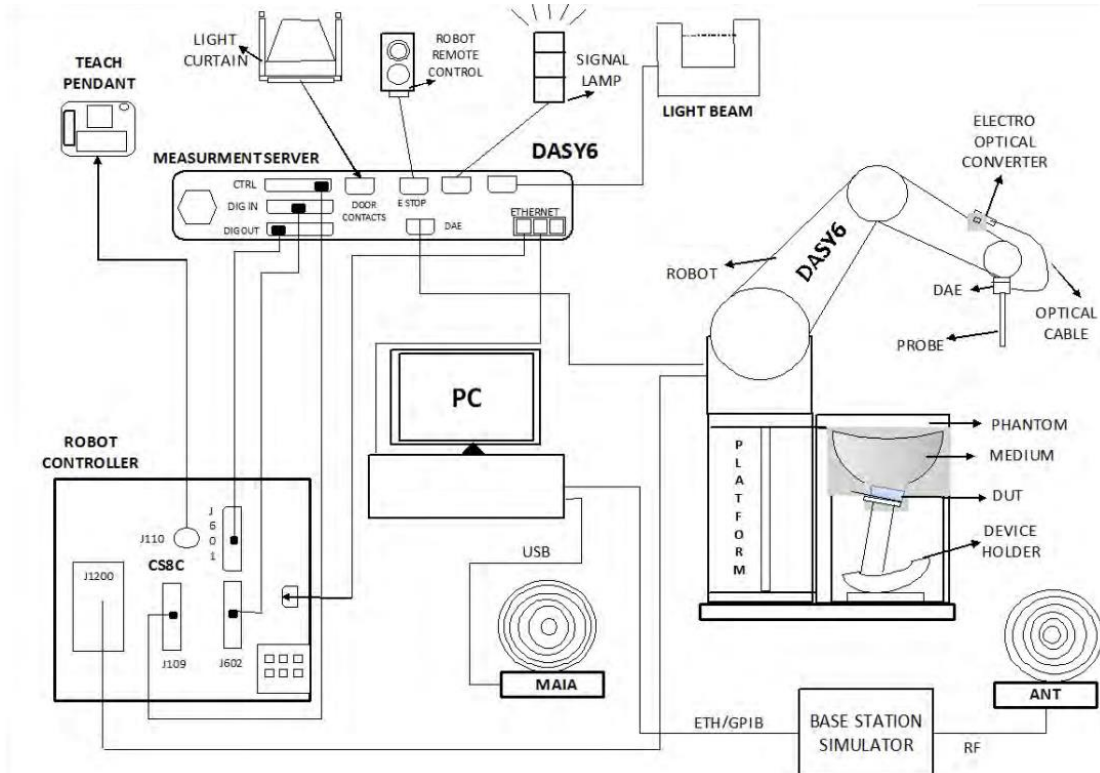

- ✓ A standard high precision 6-axis robot (Stäubli TX/RX family) with controller, teach pendant and software. It includes an arm extension for accommodating the data acquisition electronics (DAE)
- ✓ An isotropic field probe optimized and calibrated for the targeted measurements.
- ✓ A data acquisition electronics (DAE) which performs the signal amplification, signal multiplexing, AD-conversion, offset measurements, mechanical surface detection, collision detection, etc. The unit is battery powered with standard or rechargeable batteries. The signal is optically transmitted to the EOC.
- ✓ The Electro-optical Converter (EOC) performs the conversion from optical to electrical signals for the digital communication to the DAE. The EOC signal is transmitted to the measurement server.
- ✓ The function of the measurement server is to perform the time critical tasks such as signal filtering, control of the robot operation and fast movements interrupts.
- ✓ The Light Beam used is for probe alignment. This improves the (absolute) accuracy of the probe positioning.
- ✓ A computer running Win7 professional operating system and the DASY6 software.
- ✓ Remote control and teach pendant as well as additional circuitry for robot safety such as warning lamps, etc.
- ✓ The phantom, the device holder and other accessories according to the targeted measurement.
- ✓ MAIA is a hardware interface (Antenna) used to evaluate the modulation and audio interference characteristics of RF signals.
- ✓ ANT is an ultra-wideband antenna for use with the base station simulators over 698 MHz to 6GHz.
- ✓ The base station simulator is an equipment used for SAR cellular tests in order to emulate the cellular signals characteristics and behavior between a regular base station and the equipment under test.
- ✓ Tissue simulating liquid.
- ✓ System Validation dipoles.
- ✓ Network emulator.

### A.2.2 E-Field Measurement Probe

The probe is constructed using three orthogonal dipole sensors arranged on an interlocking, triangular prism core. The probe has built-in shielding against static charges and is contained within a PEEK cylindrical enclosure material at the tip.



The probe's characteristics are:

Frequency Range	30MHz – 6GHz
Length	337 mm
Probe tip external diameter	2.5 mm
Typical distance between dipoles and the probe tip	1 mm
Axial Isotropy (in human-equivalent liquids)	±0.3 dB
Hemispherical Isotropy (in human-equivalent liquids)	±0.5 dB
Linearity	±0.2 dB
Maximum operating SAR	100 W/kg
Lower SAR detection threshold	0.001 W/kg

### A.2.3 Flat Phantom

Phantom for compliance testing of handheld and body-mounted wireless devices in the frequency range of 30 MHz to 6 GHz. ELI is fully compatible with the IEC 62209-2 standard and all known tissue simulating liquids. ELI has been optimized regarding its performance and can be integrated into our standard phantom tables. A cover prevents evaporation of the liquid. Reference markings on the phantom allow installation of the complete setup, including all predefined phantom positions and measurement grids, by teaching three points. The phantom is compatible with all SPEAG dosimetric probes and dipoles.

The phantom's characteristics are:

Material	Vinylester, glass fiber reinforced (VE-GF)
Shell thickness	2 mm ± 0.2 mm
Filling volume	30 Liters approx.
Dimensions	Major axis: 600mm / Minor axis: 400mm

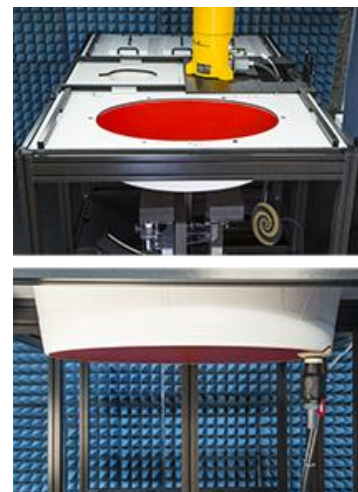

### A.2.4 Device Positioner

The SAR in the phantom is approximately inversely proportional to the square of the distance between the source and the liquid surface. For a source at 5 mm distance, a positioning uncertainty of 0.5 mm would produce a SAR uncertainty of 20%. Accurate device positioning is therefore crucial for accurate and repeatable measurements. The positions in which the devices must be measured are defined by the standards.



The DASY device holder is designed to cope with the different positions given in the standard. It has two scales for device rotation (with respect to the body axis) and device inclination (with respect to the line between the ear reference points). The rotation center for both scales is the ear reference point (ERP). Thus the device needs no repositioning when changing the angles.

The DASY device holder is constructed of low-loss POM material having the following dielectric parameters: relative permittivity  $\epsilon=3$  and loss tangent  $\delta=0.02$ . The amount of dielectric material has been reduced in the closest vicinity of the device, since measurements have suggested that the influence of the clamp on the test results could thus be lowered.

A simple but effective and easy-to-use extension for the Mounting Device; facilitates testing of larger devices according to IEC 62209-2 (e.g., laptops, cameras, etc.); lightweight and fits easily on the upper part of the Mounting Device in place of the phone positioner. The extension is fully compatible with the Twin SAM, ELI and other Flat Phantoms.



### A.3 Data Evaluation

- **Power Reference measurement**

The robot measures the E field in a specified reference position that can be either the selected section's grid reference point or a user point in this section at 4mm of the inner surface of the phantom, 2mm for frequencies above 3GHz.

- **Area Scan**

Measurement procedures for evaluating SAR from wireless handsets typically start with a coarse measurement grid to determine the approximate location of the local peak SAR values. This is known as the area-scan procedure. The SAR distribution is scanned along the inside surface of one side of the phantom head, at least for an area larger than the projection of the handset and antenna. The distance between the measured points and phantom surface should be less than 8 mm, and should remain constant (with variation less than  $\pm 1$  mm) during the entire scan in order to determine the locations of the local peak SAR with sufficient accuracy. The angle between the probe axis and the surface normal line is recommended but not required to be less than  $30^\circ$ . If this angle is larger than  $30^\circ$  and the closest point on the probe-tip housing to the phantom surface is closer than a probe diameter, the boundary effect may become larger and polarization dependent. This additional uncertainty needs to be analyzed and accounted for. To achieve this, modified test procedures and additional uncertainty analyses not described in this recommended practice may be required. The measurement and interpolation point spacing should be chosen such as to allow identification of the local peak locations to within one-half of the linear dimension of a side of the zoom-scan volume. Because a local peak having specific amplitude and steep gradients may produce a lower peak spatial-average SAR compared to peaks with slightly lower amplitude and less steep gradients, it is necessary to evaluate these other peaks as well. However, since the spatial gradients of local SAR peaks are a function of the wavelength inside the tissue-equivalent liquid and the incident magnetic field strength, it is not necessary to evaluate local peaks that are less than 2 dB or more below the global maximum peak. Two-dimensional spline algorithms (Brishoual et al. 2001; Press et al., 1996) are typically used to determine the peaks and gradients within the scanned area. If a peak is found at a distance from the scan border of less than one-half the edge dimension of the desired 1 g or 10 g cube, the measurement area should be enlarged if possible.

- **Zoom Scan**

To evaluate the peak spatial-average SAR values for 1 g or 10 g cubes, fine resolution volume scans, called zoom scans, are performed at the peak SAR locations identified during the area scan. The minimum zoom scan volume size should extend at least 1.5 times the edge dimension of a 1 g cube in all directions from the center of the scan volume, for both 1 g and 10 g peak spatial-average SAR evaluations. Along the phantom curved surfaces, the front face of the volume facing the tissue/liquid interface conforms to the curved boundary, to ensure that all SAR peaks are captured. The back face should be equally distorted to maintain the correct averaging mass. The flatness and orientation of the four side faces are unchanged from that of a cube whose orientation is within  $\pm 30^\circ$  of the line normal to the phantom at the center of the cube face next to the phantom surface. The peak local SAR locations that were determined in the area scan (interpolated values) should be used for the centers of the zoom scans. If a scan volume cannot be centered due to proximity of a phantom shape feature, the probe should be tilted to allow scan volume enlargement. If probe tilt is not feasible, the zoom-scan origin may be shifted, but not by more than half of the 1 g or 10 g cube edge dimension.

After the zoom-scan measurement, extrapolations from the closest measured points to the surface, for example along lines parallel to the zoom-scan centerline, and interpolations to a finer resolution between all measured and extrapolated points are performed. Extrapolation algorithm considerations are described in 6.5.3, and 3-D spline methods (Brishoual et al., 2001; Kreyszig, 1983; Press et al., 1996) can be used for interpolation. The peak spatial-average SAR is finally determined by a numerical averaging of the local SAR values in the interpolation grid, using for example a trapezoidal algorithm for the integration (averaging).

In some areas of the phantom, such as the jaw and upper head regions, the angle of the probe with respect to the line normal to the surface may be relatively large, e.g., greater than  $\pm 30^\circ$ , which could increase the boundary effect error to a larger level. In these cases, during the zoom scan a change in the orientation of the probe, the phantom, or both is recommended but not required for the duration of the zoom scan, so that the angle between the probe axis and the line normal to the surface is within  $30^\circ$  for all measurement points.



- **Power Drift measurement**

The robot re-measures the E-Field in the same reference location measured at the Power Reference. The drift measurement gives the field difference in dB from the first to the last reference reading. This allows a user to monitor the power drift of the device under test that must remain within a maximum variation of  $\pm 5\%$ .

- **Post-processing**

The procedure for spatial peak SAR evaluation has been implemented according to the IEEE1528 and IEC 62209-1/2 standards. It can be conducted for 1g and 10g.

The software allows evaluations that combine measured data and robot positions, such as:

- ✓ Maximum search
- ✓ Extrapolation
- ✓ Boundary correction
- ✓ Peak search for averaged SAR

Interpolation between the measured points is performed when the resolution of the grid is not fine enough to compute the average SAR over a given mass.

Extrapolation routines are used to obtain SAR values between the lowest measurement points and the inner phantom surface. The extrapolation is determined by the surface detection distance and the probe sensor offset. Several measurements at different distances are necessary for the extrapolation.



## A.4 System and Liquid Check

### A.4.1 System Check

The system performance check verifies that the system operates within its specifications. System and operator errors can be detected and corrected. It is recommended that the system performance check be performed prior to any usage of the system in order to guarantee reproducible results.

The system performance check uses normal SAR measurements in a simplified setup with a well characterized source. This setup was selected to give a high sensitivity to all parameters that might fail or vary over time. The system check does not intend to replace the calibration of the components, but indicates situations where the system uncertainty is exceeded due to drift or failure.

In the simplified setup for system check, the EUT is replaced by a calibrated dipole and the power source is replaced by a controlled continuous wave generated by a signal generator. The calibrated dipole must be placed beneath the flat phantom section of the phantom at the correct distance.

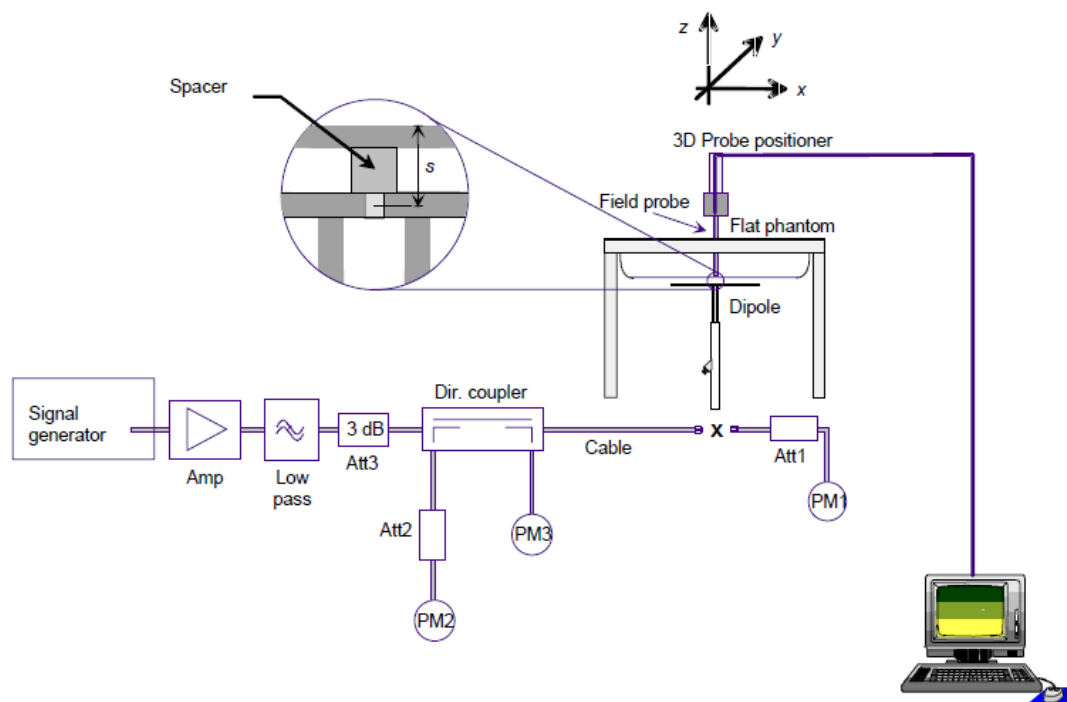

The equipment setup is shown below:

- ✓ Signal Generator
- ✓ Amplifier
- ✓ Directional coupler
- ✓ Power meter
- ✓ Calibrated dipole

First, the power meter PM1 (including attenuator Att1) is connected to the cable to measure the forward power at the location of the connector (x) to the system check source. The signal generator is adjusted for the desired forward power at the connector as read by power meter PM1 after attenuation Att1 and also as coupled through Att2 to PM2. After connecting the cable to the source, the signal generator is readjusted for the same reading at power meter PM2.

SAR results are normalized to a forward power of 1W to compare the values with the calibration reports results as described at IEEE 1528 and IEC 62209 standards.

#### A.4.2 Liquid Check

The dielectric parameters check is done prior to the use of the tissue simulating liquid. The verification is made by comparing the relative permittivity and conductivity to the values recommended by the applicable standards.

The liquid verification was performed using the following test setup:

- ✓ VNA (Vector Network Analyzer)
- ✓ Open-Short-Load calibration kit
- ✓ RF Cable
- ✓ Open-Ended Coaxial probe
- ✓ DAK software tool
- ✓ SAR Liquid
- ✓ De-ionized water
- ✓ Thermometer

These are the target dielectric properties of the tissue-equivalent liquid material as defined in FCC OET KDB 865664 D01.

Frequency (MHz)	Body SAR	
	$\epsilon_r$ (F/m)	$\sigma$ (S/m)
150	61.9	0.80
300	58.2	0.92
450	56.7	0.94
835	55.2	0.97
900	55.0	1.05
1450	54.0	1.30
1800-2000	53.3	1.52
2450	52.7	1.95
3000	52.0	2.73
5800	48.2	6.00

( $\epsilon_r$  = relative permittivity,  $\sigma$  = conductivity and  $\rho$  = 1000 kg/m<sup>3</sup>)

The measurement system implement a SAR error compensation algorithm as documented in IEEE Std 1528-2013 (equivalent to draft standard IEEE P1528-2011) to automatically compensate the measured SAR results for deviations between the measured and required tissue dielectric parameters (applied to only scale up the measured SAR, and not downward) so, according to FCC OET KDB 865664 D01, the tolerance for  $\epsilon_r$  and  $\sigma$  may be relaxed to  $\pm 10\%$ .

## A.5 Test Equipment List

### A.5.1 SAR System #2

ID #	Device	Type/Model	Serial Number	Manufacturer	Cal. Date	Cal. Due Date
002-008	Data Acquisition Electronics	DAE4	1429	SPEAG	2021-05-11	2022-05-11
002-009	Dosimetric E-Field probe	EX3DV4	3978	SPEAG	2021-05-22	2022-05-22
002-000	6-axis Robot	TX60 L	F16/55FXA1/A/01	STAÜBLI	n/a	n/a
002-001	Robot Controller	CS8C	F16/55FXA1/C/01	STAÜBLI	n/a	n/a
002-002	Measurement Server	DASY6 P/N: SE UMS 028 BB	1489	SPEAG	n/a	n/a
002-003	Electro-Optical Converter	EOC60	1098	SPEAG	n/a	n/a
002-004	Light Beam Unit	SE UKS 030 AA	-	Di-soric	n/a	n/a
002-005	Oval Flat Phantom	ELI v8.0	2048	SPEAG	n/a	n/a
002-007	Measurement SW	DASY v6.14	9-5DEE27C2	SPEAG	n/a	n/a
002-006	Laptop Holder	P/N SM LH1 001 CD	-	SPEAG	n/a	n/a

### A.5.2 Shared Instrumentation

ID #	Device	Type/Model	Serial Number	Manufacturer	Cal. Date	Cal. Due Date
123-000	USB Power Sensor	NRP-Z81	102278	R&S	2021-04-13	2023-04-13
124-000	USB Power Sensor	NRP-Z81	102279	R&S	2021-04-13	2023-04-13
135-000	Network Emulator	CMW500	152721	R&S	2020-03-26	2022-03-26
126-000	Vector Signal Generator	ESG E4438C	MY45092885	Agilent	2021-05-27	2023-05-27
099-000	Liquid measurement SW	DAK-3.5 V2.6.0.5	9-2687B491	SPEAG	n/a	n/a
339-000	Vector Network Analyzer	ZNB 40	101740	R&S	2020-07-10	2022-07-10
071-000	System Validation Dipole 750MHz	D750V3	1136	SPEAG	2021-01-21	2023-01-21
072-000	System Validation Dipole 835MHz	D835V2	4d192	SPEAG	2021-01-21	2023-01-21
073-000	1750 MHz System Validation Dipole	D1750V2	1133	SPEAG	2021-01-14	2023-01-14
074-000	1900 MHz System Validation Dipole	D1900V2	5d197	SPEAG	2021-01-14	2023-01-14
075-000	2300 MHz System Validation Dipole	D2300V2	1046	SPEAG	2021-01-13	2023-01-13
076-000	2600 MHz System Validation Dipole	D2600V2	1100	SPEAG	2021-01-13	2023-01-13
404-000	3700 MHz System Validation Dipole	D3700V2	1093	SPEAG	2021-05-21	2023-05-21
327-000	Temperature & Humidity Logger	RA32E-TH1-RAS	RA32-F0DED9	AVTECH	2021-03-09	2023-03-09
398-000	Thermometer	922	33622932/208	Testo	2021-11-09	2023-11-19
198-000	0.8-21GHz RF amplifier	TVA-82-213A	2004003	Mini-Circuits	2021-08-13	2022-02-13
078-000	RF Cable	ST-18/SMAm/SMAm/48	1158830	Huber & Suhner	2021-08-13	2022-02-13
079-000	RF Cable	ST-18/SMAm/SMAm/48	1158831	Huber & Suhner	2021-08-13	2022-02-13
077-000	Coupler	CD0.5-8-20-30	1251-002	Amd-group	2021-08-13	2022-02-13

### A.5.3 Tissue Simulant Liquid

TSL	Manufacturer / Model	Freq Range (MHz)	Main Ingredients
Body WideBand	SPEAG MBBL600-6000V6 Batch 160603-01	600-6000	Ethenediol, Sodium petroleum sulfonate, Hexylene Glycol / 2-Methyl-pentane-2.4-diol, Alkoxyated alcohol

### A.6 Measurement Uncertainty Evaluation

The system uncertainty evaluation is shown in the table below with a coverage factor of  $k = 2$  to indicate a 95% level of confidence:

SPEAG DASY6 Uncertainty Budget According to IEC/IEEE 62209-1528 (4 MHz - 6 GHz) including IEEE 1528-2013 and IEC 62209-1/2016, IEC 62209-2/2010								
Symbol	Error Description	Uncert. Value	Prob. Dist.	Div.	(ci) 1g	(ci) 10g	Std Unc. (1g)	Std Unc. (10g)
<b>Measurement System Errors</b>								
CF	Probe Calibration	±14.0 %	N	2	1	1	±7.0 %	±7.0 %
CF <sub>drift</sub>	Probe Calibration Drift	±1.0 %	N	1	1	1	±1.0 %	±1.0 %
LIN	Probe Linearity	±4.7 %	R	√3	1	1	±2.7 %	±2.7 %
BBS	Broadband Signal	±3.0 %	N	2	1	1	±1.5 %	±1.5 %
ISO	Axial Isotropy	±4.7 %	R	√3	0.5	0.5	±1.4 %	±1.4 %
ISO	Hemispherical Isotropy	±9.6 %	R	√3	0.5	0.5	±2.8 %	±2.8 %
DAE	Data Acquisition	±0.3 %	N	1	1	1	±0.3 %	±0.3 %
AMB	RF Ambient	±1.8 %	N	1	1	1	±1.8 %	±1.8 %
Δ <sub>sys</sub>	Probe Positioning	±0.2 %	N	1	0.33	0.33	±0.1 %	±0.1 %
DAT	Data Processing	±2.3 %	N	1	1	1	±2.3 %	±2.3 %
<b>Phantom and Device Errors</b>								
LIQ(σ)	Conductivity (meas.) <sub>DAK</sub>	±2.5 %	N	1	0.78	0.71	±2.0 %	±1.8 %
LIQ(Tσ)	Conductivity (temp.) <sub>BB</sub>	±3.4 %	R	√3	0.78	0.71	±1.5 %	±1.4 %
EPS	Phantom Permittivity	±14.0 %	R	√3	0.25	0.25	±2.0 %	±2.0 %
DAS	Distance DUT - TSL	±2.0 %	N	1	2	2	±4.0 %	±4.0 %
H	Device Holder	±3.6 %	N	1	1	1	±3.6 %	±3.6 %
MOD	DUT Modulation <sub>m</sub>	±2.4 %	R	√3	1	1	±1.4 %	±1.4 %
TAS	Time-average SAR	±2.6 %	R	√3	1	1	±1.5 %	±1.5 %
RF <sub>drift</sub>	DUT drift	±5.0 %	N	1	1	1	±2.9 %	±2.9 %
<b>Correction to the SAR results</b>								
C(ε, σ)	Deviation to Target	±1.9 %	N	1	1	0.84	±1.9 %	±1.6 %
Combined Std. Uncertainty							±11.5 %	±11.4 %
<b>Expanded STD Uncertainty</b>							<b>±23.1 %</b>	<b>±22.9 %</b>

### A.7 RF Exposure Limits

SAR assessments have been made in line with the requirements of FCC 47 CFR Part 2.1093 on the limitation of exposure of the general population / uncontrolled exposure for portable devices.

Exposure Type	General Population / Uncontrolled Environment
Peak spatial-average SAR (averaged over any 1 gram of tissue)	<b>1.6 W/kg</b>
Whole body average SAR	<b>0.08 W/kg</b>
Peak spatial-average SAR (extremities) (averaged over any 10 grams of tissue)	<b>4.0 W/kg</b>

# Annex B. Test Results

---

The herein test results were performed by:

Test case measurement	Test Personnel
SAR measurement	E. Garcia, M. Lefebvre
Conducted measurement	F. Heurtematte

## B.1 Test Conditions

### B.1.1 Test SAR Test positions relative to the phantom

The device under test was a Notebook PC host platform (HP) HSN-I50C using L860-GL-16 WWAN module and PIFA antennas. The card was operated utilizing HP proprietary software (RD Tool v1.0.2) and each channel was measured using a communication tester to determine the maximum average power.

The device has 1 power setting:

- Laptop mode

See section 6 for details about power values for the configuration

See Annex F.3 for information about the platform antenna configuration

#### Laptop mode

According to FCC OET KDB 616217 D04, laptop position should be tested for SAR compliance with the display screen opened at an angle of 90° to the keyboard compartment and the notebook bottom surface must be touching the phantom.

Notebook	WWAN Ant 5 (TX/RX)
Position	• Laptop

See B.1.3.1 for a more detailed list of the applied reductions.

See section F.2 for more information on the tested positions.

### B.1.2 Test signal, Output power and Test Frequencies

#### B.1.2.1 LTE TDD consideration

According to KDB 941225 D05 SAR for LTE Devices, for Time-Division Duplex (TDD) systems, SAR must be tested using a fixed periodic duty factor according to the highest transmission duty factor implemented for the device and supported by the defined 3GPP LTE TDD configurations.

LTE TDD Bands support 3GPP TS 36.211 section 4.2 for Type 2 Frame structure and table 2 for uplink-downlink configurations and table 1 for special subframe configurations

**Table 1**

Special subframe configuration	Normal cyclic prefix in downlink			Extended cyclic prefix in downlink		
	DwPTS	UpPTS		DwPTS	UpPTS	
		Normal cyclic prefix in uplink	Extended cyclic prefix in uplink		Normal cyclic prefix in uplink	Extended cyclic prefix in uplink
0	6592 T <sub>s</sub>	(1+X) 2192 T <sub>s</sub>	(1+X) 2560 T <sub>s</sub>	7680 · T <sub>s</sub>	(1+X) 2192 T <sub>s</sub>	(1+X) 2560 T <sub>s</sub>
1	19760 T <sub>s</sub>			20480 T <sub>s</sub>		
2	21952 T <sub>s</sub>			23040 T <sub>s</sub>		
3	24144 T <sub>s</sub>			25600 T <sub>s</sub>		
4	26336 T <sub>s</sub>			7680 T <sub>s</sub>		
5	6592 T <sub>s</sub>	(2+X) 2192 T <sub>s</sub>	(2+X) 2560 T <sub>s</sub>	20480 T <sub>s</sub>	(2+X) 2192 T <sub>s</sub>	(2+X) 2560 T <sub>s</sub>
6	19760 T <sub>s</sub>			23040 T <sub>s</sub>		
7	21952 T <sub>s</sub>			12800 T <sub>s</sub>		
8	24144 T <sub>s</sub>			-		
9	13168 T <sub>s</sub>			-		
10	13168 T <sub>s</sub>	13150 T <sub>s</sub>	12800 T <sub>s</sub>	-	-	-

**Table2**

Uplink-Downlink Config.	Downlink-to-Uplink Switch-point Periodicity	Subframe Number										Calculated Duty Cycle (%)
		0	1	2	3	4	5	6	7	8	9	
0	5 ms	D	S	U	U	U	D	S	U	U	U	63.3%
1	5 ms	D	S	U	U	D	D	S	U	U	D	43.3%
2	5 ms	D	S	U	D	D	D	S	U	D	D	23.3%
3	10 ms	D	S	U	U	U	D	D	D	D	D	31.7%
4	10 ms	D	S	U	U	D	D	D	D	D	D	21.7%
5	10 ms	D	S	U	D	D	D	D	D	D	D	11.7%
6	5 ms	D	S	U	U	U	D	S	U	U	D	53.3%

Calculated duty cycle = Extended cyclic prefix in uplink \*(TS )\*# of S + # of U / period  
 The configuration used for SAR testing was the number 0 which corresponds to the highest duty cycle (Power Class 3)

### B.1.3 Evaluation Exclusion and Test Reductions

#### B.1.3.1 SAR evaluation exclusion

The SAR Test Exclusion Threshold in FCC OET KDB 447498 D01 v06 can be applied to determine SAR test exclusion for adjacent edge configurations. For 100MHz to 6GHz and test separation distances ≤50mm, the 1-g and 10-g SAR test exclusion thresholds are determined by the following formula:

$$\left[ \frac{\text{(max. power of channel, including tune – up tolerance, mW)}}{\text{(min. test separation distance, mm)}} \right] \cdot \left[ \sqrt{f_{\text{(GHz)}}} \right] \tag{1}$$

*≤ 3.0 for 1g SAR, and ≤ 7.5 for 10g extremity SAR*

Where:

- f(GHz) is the RF channel transmit frequency in GHz
- Power and distance are rounded to the nearest mW and mm before calculation
- The result is rounded to one decimal place for comparison
- The values 3.0 and 7.5 are referred to as numeric thresholds

The test exclusions are applicable only when the minimum test separation distance is ≤ 50 mm, and for transmission frequencies between 100 MHz and 6 GHz. When the minimum test separation distance is < 5 mm, a distance of 5 mm is applied to determine SAR test exclusion.

For test separation distances > 50 mm, the 1-g and 10-g SAR test exclusion thresholds are determined using the following formulas:

$$\left( \text{(Power allowed at numeric threshold for 50 mm in (1))} + \text{(test separation distance – 50 mm)} \cdot \text{(} f_{\text{MHz}}/150 \text{))} \right) \text{mW}, \tag{2}$$

*for 100MHz to 1500MHz*

$$\left( \text{(Power allowed at numeric threshold for 50 mm in (1))} + \text{(test separation distance – 50 mm)} \cdot 10 \right) \text{mW}, \tag{3}$$

*for 1500MHz and ≤ 6GHz*

#### Test Exclusion

Antenna	Band Name	Output power		Distance from edge (mm)	Laptop position
		dBm	mW		
WWAN (Ant5 Tx/Rx)	FDD II	17.5	56.2	<50	T
	FDD IV	17.5	56.2	<50	T
	FDD V	21.5	141.3	<50	T
	LTE 2	17.5	56.2	<50	R
	LTE 4	17.5	56.2	<50	R
	LTE 5	21.5	141.3	<50	T*
	LTE 7	16.0	39.8	<50	T
	LTE 12	22.0	158.5	<50	T
	LTE 13	22.0	158.5	<50	T
	LTE 14	21.5	141.3	<50	T
	LTE 17	22.0	158.5	<50	R
	LTE 25	17.5	56.2	<50	T
	LTE 26	21.5	141.3	<50	T
	LTE 30	17.5	56.2	<50	T
	LTE 38	16.0	39.8	<50	T
	LTE 41	16.0	39.8	<50	T
	LTE 48	18.0	63.1	<50	T
LTE 66	20.5	112.2	<50	T	

T: Tested position  
 R: Reduced  
 T\*: Tested only for ULCA

See Annex F for a more detailed explanation of the separation distance related to the platform.



**B.1.3.2 General SAR test reduction**

According to FCC OET KDB 447498 D01, testing of other required channels within the operating mode of a frequency band is not required when the reported 1-g or 10-g SAR for the mid-band or highest output power channel is:

- ≤ 0.8 W/kg or 2.0 W/kg, for 1-g or 10-g respectively, when the transmission band is ≤ 100 MHz
- ≤ 0.6 W/kg or 1.5 W/kg, for 1-g or 10-g respectively, when the transmission band is between 100 MHz and 200 MHz
- ≤ 0.4 W/kg or 1.0 W/kg, for 1-g or 10-g respectively, when the transmission band is ≥ 200 MHz

**WWAN SAR Test reduction**

Transmission Mode	SAR test exclusion/reduction
HSDPA	According to FCC OET KDB 941225 D01, SAR evaluation is not required when the maximum average output power is < ¼ dB higher than the measured on the corresponding channels without HSDPA, using 12.2kbps RMC, and the maximum SAR for 12.2kbps RMC is < 1.2 W/kg.
HSUPA	According to FCC OET KDB 941225 D01, SAR evaluation is not required when the maximum average output power is < ¼ dB higher than the measured on the corresponding channels without HSUPA, using 12.2kbps RMC, and the maximum SAR for 12.2kbps RMC is < 1.2 W/kg.
DC+HSDPA	According to FCC OET KDB 941225 D01, SAR evaluation is not required when the maximum average output power is < ¼ dB higher than the measured on the corresponding channels without DC+HSDPA, using 12.2kbps RMC, and the maximum SAR for 12.2kbps RMC is < 1.2 W/kg.
LTE	<p>According to FCC OET KDB 941225 D05, testing of 100% RB allocation, higher order modulations or lower BW is not required when these conditions are met:</p> <ul style="list-style-type: none"> <li>○ For QPSK with 100% RB allocation, SAR is not required when the highest maximum output power for 100 % RB allocation is less than the highest maximum output power in 50% and 1 RB allocations and the highest reported SAR for 1 RB and 50% RB allocation are ≤ 0.8 W/kg.</li> <li>○ For each modulation besides QPSK, SAR is required only when the highest maximum output power for the configuration in the higher order modulation is &gt; ½ dB higher than the same configuration in QPSK or when the reported SAR for the QPSK configuration is &gt; 1.45 W/kg.</li> <li>○ For lower BW, only measure SAR when the highest maximum output power of a configuration requiring testing in the smaller channel bandwidth is &gt; ½ dB higher than the equivalent channel configurations in the largest channel bandwidth configuration or the reported SAR of a configuration for the largest channel bandwidth is &gt; 1.45 W/kg.</li> </ul> <p>For LTE bands that do not support at least three non-overlapping channels in certain channel bandwidths, test the available non-overlapping channels instead. When a device supports overlapping channel assignment in a channel bandwidth configuration, the middle channel of the group of overlapping channels should be selected for testing; therefore, the requirement for H, M, and L channels may not fully apply</p>

## B.2 Conducted Power Measurements – Tablet mode

### B.2.1 WCDMA/ HSPA/ DC-HSPA

#### B.2.1.1 WCDMA Band II

Mode	Channel Number	Freq (MHz)	Subset	Average Power Measured (dBm)	Factory Upper Tolerance (dBm)
RMC	9262	1852.4	-	17.15	17.50
	9400	1880	-	17.05	17.50
	9538	1907.6	-	17.04	17.50
HSDPA	9262	1852.4	1	16.94	17.50
			2	17.06	17.50
			3	17.12	17.50
			4	16.96	17.50
	9400	1880	1	17.01	17.50
			2	17.09	17.50
			3	16.94	17.50
			4	16.96	17.50
	9538	1907.6	1	17.03	17.50
			2	16.90	17.50
			3	16.98	17.50
			4	17.02	17.50
HSUPA	9262	1852.4	1	17.05	17.50
			2	17.03	17.50
			3	17.05	17.50
			4	17.04	17.50
			5	16.99	17.50
	9400	1880	1	17.01	17.50
			2	17.04	17.50
			3	17.01	17.50
			4	17.06	17.50
			5	17.01	17.50
	9538	1907.6	1	17.09	17.50
			2	16.99	17.50
			3	16.99	17.50
			4	16.97	17.50
			5	16.97	17.50
DC-HSDPA	9262	1852.4	1	16.93	17.50
			2	17.06	17.50
			3	17.13	17.50
			4	16.95	17.50
	9400	1880	1	17.01	17.50
			2	17.07	17.50
			3	16.96	17.50
			4	16.95	17.50
	9538	1907.6	1	16.97	17.50
			2	16.92	17.50
			3	16.90	17.50
			4	17.03	17.50

**B.2.1.2 WCDMA Band IV**

Mode	Channel Number	Freq (MHz)	Subset	Average Power Measured (dBm)	Factory Upper Tolerance (dBm)
RMC	1312	1712.4	-	17.41	17.50
	1413	1732.6	-	17.27	17.50
	1513	1752.6	-	17.27	17.50
HSDPA	1312	1712.4	1	17.44	17.50
			2	17.38	17.50
			3	17.40	17.50
			4	17.36	17.50
	1413	1732.6	1	17.39	17.50
			2	17.43	17.50
			3	17.35	17.50
			4	17.40	17.50
	1513	1752.6	1	17.43	17.50
			2	17.33	17.50
			3	17.34	17.50
			4	17.39	17.50
HSUPA	1312	1712.4	1	17.46	17.50
			2	17.39	17.50
			3	17.41	17.50
			4	17.42	17.50
			5	17.37	17.50
	1413	1732.6	1	17.41	17.50
			2	17.44	17.50
			3	17.35	17.50
			4	17.39	17.50
			5	17.46	17.50
	1513	1752.6	1	17.38	17.50
			2	17.42	17.50
			3	17.43	17.50
			4	17.37	17.50
			5	17.37	17.50
DC-HSDPA	1312	1712.4	1	17.41	17.50
			2	17.37	17.50
			3	17.42	17.50
			4	17.34	17.50
	1413	1732.6	1	17.39	17.50
			2	17.43	17.50
			3	17.34	17.50
			4	17.37	17.50
	1513	1752.6	1	17.43	17.50
			2	17.33	17.50
			3	17.35	17.50
			4	17.37	17.50

**B.2.1.3 WCDMA Band V**

Mode	Channel Number	Freq (MHz)	Subset	Average Power Measured (dBm)	Factory Upper Tolerance (dBm)
RMC	4132	826.4	-	21.07	21.50
	4183	836.6	-	21.08	21.50
	4233	846.6	-	21.09	21.50
HSDPA	4132	826.4	1	21.12	21.50
			2	21.10	21.50
			3	21.00	21.50
			4	21.15	21.50
	4183	836.6	1	21.12	21.50
			2	21.03	21.50
			3	21.13	21.50
			4	21.13	21.50
	4233	846.6	1	21.00	21.50
			2	21.14	21.50
			3	21.14	21.50
			4	21.05	21.50
HSUPA	4132	826.4	1	21.13	21.50
			2	21.12	21.50
			3	20.99	21.50
			4	21.15	21.50
			5	21.12	21.50
	4183	836.6	1	21.03	21.50
			2	21.13	21.50
			3	21.12	21.50
			4	21.05	21.50
			5	21.17	21.50
	4233	846.6	1	21.14	21.50
			2	21.08	21.50
			3	21.11	21.50
			4	21.18	21.50
			5	21.08	21.50
DC- HSDPA	4132	826.4	1	21.07	21.50
			2	21.11	21.50
			3	21.05	21.50
			4	21.12	21.50
	4183	836.6	1	21.14	21.50
			2	21.02	21.50
			3	21.13	21.50
			4	21.16	21.50
	4233	846.6	1	21.05	21.50
			2	21.20	21.50
			3	21.13	21.50
			4	21.00	21.50

## **B.2.2 LTE**

### **B.2.2.1 LTE Band 2 FDD**

SAR Measurement for LTE Band 2 FDD (Frequency range: 1850 – 1910MHz) is covered by LTE Band 25 FDD (Frequency range: 1850 – 1915MHz) due to overlapping frequency range, same maximum tune-up and same bandwidth.

### **B.2.2.2 LTE Band 4 FDD**

SAR Measurement for LTE Band 4 FDD (Frequency range: 1710 – 1755MHz) is covered by LTE Band 66 FDD (Frequency range: 1710 – 1780MHz) due to overlapping frequency range, same maximum tune-up and same bandwidth.

### **B.2.2.3 LTE Band 5 FDD**

SAR Measurement for LTE Band 5 FDD (Frequency range: 824 – 849MHz) is covered by LTE Band 26 FDD (Frequency range: 814 – 849MHz) due to overlapping frequency range, same maximum tune-up and same bandwidth.

**B.2.2.4 LTE Band 7 FDD**

Band	BW	Channel #	Freq (MHz)	% RB Allocation	RB Position	QPSK			16 QAM		
						Factory Upper Tolerance (dBm)	M P R	Measured Output Power (dBm)	Factory Upper Tolerance (dBm)	M P R	Measured Output Power (dBm)
LTE 7	20 MHz	20850	2510	1RB Low	1 Pos 0	16.00	0	15.49	16.00	0	15.75
				1RB Mid	1 Pos 50	16.00	0	15.26	16.00	0	15.30
				1RB High	1 Pos 99	16.00	0	15.27	16.00	0	15.39
				50% RB Low	50 Pos 0	16.00	0	15.31	16.00	0	15.32
				50% RB Mid	50 Pos 24	16.00	0	15.30	16.00	0	15.30
				50% RB High	50 Pos 50	16.00	0	15.19	16.00	0	15.18
		100% RB	100 Pos 0	16.00	0	15.22	16.00	0	15.20		
		21100	2535	1RB Low	1 Pos 0	16.00	0	15.24	16.00	0	15.54
				1RB Mid	1 Pos 50	16.00	0	15.40	16.00	0	15.63
				1RB High	1 Pos 99	16.00	0	15.62	16.00	0	15.80
				50% RB Low	50 Pos 0	16.00	0	15.31	16.00	0	15.33
				50% RB Mid	50 Pos 24	16.00	0	15.33	16.00	0	15.35
				50% RB High	50 Pos 50	16.00	0	15.48	16.00	0	15.47
		100% RB	100 Pos 0	16.00	0	15.45	16.00	0	15.46		
		21350	2560	1RB Low	1 Pos 0	16.00	0	15.33	16.00	0	15.30
				1RB Mid	1 Pos 50	16.00	0	15.31	16.00	0	15.31
				1RB High	1 Pos 99	16.00	0	15.45	16.00	0	15.58
				50% RB Low	50 Pos 0	16.00	0	15.23	16.00	0	15.25
	50% RB Mid			50 Pos 24	16.00	0	15.28	16.00	0	15.26	
	50% RB High			50 Pos 50	16.00	0	15.43	16.00	0	15.46	
	100% RB	100 Pos 0	16.00	0	15.37	16.00	0	15.37			
	15 MHz	20825	2507.5	1RB Low	1 Pos 0	16.00	0	15.45	16.00	0	15.55
				1RB Mid	1 Pos 38	16.00	0	15.33	16.00	0	15.57
				1RB High	1 Pos 74	16.00	0	15.13	16.00	0	15.24
				50% RB Low	38 Pos 0	16.00	0	15.34	16.00	0	15.38
				50% RB Mid	38 Pos 19	16.00	0	15.33	16.00	0	15.35
				50% RB High	38 Pos 39	16.00	0	15.24	16.00	0	15.23
		100% RB	75 Pos 0	16.00	0	15.31	16.00	0	15.31		
		21100	2535	1RB Low	1 Pos 0	16.00	0	15.31	16.00	0	15.47
				1RB Mid	1 Pos 38	16.00	0	15.39	16.00	0	15.49
				1RB High	1 Pos 74	16.00	0	15.50	16.00	0	15.64
				50% RB Low	38 Pos 0	16.00	0	15.27	16.00	0	15.29
				50% RB Mid	38 Pos 19	16.00	0	15.35	16.00	0	15.37
				50% RB High	38 Pos 39	16.00	0	15.43	16.00	0	15.45
		100% RB	75 Pos 0	16.00	0	15.43	16.00	0	15.42		
		21375	2562.5	1RB Low	1 Pos 0	16.00	0	15.24	16.00	0	15.41
				1RB Mid	1 Pos 38	16.00	0	15.33	16.00	0	15.47
				1RB High	1 Pos 74	16.00	0	15.43	16.00	0	15.56
				50% RB Low	38 Pos 0	16.00	0	15.29	16.00	0	15.30
	50% RB Mid			38 Pos 19	16.00	0	15.33	16.00	0	15.30	
	50% RB High			38 Pos 39	16.00	0	15.43	16.00	0	15.43	
	100% RB	75 Pos 0	16.00	0	15.39	16.00	0	15.41			
	10 MHz	20800	2505	1RB Low	1 Pos 0	16.00	0	15.43	16.00	0	15.70
				1RB Mid	1 Pos 24	16.00	0	15.37	16.00	0	15.53
				1RB High	1 Pos 49	16.00	0	15.28	16.00	0	15.40
				50% RB Low	25 Pos 0	16.00	0	15.37	16.00	0	15.43
				50% RB Mid	25 Pos 12	16.00	0	15.38	16.00	0	15.36
				50% RB High	25 Pos 25	16.00	0	15.35	16.00	0	15.36
		100% RB	50 Pos0	16.00	0	15.35	16.00	0	15.34		
		21100	2535	1RB Low	1 Pos 0	16.00	0	15.35	16.00	0	15.41
				1RB Mid	1 Pos 24	16.00	0	15.33	16.00	0	15.46
				1RB High	1 Pos 49	16.00	0	15.57	16.00	0	15.71
				50% RB Low	25 Pos 0	16.00	0	15.31	16.00	0	15.24
				50% RB Mid	25 Pos 12	16.00	0	15.33	16.00	0	15.37
				50% RB High	25 Pos 25	16.00	0	15.44	16.00	0	15.47
		100% RB	50 Pos0	16.00	0	15.38	16.00	0	15.39		
		21400	2565	1RB Low	1 Pos 0	16.00	0	15.33	16.00	0	15.45
				1RB Mid	1 Pos 24	16.00	0	15.45	16.00	0	15.65
				1RB High	1 Pos 49	16.00	0	15.44	16.00	0	15.76
				50% RB Low	25 Pos 0	16.00	0	15.36	16.00	0	15.38
50% RB Mid	25 Pos 12			16.00	0	15.40	16.00	0	15.41		
50% RB High	25 Pos 25			16.00	0	15.44	16.00	0	15.43		
100% RB	50 Pos0	16.00	0	15.43	16.00	0	15.46				

Band	BW	Channel #	Freq (MHz)	% RB Allocation	RB Position	QPSK			16 QAM		
						Factory Upper Tolerance (dBm)	M P R	Measured Output Power (dBm)	Factory Upper Tolerance (dBm)	M P R	Measured Output Power (dBm)
LTE 7	5 MHz	20775	2502.5	1RB Low	1 Pos 0	16.00	0	15.51	16.00	0	15.67
				1RB Mid	1 Pos 12	16.00	0	15.41	16.00	0	15.45
				1RB High	1 Pos 24	16.00	0	15.41	16.00	0	15.56
				50% RB Low	12 Pos 0	16.00	0	15.29	16.00	0	15.36
				50% RB Mid	12 Pos 6	16.00	0	15.25	16.00	0	15.26
				50% RB High	12 Pos 11	16.00	0	15.26	16.00	0	15.28
		21100	2535	100% RB	25 Pos 0	16.00	0	15.30	16.00	0	15.24
				1RB Low	1 Pos 0	16.00	0	15.32	16.00	0	15.47
				1RB Mid	1 Pos 12	16.00	0	15.34	16.00	0	15.49
				1RB High	1 Pos 24	16.00	0	15.45	16.00	0	15.72
				50% RB Low	12 Pos 0	16.00	0	15.14	16.00	0	15.11
				50% RB Mid	12 Pos 6	16.00	0	15.14	16.00	0	15.10
		21425	2567.5	50% RB High	12 Pos 11	16.00	0	15.22	16.00	0	15.19
				100% RB	25 Pos 0	16.00	0	15.24	16.00	0	15.15
				1RB Low	1 Pos 0	16.00	0	15.40	16.00	0	15.54
				1RB Mid	1 Pos 12	16.00	0	15.41	16.00	0	15.48
				1RB High	1 Pos 24	16.00	0	15.47	16.00	0	15.59
				50% RB Low	12 Pos 0	16.00	0	15.25	16.00	0	15.26
		50% RB Mid	12 Pos 6	16.00	0	15.29	16.00	0	15.25		
		50% RB High	12 Pos 11	16.00	0	15.21	16.00	0	15.12		
		100% RB	25 Pos 0	16.00	0	15.30	16.00	0	15.25		

**B.2.2.5 LTE Band 12 FDD**

Band	BW	Channel #	Freq (MHz)	% RB Allocation	RB Position	QPSK			16 QAM		
						Factory Upper Tolerance (dBm)	M P R	Measured Output Power (dBm)	Factory Upper Tolerance (dBm)	M P R	Measured Output Power (dBm)
LTE 12	10 MHz	23095	707.5	1RB Low	1 Pos 0	22.00	0	20.85	22.00	0	21.11
				1RB Mid	1 Pos 24	22.00	0	20.68	22.00	0	21.05
				1RB High	1 Pos 49	22.00	0	20.69	22.00	0	20.78
				50% RB Low	25 Pos 0	22.00	0	20.73	22.00	0	20.72
				50% RB Mid	25 Pos 12	22.00	0	20.62	22.00	0	20.58
				50% RB High	25 Pos 24	22.00	0	20.56	22.00	0	20.52
	5 MHz	23035	701.5	1RB Low	1 Pos 0	22.00	0	20.68	22.00	0	20.81
				1RB Mid	1 Pos 12	22.00	0	20.74	22.00	0	20.92
				1RB High	1 Pos 24	22.00	0	20.80	22.00	0	20.83
				50% RB Low	12 Pos 0	22.00	0	20.62	22.00	0	20.70
				50% RB Mid	12 Pos 6	22.00	0	20.67	22.00	0	20.69
				50% RB High	12 Pos 11	22.00	0	20.74	22.00	0	20.73
		23095	707.5	100% RB	25 Pos 0	22.00	0	20.72	22.00	0	20.76
				1RB Low	1 Pos 0	22.00	0	20.79	22.00	0	20.99
				1RB Mid	1 Pos 12	22.00	0	20.69	22.00	0	20.97
				1RB High	1 Pos 24	22.00	0	20.63	22.00	0	20.78
				50% RB Low	12 Pos 0	22.00	0	20.67	22.00	0	20.58
				50% RB Mid	12 Pos 6	22.00	0	20.62	22.00	0	20.57
		23155	713.5	50% RB High	12 Pos 11	22.00	0	20.58	22.00	0	20.50
				100% RB	25 Pos 0	22.00	0	20.60	22.00	0	20.59
				1RB Low	1 Pos 0	22.00	0	20.72	22.00	0	20.78
				1RB Mid	1 Pos 12	22.00	0	20.87	22.00	0	20.99
				1RB High	1 Pos 24	22.00	0	20.78	22.00	0	20.83
				50% RB Low	12 Pos 0	22.00	0	20.70	22.00	0	20.66
	3 MHz	23025	700.5	50% RB Mid	12 Pos 6	22.00	0	20.80	22.00	0	20.69
				50% RB High	12 Pos 11	22.00	0	20.81	22.00	0	20.72
				100% RB	25 Pos 0	22.00	0	20.77	22.00	0	20.79
				1RB Low	1 Pos 0	22.00	0	20.63	22.00	0	20.65
				1RB Mid	1 Pos 7	22.00	0	20.66	22.00	0	21.02
				1RB High	1 Pos 14	22.00	0	20.72	22.00	0	20.91
		23095	707.5	50% RB Low	8 Pos 0	22.00	0	20.65	22.00	0	20.73
				50% RB Mid	8 Pos 4	22.00	0	20.65	22.00	0	20.69
				50% RB High	8 Pos 7	22.00	0	20.67	22.00	0	20.68
				100% RB	15 Pos 0	22.00	0	20.64	22.00	0	20.62
				1RB Low	1 Pos 0	22.00	0	20.69	22.00	0	20.63
				1RB Mid	1 Pos 7	22.00	0	20.62	22.00	0	20.89
		23165	714.5	1RB High	1 Pos 14	22.00	0	20.58	22.00	0	20.85
				50% RB Low	8 Pos 0	22.00	0	20.67	22.00	0	20.70
				50% RB Mid	8 Pos 4	22.00	0	20.65	22.00	0	20.63
				50% RB High	8 Pos 7	22.00	0	20.60	22.00	0	20.66
				100% RB	15 Pos 0	22.00	0	20.63	22.00	0	20.65
				1RB Low	1 Pos 0	22.00	0	20.79	22.00	0	20.97



Band	BW	Channel #	Freq (MHz)	% RB Allocation	RB Position	QPSK			16 QAM		
						Factory Upper Tolerance (dBm)	M P R	Measured Output Power (dBm)	Factory Upper Tolerance (dBm)	M P R	Measured Output Power (dBm)
LTE 12	1.4 MHz	23017	699.7	1RB Low	1 Pos 0	22.00	0	20.71	22.00	0	20.77
				1RB Mid	1 Pos 2	22.00	0	20.66	22.00	0	20.80
				1RB High	1 Pos 5	22.00	0	20.70	22.00	0	20.71
				50% RB Low	3 Pos 0	22.00	0	20.63	22.00	0	20.62
				50% RB Mid	3 Pos 1	22.00	0	20.61	22.00	0	20.64
				50% RB High	3 Pos 2	22.00	0	20.60	22.00	0	20.62
		23095	707.5	100% RB	6 Pos 0	22.00	0	20.61	22.00	0	20.64
				1RB Low	1 Pos 0	22.00	0	20.72	22.00	0	20.93
				1RB Mid	1 Pos 2	22.00	0	20.67	22.00	0	20.83
				1RB High	1 Pos 5	22.00	0	20.68	22.00	0	20.76
				50% RB Low	3 Pos 0	22.00	0	20.68	22.00	0	20.81
				50% RB Mid	3 Pos 1	22.00	0	20.68	22.00	0	20.84
		23173	715.3	50% RB High	3 Pos 2	22.00	0	20.65	22.00	0	20.75
				100% RB	6 Pos 0	22.00	0	20.62	22.00	0	20.73
				1RB Low	1 Pos 0	22.00	0	20.88	22.00	0	20.80
				1RB Mid	1 Pos 2	22.00	0	20.79	22.00	0	20.77
				1RB High	1 Pos 5	22.00	0	20.81	22.00	0	21.02
				50% RB Low	3 Pos 0	22.00	0	20.71	22.00	0	20.83
50% RB Mid	3 Pos 1	22.00	0	20.74	22.00	0	20.86				
50% RB High	3 Pos 2	22.00	0	20.75	22.00	0	20.82				
100% RB	6 Pos 0	22.00	0	20.75	22.00	0	20.78				

**B.2.2.6 LTE Band 13 FDD**

Band	BW	Channel #	Freq (MHz)	% RB Allocation	RB Position	QPSK			16 QAM		
						Factory Upper Tolerance (dBm)	M P R	Measured Output Power (dBm)	Factory Upper Tolerance (dBm)	M P R	Measured Output Power (dBm)
LTE 13	10 MHz	23230	782	1RB Low	1 Pos 0	22.00	0	21.32	22.00	0	21.47
				1RB Mid	1 Pos 24	22.00	0	21.35	22.00	0	21.56
				1RB High	1 Pos 49	22.00	0	21.23	22.00	0	21.46
				50% RB Low	25 Pos 0	22.00	0	21.25	22.00	0	20.69
				50% RB Mid	25 Pos 12	22.00	0	21.30	22.00	0	20.80
				50% RB High	25 Pos 24	22.00	0	21.21	22.00	0	20.75
				100% RB	50 Pos 0	22.00	0	21.33	22.00	0	20.84
	5.0 MHz	23230	782	1RB Low	1 Pos 0	22.00	0	21.24	22.00	0	21.47
				1RB Mid	1 Pos 12	22.00	0	21.27	22.00	0	21.28
				1RB High	1 Pos 24	22.00	0	21.28	22.00	0	21.44
				50% RB Low	12 Pos 0	22.00	0	21.09	22.00	0	20.61
				50% RB Mid	12 Pos 6	22.00	0	21.20	22.00	0	20.69
				50% RB High	12 Pos 11	22.00	0	21.19	22.00	0	20.62
				100% RB	25 Pos 0	22.00	0	21.18	22.00	0	20.64

**B.2.2.7 LTE Band 14 FDD**

Band	BW	Channel #	Freq (MHz)	% RB Allocation	RB Position	QPSK			16 QAM		
						Factory Upper Tolerance (dBm)	M P R	Measured Output Power (dBm)	Factory Upper Tolerance (dBm)	M P R	Measured Output Power (dBm)
LTE 14	10 MHz	23330	793	1RB Low	1 Pos 0	21.50	0	20.51	21.50	0	20.78
				1RB Mid	1 Pos 24	21.50	0	20.58	21.50	0	20.72
				1RB High	1 Pos 49	21.50	0	20.59	21.50	0	20.77
				50% RB Low	25 Pos 0	21.50	0	20.49	21.50	0	20.50
				50% RB Mid	25 Pos 12	21.50	0	20.50	21.50	0	20.58
				50% RB High	25 Pos 24	21.50	0	20.53	21.50	0	20.56
				100% RB	50 Pos 0	21.50	0	20.60	21.50	0	20.64
	5.0 MHz	23330	793	1RB Low	1 Pos 0	21.50	0	20.49	21.50	0	20.62
				1RB Mid	1 Pos 12	21.50	0	20.58	21.50	0	20.80
				1RB High	1 Pos 24	21.50	0	20.63	21.50	0	20.65
				50% RB Low	12 Pos 0	21.50	0	20.35	21.50	0	20.36
				50% RB Mid	12 Pos 6	21.50	0	20.40	21.50	0	20.43
				50% RB High	12 Pos 11	21.50	0	20.45	21.50	0	20.45
				100% RB	25 Pos 0	21.50	0	20.46	21.50	0	20.41

#### **B.2.2.8 LTE Band 17 FDD**

SAR Measurement for LTE Band 17 FDD (Frequency range: 704 – 716MHz) is covered by LTE Band 12 FDD (Frequency range: 699 – 716MHz) due to overlapping frequency range, same maximum tune-up and same bandwidth.

**B.2.2.9 LTE Band 25 FDD**

Band	BW	Channel #	Freq (MHz)	% RB Allocation	RB Position	QPSK			16 QAM		
						Factory Upper Tolerance (dBm)	M P R	Measured Output Power (dBm)	Factory Upper Tolerance (dBm)	M P R	Measured Output Power (dBm)
LTE 25	20 MHz	26140	1860.0	1RB Low	1 Pos 0	17.50	0	16.42	17.50	0	16.59
				1RB Mid	1 Pos 50	17.50	0	16.60	17.50	0	16.74
				1RB High	1 Pos 99	17.50	0	16.45	17.50	0	16.46
				50% RB Low	50 Pos 0	17.50	0	16.57	17.50	0	16.57
				50% RB Mid	50 Pos 24	17.50	0	16.67	17.50	0	16.65
				50% RB High	50 Pos 50	17.50	0	16.51	17.50	0	16.49
		100% RB	100 Pos 0	17.50	0	16.59	17.50	0	16.55		
		26365	1882.5	1RB Low	1 Pos 0	17.50	0	16.40	17.50	0	16.64
				1RB Mid	1 Pos 50	17.50	0	16.57	17.50	0	16.76
				1RB High	1 Pos 99	17.50	0	16.79	17.50	0	17.07
				50% RB Low	50 Pos 0	17.50	0	16.37	17.50	0	16.38
				50% RB Mid	50 Pos 24	17.50	0	16.64	17.50	0	16.63
				50% RB High	50 Pos 50	17.50	0	16.69	17.50	0	16.68
		100% RB	100 Pos 0	17.50	0	16.85	17.50	0	16.80		
		26590	1905.0	1RB Low	1 Pos 0	17.50	0	16.74	17.50	0	16.79
				1RB Mid	1 Pos 50	17.50	0	16.54	17.50	0	16.63
				1RB High	1 Pos 99	17.50	0	16.66	17.50	0	16.66
				50% RB Low	50 Pos 0	17.50	0	16.52	17.50	0	16.51
	50% RB Mid			50 Pos 24	17.50	0	16.64	17.50	0	16.60	
	50% RB High			50 Pos 50	17.50	0	16.79	17.50	0	16.81	
	100% RB	100 Pos 0	17.50	0	17.00	17.50	0	16.95			
	15 MHz	26115	1857.5	1RB Low	1 Pos 0	17.50	0	16.35	17.50	0	16.47
				1RB Mid	1 Pos 38	17.50	0	16.56	17.50	0	16.80
				1RB High	1 Pos 74	17.50	0	16.49	17.50	0	16.71
				50% RB Low	38 Pos 0	17.50	0	16.60	17.50	0	16.58
				50% RB Mid	38 Pos 19	17.50	0	16.59	17.50	0	16.60
				50% RB High	38 Pos 39	17.50	0	16.57	17.50	0	16.61
		100% RB	75 Pos 0	17.50	0	16.60	17.50	0	16.62		
		26365	1882.5	1RB Low	1 Pos 0	17.50	0	16.41	17.50	0	16.48
				1RB Mid	1 Pos 38	17.50	0	16.59	17.50	0	16.75
				1RB High	1 Pos 74	17.50	0	16.70	17.50	0	16.78
				50% RB Low	38 Pos 0	17.50	0	16.32	17.50	0	16.34
				50% RB Mid	38 Pos 19	17.50	0	16.60	17.50	0	16.64
				50% RB High	38 Pos 39	17.50	0	16.65	17.50	0	16.72
		100% RB	75 Pos 0	17.50	0	16.74	17.50	0	16.77		
		26615	1907.5	1RB Low	1 Pos 0	17.50	0	16.55	17.50	0	16.89
				1RB Mid	1 Pos 38	17.50	0	16.54	17.50	0	16.69
				1RB High	1 Pos 74	17.50	0	16.60	17.50	0	16.79
				50% RB Low	38 Pos 0	17.50	0	16.54	17.50	0	16.48
	50% RB Mid			38 Pos 19	17.50	0	16.57	17.50	0	16.64	
	50% RB High			38 Pos 39	17.50	0	16.61	17.50	0	16.62	
	100% RB	75 Pos 0	17.50	0	16.75	17.50	0	16.79			
	10 MHz	26090	1855.0	1RB Low	1 Pos 0	17.50	0	16.41	17.50	0	16.50
				1RB Mid	1 Pos 24	17.50	0	16.55	17.50	0	16.77
				1RB High	1 Pos 49	17.50	0	16.62	17.50	0	16.80
				50% RB Low	25 Pos 0	17.50	0	16.56	17.50	0	16.59
				50% RB Mid	25 Pos 12	17.50	0	16.53	17.50	0	16.58
				50% RB High	25 Pos 25	17.50	0	16.56	17.50	0	16.59
100% RB		50 Pos 0	17.50	0	16.59	17.50	0	16.61			
26365		1882.5	1RB Low	1 Pos 0	17.50	0	16.34	17.50	0	16.44	
			1RB Mid	1 Pos 24	17.50	0	16.55	17.50	0	16.62	
			1RB High	1 Pos 49	17.50	0	16.75	17.50	0	16.83	
			50% RB Low	25 Pos 0	17.50	0	16.40	17.50	0	16.41	
			50% RB Mid	25 Pos 12	17.50	0	16.56	17.50	0	16.55	
			50% RB High	25 Pos 25	17.50	0	16.61	17.50	0	16.68	
100% RB		50 Pos 0	17.50	0	16.66	17.50	0	16.64			
26640		1910.0	1RB Low	1 Pos 0	17.50	0	16.49	17.50	0	16.50	
			1RB Mid	1 Pos 24	17.50	0	16.76	17.50	0	16.88	
			1RB High	1 Pos 49	17.50	0	16.73	17.50	0	16.90	
			50% RB Low	25 Pos 0	17.50	0	16.55	17.50	0	16.53	
	50% RB Mid		25 Pos 12	17.50	0	16.71	17.50	0	16.66		
	50% RB High		25 Pos 25	17.50	0	16.63	17.50	0	16.58		
100% RB	50 Pos 0	17.50	0	16.55	17.50	0	16.63				

Band	BW	Channel #	Freq (MHz)	% RB Allocation	RB Position	QPSK			16 QAM		
						Factory Upper Tolerance (dBm)	M P R	Measured Output Power (dBm)	Factory Upper Tolerance (dBm)	M P R	Measured Output Power (dBm)
LTE25	5 MHz	26065	1852.5	1RB Low	1 Pos 0	17.50	0	16.41	17.50	0	16.45
				1RB Mid	1 Pos 38	17.50	0	16.59	17.50	0	16.62
				1RB High	1 Pos 74	17.50	0	16.58	17.50	0	16.78
				50% RB Low	38 Pos 0	17.50	0	16.33	17.50	0	16.34
				50% RB Mid	38 Pos 19	17.50	0	16.48	17.50	0	16.49
				50% RB High	38 Pos 39	17.50	0	16.52	17.50	0	16.48
		100% RB	75 Pos 0	17.50	0	16.47	17.50	0	16.47		
		26365	1882.5	1RB Low	1 Pos 0	17.50	0	16.36	17.50	0	16.51
				1RB Mid	1 Pos 38	17.50	0	16.51	17.50	0	16.73
				1RB High	1 Pos 74	17.50	0	16.63	17.50	0	16.76
				50% RB Low	38 Pos 0	17.50	0	16.34	17.50	0	16.30
				50% RB Mid	38 Pos 19	17.50	0	16.40	17.50	0	16.39
				50% RB High	38 Pos 39	17.50	0	16.53	17.50	0	16.52
		100% RB	75 Pos 0	17.50	0	16.49	17.50	0	16.41		
		26665	1912.5	1RB Low	1 Pos 0	17.50	0	16.82	17.50	0	16.81
				1RB Mid	1 Pos 38	17.50	0	16.66	17.50	0	16.76
				1RB High	1 Pos 74	17.50	0	16.72	17.50	0	16.78
				50% RB Low	38 Pos 0	17.50	0	16.63	17.50	0	16.56
	50% RB Mid			38 Pos 19	17.50	0	16.51	17.50	0	16.43	
	50% RB High			38 Pos 39	17.50	0	16.41	17.50	0	16.41	
	100% RB	75 Pos 0	17.50	0	16.46	17.50	0	16.44			
	3 MHz	26055	1851.5	1RB Low	1 Pos 0	17.50	0	16.24	17.50	0	16.29
				1RB Mid	1 Pos 24	17.50	0	16.33	17.50	0	16.61
				1RB High	1 Pos 49	17.50	0	16.46	17.50	0	16.59
				50% RB Low	25 Pos 0	17.50	0	16.23	17.50	0	16.24
				50% RB Mid	25 Pos 12	17.50	0	16.22	17.50	0	16.12
				50% RB High	25 Pos 24	17.50	0	16.30	17.50	0	16.26
		100% RB	50 Pos 0	17.50	0	16.30	17.50	0	16.20		
		26365	1882.5	1RB Low	1 Pos 0	17.50	0	16.31	17.50	0	16.60
				1RB Mid	1 Pos 24	17.50	0	16.47	17.50	0	16.53
				1RB High	1 Pos 49	17.50	0	16.50	17.50	0	16.55
				50% RB Low	25 Pos 0	17.50	0	16.26	17.50	0	16.20
				50% RB Mid	25 Pos 12	17.50	0	16.33	17.50	0	16.29
				50% RB High	25 Pos 24	17.50	0	16.41	17.50	0	16.41
		100% RB	50 Pos 0	17.50	0	16.37	17.50	0	16.30		
		26675	1913.5	1RB Low	1 Pos 0	17.50	0	16.58	17.50	0	16.80
				1RB Mid	1 Pos 24	17.50	0	16.55	17.50	0	16.49
				1RB High	1 Pos 49	17.50	0	16.57	17.50	0	16.73
				50% RB Low	25 Pos 0	17.50	0	16.37	17.50	0	16.33
	50% RB Mid			25 Pos 12	17.50	0	16.40	17.50	0	16.39	
	50% RB High			25 Pos 24	17.50	0	16.40	17.50	0	16.37	
	100% RB	50 Pos 0	17.50	0	16.42	17.50	0	16.29			
	1.4 MHz	26047	1850.7	1RB Low	1 Pos 0	17.50	0	16.42	17.50	0	16.66
				1RB Mid	1 Pos 12	17.50	0	16.37	17.50	0	16.46
				1RB High	1 Pos 24	17.50	0	16.45	17.50	0	16.17
				50% RB Low	12 Pos 0	17.50	0	16.26	17.50	0	16.32
				50% RB Mid	12 Pos 6	17.50	0	16.22	17.50	0	16.23
				50% RB High	12 Pos 11	17.50	0	16.26	17.50	0	16.33
100% RB		25 Pos 0	17.50	0	16.25	17.50	0	16.21			
26365		1882.5	1RB Low	1 Pos 0	17.50	0	16.49	17.50	0	16.54	
			1RB Mid	1 Pos 12	17.50	0	16.49	17.50	0	16.59	
			1RB High	1 Pos 24	17.50	0	16.54	17.50	0	16.15	
			50% RB Low	12 Pos 0	17.50	0	16.39	17.50	0	16.37	
			50% RB Mid	12 Pos 6	17.50	0	16.33	17.50	0	16.36	
			50% RB High	12 Pos 11	17.50	0	16.41	17.50	0	16.47	
100% RB		25 Pos 0	17.50	0	16.32	17.50	0	16.32			
26683		1914.3	1RB Low	1 Pos 0	17.50	0	16.61	17.50	0	16.75	
			1RB Mid	1 Pos 12	17.50	0	16.62	17.50	0	16.82	
			1RB High	1 Pos 24	17.50	0	16.69	17.50	0	16.53	
			50% RB Low	12 Pos 0	17.50	0	16.44	17.50	0	16.53	
	50% RB Mid		12 Pos 6	17.50	0	16.44	17.50	0	16.53		
	50% RB High		12 Pos 11	17.50	0	16.49	17.50	0	16.63		
100% RB	25 Pos 0	17.50	0	16.40	17.50	0	16.44				

**B.2.2.10 LTE Band 26 FDD**

Band	BW	Channel #	Freq (MHz)	% RB Allocation	RB Position	QPSK			16 QAM		
						Factory Upper Tolerance (dBm)	M P R	Measured Output Power (dBm)	Factory Upper Tolerance (dBm)	M P R	Measured Output Power (dBm)
LTE26	15 MHz	26775	821.5	1RB Low	1 Pos 0	21.50	0	20.97	21.50	0	21.02
				1RB Mid	1 Pos 38	21.50	0	20.95	21.50	0	21.00
				1RB High	1 Pos 74	21.50	0	20.90	21.50	0	21.10
				50% RB Low	38 Pos 0	21.50	0	20.90	21.50	0	21.07
				50% RB Mid	38 Pos 19	21.50	0	20.88	21.50	0	20.88
				50% RB High	38 Pos 39	21.50	0	20.97	21.50	0	20.87
		100% RB	75 Pos 0	21.50	0	20.86	21.50	0	20.86		
		1RB Low	1 Pos 0	21.50	0	20.96	21.50	0	21.06		
		1RB Mid	1 Pos 38	21.50	0	20.88	21.50	0	21.05		
		1RB High	1 Pos 74	21.50	0	20.87	21.50	0	21.09		
		50% RB Low	38 Pos 0	21.50	0	21.10	21.50	0	20.91		
		50% RB Mid	38 Pos 19	21.50	0	20.96	21.50	0	20.92		
		50% RB High	38 Pos 39	21.50	0	20.90	21.50	0	20.93		
		100% RB	75 Pos 0	21.50	0	20.74	21.50	0	20.97		
		1RB Low	1 Pos 0	21.50	0	21.01	21.50	0	21.18		
		1RB Mid	1 Pos 38	21.50	0	20.90	21.50	0	21.09		
		1RB High	1 Pos 74	21.50	0	20.93	21.50	0	20.98		
		50% RB Low	38 Pos 0	21.50	0	21.00	21.50	0	21.03		
		50% RB Mid	38 Pos 19	21.50	0	20.88	21.50	0	20.92		
		50% RB High	38 Pos 39	21.50	0	20.90	21.50	0	20.86		
		100% RB	75 Pos 0	21.50	0	20.88	21.50	0	20.86		
		1RB Low	1 Pos 0	21.50	0	20.99	21.50	0	21.10		
		1RB Mid	1 Pos 24	21.50	0	21.01	21.50	0	21.17		
		1RB High	1 Pos 49	21.50	0	20.93	21.50	0	20.93		
	50% RB Low	25 Pos 0	21.50	0	21.02	21.50	0	21.02			
	50% RB Mid	25 Pos 12	21.50	0	20.97	21.50	0	21.01			
	50% RB High	25 Pos 24	21.50	0	20.85	21.50	0	20.87			
	100% RB	50 Pos 0	21.50	0	21.01	21.50	0	21.02			
	1RB Low	1 Pos 0	21.50	0	21.00	21.50	0	21.14			
	1RB Mid	1 Pos 24	21.50	0	20.93	21.50	0	21.05			
	1RB High	1 Pos 49	21.50	0	21.04	21.50	0	21.20			
	50% RB Low	25 Pos 0	21.50	0	20.91	21.50	0	20.92			
	50% RB Mid	25 Pos 12	21.50	0	20.94	21.50	0	20.90			
	50% RB High	25 Pos 24	21.50	0	20.97	21.50	0	20.95			
	100% RB	50 Pos 0	21.50	0	20.93	21.50	0	20.98			
	1RB Low	1 Pos 0	21.50	0	20.98	21.50	0	21.10			
	1RB Mid	1 Pos 24	21.50	0	20.86	21.50	0	20.98			
	1RB High	1 Pos 49	21.50	0	20.93	21.50	0	21.06			
	50% RB Low	25 Pos 0	21.50	0	20.89	21.50	0	20.85			
	50% RB Mid	25 Pos 12	21.50	0	20.82	21.50	0	20.79			
	50% RB High	25 Pos 24	21.50	0	20.83	21.50	0	20.80			
	100% RB	50 Pos 0	21.50	0	20.83	21.50	0	20.81			
	1RB Low	1 Pos 0	21.50	0	21.04	21.50	0	21.13			
	1RB Mid	1 Pos 12	21.50	0	20.98	21.50	0	21.17			
	1RB High	1 Pos 24	21.50	0	21.10	21.50	0	21.32			
	50% RB Low	12 Pos 0	21.50	0	20.90	21.50	0	20.90			
	50% RB Mid	12 Pos 6	21.50	0	20.92	21.50	0	20.99			
	50% RB High	12 Pos 11	21.50	0	20.93	21.50	0	20.97			
	100% RB	25 Pos 0	21.50	0	20.96	21.50	0	20.95			
	1RB Low	1 Pos 0	21.50	0	20.94	21.50	0	21.16			
	1RB Mid	1 Pos 12	21.50	0	20.98	21.50	0	21.08			
	1RB High	1 Pos 24	21.50	0	21.00	21.50	0	21.29			
	50% RB Low	12 Pos 0	21.50	0	20.89	21.50	0	20.89			
	50% RB Mid	12 Pos 6	21.50	0	20.90	21.50	0	20.91			
	50% RB High	12 Pos 11	21.50	0	20.98	21.50	0	20.98			
	100% RB	25 Pos 0	21.50	0	20.92	21.50	0	20.95			
	1RB Low	1 Pos 0	21.50	0	20.92	21.50	0	21.14			
	1RB Mid	1 Pos 12	21.50	0	20.89	21.50	0	21.00			
	1RB High	1 Pos 24	21.50	0	20.91	21.50	0	20.85			
	50% RB Low	12 Pos 0	21.50	0	20.86	21.50	0	20.85			
	50% RB Mid	12 Pos 6	21.50	0	20.76	21.50	0	20.84			
	50% RB High	12 Pos 11	21.50	0	20.79	21.50	0	20.81			
	100% RB	25 Pos 0	21.50	0	20.88	21.50	0	20.85			

Band	BW	Channel #	Freq (MHz)	% RB Allocation	RB Position	QPSK			16 QAM		
						Factory Upper Tolerance (dBm)	M P R	Measured Output Power (dBm)	Factory Upper Tolerance (dBm)	M P R	Measured Output Power (dBm)
LTE26	3.0 MHz	26705	815.5	1RB Low	1 Pos 0	21.50	0	20.98	21.50	0	20.99
				1RB Mid	1 Pos 7	21.50	0	20.95	21.50	0	20.98
				1RB High	1 Pos 14	21.50	0	20.95	21.50	0	21.04
				50% RB Low	8 Pos 0	21.50	0	20.94	21.50	0	20.92
				50% RB Mid	8 Pos 4	21.50	0	20.91	21.50	0	20.88
				50% RB High	8 Pos 7	21.50	0	20.99	21.50	0	21.06
		100% RB	15 Pos 0	21.50	0	20.95	21.50	0	20.93		
		26865	831.5	1RB Low	1 Pos 0	21.50	0	20.90	21.50	0	20.94
				1RB Mid	1 Pos 7	21.50	0	20.98	21.50	0	21.18
				1RB High	1 Pos 14	21.50	0	20.98	21.50	0	21.07
				50% RB Low	8 Pos 0	21.50	0	20.98	21.50	0	20.99
				50% RB Mid	8 Pos 4	21.50	0	20.97	21.50	0	21.03
				50% RB High	8 Pos 7	21.50	0	21.04	21.50	0	21.02
		100% RB	15 Pos 0	21.50	0	20.98	21.50	0	20.96		
		27025	847.5	1RB Low	1 Pos 0	21.50	0	20.81	21.50	0	20.76
				1RB Mid	1 Pos 7	21.50	0	20.84	21.50	0	20.98
				1RB High	1 Pos 14	21.50	0	20.83	21.50	0	21.11
				50% RB Low	8 Pos 0	21.50	0	20.84	21.50	0	20.92
	50% RB Mid			8 Pos 4	21.50	0	20.84	21.50	0	20.86	
	50% RB High			8 Pos 7	21.50	0	20.91	21.50	0	20.99	
	100% RB	15 Pos 0	21.50	0	20.86	21.50	0	20.87			
	1.4 MHz	26697	814.7	1RB Low	1 Pos 0	21.50	0	21.00	21.50	0	21.12
				1RB Mid	1 Pos 2	21.50	0	21.00	21.50	0	21.02
				1RB High	1 Pos 5	21.50	0	20.99	21.50	0	21.05
				50% RB Low	3 Pos 0	21.50	0	20.95	21.50	0	20.99
				50% RB Mid	3 Pos 1	21.50	0	20.93	21.50	0	21.01
				50% RB High	3 Pos 2	21.50	0	20.92	21.50	0	20.96
		100% RB	6 Pos 0	21.50	0	20.93	21.50	0	20.99		
		26865	831.5	1RB Low	1 Pos 0	21.50	0	20.99	21.50	0	21.26
				1RB Mid	1 Pos 2	21.50	0	20.94	21.50	0	20.96
				1RB High	1 Pos 5	21.50	0	20.98	21.50	0	21.14
				50% RB Low	3 Pos 0	21.50	0	20.95	21.50	0	21.08
				50% RB Mid	3 Pos 1	21.50	0	20.94	21.50	0	21.02
				50% RB High	3 Pos 2	21.50	0	20.96	21.50	0	21.01
		100% RB	6 Pos 0	21.50	0	20.94	21.50	0	21.06		
		27033	848.3	1RB Low	1 Pos 0	21.50	0	20.86	21.50	0	20.98
				1RB Mid	1 Pos 2	21.50	0	20.91	21.50	0	20.80
				1RB High	1 Pos 5	21.50	0	20.89	21.50	0	21.05
				50% RB Low	3 Pos 0	21.50	0	20.90	21.50	0	20.90
	50% RB Mid			3 Pos 1	21.50	0	20.91	21.50	0	21.06	
	50% RB High			3 Pos 2	21.50	0	20.91	21.50	0	20.94	
	100% RB	6 Pos 0	21.50	0	20.88	21.50	0	20.89			

**B.2.2.11 LTE Band 30 FDD**

Band	BW	Channel #	Freq (MHz)	% RB Allocation	RB Position	QPSK			16 QAM		
						Factory Upper Tolerance (dBm)	M P R	Measured Output Power (dBm)	Factory Upper Tolerance (dBm)	M P R	Measured Output Power (dBm)
LTE30	10 MHz	27710	2310	1RB Low	1 Pos 0	17.50	0	16.48	17.50	0	16.68
				1RB Mid	1 Pos 24	17.50	0	16.56	17.50	0	16.85
				1RB High	1 Pos 49	17.50	0	16.62	17.50	0	16.67
				50% RB Low	25 Pos 0	17.50	0	16.45	17.50	0	16.47
				50% RB Mid	25 Pos 12	17.50	0	16.53	17.50	0	16.59
				50% RB High	25 Pos 24	17.50	0	16.59	17.50	0	16.62
				100% RB	50 Pos 0	17.50	0	16.63	17.50	0	16.64
	5.0 MHz	27710	2310	1RB Low	1 Pos 0	17.50	0	16.50	17.50	0	16.46
				1RB Mid	1 Pos 12	17.50	0	16.60	17.50	0	16.69
				1RB High	1 Pos 24	17.50	0	16.71	17.50	0	16.77
				50% RB Low	12 Pos 0	17.50	0	16.33	17.50	0	16.29
				50% RB Mid	12 Pos 6	17.50	0	16.40	17.50	0	16.39
				50% RB High	12 Pos 11	17.50	0	16.46	17.50	0	16.41
				100% RB	25 Pos 0	17.50	0	16.47	17.50	0	16.37

**B.2.2.12 LTE Band 41 TDD**

Band	BW	Channel #	Freq (MHz)	% RB Allocation	RB Position	QPSK			16 QAM		
						Factory Upper Tolerance (dBm)	M P R	Measured Output Power (dBm)	Factory Upper Tolerance (dBm)	M P R	Measured Output Power (dBm)
LTE41	20 MHz	39750	2506	1RB Low	1 Pos 0	16.00	0	15.67	16.00	0	15.72
				1RB Mid	1 Pos 50	16.00	0	15.64	16.00	0	15.95
				1RB High	1 Pos 99	16.00	0	15.57	16.00	0	15.68
				50% RB Low	50 Pos 0	16.00	0	15.53	16.00	0	15.55
				50% RB Mid	50 Pos 24	16.00	0	15.59	16.00	0	15.61
				50% RB High	50 Pos 50	16.00	0	15.57	16.00	0	15.57
		100% RB	100 Pos 0	16.00	0	15.62	16.00	0	15.63		
		40185	2549.5	1RB Low	1 Pos 0	16.00	0	15.40	16.00	0	15.67
				1RB Mid	1 Pos 50	16.00	0	15.38	16.00	0	15.62
				1RB High	1 Pos 99	16.00	0	15.57	16.00	0	15.73
				50% RB Low	50 Pos 0	16.00	0	15.37	16.00	0	15.39
				50% RB Mid	50 Pos 24	16.00	0	15.37	16.00	0	15.39
				50% RB High	50 Pos 50	16.00	0	15.38	16.00	0	15.41
		100% RB	100 Pos 0	16.00	0	15.39	16.00	0	15.44		
		40620	2593	1RB Low	1 Pos 0	16.00	0	15.44	16.00	0	15.65
				1RB Mid	1 Pos 50	16.00	0	15.26	16.00	0	15.43
				1RB High	1 Pos 99	16.00	0	15.24	16.00	0	15.42
				50% RB Low	50 Pos 0	16.00	0	15.30	16.00	0	15.33
				50% RB Mid	50 Pos 24	16.00	0	15.24	16.00	0	15.46
				50% RB High	50 Pos 50	16.00	0	15.19	16.00	0	15.42
		100% RB	100 Pos 0	16.00	0	15.28	16.00	0	15.40		
		41055	2636.5	1RB Low	1 Pos 0	16.00	0	15.47	16.00	0	15.79
				1RB Mid	1 Pos 50	16.00	0	15.54	16.00	0	15.61
				1RB High	1 Pos 99	16.00	0	15.58	16.00	0	15.67
				50% RB Low	50 Pos 0	16.00	0	15.55	16.00	0	15.58
				50% RB Mid	50 Pos 24	16.00	0	15.56	16.00	0	15.56
				50% RB High	50 Pos 50	16.00	0	15.54	16.00	0	15.54
		100% RB	100 Pos 0	16.00	0	15.57	16.00	0	15.59		
		41490	2680	1RB Low	1 Pos 0	16.00	0	15.53	16.00	0	15.68
				1RB Mid	1 Pos 50	16.00	0	15.47	16.00	0	15.46
				1RB High	1 Pos 99	16.00	0	15.55	16.00	0	15.81
				50% RB Low	50 Pos 0	16.00	0	15.45	16.00	0	15.45
				50% RB Mid	50 Pos 24	16.00	0	15.44	16.00	0	15.44
				50% RB High	50 Pos 50	16.00	0	15.51	16.00	0	15.51
		100% RB	100 Pos 0	16.00	0	15.50	16.00	0	15.51		



Band	BW	Channel #	Freq (MHz)	% RB Allocation	RB Position	QPSK			16 QAM		
						Factory Upper Tolerance (dBm)	M P R	Measured Output Power (dBm)	Factory Upper Tolerance (dBm)	M P R	Measured Output Power (dBm)
LTE41	15 MHz	39750	2506	1RB Low	1 Pos 0	16.00	0	15.60	16.00	0	15.81
				1RB Mid	1 Pos 38	16.00	0	15.63	16.00	0	15.88
				1RB High	1 Pos 74	16.00	0	15.56	16.00	0	15.91
				50% RB Low	38 Pos 0	16.00	0	15.56	16.00	0	15.58
				50% RB Mid	38 Pos 19	16.00	0	15.61	16.00	0	15.62
				50% RB High	38 Pos 39	16.00	0	15.56	16.00	0	15.58
		40185	2549.5	100% RB	75 Pos 0	16.00	0	15.59	16.00	0	15.56
				1RB Low	1 Pos 0	16.00	0	15.41	16.00	0	15.63
				1RB Mid	1 Pos 38	16.00	0	15.36	16.00	0	15.77
				1RB High	1 Pos 74	16.00	0	15.40	16.00	0	15.45
				50% RB Low	38 Pos 0	16.00	0	15.37	16.00	0	15.38
				50% RB Mid	38 Pos 19	16.00	0	15.37	16.00	0	15.46
		40620	2593	50% RB High	38 Pos 39	16.00	0	15.37	16.00	0	15.38
				100% RB	75 Pos 0	16.00	0	15.40	16.00	0	15.43
				1RB Low	1 Pos 0	16.00	0	15.39	16.00	0	15.53
				1RB Mid	1 Pos 38	16.00	0	15.33	16.00	0	15.35
				1RB High	1 Pos 74	16.00	0	15.26	16.00	0	15.38
				50% RB Low	38 Pos 0	16.00	0	15.29	16.00	0	15.34
		41055	2636.5	50% RB Mid	38 Pos 19	16.00	0	15.25	16.00	0	15.28
				50% RB High	38 Pos 39	16.00	0	15.22	16.00	0	15.26
				100% RB	75 Pos 0	16.00	0	15.29	16.00	0	15.29
				1RB Low	1 Pos 0	16.00	0	15.56	16.00	0	15.89
				1RB Mid	1 Pos 38	16.00	0	15.59	16.00	0	15.66
				1RB High	1 Pos 74	16.00	0	15.53	16.00	0	15.75
		41490	2680.0	50% RB Low	38 Pos 0	16.00	0	15.58	16.00	0	15.59
				50% RB Mid	38 Pos 19	16.00	0	15.58	16.00	0	15.60
				50% RB High	38 Pos 39	16.00	0	15.54	16.00	0	15.54
				100% RB	75 Pos 0	16.00	0	15.57	16.00	0	15.59
				1RB Low	1 Pos 0	16.00	0	15.45	16.00	0	15.49
				1RB Mid	1 Pos 38	16.00	0	15.43	16.00	0	15.68
		41490	2680.0	1RB High	1 Pos 74	16.00	0	15.41	16.00	0	15.46
				50% RB Low	38 Pos 0	16.00	0	15.44	16.00	0	15.45
				50% RB Mid	38 Pos 19	16.00	0	15.43	16.00	0	15.47
				50% RB High	38 Pos 39	16.00	0	15.50	16.00	0	15.52
				100% RB	75 Pos 0	16.00	0	15.47	16.00	0	15.45

Band	BW	Channel #	Freq (MHz)	% RB Allocation	RB Position	QPSK			16 QAM		
						Factory Upper Tolerance (dBm)	M P R	Measured Output Power (dBm)	Factory Upper Tolerance (dBm)	M P R	Measured Output Power (dBm)
LTE41	10 MHz	39750	2506	1RB Low	1 Pos 0	16.00	0	15.63	16.00	0	15.67
				1RB Mid	1 Pos 24	16.00	0	15.64	16.00	0	15.75
				1RB High	1 Pos 49	16.00	0	15.64	16.00	0	15.87
				50% RB Low	25 Pos 0	16.00	0	15.50	16.00	0	15.57
				50% RB Mid	25 Pos 12	16.00	0	15.57	16.00	0	15.63
				50% RB High	25 Pos 24	16.00	0	15.54	16.00	0	15.59
		40185	2549.5	100% RB	50 Pos 0	16.00	0	15.59	16.00	0	15.60
				1RB Low	1 Pos 0	16.00	0	15.38	16.00	0	15.55
				1RB Mid	1 Pos 24	16.00	0	15.40	16.00	0	15.60
				1RB High	1 Pos 49	16.00	0	15.43	16.00	0	15.45
				50% RB Low	25 Pos 0	16.00	0	15.38	16.00	0	15.43
				50% RB Mid	25 Pos 12	16.00	0	15.36	16.00	0	15.39
		40620	2593	50% RB High	25 Pos 24	16.00	0	15.41	16.00	0	15.45
				100% RB	50 Pos 0	16.00	0	15.36	16.00	0	15.40
				1RB Low	1 Pos 0	16.00	0	15.33	16.00	0	15.51
				1RB Mid	1 Pos 24	16.00	0	15.29	16.00	0	15.28
				1RB High	1 Pos 49	16.00	0	15.23	16.00	0	15.37
				50% RB Low	25 Pos 0	16.00	0	15.26	16.00	0	15.32
		41055	2636.5	50% RB Mid	25 Pos 12	16.00	0	15.22	16.00	0	15.24
				100% RB	50 Pos 0	16.00	0	15.21	16.00	0	15.27
				1RB Low	1 Pos 0	16.00	0	15.25	16.00	0	15.29
				1RB Mid	1 Pos 24	16.00	0	15.61	16.00	0	15.78
				1RB High	1 Pos 49	16.00	0	15.56	16.00	0	15.88
				50% RB Low	25 Pos 0	16.00	0	15.55	16.00	0	15.52
		41490	2680	50% RB Mid	25 Pos 12	16.00	0	15.59	16.00	0	15.61
				100% RB	50 Pos 0	16.00	0	15.55	16.00	0	15.58
				1RB Low	1 Pos 0	16.00	0	15.61	16.00	0	15.62
				1RB Mid	1 Pos 24	16.00	0	15.58	16.00	0	15.58
				1RB High	1 Pos 49	16.00	0	15.42	16.00	0	15.34
				50% RB Low	25 Pos 0	16.00	0	15.40	16.00	0	15.47
				50% RB Mid	25 Pos 12	16.00	0	15.58	16.00	0	15.61
				100% RB	50 Pos 0	16.00	0	15.46	16.00	0	15.45
				1RB Low	1 Pos 0	16.00	0	15.41	16.00	0	15.44
				1RB Mid	1 Pos 24	16.00	0	15.51	16.00	0	15.50
				1RB High	1 Pos 49	16.00	0	15.42	16.00	0	15.43

Band	BW	Channel #	Freq (MHz)	% RB Allocation	RB Position	QPSK			16 QAM		
						Factory Upper Tolerance (dBm)	M P R	Measured Output Power (dBm)	Factory Upper Tolerance (dBm)	M P R	Measured Output Power (dBm)
LTE41	5.0 MHz	39750	2506	1RB Low	1 Pos 0	16.00	0	15.56	16.00	0	15.77
				1RB Mid	1 Pos 12	16.00	0	15.58	16.00	0	15.93
				1RB High	1 Pos 24	16.00	0	15.61	16.00	0	15.82
				50% RB Low	12 Pos 0	16.00	0	15.48	16.00	0	15.45
				50% RB Mid	12 Pos 6	16.00	0	15.50	16.00	0	15.54
				50% RB High	12 Pos 11	16.00	0	15.52	16.00	0	15.52
		40185	2549.5	100% RB	25 Pos 0	16.00	0	15.52	16.00	0	15.50
				1RB Low	1 Pos 0	16.00	0	15.43	16.00	0	15.61
				1RB Mid	1 Pos 12	16.00	0	15.38	16.00	0	15.37
				1RB High	1 Pos 24	16.00	0	15.54	16.00	0	15.85
				50% RB Low	12 Pos 0	16.00	0	15.28	16.00	0	15.29
				50% RB Mid	12 Pos 6	16.00	0	15.28	16.00	0	15.28
		40620	2593	50% RB High	12 Pos 11	16.00	0	15.31	16.00	0	15.34
				100% RB	25 Pos 0	16.00	0	15.32	16.00	0	15.31
				1RB Low	1 Pos 0	16.00	0	15.29	16.00	0	15.37
				1RB Mid	1 Pos 12	16.00	0	15.24	16.00	0	15.37
				1RB High	1 Pos 24	16.00	0	15.32	16.00	0	15.29
				50% RB Low	12 Pos 0	16.00	0	15.17	16.00	0	15.22
		41055	2636.5	50% RB Mid	12 Pos 6	16.00	0	15.15	16.00	0	15.13
				50% RB High	12 Pos 11	16.00	0	15.17	16.00	0	15.21
				100% RB	25 Pos 0	16.00	0	15.18	16.00	0	15.17
				1RB Low	1 Pos 0	16.00	0	15.55	16.00	0	15.64
				1RB Mid	1 Pos 12	16.00	0	15.53	16.00	0	15.65
				1RB High	1 Pos 24	16.00	0	15.61	16.00	0	15.88
		41490	2680	50% RB Low	12 Pos 0	16.00	0	15.51	16.00	0	15.55
				50% RB Mid	12 Pos 6	16.00	0	15.45	16.00	0	15.43
				50% RB High	12 Pos 11	16.00	0	15.47	16.00	0	15.46
				100% RB	25 Pos 0	16.00	0	15.47	16.00	0	15.45
				1RB Low	1 Pos 0	16.00	0	15.39	16.00	0	15.47
				1RB Mid	1 Pos 12	16.00	0	15.34	16.00	0	15.39
				1RB High	1 Pos 24	16.00	0	15.47	16.00	0	15.43
				50% RB Low	12 Pos 0	16.00	0	15.28	16.00	0	15.25
				50% RB Mid	12 Pos 6	16.00	0	15.32	16.00	0	15.34
				50% RB High	12 Pos 11	16.00	0	15.33	16.00	0	15.32
				100% RB	25 Pos 0	16.00	0	15.35	16.00	0	15.33

**B.2.2.13 LTE Band 48 TDD**

Band	BW	Channel #	Freq (MHz)	% RB Allocation	RB Position	QPSK			16 QAM		
						Factory Upper Tolerance (dBm)	M P R	Measured Output Power (dBm)	Factory Upper Tolerance (dBm)	M P R	Measured Output Power (dBm)
LTE 48	20 MHz	55340	3560	1RB Low	1 Pos 0	18.00	0	17.38	18.00	0	16.88
				1RB Mid	1 Pos 50	18.00	0	17.30	18.00	0	16.83
				1RB High	1 Pos 99	18.00	0	17.36	18.00	0	16.85
				50% RB Low	50 Pos 0	18.00	0	16.80	18.00	0	16.38
				50% RB Mid	50 Pos 24	18.00	0	16.83	18.00	0	16.75
				50% RB High	50 Pos 50	18.00	0	16.82	18.00	0	16.79
		100% RB	100 Pos 0	18.00	0	16.82	18.00	0	16.77		
		55990	3625	1RB Low	1 Pos 0	18.00	0	17.17	18.00	0	16.65
				1RB Mid	1 Pos 50	18.00	0	17.10	18.00	0	16.62
				1RB High	1 Pos 99	18.00	0	17.16	18.00	0	16.67
				50% RB Low	50 Pos 0	18.00	0	16.70	18.00	0	16.65
				50% RB Mid	50 Pos 24	18.00	0	16.67	18.00	0	16.58
				50% RB High	50 Pos 50	18.00	0	16.70	18.00	0	16.59
		100% RB	100 Pos 0	18.00	0	16.62	18.00	0	16.61		
		56640	3690	1RB Low	1 Pos 0	18.00	0	17.09	18.00	0	16.50
				1RB Mid	1 Pos 50	18.00	0	17.20	18.00	0	16.58
				1RB High	1 Pos 99	18.00	0	17.28	18.00	0	16.71
				50% RB Low	50 Pos 0	18.00	0	16.62	18.00	0	16.55
	50% RB Mid			50 Pos 24	18.00	0	16.61	18.00	0	16.55	
	50% RB High			50 Pos 50	18.00	0	16.70	18.00	0	16.66	
	100% RB	100 Pos 0	18.00	0	16.63	18.00	0	16.56			
	15 MHz	55315	3557.5	1RB Low	1 Pos 0	18.00	0	17.20	18.00	0	16.75
				1RB Mid	1 Pos 38	18.00	0	17.07	18.00	0	16.75
				1RB High	1 Pos 74	18.00	0	17.22	18.00	0	16.77
				50% RB Low	38 Pos 0	18.00	0	16.82	18.00	0	16.75
				50% RB Mid	38 Pos 19	18.00	0	16.68	18.00	0	16.72
				50% RB High	38 Pos 39	18.00	0	16.83	18.00	0	16.76
		100% RB	75 Pos 0	18.00	0	16.75	18.00	0	16.70		
		55990	3625	1RB Low	1 Pos 0	18.00	0	17.08	18.00	0	16.68
				1RB Mid	1 Pos 38	18.00	0	17.10	18.00	0	16.65
				1RB High	1 Pos 74	18.00	0	17.10	18.00	0	16.68
				50% RB Low	38 Pos 0	18.00	0	16.73	18.00	0	16.63
				50% RB Mid	38 Pos 19	18.00	0	16.74	18.00	0	16.67
				50% RB High	38 Pos 39	18.00	0	16.65	18.00	0	16.62
		100% RB	75 Pos 0	18.00	0	16.62	18.00	0	16.56		
		56665	3692.5	1RB Low	1 Pos 0	18.00	0	17.10	18.00	0	16.61
				1RB Mid	1 Pos 38	18.00	0	17.27	18.00	0	16.78
				1RB High	1 Pos 74	18.00	0	17.23	18.00	0	16.78
				50% RB Low	38 Pos 0	18.00	0	16.63	18.00	0	16.55
	50% RB Mid			38 Pos 19	18.00	0	16.74	18.00	0	16.63	
	50% RB High			38 Pos 39	18.00	0	16.77	18.00	0	16.67	
	100% RB	75 Pos 0	18.00	0	16.71	18.00	0	16.64			
	10 MHz	55290	3555	1RB Low	1 Pos 0	18.00	0	17.19	18.00	0	16.85
				1RB Mid	1 Pos 24	18.00	0	17.08	18.00	0	16.78
				1RB High	1 Pos 49	18.00	0	17.20	18.00	0	16.86
				50% RB Low	25 Pos 0	18.00	0	16.78	18.00	0	16.73
				50% RB Mid	25 Pos 12	18.00	0	16.76	18.00	0	16.72
				50% RB High	25 Pos 25	18.00	0	16.80	18.00	0	16.71
		100% RB	50 Pos0	18.00	0	16.75	18.00	0	16.69		
		55990	3625	1RB Low	1 Pos 0	18.00	0	17.13	18.00	0	16.72
				1RB Mid	1 Pos 24	18.00	0	17.15	18.00	0	16.75
				1RB High	1 Pos 49	18.00	0	17.12	18.00	0	16.73
				50% RB Low	25 Pos 0	18.00	0	16.70	18.00	0	16.62
				50% RB Mid	25 Pos 12	18.00	0	16.68	18.00	0	16.61
				50% RB High	25 Pos 25	18.00	0	16.63	18.00	0	16.56
		100% RB	50 Pos0	18.00	0	16.60	18.00	0	16.54		
		56690	3695	1RB Low	1 Pos 0	18.00	0	17.11	18.00	0	16.65
				1RB Mid	1 Pos 24	18.00	0	17.20	18.00	0	16.76
				1RB High	1 Pos 49	18.00	0	17.23	18.00	0	16.80
				50% RB Low	25 Pos 0	18.00	0	16.77	18.00	0	16.68
50% RB Mid	25 Pos 12			18.00	0	16.78	18.00	0	16.70		
50% RB High	25 Pos 25			18.00	0	16.75	18.00	0	16.65		
100% RB	50 Pos0	18.00	0	16.75	18.00	0	16.68				

Band	BW	Channel #	Freq (MHz)	% RB Allocation	RB Position	QPSK			16 QAM		
						Factory Upper Tolerance (dBm)	M P R	Measured Output Power (dBm)	Factory Upper Tolerance (dBm)	M P R	Measured Output Power (dBm)
LTE 48	5 MHz	55265	3552.5	1RB Low	1 Pos 0	18.00	0	17.40	18.00	0	16.85
				1RB Mid	1 Pos 12	18.00	0	17.38	18.00	0	16.77
				1RB High	1 Pos 24	18.00	0	17.32	18.00	0	16.80
				50% RB Low	12 Pos 0	18.00	0	16.45	18.00	0	16.46
				50% RB Mid	12 Pos 6	18.00	0	16.38	18.00	0	16.36
				50% RB High	12 Pos 11	18.00	0	16.41	18.00	0	16.38
		55990	3625	100% RB	25 Pos 0	18.00	0	16.37	18.00	0	16.45
				1RB Low	1 Pos 0	18.00	0	17.00	18.00	0	16.65
				1RB Mid	1 Pos 12	18.00	0	16.90	18.00	0	16.53
				1RB High	1 Pos 24	18.00	0	17.02	18.00	0	16.57
				50% RB Low	12 Pos 0	18.00	0	16.40	18.00	0	16.38
				50% RB Mid	12 Pos 6	18.00	0	16.37	18.00	0	16.35
		56715	3697.5	50% RB High	12 Pos 11	18.00	0	16.34	18.00	0	16.32
				100% RB	25 Pos 0	18.00	0	16.26	18.00	0	16.36
				1RB Low	1 Pos 0	18.00	0	17.33	18.00	0	16.77
				1RB Mid	1 Pos 12	18.00	0	17.36	18.00	0	16.74
				1RB High	1 Pos 24	18.00	0	17.33	18.00	0	16.78
				50% RB Low	12 Pos 0	18.00	0	16.47	18.00	0	16.43
		50% RB Mid	12 Pos 6	18.00	0	16.45	18.00	0	16.41		
		50% RB High	12 Pos 11	18.00	0	16.46	18.00	0	16.42		
		100% RB	25 Pos 0	18.00	0	16.47	18.00	0	16.49		

**B.2.2.14 LTE Band 66 FDD**

Band	BW	Channel #	Freq (MHz)	% RB Allocation	RB Position	QPSK			16 QAM		
						Factory Upper Tolerance (dBm)	M P R	Measured Output Power (dBm)	Factory Upper Tolerance (dBm)	M P R	Measured Output Power (dBm)
LTE66	20 MHz	132072	1720	1RB Low	1 Pos 0	17.50	0	16.88	17.50	0	17.13
				1RB Mid	1 Pos 50	17.50	0	16.99	17.50	0	17.20
				1RB High	1 Pos 99	17.50	0	16.81	17.50	0	16.96
				50% RB Low	50 Pos 0	17.50	0	17.03	17.50	0	17.11
				50% RB Mid	50 Pos 24	17.50	0	16.97	17.50	0	17.05
				50% RB High	50 Pos 50	17.50	0	16.90	17.50	0	16.93
		100% RB	100 Pos 0	17.50	0	16.90	17.50	0	16.97		
		132322	1745	1RB Low	1 Pos 0	17.50	0	16.97	17.50	0	17.22
				1RB Mid	1 Pos 50	17.50	0	16.85	17.50	0	17.15
				1RB High	1 Pos 99	17.50	0	16.56	17.50	0	16.86
				50% RB Low	50 Pos 0	17.50	0	16.87	17.50	0	16.90
				50% RB Mid	50 Pos 24	17.50	0	16.82	17.50	0	16.86
				50% RB High	50 Pos 50	17.50	0	16.74	17.50	0	16.75
		100% RB	100 Pos 0	17.50	0	16.82	17.50	0	16.90		
		132572	1770	1RB Low	1 Pos 0	17.50	0	16.74	17.50	0	16.83
				1RB Mid	1 Pos 50	17.50	0	16.61	17.50	0	16.64
				1RB High	1 Pos 99	17.50	0	16.77	17.50	0	16.85
				50% RB Low	50 Pos 0	17.50	0	16.57	17.50	0	16.56
	50% RB Mid			50 Pos 24	17.50	0	16.65	17.50	0	16.66	
	50% RB High			50 Pos 50	17.50	0	16.71	17.50	0	16.73	
	100% RB	100 Pos 0	17.50	0	16.81	17.50	0	16.80			
	15 MHz	132047	1717.5	1RB Low	1 Pos 0	17.50	0	16.83	17.50	0	16.98
				1RB Mid	1 Pos 38	17.50	0	16.98	17.50	0	17.28
				1RB High	1 Pos 74	17.50	0	16.88	17.50	0	17.03
				50% RB Low	38 Pos 0	17.50	0	16.90	17.50	0	16.97
				50% RB Mid	38 Pos 19	17.50	0	16.93	17.50	0	17.00
				50% RB High	38 Pos 39	17.50	0	16.92	17.50	0	16.98
		100% RB	75 Pos 0	17.50	0	17.00	17.50	0	16.98		
		132422	1755	1RB Low	1 Pos 0	17.50	0	16.81	17.50	0	17.05
				1RB Mid	1 Pos 38	17.50	0	16.86	17.50	0	17.12
				1RB High	1 Pos 74	17.50	0	16.67	17.50	0	16.71
				50% RB Low	38 Pos 0	17.50	0	16.81	17.50	0	16.82
				50% RB Mid	38 Pos 19	17.50	0	16.82	17.50	0	16.84
				50% RB High	38 Pos 39	17.50	0	16.76	17.50	0	16.71
		100% RB	75 Pos 0	17.50	0	16.81	17.50	0	16.83		
		132597	1772.5	1RB Low	1 Pos 0	17.50	0	16.57	17.50	0	16.87
				1RB Mid	1 Pos 38	17.50	0	16.71	17.50	0	16.77
				1RB High	1 Pos 74	17.50	0	16.78	17.50	0	17.05
				50% RB Low	38 Pos 0	17.50	0	16.58	17.50	0	16.59
	50% RB Mid			38 Pos 19	17.50	0	16.65	17.50	0	16.74	
	50% RB High			38 Pos 39	17.50	0	16.73	17.50	0	16.76	
	100% RB	75 Pos 0	17.50	0	16.74	17.50	0	16.77			
	10 MHz	132022	1715	1RB Low	1 Pos 0	17.50	0	16.83	17.50	0	16.80
				1RB Mid	1 Pos 24	17.50	0	16.93	17.50	0	17.11
				1RB High	1 Pos 49	17.50	0	16.96	17.50	0	17.14
				50% RB Low	25 Pos 0	17.50	0	16.90	17.50	0	16.94
				50% RB Mid	25 Pos 12	17.50	0	16.96	17.50	0	16.99
				50% RB High	25 Pos 24	17.50	0	16.97	17.50	0	17.01
		100% RB	50 Pos 0	17.50	0	16.93	17.50	0	16.97		
		132422	1755	1RB Low	1 Pos 0	17.50	0	16.93	17.50	0	17.06
				1RB Mid	1 Pos 24	17.50	0	16.82	17.50	0	16.96
				1RB High	1 Pos 49	17.50	0	16.84	17.50	0	17.04
				50% RB Low	25 Pos 0	17.50	0	16.80	17.50	0	16.80
				50% RB Mid	25 Pos 12	17.50	0	16.79	17.50	0	16.82
				50% RB High	25 Pos 24	17.50	0	16.79	17.50	0	16.79
		100% RB	50 Pos 0	17.50	0	16.77	17.50	0	16.80		
		132622	1775	1RB Low	1 Pos 0	17.50	0	16.72	17.50	0	16.88
				1RB Mid	1 Pos 24	17.50	0	16.74	17.50	0	16.89
				1RB High	1 Pos 49	17.50	0	16.76	17.50	0	16.91
				50% RB Low	25 Pos 0	17.50	0	16.64	17.50	0	16.65
50% RB Mid	25 Pos 12			17.50	0	16.67	17.50	0	16.70		
50% RB High	25 Pos 24			17.50	0	16.67	17.50	0	16.73		
100% RB	50 Pos 0	17.50	0	16.69	17.50	0	16.75				

Band	BW	Channel #	Freq (MHz)	% RB Allocation	RB Position	QPSK			16 QAM			
						Factory Upper Tolerance (dBm)	M P R	Measured Output Power (dBm)	Factory Upper Tolerance (dBm)	M P R	Measured Output Power (dBm)	
LTE66	5.0 MHz	131997	1712.5	1RB Low	1 Pos 0	17.50	0	16.87	17.50	0	16.94	
				1RB Mid	1 Pos 12	17.50	0	16.96	17.50	0	17.11	
				1RB High	1 Pos 24	17.50	0	17.02	17.50	0	17.19	
				50% RB Low	12 Pos 0	17.50	0	16.77	17.50	0	16.83	
				50% RB Mid	12 Pos 6	17.50	0	16.84	17.50	0	16.88	
				50% RB High	12 Pos 11	17.50	0	16.89	17.50	0	16.98	
		132422	1755	100% RB	25 Pos 0	17.50	0	16.90	17.50	0	16.93	
				1RB Low	1 Pos 0	17.50	0	16.85	17.50	0	17.08	
				1RB Mid	1 Pos 12	17.50	0	16.83	17.50	0	17.07	
				1RB High	1 Pos 24	17.50	0	16.89	17.50	0	17.07	
				50% RB Low	12 Pos 0	17.50	0	16.81	17.50	0	16.82	
				50% RB Mid	12 Pos 6	17.50	0	16.79	17.50	0	16.77	
		132647	1777.5	50% RB High	12 Pos 11	17.50	0	16.84	17.50	0	16.90	
				100% RB	25 Pos 0	17.50	0	16.84	17.50	0	16.83	
				1RB Low	1 Pos 0	17.50	0	16.74	17.50	0	16.99	
				1RB Mid	1 Pos 12	17.50	0	16.71	17.50	0	16.74	
				1RB High	1 Pos 24	17.50	0	16.76	17.50	0	16.98	
				50% RB Low	12 Pos 0	17.50	0	16.72	17.50	0	16.68	
		3.0 MHz	131987	1711.5	50% RB Mid	12 Pos 6	17.50	0	16.67	17.50	0	16.67
					50% RB High	12 Pos 11	17.50	0	16.67	17.50	0	16.67
					100% RB	25 Pos 0	17.50	0	16.68	17.50	0	16.76
					1RB Low	1 Pos 0	17.50	0	16.81	17.50	0	17.18
					1RB Mid	1 Pos 7	17.50	0	16.80	17.50	0	17.29
					1RB High	1 Pos 14	17.50	0	16.85	17.50	0	16.95
			132422	1755	50% RB Low	8 Pos 0	17.50	0	16.79	17.50	0	16.84
					50% RB Mid	8 Pos 4	17.50	0	16.75	17.50	0	16.86
					50% RB High	8 Pos 7	17.50	0	16.88	17.50	0	16.94
					100% RB	15 Pos 0	17.50	0	16.80	17.50	0	16.87
					1RB Low	1 Pos 0	17.50	0	16.79	17.50	0	16.99
					1RB Mid	1 Pos 7	17.50	0	16.80	17.50	0	17.08
	132657		1778.5	1RB High	1 Pos 14	17.50	0	16.74	17.50	0	16.73	
				50% RB Low	8 Pos 0	17.50	0	16.80	17.50	0	16.85	
				50% RB Mid	8 Pos 4	17.50	0	16.83	17.50	0	16.86	
				50% RB High	8 Pos 7	17.50	0	16.86	17.50	0	16.90	
				100% RB	15 Pos 0	17.50	0	16.83	17.50	0	16.88	
				1RB Low	1 Pos 0	17.50	0	16.70	17.50	0	16.93	
	1.4 MHz		131979	1710	1RB Mid	1 Pos 7	17.50	0	16.72	17.50	0	17.20
					1RB High	1 Pos 14	17.50	0	16.69	17.50	0	16.82
					50% RB Low	8 Pos 0	17.50	0	16.72	17.50	0	16.78
					50% RB Mid	8 Pos 4	17.50	0	16.70	17.50	0	16.77
					50% RB High	8 Pos 7	17.50	0	16.73	17.50	0	16.78
					100% RB	15 Pos 0	17.50	0	16.71	17.50	0	16.79
			132422	1755	1RB Low	1 Pos 0	17.50	0	16.95	17.50	0	17.09
					1RB Mid	1 Pos 2	17.50	0	16.92	17.50	0	17.08
					1RB High	1 Pos 5	17.50	0	16.92	17.50	0	17.24
					50% RB Low	3 Pos 0	17.50	0	16.82	17.50	0	16.97
					50% RB Mid	3 Pos 1	17.50	0	16.84	17.50	0	17.01
					50% RB High	3 Pos 2	17.50	0	16.83	17.50	0	16.90
		132665	1779.3	100% RB	6 Pos 0	17.50	0	16.82	17.50	0	16.89	
				1RB Low	1 Pos 0	17.50	0	16.88	17.50	0	17.01	
				1RB Mid	1 Pos 2	17.50	0	16.90	17.50	0	17.04	
				1RB High	1 Pos 5	17.50	0	16.93	17.50	0	17.20	
				50% RB Low	3 Pos 0	17.50	0	16.85	17.50	0	16.99	
				50% RB Mid	3 Pos 1	17.50	0	16.85	17.50	0	17.01	
		132665	1779.3	50% RB High	3 Pos 2	17.50	0	16.89	17.50	0	17.06	
				100% RB	6 Pos 0	17.50	0	16.85	17.50	0	16.93	
				1RB Low	1 Pos 0	17.50	0	16.79	17.50	0	16.90	
				1RB Mid	1 Pos 2	17.50	0	16.80	17.50	0	16.92	
				1RB High	1 Pos 5	17.50	0	16.79	17.50	0	17.07	
				50% RB Low	3 Pos 0	17.50	0	16.75	17.50	0	16.85	
		132665	1779.3	50% RB Mid	3 Pos 1	17.50	0	16.77	17.50	0	16.84	
				50% RB High	3 Pos 2	17.50	0	16.79	17.50	0	16.90	
				100% RB	6 Pos 0	17.50	0	16.73	17.50	0	16.75	

## B.2.3 LTE UL Carrier Aggregation

### B.2.3.1 Intra-Band Contiguous

UL CA shall be tested based on the worst-case SAR configuration determined from non-CA SAR testing result. The UL CA mode power measurements represent the total power across both carriers.

According to November 2017 TCB workshop, the following needs to be performed: The maximum measured output power, RB allocation, CC offsets, CC channel BWs, MPR, modulation and other relevant information for all UL CA SAR configurations are required in SAR reports to support the test setup and results, including explanations, call box configurations and certain testing restriction

1) When the maximum output for UL CA is  $\leq$  standalone LTE mode

- The primary carrier is configured according to the highest standalone SAR configuration tested
- The secondary carrier and subsequent CCs are configured according to procedures used for power measurement and parameters similar to that used for the PCC

2) When the Reported SAR for UL CA configuration, is  $> 1.2$  W/kg, UL CA SAR is also required for all the other test channels

#### LTE CA 5B:

Band	Modulation / BW	PCC			SCC			Pwr Avg (dBm)	Factory Upper Tolerance (dBm)
		Ch	Freq (MHz)	RB Allocation	Ch	Freq (MHz)	RB Allocation		
LTE 5B	QPSK / 20MHz	26775	822.5	1RB High	20476	831.6	1RB Low	21.17	21.50

#### LTE CA 38C:

SAR Measurement for LTE Band 38 TDD (Frequency range: 2570 – 2620MHz) is covered by LTE Band 41 TDD (Frequency range: 2496 – 2690MHz) due to overlapping frequency range, same maximum tune-up and same bandwidth.

#### LTE CA 41C:

Band	Modulation / BW	PCC			SCC			Pwr Avg (dBm)	Factory Upper Tolerance (dBm)
		Ch	Freq (MHz)	RB Allocation	Ch	Freq (MHz)	RB Allocation		
LTE 41C	QPSK / 20MHz	40521	2583.1	1RB High	40719	2602.9	1RB Low	15.77	16.00

#### LTE CA 66B, 66C:

Band	Modulation / BW	PCC			SCC			Pwr Avg (dBm)	Factory Upper Tolerance (dBm)
		Ch	Freq (MHz)	RB Allocation	Ch	Freq (MHz)	RB Allocation		
LTE 66B	QPSK / 10MHz	132373	1750.1	1RB High	132472	1760	1RB Low	16.90	17.50
LTE 66C	QPSK / 20MHz	132323	1745.1	1RB High	132521	1764.9	1RB Low	17.10	17.50



### B.3 Tissue Parameters Measurement

#### Body TSL

Body TSL	Target TSL		Measured TSL		Deviation %		
Freq (MHz)	$\epsilon'$ (F/m)	$\sigma$ (S/m)	$\epsilon'$ (F/m)	$\sigma$ (S/m)	Deviation $\epsilon'$	Deviation $\sigma$	Date
750	55.53	0.96	53.92	0.92	-2.9	-4.17	2022-01-06
750	55.53	0.96	52.21	0.89	-5.98	-7.29	2022-01-27
835	55.19	0.98	52.03	0.92	-5.73	-6.12	2022-01-27
1750	53.43	1.49	52.06	1.48	-2.56	-0.67	2022-01-06
1750	53.43	1.49	50.55	1.39	-5.39	-6.71	2022-01-27
1900	53.3	1.52	50.55	1.49	-5.16	-1.97	2022-01-27
2300	52.9	1.81	49.98	1.83	-5.52	1.1	2022-01-27
2600	52.51	2.16	49.46	2.08	-5.81	-3.7	2022-01-27
3700	51.05	3.55	47.41	3.21	-7.13	-9.58	2022-01-27

See Annex D below for more details.

### B.4 System Check Measurements

#### Body Measurements

Frequency (MHz)	Average	Target SAR (W/kg)	Measured SAR (W/kg)	Deviation to target (%)	Limit (%)	Date
750	1g	8.75	8.23	-5.89	±10	2022-01-07
	10g	5.72	5.46	-4.52		2022-01-27
750	1g	8.75	8.26	-5.65		2022-01-28
	10g	5.72	5.40	-5.63		2022-01-28
835	1g	9.65	9.16	-5.08		2022-01-07
	10g	6.32	6.04	-4.43		2022-01-28
1750	1g	37.10	33.80	-8.89		2022-01-28
	10g	19.60	18.06	-7.86		2022-01-28
1750	1g	37.10	33.80	-8.89		2022-01-28
	10g	19.60	18.10	-7.65		2022-01-28
1900	1g	40.30	38.40	-4.71		2022-01-27
	10g	21.00	20.00	-4.76		2022-01-28
2300	1g	47.90	47.40	-1.04		2022-01-27
	10g	23.20	22.80	-1.72		2022-01-28
2600	1g	54.10	52.40	-3.14		2022-01-28
	10g	24.10	23.60	-2.07		2022-01-27
3700	1g	62.10	61.00	-1.77	2022-01-28	
	10g	22.20	22.60	1.80		

See Annex C for more details.

## B.5 SAR Test Results

### B.5.1 WCDMA

#### B.5.1.1 WCDMA II

Band	Antenna	BW (MHz)	Rate	Channel Number	Freq (MHz)	Position	Scaling Factor (dB)	Measured SAR 1g (W/Kg)	Reported SAR 1g (W/Kg)	Plot #
II	HongBo	5	RMC 12.2kbps	9400	1880	Laptop	0.45	0.62	0.69	1
	WNC	5	RMC 12.2kbps	9400	1880	Laptop	0.45	0.60	0.66	

#### B.5.1.2 WCDMA IV

Band	Antenna	BW (MHz)	Rate	Channel Number	Freq (MHz)	Position	Scaling Factor (dB)	Measured SAR 1g (W/Kg)	Reported SAR 1g (W/Kg)	Plot #
IV	HongBo	5	RMC 12.2kbps	1413	1732.6	Laptop	0.23	0.69	0.73	2
	WNC	5	RMC 12.2kbps	1413	1732.6	Laptop	0.23	0.67	0.70	

#### B.5.1.3 WCDMA V

Band	Antenna	BW (MHz)	Rate	Channel Number	Freq (MHz)	Position	Scaling Factor (dB)	Measured SAR 1g (W/Kg)	Reported SAR 1g (W/Kg)	Plot #
V	HongBo	5	RMC 12.2kbps	4132	826.6	Laptop	0.43	0.80	0.88	
				4183	836.6		0.42	0.85	0.93	3
				4233	846.6		0.42	0.85	0.93	
	WNC	5	RMC 12.2kbps	4132	826.6	Laptop	0.43	0.72	0.80	
				4183	836.6		0.42	0.73	0.81	
				4233	846.6		0.41	0.78	0.86	

## B.5.2 LTE

### UL CA 5BC

UL CA shall be tested based on the worst-case SAR configuration determined from non-CA SAR testing result. The channel BW, channel number, RB allocation, etc. would be selected to allow contiguous CA of PCC and SCC. Uplink output power for UL CA is the total power measured across the PCC and SCC. From the above table on standalone testing on LTE Band7, Laptop position with low channel is chosen as the configuration that gives the highest SAR, thus, the same is used for UL CA testing

Band	Antenna	Modulation / BW	PCC			SCC			Position	Scaling Factor (dB)	Measured SAR 1g (W/Kg)	Reported SAR 1g (W/Kg)
			Ch	Freq (MHz)	RB Allocation	Ch	Freq (MHz)	RB Allocation				
LTE 5B	HongBo	QPSK / 20MHz	26775	822.5	1RB High	20476	831.6	1RB Low	Laptop	0.33	0.75	0.81
	WNC	QPSK / 20MHz	26775	822.5	1RB High	20476	831.6	1RB Low	Laptop	0.33	0.63	0.68

PCC RB allocation settings for UL CA have been adjusted based on the worst-case power

#### B.5.2.1 LTE Band 7 FDD

Band	Antenna	BW (MHz)	Mod.	Channel Number	Freq (MHz)	Position	% RB Allocation	Scaling Factor (dB)	Measured SAR 1g (W/kg)	Reported SAR 1g (W/kg)	Plot #
Band 7	HongBo	20	QPSK	21100	2535	Laptop	1RB Mid	0.60	0.55	0.63	
							50RB Mid	0.67	0.55	0.64	4
	WNC	20	QPSK	21100	2535	Laptop	1RB Mid	0.60	0.43	0.49	
							50RB Mid	0.67	0.43	0.50	

#### B.5.2.2 LTE Band 12 FDD

Band	Antenna	BW (MHz)	Mod.	Channel Number	Freq (MHz)	Position	% RB Allocation	Scaling Factor (dB)	Measured SAR 1g (W/kg)	Reported SAR 1g (W/kg)	Plot #
Band 12	HongBo	10	QPSK	22095	707.5	Laptop	1RB Mid	1.32	0.71	0.96	
							50RB Mid	1.38	0.70	0.96	
							100RB Mid	1.45	0.68	0.95	
	WNC	10	QPSK	23095	707.5	Laptop	1RB Mid	1.32	0.80	1.09	
							50RB Mid	1.38	0.79	1.09	
							100RB Mid	1.45	0.79	1.10	5

#### B.5.2.3 LTE Band 13 FDD

Band	Antenna	BW (MHz)	Mod.	Channel Number	Freq (MHz)	Position	% RB Allocation	Scaling Factor (dB)	Measured SAR 1g (W/kg)	Reported SAR 1g (W/kg)	Plot #
Band 13	HongBo	10	QPSK	23230	782	Laptop	1RB Mid	0.65	0.80	0.93	6
							50RB Mid	0.70	0.79	0.93	
							100RB Mid	0.67	0.77	0.90	
	WNC	10	QPSK	23230	782	Laptop	1RB Mid	0.65	0.77	0.89	
							50RB Mid	0.70	0.76	0.89	
							100RB Mid	0.67	0.76	0.89	

**B.5.2.4 LTE Band 14 FDD**

Band	Antenna	BW (MHz)	Mod.	Channel Number	Freq (MHz)	Position	% RB Allocation	Scaling Factor (dB)	Measured SAR 1g (W/kg)	Reported SAR 1g (W/kg)	Plot #
Band 14	HongBo	10	QPSK	23330	793	Laptop	1RB Mid	0.92	0.72	0.89	7
							50RB Mid	1.00	0.69	0.87	
							100RB Mid	0.90	0.69	0.85	
	WNC	10	QPSK	23330	793	Laptop	1RB Mid	0.92	0.68	0.84	
							50RB Mid	1.00	0.67	0.84	
							100RB Mid	0.90	0.67	0.82	

**B.5.2.5 LTE Band 25 FDD**

Band	Antenna	BW (MHz)	Mod.	Channel Number	Freq (MHz)	Position	% RB Allocation	Scaling Factor (dB)	Measured SAR 1g (W/kg)	Reported SAR 1g (W/kg)	Plot #
Band 25	HongBo	20	QPSK	26365	1882.5	Laptop	1RB Mid	0.93	0.58	0.72	
							50RB Mid	0.86	0.61	0.74	8
	WNC	20	QPSK	26365	1882.5	Laptop	1RB Mid	0.93	0.55	0.68	
							50RB Mid	0.86	0.56	0.68	

**B.5.2.6 LTE Band 26 FDD**

Band	Antenna	BW (MHz)	Mod.	Channel Number	Freq (MHz)	Position	% RB Allocation	Scaling Factor (dB)	Measured SAR 1g (W/kg)	Reported SAR 1g (W/kg)	Plot #
Band 26	HongBo	15	QPSK	26765	821.5	Laptop	1RB Mid	0.55	0.83	0.94	
							50RB Mid	0.62	0.82	0.94	
				26865	831.5		1RB Mid	0.62	0.82	0.95	
							50RB Mid	0.54	0.83	0.94	
				26965	841.5		100RB Mid	0.76	0.84	1.00	
							1RB Mid	0.60	0.87	1.00	9
							50RB Mid	0.62	0.86	0.99	
	WNC	15	QPSK	26765	821.5	Laptop	1RB Mid	0.55	0.72	0.82	
							50RB Mid	0.86	0.57	0.70	
				26865	831.5		1RB Mid	0.62	0.68	0.78	
							50RB Mid	0.80	0.68	0.82	
				26965	841.5		100RB Mid	0.76	0.60	0.71	
							1RB Mid	0.60	0.76	0.87	
							50RB Mid	0.99	0.61	0.77	

**B.5.2.7 LTE Band 30 FDD**

Band	Antenna	BW (MHz)	Mod.	Channel Number	Freq (MHz)	Position	% RB Allocation	Scaling Factor (dB)	Measured SAR 1g (W/kg)	Reported SAR 1g (W/kg)	Plot #
Band 30	HongBo	10	QPSK	27710	2310	Laptop	1RB Mid	0.94	0.69	0.86	
							50RB Mid	0.97	0.69	0.87	10
							100RB Mid	0.87	0.70	0.85	
	WNC	10	QPSK	27710	2310	Laptop	1RB Mid	0.94	0.56	0.69	
							50RB Mid	0.97	0.56	0.69	

**B.5.2.8 LTE Band 41 TDD**

Band	Antenna	BW (MHz)	Mod.	Channel Number	Freq (MHz)	Position	% RB Allocation	Scaling Factor (dB)	Measured SAR 1g (W/kg)	Reported SAR 1g (W/kg)	Plot #
Band 41	HongBo	20	QPSK	40620	2593	Laptop	1RB Mid	0.74	0.35	0.42	
							50RB Mid	0.76	0.35	0.42	11
	WNC	20	QPSK	40620	2593	Laptop	1RB Mid	0.74	0.24	0.28	
							50RB Mid	0.76	0.24	0.28	

**UL CA 41C**

UL CA shall be tested based on the worst-case SAR configuration determined from non-CA SAR testing result. The channel BW, channel number, RB allocation, etc. would be selected to allow contiguous CA of PCC and SCC. Uplink output power for UL CA is the total power measured across the PCC and SCC.

From the above table on standalone testing on LTE Band41, Back Face position on antenna5 and Laptop on antenna8 are chosen as the configurations that give the highest SAR, thus, the same is used for UL CA testing.

Band	Antenna	Modulation / BW	PCC			SCC			Position	Scaling Factor (dB)	Measured SAR 1g (W/Kg)	Reported SAR 1g (W/Kg)
			Ch	Freq (MHz)	RB Allocation	Ch	Freq (MHz)	RB Allocation				
LTE 41C	HongBo	QPSK / 20MHz	40521	2583.1	1RB High	40719	2602.9	1RB Low	Laptop	0.23	0.12	0.12
	WNC	QPSK / 20MHz	40521	2583.1	1RB High	40719	2602.9	1RB Low	Laptop	0.23	0.15	0.15

PCC RB allocation settings for UL CA have been adjusted based on the worst-case power

**B.5.2.9 LTE Band 48 TDD**

Band	Antenna	BW (MHz)	Mod.	Channel Number	Freq (MHz)	Position	% RB Allocation	Scaling Factor (dB)	Measured SAR 1g (W/kg)	Reported SAR 1g (W/kg)	Plot #
Band 48	HongBo	20	QPSK	55990	3625	Laptop	1RB Mid	0.90	0.44	0.55	12
							50RB Mid	1.33	0.33	0.45	
	WNC	20	QPSK	55990	3625	Laptop	1RB Mid	0.90	0.42	0.51	
							50RB Mid	1.33	0.40	0.55	

**B.5.2.10 LTE Band 66 FDD**

Band	Antenna	BW (MHz)	Mod.	Channel Number	Freq (MHz)	Position	% RB Allocation	Scaling Factor (dB)	Measured SAR 1g (W/kg)	Reported SAR 1g (W/kg)	Plot #
Band 66	HongBo	20	QPSK	132322	1745	Laptop	1RB Mid	0.65	0.68	0.79	
							50RB Mid	0.68	0.68	0.79	
	WNC	20	QPSK	132072	1720	Laptop	1RB Mid	0.51	0.79	0.89	
							50RB Mid	0.53	0.80	0.90	
				132322	1745		1RB Mid	0.65	0.88	1.02	
							50RB Mid	0.68	0.88	1.03	
				132572	1770		100RB Mid	0.68	0.91	1.07	
							1RB Mid	0.89	0.94	1.15	
				50RB Mid	0.85		0.97	1.18	13		

**UL CA 66B, 66C**

UL CA shall be tested based on the worst-case SAR configuration determined from non-CA SAR testing result. The channel BW, channel number, RB allocation, etc. would be selected to allow contiguous CA of PCC and SCC. Uplink output power for UL CA is the total power measured across the PCC and SCC.

From the above table on standalone testing on LTE Band66, Laptop position in the low channel is chosen as the configurations that gives the highest SAR, thus, the same is used for UL CA testing for the 66C mode. Since the 10MHz was not tested in standalone, due to KDB 941225 reduction list, the initial configuration for the 66B mode was taken from the worst-case scenario of the 20MHz

Band	Antenna	Modulation / BW	PCC			SCC			Position	Scaling Factor (dB)	Measured SAR 1g (W/Kg)	Reported SAR 1g (W/Kg)
			Ch	Freq (MHz)	RB Allocation	Ch	Freq (MHz)	RB Allocation				
LTE 66B	HongBo	QPSK / 20MHz	132373	1750.1	1RB High	132472	1760	1RB Low	Laptop	0.60	0.50	0.57
	WNC	QPSK / 20MHz	132373	1750.1	1RB High	132472	1760	1RB Low	Laptop	0.60	0.49	0.57
LTE 66C	HongBo	QPSK / 20MHz	132323	2145.1	1RB High	132521	1764.9	1RB Low	Laptop	0.40	0.51	0.56
	WNC	QPSK / 20MHz	132323	2145.1	1RB High	132521	1764.9	1RB Low	Laptop	0.40	0.39	0.42

PCC RB allocation settings for UL CA have been adjusted based on the worst-case power

### B.5.3 SAR Measurement Variability

According to FCC OET KDB 865664, SAR Measurement variability is assessed when the maximum initial measured SAR is  $\geq 0.8$  W/kg for a certain band/mode. If the measured SAR value of the initial repeated measurement is  $< 1.45$  W/kg with  $< 20\%$  variation, only one repeated measurement is required to confirm that the results are not expected to have substantial variations.

A second repeated measurement is required only if the measured results for the initial repeated measurement are within 10% of the SAR limit or vary by more than 20%.

A third repeated measurement is required only if the original, first or second repeated measurement  $\geq 1.5$ W/Kg and the ratio of largest to smallest SAR for the original, first and second repeated measurement is  $> 1.2$ .

Band / Mode	Position	Ch #	Freq. (MHz)	Measured SAR 1g (W/kg)	1 <sup>st</sup> Repeated SAR 1g (W/kg)	2 <sup>nd</sup> Repeated SAR 1g (W/kg)	Highest Ratio
LTE FDD 13 / QPSK – 10MHz	Laptop	23230	782	0.80	0.80		1.00
WCDMA V / QPSK – 5MHz	Laptop	4183	836.6	0.87	0.87		1.00
LTE FDD 66 / QPSK – 20MHz	Laptop	132572	1770	0.97	0.97		1.00

### B.5.4 Simultaneous Transmission SAR Evaluation

According to FCC OET KDB 447498 D01, when the sum of 1g SAR for all simultaneously transmitting antennas in an operating mode and exposure condition combination is within the SAR limit, SAR test exclusion applies to that simultaneous transmission configuration.

All the values stated in the table below are the worst case found for standalone measurement with disregard of the transmission mode or channel where the worst case was found.

Antenna	Position	Highest Reported SAR (1g) (W/kg)			
		WWAN	WLAN 2.4GHz	WLAN 5/6GHz	Bluetooth
WWAN Ant5 (Tx/RX)	Laptop	1.18			
Main WLAN	Laptop		0.40*	0.40*	
Aux WLAN	Laptop		0.40*	0.40*	0.40*

\*According to FCC OET KDB 447498 D01, when standalone test exclusion is applied to an antenna that transmits simultaneously with other antennas, the standalone SAR must be estimated to 0.4 W/Kg for 1-g SAR when the test separation is > 50mm in order to determine simultaneous transmission test exclusion.

Position	Simultaneous Tx Antenna Combination				Σ SAR 1g (W/Kg)	Limit (W/kg)
	#	WWAN Main Ant5	Main Antenna	Aux Antenna		
Laptop	1	Cellular	WLAN 5/6GHz	WLAN 5/6GHz	<b>1.98</b>	1.6
	2	Cellular	WLAN 5/6GHz	WLAN 5/6GHz+ BT	<b>2.38</b>	
	3	Cellular	WLAN 5/6GHz	BT	<b>1.98</b>	
	4	Cellular	WLAN 2.4GHz	WLAN 2.4GHz	<b>1.98</b>	
	5	Cellular	WLAN 2.4GHz	BT	<b>1.98</b>	

In case the sum of SAR is larger than the limit, SAR test exclusion is determined by the SAR to peak location separation ratio (SPLSR). According to the last table possible simultaneous transmission combinations are identified for each position from 1 to 5, each combination will be analyzed by antenna pairs. Antenna pairs considered in one configuration won't be performed again in case they are repeated on the next simultaneous configuration:



Position	Ant. Pair case	Antenna	Reported SAR 1g (W/kg)	$\Sigma$ SAR 1g (W/Kg)	Peak Location (mm) (x,y,z)	SAR to peak location separation ratio	Limit
Laptop	1a	WWAN Ant5 (TX/RX)	1.18	1.58			0.04
		Main WLAN 5/6GHz	0.40				
	1b	WWAN Ant5 (TX/RX)	1.18	1.58			
		Aux WLAN 5/6GHz	0.40				
	1c	Main WLAN 5/6GHz	0.40	0.80			
		Aux WLAN 5/6GHz	0.40				
	2a	WWAN Ant5 (TX/RX)	1.18	1.58			
		Aux WLAN1 BT	0.40				
	4a	WWAN Ant5 (TX/RX)	1.18	1.58			
		Main WLAN 2.4GHz	0.40				
	4b	WWAN Ant5 (TX/RX)	1.18	1.58			
		Aux WLAN 2.4GHz	0.40				
	4c	Main WLAN 2.4GHz	0.40	0.80			
		Aux WLAN 2.4GHz	0.40				

Considering the results described above and according to the simultaneous transmission evaluation exclusions described in FCC OET KDB 447498 D01, no SPLSR nor enlarged zoom scan measurements are required.

# Annex C. Test System Plots

---

1.	WCDMA Band II, QPSK - 5MHz, CH9400, Antenna HongBo .....	59
2.	WCDMA Band IV, QPSK - 5MHz, CH1413, Antenna HongBo .....	60
3.	WCDMA Band V, QPSK - 5MHz, CH4183, Antenna HongBo.....	61
4.	LTE Band 7, QPSK - 20MHz, CH21100, Antenna HongBo .....	62
5.	LTE Band 12, QPSK - 10MHz, CH23095, Antenna WNC.....	63
6.	LTE Band 13, QPSK - 10MHz, CH23230, Antenna HongBo .....	64
7.	LTE Band 14, QPSK - 10MHz, CH23330, Antenna HongBo .....	65
8.	LTE Band 25, QPSK - 20MHz, CH26365, Antenna HongBo .....	66
9.	LTE Band 26, QPSK - 15MHz, CH26965, Antenna HongBo .....	67
10.	LTE Band 30, QPSK - 10MHz, CH27710, Antenna HongBo.....	68
11.	LTE Band 41, QPSK - 20MHz, CH41490, Antenna HongBo.....	69
12.	LTE Band 48, QPSK - 20MHz, CH55990, Antenna HongBo.....	70
13.	LTE Band 66, QPSK - 20MHz, CH132572, Antenna WNC .....	71
14.	System Check Body Liquid 750MHz – 2022-01-07 .....	72
15.	System Check Body Liquid 750MHz – 2022-01-27 .....	73
16.	System Check Body Liquid 835MHz – 2022-01-28.....	74
17.	System Check Body Liquid 1750MHz – 2022-01-07.....	75
18.	System Check Body Liquid 1750MHz – 2022-01-28.....	76
19.	System Check Body Liquid 1900MHz .....	77
20.	System Check Body Liquid 2300MHz .....	78
21.	System Check Body Liquid 2600MHz .....	79
22.	System Check Body Liquid 3700MHz .....	80

## 1. WCDMA Band II, QPSK - 5MHz, CH9400, Antenna HongBo

### Device under Test Properties

Name, Manufacturer	Dimensions [mm]	S/N	DUT Type
HSN-I50C	295.0 x 220.0 x 17.0	0001760GOC	Laptop

### Exposure Conditions

Phantom Section, TSL	Position, Test Distance [mm]	Band	Group, UID	Frequency [MHz], Channel Number	Conversion Factor	TSL Conductivity [S/m]	TSL Permittivity
Flat, MSL	Laptop, 0.00	Band 2, UTRA/FDD	WCDMA, 10011-CAB	1880.0, 9400	7.98	1.47	50.5

### Hardware Setup

Phantom	TSL, Measured Date	Probe, Calibration Date	DAE, Calibration Date
ELI V8.0 (20deg probe tilt)	MBBL-600-6000, 2022-Jan-27	EX3DV4 - SN3978, 2021-05-21	DAE4 Sn1429, 2021-05-11

### Scan Setup

	Area Scan	Zoom Scan
Grid Extents [mm]	120.0 x 120.0	30.0 x 30.0 x 30.0
Grid Steps [mm]	15.0 x 15.0	6.0 x 6.0 x 1.5
Sensor Surface [mm]	3.0	1.4
Graded Grid	Yes	Yes
Grading Ratio	n/a	1.5
MAIA	Confirmed by MAIA	Confirmed by MAIA
Surface Detection	VMS + 6p	VMS + 6p
Scan Method	Measured	Measured

### Measurement Results

	Area Scan	Zoom Scan
Date	2022-01-28, 10:37	2022-01-28, 10:43
psSAR1g [W/kg]	0.530	0.617
psSAR10g [W/kg]	0.280	0.308
Power Drift [dB]	-0.01	0.05
Power Scaling	Disabled	Disabled
Scaling Factor [dB]		
TSL Correction	Positive Only	Positive Only
M2/M1 [%]		81.6
Dist 3dB Peak [mm]		8.5

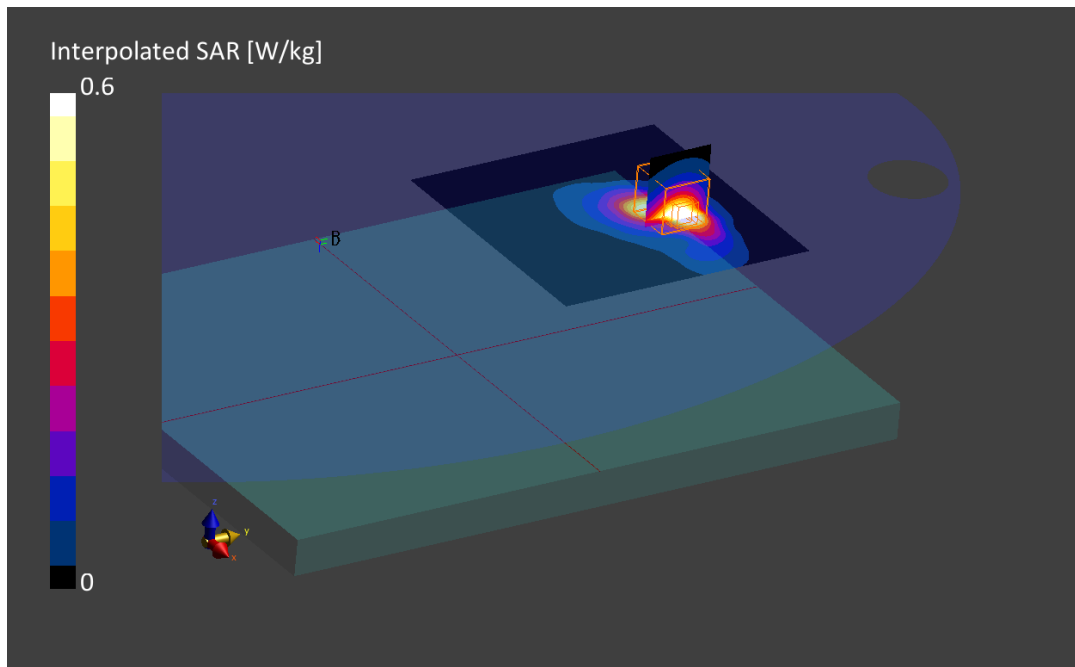

## 2. WCDMA Band IV, QPSK - 5MHz, CH1413, Antenna HongBo

### Device under Test Properties

Name, Manufacturer	Dimensions [mm]	S/N	DUT Type
HSN-I50C	295.0 x 220.0 x 17.0	0001760GOC	Laptop

### Exposure Conditions

Phantom Section, TSL	Position, Test Distance [mm]	Band	Group, UID	Frequency [MHz], Channel Number	Conversion Factor	TSL Conductivity [S/m]	TSL Permittivity
Flat, MSL	Laptop, 0.00	Band4, UTRA/FDD	WCDMA, 10011-CAB	1732.6, 1413	8.37	1.40	50.5

### Hardware Setup

Phantom	TSL, Measured Date	Probe, Calibration Date	DAE, Calibration Date
ELI V8.0 (20deg probe tilt)	MABL-600-6000, 2022-Jan-27	EX3DV4 - SN3978, 2021-05-21	DAE4 Sn1429, 2021-05-11

### Scan Setup

	Area Scan	Zoom Scan
Grid Extents [mm]	120.0 x 120.0	30.0 x 30.0 x 30.0
Grid Steps [mm]	15.0 x 15.0	6.0 x 6.0 x 1.5
Sensor Surface [mm]	3.0	1.4
Graded Grid	Yes	Yes
Grading Ratio	1.5	1.5
MAIA	Confirmed by MAIA	Confirmed by MAIA
Surface Detection	VMS + 6p	VMS + 6p
Scan Method	Measured	Measured

### Measurement Results

	Area Scan	Zoom Scan
Date	2022-01-28, 10:56	2022-01-28, 11:02
psSAR1g [W/kg]	0.598	0.688
psSAR10g [W/kg]	0.329	0.354
Power Drift [dB]	0.00	0.05
Power Scaling	Disabled	Disabled
Scaling Factor [dB]		
TSL Correction	Positive Only	Positive Only
M2/M1 [%]		80.8
Dist 3dB Peak [mm]		9.4

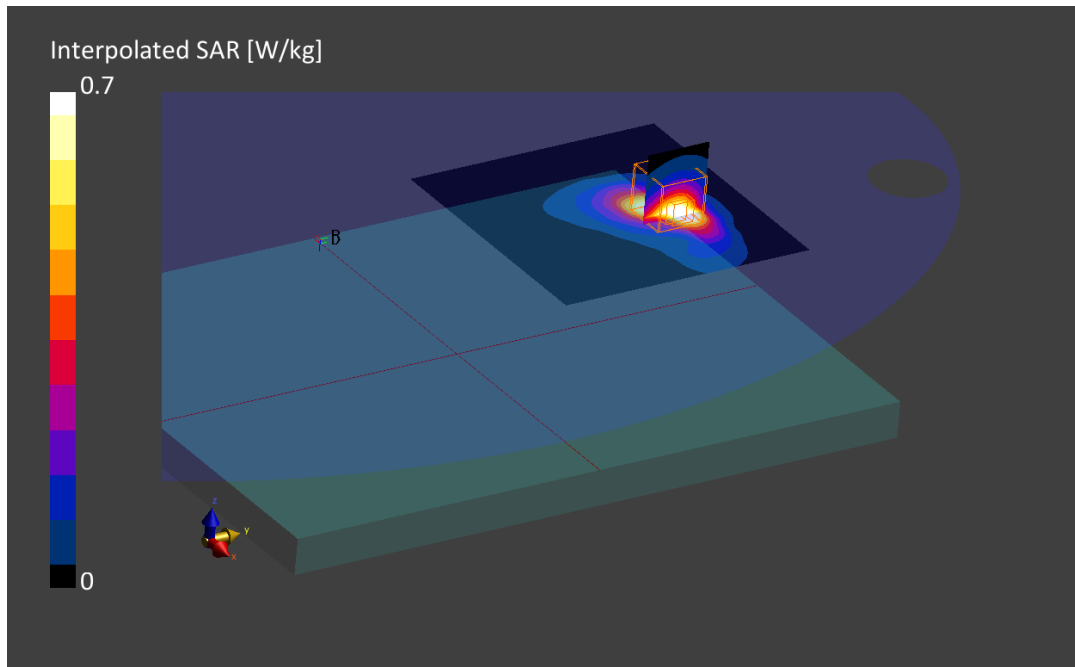

### 3. WCDMA Band V, QPSK - 5MHz, CH4183, Antenna HongBo

**Device under Test Properties**

Name, Manufacturer	Dimensions [mm]	S/N	DUT Type
HSN-I50C	295.0 x 220.0 x 17.0	0001760GOC	Laptop

**Exposure Conditions**

Phantom Section, TSL	Position, Test Distance [mm]	Band	Group, UID	Frequency [MHz], Channel Number	Conversion Factor	TSL Conductivity [S/m]	TSL Permittivity
Flat, MSL	Laptop, 0.00	Band5, UTRA/FDD	WCDMA, 10011-CAB	836.6, 4183	9.32	0.920	52.0

**Hardware Setup**

Phantom	TSL, Measured Date	Probe, Calibration Date	DAE, Calibration Date
ELI V8.0 (20deg probe tilt)	MABL-600-6000, 2022-Jan-27	EX3DV4 - SN3978, 2021-05-21	DAE4 Sn1429, 2021-05-11

**Scan Setup**

	Area Scan	Zoom Scan
Grid Extents [mm]	120.0 x 120.0	30.0 x 30.0 x 30.0
Grid Steps [mm]	15.0 x 15.0	6.0 x 6.0 x 1.5
Sensor Surface [mm]	3.0	1.4
Graded Grid	Yes	Yes
Grading Ratio	1.5	1.5
MAIA	Confirmed by MAIA	Confirmed by MAIA
Surface Detection	VMS + 6p	VMS + 6p
Scan Method	Measured	Measured

**Measurement Results**

	Area Scan	Zoom Scan
Date	2022-01-28, 12:28	2022-01-28, 12:34
psSAR1g [W/kg]	0.823	0.846
psSAR10g [W/kg]	0.525	0.506
Power Drift [dB]	-0.01	0.01
Power Scaling	Disabled	Disabled
Scaling Factor [dB]		
TSL Correction	Positive Only	Positive Only
M2/M1 [%]		82.6
Dist 3dB Peak [mm]		11.8

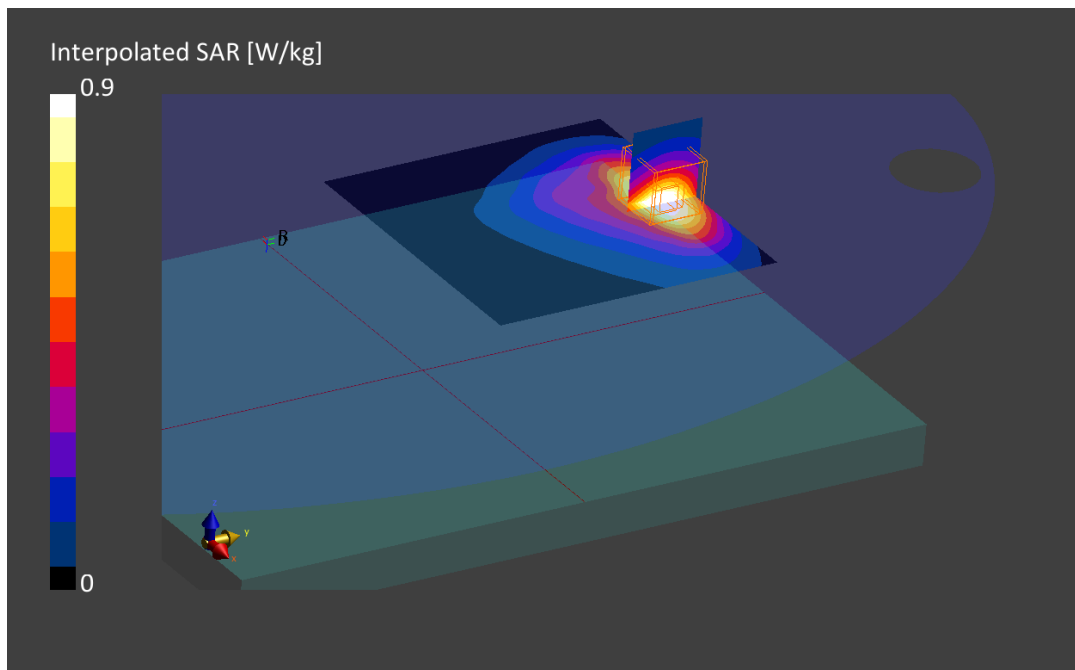

### 4. LTE Band 7, QPSK - 20MHz, CH21100, Antenna HongBo

**Device under Test Properties**

Name, Manufacturer	Dimensions [mm]	S/N	DUT Type
HSN-I50C	295.0 x 220.0 x 17.0	0001760GOC	Laptop

**Exposure Conditions**

Phantom Section, TSL	Position, Test Distance [mm]	Band	Group, UID	Frequency [MHz], Channel Number	Conversion Factor	TSL Conductivity [S/m]	TSL Permittivity
Flat, MS�	Laptop, 0.00	Band 7, E-UTRA/FDD	LTE-FDD, 10297-AAD	2535.0, 21100	7.24	2.03	49.6

**Hardware Setup**

Phantom	TSL, Measured Date	Probe, Calibration Date	DAE, Calibration Date
ELI V8.0 (20deg probe tilt)	MBBL-600-6000, 2022-Jan-27	EX3DV4 - SN3978, 2021-05-21	DAE4 Sn1429, 2021-05-11

**Scan Setup**

	Area Scan	Zoom Scan
Grid Extents [mm]	100.0 x 100.0	30.0 x 30.0 x 30.0
Grid Steps [mm]	10.0 x 10.0	5.0 x 5.0 x 1.5
Sensor Surface [mm]	3.0	1.4
Graded Grid	Yes	Yes
Grading Ratio	1.5	1.5
MAIA	Confirmed by MAIA	Confirmed by MAIA
Surface Detection	VMS + 6p	VMS + 6p
Scan Method	Measured	Measured

**Measurement Results**

	Area Scan	Zoom Scan
Date	2022-01-27, 23:17	2022-01-27, 23:24
psSAR1g [W/kg]	0.533	0.548
psSAR10g [W/kg]	0.272	0.279
Power Drift [dB]	-0.01	0.11
Power Scaling	Disabled	Disabled
Scaling Factor [dB]		
TSL Correction	Positive Only	Positive Only
M2/M1 [%]		81.1
Dist 3dB Peak [mm]		9.8

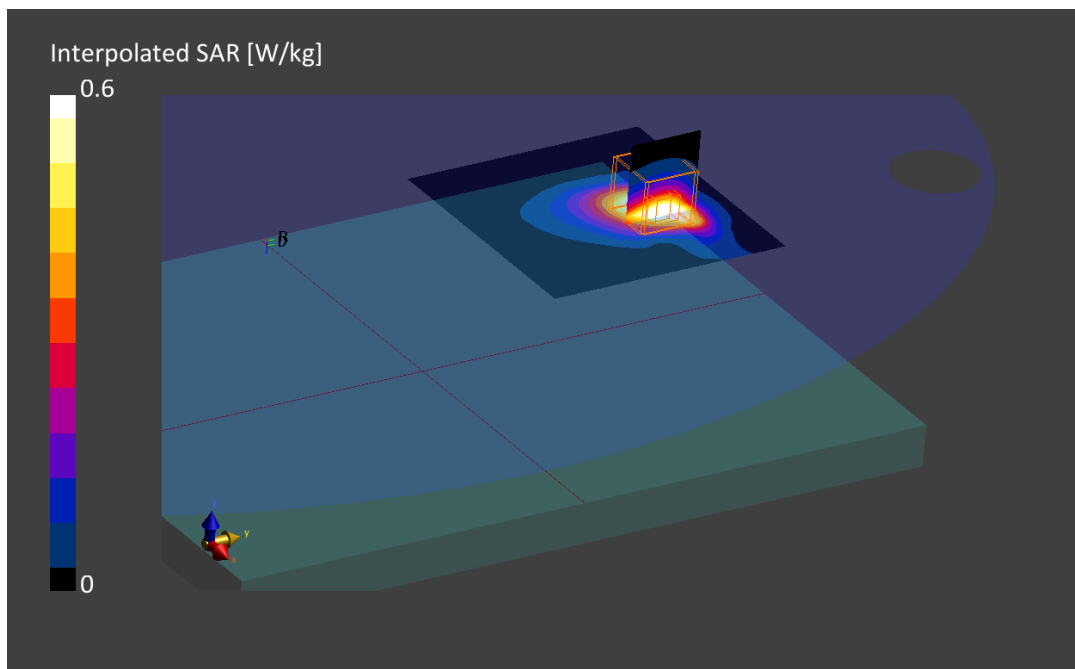

## 5. LTE Band 12, QPSK - 10MHz, CH23095, Antenna WNC

### Device under Test Properties

Model, Manufacturer	Dimensions [mm]	S/N	DUT Type
HSN-I50C	295.0 x 220.0 x 17.0	0001760GWR	Laptop

### Exposure Conditions

Phantom Section, TSL	Position, Test Distance [mm]	Band	Group, UID	Frequency [MHz], Channel Number	Conversion Factor	TSL Conductivity [S/m]	TSL Permittivity
Flat, MSL	Laptop, 0.00	Band 12, E-UTRA/FDD	LTE-FDD, 10108-CAG	707.5, 23095	9.63	0.91	54.1

### Hardware Setup

Phantom	TSL, Measured Date	Probe, Calibration Date	DAE, Calibration Date
ELI V8.0 (20deg probe tilt)	MABL-600-6000, 2022-Jan-06	EX3DV4 - SN3978, 2021-05-21	DAE4 Sn1429, 2021-05-11

### Scan Setup

	Area Scan	Zoom Scan
Grid Extents [mm]	120.0 x 120.0	30.0 x 30.0 x 30.0
Grid Steps [mm]	15.0 x 15.0	6.0 x 6.0 x 1.5
Sensor Surface [mm]	3.0	1.4
Graded Grid	Yes	Yes
Grading Ratio	1.5	1.5
MAIA	Confirmed by MAIA	Confirmed by MAIA
Surface Detection	VMS + 6p	VMS + 6p
Scan Method	Measured	Measured

### Measurement Results

	Area Scan	Zoom Scan
Date	2022-01-08, 00:04	2022-01-08, 00:10
psSAR1g [W/kg]	0.731	0.787
psSAR10g [W/kg]	0.465	0.461
Power Drift [dB]	-0.03	0.03
Power Scaling	Disabled	Disabled
Scaling Factor		
TSL Correction	Positive Only	Positive Only
M2/M1 [%]		83.4
Dist 3dB Peak [mm]		10.3

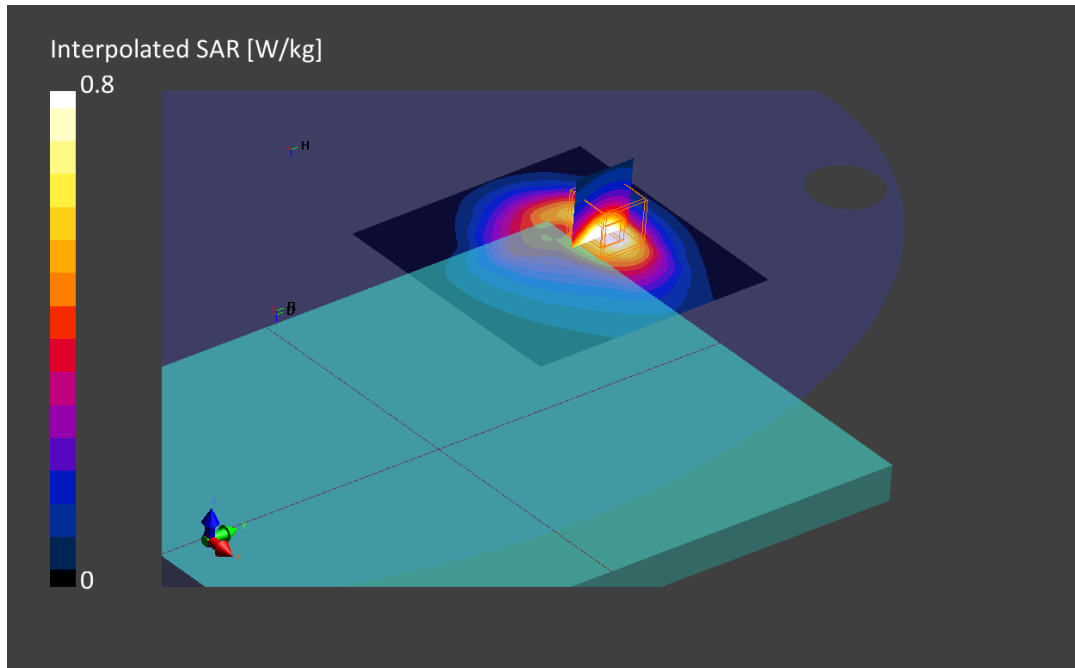

## 6. LTE Band 13, QPSK - 10MHz, CH23230, Antenna HongBo

### Device under Test Properties

Model, Manufacturer	Dimensions [mm]	S/N	DUT Type
HSN-I50C	295.0 x 220.0 x 17.0	0001760GOC	Laptop

### Exposure Conditions

Phantom Section, TSL	Position, Test Distance [mm]	Band	Group, UID	Frequency [MHz], Channel Number	Conversion Factor	TSL Conductivity [S/m]	TSL Permittivity
Flat, MSL	Laptop, 0.00	Band 13, E-UTRA/FDD	LTE-FDD, 10175-CAG	782.0, 23230	9.63	0.901	52.2

### Hardware Setup

Phantom	TSL, Measured Date	Probe, Calibration Date	DAE, Calibration Date
ELI V8.0 (20deg probe tilt)	MBBL-600-6000, 2022-Jan-27	EX3DV4 - SN3978, 2021-05-21	DAE4 Sn1429, 2021-05-11

### Scan Setup

	Area Scan	Zoom Scan
Grid Extents [mm]	120.0 x 120.0	30.0 x 30.0 x 30.0
Grid Steps [mm]	15.0 x 15.0	6.0 x 6.0 x 1.5
Sensor Surface [mm]	3.0	1.4
Graded Grid	Yes	Yes
Grading Ratio	1.5	1.5
MAIA	Confirmed by MAIA	Confirmed by MAIA
Surface Detection	VMS + 6p	VMS + 6p
Scan Method	Measured	Measured

### Measurement Results

	Area Scan	Zoom Scan
Date	2022-01-27, 21:25	2022-01-27, 21:32
psSAR1g [W/kg]	0.793	0.799
psSAR10g [W/kg]	0.506	0.495
Power Drift [dB]	-0.01	0.00
Power Scaling	Disabled	Disabled
Scaling Factor		
TSL Correction	Positive Only	Positive Only
M2/M1 [%]		83.3
Dist 3dB Peak [mm]		11.8

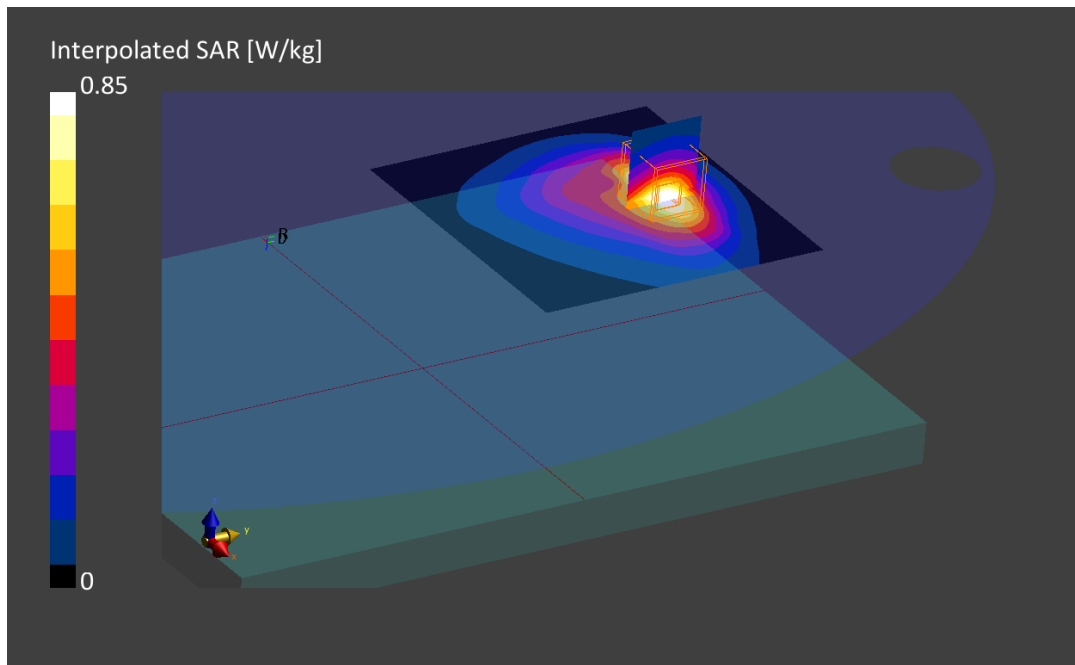



## 7. LTE Band 14, QPSK - 10MHz, CH23330, Antenna HongBo

### Device under Test Properties

Name, Manufacturer	Dimensions [mm]	S/N	DUT Type
HSN-I50C	295.0 x 220.0 x 17.0	0001760GOC	Laptop

### Exposure Conditions

Phantom Section, TSL	Position, Test Distance [mm]	Band	Group, UID	Frequency [MHz], Channel Number	Conversion Factor	TSL Conductivity [S/m]	TSL Permittivity
Flat, MSL	Laptop, 0.00	Band 14, E-UTRA/FDD	LTE-FDD, 10175-CAG	793.0, 23330	9.63	0.905	52.1

### Hardware Setup

Phantom	TSL, Measured Date	Probe, Calibration Date	DAE, Calibration Date
ELI V8.0 (20deg probe tilt)	MABL-600-6000, 2022-Jan-27	EX3DV4 - SN3978, 2021-05-21	DAE4 Sn1429, 2021-05-11

### Scan Setup

	Area Scan	Zoom Scan
Grid Extents [mm]	120.0 x 120.0	30.0 x 30.0 x 30.0
Grid Steps [mm]	15.0 x 15.0	6.0 x 6.0 x 1.5
Sensor Surface [mm]	3.0	1.4
Graded Grid	Yes	Yes
Grading Ratio	1.5	1.5
MAIA	Confirmed by MAIA	Confirmed by MAIA
Surface Detection	VMS + 6p	VMS + 6p
Scan Method	Measured	Measured

### Measurement Results

	Area Scan	Zoom Scan
Date	2022-01-27, 22:14	2022-01-27, 22:21
psSAR1g [W/kg]	0.729	0.723
psSAR10g [W/kg]	0.460	0.449
Power Drift [dB]	-0.01	0.02
Power Scaling	Disabled	Disabled
Scaling Factor [dB]		
TSL Correction	Positive Only	Positive Only
M2/M1 [%]		82.1
Dist 3dB Peak [mm]		11.8

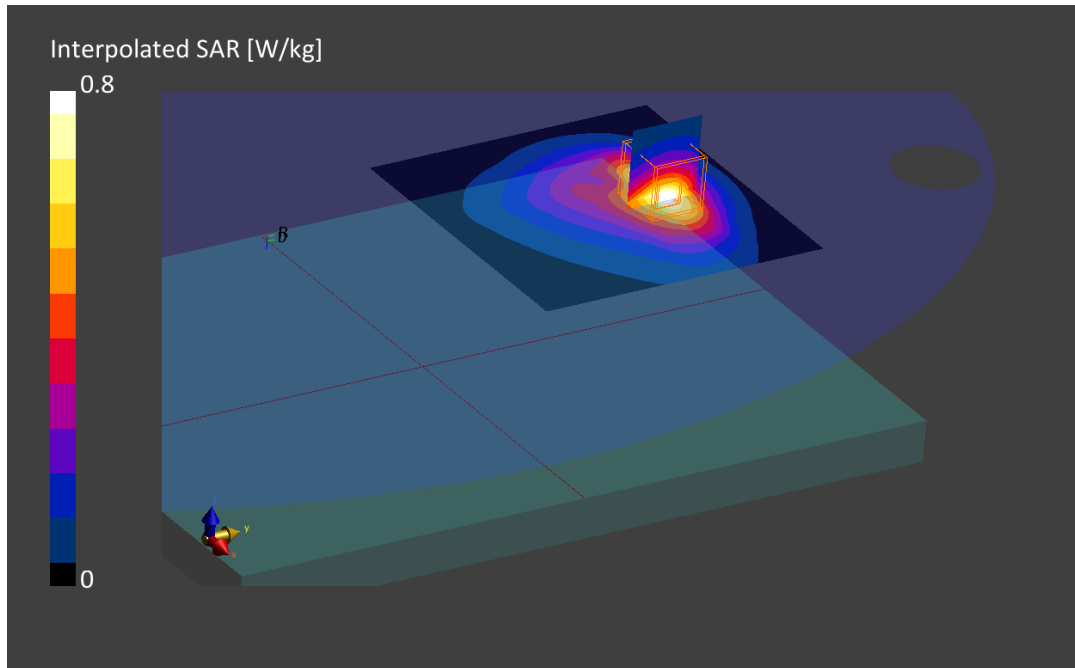

## 8. LTE Band 25, QPSK - 20MHz, CH26365, Antenna HongBo

### Device under Test Properties

Name, Manufacturer	Dimensions [mm]	S/N	DUT Type
HSN-I50C	295.0 x 220.0 x 17.0	0001760GOC	Laptop

### Exposure Conditions

Phantom Section, TSL	Position, Test Distance [mm]	Band	Group, UID	Frequency [MHz], Channel Number	Conversion Factor	TSL Conductivity [S/m]	TSL Permittivity
Flat MSL	Laptop 0.00	Band 25, E-UTRA/FDD	LTE-FDD, 10297-AAD	1882.5, 26365	7.98	1.48	50.5

### Hardware Setup

Phantom	TSL, Measured Date	Probe, Calibration Date	DAE, Calibration Date
ELI V8.0 (20deg probe tilt) - 2124	MBBL-600-6000, 2022-Jan-27	EX3DV4 - SN3978, 2021-05-21	DAE4 Sn1429, 2021-05-11

### Scan Setup

	Area Scan	Zoom Scan
Grid Extents [mm]	120.0 x 120.0	30.0 x 30.0 x 30.0
Grid Steps [mm]	15.0 x 15.0	6.0 x 6.0 x 1.5
Sensor Surface [mm]	3.0	1.4
Graded Grid	Yes	Yes
Grading Ratio	1.5	1.5
MAIA	Confirmed by MAIA	Confirmed by MAIA
Surface Detection	Yes	Yes
Scan Method	Measured	Measured

### Measurement Results

	Area Scan	Zoom Scan
Date	2022-01-28, 00:55	2022-01-28, 01:01
SAR1g [W/Kg]	0.533	0.612
SAR10g [W/Kg]	0.286	0.312
Power Drift [dB]	-0.07	0.06
Power Scaling	Disabled	Disabled
Scaling Factor [dB]		
TSL Correction	Positive Only	Positive Only

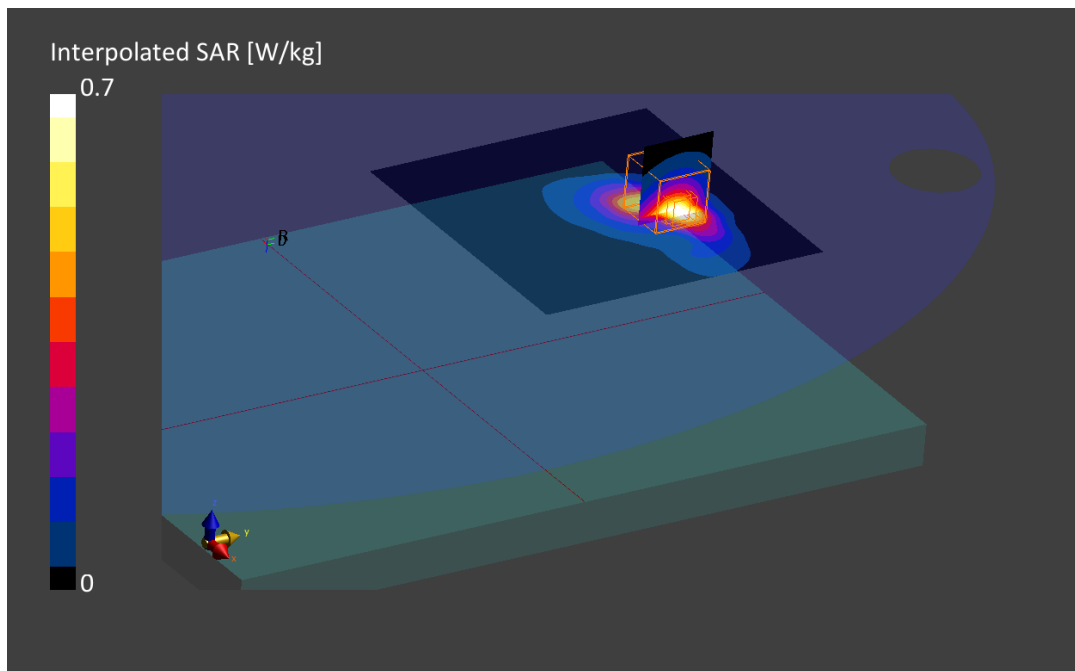

## 9. LTE Band 26, QPSK - 15MHz, CH26965, Antenna HongBo

### Device under Test Properties

Name, Manufacturer	Dimensions [mm]	S/N	DUT Type
HSN-I50C	295.0 x 220.0 x 17.0	0001760GOC	Laptop

### Exposure Conditions

Phantom Section, TSL	Position, Test Distance [mm]	Band	Group, UID	Frequency [MHz], Channel Number	Conversion Factor	TSL Conductivity [S/m]	TSL Permittivity
Flat MSL	Laptop 0.00	Band 26 E-UTRA/FDD	LTE-FDD, 10160-CAE	841.5, 26965	9.32	0.922	52.0

### Hardware Setup

Phantom	TSL, Measured Date	Probe, Calibration Date	DAE, Calibration Date
ELI V8.0 (20deg probe tilt) - 2124	MABL-600-6000, 2022-Jan-27	EX3DV4 - SN3978, 2021-05-21	DAE4 Sn1429, 2021-05-11

### Scan Setup

	Area Scan	Zoom Scan
Grid Extents [mm]	120.0 x 120.0	30.0 x 30.0 x 30.0
Grid Steps [mm]	15.0 x 15.0	6.0 x 6.0 x 1.5
Sensor Surface [mm]	3.0	1.4
Graded Grid	Yes	Yes
Grading Ratio	1.5	1.5
MAIA	Confirmed by MAIA	Confirmed by MAIA
Surface Detection	Yes	Yes
Scan Method	Measured	Measured

### Measurement Results

	Area Scan	Zoom Scan
Date	2022-01-28, 01:45	2022-01-28, 01:51
SAR1g [W/Kg]	0.871	0.868
SAR10g [W/Kg]	0.550	0.516
Power Drift [dB]	0.01	0.00
Power Scaling	Disabled	Disabled
Scaling Factor [dB]		
TSL Correction	Positive Only	Positive Only

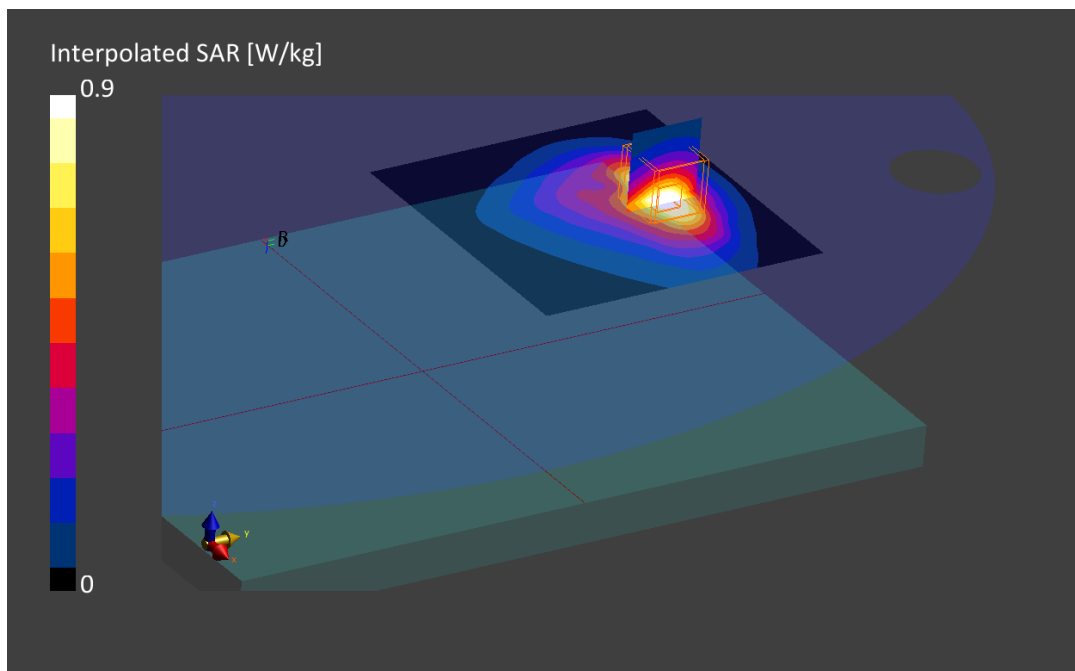

## 10. LTE Band 30, QPSK - 10MHz, CH27710, Antenna HongBo

### Device under Test Properties

Name, Manufacturer	Dimensions [mm]	S/N	DUT Type
HSN-I50C	295.0 x 220.0 x 17.0	0001760GOC	Laptop

### Exposure Conditions

Phantom Section, TSL	Position, Test Distance [mm]	Band	Group, UID	Frequency [MHz], Channel Number	Conversion Factor	TSL Conductivity [S/m]	TSL Permittivity
Flat MSL	Laptop 0.00	Band 30, E-UTRA/FDD	LTE-FDD, 10154-CAG	2310.0, 27710	7.45	1.84	50.0

### Hardware Setup

Phantom	TSL, Measured Date	Probe, Calibration Date	DAE, Calibration Date
ELI V8.0 (20deg probe tilt) - 2124	MBBL-600-6000, 2022-Jan-27	EX3DV4 - SN3978, 2021-05-21	DAE4 Sn1429, 2021-05-11

### Scan Setup

	Area Scan	Zoom Scan
Grid Extents [mm]	100.0 x 100.0	30.0 x 30.0 x 30.0
Grid Steps [mm]	10.0 x 10.0	5.0 x 5.0 x 1.5
Sensor Surface [mm]	3.0	1.4
Graded Grid	Yes	Yes
Grading Ratio	1.5	1.5
MAIA	Confirmed by MAIA	Confirmed by MAIA
Surface Detection	Yes	Yes
Scan Method	Measured	Measured

### Measurement Results

	Area Scan	Zoom Scan
Date	2022-01-28, 01:56	2022-01-28, 02:11
SAR1g [W/Kg]	0.666	0.693
SAR10g [W/Kg]	0.340	0.349
Power Drift [dB]	-0.02	0.00
Power Scaling	Disabled	Disabled
Scaling Factor [dB]		
TSL Correction	Positive Only	Positive Only

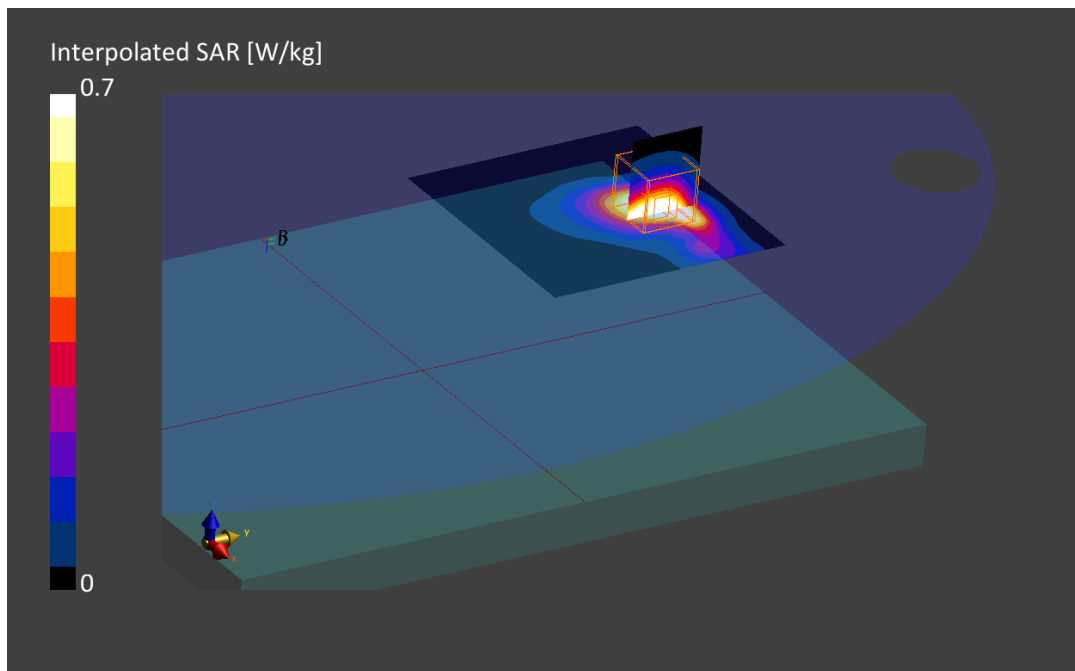

## 11. LTE Band 41, QPSK - 20MHz, CH40620, Antenna HongBo

### Device under Test Properties

Name, Manufacturer	Dimensions [mm]	S/N	DUT Type
HSN-I50C	295.0 x 220.0 x 17.0	0001760GOC	Laptop

### Exposure Conditions

Phantom Section, TSL	Position, Test Distance [mm]	Band	Group, UID	Frequency [MHz], Channel Number	Conversion Factor	TSL Conductivity [S/m]	TSL Permittivity
Flat MSL	Laptop 0.00	Band 41, E- UTRA/TDD	LTE-TDD, 10494-AAF	2593.0, 40620	7.24	2.15	49.3

### Hardware Setup

Phantom	TSL, Measured Date	Probe, Calibration Date	DAE, Calibration Date
ELI V8.0 (20deg probe tilt) - 2124	MBBL-600-6000, 2022-Jan-27	EX3DV4 - SN3978, 2021-05-21	DAE4 Sn1429, 2021-05-11

### Scan Setup

	Area Scan	Zoom Scan
Grid Extents [mm]	100.0 x 100.0	30.0 x 30.0 x 30.0
Grid Steps [mm]	10.0 x 10.0	5.0 x 5.0 x 1.5
Sensor Surface [mm]	3.0	1.4
Graded Grid	Yes	Yes
Grading Ratio	1.5	1.5
MAIA	Confirmed by MAIA	Confirmed by MAIA
Surface Detection	Yes	Yes
Scan Method	Measured	Measured

### Measurement Results

	Area Scan	Zoom Scan
Date	2022-01-28, 09:05	2022-01-28, 09:14
SAR1g [W/Kg]	0.335	0.354
SAR10g [W/Kg]	0.172	0.173
Power Drift [dB]	0.00	0.08
Power Scaling	Disabled	Disabled
Scaling Factor [dB]		
TSL Correction	Positive Only	Positive Only

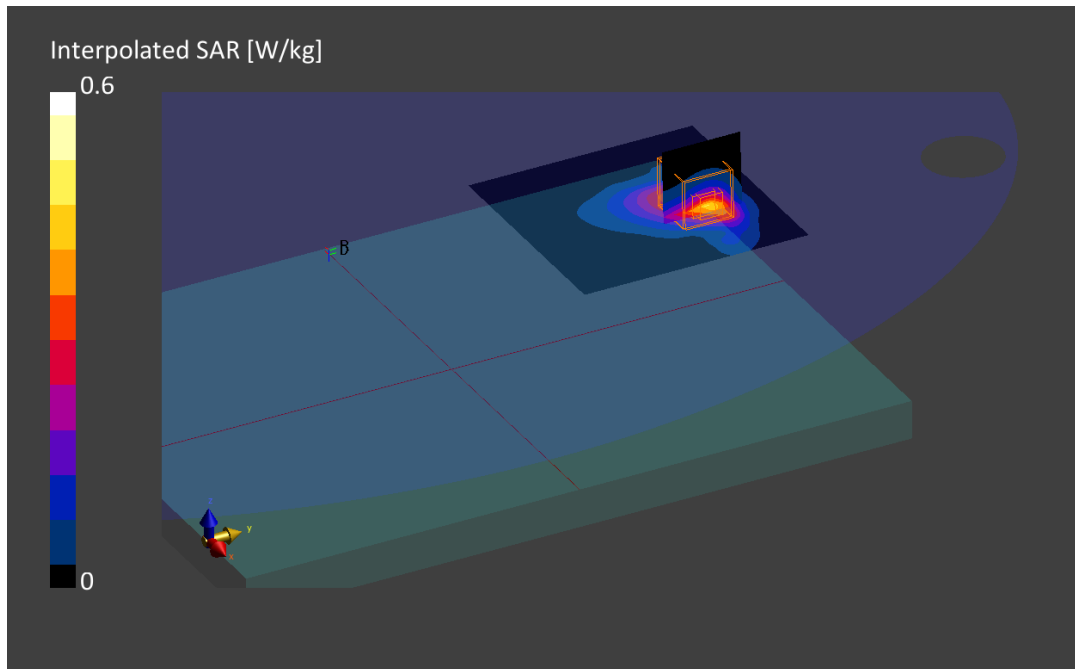

## 12. LTE Band 48, QPSK - 20MHz, CH55990, Antenna HongBo

### Device under Test Properties

Name, Manufacturer	Dimensions [mm]	S/N	DUT Type
HSN-I50C	295.0 x 220.0 x 17.0	0001760GOC	Laptop

### Exposure Conditions

Phantom Section, TSL	Position, Test Distance [mm]	Band	Group, UID	Frequency [MHz], Channel Number	Conversion Factor	TSL Conductivity [S/m]	TSL Permittivity
Flat MSL	Laptop 0.00	Band 48, E-UTRA/TDD	LTE-TDD, 10435-AAF	3625.0, 55990	6.07	3.11	47.6

### Hardware Setup

Phantom	TSL, Measured Date	Probe, Calibration Date	DAE, Calibration Date
ELI V8.0 (20deg probe tilt) - 2124	MBBL-600-6000, 2022-Jan-27	EX3DV4 - SN3978, 2021-05-21	DAE4 Sn1429, 2021-05-11

### Scan Setup

	Area Scan	Zoom Scan
Grid Extents [mm]	100.0 x 100.0	28.0 x 28.0 x 28.0
Grid Steps [mm]	10.0 x 10.0	5.0 x 5.0 x 1.4
Sensor Surface [mm]	3.0	1.4
Graded Grid	Yes	Yes
Grading Ratio	1.5	1.5
MAIA	Confirmed by MAIA	Confirmed by MAIA
Surface Detection	Yes	Yes
Scan Method	Measured	Measured

### Measurement Results

	Area Scan	Zoom Scan
Date	2022-01-28, 14:14	2022-01-28, 14:29
SAR1g [W/Kg]	0.430	0.443
SAR10g [W/Kg]	0.201	0.203
Power Drift [dB]	0.04	0.06
Power Scaling	Disabled	Disabled
Scaling Factor [dB]		
TSL Correction	Positive Only	Positive Only

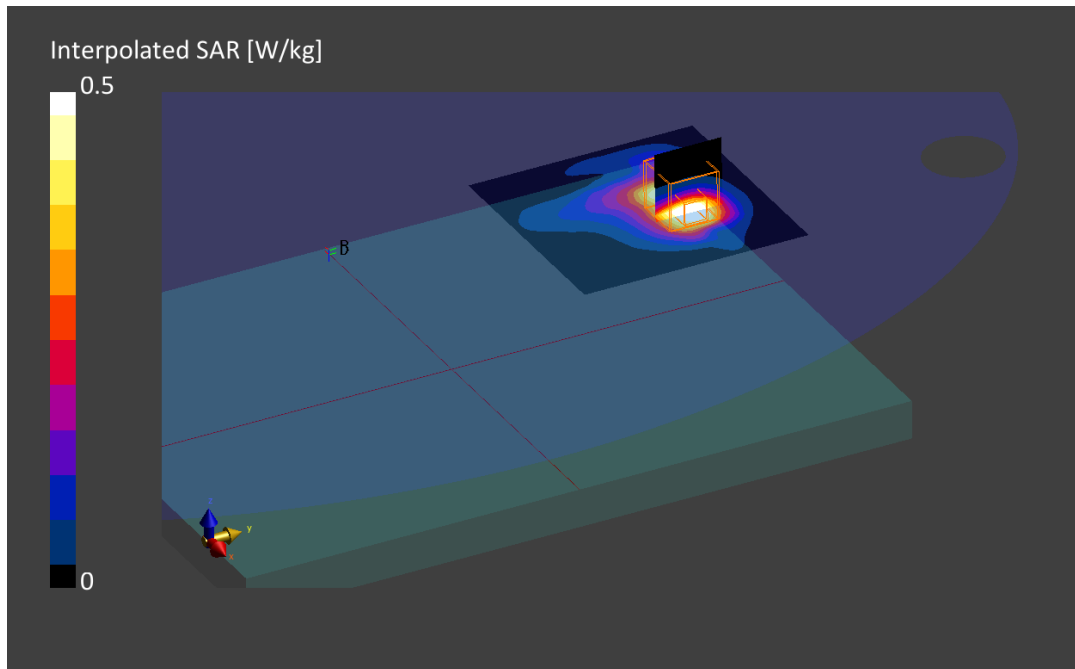

### 13. LTE Band 66, QPSK - 20MHz, CH132572, Antenna WNC

**Device under Test Properties**

Name, Manufacturer	Dimensions [mm]	S/N	DUT Type
HSN-I50C	295.0 x 220.0 x 17.0	0001760GWR	Laptop

**Exposure Conditions**

Phantom Section, TSL	Position, Test Distance [mm]	Band	Group, UID	Frequency [MHz], Channel Number	Conversion Factor	TSL Conductivity [S/m]	TSL Permittivity
Flat MSL	Laptop, 0.00	Band 66, E-UTRA/FDD	LTE-FDD, 10297-AAD	1770.0, 132572	8.37	1.50	52.1

**Hardware Setup**

Phantom	TSL, Measured Date	Probe, Calibration Date	DAE, Calibration Date
ELI V8.0 (20deg probe tilt) - 2124	MBBL-600-6000, 2022-Jan-06	EX3DV4 - SN3978, 2021-05-21	DAE4 Sn1429, 2021-05-11

**Scan Setup**

	Area Scan	Zoom Scan
Grid Extents [mm]	80.0 x 80.0	28.0 x 28.0 x 28.0
Grid Steps [mm]	10.0 x 10.0	5.0 x 5.0 x 1.4
Sensor Surface [mm]	3.0	1.4
Graded Grid	Yes	Yes
Grading Ratio	1.5	1.5
MAIA	Confirmed by MAIA	Confirmed by MAIA
Surface Detection	Yes	Yes
Scan Method	Measured	Measured

**Measurement Results**

	Area Scan	Zoom Scan
Date	2022-01-07, 20:20	2022-01-07, 20:25
SAR1g [W/Kg]	0.818	0.973
SAR10g [W/Kg]	0.446	0.497
Power Drift [dB]	-0.03	0.01
Power Scaling	Disabled	Disabled
Scaling Factor [dB]		
TSL Correction	Positive Only	Positive Only

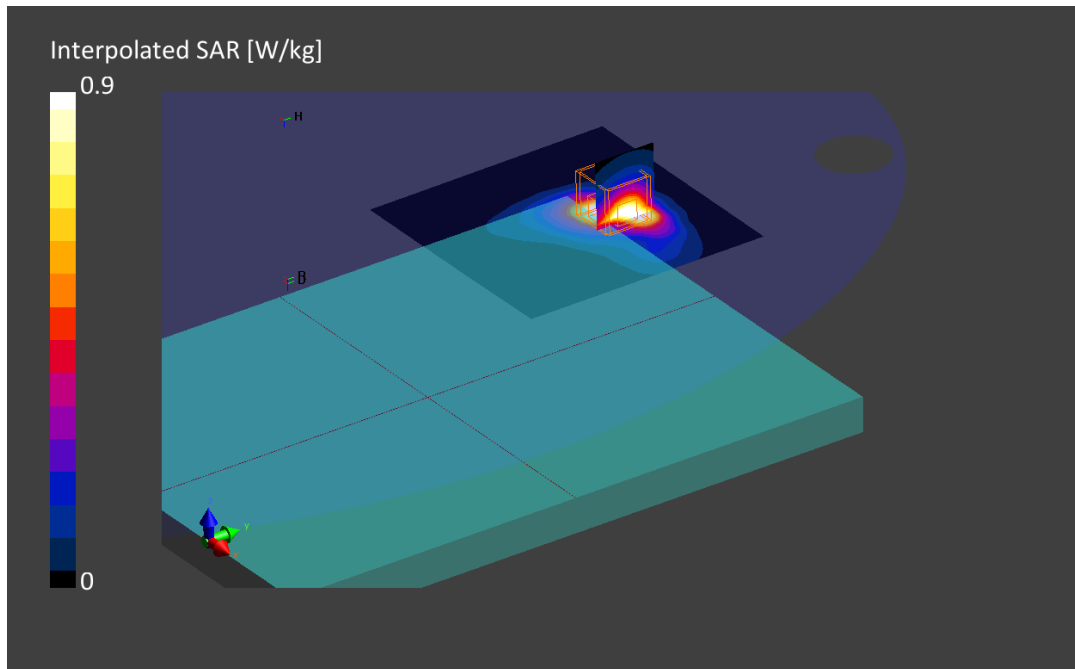

## 14. System Check Body Liquid 750MHz – 2022-01-07

### Device under Test Properties

Name, Manufacturer	Dimensions [mm]	Serial Number	DUT Type
Dipole 750MHz, SPEAG	50.0 x 10.0 x 8.0	1133	Validation Dipole

### Exposure Conditions

Phantom Section, TSL	Position, Test Distance [mm]	Band	Group, UID	Frequency [MHz], Channel Number	Conversion Factor	TSL Conductivity [S/m]	TSL Permittivity
Flat, MSL	,		, 0--	750.0, 0	9.63	0.92	53.9

### Hardware Setup

Phantom	TSL, Measured Date	Probe, Calibration Date	DAE, Calibration Date
ELI V8.0 (20deg probe tilt)	MBSL-600-6000, 2022-Jan-06	EX3DV4 - SN3978, 2021-05-21	DAE4 Sn1429, 2021-05-11

### Scan Setup

	Area Scan	Zoom Scan
Grid Extents [mm]	60.0 x 90.0	30.0 x 30.0 x 30.0
Grid Steps [mm]	15.0 x 15.0	6.0 x 6.0 x 1.5
Sensor Surface [mm]	3.0	1.4
Graded Grid	Yes	Yes
Grading Ratio	1.5	1.5
MAIA	Confirmed by MAIA	Confirmed by MAIA
Surface Detection	VMS + 6p	VMS + 6p
Scan Method	Measured	Measured

### Measurement Results

	Area Scan	Zoom Scan
Date	2022-01-07, 11:15	2022-01-07, 11:20
psSAR1g [W/kg]	0.387	0.408
psSAR10g [W/kg]	0.265	0.271
Power Drift [dB]	0.05	-0.01
Power Scaling	Disabled	Disabled
Scaling Factor [dB]		
TSL Correction	Positive Only	Positive Only
M2/M1 [%]		87.9
Dist 3dB Peak [mm]		19.7

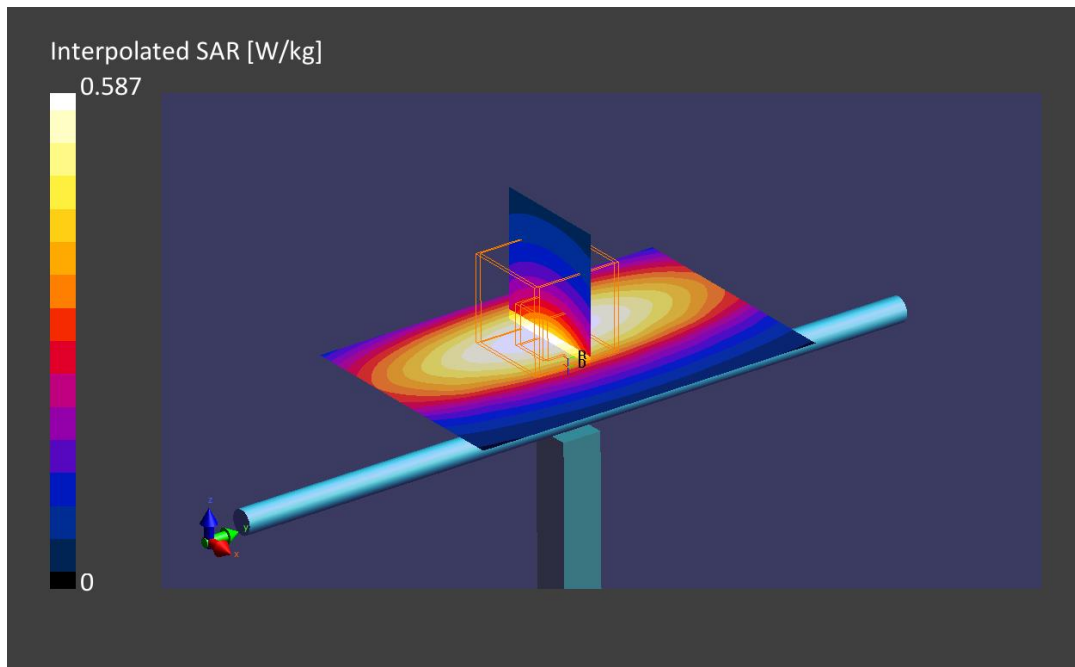



## 15. System Check Body Liquid 750MHz – 2022-01-27

### Device under Test Properties

Name, Manufacturer	Dimensions [mm]	Serial Number	DUT Type
Dipole 750MHz, SPEAG	50.0 x 10.0 x 8.0	1133	Validation Dipole

### Exposure Conditions

Phantom Section, TSL	Position, Test Distance [mm]	Band	Group, UID	Frequency [MHz], Channel Number	Conversion Factor	TSL Conductivity [S/m]	TSL Permittivity
Flat, MSL	,		, 0--	750.0, 0	9.63	0.890	52.2

### Hardware Setup

Phantom	TSL, Measured Date	Probe, Calibration Date	DAE, Calibration Date
ELI V8.0 (20deg probe tilt)	MBSL-600-6000, 2022-Jan-27	EX3DV4 - SN3978, 2021-05-21	DAE4 Sn1429, 2021-05-11

### Scan Setup

	Area Scan	Zoom Scan
Grid Extents [mm]	40.0 x 90.0	30.0 x 30.0 x 30.0
Grid Steps [mm]	10.0 x 15.0	6.0 x 6.0 x 1.5
Sensor Surface [mm]	3.0	1.4
Graded Grid	Yes	Yes
Grading Ratio	1.5	1.5
MAIA	Confirmed by MAIA	Confirmed by MAIA
Surface Detection	VMS + 6p	VMS + 6p
Scan Method	Measured	Measured

### Measurement Results

	Area Scan	Zoom Scan
Date	2022-01-27, 14:46	2022-01-27, 14:51
psSAR1g [W/kg]	0.402	0.409
psSAR10g [W/kg]	0.269	0.268
Power Drift [dB]	-0.02	0.05
Power Scaling	Disabled	Disabled
Scaling Factor [dB]		
TSL Correction	Positive Only	Positive Only
M2/M1 [%]		87.8
Dist 3dB Peak [mm]		20.4

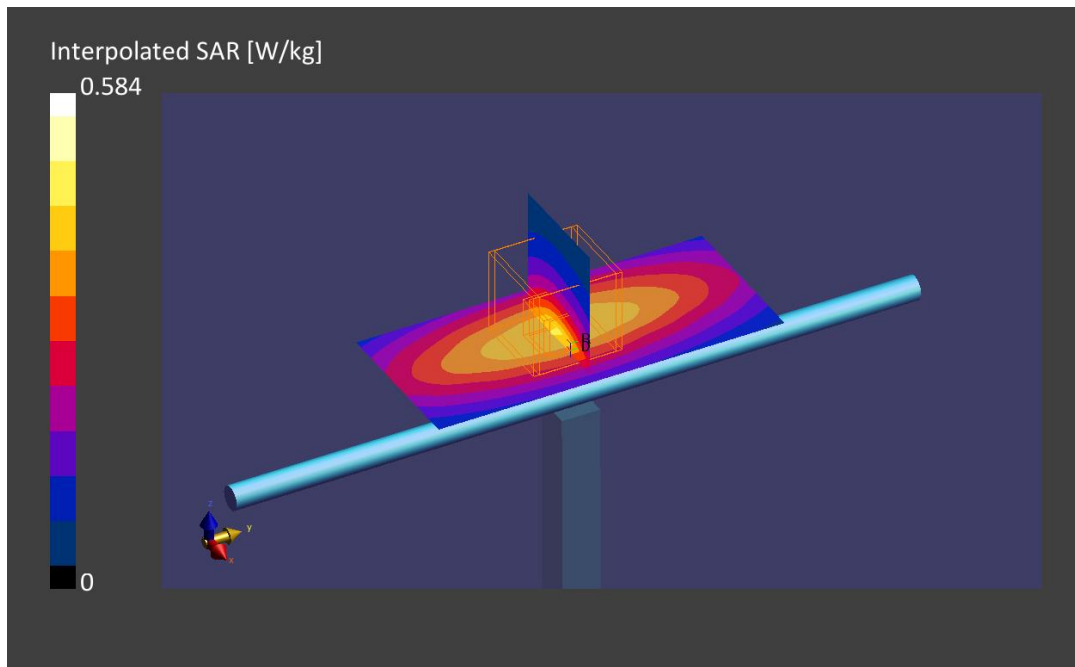

## 16. System Check Body Liquid 835MHz – 2022-01-28

### Device under Test Properties

Name, Manufacturer	Dimensions [mm]	Serial Number	DUT Type
Dipole 835MHz, SPEAG	50.0 x 10.0 x 8.0	4d192	Validation Dipole

### Exposure Conditions

Phantom Section, TSL	Position, Test Distance [mm]	Band	Group, UID	Frequency [MHz], Channel Number	Conversion Factor	TSL Conductivity [S/m]	TSL Permittivity
Flat, MSL	,		, 0--	835.0, 0	9.32	0.919	52.0

### Hardware Setup

Phantom	TSL, Measured Date	Probe, Calibration Date	DAE, Calibration Date
ELI V8.0 (20deg probe tilt)	MBSL-600-6000, 2022-Jan-27	EX3DV4 - SN3978, 2021-05-21	DAE4 Sn1429, 2021-05-11

### Scan Setup

	Area Scan	Zoom Scan
Grid Extents [mm]	40.0 x 90.0	30.0 x 30.0 x 30.0
Grid Steps [mm]	10.0 x 15.0	6.0 x 6.0 x 1.5
Sensor Surface [mm]	3.0	1.4
Graded Grid	Yes	Yes
Grading Ratio	1.5	1.5
MAIA	Confirmed by MAIA	Confirmed by MAIA
Surface Detection	VMS + 6p	VMS + 6p
Scan Method	Measured	Measured

### Measurement Results

	Area Scan	Zoom Scan
Date	2022-01-28, 15:01	2022-01-28, 15:06
psSAR1g [W/kg]	0.455	0.458
psSAR10g [W/kg]	0.299	0.302
Power Drift [dB]	0.02	0.01
Power Scaling	Disabled	Disabled
Scaling Factor [dB]		
TSL Correction	Positive Only	Positive Only
M2/M1 [%]		86.8
Dist 3dB Peak [mm]		15.8

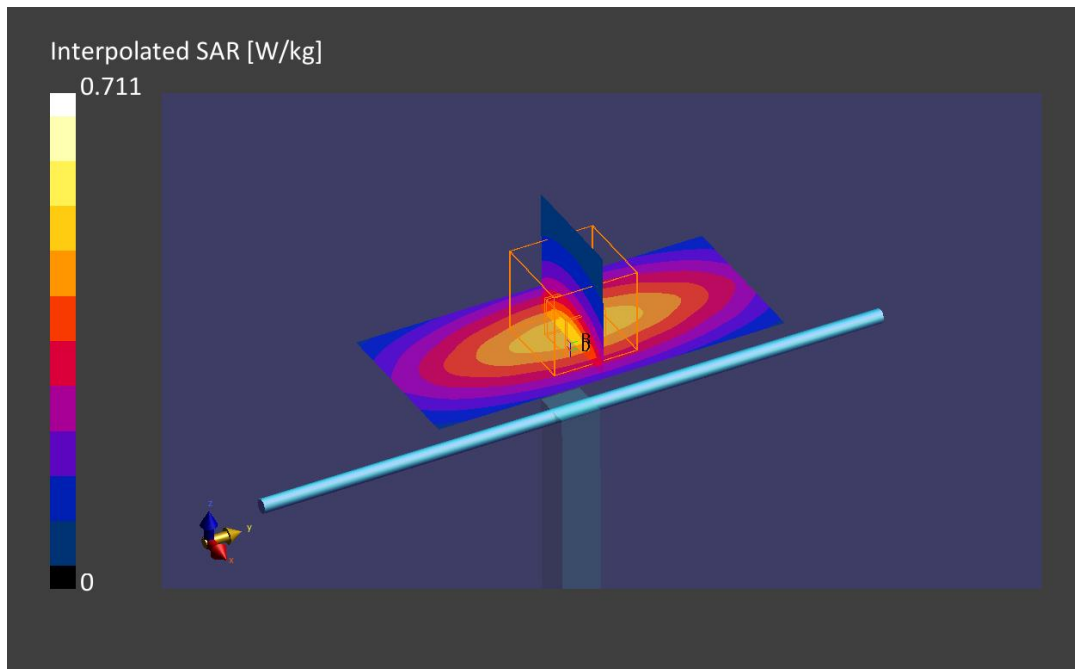

## 17. System Check Body Liquid 1750MHz – 2022-01-07

### Device under Test Properties

Name, Manufacturer	Dimensions [mm]	Serial Number	DUT Type
Dipole 1750MHz, SPEAG	50.0 x 10.0 x 20.0	1133	Validation Dipole

### Exposure Conditions

Phantom Section, TSL	Position, Test Distance [mm]	Band	Group, UID	Frequency [MHz], Channel Number	Conversion Factor	TSL Conductivity [S/m]	TSL Permittivity
Flat MSL			,	1750.0, 0	8.37	1.48	52.1

### Hardware Setup

Phantom	TSL, Measured Date	Probe, Calibration Date	DAE, Calibration Date
ELI V8.0 (20deg probe tilt) - 2124	MBBL-600-6000, 2022-Jan-06	EX3DV4 - SN3978, 2021-05-21	DAE4 Sn1429, 2021-05-11

### Scan Setup

	Area Scan	Zoom Scan
Grid Extents [mm]	60.0 x 90.0	30.0 x 30.0 x 30.0
Grid Steps [mm]	15.0 x 15.0	6.0 x 6.0 x 1.5
Sensor Surface [mm]	3.0	1.4
Graded Grid	Yes	Yes
Grading Ratio	1.5	1.5
MAIA	Confirmed by MAIA	Confirmed by MAIA
Surface Detection	Yes	Yes
Scan Method	Measured	Measured

### Measurement Results

	Area Scan	Zoom Scan
Date	2022-01-07, 12:01	2022-01-07, 12:05
psSAR1g [W/Kg]	1.44	1.69
psSAR10g [W/Kg]	0.825	0.903
Power Drift [dB]	-0.00	0.07
Power Scaling	Disabled	Disabled
Scaling Factor [dB]		
TSL Correction	Positive Only	Positive Only

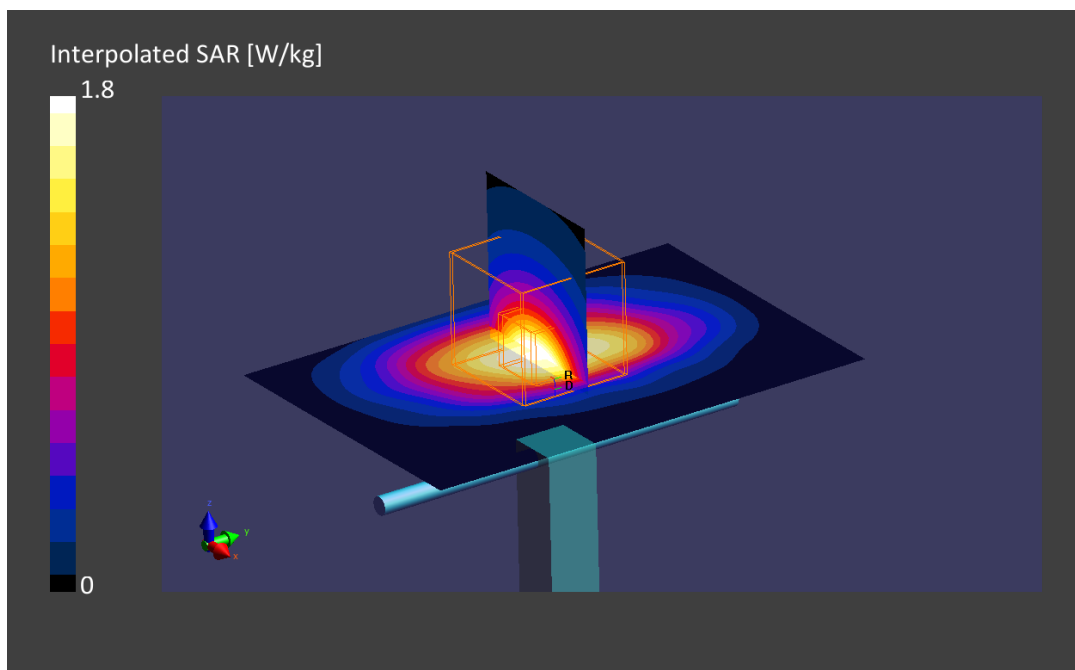

## 18. System Check Body Liquid 1750MHz – 2022-01-28

### Device under Test Properties

Name, Manufacturer	Dimensions [mm]	Serial Number	DUT Type
Dipole 1750MHz, SPEAG	50.0 x 10.0 x 8.0	1133	Validation Dipole

### Exposure Conditions

Phantom Section, TSL	Position, Test Distance [mm]	Band	Group, UID	Frequency [MHz], Channel Number	Conversion Factor	TSL Conductivity [S/m]	TSL Permittivity
Flat, MSL	,		, 0--	1750.0, 0	8.37	1.39	50.6

### Hardware Setup

Phantom	TSL, Measured Date	Probe, Calibration Date	DAE, Calibration Date
ELI V8.0 (20deg probe tilt)	MBSL-600-6000, 2022-Jan-27	EX3DV4 - SN3978, 2021-05-21	DAE4 Sn1429, 2021-05-11

### Scan Setup

	Area Scan	Zoom Scan
Grid Extents [mm]	40.0 x 90.0	30.0 x 30.0 x 30.0
Grid Steps [mm]	10.0 x 15.0	6.0 x 6.0 x 1.5
Sensor Surface [mm]	3.0	1.4
Graded Grid	Yes	Yes
Grading Ratio	1.5	1.5
MAIA	Confirmed by MAIA	Confirmed by MAIA
Surface Detection	VMS + 6p	VMS + 6p
Scan Method	Measured	Measured

### Measurement Results

	Area Scan	Zoom Scan
Date	2022-01-28, 15:13	2022-01-28, 15:18
psSAR1g [W/kg]	1.67	1.69
psSAR10g [W/kg]	0.884	0.905
Power Drift [dB]	0.02	0.05
Power Scaling	Disabled	Disabled
Scaling Factor [dB]		
TSL Correction	Positive Only	Positive Only
M2/M1 [%]		82.6
Dist 3dB Peak [mm]		10.3

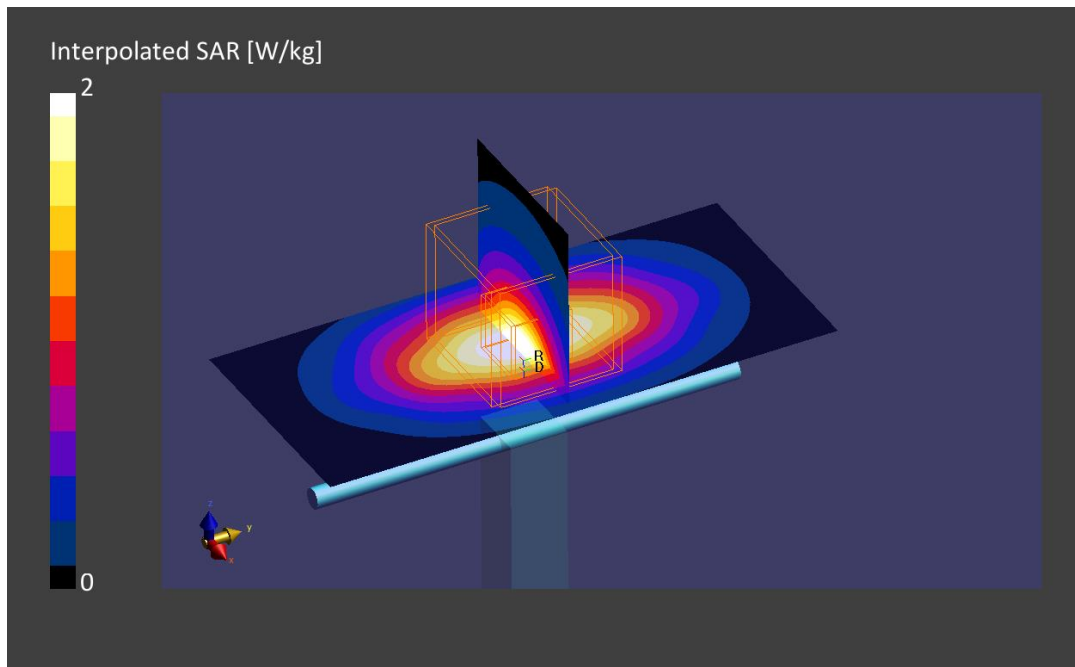

## 19. System Check Body Liquid 1900MHz

### Device under Test Properties

Name, Manufacturer	Dimensions [mm]	S/N	DUT Type
Dipole 1900MHz, SPEAG	50.0 x 10.0 x 8.0	5d197	Validation Dipole

### Exposure Conditions

Phantom Section, TSL	Position, Test Distance [mm]	Band	Group, UID	Frequency [MHz], Channel Number	Conversion Factor	TSL Conductivity [S/m]	TSL Permittivity
Flat, MSL	,		, 0--	1900.0, 0	7.98	1.49	50.5

### Hardware Setup

Phantom	TSL, Measured Date	Probe, Calibration Date	DAE, Calibration Date
ELI V8.0 (20deg probe tilt)	MABL-600-6000, 2022-Jan-27	EX3DV4 - SN3978, 2021-05-21	DAE4 Sn1429, 2021-05-11

### Scan Setup

	Area Scan	Zoom Scan
Grid Extents [mm]	40.0 x 90.0	30.0 x 30.0 x 30.0
Grid Steps [mm]	10.0 x 15.0	6.0 x 6.0 x 1.5
Sensor Surface [mm]	3.0	1.4
Graded Grid	Yes	Yes
Grading Ratio	1.5	1.5
MAIA	Confirmed by MAIA	Confirmed by MAIA
Surface Detection	VMS + 6p	VMS + 6p
Scan Method	Measured	Measured

### Measurement Results

	Area Scan	Zoom Scan
Date	2022-01-28, 15:24	2022-01-28, 15:29
psSAR1g [W/kg]	1.89	1.92
psSAR10g [W/kg]	0.967	1.00
Power Drift [dB]	-0.02	0.15
Power Scaling	Disabled	Disabled
Scaling Factor [dB]		
TSL Correction	Positive Only	Positive Only
M2/M1 [%]		82.9
Dist 3dB Peak [mm]		9.6

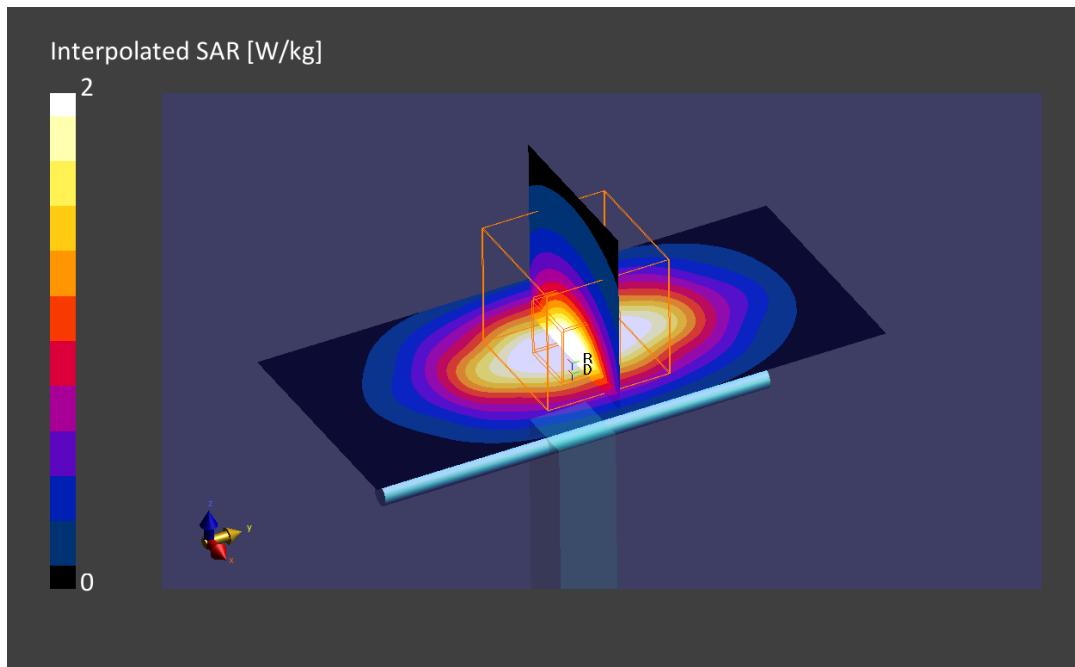

## 20. System Check Body Liquid 2300MHz

**Device under Test Properties**

Name, Manufacturer	Dimensions [mm]	Serial Number	DUT Type
D2300MHZ, SPEAG	50.0 x 10.0 x 8.0	1046	Validation Dipole

**Exposure Conditions**

Phantom Section, TSL	Position, Test Distance [mm]	Band	Group, UID	Frequency [MHz], Channel Number	Conversion Factor	TSL Conductivity [S/m]	TSL Permittivity
Flat, MSL	,	,	0--	2300.0, 0	7.45	1.83	50.0

**Hardware Setup**

Phantom	TSL, Measured Date	Probe, Calibration Date	DAE, Calibration Date
ELI V8.0 (20deg probe tilt)	MABL-600-6000, 2022-Jan-27	EX3DV4 - SN3978, 2021-05-21	DAE4 Sn1429, 2021-05-11

**Scan Setup**

	Area Scan	Zoom Scan
Grid Extents [mm]	40.0 x 80.0	30.0 x 30.0 x 30.0
Grid Steps [mm]	10.0 x 10.0	5.0 x 5.0 x 1.5
Sensor Surface [mm]	3.0	1.4
Graded Grid	Yes	Yes
Grading Ratio	1.5	1.5
MAIA	Confirmed by MAIA	Confirmed by MAIA
Surface Detection	VMS + 6p	VMS + 6p
Scan Method	Measured	Measured

**Measurement Results**

	Area Scan	Zoom Scan
Date	2022-01-28, 15:35	2022-01-28, 15:42
psSAR1g [W/kg]	2.32	2.37
psSAR10g [W/kg]	1.12	1.14
Power Drift [dB]	-0.03	0.09
Power Scaling	Disabled	Disabled
Scaling Factor [dB]		
TSL Correction	Positive Only	Positive Only
M2/M1 [%]		81.2
Dist 3dB Peak [mm]		9.0

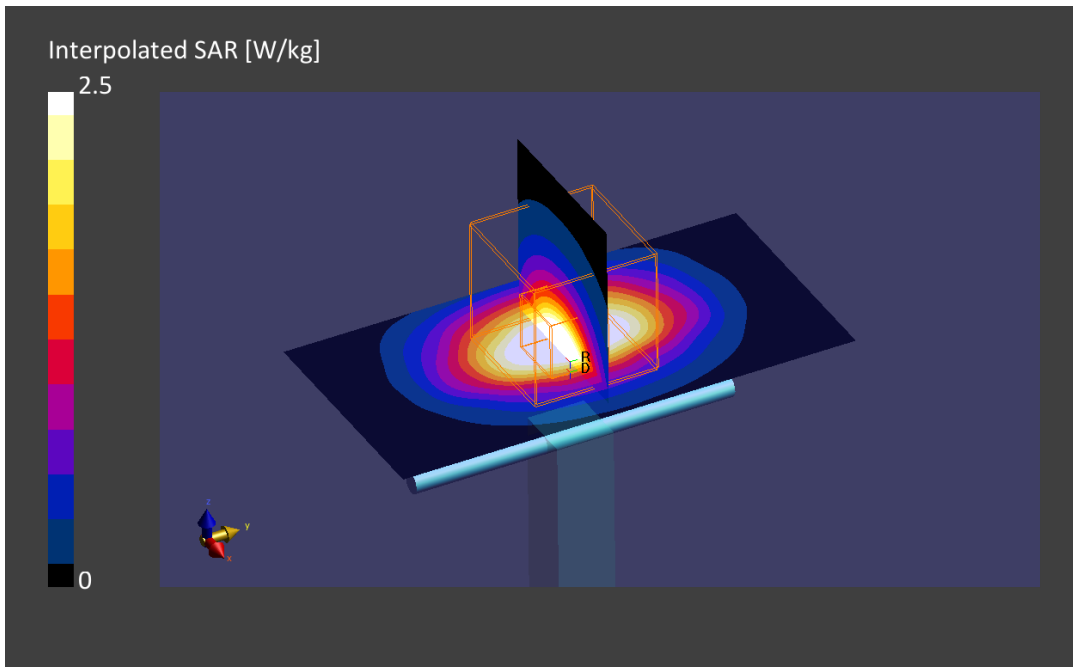

## 21. System Check Body Liquid 2600MHz

### Device under Test Properties

Name, Manufacturer	Dimensions [mm]	Serial Number	DUT Type
D2600MHz, SPEAG	50.0 x 10.0 x 8.0	1100	Validation Dipole

### Exposure Conditions

Phantom Section, TSL	Position, Test Distance [mm]	Band	Group, UID	Frequency [MHz], Channel Number	Conversion Factor	TSL Conductivity [S/m]	TSL Permittivity
Flat, MSL	,	,	0--	2600.0, 0	7.24	2.08	49.5

### Hardware Setup

Phantom	TSL, Measured Date	Probe, Calibration Date	DAE, Calibration Date
ELI V8.0 (20deg probe tilt)	MABL-600-6000, 2022-Jan-27	EX3DV4 - SN3978, 2021-05-21	DAE4 Sn1429, 2021-05-11

### Scan Setup

	Area Scan	Zoom Scan
Grid Extents [mm]	40.0 x 80.0	30.0 x 30.0 x 30.0
Grid Steps [mm]	10.0 x 10.0	5.0 x 5.0 x 1.5
Sensor Surface [mm]	3.0	1.4
Graded Grid	Yes	Yes
Grading Ratio	1.5	1.5
MAIA	Confirmed by MAIA	Confirmed by MAIA
Surface Detection	VMS + 6p	VMS + 6p
Scan Method	Measured	Measured

### Measurement Results

	Area Scan	Zoom Scan
Date	2022-01-27, 15:48	2022-01-27, 15:54
psSAR1g [W/kg]	2.63	2.62
psSAR10g [W/kg]	1.16	1.18
Power Drift [dB]	0.01	0.02
Power Scaling	Disabled	Disabled
Scaling Factor [dB]		
TSL Correction	Positive Only	Positive Only
M2/M1 [%]		81.2
Dist 3dB Peak [mm]		8.2

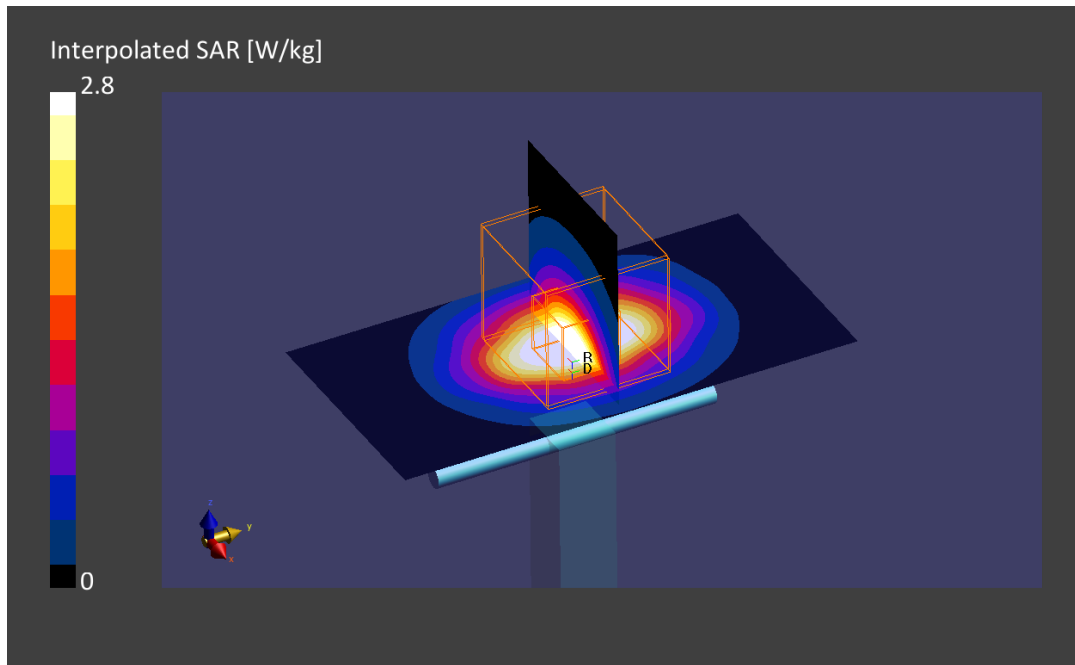

## 22. System Check Body Liquid 3700MHz

### Device under Test Properties

Name, Manufacturer	Dimensions [mm]	Serial Number	DUT Type
D2600MHz, SPEAG	50.0 x 10.0 x 17.0	1093	Validation Dipole

### Exposure Conditions

Phantom Section, TSL	Position, Test Distance [mm]	Band	Group, UID	Frequency [MHz], Channel Number	Conversion Factor	TSL Conductivity [S/m]	TSL Permittivity
Flat, MSL	,	,	0--	3700.0, 0	6.07	3.21	47.4

### Hardware Setup

Phantom	TSL, Measured Date	Probe, Calibration Date	DAE, Calibration Date
ELI V8.0 (20deg probe tilt) -	MABL-600-6000, 2022-Jan-27	EX3DV4 - SN3978, 2021-05-21	DAE4 Sn1429, 2021-05-11

### Scan Setup

	Area Scan	Zoom Scan
Grid Extents [mm]	40.0 x 80.0	28.0 x 28.0 x 28.0
Grid Steps [mm]	10.0 x 10.0	5.0 x 5.0 x 1.4
Sensor Surface [mm]	3.0	1.4
Graded Grid	Yes	Yes
Grading Ratio	1.5	1.5
MAIA	Confirmed by MAIA	Confirmed by MAIA
Surface Detection	VMS + 6p	VMS + 6p
Scan Method	Measured	Measured

### Measurement Results

	Area Scan	Zoom Scan
Date	2022-01-28, 16:00	2022-01-28, 16:07
psSAR1g [W/kg]	3.08	3.05
psSAR10g [W/kg]	1.12	1.13
Power Drift [dB]	-0.03	0.13
Power Scaling	Disabled	Disabled
Scaling Factor		
[dB]		
TSL Correction	Positive Only	Positive Only
M2/M1 [%]		77.2
Dist 3dB Peak [mm]		8.0

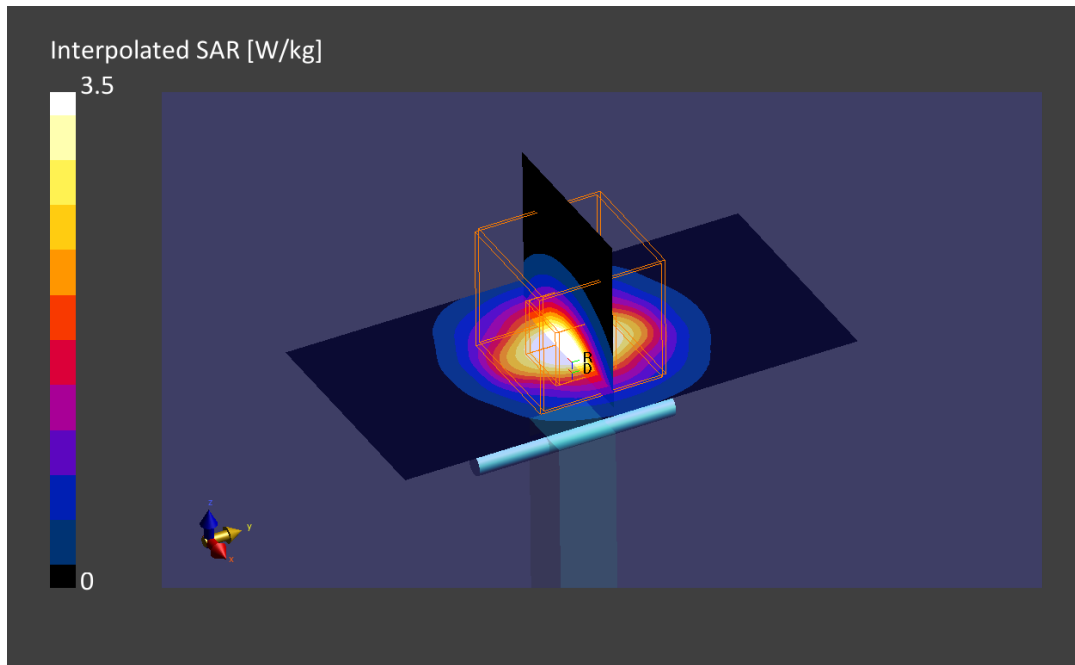



# Annex D. TSL Dielectric Parameters

## D.1 Body 700MHz-900MHz SAR

Freq. (MHz)	Target		2022-01-06		2022-01-27	
			Mea sured			
	$\epsilon'$ (F/m)	$\sigma$ (S/m)	$\epsilon'_1$ (F/m)	$\sigma_1$ (S/m)	$\epsilon'_2$ (F/m)	$\sigma_2$ (S/m)
700	55.73	0.96	54.09	0.9	52.3	0.87
710	55.69	0.96	54.05	0.91	52.28	0.88
720	55.65	0.96	54.02	0.91	52.26	0.88
730	55.61	0.96	53.99	0.92	52.25	0.88
740	55.57	0.96	53.96	0.92	52.23	0.89
750	55.53	0.96	53.92	0.92	52.21	0.89
760	55.49	0.96	53.89	0.93	52.2	0.89
770	55.45	0.96	53.86	0.93	52.18	0.9
780	55.41	0.97	53.82	0.94	52.16	0.9
790	55.38	0.97	53.79	0.94	52.15	0.9
800	55.34	0.97	53.75	0.95	52.13	0.91
810	55.3	0.97	53.71	0.95	52.11	0.91
820	55.26	0.98	53.68	0.95	52.08	0.91
830	55.23	0.98	53.64	0.96	52.06	0.92
840	55.19	0.98	53.61	0.96	52.03	0.92
850	55.15	0.99	53.57	0.97	52.0	0.93
860	55.12	1.0	53.54	0.97	51.97	0.93
870	55.09	1.01	53.5	0.98	51.95	0.93
880	55.06	1.03	53.47	0.98	51.92	0.94
890	55.03	1.04	53.44	0.98	51.9	0.94
900	55.0	1.05	53.41	0.99	51.87	0.95

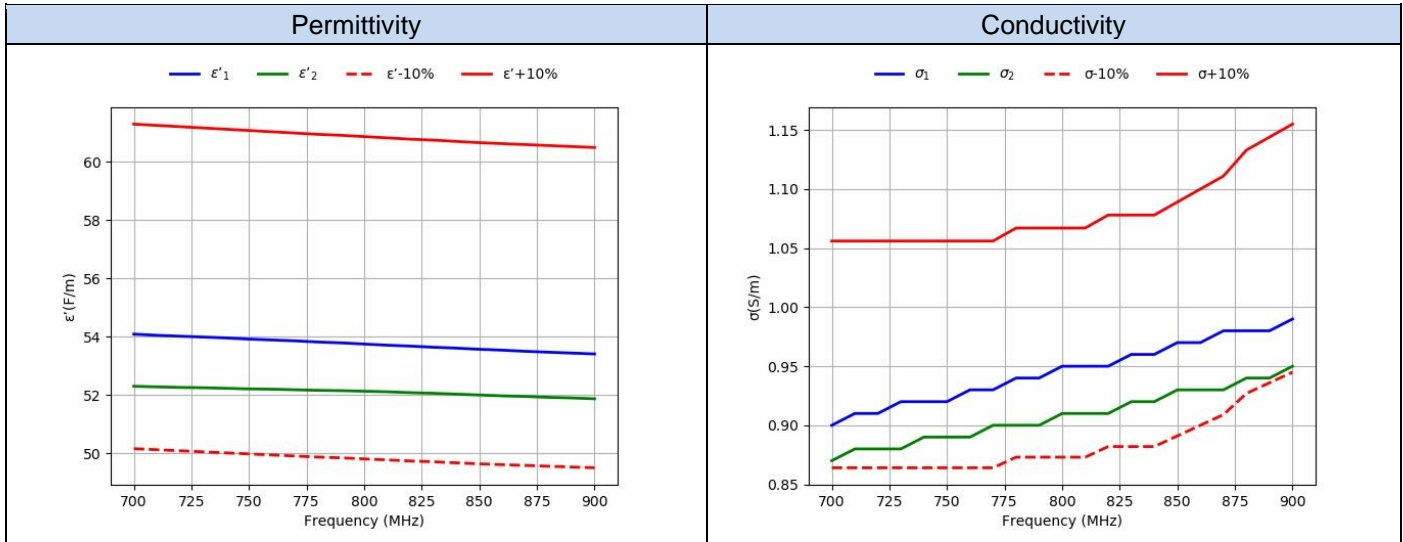

**D.2 Body 1700MHz-1950MHz SAR**

Freq. (MHz)	Target		2022-01-06		2022-01-27	
	$\epsilon'$ (F/m)	$\sigma$ (S/m)	Measured			
			$\epsilon'_1$ (F/m)	$\sigma_1$ (S/m)	$\epsilon'_2$ (F/m)	$\sigma_2$ (S/m)
1700	53.56	1.46	52.07	1.45	50.62	1.36
1710	53.54	1.46	52.06	1.46	50.61	1.37
1720	53.51	1.47	52.06	1.46	50.59	1.38
1730	53.48	1.48	52.06	1.47	50.58	1.38
1740	53.46	1.48	52.06	1.48	50.56	1.39
1750	53.43	1.49	52.06	1.48	50.55	1.39
1760	53.41	1.49	52.06	1.49	50.54	1.4
1770	53.38	1.5	52.05	1.5	50.53	1.41
1780	53.35	1.51	52.05	1.51	50.52	1.41
1790	53.33	1.51	52.04	1.51	50.51	1.42
1800	53.3	1.52	52.02	1.52	50.51	1.43
1810	53.3	1.52	52.0	1.53	50.5	1.43
1820	53.3	1.52	51.98	1.54	50.5	1.44
1830	53.3	1.52	51.97	1.54	50.49	1.45
1840	53.3	1.52	51.95	1.55	50.49	1.45
1850	53.3	1.52	51.93	1.56	50.5	1.46
1860	53.3	1.52	51.92	1.57	50.5	1.46
1870	53.3	1.52	51.9	1.57	50.51	1.47
1880	53.3	1.52	51.89	1.58	50.52	1.47
1890	53.3	1.52	51.87	1.59	50.54	1.48
1900	53.3	1.52	51.86	1.6	50.55	1.49
1910	53.3	1.52	51.85	1.6	50.56	1.49
1920	53.3	1.52	51.84	1.61	50.56	1.5
1930	53.3	1.52	51.82	1.62	50.56	1.5
1940	53.3	1.52	51.8	1.63	50.55	1.51
1950	53.3	1.52	51.79	1.63	50.54	1.51

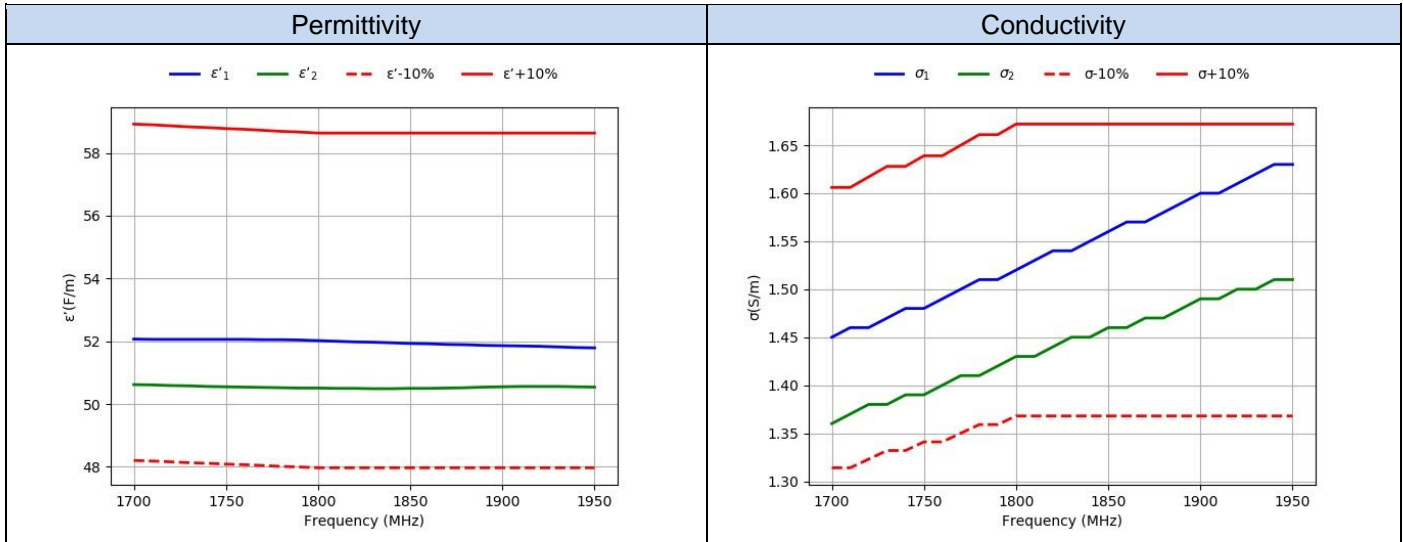

**D.3 Body 2300MHz-2700MHz**

			2022-01-27	
Target			Measured	
Freq.(MHz)	e' (F/m)	s (S/m)	e'1 (F/m)	s1 (S/m)
2300	52.9	1.81	49.98	1.83
2310	52.89	1.82	49.98	1.84
2320	52.87	1.83	49.97	1.85
2330	52.86	1.84	49.96	1.86
2340	52.85	1.84	49.95	1.87
2350	52.83	1.85	49.94	1.88
2360	52.82	1.86	49.92	1.89
2370	52.81	1.87	49.91	1.9
2380	52.79	1.88	49.89	1.91
2390	52.78	1.89	49.88	1.92
2400	52.77	1.9	49.86	1.93
2410	52.75	1.91	49.84	1.94
2420	52.74	1.92	49.83	1.95
2430	52.73	1.93	49.81	1.96
2440	52.71	1.94	49.79	1.97
2450	52.7	1.95	49.77	1.98
2460	52.69	1.96	49.75	1.98
2470	52.67	1.98	49.73	1.99
2480	52.66	1.99	49.71	2.0
2490	52.65	2.01	49.69	2.01
2500	52.64	2.02	49.66	2.01
2510	52.62	2.04	49.64	2.02
2520	52.61	2.05	49.62	2.03
2530	52.6	2.06	49.6	2.03
2540	52.59	2.08	49.58	2.04
2550	52.57	2.09	49.56	2.05
2560	52.56	2.11	49.54	2.05
2570	52.55	2.12	49.52	2.06
2580	52.53	2.13	49.5	2.07
2590	52.52	2.15	49.48	2.08
2600	52.51	2.16	49.46	2.08
2610	52.5	2.18	49.44	2.09
2620	52.48	2.19	49.42	2.1
2630	52.47	2.21	49.4	2.11
2640	52.46	2.22	49.38	2.12
2650	52.45	2.23	49.36	2.13
2660	52.43	2.25	49.34	2.14
2670	52.42	2.26	49.31	2.14
2680	52.41	2.28	49.29	2.15
2690	52.39	2.29	49.26	2.16
2700	52.38	2.3	49.24	2.17

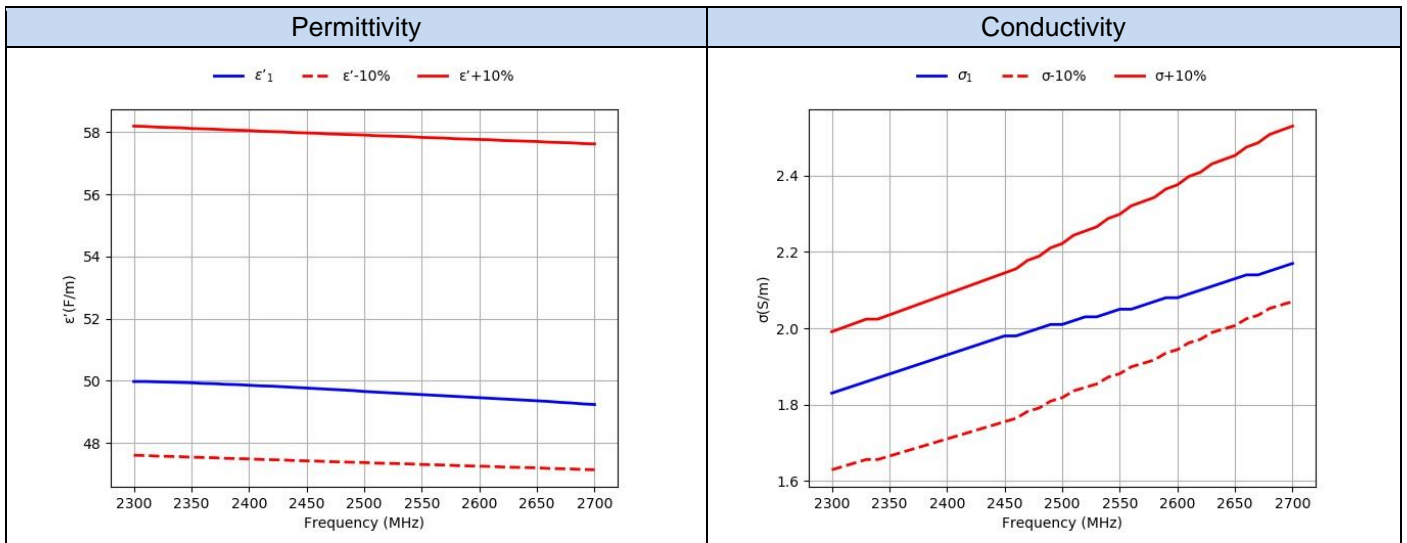

**D.4 Body 3500MHz-3900MHz**

			2022-01-27	
Target			Measured	
Freq.(MHz)	e' (F/m)	s (S/m)	e'1 (F/m)	s1 (S/m)
3500.0	51.32	3.31	47.83	2.99
3510.0	51.31	3.33	47.81	3.0
3520.0	51.29	3.34	47.79	3.01
3530.0	51.28	3.35	47.77	3.02
3540.0	51.27	3.36	47.75	3.03
3550.0	51.25	3.37	47.73	3.04
3560.0	51.24	3.38	47.71	3.05
3570.0	51.23	3.4	47.69	3.06
3580.0	51.21	3.41	47.66	3.07
3590.0	51.2	3.42	47.64	3.08
3600.0	51.19	3.43	47.62	3.09
3610.0	51.17	3.44	47.6	3.1
3620.0	51.16	3.45	47.58	3.11
3630.0	51.15	3.47	47.56	3.12
3640.0	51.13	3.48	47.54	3.13
3650.0	51.12	3.49	47.52	3.15
3660.0	51.1	3.5	47.5	3.16
3670.0	51.09	3.51	47.47	3.17
3680.0	51.08	3.52	47.45	3.18
3690.0	51.06	3.54	47.43	3.19
3700.0	51.05	3.55	47.41	3.21
3710.0	51.04	3.56	47.4	3.22
3720.0	51.02	3.57	47.38	3.23
3730.0	51.01	3.58	47.37	3.25
3740.0	51.0	3.59	47.36	3.26
3750.0	50.98	3.61	47.35	3.27
3760.0	50.97	3.62	47.34	3.28
3770.0	50.95	3.63	47.33	3.3
3780.0	50.94	3.64	47.32	3.31
3790.0	50.93	3.65	47.3	3.32
3800.0	50.91	3.66	47.29	3.33
3810.0	50.9	3.68	47.27	3.34
3820.0	50.89	3.69	47.26	3.35
3830.0	50.87	3.7	47.24	3.37
3840.0	50.86	3.71	47.22	3.38
3850.0	50.85	3.72	47.21	3.39
3860.0	50.83	3.73	47.19	3.4
3870.0	50.82	3.75	47.18	3.41
3880.0	50.81	3.76	47.16	3.43
3890.0	50.79	3.77	47.15	3.44
3900.0	50.78	3.78	47.14	3.45

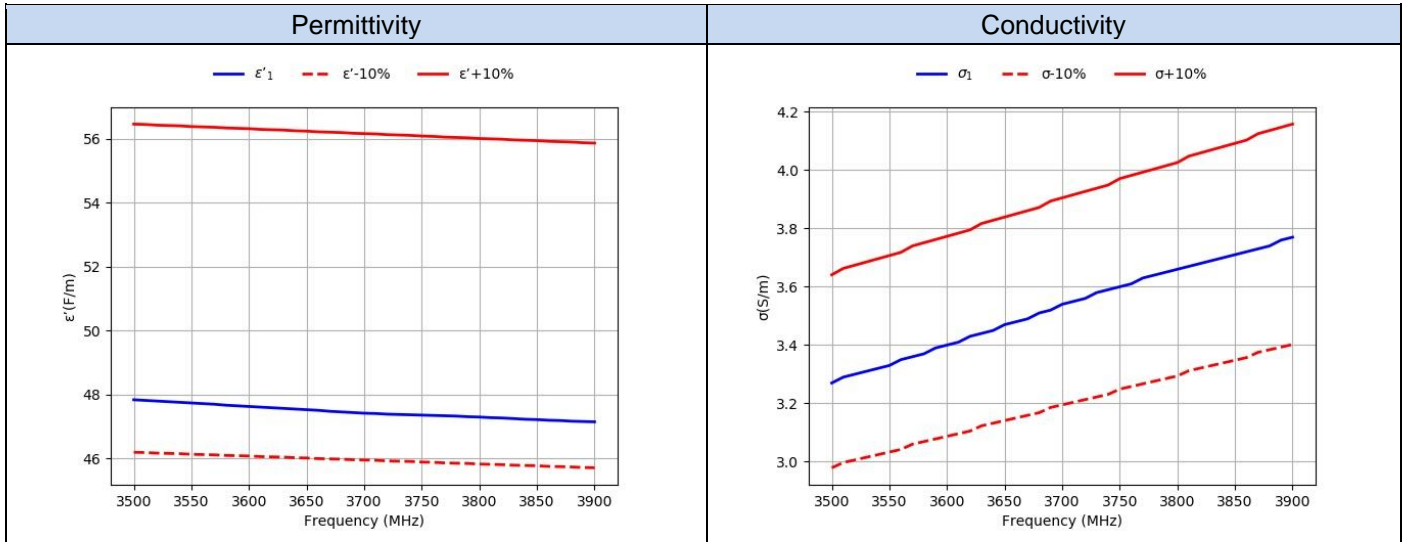



**D.5 Body 1700MHz-2000MHz**

Freq. (MHz)	Target		2022-01-19		2022-01-24	
	$\epsilon'$ (F/m)	$\sigma$ (S/m)	Measured			
			$\epsilon'_1$ (F/m)	$\sigma_1$ (S/m)	$\epsilon'_2$ (F/m)	$\sigma_2$ (S/m)
1700	53.56	1.46	51.59	1.45	50.94	1.45
1710	53.54	1.46	51.56	1.46	50.92	1.46
1720	53.51	1.47	51.55	1.47	50.91	1.47
1730	53.48	1.48	51.54	1.47	50.9	1.47
1740	53.46	1.48	51.54	1.48	50.89	1.48
1750	53.43	1.49	51.54	1.49	50.88	1.49
1760	53.41	1.49	51.55	1.49	50.88	1.49
1770	53.38	1.5	51.57	1.5	50.88	1.5
1780	53.35	1.51	51.58	1.51	50.87	1.51
1790	53.33	1.51	51.58	1.51	50.86	1.51
1800	53.3	1.52	51.59	1.52	50.85	1.52
1810	53.3	1.52	51.58	1.53	50.84	1.53
1820	53.3	1.52	51.57	1.53	50.82	1.53
1830	53.3	1.52	51.56	1.54	50.8	1.54
1840	53.3	1.52	51.54	1.55	50.78	1.54
1850	53.3	1.52	51.52	1.55	50.76	1.55
1860	53.3	1.52	51.49	1.56	50.74	1.56
1870	53.3	1.52	51.48	1.57	50.73	1.56
1880	53.3	1.52	51.46	1.58	50.72	1.57
1890	53.3	1.52	51.45	1.58	50.71	1.58
1900	53.3	1.52	51.45	1.59	50.7	1.58
1910	53.3	1.52	51.45	1.6	50.69	1.59
1920	53.3	1.52	51.45	1.61	50.67	1.6
1930	53.3	1.52	51.44	1.62	50.66	1.6
1940	53.3	1.52	51.43	1.63	50.63	1.61
1950	53.3	1.52	51.41	1.64	50.6	1.62
1960	53.3	1.52	51.39	1.64	50.57	1.62
1970	53.3	1.52	51.37	1.65	50.54	1.63
1980	53.3	1.52	51.35	1.66	50.51	1.63
1990	53.3	1.52	51.34	1.66	50.49	1.64
2000	53.3	1.52	51.33	1.67	50.47	1.65

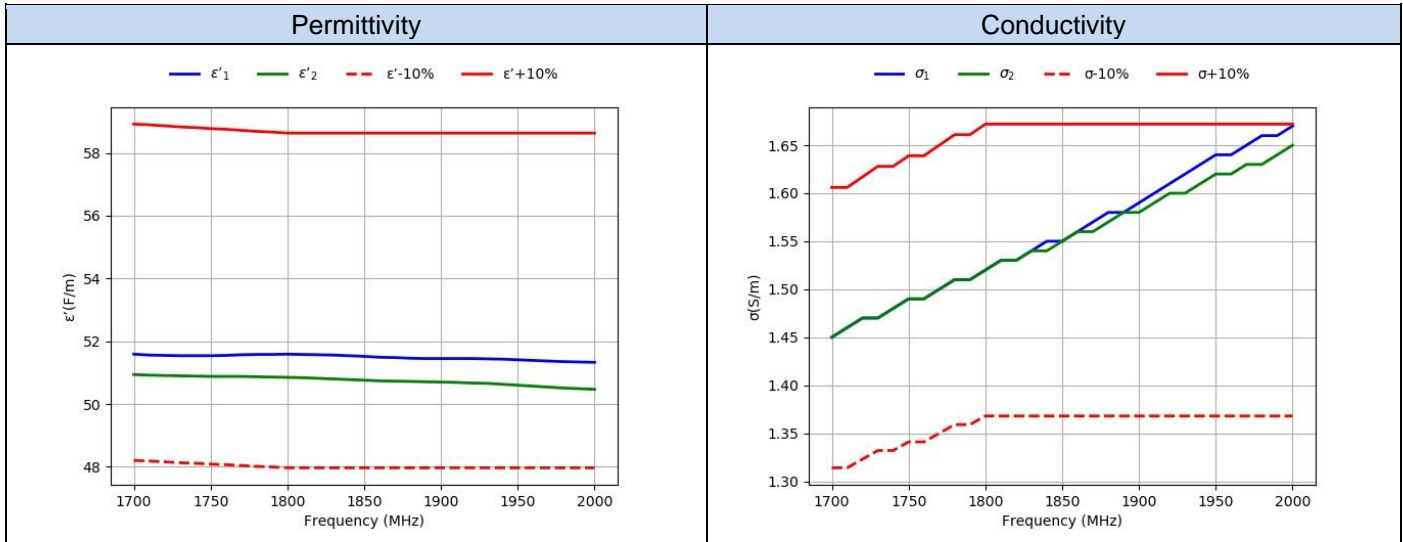

**D.6 Body 2300MHz-2700MHz**

Freq.(MHz)	Target		2022-01-19		2022-01-24	
	Target		Measured			
	e' (F/m)	s (S/m)	e'1 (F/m)	s1 (S/m)	ε'2 (F/m)	σ2 (S/m)
2300	52.9	1.81	50.8	1.91	50.21	1.85
2310	52.89	1.82	50.79	1.92	50.21	1.86
2320	52.87	1.83	50.79	1.93	50.21	1.87
2330	52.86	1.84	50.78	1.93	50.21	1.88
2340	52.85	1.84	50.78	1.94	50.2	1.89
2350	52.83	1.85	50.77	1.95	50.2	1.9
2360	52.82	1.86	50.76	1.96	50.2	1.91
2370	52.81	1.87	50.75	1.97	50.19	1.92
2380	52.79	1.88	50.74	1.98	50.19	1.92
2390	52.78	1.89	50.73	1.99	50.19	1.93
2400	52.77	1.9	50.72	1.99	50.19	1.94
2410	52.75	1.91	50.7	2.0	50.18	1.95
2420	52.74	1.92	50.68	2.01	50.18	1.96
2430	52.73	1.93	50.66	2.02	50.17	1.97
2440	52.71	1.94	50.64	2.03	50.17	1.98
2450	52.7	1.95	50.61	2.04	50.16	1.99
2460	52.69	1.96	50.59	2.05	50.15	2.0
2470	52.67	1.98	50.57	2.06	50.13	2.01
2480	52.66	1.99	50.55	2.07	50.12	2.03
2490	52.65	2.01	50.53	2.08	50.11	2.04
2500	52.64	2.02	50.51	2.1	50.09	2.05
2510	52.62	2.04	50.5	2.1	50.07	2.06
2520	52.61	2.05	50.48	2.11	50.06	2.07
2530	52.6	2.06	50.47	2.12	50.04	2.08
2540	52.59	2.08	50.46	2.13	50.03	2.09
2550	52.57	2.09	50.45	2.14	50.01	2.1
2560	52.56	2.11	50.44	2.15	49.99	2.11
2570	52.55	2.12	50.42	2.16	49.97	2.12
2580	52.53	2.13	50.41	2.16	49.96	2.13
2590	52.52	2.15	50.39	2.17	49.94	2.14
2600	52.51	2.16	50.37	2.18	49.92	2.16
2610	52.5	2.18	50.35	2.19	49.9	2.17
2620	52.48	2.19	50.33	2.2	49.88	2.18
2630	52.47	2.21	50.31	2.21	49.86	2.19
2640	52.46	2.22	50.29	2.22	49.84	2.2
2650	52.45	2.23	50.28	2.23	49.82	2.21
2660	52.43	2.25	50.26	2.24	49.8	2.22
2670	52.42	2.26	50.24	2.25	49.78	2.23
2680	52.41	2.28	50.23	2.26	49.76	2.24
2690	52.39	2.29	50.22	2.27	49.74	2.25
2700	52.38	2.3	50.21	2.28	49.72	2.26

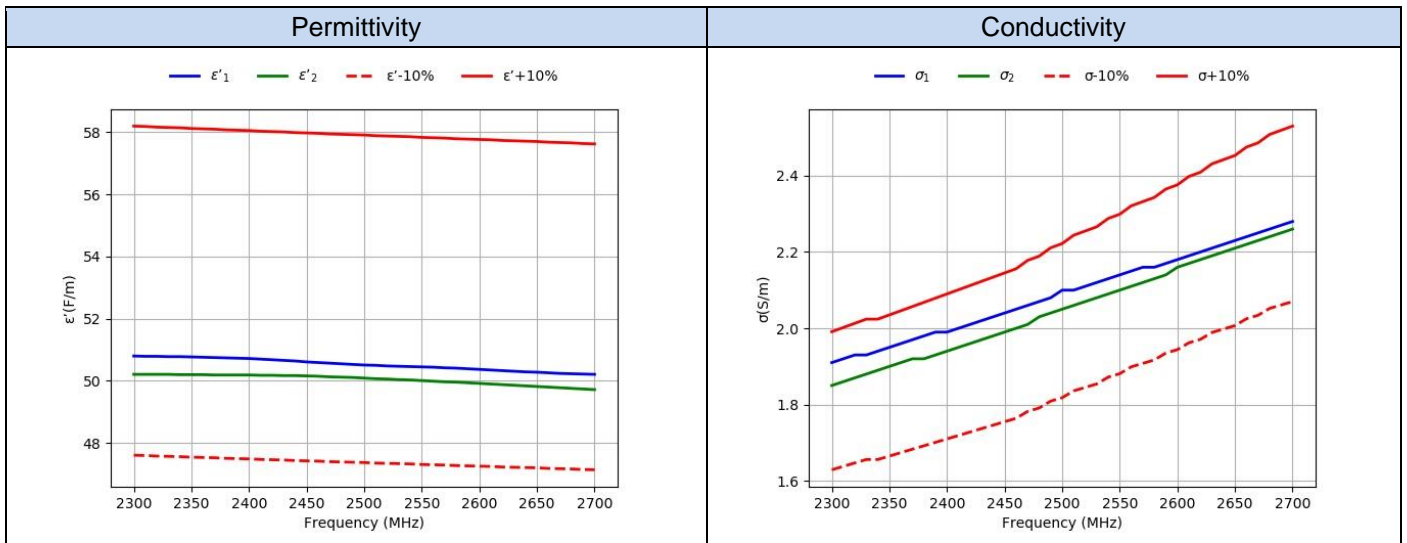

**D.7 Body 3500MHz-3900MHz**

			2022-01-24	
Target			Measured	
Freq.(MHz)	e' (F/m)	s (S/m)	e'1 (F/m)	s1 (S/m)
3500	51.32	3.31	48.11	3.04
3510	51.31	3.33	48.09	3.05
3520	51.29	3.34	48.07	3.06
3530	51.28	3.35	48.04	3.06
3540	51.27	3.36	48.02	3.07
3550	51.25	3.37	47.99	3.08
3560	51.24	3.38	47.97	3.09
3570	51.23	3.4	47.95	3.1
3580	51.21	3.41	47.92	3.12
3590	51.2	3.42	47.9	3.13
3600	51.19	3.43	47.89	3.14
3610	51.17	3.44	47.87	3.15
3620	51.16	3.45	47.86	3.16
3630	51.15	3.47	47.85	3.18
3640	51.13	3.48	47.84	3.19
3650	51.12	3.49	47.84	3.2
3660	51.1	3.5	47.83	3.22
3670	51.09	3.51	47.82	3.23
3680	51.08	3.52	47.8	3.24
3690	51.06	3.54	47.79	3.26
3700	51.05	3.55	47.78	3.27
3710	51.04	3.56	47.77	3.28
3720	51.02	3.57	47.76	3.29
3730	51.01	3.58	47.75	3.3
3740	51.0	3.59	47.74	3.31
3750	50.98	3.61	47.73	3.33
3760	50.97	3.62	47.73	3.34
3770	50.95	3.63	47.72	3.35
3780	50.94	3.64	47.71	3.36
3790	50.93	3.65	47.7	3.37
3800	50.91	3.66	47.69	3.38
3810	50.9	3.68	47.68	3.39
3820	50.89	3.69	47.66	3.41
3830	50.87	3.7	47.65	3.42
3840	50.86	3.71	47.63	3.43
3850	50.85	3.72	47.62	3.44
3860	50.83	3.73	47.61	3.45
3870	50.82	3.75	47.59	3.46
3880	50.81	3.76	47.58	3.48
3890	50.79	3.77	47.56	3.49
3900	50.78	3.78	47.55	3.5

