

TEST REPORT

EUT Description	Notebook PC
Brand Name	HP
Model Name	HSN-I46C
FCC/IC ID	FCC ID: B94HNI46CKLU; IC ID: 21374-FM350GL16
Date of Test Start/End	2023-11-02 / 2023-11-29
Features	WWAN (LTE, UMTS) (see section 5)

Applicant	HP
Address	1501 Page Mill Road, Palo Alto CA 94304 USA
Contact Person	Sam Lin
Telephone/Fax/ Email	(TEL) +886 2 37896331/sam.lin2@hp.com

Reference Standards	FCC CFR Title 47 Part 2, 22, 24, 27, 90, 96 RSS-Gen issue 5 A1, RSS 130 issue 2, RSS 132 issue 3, RSS 133 issue 6 A1, RSS 140 issue 1, RSS 139 issue 4, RSS-192 issue 4, RSS-195 issue 2, RSS 199 issue 3, RSS 197 issue 1 (see section 1)
---------------------	--

Test Report identification	231006-03.TR03
Revision Control	Rev. 01 This test report revision replaces any previous test report revision (see section 8)

The test results relate only to the samples tested.
 Reference to accreditation shall be used only by full reproduction of test report.

Issued by _____ Reviewed by _____

Khodor RIDA
 (Test Engineer Lead)

Zayd OUACHICHA
 (Technical Manager)

Table of Contents

- 1. Standards, reference documents and applicable test methods 3**
- 2. General conditions, competences and guarantees 3**
- 3. Environmental Conditions 4**
- 4. Test samples 5**
- 5. EUT Features 5**
- 6. Remarks and comments 6**
- 7. Test Verdicts summary 7**
- 8. Document Revision History 7**
- Annex A. Test & System Description 8**
 - A.1 MEASUREMENT SYSTEM..... 8
 - A.2 TEST EQUIPMENT LIST 10
 - A.2.1 *Radiated Setup*..... 10
 - A.3 MEASUREMENT UNCERTAINTY EVALUATION 11
- Annex B. Test Results 12**
 - B.1 RADIATED SPURIOUS EMISSION 12
 - B.1.1 *Standard references* 12
 - B.1.2 *Test procedure* 14
 - B.1.3 *Test Results*..... 15
 - B.1.3.1 WCDMA15
 - B.1.3.1 LTE.....16
 - B.1.3.2 UL carrier aggregation LTE (Intra-band).....22
 - B.2 DECLARED ERP / EIRP 24
- Annex C. Photographs 25**
 - C.1 RADIATED TEST SETUP 25
 - C.2 TEST SAMPLE 26

1. Standards, reference documents and applicable test methods

FCC	<ol style="list-style-type: none"> 1. FCC Title 47 CFR part 2 - Subpart J - Equipment Authorization Procedures. 2021-10-01 Edition 2. FCC Title 47 CFR part 22 - Subpart H - Cellular Radiotelephone Service. 2021-10-01 Edition 3. FCC Title 47 CFR part 24 – Subpart E - Broadband PCS. 2021-10-01 Edition 4. FCC Title 47 CFR part 27 – Subpart C - Technical Standards. 2021-10-01 Edition 5. FCC Title 47 CFR part 27 – Subpart L - 1695-1710, 1710-1755 MHz, 1755-1780 MHz, 2110-2155 MHz, 2155-2180 MHz, 2180-2200 MHz Bands. 2021-10-01 Edition 6. FCC Title 47 CFR Part 90 - Subpart R - Regulations governing the licensing and use of frequencies in the 763-775 and 793-805 MHz bands. 2021-10-01 Edition 7. FCC Title 47 CFR Part 90 - Subpart S - Regulations governing licensing and use of frequencies in the 806-824, 851-869, 896-901, and 935-940 MHz bands. 2021-10-01 Edition 8. FCC Title 47 CFR Part 96 - Subpart E - Technical rules. 2021-10-01 Edition 9. FCC OET KDB 971168 D01 v03r01 Measurement guidance for certification of licensed digital transmitters. 10. FCC OET KDB 842590 D01 v01r01 Upper Microwave Flexible Use Service. 11. C63.26-2015 - IEEE/ANSI Standard for Compliance Testing of Transmitters Used in Licensed Radio Services
ISED	<ol style="list-style-type: none"> 1. ISED RSS-Gen issue 5 A1 - General Requirements for Compliance of Radio Apparatus. 2. ISED RSS-130 issue 2 - Equipment Operating in the Frequency Bands 617-652 MHz, 663-698 MHz, 698-756 MHz and 777-787 MHz 3. ISED RSS 132 issue 3 - Cellular Telephone Systems Operating in the Bands 824-849 MHz and 869-894 MHz 4. ISED RSS 133 issue 6 A1 - 2 GHz Personal Communications Services. 5. ISED SRSP-510 — Technical Requirements for Personal Communications Services (PCS) in the Bands 1850-1915 MHz and 1930-1995 MHz 6. ISED RSS 139 issue 4 - Advanced Wireless Services Equipment Operating in the Bands 1710-1780 MHz and 2110-2200 MHz 7. ISED RSS-140 issue 1 - Equipment Operating in the Public Safety Broadband Frequency Bands 758-768 MHz and 788-798 MHz 8. ISED RSS-192 issue 4 - Flexible Use Broadband Equipment Operating in the Band 3450-3650 MHz 9. ISED RSS-195 issue 2 - Wireless Communication Service (WCS) Equipment Operating in the Bands 2305-2320 MHz and 2345-2360 MHz 10. ISED RSS-199 issue 3 - Broadband Radio Services (BRS) Equipment Operating in the Bands 2500-2690 MHz 11. ISED RSS-197 issue 1 - Wireless Broadband Access Equipment Operating in the Band 3650–3700 MHz 12. FCC OET KDB 971168 D01 v03r01 Measurement guidance for certification of licensed digital transmitters. 13. FCC OET KDB 842590 D01 v01r01 Upper Microwave Flexible Use Service. 14. C63.26-2015 - IEEE/ANSI Standard for Compliance Testing of Transmitters Used in Licensed Radio Services 15. C63.4-2014 – American National Standard for Methods of measurement of Radio-Noise Emissions from Low-Voltage Electrical and Electronic Equipment in the Range of 9kHz to 40GHz.

2. General conditions, competences and guarantees

- ✓ Tests performed under FCC standards identified in section 1 are covered by A2LA accreditation.
- ✓ Tests performed under ISED standards identified in section 1 are covered by Cofrac accreditation.
- ✓ Intel Corporation SAS Wireless RF Lab (Intel WRF Lab) is an ISO/IEC 17025:2017 laboratory accredited by the American Association for Laboratory Accreditation (A2LA) with the certificate number 3478.01.
- ✓ Intel Corporation SAS Wireless RF Lab (Intel WRF Lab) is an Accredited Test Firm recognized by the FCC, with Designation Number FR0011.
- ✓ Intel Corporation SAS Wireless RF Lab (Intel WRF Lab) is an ISO/IEC 17025:2017 testing laboratory accredited by the French Committee for Accreditation (Cofrac) with the certificate number 1-6736.
- ✓ Intel Corporation SAS Wireless RF Lab (Intel WRF Lab) is a Registered Test Site listed by ISED, with ISED #1000Y.
- ✓ Intel WRF Lab only provides testing services and is committed to providing reliable, unbiased test results and interpretations.
- ✓ Intel WRF Lab is liable to the client for the maintenance of the confidentiality of all information related to the item under test and the results of the test.
- ✓ Intel WRF Lab has developed calibration and proficiency programs for its measurement equipment to ensure correlated and reliable results to its customers.
- ✓ This report is only referred to the item that has undergone the test.
- ✓ This report does not imply an approval of the product by the Certification Bodies or competent Authorities.

3. Environmental Conditions

- ✓ At the site where the measurements were performed the following limits were not exceeded during the tests:

Temperature	24.6°C ± 0.5°C
Humidity	36.7% ± 10.4%

4. Test samples

Sample	Control #	Description	Model	Serial #	Date of receipt	Note
#01	231006-03.S02	Notebook PC	HSN-I46C	0003770981	2023/10/06	Vendor 1
#01	231006-03.S05	Notebook PC	HSN-I46C	003770980	2023/10/06	Vendor 2

5. EUT Features

The herein information is provided by the customer.

Intel WRF Lab declines any responsibility for the accuracy of the stated customer provided information, especially if it has any impact on the correctness of test results presented in this report.

Brand Name	HP							
Model Name	HSN-I46C							
Prototype / Production	/ Production							
Supported Radios	Mode	Bands	Supported Tx Mode					
			WCDMA	HSDPA	HSUPA	DC-HSDPA		
	WCDMA / HSPA+	FDD II (1850.0 – 1910.0 MHz)	✓	✓	✓	✓	✓	
		FDD IV (1710.0 – 1755.0 MHz)	✓	✓	✓	✓	✓	
		FDD V (824.0 – 849.0 MHz)	✓	✓	✓	✓	✓	
	Mode	Bands	Supported Channel Bandwidth (MHz)					
			1.4	3	5	10	15	20
	LTE FDD	Band 2 (1850.0 – 1910.0 MHz)	✓	✓	✓	✓	✓	✓
		Band 4 (1710.0 – 1755.0 MHz)	✓	✓	✓	✓	✓	✓
		Band 5 (824.0 – 849.0 MHz)	✓	✓	✓	✓		
		Band 7 (2500.0 – 2570.0 MHz)			✓	✓	✓	✓
		Band 12 (699.0 – 716.0 MHz)	✓	✓	✓	✓		
		Band 13 (777.0 – 787.0 MHz)			✓	✓		
		Band 14 (788.0 – 798.0 MHz)			✓	✓		
		Band 17 (704.0 – 716.0 MHz)			✓	✓		
		Band 25 (1850.0 – 1915.0 MHz)	✓	✓	✓	✓	✓	✓
		Band 26 (814.0 – 849.0 MHz)	✓	✓	✓	✓	✓	
		Band 30 (2305.0 – 2315.0 MHz)			✓	✓		
		Band 66 (1710.0 – 1780.0 MHz)	✓	✓	✓	✓	✓	✓
		Band 71 (663.0 – 698.0 MHz)			✓	✓	✓	✓
LTE TDD	Band 38 (2570.0 – 2620.0 MHz)			✓	✓	✓	✓	
	Band 41 (2496.0 – 2690.0 MHz)			✓	✓	✓	✓	
	Band 48 (3550.0 – 3700.0MHz)			✓	✓	✓	✓	
UL carrier aggregation LTE (Intra-band)								
Supported combinations								
FDD Band 5B								
FDD Band 7C								
FDD Band 66B								
FDD Band 66C								
TDD Band 38C								
TDD Band 41C								
Antenna Information	Transmitter	Ant 5			Ant 5			
	Manufacturer	Vendor 1			Vendor 2			
	Antenna type	PIFA antenna			PIFA antenna			
	Part number	6036B0312701 (81ELA215.G10)			6036B0313201 (0-3302700850)			
	Antenna peak gain (dBi)	1.98			0.05			

6. Remarks and comments

1. The DUT has two antenna manufacturers (Vendor 1 and Vendor 2) but the WWAN module and the rated output power remain the same. For each band, tests were performed on the highest peak antenna gain.
2. The tested configurations were selected based on the worst-case spurious emissions per frequency band from modular type approval report (FCC ID : B94HNI46CKLU, IC ID : 21374-FM350GL16)
3. In regard of RSS 197 annex C shows a description of the algorithm implementation for both reducing the EIRP the limit allowed and decoding an enabling signal from the base station before the mobile equipment can transmit

7. Test Verdicts summary

The statement of conformity to applicable standards in the table below are based on the measured values, without taking into account the measurement uncertainties.

RAT	Band	FCC part	RSS part	Verdict
WCDMA	WCDMA II	24.238, 2.1053	133-ch 6.5.1	P
	WCDMA IV	27.53 (h), 2.1053	139-ch.6.5	P
	WCDMA V	22.917(a), 2.1053	132-ch.5.5	P
LTE	LTE 2	24.238(a), 2.1053	133-ch 6.5.1	NM
	LTE 4	27.53 (h), 2.1053	139-ch.6.5	NM
	LTE 5	22.917(a), 2.1053	132-ch.5.5	NM
	LTE 7	27.53 (m)(4), 2.1053	199-ch.4.5	P
	LTE12	27.53 (g), 2.1053	130-ch.4.7	P
	LTE 13	27.53 (c)(f), 2.1053	130-ch.4.7	P
	LTE14	90.543(e)(f), 2.1053	140-ch.4.4	P
	LTE17	27.53 (g), 2.1053	130-ch.4.7	NM
	LTE 25	24.238(a), 2.1053	133-ch 6.5.1	P
	LTE 26	90.691, 22.917(a), 2.1053	132-ch.5.5	P
	LTE 30	27.53 (a)(4), 2.1053	195- ch.5.6.2	P
	LTE 38	27.53 (m)(4), 2.1053	199-ch.4.5	NM
	LTE 41	27.53 (m)(4), 2.1053	199-ch.4.5	P
	LTE 48	96.41(e), 2.1053	192-ch.8.7, 197-ch.5.7	P
	LTE 66	27.53(h), 2.1053	139-ch.6.5	P
LTE 71	27.53(m)(4), 2.1053	130-ch.4.7	P	
LTE ULCA	5B_CA	22.917(a), 2.1053	132-ch.5.5	P
	7C_CA	27.53 (m)(4), 2.1053	199-ch.4.5	P
	66B_CA	27.53(h), 2.1053	139-ch.6.5	P
	38C_CA	27.53 (m)(4), 2.1053	199-ch.4.5	NM
	41C_CA	27.53 (m)(4), 2.1053	199-ch.4.5	P

* Rx Spurious emission not measured for RSS Parts 132, 133 and 197

P: Pass
 F: Fail
 NM: Not Measured
 NA: Not Applicable

8. Document Revision History

Revision #	Modified by	Revision Details
Rev. 00	R.SIMONINI	First Issue
Rev. 01	R.SIMONINI	Correction of the EUT model name and update of the Antenna part number. Correction of the Cal due date for the cable 007-023.

Annex A. Test & System Description

A.1 Measurement System

Measurements were performed using the following setups. A communication tester was used to establish a communication link with the EUT, and the communication tester parameters were set to get the maximum output power from the EUT.

Radiated test setup

Radiated Setup 30 MHz - 1 GHz (Transmitter tests)

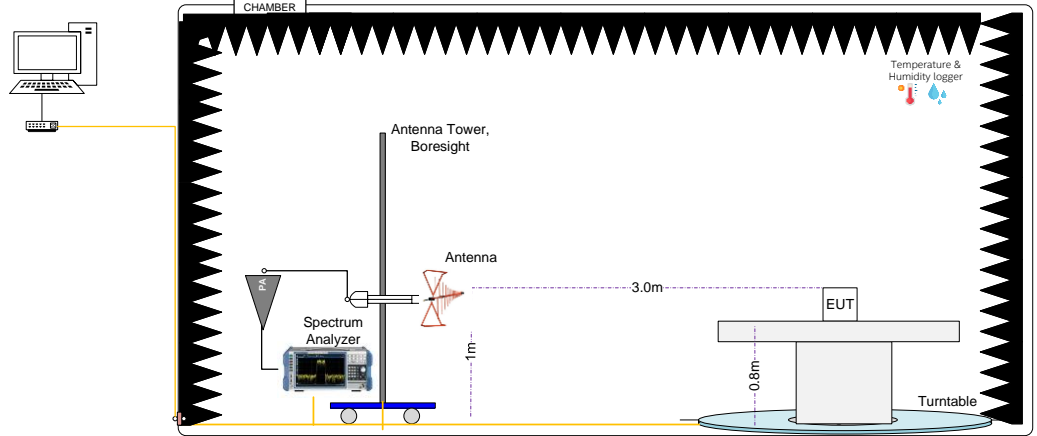

Radiated Setup 1 GHz – 6.4 GHz (Transmitter tests)

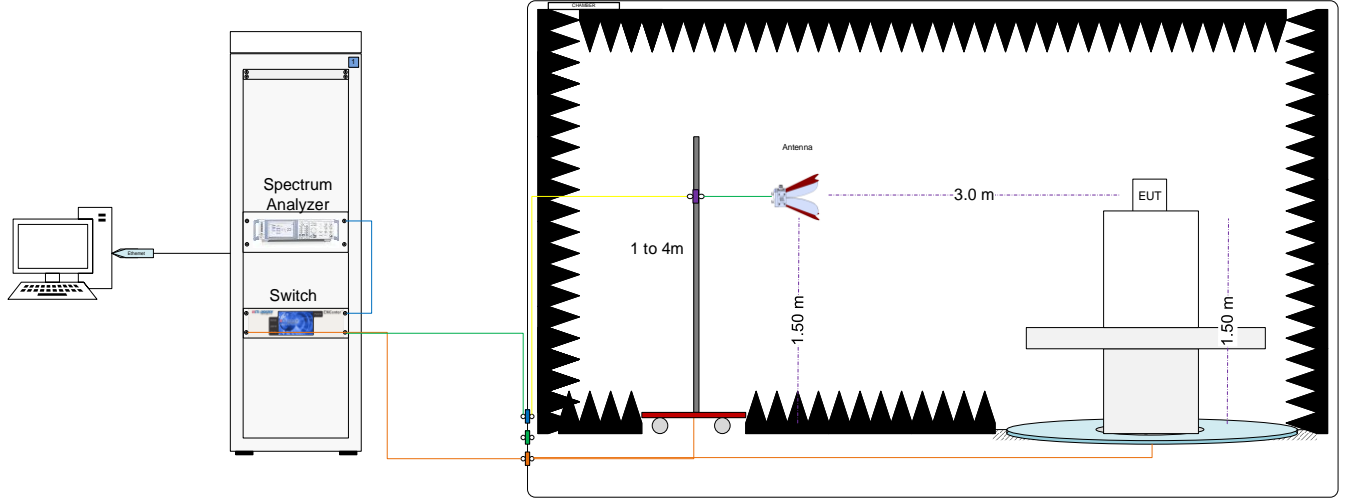

Radiated Setup 6.4 GHz – 18 GHz (Transmitter tests)

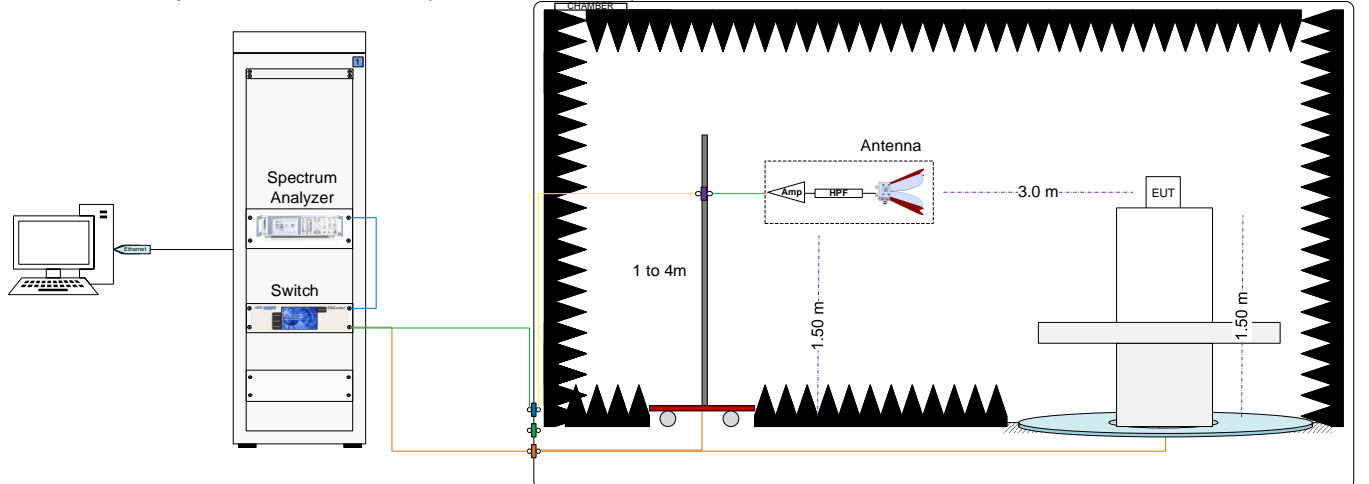

Radiated Setup 10 GHz – 40GHz (Transmitter tests)

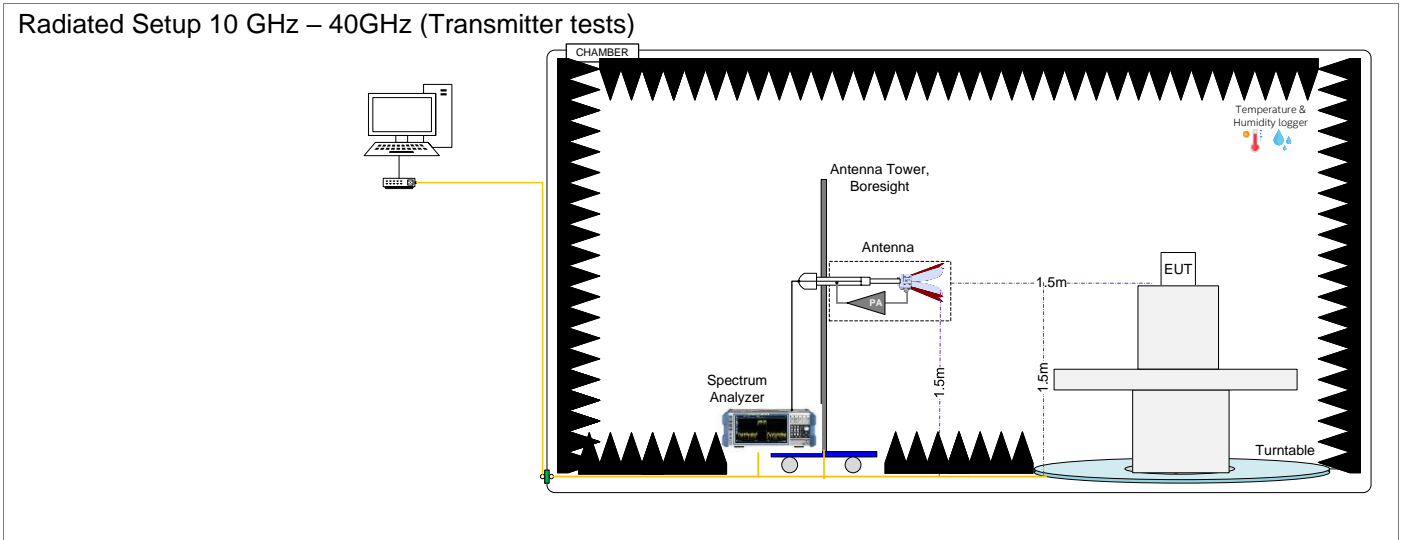

Sample Calculation

The spurious received power P at the spectrum Analyzer is converted to EIRP the equivalent isotropically radiated power, in dBm using the transducer factor F corresponding to the Rx path Loss:

$$F \text{ (dB)} = \text{Free Space Attenuation (dB)} + \text{Cable losses (dB)} - \text{Amplifiers Gain (dB)} - \text{Rx Antenna Gain (dBi)}$$

$$\text{EIRP (dBm)} = P(\text{dBm}) + F \text{ (dB)}$$

$$\text{ERP (dBm)} = \text{EIRP} - 2.15$$

A.2 Test Equipment List

A.2.1 Radiated Setup

Radiated Setup #1

ID#	Device	Type/Model	Serial #	Manufacturer	Cal. Date	Cal. Due Date
006-000	Anechoic chamber	FACT 3	5720	ETS Lindgren	2022-01-21	2024-01-21
006-001	Turntable	-	-	ETS Lindgren	NA	NA
006-008	Measurement Software V11.30.00	EMC32	100623	Rohde & Schwarz	N/A	N/A
147-000	Spectrum analyzer	FSW43	101847	Rohde & Schwarz	2022-11-30	2024-11-30
006-002	Switch & Positioning	EMC center	00159757	ETS Lindgren	N/A	N/A
006-011	Boresight antenna mast	BAM4.0-P	P/278/2890.01	Maturo	N/A	N/A
006-061	Bi-Log Periodic antenna	CBL6143A	61382	Teseq	2022-10-24	2024-10-24
057-000	Double Horn Ridged antenna	3117	167062	ETS-Lindgren	2022-07-08	2024-07-08
058-000	Double Horn Ridged antenna	3116C	157511	ETS-Lindgren	2022-10-21	2024-10-21
007-008	Double Horn Ridged antenna	3116C-PA	00169308bis + 00196308	ETS-Lindgren	2023-05-30	2025-05-30
006-023	Conical log spiral antenna	3102	00154400	ETS Lindgren	NA	NA
007-030	Horn Antenna 1-18GHz	3115	9911-5967	Emco	NA	NA
301-000	Amplifier 9kHz-1300MHz	8447F	3113A07440	HP	2023-03-03	2024-03-03
261-000	Amplifier 1GHz-18GHz	3117-PA	00157993	ETS-Lindgren	2023-02-20	2024-02-20
006-067	Low Pass Filter 1.6GHz	LPM17671	G002	Micro-Tronics	2023-08-18	2024-08-18
006-068	RF Switch	RC-2SP6T-40	02112090061	Micro-Circuits	2023-08-22	2024-08-22
006-063	Cable 30cm	PE371-12	-	Pasternack	2023-02-27	2024-02-27
006-064	Cable 30cm	PE371-12	-	Pasternack	2023-02-27	2024-02-27
006-065	Cable 60cm	PE300-24	-	Pasternack	2023-06-02	2024-06-02
006-066	Cable 7m	R286304174	20.46.370	Radiall	2023-08-16	2024-08-16
259-000	Temp & Humidity Logger	RA12E-TH-RAS	RA12-B9BD70	Avtech	2022-06-27	2024-06-27
490-000	Communication tester	CMX500	1201.0002K70	Rohde & Schwarz	N/A	N/A

N/A: Not Applicable

Radiated Setup #2

ID#	Device	Type/Model	Serial #	Manufacturer	Cal. Date	Cal. Due Date
007-000	Anechoic chamber*	RFD-FA-100	5996	ETS Lindgren	2021-09-14	2024-03-14
007-002	Turntable	-	-	ETS Lindgren	N/A	N/A
007-003	Antenna Tower	2171B-3.0M	00150123	ETS Lindgren	N/A	N/A
007-006	Switch & Positioner	EMCenter	00151232	ETS Lindgren	N/A	N/A
007-005	Measurement SW, V11.20.00	EMC32	100401	Rohde & Schwarz	N/A	N/A
127-000	Spectrum Analyzer	FSV40	101358	Rohde & Schwarz	2023-01-27	2025-01-27
006-023	Conical log spiral antenna	3102	00154400	ETS Lindgren	NA	NA
007-030	Horn Antenna 1-18GHz	3115	9911-5967	Emco	NA	NA
007-007	Double Ridge Horn (1- 18GHz)	3117	00152266	ETS Lindgren	2022-03-29	2024-03-29
007-008	Double Horn Ridged antenna	3116C-PA	00169308bis + 00196308	ETS-Lindgren	2023-05-30	2025-05-30
007-022	RF Cable 1-18GHz, 1.5m	0501050991200GX	19.23.493	Radiall	2023-02-13	2024-02-13
007-020	RF Cable 1-18GHz, 1.2 m	2301761761200PJ	12.22.1104	Radiall	2023-02-15	2024-02-15
007-011	RF Cable 1-18GHz – 6.5m	140-8500-11-51	001	Atem	2023-02-15	2024-02-15
007-015	RF Cable 1GHz-18GHz 1.5m	-	-	Spirent	2023-02-13	2024-02-13
007-014	RF Cable 18-40 GHz 6m	R286304009	1747364	Radiall	2023-02-16	2024-02-16
007-023	RF Cable 1m DC-40GHz	PE360-100CM	-	Pasternack	2023-02-14	2024-02-14
007-018	RF Cable 1-9.5GHz 1.2m	0500990991200KE	-	Radiall	2023-02-13	2024-02-13
325-000	Temp & Humidity Logger	RA12E-TH1-RAS	RA12-B9B7C6	Avtech	2022-01-17	2024-01-17
490-000	Communication tester	CMX500	1201.0002K70	Rohde & Schwarz	N/A	N/A

N/A: Not Applicable

A.3 Measurement Uncertainty Evaluation

The system uncertainty evaluation is shown in the table below with a coverage factor of $k = 2$ to indicate a 95% level of confidence:

Measurement type	Uncertainty	Unit
Tx Radiated test < 1GHz	± 6.40	dB
Tx Radiated test 1GHz - 40 GHz	± 6.04	dB
Rx Radiated test < 1GHz	± 6.29	dB
Rx Radiated test 1GHz - 40 GHz	± 6.40	dB

Annex B. Test Results

The herein test results were performed by:

Test case measurement	Test Personnel
Tx spurious emissions	R.SIMONINI
Rx spurious emissions	R.SIMONINI

B.1 Radiated spurious emission

B.1.1 Standard references

Band	FCC part	RSS Part	FCC Limit	IC Limit
WCDMA II LTE 2 LTE 25	24.238, 2.1053	133-ch 6.5.1	The power of any emission outside of the authorized operating frequency ranges must be attenuated below the transmitting power (P) by a factor of at least $43 + 10 \log(P)$ dB	(ii) After the first 1.0 MHz, the emission power in any 1 MHz bandwidth shall be attenuated (in dB) below the transmitter output power P (dBW) by at least $43 + 10 \log_{10} p$ (watts). If the measurement is performed using 1% of the emission bandwidth, power integration over 1 MHz is required.
WCDMA IV LTE 4 LTE 66	27.53 (h), 2.1053	139-ch.5.6	The power of any emission outside of the authorized operating frequency ranges must be attenuated below the transmitting power (P) by a factor of at least $43 + 10 \log(P)$ dB	(ii) After the first 1.0 MHz outside the equipment's smallest operating frequency block, which can contain the equipment's occupied bandwidth, the emission power in any 1 MHz bandwidth shall be attenuated below the transmitter output power P (in dBW) by at least $43 + 10 \log_{10} p$ (watts) dB.
WCDMA V LTE 5 LTE 26	22.917, 2.1053 90.691, 22.917, 2.1053	132-ch.5.5	The power of any emission outside of the authorized operating frequency ranges must be attenuated below the transmitting power (P) by a factor of at least $43 + 10 \log(P)$ dB	(ii) After the first 1.0 MHz immediately outside and adjacent to each of the sub-bands, the power of emissions in any 100 kHz bandwidth shall be attenuated (in dB) below the transmitter output power P (dBW) by at least $43 + 10 \log_{10} p$ (watts). If the measurement is performed using 1% of the occupied bandwidth, power integration over 100 kHz is required.
LTE 12 LTE 13 LTE 17 LTE 71	27.53 (g)(f), 2.1053	130-ch.4.7	The power of any emission outside a licensee's frequency block shall be attenuated below the transmitting power (P) by a factor of at least $43 + 10 \log(P)$ dB. For operations in the 746-758 MHz, 775-788 MHz, and 805-806 MHz bands, emissions in the band 1559-1610 MHz shall be limited to -70 dBW/MHz equivalent isotropically radiated power (EIRP) for wideband signals, and -80 dBW EIRP for discrete emissions of less than 700 Hz bandwidth.	The power of any emission outside a licensee's frequency block shall be attenuated below the transmitting power (P) by a factor of at least $43 + 10 \log(P)$ dB. In addition, equipment operating in the frequency bands 746-756 MHz and 777-787 MHz shall also comply with the following restrictions: a) The power of any unwanted emissions in any 6.25 kHz bandwidth for all frequencies between 763-775 MHz and 793-806 MHz shall be attenuated below the transmitter power, P (dBW), by at least: (i) $76 + 10 \log_{10} p$ (watts), dB, for base and fixed equipment, and (ii) $65 + 10 \log_{10} p$ (watts), dB, for mobile and portable equipment. b) The e.i.r.p. in the band 1559-1610 MHz shall not exceed -70 dBW/MHz for wideband signal and -80 dBW for discrete emission with bandwidth less than 700 Hz.

Band	FCC part	RSS Part	FCC Limit	IC Limit																																		
LTE 14	90.543(c)	140-ch4.4	<p>(e) For operations in the 758-768 MHz and the 788-798 MHz bands, the power of any emission outside the licensee's frequency band(s) of operation shall be attenuated below the transmitter power (P) within the licensed band(s) of operation, measured in watts, in accordance with the following:</p> <p>(1) On all frequencies between 769-775 MHz and 799-805 MHz, by a factor not less than $76 + 10 \log(P)$ dB in a 6.25 kHz band segment, for base and fixed stations.</p> <p>(2) On all frequencies between 769-775 MHz and 799-805 MHz, by a factor not less than $65 + 10 \log(P)$ dB in a 6.25 kHz band segment, for mobile and portable stations.</p> <p>(3) On any frequency between 775-788 MHz, above 805 MHz, and below 758 MHz, by at least $43 + 10 \log(P)$ dB.</p> <p>(4) Compliance with the provisions of paragraphs (e)(1) and (2) of this section is based on the use of measurement instrumentation such that the reading taken with any resolution bandwidth setting should be adjusted to indicate spectral energy in a 6.25 kHz segment.</p> <p>(5) Compliance with the provisions of paragraph (e)(3) of this section is based on the use of measurement instrumentation employing a resolution bandwidth of 100 kHz or greater. However, in the 100 kHz bands immediately outside and adjacent to the frequency block, a resolution bandwidth of 30 kHz may be employed.</p>	<p>The power of any unwanted emission outside the bands 758-768 MHz and 788-798 MHz shall be attenuated below the transmitter output power P in dBW as follows, where p is the transmitter output power in watts:</p> <p>For any frequency between 769-775 MHz and 799-806 MHz:</p> <ul style="list-style-type: none"> $76 + 10 \log(p)$, dB in a 6.25 kHz band for fixed and base station equipment $65 + 10 \log(p)$, dB in a 6.25 kHz band for mobile and portable/hand-held equipment <p>For any frequency between 775-788 MHz, above 806 MHz, and below 758 MHz: $43 + 10 \log(p)$, dB in a bandwidth of 100 kHz or greater. However, in the 100 kHz bands immediately outside and adjacent to the frequency bands 758-768 MHz and 788-798 MHz, a resolution bandwidth of 30 kHz may be employed.</p> <p>In addition, the equivalent isotropically radiated power (e.i.r.p.) of all emissions, including harmonics in the band 1559-1610 MHz, shall not exceed -70 dBW/MHz for wideband emissions, and -80 dBW/kHz for discrete emissions of less than 700 Hz bandwidth.</p>																																		
LTE 30	27.53 (a)(4), 2.1053	195 ch.5.6.2	<p>By a factor of not less than: $43 + 10 \log(P)$ dB on all frequencies between 2305 and 2320 MHz and on all frequencies between 2345 and 2360 MHz that are outside the licensed band(s) of operation, not less than $55 + 10 \log(P)$ dB on all frequencies between 2320 and 2324 MHz and on all frequencies between 2341 and 2345 MHz, not less than $61 + 10 \log(P)$ dB on all frequencies between 2324 and 2328 MHz and on all frequencies between 2337 and 2341 MHz, and not less than $67 + 10 \log(P)$ dB on all frequencies between 2328 and 2337 MHz;</p> <p>(ii) By a factor of not less than $43 + 10 \log(P)$ dB on all frequencies between 2300 and 2305 MHz, $55 + 10 \log(P)$ dB on all frequencies between 2296 and 2300 MHz, $61 + 10 \log(P)$ dB on all frequencies between 2292 and 2296 MHz, $67 + 10 \log(P)$ dB on all frequencies between 2288 and 2292 MHz, and $70 + 10 \log(P)$ dB below 2288 MHz;</p> <p>(iii) By a factor of not less than $43 + 10 \log(P)$ dB on all frequencies between 2360 and 2365 MHz, and not less than $70 + 10 \log(P)$ dB above 2365 MHz.</p>	<table border="1"> <thead> <tr> <th>Frequency (MHz)</th> <th>Attenuation (dB)</th> </tr> </thead> <tbody> <tr> <td><2200</td> <td>$43 + 10 \log_{10}(p)$</td> </tr> <tr> <td>2200 - 2288</td> <td>$70 + 10 \log_{10}(p)$</td> </tr> <tr> <td>2288 - 2292</td> <td>$67 + 10 \log_{10}(p)$</td> </tr> <tr> <td>2292 - 2296</td> <td>$61 + 10 \log_{10}(p)$</td> </tr> <tr> <td>2296 - 2300</td> <td>$55 + 10 \log_{10}(p)$</td> </tr> <tr> <td>2300 - 2305</td> <td>$43 + 10 \log_{10}(p)$</td> </tr> <tr> <td>2305 - 2320</td> <td>$43 + 10 \log_{10}(p)$</td> </tr> <tr> <td>2320 - 2324</td> <td>$55 + 10 \log_{10}(p)$</td> </tr> <tr> <td>2324 - 2328</td> <td>$61 + 10 \log_{10}(p)$</td> </tr> <tr> <td>2328 - 2337</td> <td>$67 + 10 \log_{10}(p)$</td> </tr> <tr> <td>2337 - 2341</td> <td>$61 + 10 \log_{10}(p)$</td> </tr> <tr> <td>2341 - 2345</td> <td>$55 + 10 \log_{10}(p)$</td> </tr> <tr> <td>2345 - 2360</td> <td>$43 + 10 \log_{10}(p)$</td> </tr> <tr> <td>2360 - 2365</td> <td>$43 + 10 \log_{10}(p)$</td> </tr> <tr> <td>2365 - 2395</td> <td>$70 + 10 \log_{10}(p)$</td> </tr> <tr> <td>>2395</td> <td>$43 + 10 \log_{10}(p)$</td> </tr> </tbody> </table>	Frequency (MHz)	Attenuation (dB)	<2200	$43 + 10 \log_{10}(p)$	2200 - 2288	$70 + 10 \log_{10}(p)$	2288 - 2292	$67 + 10 \log_{10}(p)$	2292 - 2296	$61 + 10 \log_{10}(p)$	2296 - 2300	$55 + 10 \log_{10}(p)$	2300 - 2305	$43 + 10 \log_{10}(p)$	2305 - 2320	$43 + 10 \log_{10}(p)$	2320 - 2324	$55 + 10 \log_{10}(p)$	2324 - 2328	$61 + 10 \log_{10}(p)$	2328 - 2337	$67 + 10 \log_{10}(p)$	2337 - 2341	$61 + 10 \log_{10}(p)$	2341 - 2345	$55 + 10 \log_{10}(p)$	2345 - 2360	$43 + 10 \log_{10}(p)$	2360 - 2365	$43 + 10 \log_{10}(p)$	2365 - 2395	$70 + 10 \log_{10}(p)$	>2395	$43 + 10 \log_{10}(p)$
Frequency (MHz)	Attenuation (dB)																																					
<2200	$43 + 10 \log_{10}(p)$																																					
2200 - 2288	$70 + 10 \log_{10}(p)$																																					
2288 - 2292	$67 + 10 \log_{10}(p)$																																					
2292 - 2296	$61 + 10 \log_{10}(p)$																																					
2296 - 2300	$55 + 10 \log_{10}(p)$																																					
2300 - 2305	$43 + 10 \log_{10}(p)$																																					
2305 - 2320	$43 + 10 \log_{10}(p)$																																					
2320 - 2324	$55 + 10 \log_{10}(p)$																																					
2324 - 2328	$61 + 10 \log_{10}(p)$																																					
2328 - 2337	$67 + 10 \log_{10}(p)$																																					
2337 - 2341	$61 + 10 \log_{10}(p)$																																					
2341 - 2345	$55 + 10 \log_{10}(p)$																																					
2345 - 2360	$43 + 10 \log_{10}(p)$																																					
2360 - 2365	$43 + 10 \log_{10}(p)$																																					
2365 - 2395	$70 + 10 \log_{10}(p)$																																					
>2395	$43 + 10 \log_{10}(p)$																																					
LTE 7 LTE 38 LTE 41	27.53 (m), 2.1053	199-ch.4.5	<p>For mobile digital stations, the attenuation factor shall be not less than $40 + 10 \log(P)$ dB on all frequencies between the channel edge and 5 megahertz from the channel edge, $43 + 10 \log(P)$ dB on all frequencies between 5 megahertz and X megahertz from the channel edge, and $55 + 10 \log(P)$ dB on all frequencies more than X megahertz from the channel edge, where X is the greater of 6 megahertz or the actual emission bandwidth as defined in paragraph (m)(6) of this section. In addition, the attenuation factor shall not be less than $43 + 10 \log(P)$ dB on all frequencies between 2490.5 MHz and 2496 MHz and $55 + 10 \log(P)$ dB at or below 2490.5 MHz.</p>	<p>for mobile subscriber equipment, the power of any unwanted emissions measured as above shall be attenuated (in dB) below the transmitter power, P (dBW), by at least:</p> <p>(i) $40 + 10 \log_{10} p$ from the channel edges to 5 MHz away</p> <p>(ii) $43 + 10 \log_{10} p$ between 5 MHz and X MHz from the channel edges, and</p> <p>(iii) $55 + 10 \log_{10} p$ at X MHz and beyond from the channel edges</p> <p>In addition, the attenuation shall not be less than $43 + 10 \log_{10} p$ on all frequencies between 2490.5 MHz and 2496 MHz, and $55 + 10 \log_{10} p$ at or below 2490.5 MHz.</p>																																		

Band	FCC part	RSS Part	FCC Limit	IC Limit																			
LTE 48 LTE 42	96.41(e)		<p>(ii) Except as otherwise specified in paragraph (e)(2) of this section, for channel and frequency assignments made by a CBSD to End User Devices, the conducted power of any End User Device emission outside the fundamental emission (whether in or outside of the authorized band) shall not exceed -13 dBm/MHz within 0 to B megahertz (where B is the bandwidth in megahertz of the assigned channel or multiple contiguous channels of the End User Device) above the upper CBSD-assigned channel edge and within 0 to B megahertz below the lower CBSD-assigned channel edge. At all frequencies greater than B megahertz above the upper CBSD assigned channel edge and less than B megahertz below the lower CBSD-assigned channel edge, the conducted power of any End User Device emission shall not exceed -25 dBm/MHz. Notwithstanding the emission limits in this paragraph, the Adjacent Channel Leakage Ratio for End User Devices shall be at least 30 dB.</p> <p>(2) Additional protection levels. Notwithstanding paragraph (e)(1) of this section, for CBSDs and End User Devices, the conducted power of emissions below 3540 MHz or above 3710 MHz shall not exceed -25 dBm/MHz, and the conducted power of emissions below 3530 MHz or above 3720 MHz shall not exceed -40dBm/MHz</p>																				
LTE48		192- ch.8.7	-	<p>Subscriber equipment shall have the TRP (per cell) or conducted power (per single antenna connector), where applicable, of unwanted emission outside the frequency block group not exceeding the following, where B is the frequency block group in MHz as shown in table 5.</p> <table border="1"> <thead> <tr> <th rowspan="2">Frequency block group (B)</th> <th colspan="4">Offset frequency from the edge of the frequency block group (MHz)</th> </tr> <tr> <th>0-1</th> <th>1-5</th> <th>5-B</th> <th>>B</th> </tr> </thead> <tbody> <tr> <td>10 MHz, 20MHz, 30 MHz and 40 MHz</td> <td>-13dBm/1% of B</td> <td>-10 dBm/MHz</td> <td>-13 dBm/MHz</td> <td>-25 dBm/MHz</td> </tr> <tr> <td>> 40 MHz</td> <td>-24 dBm/30 kHz</td> <td>-10 dBm/MHz</td> <td>-13 dBm/MHz</td> <td>-25 dBm/MHz</td> </tr> </tbody> </table> <p>Notwithstanding the above limits in 8.7.2 and 8.7.3, the TRP (per cell) or conducted power (per single antenna connector), where applicable, for the unwanted emissions shall not exceed: for subscriber equipment: -30 dBm/MHz in the frequency range greater than (B+5) MHz from the edge of the frequency band, where B is the frequency block group in MHz</p>	Frequency block group (B)	Offset frequency from the edge of the frequency block group (MHz)				0-1	1-5	5-B	>B	10 MHz, 20MHz, 30 MHz and 40 MHz	-13dBm/1% of B	-10 dBm/MHz	-13 dBm/MHz	-25 dBm/MHz	> 40 MHz	-24 dBm/30 kHz	-10 dBm/MHz	-13 dBm/MHz	-25 dBm/MHz
Frequency block group (B)	Offset frequency from the edge of the frequency block group (MHz)																						
	0-1	1-5	5-B	>B																			
10 MHz, 20MHz, 30 MHz and 40 MHz	-13dBm/1% of B	-10 dBm/MHz	-13 dBm/MHz	-25 dBm/MHz																			
> 40 MHz	-24 dBm/30 kHz	-10 dBm/MHz	-13 dBm/MHz	-25 dBm/MHz																			
LTE 48		197- ch.5.7	-	<p>The unwanted emissions shall be measured at the frequencies of the highest and lowest channel of all bandwidths and types of modulation that the equipment can operate with a resolution bandwidth of 1 MHz or less, but at least 1% of the occupied bandwidth of the transmitter, provided that the measured power is integrated over a 1 MHz bandwidth.</p> <p>The power of any emissions outside the frequency band 3650-3700 MHz shall be attenuated below the channel transmitter power P (dBW) by $43 + 10 \text{ Log } (p)$, where p is measured in watts</p>																			

B.1.2 Test procedure

The setup described in Test & System Description section was used to measure the radiated spurious emissions. Depending on the frequency range and bands being tested, different antennas and filters were used. The final measurement is done by varying the antenna height from 1 to 4 meters, the EUT azimuth over 360° and for both Vertical and Horizontal polarizations.

B.1.3 Test Results

B.1.3.1 WCDMA

WCDMA 2 – Antenna Vendor 1

30 MHz to 26.5 GHz - Radiated Spurious WCDMA 2- QPSK - Mid channel – 1880 MHz				
Frequency	RMS (EIRP)	Limit	Margin	Correction Factor
MHz	dBm	dBm	dB	dB
153.8	-55.4	-13.0	42.4	-100.1
1235.0	-46.8	-13.0	33.8	-63.2
2567.5	-41.9	-13.0	28.9	-59.5
2975.5	-41.4	-13.0	28.4	-59.1
9428.5	-47.8	-13.0	34.8	-86.2
18567.6	-57.8	-13.0	44.8	-88.8

WCDMA 4 – Antenna Vendor 1

30 MHz to 18GHz - Radiated Spurious WCDMA 4- QPSK - Mid channel – 1732.5 MHz				
Frequency	RMS (EIRP)	Limit	Margin	Correction Factor
MHz	dBm	dBm	dB	dB
153.8	-55.4	-13.0	42.4	-100.1
1223.0	-47.1	-13.0	34.1	-63.4
2383.5	-42.5	-13.0	29.5	-59.9
2885.5	-41.4	-13.0	28.4	-59.1
9935.5	-47.3	-13.0	34.3	-85.7
16000.0	-58.4	-13.0	45.4	-91.2

WCDMA 5 – Antenna Vendor 1

30 MHz to 10 GHz - Radiated Spurious WCDMA 5- QPSK - Mid channel – 836.5 MHz				
Frequency	RMS (ERP)	Limit	Margin	Correction Factor
MHz	dBm	dBm	dB	dB
246.1	-34.1	-13.0	19.0	-71.9
1214.0	-53.7	-13.0	38.6	-102.0
1937.5	-54.3	-13.0	39.2	-97.8
2475.5	-50.1	-13.0	35.0	-95.2
4982.0	-54.4	-13.0	39.3	-90.9
7964.5	-51.1	-13.0	36.0	-87.9

B.1.3.1 LTE

LTE 7 – Antenna Vendor 1

30MHz to 26.5GHz - Radiated Spurious LTE 7- QPSK – Low channel – 2510 MHz BW 20 MHz				
Frequency	RMS (EIRP)	Limit	Margin	Correction Factor
MHz	dBm	dBm	dB	dB
153.8	-55.3	-25.0	30.3	-100.1
1217.0	-46.3	-25.0	21.3	-63.5
2206.5	-42.4	-25.0	17.4	-60.7
2961.5	-41.3	-25.0	16.3	-59.1
9516.0	-48.5	-25.0	23.5	-85.9
24439.2	-54.4	-25.0	29.4	-82.7

LTE 12 – Antenna Vendor 1

30MHz to 10GHz - Radiated Spurious LTE 12 - QPSK - Mid channel – 707.5 MHz BW 10 MHz				
Frequency	RMS (ERP)	Limit	Margin	Correction Factor
MHz	dBm	dBm	dB	dB
437.5	-33.8	-13.0	18.7	-67.9
2098.5	-45.7	-13.0	30.6	-97.2
2206.5	-49.2	-13.0	34.1	-97.0
2657.5	-52.9	-13.0	37.8	-94.2
4981.5	-54.4	-13.0	39.3	-91.0
6757.0	-53	-13.0	37.9	-88.9

LTE 13 – Antenna Vendor 1

30MHz to 10GHz - Radiated Spurious LTE 13 - QPSK - High channel – 784.5 MHz BW 5 MHz				
Frequency	RMS (ERP)	Limit	Margin	Correction Factor
MHz	dBm	dBm	dB	dB
312.5	-36.3	-13.0	21.2	-70.2
1591.5	-59.3	-40,0	17.2	-102.9
2347.0	-30.6	-13.0	15.5	-96.2
2651.0	-52.8	-13.0	37.7	-93.9
3652.0	-54.5	-13.0	39.4	-92.9
7200.0	-51	-13.0	35.9	-88.1

LTE 14 – Antenna Vendor 1

30MHz to 9.5GHz - Radiated Spurious LTE 14 - QPSK - Mid channel – 793 MHz BW 5 MHz				
Frequency	RMS (ERP)	Limit	Margin	Correction Factor
MHz	dBm	dBm	dB	dB
312.5	-37.1	-13.0	22.0	-70.2
1581.5	-55.7	-40.0	13.6	-102.9
2217.5	-49.2	-13.0	34.1	-96.9
2372.5	-32.9	-13.0	17.8	-95.9
3954.0	-54.1	-13.0	39.0	-92.4
7246.5	-50.9	-13.0	35.8	-88.3

LTE 25 – Antenna Vendor 1

30MHz to 26.5GHz - Radiated Spurious LTE 25 - QPSK - High channel – 1905 MHz BW 20 MHz				
Frequency	RMS (EIRP)	Limit	Margin	Correction Factor
MHz	dBm	dBm	dB	dB
44.9	-59.9	-13.0	46.9	-96.8
1217.5	-46.4	-13.0	33.4	-63.5
2529.5	-41.4	-13.0	28.4	-59.4
2908.0	-41.4	-13.0	28.4	-59.1
9396.5	-48.3	-13.0	35.3	-86.3
18559.7	-58.0	-13.0	45.0	-89.0

LTE 26 – Antenna Vendor 1

30MHz to 9.5GHz - Radiated Spurious LTE 26 - QPSK - Mid channel – 831.5 MHz BW 15 MHz				
Frequency	RMS (ERP)	Limit	Margin	Correction Factor
MHz	dBm	dBm	dB	dB
39.2	-30	-13.0	14.9	-66.4
1649.5	-52.9	-13.0	37.8	-102.2
2214.0	-49.2	-13.0	34.1	-97.0
2474.5	-31.9	-13.0	16.8	-95.2
4124.0	-49.7	-13.0	34.6	-91.4
7189.0	-50.8	-13.0	35.6	-88.2

LTE 30 – Antenna Vendor 1

30MHz to 26.5GHz - Radiated Spurious LTE 30 - QPSK - Mid channel – 2310 MHz BW 10 MHz				
Frequency	RMS (EIRP)	Limit	Margin	Correction Factor
MHz	dBm	dBm	dB	dB
153.8	-55.4	-40.0	15.4	-100.1
3301.5	-45.7	-40.0	5.7	-76.5
3894.5	-55.2	-40.0	15.2	-84.4
5227.5	-52.0	-40.0	12.0	-81.7
7535.1	-50.5	-40.0	10.5	-78.4
22423.3	-55.5	-40.0	15.5	-82.9

LTE 41 – Antenna Vendor 1

30MHz to 26.5GHz - Radiated Spurious LTE 41 - QPSK - Low channel – 2506 MHz BW 20 MHz				
Frequency	RMS (EIRP)	Limit	Margin	Correction Factor
MHz	dBm	dBm	dB	dB
153.8	-55.6	-25.0	30.6	-100.1
1228.5	-46.8	-25.0	21.8	-63.3
2250.0	-43.1	-25.0	18.1	-60.3
2919.5	-41.9	-25.0	16.9	-59.1
8013.5	-43.1	-25.0	18.1	-87.7
13355.0	-58.9	-25.0	33.9	-93.7

LTE 48 – Antenna Vendor 1

30MHz to 40GHz – Tx Radiated Spurious LTE 48 - QPSK - High channel – 3690 MHz BW 20 MHz				
Frequency	RMS (EIRP)	Limit	Margin	Correction Factor
MHz	dBm	dBm	dB	dB
153.8	-55.8	-40.0	15.8	-100.1
2039.0	-51.8	-40.0	11.8	-79.8
5444.0	-50.9	-40.0	10.9	-81.2
7992.0	-49.5	-40.0	9.5	-77.7
8734.0	-50.0	-40.0	10.0	-77.0
10848.0	-42.5	-40.0	2.5	-85.0

LTE 66 – Antenna Vendor 1

30MHz to 18GHz – Tx Radiated Spurious LTE 66 - QPSK - High channel – 1770 MHz BW 20 MHz				
Frequency	RMS (EIRP)	Limit	Margin	Correction Factor
MHz	dBm	dBm	dB	dB
153.8	-55.5	-13.0	42.5	-100.1
1226.5	-46.8	-13.0	33.8	-63.3
2422.5	-42.5	-13.0	29.5	-60.0
2932.5	-41.3	-13.0	28.3	-59.1
9579.0	-48.6	-13.0	35.6	-86.0
17247.0	-58.3	-13.0	45.3	-89.4

LTE 71 – Antenna Vendor 2**30MHz to 18GHz – Tx Radiated Spurious
LTE 71 - QPSK - Mid channel – 680.5 MHz
BW 20 MHz**

Frequency	RMS (ERP)	Limit	Margin	Correction Factor
MHz	dBm	dBm	dB	dB
30.3	-34.4	-13.0	19.3	-61.9
758.1	-33.1	-13.0	18.0	-63.8
964.7	-32.5	-13.0	17.4	-62.3
2014.5	-49	-13.0	33.9	-97.8
3997.0	-56.1	-13.0	41.0	-92.0
6309.0	-53	-13.0	37.9	-89.6

B.1.3.2 UL carrier aggregation LTE (Intra-band)
LTE_ULCA_5B – Antenna Vendor 1

30MHz to 9.5GHz – Tx Radiated Spurious LTE 5 - QPSK - Mid channel – 831.6 MHz / 841.5 MHz BW 10MHz / 10MHz				
Frequency	RMS (ERP)	Limit	Margin	Correction Factor
MHz	dBm	dBm	dB	dB
39.7	-30.5	-13.0	15.4	-66.7
562.5	-32	-13.0	16.9	-65.2
3374.8	-59	-13.0	43.9	-85.6
6978.1	-51.4	-13.0	36.3	-78.9
12133.3	-43.7	-13.0	28.6	-71.2
16560.1	-35.7	-13.0	20.6	-62.9

LTE_ULCA_66B – Antenna Vendor 1

30MHz to 18GHz – Tx Radiated Spurious LTE 66 - QPSK - Mid channel – 1752.6 MHz / 1761.9 MHz BW 15MHz / 5MHz				
Frequency	RMS (EIRP)	Limit	Margin	Correction Factor
MHz	dBm	dBm	dB	dB
39.5	-55.8	-13.0	42.8	-94.0
911.8	-59.9	-13.0	46.9	-90.1
3892.5	-55.2	-13.0	42.2	-84.3
5782.2	-51.1	-13.0	38.1	-80.6
12447.6	-41.8	-13.0	28.8	-70.8
14067.2	-39.8	-13.0	26.8	-69.5
16928.0	-58.7	-13.0	45.6	-90.1

LTE ULCA 7C – Antenna Vendor 1

**30MHz to 26.5GHz – Tx Radiated Spurious
LTE 7 - QPSK - High channel – 2540.2 MHz / 2560 MHz
BW 20MHz / 20MHz**

Frequency	RMS (EIRP)	Limit	Margin	Correction Factor
MHz	dBm	dBm	dB	dB
39.7	-56.7	-25.0	31.8	-94.1
3253.0	-37.5	-25.0	12.5	-55.2
4402.0	-54.1	-25.0	29.1	-82.4
6893.8	-49.8	-25.0	24.8	-78.5
10927.8	-44.8	-25.0	19.8	-72.8
24969.5	-54.9	-25.0	29.9	-83.3

LTE ULCA 41C – Antenna Vendor 1

**30MHz to 26.5GHz – Tx Radiated Spurious
LTE 41 - QPSK - Low channel – 2506.0 MHz / 2525.8 MHz
BW 20MHz / 20MHz**

Frequency	RMS (EIRP)	Limit	Margin	Correction Factor
MHz	dBm	dBm	dB	dB
39.3	-55.8	-25.0	30.8	-94.0
153.8	-55.4	-25.0	30.4	-100.1
897.5	-57.6	-25.0	32.6	-90.1
5031.5	-51.9	-25.0	26.9	-82.6
7549.0	-49.7	-25.0	24.7	-78.4
25926.0	-56.3	-25.0	31.3	-83.0

B.2 Declared ERP / EIRP

	Band	Form-Factor	WWAN Antenna	Tx Antenna	Conducted Power (dBm)	Antenna Gain (dBi)	ERP / EIRP (dBm)	ERP / EIRP (W)
WCDMA	WCDMA II	Notebook PC	Vendor 1	Ant 5	24.5	0.63	25.13	0.33
	WCDMA IV	Notebook PC	Vendor 1	Ant 5	24.5	1.73	26.23	0.42
	WCDMA V*	Notebook PC	Vendor 1	Ant 5	24.5	-1.07	23.43	0.22
LTE	LTE 2	Notebook PC	Vendor 1	Ant 5	24.0	1.92	25.92	0.39
	LTE 7	Notebook PC	Vendor 1	Ant 5	24.0	1.92	25.92	0.39
	LTE12*	Notebook PC	Vendor 1	Ant 5	24.0	-0.31	23.69	0.23
	LTE 13*	Notebook PC	Vendor 1	Ant 5	24.0	1.98	25.98	0.40
	LTE14*	Notebook PC	Vendor 1	Ant 5	24.0	1.49	25.49	0.35
	LTE 25	Notebook PC	Vendor 1	Ant 5	24.0	0.63	24.63	0.29
	LTE 26*	Notebook PC	Vendor 1	Ant 5	24.0	-1.07	22.93	0.20
	LTE 30	Notebook PC	Vendor 1	Ant 5	23.0	0.98	23.98	0.25
	LTE 41	Notebook PC	Vendor 1	Ant 5	24.0	1.95	25.95	0.39
	LTE 48	Notebook PC	Vendor 1	Ant 5	22.0	-0.08	21.92	0.16
	LTE 66	Notebook PC	Vendor 1	Ant 5	24.0	1.73	25.73	0.37
	LTE71*	Notebook PC	Vendor 2	Ant 5	24.0	-2.47	21.53	0.14

* ERP values