

TEST REPORT

EUT Description	Convertible PC
Brand Name	HP
Model Name	HSN-I46C
FCC ID	B94HNI46CKL
Date of Test Start/End	2021-11-02 / 2021-12-08
Features	WWAN (5G NR, LTE, UMTS), WLAN, BT (see section 6)
Description	FM350-GL + HB antenna

Applicant	HP Inc.
Address (FCC)	1501 Page Mill Road, Palo Alto CA 94304 USA
Contact Person	Cindy Su
Telephone/Fax/ Email	+886 2 37895951/cindy.su@hp.com

Reference Standards	FCC 47 CFR Part §2.1093 (see section 1)	
RF Exposure Environment	Portable devices - General population/uncontrolled exposure	
Exposure Conditions	Body worn	
	SAR Result	SAR Limit
Maximum SAR Result & Limit	1.41 W/kg (1g)	1.60 W/kg (1g)
Min. test separation distance	0mm to phantom, 2.05mm to antenna edge	

Test Report identification	210916-05.TR08
Revision Control	Rev. 00 This test report revision replaces any previous test report revision (see section 9)

The test results relate only to the samples tested.
Reference to accreditation shall be used only by full reproduction of test report.

_____ Issued by _____ Reviewed by _____

Edgar GARCIA
(Test Lead Engineer)

Ines KHARRAT
(Technical Manager)

Table of Contents

- 1. Standards, reference documents and applicable test methods 4**
- 2. General conditions, competences and guarantees 4**
- 3. Preface 5**
- 4. Environmental Conditions 6**
- 5. Test samples 6**
- 6. EUT Features 7**
- 7. Remarks and comments 14**
- 8. Test Verdicts summary 14**
- 9. Document Revision History 14**
- Annex A. Test & System Description 15**
 - A.1 SAR DEFINITION 15
 - A.2 SAR MEASUREMENT SYSTEM 16
 - A.2.1 SAR Measurement Setup 16
 - A.2.2 E-Field Measurement Probe 17
 - A.2.3 SAM Phantom 17
 - A.2.4 Flat Phantom 18
 - A.2.5 Device Positioner 18
 - A.3 DATA EVALUATION 19
 - A.4 SYSTEM AND LIQUID CHECK 21
 - A.4.1 System Check 21
 - A.4.2 Liquid Check 22
 - A.5 TEST EQUIPMENT LIST 23
 - A.5.1 SAR System #2 23
 - A.5.2 SAR System #4 23
 - A.5.3 Shared Instrumentation 24
 - A.5.4 Tissue Simulant Liquid 24
 - A.6 MEASUREMENT UNCERTAINTY EVALUATION 25
 - A.7 RF EXPOSURE LIMITS 26
- Annex B. Test Results 27**
 - B.1 TEST CONDITIONS 27
 - B.1.1 Test SAR Test positions relative to the phantom 27
 - B.1.2 Test signal, Output power and Test Frequencies 28
 - B.1.3 Evaluation Exclusion and Test Reductions 29
 - B.2 CONDUCTED POWER MEASUREMENTS – TABLET MODE 32
 - B.2.1 WCDMA/ HSPA/ DC-HSPA 32
 - B.2.2 LTE 35
 - B.2.3 LTE UL Carrier Aggregation 68
 - B.2.4 5G NR (FR1) Tablet Mode 70
 - B.3 TISSUE PARAMETERS MEASUREMENT 83
 - B.3.1 System Check Measurements 84
 - B.4 SAR TABLET TEST RESULTS 86
 - B.4.1 WCDMA 86
 - B.4.2 LTE 87
 - B.4.3 5G NR 94
 - B.4.4 SAR Measurement Variability 98
 - B.4.5 Simultaneous Transmission SAR Evaluation 99

- Annex C. Test System Plots..... 104**
- Annex D. TSL Dielectric Parameters 147**
 - D.1 BODY 600MHZ-900MHZ 147
 - D.2 BODY 1700MHZ-2000MHZ 151
 - D.3 BODY 2300MHZ-2700MHZ 155
 - D.4 BODY 3500MHZ-3900MHZ 159
- Annex E. Calibration Certificates 163**
- Annex F. Photographs 165**
 - F.1 TEST SAMPLES 165
 - F.2 TEST POSITIONS..... 167
 - F.3 ANTENNA HOST PLATFORM LOCATION AND ADJACENT EDGE POSITIONS RELATIVE TO THE BODY..... 168
 - F.4 PHANTOM LIQUID LEVEL DURING MEASUREMENTS 169

1. Standards, reference documents and applicable test methods

FCC	<ol style="list-style-type: none">1. FCC Title 47 CFR Part §2.1093 – Radiofrequency radiation exposure evaluation: portable devices. 2019-10-01 Edition2. FCC OET KDB 447498 D01 v06 – RF Exposure Procedures and Equipment Authorization Policies for Mobile and Portable Devices.3. FCC OET KDB 616217 D04 v01r02 – SAR Evaluation Considerations for Laptop, Notebook, Netbook and Tablet Computers.4. FCC OET KDB 865664 D01 v01r04 – SAR Measurement Requirements for 100 MHz to 6 GHz.5. FCC OET KDB 865664 D02 v01r02 – RF Exposure Compliance Reporting and Documentation Considerations.6. FCC OET KDB 941225 D05 v02r05 – SAR Evaluation Considerations for LTE Devices.7. FCC OET KDB 941225 D01 v03r01 – 3G SAR Measurement Procedures.8. IEEE Std 1528-2013 – IEEE Recommended Practice Determining the Peak Spatial-Average Specific Absorption Rate (SAR) in the Human Head from Wireless Communication Devices: Measurement Techniques...9. TCB Workshop Nov 2017; LTE UL/DL Carrier Aggregation SAR10. TCB workshop November 2019; RF Exposure Policy Updates (5G NR FR1 NSA EN-DC UE SAR Evaluations), the FCC OET KDB 941225 D05 rules apply.
-----	---

2. General conditions, competences and guarantees

- ✓ Tests performed under FCC standards identified in section 1 are covered by A2LA accreditation.
- ✓ Intel Corporation SAS Wireless RF Lab (Intel WRF Lab) is an ISO/IEC 17025:2017 laboratory accredited by the American Association for Laboratory Accreditation (A2LA) with the certificate number 3478.01.
- ✓ Intel Corporation SAS Wireless RF Lab (Intel WRF Lab) is an Accredited Test Firm recognized by the FCC, with Designation Number FR0011.
- ✓ Intel WRF Lab declines any responsibility with respect to the identified information provided by the customer and that may affect the validity of results.
- ✓ Intel WRF Lab only provides testing services and is committed to providing reliable, unbiased test results and interpretations.
- ✓ Intel WRF Lab is liable to the client for the maintenance of the confidentiality of all information related to the item under test and the results of the test.
- ✓ Intel WRF Lab has developed calibration and proficiency programs for its measurement equipment to ensure correlated and reliable results to its customers.
- ✓ This report is only referred to the item that has undergone the test.
- ✓ This report does not imply an approval of the product by the Certification Bodies or competent Authorities.

3. Preface

The HSN-I46C convertible PC includes the Time Averaging SAR (TAS) concept. The TAS algorithm is implemented in the Fibocom M2 FM350-GL modem, which is embedded in the FM350-GL cellular module (FCC ID: ZMOFM350GL).

The implementation details and TAS operating characteristics are described in a separated document [1]. The validation of algorithm operations is performed by Intel Corporation according to the range of commonly used accessible control parameters used for typical host products. The validation results are reported in document [2].

The FCC SAR limit is a time averaged exposure metric. At host level, the normally required SAR test procedures are applicable for SAR compliance testing at upper-threshold values of the algorithm, which is the maximum output power level for continuous time-averaging operations TAS algorithm enforces. The reliability of this has been demonstrated by results in the Algorithm Validation Test Report [2].

The model supports simultaneous transmission of WWAN, BT and WLAN. The TAS algorithm is only applied to WWAN cellular module. The WLAN / BT SAR evaluation is presented in the document [3].

The SAR evaluation of WWAN is performed in this report as well as the RF exposure assessment for simultaneous transmission of WWAN, WLAN and BT.

[1] 210317_TAS_Operational_Report_Rev01

[2] 201029-02.TR01_Rev01_Validation Report for 5G Time Averaging Algorithm

[3] 210916-04.TR01 - HSN-I46C wAX211NGW WLAN_WWAN – Legacy

[4] 210916-04.TR02 - HSN-I46C wAX211NGW WLAN_WWAN – WiFi 6E

4. Environmental Conditions

- ✓ At the site where the measurements were performed the following limits were not exceeded during the tests:

Temperature	22°C ± 2°C
Humidity	44.0% ± 20%
Liquid Temperature	21.5°C ± 2°C

5. Test samples

Sample	Control #	Description	Model	Serial #	Date of receipt	Note
#01	210916-05.S05	Convertible PC	HSN-I46C	00017609D3	2021-09-23	Used for 5G NR tests
#02	210916-05.S06	Convertible PC	HSN-I46C	00017609DK	2021-09-23	Used for LTE and WCDMA tests

6. EUT Features

Brand Name	HP
Model Name	HSN-I46C
Prototype / Production	Production
Host Identification	HP HSN-I46C + FM350-GL

Supported radios

The module is a data only DUT supporting 5G NR, UMTS and LTE, with carrier aggregation. The applicable frequency bands and operating modes are identified in the following table, where North America bands are shown in **bold**.

WWAN:

Mode	Bands	Supported Tx Mode			
		WCDMA	HSDPA	HSUPA	DC-HSDPA
WCDMA / HSPA+	FDD II (1850.0 – 1910.0 MHz)	✓	✓	✓	✓
	FDD IV (1710.0 – 1755.0 MHz)	✓	✓	✓	✓
	FDD V (824.0 – 849.0 MHz)	✓	✓	✓	✓

FDD/TDD	Bands	Modulations	Bandwidth					
			1.4	3	5	10	15	20
LTE FDD	Band 2 (1850.0 – 1910.0 MHz)	QPSK/16QAM/64QAM/256QAM	✓	✓	✓	✓	✓	✓
	Band 4 (1710.0 – 1755.0 MHz)	QPSK/16QAM/64QAM/256QAM	✓	✓	✓	✓	✓	✓
	Band 5 (824.0 – 849.0 MHz)	QPSK/16QAM/64QAM/256QAM	✓	✓	✓	✓		
	Band 7 (2500.0 – 2570.0 MHz)	QPSK/16QAM/64QAM/256QAM			✓	✓	✓	✓
	Band 12 (699.0 – 716.0 MHz)	QPSK/16QAM/64QAM/256QAM	✓	✓	✓	✓		
	Band 13 (777.0 – 787.0 MHz)	QPSK/16QAM/64QAM/256QAM			✓	✓		
	Band 14 (788.0 – 798.0 MHz)	QPSK/16QAM/64QAM/256QAM			✓	✓		
	Band 17 (704.0 – 716.0 MHz)	QPSK/16QAM/64QAM/256QAM			✓	✓		
	Band 25 (1850.0 – 1915.0 MHz)	QPSK/16QAM/64QAM/256QAM	✓	✓	✓	✓	✓	✓
	Band 26 (814.0 – 849.0 MHz)	QPSK/16QAM/64QAM/256QAM	✓	✓	✓	✓	✓	
	Band 30 (2305.0 – 2315.0 MHz)	QPSK/16QAM/64QAM/256QAM			✓	✓		
LTE TDD	Band 66 (1710.0 – 1780.0 MHz)	QPSK/16QAM/64QAM/256QAM	✓	✓	✓	✓	✓	✓
	Band 38 (2570.0 – 2620.0 MHz)	QPSK/16QAM/64QAM/256QAM			✓	✓	✓	✓
	Band 41 (2496.0 – 2690.0 MHz)	QPSK/16QAM/64QAM/256QAM			✓	✓	✓	✓
	Band 48 (3550.0 – 3700.0 MHz)	QPSK/16QAM/64QAM/256QAM			✓	✓	✓	✓

Bands	Modulation	SCS (KHz)	Bandwidth													
			5	10	15	20	25	30	40	50	60	70	80	90	100	
N2 FDD (1850.0 – 1910.0 MHz)	P1/2 BPSK QPSK 16QAM 64QAM 256QAM	15 30	✓	✓	✓	✓										
N5 FDD (824.0 – 849.0 MHz)	PV2 BPSK QPSK 16QAM 64QAM 256QAM	15 30 60	✓	✓	✓	✓										
N7 FDD (2500.0 – 2570.0 MHz)	PV2 BPSK QPSK 16QAM 64QAM 256QAM	15 30	✓	✓	✓	✓										
N25 FDD (1850.0 – 1915 MHz)	PV2 BPSK QPSK 16QAM 64QAM 256QAM	15 30	✓	✓	✓	✓										
N30 FDD (2305.0 – 2315.0 MHz)	PV2 BPSK QPSK 16QAM 64QAM 256QAM	15 30	✓	✓												
N38 TDD (2570.0 – 2620.0 MHz)	PV2 BPSK QPSK 16QAM 64QAM 256QAM	15 30 60	✓	✓	✓	✓			✓	✓						
N41 TDD (2496.0 – 2690.0 MHz)	PV2 BPSK QPSK 16QAM 64QAM 256QAM	15 30				✓			✓	✓	✓	✓	✓	✓	✓	✓
N66 FDD (1710.0 – 1780.0 MHz)	PV2 BPSK QPSK 16QAM 64QAM 256QAM	15 30	✓	✓	✓	✓	✓	✓	✓	✓						
N77 TDD* (3700.0 – 3980.0 MHz)	PV2 BPSK QPSK 16QAM 64QAM 256QAM	15 30		✓	✓	✓	✓	✓	✓	✓	✓	✓	✓	✓	✓	✓
N78 TDD** (3700.0 – 3800.0 MHz)	PV2 BPSK QPSK 16QAM 64QAM 256QAM	15 30		✓	✓	✓	✓	✓	✓	✓	✓	✓	✓	✓	✓	✓

*FCC limits 5G NR B77 to 3700-3980MHz

** FCC limits 5G NR B78 to 3700-3800MHz

UL carrier aggregation LTE (Inter-Band)	UL carrier aggregation LTE (Intra-band)
2A – 5A	5B
2A – 12A	7C
2A – 13A	38C
2A – 14A	41C
2A – 48A	48C
4A – 5A	66B
4A – 12A	66C
4A – 13A	
5A – 7A	
5A – 30A	
5A – 48A	
5A – 66A	
12A – 30A	
12A – 66A	
13A – 48A	
13A – 66A	
14A – 30A	
14A – 66A	
25A – 26A	
48A – 66A	

EN/DC possible combinations	
NR 5G Band	Associated LTE Bands
N2A	5, 12, 13, 14
N5A	2, 7, 30, 66, 48
N66A	5, 12, 13, 48
N41A	2,66,41
N77A	2,5,12,13,14, 30,66, 41
N78A	2, 5, 7, 38

UL carrier aggregation 5G FR1
n2A – n5A
n5A – n66A

WLAN

Mode	UL Freq Range
802.11b/g/n/ax	2.4GHz (2400.0 – 2483.5 MHz)
802.11a/n/ac/ax	5.2GHz (5150.0 – 5250.0 MHz)
	5.3GHz (5250.0 – 5350.0 MHz)
	5.6GHz (5470.0 – 5725.0 MHz)
	5.8GHz (5725.0 – 5825.0 MHz)
802.11ax	6.0GHz (5925.0 – 7125.0 MHz)
Bluetooth & BLE v5.2	2.4GHz (2400.0 – 2483.5 MHz)

Antenna Information “information provided by the applicant”

The DUTs have 2 WWAN TX antennas:

Transmitter	Main (Antenna 5)	Aux (Antenna 8)
Manufacturer	HongBo	HongBo
Antenna type	PIFA antenna	PIFA antenna
Part number	6036B0313201 (00-3302700850)	6036B0313201 (00-3302700850)

See Annex F for more details on antennas location.

WWAN Antenna Mapping

Configuration	Main (Ant 5)	Aux (Ant 8)
WCDMA	LB / MHB	
LTE	LB / MHB	
		UHB
NR 5G SA	(LB / MHB)	
		UHB
LTE ULCA	LB	MHB /UHB
	MHB	UHB
	B41	UHB
NR 5G ENDC	LB	MHB / B41
	B41	N41
	MHB	B41/N41
	B41/N41	UHB
	MHB	UHB
NR 5G ULCA	LB	MHB

- LB: WCDMA FDD V, LTE B5/12/13/14/17/26, 5G NR n5
- MHB: WCDMA FDD II/ FDD IV, LTE B2/4/7/25/30/66/38, 5G NR n2/n7/n25/n30/n38/n66
- UHB: LTE: B41/48; NR 5G: n41/n77/n78

Note: For EN-DC mode the 4G and 5G carriers transmit on separate antennas.
For inter-bands on LTE and NR 5G ULCA the carriers transmit on separate antennas.

Simultaneous Transmission Configurations

- WWAN Main (Ant5) + WWAN Aux (Ant8) + WLAN 2.4GHz Main + BT Aux
- WWAN Main (Ant5) + WWAN Aux (Ant8) + WLAN 2.4GHz Main + WLAN 2.4GHz Aux
- WWAN Main (Ant5) + WWAN Aux (Ant8) + WLAN 5GHz Main + BT Aux
- WWAN Main (Ant5) + WWAN Aux (Ant8) + WLAN 5GHz Main + WLAN 5GHz Aux
- WWAN Main (Ant5) + WWAN Aux (Ant8) + WLAN 5GHz Main + WLAN 5GHz Aux + BT Aux
- WWAN Main (Ant5) + WWAN Aux (Ant8) + WLAN 6GHz Main + BT Aux
- WWAN Main (Ant5) + WWAN Aux (Ant8) + WLAN 6GHz Main + WLAN 6GHz Aux
- WWAN Main (Ant5) + WWAN Aux (Ant8) + WLAN 6GHz Main + WLAN 6GHz Aux + BT Aux

WLAN transmitter is considered in this report just for the simultaneous transmission evaluation with the WWAN module (See section B.4.5)

Additional information

- 5.60-5.65 GHz band (TDWR) is supported by the device
- Band gap is supported by the device
- Two different power settings are implemented in the DUT:
 - Max power for Notebook mode
 - Reduced power for Tablet mode
- Maximum Power Reduction (MPR) is implemented according to 3GPP, and it is a permanent feature, built-in by design on the tune-up power:

Modulation	Channel bandwidth / #RB						MPR (Db)
	1.4 MHz	3.0 MHz	5 MHz	10 MHz	15 MHz	20 MHz	
QPSK	> 5	> 4	> 8	> 12	> 16	> 18	≤ 1
16 QAM	≤ 5	≤ 4	≤ 8	≤ 12	≤ 16	≤ 18	≤ 1
16 QAM	> 5	> 4	> 8	> 12	> 16	> 18	≤ 2
64 QAM	≤ 5	≤ 4	≤ 8	≤ 12	≤ 16	≥ 18	≤ 2
64 QAM	> 5	> 4	> 8	> 12	> 16	> 18	≤ 3
256 QAM	≥ 1						≤ 5

The DUT uses the maximum MPR values described in the above.

The maximum power reduction is applicable on the Tune up tolerance.

- According to 3GPP 38-101-1, the UE is allowed to reduce the maximum output power due to higher order modulations and for channel bandwidths that meets both following criteria:
 - Channel bandwidth ≤ 100MHz.
 - Relative channel bandwidth ≤ 4% for TDD bands and ≤ 3% for FDD bands

Maximum power reduction (MPR) for power class 3			
Modulation	MPR (dB)		
	Edge RB allocations	Outer RB allocations	Inner RB allocations
DFT-s-OFDM PI/2 BPSK	≤ 3.5 ¹	≤ 1.2 ¹	≤ 0.2 ¹
	0.5 ²	0.5 ²	0 ²
DFT-s-OFDM QPSK	≤ 1		0
DFT-s-OFDM 16 QAM	≤ 2		≤ 1
DFT-s-OFDM 64 QAM	≤ 2.5		
DFT-s-OFDM 256 QAM	4.5		
CP-OFDM QPSK	≤ 3	≤ 1.5	
CP-OFDM 16 QAM	≤ 3	≤ 2	
CP-OFDM 64 QAM	≤ 3.5		
CP-OFDM 256 QAM	≤ 6.5		

NOTE 1: Applicable for UE operating in TDD mode with PI/2 BPSK modulation and if the IE [P-Boost-BPSK] is set to 1 and 40% or less slots in radio frame are used for UL transmission for bands n40, n77, n78 and n79.
 NOTE 2: Applicable for UE operating in FDD mode, or in TDD mode in bands other than n40, n77, n78 and n79 and if the IE [Pboost-BPSK] is set to 0 and if more than 40% of slots in radio frame are used for UL transmission for bands n40, n77, n78 and n79.

Maximum power reduction (MPR) for power class 2			
Modulation	MPR (dB)		
	Edge RB allocations	Outer RB allocations	Inner RB allocations
DFT-s-OFDM PI/2 BPSK	≤ 3.5	≤ 0.5	0
DFT-s-OFDM QPSK	≤ 3.5	≤ 1	0
DFT-s-OFDM 16 QAM	≤ 3.5	≤ 2	≤ 1
DFT-s-OFDM 64 QAM	≤ 3.5	≤ 2.5	
DFT-s-OFDM 256 QAM	≤ 4.5		
CP-OFDM QPSK	≤ 3.5	≤ 3	≤ 1.5
CP-OFDM 16 QAM	≤ 3.5	≤ 3	≤ 2
CP-OFDM 64 QAM	≤ 3.5		
CP-OFDM 256 QAM	≤ 6.5		

The following table indicates the power levels and tolerance for tablet mode:

Maximum Output power specification + Tune up tolerance

Mode	Tx Antenna	Technology	Bands	Class	Nominal (dBm)	Tolerance dB	Lower Tolerance (dBm)	Upper Tolerance (dBm)
Tablet	5	WCDMA/HSPA	FDD II (1850.0 – 1910.0 MHz)	3	15.5	±1	14.5	16.5
	5	WCDMA/HSPA	FDD IV (1710.0 – 1755.0 MHz)	3	18.0	±1	17.0	19.0
	5	WCDMA/HSPA	FDD V (824.0 – 849.0 MHz)	3	19.5	±1	18.5	20.5
	5	LTE	B2 (1850.0 – 1910.0 MHz)	3	15.5	±1	14.5	16.5
	5	LTE	B4 (1710.0 – 1755.0 MHz)	3	18.0	±1	17.0	19.0
	5	LTE	B5 (824.0 – 849.0 MHz)	3	19.5	±1	18.5	20.5
	5	LTE	B7 (2500.0 – 2570.0 MHz)	3	13.0	±1	12.0	14.0
	5	LTE	B12 (699.0 – 716.0 MHz)	3	18.5	±1	17.5	19.5
	5	LTE	B13 (777.0 – 787.0 MHz)	3	18.5	±1	17.5	19.5
	5	LTE	B14 (788.0 – 798.0 MHz)	3	18.5	±1	17.5	19.5
	5	LTE	B17 (704.0 – 716.0 MHz)	3	18.5	±1	17.5	19.5
	5	LTE	B25 (1850.0 – 1915.0 MHz)	3	15.5	±1	14.5	16.5
	5	LTE	B26 (814.0 – 849.0 MHz)	3	19.0	±1	18.0	20.0
	5	LTE	B30 (2305.0 – 2315.0 MHz)	3	16.0	±1	15.0	17.0
	5	LTE	B38 (2570.0 – 2620.0 MHz)	3	14.0	±1	13.0	15.0
	5	LTE	B41 (2496.0 – 2690.0 MHz)	3	15.0	±1	14.0	16.0
	5	LTE	B41 (2496.0 – 2690.0 MHz)	2	15.0	±1	14.0	16.0
	5	LTE	B66 (1710.0 – 1780.0 MHz)	3	18.0	±1	17.0	19.0
	8	LTE	B2 (1850.0 – 1910.0 MHz)	3	18.0	±1	17.0	19.0
	8	LTE	B4 (1710.0 – 1755.0 MHz)	3	18.0	±1	17.0	19.0
	8	LTE	B7 (2500.0 – 2570.0 MHz)	3	13.0	±1	12.0	14.0
	8	LTE	B25 (1850.0 – 1915.0 MHz)	3	18.0	±1	17.0	19.0
	8	LTE	B30 (2305.0 – 2315.0 MHz)	3	15.5	±1	14.5	16.5
	8	LTE	B41 (2496.0 – 2690.0 MHz)	3	13.0	±1	12.0	14.0
	8	LTE	B41 (2496.0 – 2690.0 MHz)	2	13.0	±1	12.0	14.0
	8	LTE	B48 (3550.0 – 3700.0 MHz)	3	14.0	±1	13.0	15.0
	8	LTE	B66 (1710.0 – 1780.0 MHz)	3	17.5	±1	16.5	18.5
	5	5G NR	N2 (1850.0 – 1910.0 MHz)	3	15.5	±1	14.5	16.5
	5	5G NR	N5 (824.0 – 849.0 MHz)	3	19.5	±1	18.5	20.5
	5	5G NR	N7 (2500.0 – 2570.0 MHz)	3	13.0	±1	12.0	14.0
	5	5G NR	N25 (1850.0 – 1915.0 MHz)	3	15.5	±1	14.5	16.5
	5	5G NR	N30 (2305.0 – 2315.0 MHz)	3	17.0	±1	16.0	18.0
	5	5G NR	N38 (2570.0 – 2620.0 MHz)	3	14.0	±1	13.0	15.0
	5	5G NR	N41 (2496.0 – 2690.0 MHz)	3	14.0	±1	13.0	15.0
	5	5G NR	N41 (2496.0 – 2690.0 MHz)	2	14.0	±1	13.0	15.0
	5	5G NR	N66 (1710.0 – 1780.0 MHz)	3	18.0	±1	17.0	19.0
	5	5G NR	N77 (3700.0 – 3980.0 MHz)	3	15.0	±1	14.0	16.0
	5	5G NR	N77 (3700.0 – 3980.0 MHz)	2	15.0	±1	14.0	16.0
	5	5G NR	N78 (3700.0 – 3800.0 MHz)	3	13.0	±1	12.0	14.0
	5	5G NR	N78 (3700.0 – 3800.0 MHz)	3	13.0	±1	12.0	14.0
	8	5G NR	N2 (1850.0 – 1910.0 MHz)	3	17.0	±1	16.0	18.0
	8	5G NR	N38 (2570.0 – 2620.0 MHz)	3	13.5	±1	12.5	14.5
8	5G NR	N41 (2496.0 – 2690.0 MHz)	3	13.0	±1	12.0	14.0	
8	5G NR	N41 (2496.0 – 2690.0 MHz)	2	13.0	±1	12.0	14.0	
8	5G NR	N66 (1710.0 – 1780.0 MHz)	3	18.0	±1	17.0	19.0	
8	5G NR	N77 (3700.0 – 3980.0 MHz)	3	14.0	±1	13.0	15.0	
8	5G NR	N77 (3700.0 – 3980.0 MHz)	2	14.0	±1	13.0	15.0	
8	5G NR	N78 (3700.0 – 3800.0 MHz)	3	14.5	±1	13.5	15.5	
8	5G NR	N78 (3700.0 – 3800.0 MHz)	3	14.5	±1	13.5	15.5	

As mentioned in Section 3, the SAR compliance testing is performed at upper-threshold values of the algorithm, which is the maximum output power level for continuous time-averaging operations TAS algorithm enforces.

In TAS operation, the control parameters including the upper-threshold value are stored in NVM. They are inaccessible to the normal users and no other interface is available for changing these control parameters. The table below shows the upper-threshold values used as continuous power for SAR testing as well as the different TAS parameters defined in [1] and [2] of section 3, to be embedded in the host:

Mode	Tx Antenna	Technology	Bands	Class	Nominal Full Power (dBm)	Upper Threshold (dBm)	Lower Threshold (dBm)	DPR_ON Power (dBm)
Tablet	5	WCDMA/HSPA	FDD II (1850.0 – 1910.0 MHz)	3	23.5	15.5	14.5	13.5
	5	WCDMA/HSPA	FDD IV (1710.0 – 1755.0 MHz)	3	23.5	18.0	17.0	16.0
	5	WCDMA/HSPA	FDD V (824.0 – 849.0 MHz)	3	23.5	19.5	18.5	17.5
	5	LTE	B2 (1850.0 – 1910.0 MHz)	3	23.0	15.5	14.5	13.5
	5	LTE	B4 (1710.0 – 1755.0 MHz)	3	23.0	18.0	17.0	16.0
	5	LTE	B5 (824.0 – 849.0 MHz)	3	23.0	19.5	18.5	17.5
	5	LTE	B7 (2500.0 – 2570.0 MHz)	3	23.0	13.0	12.0	11.0
	5	LTE	B12 (699.0 – 716.0 MHz)	3	23.0	18.5	17.5	16.5
	5	LTE	B13 (777.0 – 787.0 MHz)	3	23.0	18.5	17.5	16.5
	5	LTE	B14 (788.0 – 798.0 MHz)	3	23.0	18.5	17.5	16.5
	5	LTE	B17 (704.0 – 716.0 MHz)	3	23.0	18.5	17.5	16.5
	5	LTE	B25 (1850.0 – 1915.0 MHz)	3	23.0	15.5	14.5	13.5
	5	LTE	B26 (814.0 – 849.0 MHz)	3	23.0	19.0	18.0	17.0
	5	LTE	B30 (2305.0 – 2315.0 MHz)	3	23.0	16.0	15.0	14.0
	5	LTE	B38 (2570.0 – 2620.0 MHz)	3	23.0	14.0	13.0	12.0
	5	LTE	B41 (2496.0 – 2690.0 MHz)	3	23.0	15.0	14.0	13.0
	5	LTE	B41 (2496.0 – 2690.0 MHz)	2	27.0	15.0	14.0	13.0
	5	LTE	B66 (1710.0 – 1780.0 MHz)	3	23.0	18.0	17.0	16.0
	8	LTE	B2 (1850.0 – 1910.0 MHz)	3	23.0	18.0	17.0	16.0
	8	LTE	B4 (1710.0 – 1755.0 MHz)	3	23.0	18.0	17.0	16.0
	8	LTE	B7 (2500.0 – 2570.0 MHz)	3	23.0	13.0	12.0	11.0
	8	LTE	B25 (1850.0 – 1915.0 MHz)	3	23.0	18.0	17.0	16.0
	8	LTE	B30 (2305.0 – 2315.0 MHz)	3	23.0	15.5	14.5	13.5
	8	LTE	B41 (2496.0 – 2690.0 MHz)	3	23.0	13.0	12.0	11.0
	8	LTE	B41 (2496.0 – 2690.0 MHz)	2	27.0	13.0	12.0	11.0
	8	LTE	B48 (3550.0 – 3700.0 MHz)	3	21.0	14.0	13.0	12.0
	8	LTE	B66 (1710.0 – 1780.0 MHz)	3	23.0	17.5	16.5	15.5
	5	5G NR	N2 (1850.0 – 1910.0 MHz)	3	23.0	15.5	14.5	13.5
	5	5G NR	N5 (824.0 – 849.0 MHz)	3	23.0	19.5	18.5	17.5
	5	5G NR	N7 (2500.0 – 2570.0 MHz)	3	23.0	13.0	12.0	11.0
	5	5G NR	N25 (1850.0 – 1915.0 MHz)	3	23.0	15.5	14.5	13.5
	5	5G NR	N30 (2305.0 – 2315.0 MHz)	3	23.0	17.0	16.0	15.0
	5	5G NR	N38 (2570.0 – 2620.0 MHz)	3	23.0	14.0	13.0	12.0
	5	5G NR	N41 (2496.0 – 2690.0 MHz)	3	23.0	15.0	14.0	13.0
	5	5G NR	N41 (2496.0 – 2690.0 MHz)	2	23.0	15.0	14.0	13.0
	5	5G NR	N66 (1710.0 – 1780.0 MHz)	3	23.0	18.0	17.0	16.0
	5	5G NR	N77 (3700.0 – 3980.0 MHz)	3	23.0	15.0	14.0	13.0
	5	5G NR	N77 (3700.0 – 3980.0 MHz)	2	27.0	15.0	14.0	13.0
	5	5G NR	N78 (3700.0 – 3800.0 MHz)	3	23.0	13.0	12.0	11.0
	5	5G NR	N78 (3700.0 – 3800.0 MHz)	3	27.0	13.0	12.0	11.0
	8	5G NR	N2 (1850.0 – 1910.0 MHz)	3	23.0	17.0	16.0	15.0
	8	5G NR	N38 (2570.0 – 2620.0 MHz)	3	23.0	13.5	12.5	11.5
8	5G NR	N41 (2496.0 – 2690.0 MHz)	3	23.0	13.0	12.0	11.0	
8	5G NR	N41 (2496.0 – 2690.0 MHz)	2	27.0	13.0	12.0	11.0	
8	5G NR	N66 (1710.0 – 1780.0 MHz)	3	23.0	18.0	17.0	16.0	
8	5G NR	N77 (3700.0 – 3980.0 MHz)	3	23.0	14.0	13.0	12.0	
8	5G NR	N77 (3700.0 – 3980.0 MHz)	2	27.0	14.0	13.0	12.0	
8	5G NR	N78 (3700.0 – 3800.0 MHz)	3	23.0	14.5	13.5	12.5	
8	5G NR	N78 (3700.0 – 3800.0 MHz)	3	27.0	14.5	13.5	12.5	

SAR compliance is demonstrated with the Reported SAR: $Reported\ SAR = measured\ 1gSAR\ @\ Reported\ Upper\ Threshold < FCC\ SAR\ limit$ where, $Reported\ Upper\ Threshold = Upper\ Threshold\ (stored\ in\ NVM) + Tolerance$

7. Remarks and comments

- Only the plots for the test positions with the highest measured SAR per band/mode are included in Annex C as required per FCC OET KDB 865664 D02, paragraph 2.3.h.
- Maximum transmission power on modulations 64QAM and 256QAM for LTE and 5G NR, are lower than other modulations QPSK and 16QAM. Therefore, according to engineering evaluation, we choose higher power modulations to perform all tests shown in the report

8. Test Verdicts summary

The statement of conformity to applicable standards in the table below are based on the measured values, without taking into account the measurement uncertainties.

Mode	Band (UL)	Highest Reported SAR (1g) (W/kg)	Verdict
WCDMA	FDD II (1850.0 – 1910.0 MHz)	0.97	P
	FDD IV (1710.0 – 1755.0 MHz)	0.94	P
	FDD V (824.0 – 849.0 MHz)	0.95	P
LTE FDD	Band 2 (1850.0 – 1910.0 MHz)	NM	NA
	Band 4 (1710.0 – 1755.0 MHz)	NM	NA
	Band 5 (824.0 – 849.0 MHz)	1.16	P
	Band 7 (2500.0 – 2570.0 MHz)	1.41	P
	Band 12 (699.0 – 716.0 MHz)	1.10	P
	Band 13 (777.0 – 787.0 MHz)	1.23	P
	Band 14 (788.0 – 798.0 MHz)	1.22	P
	Band 17 (704.0 – 716.0 MHz)	NM	NA
	Band 25 (1850.0 – 1915.0 MHz)	1.09	P
	Band 26 (814.0 – 849.0 MHz)	0.79	P
	Band 30 (2305.0 – 2315.0 MHz)	1.04	P
	Band 66 (1710.0 – 1780.0 MHz)	0.94	P
	LTE TDD	Band 38 (2570.0 – 2620.0 MHz)	NM
Band 41 (2496.0 – 2690.0 MHz)		0.77	P
Band 48 (3550.0 – 3700.0 MHz)		0.36	P
5G NR FR1 FDD	Band 2 (1850.0 – 1910.0 MHz)	1.04	P
	Band 5 (824.0 – 849.0 MHz)	1.13	P
	Band 7 (2500.0 – 2570.0 MHz)	1.32	P
	Band 25 (1850.0 – 1915.0 MHz)	1.19	P
	Band 30 (2305.0 – 2315.0 MHz)	1.01	P
	Band 66 (1710.0 – 1780.0 MHz)	1.05	P
5G NR FR1 TDD	Band 38 (2570.0 – 2620.0 MHz)	1.13	P
	Band 41 (2496.0 – 2690.0 MHz)	1.18	P
	Band 77 (3700.0 – 3980.0 MHz)	0.32	P
	Band 78 (3700.0 – 3800.0 MHz)	0.47	P

P: Pass

F: Fail

NM: Not Measured

NA: Not Applicable

According to the FCC OET KDB 690783 D01, this is the summary of the values for the Grant Listing:

Highest Reported SAR (1g) (W/kg)				
Exposure Condition	Equipment Class			
	PCE	DTS	DSS	U-NII
Body Worn	1.41	1.17	0.40	0.92
Simultaneous Tx	Sum-SAR: 3.86 SPLSR: 0.04	Sum-SAR: 3.15 SPLSR: 0.04	Sum-SAR: 3.86 SPLSR: 0.03	Sum-SAR: 3.86 SPLSR: 0.03

Considering the results of the performed test according to FCC 47CFR Part 2.1093 the item under test is IN COMPLIANCE with the requested specifications specified in Section1. Standards, reference documents and applicable test methods

9. Document Revision History

Revision #	Modified by	Revision Details
Rev. 00	E. Garcia; A.Lounes	First Issue

Annex A. Test & System Description

A.1 SAR Definition

Specific Absorption rate is defined as the time derivative of the incremental energy (dW) absorbed by (dissipated in) and incremental mass (dm) contained in a volume element (dV) of a given density (ρ).

$$SAR = \frac{d}{dt} \cdot \left(\frac{dW}{dm} \right) = \frac{d}{dt} \cdot \left(\frac{dW}{\rho \cdot dV} \right)$$

SAR is expressed in units of watts per kilogram (W/kg). SAR can be related to the electric field at a point by

$$SAR = \frac{\sigma |E|^2}{\rho}$$

Where:

σ = Conductivity of the tissue (S/m)
 ρ = Mass density of the tissue (kg/m³)
E = RMS electric field strength (V/m)

A.2 SAR Measurement System

A.2.1 SAR Measurement Setup

The DASY6 system for performing compliance tests consists of the following items:

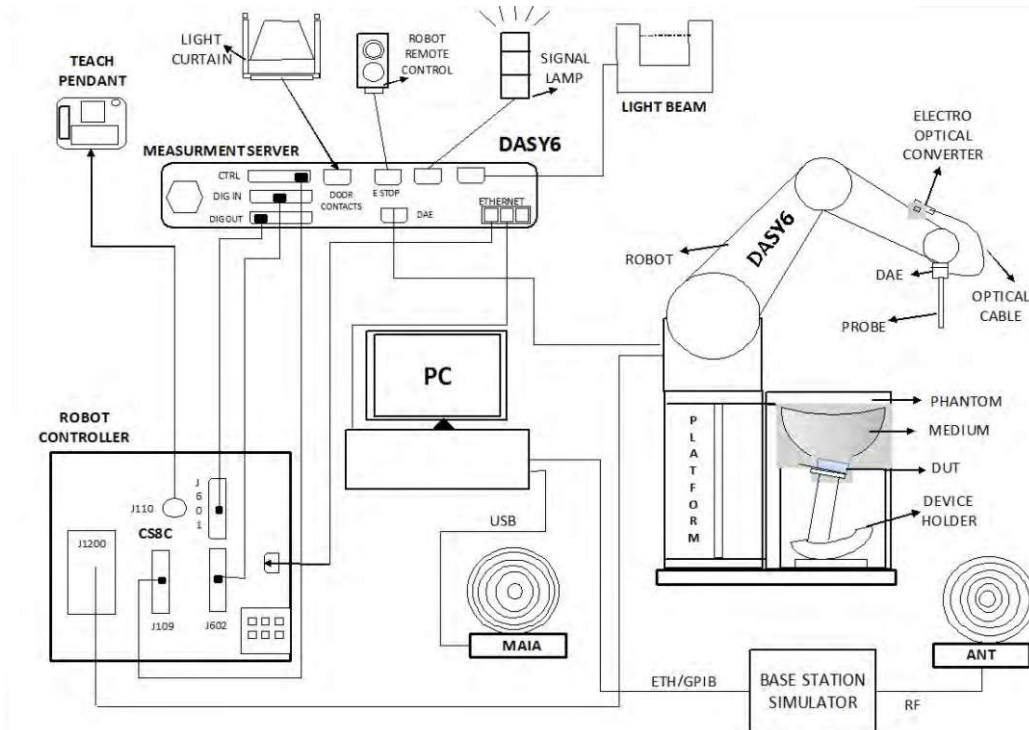

- ✓ A standard high precision 6-axis robot (Stäubli TX/RX family) with controller, teach pendant and software. It includes an arm extension for accommodating the data acquisition electronics (DAE)
- ✓ An isotropic field probe optimized and calibrated for the targeted measurements.
- ✓ A data acquisition electronics (DAE) which performs the signal amplification, signal multiplexing, AD-conversion, offset measurements, mechanical surface detection, collision detection, etc. The unit is battery powered with standard or rechargeable batteries. The signal is optically transmitted to the EOC.
- ✓ The Electro-optical Converter (EOC) performs the conversion from optical to electrical signals for the digital communication to the DAE. The EOC signal is transmitted to the measurement server.
- ✓ The function of the measurement server is to perform the time critical tasks such as signal filtering, control of the robot operation and fast movements interrupts.
- ✓ The Light Beam used is for probe alignment. This improves the (absolute) accuracy of the probe positioning.
- ✓ A computer running Win7 professional operating system and the DASY6 software.
- ✓ Remote control and teach pendant as well as additional circuitry for robot safety such as warning lamps, etc.
- ✓ The phantom, the device holder and other accessories according to the targeted measurement.
- ✓ MAIA is a hardware interface (Antenna) used to evaluate the modulation and audio interference characteristics of RF signals.
- ✓ ANT is an ultra-wideband antenna for use with the base station simulators over 698 MHz to 6GHz.
- ✓ The base station simulator is an equipment used for SAR cellular tests in order to emulate the cellular signals characteristics and behavior between a regular base station and the equipment under test.
- ✓ Tissue simulating liquid.
- ✓ System Validation dipoles.
- ✓ Network emulator.

A.2.2 E-Field Measurement Probe

The probe is constructed using three orthogonal dipole sensors arranged on an interlocking, triangular prism core. The probe has built-in shielding against static charges and is contained within a PEEK cylindrical enclosure material at the tip.



The probe's characteristics are:

Frequency Range	30MHz – 6GHz
Length	337 mm
Probe tip external diameter	2.5 mm
Typical distance between dipoles and the probe tip	1 mm
Axial Isotropy (in human-equivalent liquids)	±0.3 dB
Hemispherical Isotropy (in human-equivalent liquids)	±0.5 dB
Linearity	±0.2 dB
Maximum operating SAR	100 W/kg
Lower SAR detection threshold	0.001 W/kg

A.2.3 SAM Phantom

The shell corresponds to the specifications of the Specific Anthropomorphic Mannequin (SAM) phantom defined in IEEE 1528 and IEC 62209-1. It enables the dosimetric evaluation of left and right hand phone usage as well as body mounted usage at the flat phantom region. A cover prevents evaporation of the liquid. Reference markings on the phantom allow the complete setup of all predefined phantom positions and measurement grids by teaching three points with the robot.

The phantom's characteristics are:

Material	Vinylester, glass fiber reinforced (VE-GF)
Shell thickness	2 mm ± 0.2 mm
Shell thickness at ERP	6 ± 0.2 mm
Filling volume	25 Liters
Dimensions	Length: 1000mm / Width: 500mm

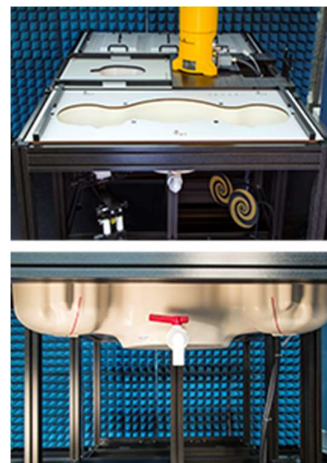

A.2.4 Flat Phantom

Phantom for compliance testing of handheld and body-mounted wireless devices in the frequency range of 30 MHz to 6 GHz. ELI is fully compatible with the IEC 62209-2 standard and all known tissue simulating liquids. ELI has been optimized regarding its performance and can be integrated into our standard phantom tables. A cover prevents evaporation of the liquid. Reference markings on the phantom allow installation of the complete setup, including all predefined phantom positions and measurement grids, by teaching three points. The phantom is compatible with all SPEAG dosimetric probes and dipoles.

The phantom's characteristics are:

Material	Vinylester, glass fiber reinforced (VE-GF)
Shell thickness	2 mm ± 0.2 mm
Filling volume	30 Liters approx.
Dimensions	Major axis: 600mm / Minor axis: 400mm

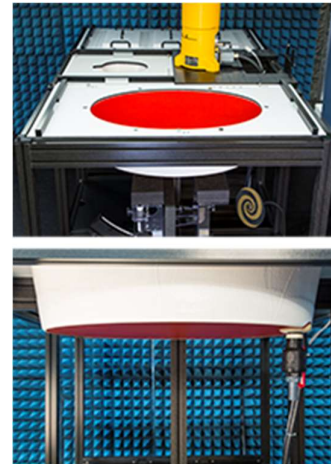

A.2.5 Device Positioner

The SAR in the phantom is approximately inversely proportional to the square of the distance between the source and the liquid surface. For a source at 5 mm distance, a positioning uncertainty of 0.5 mm would produce a SAR uncertainty of 20%. Accurate device positioning is therefore crucial for accurate and repeatable measurements. The positions in which the devices must be measured are defined by the standards.

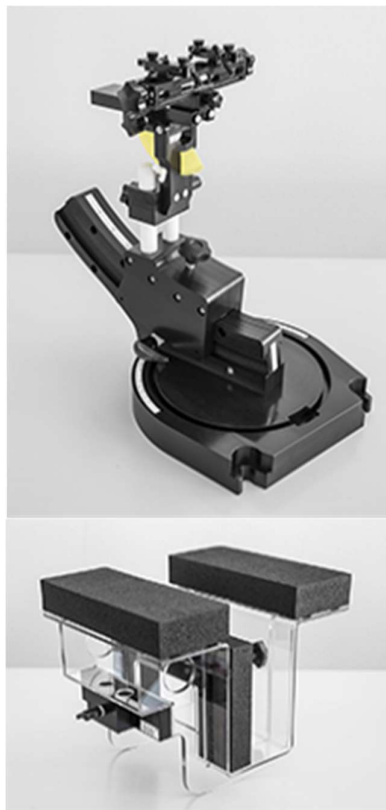

The DASY device holder is designed to cope with the different positions given in the standard. It has two scales for device rotation (with respect to the body axis) and device inclination (with respect to the line between the ear reference points). The rotation center for both scales is the ear reference point (ERP). Thus the device needs no repositioning when changing the angles.

The DASY device holder is constructed of low-loss POM material having the following dielectric parameters: relative permittivity $\epsilon=3$ and loss tangent $\delta=0.02$. The amount of dielectric material has been reduced in the closest vicinity of the device, since measurements have suggested that the influence of the clamp on the test results could thus be lowered.

A simple but effective and easy-to-use extension for the Mounting Device; facilitates testing of larger devices according to IEC 62209-2 (e.g., laptops, cameras, etc.); lightweight and fits easily on the upper part of the Mounting Device in place of the phone positioner. The extension is fully compatible with the Twin SAM, ELI and other Flat Phantoms.

A.3 Data Evaluation

- **Power Reference measurement**

The robot measures the E field in a specified reference position that can be either the selected section's grid reference point or a user point in this section at 4mm of the inner surface of the phantom, 2mm for frequencies above 3GHz.

- **Area Scan**

Measurement procedures for evaluating SAR from wireless handsets typically start with a coarse measurement grid to determine the approximate location of the local peak SAR values. This is known as the area-scan procedure. The SAR distribution is scanned along the inside surface of one side of the phantom head, at least for an area larger than the projection of the handset and antenna. The distance between the measured points and phantom surface should be less than 8 mm, and should remain constant (with variation less than ± 1 mm) during the entire scan in order to determine the locations of the local peak SAR with sufficient accuracy. The angle between the probe axis and the surface normal line is recommended but not required to be less than 30° . If this angle is larger than 30° and the closest point on the probe-tip housing to the phantom surface is closer than a probe diameter, the boundary effect may become larger and polarization dependent. This additional uncertainty needs to be analyzed and accounted for. To achieve this, modified test procedures and additional uncertainty analyses not described in this recommended practice may be required. The measurement and interpolation point spacing should be chosen such as to allow identification of the local peak locations to within one-half of the linear dimension of a side of the zoom-scan volume. Because a local peak having specific amplitude and steep gradients may produce a lower peak spatial-average SAR compared to peaks with slightly lower amplitude and less steep gradients, it is necessary to evaluate these other peaks as well. However, since the spatial gradients of local SAR peaks are a function of the wavelength inside the tissue-equivalent liquid and the incident magnetic field strength, it is not necessary to evaluate local peaks that are less than 2 dB or more below the global maximum peak. Two-dimensional spline algorithms (Brishoual et al. 2001; Press et al., 1996) are typically used to determine the peaks and gradients within the scanned area. If a peak is found at a distance from the scan border of less than one-half the edge dimension of the desired 1 g or 10 g cube, the measurement area should be enlarged if possible.

- **Zoom Scan**

To evaluate the peak spatial-average SAR values for 1 g or 10 g cubes, fine resolution volume scans, called zoom scans, are performed at the peak SAR locations identified during the area scan. The minimum zoom scan volume size should extend at least 1.5 times the edge dimension of a 1 g cube in all directions from the center of the scan volume, for both 1 g and 10 g peak spatial-average SAR evaluations. Along the phantom curved surfaces, the front face of the volume facing the tissue/liquid interface conforms to the curved boundary, to ensure that all SAR peaks are captured. The back face should be equally distorted to maintain the correct averaging mass. The flatness and orientation of the four side faces are unchanged from that of a cube whose orientation is within $\pm 30^\circ$ of the line normal to the phantom at the center of the cube face next to the phantom surface. The peak local SAR locations that were determined in the area scan (interpolated values) should be used for the centers of the zoom scans. If a scan volume cannot be centered due to proximity of a phantom shape feature, the probe should be tilted to allow scan volume enlargement. If probe tilt is not feasible, the zoom-scan origin may be shifted, but not by more than half of the 1 g or 10 g cube edge dimension.

After the zoom-scan measurement, extrapolations from the closest measured points to the surface, for example along lines parallel to the zoom-scan centerline, and interpolations to a finer resolution between all measured and extrapolated points are performed. Extrapolation algorithm considerations are described in 6.5.3, and 3-D spline methods (Brishoual et al., 2001; Kreyszig, 1983; Press et al., 1996) can be used for interpolation. The peak spatial-average SAR is finally determined by a numerical averaging of the local SAR values in the interpolation grid, using for example a trapezoidal algorithm for the integration (averaging).

In some areas of the phantom, such as the jaw and upper head regions, the angle of the probe with respect to the line normal to the surface may be relatively large, e.g., greater than $\pm 30^\circ$, which could increase the boundary effect error to a larger level. In these cases, during the zoom scan a change in the orientation of the probe, the phantom, or both is recommended but not required for the duration of the zoom scan, so that the angle between the probe axis and the line normal to the surface is within 30° for all measurement points.

- **Power Drift measurement**

The robot re-measures the E-Field in the same reference location measured at the Power Reference. The drift measurement gives the field difference in dB from the first to the last reference reading. This allows a user to monitor the power drift of the device under test that must remain within a maximum variation of $\pm 5\%$.

- **Post-processing**

The procedure for spatial peak SAR evaluation has been implemented according to the IEEE1528 and IEC 62209-1/2 standards. It can be conducted for 1g and 10g.

The software allows evaluations that combine measured data and robot positions, such as:

- ✓ Maximum search
- ✓ Extrapolation
- ✓ Boundary correction
- ✓ Peak search for averaged SAR

Interpolation between the measured points is performed when the resolution of the grid is not fine enough to compute the average SAR over a given mass.

Extrapolation routines are used to obtain SAR values between the lowest measurement points and the inner phantom surface. The extrapolation is determined by the surface detection distance and the probe sensor offset. Several measurements at different distances are necessary for the extrapolation.

A.4 System and Liquid Check

A.4.1 System Check

The system performance check verifies that the system operates within its specifications. System and operator errors can be detected and corrected. It is recommended that the system performance check be performed prior to any usage of the system in order to guarantee reproducible results.

The system performance check uses normal SAR measurements in a simplified setup with a well characterized source. This setup was selected to give a high sensitivity to all parameters that might fail or vary over time. The system check does not intend to replace the calibration of the components, but indicates situations where the system uncertainty is exceeded due to drift or failure.

In the simplified setup for system check, the EUT is replaced by a calibrated dipole and the power source is replaced by a controlled continuous wave generated by a signal generator. The calibrated dipole must be placed beneath the flat phantom section of the phantom at the correct distance.

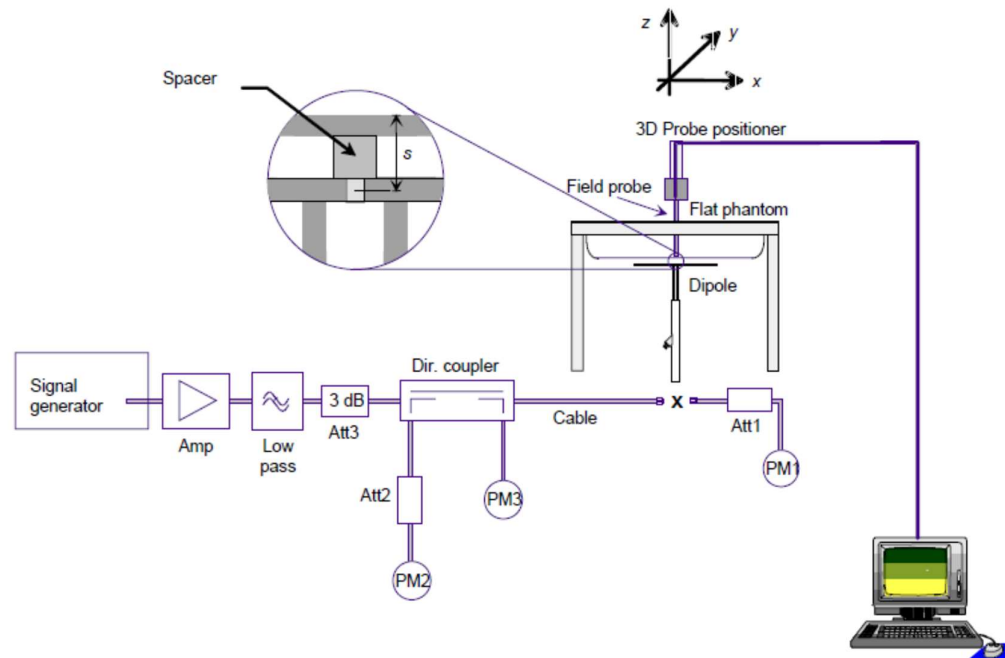

The equipment setup is shown below:

- ✓ Signal Generator
- ✓ Amplifier
- ✓ Directional coupler
- ✓ Power meter
- ✓ Calibrated dipole

First, the power meter PM1 (including attenuator Att1) is connected to the cable to measure the forward power at the location of the connector (x) to the system check source. The signal generator is adjusted for the desired forward power at the connector as read by power meter PM1 after attenuation Att1 and also as coupled through Att2 to PM2. After connecting the cable to the source, the signal generator is readjusted for the same reading at power meter PM2.

SAR results are normalized to a forward power of 1W to compare the values with the calibration reports results as described at IEEE 1528 and IEC 62209 standards.

A.4.2 Liquid Check

The dielectric parameters check is done prior to the use of the tissue simulating liquid. The verification is made by comparing the relative permittivity and conductivity to the values recommended by the applicable standards.

The liquid verification was performed using the following test setup:

- ✓ VNA (Vector Network Analyzer)
- ✓ Open-Short-Load calibration kit
- ✓ RF Cable
- ✓ Open-Ended Coaxial probe
- ✓ DAK software tool
- ✓ SAR Liquid
- ✓ De-ionized water
- ✓ Thermometer

These are the target dielectric properties of the tissue-equivalent liquid material as defined in FCC OET KDB 865664 D01.

Frequency (MHz)	Body SAR	
	ϵ_r (F/m)	σ (S/m)
150	61.9	0.80
300	58.2	0.92
450	56.7	0.94
835	55.2	0.97
900	55.0	1.05
1450	54.0	1.30
1800-2000	53.3	1.52
2450	52.7	1.95
3000	52.0	2.73
5800	48.2	6.00

(ϵ_r = relative permittivity, σ = conductivity and ρ = 1000 kg/m³)

The measurement system implement a SAR error compensation algorithm as documented in IEEE Std 1528-2013 (equivalent to draft standard IEEE P1528-2011) to automatically compensate the measured SAR results for deviations between the measured and required tissue dielectric parameters (applied to only scale up the measured SAR, and not downward) so, according to FCC OET KDB 865664 D01, the tolerance for ϵ_r and σ may be relaxed to $\pm 10\%$.

A.5 Test Equipment List

A.5.1 SAR System #2

The system 2 was used for WCDMA and LTE tests.

ID #	Device	Type/Model	Serial Number	Manufacturer	Cal. Date	Cal. Due Date
002-008	Data Acquisition Electronics	DAE4	1429	SPEAG	2021-05-11	2022-05-11
002-009	Dosimetric E-Field probe	EX3DV4	3978	SPEAG	2021-05-22	2022-05-22
002-000	6-axis Robot	TX60 L	F16/55FXA1/A/01	STAÜBLI	n/a	n/a
002-001	Robot Controller	CS8C	F16/55FXA1/C/01	STAÜBLI	n/a	n/a
002-002	Measurement Server	DASY6 P/N: SE UMS 028 BB	1489	SPEAG	n/a	n/a
002-003	Electro-Optical Converter	EOC60	1098	SPEAG	n/a	n/a
002-004	Light Beam Unit	SE UKS 030 AA	-	Di-soric	n/a	n/a
002-005	Oval Flat Phantom	ELI v8.0	2048	SPEAG	n/a	n/a
002-007	Measurement SW	DASY v6.14	9-5DEE27C2	SPEAG	n/a	n/a
002-006	Laptop Holder	P/N SM LH1 001 CD	-	SPEAG	n/a	n/a

A.5.2 SAR System #4

The system 4 was used for 5G NR tests.

ID #	Device	Type/Model	Serial Number	Manufacturer	Cal. Date	Cal. Due Date
002-008	Data Acquisition Electronics	DAE4	1628	SPEAG	2021-05-11	2022-05-11
002-009	Dosimetric E-Field probe	EX3DV4	7604	SPEAG	2021-05-22	2022-05-22
085-000	Data Acquisition Electronics	DAE4	1517	SPEAG	2021-03-11	2022-03-11
086-000	Dosimetric E-Field probe	EX3DV4	7455	SPEAG	2021-03-20	2022-03-20
004-000	6-axis Robot	TX90 XL	F11/5JL2A1/A/01	STAÜBLI	n/a	n/a
004-001	Robot Controller	CS8C	F11/5JL2A1/C/01	STAÜBLI	n/a	n/a
004-005	Measurement Server	DASY6 P/N: SE UMS 028 BB	-	SPEAG	n/a	n/a
004-004	Light Beam Unit	SE UKS 030 AA	1030	Di-soric	n/a	n/a
004-002	OvalFlat Phantom	ELI v8.0	2124	SPEAG	n/a	n/a
004-005	Measurement SW	DASY6 16.0	9-658E90FA	SPEAG	n/a	n/a
004-010	Laptop Holder	P/N SM LH1 001 CD	-	SPEAG	n/a	n/a
458-000	Automation SW	SARA v2.2	-	Intel	n/a	n/a

A.5.3 Shared Instrumentation

ID #	Device	Type/Model	Serial Number	Manufacturer	Cal. Date	Cal. Due Date
123-000	USB Power Sensor	NRP-Z81	102278	R&S	2021-04-13	2023-04-13
124-000	USB Power Sensor	NRP-Z81	102279	R&S	2021-04-13	2023-04-13
135-000	Network Emulator	CMW500	152721	R&S	2020-03-26	2022-03-26
023-000	5G Network Emulator	CMX500	101444	R&S	2020-08-24	2022-08-24
126-000	Vector Signal Generator	ESG E4438C	MY45092885	Agilent	2021-05-27	2023-05-27
099-000	Liquid measurement SW	DAK-3.5 V2.6.0.5	9-2687B491	SPEAG	n/a	n/a
339-000	Vector Network Analyzer	ZNB 40	101740	R&S	2020-07-10	2022-07-10
071-000	750 MHz System Validation Dipole	D750V3	1136	SPEAG	2021-01-21	2023-01-21
072-000	835 MHz System Validation Dipole	D835V2	4d192	SPEAG	2021-01-21	2023-01-21
073-000	1750 MHz System Validation Dipole	D1750V2	1133	SPEAG	2021-01-14	2023-01-14
074-000	1900 MHz System Validation Dipole	D1900V2	5d197	SPEAG	2021-01-14	2023-01-14
075-000	2300 MHz System Validation Dipole	D2300V2	1046	SPEAG	2021-01-13	2023-01-13
076-000	2600 MHz System Validation Dipole	D2600V2	1100	SPEAG	2021-01-13	2023-01-13
404-000	3700 MHz System Validation Dipole	D3700V2	1093	SPEAG	2021-05-21	2023-05-21
327-000	Temperature & Humidity Logger	RA32E-TH1-RAS	RA32-F0DED9	AVTECH	2021-03-09	2023-03-09
095-000*	Thermometer	925	34822881	Testo	2019-11-19	2021-11-19
398-000	Thermometer	922	33622932/208	Testo	2021-11-09	2023-11-19
198-000	0.8-21GHz RF amplifier	TVA-82-213A	2004003	Mini-Circuits	2021-08-13	2022-02-13
078-000	RF Cable	ST-18/SMAm/SMAm/48	1158830	Huber & Suhner	2021-08-13	2022-02-13
079-000	RF Cable	ST-18/SMAm/SMAm/48	1158831	Huber & Suhner	2021-08-13	2022-02-13
077-000	Coupler	CD0.5-8-20-30	1251-002	Amd-group	2021-08-13	2022-02-13

*Equipment used only during the calibration period

A.5.4 Tissue Simulant Liquid

TSL	Manufacturer / Model	Freq Range (MHz)	Main Ingredients	Note
Body WideBand System2	SPEAG MBBL600-6000V6 Batch 160603-01	600-6000	Ethenediol, Sodium petroleum sulfonate, Hexylene Glycol / 2-Methyl-pentane-2.4-diol, Alkoxylated alcohol	Used for WCDMA and LTE tests
Body WideBand System 4	SPEAG MBBL600-6000V6 Batch 160630-01	600-6000	Ethenediol, Sodium petroleum sulfonate, Hexylene Glycol / 2-Methyl-pentane-2.4-diol, Alkoxylated alcohol	Used for 5G NR tests

A.6 Measurement Uncertainty Evaluation

The system uncertainty evaluation is shown in the table below with a coverage factor of $k = 2$ to indicate a 95% level of confidence:

SPEAG DASY6 Uncertainty Budget According to IEC/IEEE 62209-1528 (4 MHz - 6 GHz) including IEEE 1528-2013 and IEC 62209-1/2016, IEC 62209-2/2010								
Symbol	Error Description	Uncert. Value	Prob. Dist.	Div.	(ci) 1g	(ci) 10g	Std Unc. (1g)	Std Unc. (10g)
Measurement System Errors								
CF	<i>Probe Calibration</i>	±14.0 %	N	2	1	1	±7.0 %	±7.0 %
CF _{drift}	Probe Calibration Drift	±1.0 %	N	1	1	1	±1.0 %	±1.0 %
LIN	Probe Linearity	±4.7 %	R	√3	1	1	±2.7 %	±2.7 %
BBS	Broadband Signal	±3.0 %	N	2	1	1	±1.5 %	±1.5 %
ISO	<i>Axial Isotropy</i>	±4.7 %	R	√3	0.5	0.5	±1.4 %	±1.4 %
ISO	Hemispherical Isotropy	±9.6 %	R	√3	0.5	0.5	±2.8 %	±2.8 %
DAE	Data Acquisition	±0.3 %	N	1	1	1	±0.3 %	±0.3 %
AMB	RF Ambient	±1.8 %	N	1	1	1	±1.8 %	±1.8 %
Δ _{sys}	Probe Positioning	±0.2 %	N	1	0.33	0.33	±0.1 %	±0.1 %
DAT	Data Processing	±2.3 %	N	1	1	1	±2.3 %	±2.3 %
Phantom and Device Errors								
LIQ(σ)	Conductivity (meas.) _{DAK}	±2.5 %	N	1	0.78	0.71	±2.0 %	±1.8 %
LIQ(Tσ)	Conductivity (temp.) _{BB}	±3.4 %	R	√3	0.78	0.71	±1.5 %	±1.4 %
EPS	Phantom Permittivity	±14.0 %	R	√3	0.25	0.25	±2.0 %	±2.0 %
DAS	Distance DUT - TSL	±2.0 %	N	1	2	2	±4.0 %	±4.0 %
H	Device Holder	±3.6 %	N	1	1	1	±3.6 %	±3.6 %
MOD	DUT Modulation _m	±2.4 %	R	√3	1	1	±1.4 %	±1.4 %
TAS	Time-average SAR	±2.6 %	R	√3	1	1	±1.5 %	±1.5 %
RF _{drift}	DUT drift	±5.0 %	N	1	1	1	±2.9 %	±2.9 %
Correction to the SAR results								
C(ε, σ)	Deviation to Target	±1.9 %	N	1	1	0.84	±1.9 %	±1.6 %
Combined Std. Uncertainty							±11.5 %	±11.4 %
Expanded STD Uncertainty							±23.1 %	±22.9 %

A.7 RF Exposure Limits

SAR assessments have been made in line with the requirements of FCC 47 CFR Part 2.1093 on the limitation of exposure of the general population / uncontrolled exposure for portable devices.

Exposure Type	General Population / Uncontrolled Environment
Peak spatial-average SAR (averaged over any 1 gram of tissue)	1.6 W/kg
Whole body average SAR	0.08 W/kg
Peak spatial-average SAR (extremities) (averaged over any 10 grams of tissue)	4.0 W/kg

Annex B. Test Results

The herein test results were performed by:

Test case measurement	Test Personnel
SAR measurement	E. Garcia, R. Luciani
Conducted measurement	F. Heurtematte

B.1 Test Conditions

B.1.1 Test SAR Test positions relative to the phantom

The device under test was a Convertible PC, FM350-GL. The device was operated utilizing proprietary software, and each channel was measured using a communication tester to determine the maximum average power.

The device has 2 power settings:

- Notebook mode
- Tablet mode

See section 6 for details about power values for the configuration

See Annex F.3 for information about the platform antenna configuration

In the same manner the required test positions analysis is done considering the two possible user configurations and power levels for each one

Notebook mode

The highest tune up power for this mode is 27dBm in LTE41 PC2. Notebook mode can be reduced given the distance of the antenna to the measurement point and the above maximum power. For more details refer to section B.1.3.1

Tablet mode

According to FCC OET KDB 616217 D04, the back surface and edges of the tablet should be tested for SAR compliance with the tablet touching the phantom. The SAR Test Exclusion Threshold in FCC OET KDB 447498 D01 can be applied to determine SAR test exclusion for adjacent edge configurations. (See section 6 for power specifications)

The reduced power values shown on section 6 and the closest distance from the antenna to an adjacent tablet edge is used to determine if SAR testing is required for the adjacent edges, with the adjacent edge positioned against the phantom and the edge containing the antenna positioned perpendicular to the phantom.

Considering the antenna location diagrams in Annex F and the test exclusions described before, the surfaces/edges to be measured for each antenna are:

Tablet	WWAN Main 5	WWAN Aux 8
Position	<ul style="list-style-type: none"> • Top Edge • Back Face • Right Edge 	<ul style="list-style-type: none"> • Top Edge • Back Face

See B.1.3.1 for a more detailed list of the applied reductions.

See F.2 *Test position* section for more information on the tested positions.

B.1.2 Test signal, Output power and Test Frequencies

B.1.2.1 LTE TDD consideration

According to KDB 941225 D05 SAR for LTE Devices, for Time-Division Duplex (TDD) systems, SAR must be tested using a fixed periodic duty factor according to the highest transmission duty factor implemented for the device and supported by the defined 3GPP LTE TDD configurations.

LTE TDD Bands support 3GPP TS 36.211 section 4.2 for Type 2 Frame structure and table 2 for uplink-downlink configurations and table 1 for special subframe configurations

Table 1

Special subframe configuration	Normal cyclic prefix in downlink			Extended cyclic prefix in downlink		
	DwPTS	UpPTS		DwPTS	UpPTS	
		Normal cyclic prefix in uplink	Extended cyclic prefix in uplink		Normal cyclic prefix in uplink	Extended cyclic prefix in uplink
0	6592 T _s	(1+X) 2192 T _s	(1+X) 2560 T _s	7680 · T _s	(1+X) 2192 T _s	(1+X) 2560 T _s
1	19760 T _s			20480 T _s		
2	21952 T _s			23040 T _s		
3	24144 T _s			25600 T _s		
4	26336 T _s			7680 T _s		
5	6592 T _s	(2+X) 2192 T _s	(2+X) 2560 T _s	20480 T _s	(2+X) 2192 T _s	(2+X) 2560 T _s
6	19760 T _s			23040 T _s		
7	21952 T _s			12800 T _s		
8	24144 T _s			-		
9	13168 T _s			-		
10	13168 T _s	13150 T _s	12800 T _s	-	-	-

Table2

Uplink-Downlink Config.	Downlink-to-Uplink Switch-point Periodicity	Subframe Number										Calculated Duty Cycle (%)
		0	1	2	3	4	5	6	7	8	9	
0	5 ms	D	S	U	U	U	D	S	U	U	U	63.3%
1	5 ms	D	S	U	U	D	D	S	U	U	D	43.3%
2	5 ms	D	S	U	D	D	D	S	U	D	D	23.3%
3	10 ms	D	S	U	U	U	D	D	D	D	D	31.7%
4	10 ms	D	S	U	U	D	D	D	D	D	D	21.7%
5	10 ms	D	S	U	D	D	D	D	D	D	D	11.7%
6	5 ms	D	S	U	U	U	D	S	U	U	D	53.3%

Calculated duty cycle = Extended cyclic prefix in uplink *(TS)# of S + # of U / period
The configuration used for SAR testing was the number 0 which corresponds to the highest duty cycle (Power Class 3)

Frame structure and maximal measured duty cycle for NR 5G FR1 are described in the table 3.

B.1.2.2 5G NR TDD consideration

Table3

Subframe Number																			
Radio Frame 0																			
SF0	SF1	SF2	SF3	SF4	SF5	SF6	SF7	SF8	SF9	SF0	SF1	SF2	SF3	SF4	SF5	SF6	SF7	SF8	SF9
0	1	2	3	4	5	6	7	8	9	0	1	2	3	4	5	6	7	8	9
D	s	U	U	S	U	S	U	S	U	S	U	S	U	S	U	S	U	S	U
Radio Frame 1-2																			
SF0	SF1	SF2	SF3	SF4	SF5	SF6	SF7	SF8	SF9	SF0	SF1	SF2	SF3	SF4	SF5	SF6	SF7	SF8	SF9
0	1	2	3	4	5	6	7	8	9	0	1	2	3	4	5	6	7	8	9
S	U	S	U	S	U	S	U	S	U	S	U	S	U	S	U	S	U	S	U
Radio Frame 3																			
SF0	SF1	SF2	SF3	SF4	SF5	SF6	SF7	SF8	SF9	SF0	SF1	SF2	SF3	SF4	SF5	SF6	SF7	SF8	SF9
0	1	2	3	4	5	6	7	8	9	0	1	2	3	4	5	6	7	8	9
S	U	S	U	S	U	S	U	S	U	S	U	S	U	S	U	S	U	S	U

“D”: Full DL slot, “s”: partial slot, “S”: partial slot for PUSCH, “U”: full UL slot

B.1.3 Evaluation Exclusion and Test Reductions

B.1.3.1 SAR evaluation exclusion

The SAR Test Exclusion Threshold in FCC OET KDB 447498 D01 v06 can be applied to determine SAR test exclusion for adjacent edge configurations. For 100MHz to 6GHz and test separation distances ≤50mm, the 1-g and 10-g SAR test exclusion thresholds are determined by the following formula:

$$[(\text{max. power of channel, including tune – up tolerance, mW}) / (\text{min. test separation distance, mm})] \cdot \sqrt{f(\text{GHz})} \leq 3.0 \text{ for } 1g \text{ SAR, and } \leq 7.5 \text{ for } 10g \text{ extremity SAR} \tag{1}$$

Where:

- f(GHz) is the RF channel transmit frequency in GHz
- Power and distance are rounded to the nearest mW and mm before calculation
- The result is rounded to one decimal place for comparison
- The values 3.0 and 7.5 are referred to as numeric thresholds

The test exclusions are applicable only when the minimum test separation distance is ≤ 50 mm, and for transmission frequencies between 100 MHz and 6 GHz. When the minimum test separation distance is < 5 mm, a distance of 5 mm is applied to determine SAR test exclusion.

For test separation distances > 50 mm, the 1-g and 10-g SAR test exclusion thresholds are determined using the following formulas:

$$((\text{Power allowed at numeric threshold for } 50 \text{ mm in (1)}) + (\text{test separation distance} - 50 \text{ mm}) \cdot (f_{\text{MHz}}/150))\text{mW, for } 100\text{MHz to } 1500\text{MHz} \tag{2}$$

$$((\text{Power allowed at numeric threshold for } 50 \text{ mm in (1)}) + (\text{test separation distance} - 50 \text{ mm}) \cdot 10)\text{mW, for } 1500\text{MHz and } \leq 6\text{GHz} \tag{3}$$

Test Exclusion

Antenna	Band Name	Output power		Laptop	Back Face	Top Edge	Bottom Edge	Left Edge	Right Edge	Laptop	Back Face	Top Edge	Bottom Edge	Left Edge	Right Edge
		dBm	mW												
WWAN (Main Ant5)	FDD II	16.5	44.7	>50	<50	<50	>50	>50	<50	R	T	T	R	R	T
	FDD IV	19.0	79.4	>50	<50	<50	>50	>50	<50	R	T	T	R	R	T
	FDD V	20.5	112.2	>50	<50	<50	>50	>50	<50	R	T	T	R	R	T
	LTE 2	16.5	44.7	>50	<50	<50	>50	>50	<50	R	R	R	R	R	R
	LTE 4	19.0	79.4	>50	<50	<50	>50	>50	<50	R	R	R	R	R	R
	LTE 5	20.5	112.2	>50	<50	<50	>50	>50	<50	R	T	T	R	R	T
	LTE 7	14.0	25.1	>50	<50	<50	>50	>50	<50	R	T	T	R	R	T
	LTE 12	19.5	89.1	>50	<50	<50	>50	>50	<50	R	T	T	R	R	T
	LTE 13	19.5	89.1	>50	<50	<50	>50	>50	<50	R	T	T	R	R	T
	LTE 14	19.5	89.1	>50	<50	<50	>50	>50	<50	R	T	T	R	R	T
	LTE 17	19.5	89.1	>50	<50	<50	>50	>50	<50	R	R	R	R	R	R
	LTE 25	16.5	44.7	>50	<50	<50	>50	>50	<50	R	T	T	R	R	T
	LTE 26	20.0	100.0	>50	<50	<50	>50	>50	<50	R	T	T	R	R	T
	LTE 30	17.0	56.2	>50	<50	<50	>50	>50	<50	R	T	T	R	R	T
	LTE 38	15.0	31.6	>50	<50	<50	>50	>50	<50	R	R	R	R	R	R
	LTE 41	15.0	31.6	>50	<50	<50	>50	>50	<50	R	T	T	R	R	T
	LTE 66	18.5	70.8	>50	<50	<50	>50	>50	<50	R	T	T	R	R	T
	NR 2	16.5	44.7	>50	<50	<50	>50	>50	<50	R	R	R	R	R	R
	NR 5	20.5	112.2	>50	<50	<50	>50	>50	<50	R	T	T	R	R	T
	NR 7	14.0	25.1	>50	<50	<50	>50	>50	<50	R	T	T	R	R	T
	NR 25	16.5	44.7	>50	<50	<50	>50	>50	<50	R	T	T	R	R	T
	NR 30	18.0	63.1	>50	<50	<50	>50	>50	<50	R	T	T	R	R	T
	NR 38	15.0	31.6	>50	<50	<50	>50	>50	<50	R	R	R	R	R	R
	NR 41	16.0	39.8	>50	<50	<50	>50	>50	<50	R	T	T	R	R	T
	NR 66	19.0	79.4	>50	<50	<50	>50	>50	<50	R	T	T	R	R	T
	NR 77	16.0	39.8	>50	<50	<50	>50	>50	<50	R	T	T	R	R	T
	NR 78	14.0	25.1	>50	<50	<50	>50	>50	<50	R	R	R	R	R	R

Antenna	Band Name	Output power		Laptop	Back Face	Top Edge	Bottom Edge	Left Edge	Right Edge
		dBm	mW						
WWAN (Aux Ant8)	LTE 2	19.0	79.4	>50	<50	<50	>50	>50	<50
	LTE 4	19.0	79.4	>50	<50	<50	>50	>50	<50
	LTE 7	14.0	25.1	>50	<50	<50	>50	>50	<50
	LTE 25	19.0	79.4	>50	<50	<50	>50	>50	<50
	LTE 30	16.5	44.7	>50	<50	<50	>50	>50	<50
	LTE 41	14.0	25.1	>50	<50	<50	>50	>50	<50
	LTE 66	19.0	79.4	>50	<50	<50	>50	>50	<50
	NR 2	18.0	63.1	>50	<50	<50	>50	>50	<50
	NR 38	14.5	28.2	>50	<50	<50	>50	>50	<50
	NR 41	14.0	25.1	>50	<50	<50	>50	>50	<50
	NR 66	19.0	79.4	>50	<50	<50	>50	>50	<50
	NR 77	15.0	31.6	>50	<50	<50	>50	>50	<50
NR 78	15.5	35.5	>50	<50	<50	>50	>50	<50	

Laptop	Back Face	Top Edge	Bottom Edge	Left Edge	Right Edge
R	R	R	R	R	R
R	R	R	R	R	R
R	T	T	R	R	T
R	T	T	R	R	T
R	T	T	R	R	T
R	T	T	R	R	T
R	T	T	R	R	T
R	T	T	R	R	T
R	T	T	R	R	T
R	T	T	R	R	T
R	T	T	R	R	T
R	T	T	R	R	T

T: Tested position
R: Reduced

See Annex F for a more detailed explanation of the separation distance related to the platform.

In order to evaluate SAR test exclusion for laptop and tablet user positions in which the separation distance passes the 50mm limit, equations (2) and (3) are used with the corresponding frequencies for each band, the user distances for the two positions and with the power values described on Section 6. The table below shows all cellular bands evaluated in this report grouped by frequency band, separation distances and the corresponding Power threshold in mW for each combination (distance and frequency)

Bands	Frequency	Separation distance to the body on mm										Threshold values in mW
		60	70	80	90	100	110	160	170	190	200	
LTE 12,13, 14, 17	750	223	273	323	373	423	473	723	773	873	923	
FDD V LTE 5, 26 NR 5	835	220	275	331	387	442	498	776	832	943	999	
FDD IV LTE 4, 66 NR 66	1750	213	313	413	513	613	713	1213	1313	1513	1613	
FDD II LTE 2, 25 NR 2, 25	1900	209	309	409	509	609	709	1209	1309	1509	1609	
LTE 30 NR 30	2300	199	299	399	499	599	699	1199	1299	1499	1599	
LTE 7, 38, 41 NR 7, 38, 41	2600	193	293	393	493	593	693	1193	1293	1493	1593	
LTE 48 NR 77, 78	3700	180	280	380	480	580	680	1180	1280	1480	1580	

The highest output power for all bands in tablet mode is 112.2mW which is smaller than all the values of the table, SAR is not required for the tablet bottom and left edge positions

The highest output power for all bands in notebook mode is 501.2mW which is smaller than all the values of the table, for distances >160mm. Since the considered distance between the user body and the antenna is minimum 200mm, SAR is not required for the notebook mode position. Refer to annex F3 for antenna position using notebook mode,

B.1.3.2 General SAR test reduction

According to FCC OET KDB 447498 D01, testing of other required channels within the operating mode of a frequency band is not required when the reported 1-g or 10-g SAR for the mid-band or highest output power channel is:

- ≤ 0.8 W/kg or 2.0 W/kg, for 1-g or 10-g respectively, when the transmission band is ≤ 100 MHz
- ≤ 0.6 W/kg or 1.5 W/kg, for 1-g or 10-g respectively, when the transmission band is between 100 MHz and 200 MHz
- ≤ 0.4 W/kg or 1.0 W/kg, for 1-g or 10-g respectively, when the transmission band is ≥ 200 MHz

WWAN SAR Test reduction

Transmission Mode	SAR test exclusion/reduction
HSDPA	According to FCC OET KDB 941225 D01, SAR evaluation is not required when the maximum average output power is $< \frac{1}{4}$ dB higher than the measured on the corresponding channels without HSDPA, using 12.2kbps RMC, and the maximum SAR for 12.2kbps RMC is < 1.2 W/kg.
HSUPA	According to FCC OET KDB 941225 D01, SAR evaluation is not required when the maximum average output power is $< \frac{1}{4}$ dB higher than the measured on the corresponding channels without HSUPA, using 12.2kbps RMC, and the maximum SAR for 12.2kbps RMC is < 1.2 W/kg.
DC+HSDPA	According to FCC OET KDB 941225 D01, SAR evaluation is not required when the maximum average output power is $< \frac{1}{4}$ dB higher than the measured on the corresponding channels without DC+HSDPA, using 12.2kbps RMC, and the maximum SAR for 12.2kbps RMC is < 1.2 W/kg.
LTE	<p>According to FCC OET KDB 941225 D05, testing of 100% RB allocation, higher order modulations or lower BW is not required when these conditions are met:</p> <ul style="list-style-type: none"> ○ For QPSK with 100% RB allocation, SAR is not required when the highest maximum output power for 100 % RB allocation is less than the highest maximum output power in 50% and 1 RB allocations and the highest reported SAR for 1 RB and 50% RB allocation are ≤ 0.8 W/kg. ○ For each modulation besides QPSK, SAR is required only when the highest maximum output power for the configuration in the higher order modulation is $> \frac{1}{2}$ dB higher than the same configuration in QPSK or when the reported SAR for the QPSK configuration is > 1.45 W/kg. ○ For lower BW, only measure SAR when the highest maximum output power of a configuration requiring testing in the smaller channel bandwidth is $> \frac{1}{2}$ dB higher than the equivalent channel configurations in the largest channel bandwidth configuration or the reported SAR of a configuration for the largest channel bandwidth is > 1.45 W/kg. <p>For LTE bands that do not support at least three non-overlapping channels in certain channel bandwidths, test the available non-overlapping channels instead. When a device supports overlapping channel assignment in a channel bandwidth configuration, the middle channel of the group of overlapping channels should be selected for testing; therefore, the requirement for H, M, and L channels may not fully apply</p>
5G NR	According to TCB workshop November 2019; RF Exposure Policy Updates (5G NR FR1 NSA EN-DC UE SAR Evaluations), the FCC OET KDB 941225 D05 rules apply.

B.2 Conducted Power Measurements – Tablet mode

B.2.1 WCDMA/ HSPA/ DC-HSPA

B.2.1.1 WCDMA Band II Antenna 5

Mode	Channel Number	Freq (MHz)	Subset	MPR	Average Power Measured (dBm)	Factory Upper Tolerance (dBm)
RMC	9262	1852.4	-	0	15.94	16.50
	9400	1880	-	0	15.96	16.50
	9538	1907.6	-	0	15.90	16.50
HSDPA	9262	1852.4	1	0	15.98	16.50
			2	0	15.99	16.50
			3	0	16.02	16.50
			4	0	15.99	16.50
	9400	1880	1	0	16.00	16.50
			2	0	15.99	16.50
			3	0	16.05	16.50
			4	0	16.02	16.50
	9538	1907.6	1	0	15.92	16.50
			2	0	15.91	16.50
			3	0	15.94	16.50
			4	0	15.92	16.50
HSUPA	9262	1852.4	1	0	15.30	16.50
			2	2	NM	16.50
			3	1	NM	16.50
			4	2	NM	16.50
			5	0	15.38	16.50
	9400	1880	1	0	15.35	16.50
			2	2	NM	16.50
			3	1	NM	16.50
			4	2	NM	16.50
			5	0	15.35	16.50
	9538	1907.6	1	0	15.20	16.50
			2	2	NM	16.50
			3	1	NM	16.50
			4	2	NM	16.50
			5	0	15.65	16.50
DC-HSDPA	9262	1852.4	1	0	15.97	16.50
			2	0	16.01	16.50
			3	0	16.02	16.50
			4	0	15.99	16.50
	9400	1880	1	0	15.98	16.50
			2	0	16.00	16.50
			3	0	16.03	16.50
			4	0	15.98	16.50
	9538	1907.6	1	0	15.93	16.50
			2	0	15.92	16.50
			3	0	15.97	16.50
			4	0	15.96	16.50

NM: Not measured

NA: Not applicable

B.2.1.2 WCDMA Band IV Antenna 5

Mode	Channel Number	Freq (MHz)	Subset	MPR	Average Power Measured (dBm)	Factory Upper Tolerance (dBm)
RMC	1312	1712.4	-	0	18.77	19.00
	1413	1732.6	-	0	18.65	19.00
	1513	1752.6	-	0	18.64	19.00
HSDPA	1312	1712.4	1	0	18.67	19.00
			2	0	18.65	19.00
			3	0	18.71	19.00
			4	0	18.68	19.00
	1413	1732.6	1	0	18.56	19.00
			2	0	18.55	19.00
			3	0	18.58	19.00
			4	0	18.57	19.00
	1513	1752.6	1	0	18.54	19.00
			2	0	18.53	19.00
			3	0	18.57	19.00
			4	0	18.52	19.00
HSUPA	1312	1712.4	1	0	18.10	19.00
			2	2	NM	19.00
			3	1	NM	19.00
			4	2	NM	19.00
			5	0	17.95	19.00
	1413	1732.6	1	0	18.15	19.00
			2	2	NM	19.00
			3	1	NM	19.00
			4	2	NM	19.00
			5	0	17.95	19.00
	1513	1752.6	1	0	17.90	19.00
			2	2	NM	19.00
			3	1	NM	19.00
			4	2	NM	19.00
			5	0	17.90	19.00
DC-HSDPA	1312	1712.4	1	0	18.68	19.00
			2	0	18.67	19.00
			3	0	18.74	19.00
			4	0	18.68	19.00
	1413	1732.6	1	0	18.56	19.00
			2	0	18.56	19.00
			3	0	18.60	19.00
			4	0	18.57	19.00
	1513	1752.6	1	0	18.56	19.00
			2	0	18.52	19.00
			3	0	18.59	19.00
			4	0	18.53	19.00

NM: Not measured

NA: Not applicable

B.2.1.3 WCDMA Band V Antenna 5

Mode	Channel Number	Freq (MHz)	Subset	MPR	Average Power Measured (dBm)	Factory Upper Tolerance (dBm)
RMC	4132	826.4	-	0	20.05	20.50
	4183	836.6	-	0	19.97	20.50
	4233	846.6	-	0	19.99	20.50
HSDPA	4132	826.4	1	0	20.04	20.50
			2	0	20.06	20.50
			3	0	20.13	20.50
			4	0	20.11	20.50
	4183	836.6	1	0	19.96	20.50
			2	0	19.96	20.50
			3	0	20.05	20.50
			4	0	19.98	20.50
	4233	846.6	1	0	20.00	20.50
			2	0	19.99	20.50
			3	0	20.04	20.50
			4	0	20.01	20.50
HSUPA	4132	826.4	1	0	19.30	20.50
			2	2	NM	20.50
			3	1	NM	20.50
			4	2	NM	20.50
			5	0	19.36	20.50
	4183	836.6	1	0	19.25	20.50
			2	2	NM	20.50
			3	1	NM	20.50
			4	2	NM	20.50
			5	0	19.5	20.50
	4233	846.6	1	0	19.28	20.50
			2	2	NM	20.50
			3	1	NM	20.50
			4	2	NM	20.50
			5	0	19.38	20.50
DC- HSDPA	4132	826.4	1	0	20.07	20.50
			2	0	20.08	20.50
			3	0	20.14	20.50
			4	0	20.10	20.50
	4183	836.6	1	0	19.97	20.50
			2	0	19.98	20.50
			3	0	20.03	20.50
			4	0	19.99	20.50
	4233	846.6	1	0	20.01	20.50
			2	0	19.99	20.50
			3	0	20.07	20.50
			4	0	20.03	20.50

NM: Not measured

NA: Not applicable

B.2.2 LTE

B.2.2.1 LTE Band 2 FDD Antenna Main 5 & Antenna Aux 8

SAR Measurement for LTE Band 2 FDD (Frequency range: 1850 – 1910MHz) is covered by LTE Band 25 FDD (Frequency range: 1850 – 1915MHz) due to overlapping frequency range, same maximum tune-up and same bandwidth.

B.2.2.2 LTE Band 4 FDD Antenna Main 5 & Antenna Aux 8

SAR Measurement for LTE Band 4 FDD (Frequency range: 1710 – 1755MHz) is covered by LTE Band 66 FDD (Frequency range: 1710 – 1780MHz) due to overlapping frequency range, same maximum tune-up and same bandwidth.

B.2.2.3 LTE band 5 FDD Antenna Main 5

Band	BW	Channel #	Freq (MHz)	% RB Allocation	RB Position	QPSK			16 QAM			
						Factory Upper Tolerance (dBm)	M P R	Measured Output Power (dBm)	Factory Upper Tolerance (dBm)	M P R	Measured Output Power (dBm)	
LTE 5	10 MHz	20525	836.5	1RB Low	1 Pos 0	20.50	0	19.53	20.50	1	18.82	
				1RB Mid	1 Pos 50	20.50	0	19.50	20.50	1	18.79	
				1RB High	1 Pos 99	20.50	0	19.43	20.50	1	18.75	
				50% RB Low	50 Pos 0	20.50	1	18.49	20.50	2	17.55	
				50% RB Mid	50 Pos 24	20.50	1	18.55	20.50	2	17.56	
				50% RB High	50 Pos 50	20.50	1	18.52	20.50	2	17.52	
	100% RB	100 Pos 0	20.50	1	18.51	20.50	2	17.50				
	5 MHz	20425	826.5	1RB Low	1 Pos 0	20.50	0	19.53	20.50	1	18.83	
				1RB Mid	1 Pos 38	20.50	0	19.51	20.50	1	18.79	
				1RB High	1 Pos 74	20.50	0	19.52	20.50	1	18.80	
				50% RB Low	38 Pos 0	20.50	1	18.61	20.50	2	17.64	
				50% RB Mid	38 Pos 19	20.50	1	18.56	20.50	2	17.60	
				50% RB High	38 Pos 39	20.50	1	18.50	20.50	2	17.53	
		100% RB	75 Pos 0	20.50	1	18.58	20.50	2	17.58			
		20525	836.5	1RB Low	1 Pos 0	20.50	0	19.44	20.50	1	18.75	
				1RB Mid	1 Pos 38	20.50	0	19.45	20.50	1	18.79	
				1RB High	1 Pos 74	20.50	0	19.43	20.50	1	18.79	
				50% RB Low	38 Pos 0	20.50	1	18.49	20.50	2	17.49	
				50% RB Mid	38 Pos 19	20.50	1	18.45	20.50	2	17.49	
				50% RB High	38 Pos 39	20.50	1	18.45	20.50	2	17.48	
		100% RB	75 Pos 0	20.50	1	18.49	20.50	2	17.44			
		20625	846.5	1RB Low	1 Pos 0	20.50	0	19.56	20.50	1	18.44	
				1RB Mid	1 Pos 38	20.50	0	19.62	20.50	1	18.44	
				1RB High	1 Pos 74	20.50	0	19.61	20.50	1	18.41	
				50% RB Low	38 Pos 0	20.50	1	18.55	20.50	2	17.60	
				50% RB Mid	38 Pos 19	20.50	1	18.50	20.50	2	17.56	
				50% RB High	38 Pos 39	20.50	1	18.47	20.50	2	17.52	
		100% RB	75 Pos 0	20.50	1	18.55	20.50	2	17.57			
		3 MHz	20415	825.5	1RB Low	1 Pos 0	20.50	0	19.51	20.50	1	18.81
					1RB Mid	1 Pos 24	20.50	0	19.50	20.50	1	18.78
					1RB High	1 Pos 49	20.50	0	19.54	20.50	1	18.79
	50% RB Low				25 Pos 0	20.50	1	18.45	20.50	2	17.50	
	50% RB Mid				25 Pos 12	20.50	1	18.49	20.50	2	17.45	
	50% RB High				25 Pos 25	20.50	1	18.46	20.50	2	17.41	
	100% RB		50 Pos 0	20.50	1	18.51	20.50	2	17.52			
	20525		836.5	1RB Low	1 Pos 0	20.50	0	19.32	20.50	1	18.41	
				1RB Mid	1 Pos 24	20.50	0	19.33	20.50	1	18.44	
				1RB High	1 Pos 49	20.50	0	19.29	20.50	1	18.37	
				50% RB Low	25 Pos 0	20.50	1	19.28	20.50	1	18.62	
				50% RB Mid	25 Pos 12	20.50	1	19.28	20.50	1	18.61	
				50% RB High	25 Pos 25	20.50	1	19.27	20.50	1	18.63	
	100% RB		50 Pos 0	20.50	1	18.44	20.50	2	17.56			
	20635		847.5	1RB Low	1 Pos 0	20.50	0	19.53	20.50	1	18.72	
				1RB Mid	1 Pos 24	20.50	0	19.53	20.50	1	18.68	
				1RB High	1 Pos 49	20.50	0	19.47	20.50	1	18.59	
				50% RB Low	25 Pos 0	20.50	1	18.52	20.50	2	17.60	
		50% RB Mid		25 Pos 12	20.50	1	18.49	20.50	2	17.56		
		50% RB High		25 Pos 25	20.50	1	18.51	20.50	2	17.51		
100% RB	50 Pos 0	20.50	1	18.50	20.50	2	17.51					

Band	BW	Channel #	Freq (MHz)	% RB Allocation	RB Position	QPSK			16 QAM		
						Factory Upper Tolerance (dBm)	M P R	Measured Output Power (dBm)	Factory Upper Tolerance (dBm)	M P R	Measured Output Power (dBm)
LTE 5	1.4 MHz	20407	824.7	1RB Low	1 Pos 0	20.50	0	19.52	20.50	1	18.49
				1RB Mid	1 Pos 2	20.50	0	19.62	20.50	1	18.55
				1RB High	1 Pos 5	20.50	0	19.55	20.50	1	18.53
				50% RB Low	3 Pos 0	20.50	0	19.49	20.50	1	18.66
				50% RB Mid	3 Pos 1	20.50	0	19.51	20.50	1	18.65
				50% RB High	3 Pos 2	20.50	0	19.49	20.50	1	18.64
		20525	836.5	100% RB	6 Pos 0	20.50	1	18.48	20.50	2	17.51
				1RB Low	1 Pos 0	20.50	0	19.40	20.50	1	18.53
				1RB Mid	1 Pos 2	20.50	0	19.46	20.50	1	18.58
				1RB High	1 Pos 5	20.50	0	19.37	20.50	1	18.53
				50% RB Low	3 Pos 0	20.50	0	19.39	20.50	1	18.69
				50% RB Mid	3 Pos 1	20.50	0	19.38	20.50	1	18.69
		20643	848.3	50% RB High	3 Pos 2	20.50	0	19.35	20.50	1	18.68
				100% RB	6 Pos 0	20.50	1	18.50	20.50	2	17.59
				1RB Low	1 Pos 0	20.50	0	19.45	20.50	1	18.78
				1RB Mid	1 Pos 2	20.50	0	19.41	20.50	1	18.71
				1RB High	1 Pos 5	20.50	0	19.46	20.50	1	18.75
				50% RB Low	3 Pos 0	20.50	1	18.49	20.50	2	17.51
		50% RB Mid	3 Pos 1	20.50	1	18.44	20.50	2	17.49		
		50% RB High	3 Pos 2	20.50	1	18.41	20.50	2	17.47		
		100% RB	6 Pos 0	20.50	1	18.47	20.50	2	17.44		

B.2.2.4 LTE Band 7 FDD Antenna Main 5

Band	BW	Channel #	Freq (MHz)	% RB Allocation	RB Position	QPSK			16 QAM		
						Factory Upper Tolerance (dBm)	M P R	Measured Output Power (dBm)	Factory Upper Tolerance (dBm)	M P R	Measured Output Power (dBm)
LTE 7	20 MHz	20850	2510	1RB Low	1 Pos 0	14.00	0	13.56	14.00	1	12.76
				1RB Mid	1 Pos 50	14.00	0	13.70	14.00	1	12.86
				1RB High	1 Pos 99	14.00	0	13.53	14.00	1	12.69
				50% RB Low	50 Pos 0	14.00	1	12.67	14.00	2	11.74
				50% RB Mid	50 Pos 24	14.00	1	12.66	14.00	2	11.73
				50% RB High	50 Pos 50	14.00	1	12.68	14.00	2	11.73
		100% RB	100 Pos 0	14.00	1	12.64	14.00	2	11.69		
		21100	2535	1RB Low	1 Pos 0	14.00	0	13.54	14.00	1	12.30
				1RB Mid	1 Pos 50	14.00	0	13.71	14.00	1	12.48
				1RB High	1 Pos 99	14.00	0	13.58	14.00	1	12.34
				50% RB Low	50 Pos 0	14.00	1	12.65	14.00	2	11.71
				50% RB Mid	50 Pos 24	14.00	1	12.66	14.00	2	11.65
				50% RB High	50 Pos 50	14.00	1	12.63	14.00	2	11.62
		100% RB	100 Pos 0	14.00	1	12.66	14.00	2	11.61		
		21350	2560	1RB Low	1 Pos 0	14.00	0	13.54	14.00	1	12.33
				1RB Mid	1 Pos 50	14.00	0	13.75	14.00	1	12.52
				1RB High	1 Pos 99	14.00	0	13.64	14.00	1	12.40
				50% RB Low	50 Pos 0	14.00	1	12.67	14.00	2	11.61
	50% RB Mid			50 Pos 24	14.00	1	12.62	14.00	2	11.56	
	50% RB High			50 Pos 50	14.00	1	12.67	14.00	2	11.57	
	100% RB	100 Pos 0	14.00	1	12.66	14.00	2	11.63			
	15 MHz	20825	2507.5	1RB Low	1 Pos 0	14.00	0	13.62	14.00	1	12.89
				1RB Mid	1 Pos 38	14.00	0	13.55	14.00	1	12.87
				1RB High	1 Pos 74	14.00	0	13.69	14.00	1	13.00
				50% RB Low	38 Pos 0	14.00	1	12.61	14.00	2	11.76
				50% RB Mid	38 Pos 19	14.00	1	12.67	14.00	2	11.75
				50% RB High	38 Pos 39	14.00	1	12.59	14.00	2	11.72
		100% RB	75 Pos 0	14.00	1	12.66	14.00	2	11.73		
		21100	2535	1RB Low	1 Pos 0	14.00	0	13.59	14.00	1	12.64
				1RB Mid	1 Pos 38	14.00	0	13.50	14.00	1	12.56
				1RB High	1 Pos 74	14.00	0	13.63	14.00	1	12.78
				50% RB Low	38 Pos 0	14.00	1	12.60	14.00	2	11.57
				50% RB Mid	38 Pos 19	14.00	1	12.60	14.00	2	11.57
				50% RB High	38 Pos 39	14.00	1	12.56	14.00	2	11.58
		100% RB	75 Pos 0	14.00	1	12.60	14.00	2	11.59		
		21375	2562.5	1RB Low	1 Pos 0	14.00	0	13.58	14.00	1	12.69
				1RB Mid	1 Pos 38	14.00	0	13.55	14.00	1	12.74
				1RB High	1 Pos 74	14.00	0	13.63	14.00	1	12.83
				50% RB Low	38 Pos 0	14.00	1	12.54	14.00	2	11.58
	50% RB Mid			38 Pos 19	14.00	1	12.60	14.00	2	11.67	
	50% RB High			38 Pos 39	14.00	1	12.63	14.00	2	11.63	
	100% RB	75 Pos 0	14.00	1	12.65	14.00	2	11.61			
	10 MHz	20800	2505	1RB Low	1 Pos 0	14.00	0	13.71	14.00	1	12.99
				1RB Mid	1 Pos 24	14.00	0	13.73	14.00	1	13.00
				1RB High	1 Pos 49	14.00	0	13.69	14.00	1	12.99
				50% RB Low	25 Pos 0	14.00	1	12.69	14.00	2	11.80
				50% RB Mid	25 Pos 12	14.00	1	12.67	14.00	2	11.85
				50% RB High	25 Pos 25	14.00	1	12.71	14.00	2	11.82
100% RB		50 Pos0	14.00	1	12.71	14.00	2	11.77			
21100		2535	1RB Low	1 Pos 0	14.00	0	13.71	14.00	1	12.52	
			1RB Mid	1 Pos 24	14.00	0	13.72	14.00	1	12.53	
			1RB High	1 Pos 49	14.00	0	13.68	14.00	1	12.50	
			50% RB Low	25 Pos 0	14.00	1	12.64	14.00	2	11.63	
			50% RB Mid	25 Pos 12	14.00	1	12.63	14.00	2	11.61	
			50% RB High	25 Pos 25	14.00	1	12.65	14.00	2	11.61	
100% RB		50 Pos0	14.00	1	12.67	14.00	2	11.65			
21400		2565	1RB Low	1 Pos 0	14.00	0	13.66	14.00	1	12.81	
			1RB Mid	1 Pos 24	14.00	0	13.70	14.00	1	12.83	
			1RB High	1 Pos 49	14.00	0	13.71	14.00	1	12.83	
			50% RB Low	25 Pos 0	14.00	1	12.63	14.00	2	11.65	
	50% RB Mid		25 Pos 12	14.00	1	12.64	14.00	2	11.65		
	50% RB High		25 Pos 25	14.00	1	12.72	14.00	2	11.71		
100% RB	50 Pos0	14.00	1	12.71	14.00	2	11.66				

Band	BW	Channel #	Freq (MHz)	% RB Allocation	RB Position	QPSK			16 QAM		
						Factory Upper Tolerance (dBm)	M P R	Measured Output Power (dBm)	Factory Upper Tolerance (dBm)	M P R	Measured Output Power (dBm)
LTE 7	5 MHz	20775	2502.5	1RB Low	1 Pos 0	14.00	0	13.74	14.00	1	13.00
				1RB Mid	1 Pos 12	14.00	0	13.72	14.00	1	13.00
				1RB High	1 Pos 24	14.00	0	13.74	14.00	1	13.00
				50% RB Low	12 Pos 0	14.00	1	12.67	14.00	2	11.72
				50% RB Mid	12 Pos 6	14.00	1	12.67	14.00	2	11.71
				50% RB High	12 Pos 11	14.00	1	12.65	14.00	2	11.73
		21100	2535	100% RB	25 Pos 0	14.00	1	12.71	14.00	2	11.77
				1RB Low	1 Pos 0	14.00	0	13.66	14.00	1	12.91
				1RB Mid	1 Pos 12	14.00	0	13.68	14.00	1	12.93
				1RB High	1 Pos 24	14.00	0	13.63	14.00	1	12.90
				50% RB Low	12 Pos 0	14.00	1	12.63	14.00	2	11.68
				50% RB Mid	12 Pos 6	14.00	1	12.64	14.00	2	11.64
		21425	2567.5	50% RB High	12 Pos 11	14.00	1	12.58	14.00	2	11.71
				100% RB	25 Pos 0	14.00	1	12.61	14.00	2	11.72
				1RB Low	1 Pos 0	14.00	0	13.65	14.00	1	12.89
				1RB Mid	1 Pos 12	14.00	0	13.69	14.00	1	12.91
				1RB High	1 Pos 24	14.00	0	13.73	14.00	1	12.91
				50% RB Low	12 Pos 0	14.00	1	12.69	14.00	2	11.61
		50% RB Mid	12 Pos 6	14.00	1	12.67	14.00	2	11.61		
		50% RB High	12 Pos 11	14.00	1	12.68	14.00	2	11.60		
		100% RB	25 Pos 0	14.00	1	12.68	14.00	2	11.60		

B.2.2.5 LTE Band 7 FDD Antenna Aux 8

Band	BW	Channel #	Freq (MHz)	% RB Allocation	RB Position	QPSK			16 QAM		
						Factory Upper Tolerance (dBm)	M P R	Measured Output Power (dBm)	Factory Upper Tolerance (dBm)	M P R	Measured Output Power (dBm)
LTE 7	20 MHz	20850	2510	1RB Low	1 Pos 0	14.00	0	13.64	14.00	1	12.90
				1RB Mid	1 Pos 50	14.00	0	13.76	14.00	1	13.03
				1RB High	1 Pos 99	14.00	0	13.65	14.00	1	12.93
				50% RB Low	50 Pos 0	14.00	1	12.68	14.00	2	11.64
				50% RB Mid	50 Pos 24	14.00	1	12.69	14.00	2	11.66
				50% RB High	50 Pos 50	14.00	1	12.70	14.00	2	11.67
		100% RB	100 Pos 0	14.00	1	12.71	14.00	2	11.67		
		21100	2535	1RB Low	1 Pos 0	14.00	0	13.51	14.00	1	13.07
				1RB Mid	1 Pos 50	14.00	0	13.73	14.00	1	13.29
				1RB High	1 Pos 99	14.00	0	13.65	14.00	1	13.21
				50% RB Low	50 Pos 0	14.00	1	12.72	14.00	2	11.69
				50% RB Mid	50 Pos 24	14.00	1	12.79	14.00	2	11.75
				50% RB High	50 Pos 50	14.00	1	12.70	14.00	2	11.68
		100% RB	100 Pos 0	14.00	1	12.71	14.00	2	11.65		
		21350	2560	1RB Low	1 Pos 0	14.00	0	13.65	14.00	1	12.88
				1RB Mid	1 Pos 50	14.00	0	13.89	14.00	1	13.05
				1RB High	1 Pos 99	14.00	0	13.78	14.00	1	12.96
				50% RB Low	50 Pos 0	14.00	1	12.82	14.00	2	11.77
	50% RB Mid			50 Pos 24	14.00	1	12.79	14.00	2	11.78	
	50% RB High			50 Pos 50	14.00	1	12.80	14.00	2	11.80	
	100% RB	100 Pos 0	14.00	1	12.78	14.00	2	11.77			
	15 MHz	20825	2507.5	1RB Low	1 Pos 0	14.00	0	13.61	14.00	1	13.22
				1RB Mid	1 Pos 38	14.00	0	13.55	14.00	1	13.17
				1RB High	1 Pos 74	14.00	0	13.66	14.00	1	13.32
				50% RB Low	38 Pos 0	14.00	1	12.69	14.00	2	11.68
				50% RB Mid	38 Pos 19	14.00	1	12.68	14.00	2	11.69
				50% RB High	38 Pos 39	14.00	1	12.66	14.00	2	11.69
		100% RB	75 Pos 0	14.00	1	12.66	14.00	2	11.66		
		21100	2535	1RB Low	1 Pos 0	14.00	0	13.54	14.00	1	13.02
				1RB Mid	1 Pos 38	14.00	0	13.61	14.00	1	13.05
				1RB High	1 Pos 74	14.00	0	13.70	14.00	1	13.10
				50% RB Low	38 Pos 0	14.00	1	12.67	14.00	2	11.67
				50% RB Mid	38 Pos 19	14.00	1	12.72	14.00	2	11.72
				50% RB High	38 Pos 39	14.00	1	12.67	14.00	2	11.66
		100% RB	75 Pos 0	14.00	1	12.69	14.00	2	11.66		
		21375	2562.5	1RB Low	1 Pos 0	14.00	0	13.67	14.00	1	12.80
				1RB Mid	1 Pos 38	14.00	0	13.74	14.00	1	12.88
				1RB High	1 Pos 74	14.00	0	13.70	14.00	1	12.85
				50% RB Low	38 Pos 0	14.00	1	12.73	14.00	2	11.69
	50% RB Mid			38 Pos 19	14.00	1	12.75	14.00	2	11.74	
	50% RB High			38 Pos 39	14.00	1	12.70	14.00	2	11.75	
	100% RB	75 Pos 0	14.00	1	12.77	14.00	2	11.73			
	10 MHz	20800	2505	1RB Low	1 Pos 0	14.00	0	13.66	14.00	1	13.32
				1RB Mid	1 Pos 24	14.00	0	13.72	14.00	1	13.31
				1RB High	1 Pos 49	14.00	0	13.69	14.00	1	13.31
				50% RB Low	25 Pos 0	14.00	1	12.69	14.00	2	11.73
				50% RB Mid	25 Pos 12	14.00	1	12.71	14.00	2	11.74
				50% RB High	25 Pos 25	14.00	1	12.70	14.00	2	11.76
100% RB		50 Pos0	14.00	1	12.73	14.00	2	11.71			
21100		2535	1RB Low	1 Pos 0	14.00	0	13.70	14.00	1	12.72	
			1RB Mid	1 Pos 24	14.00	0	13.77	14.00	1	12.74	
			1RB High	1 Pos 49	14.00	0	13.71	14.00	1	12.71	
			50% RB Low	25 Pos 0	14.00	1	12.71	14.00	2	11.81	
			50% RB Mid	25 Pos 12	14.00	1	12.75	14.00	2	11.82	
			50% RB High	25 Pos 25	14.00	1	12.74	14.00	2	11.83	
100% RB		50 Pos0	14.00	1	12.78	14.00	2	11.77			
21400		2565	1RB Low	1 Pos 0	14.00	0	13.75	14.00	1	12.87	
			1RB Mid	1 Pos 24	14.00	0	13.78	14.00	1	12.87	
			1RB High	1 Pos 49	14.00	0	13.77	14.00	1	12.89	
			50% RB Low	25 Pos 0	14.00	1	12.70	14.00	2	11.76	
	50% RB Mid		25 Pos 12	14.00	1	12.70	14.00	2	11.76		
	50% RB High		25 Pos 25	14.00	1	12.75	14.00	2	11.79		
100% RB	50 Pos0	14.00	1	12.78	14.00	2	11.74				

Band	BW	Channel #	Freq (MHz)	% RB Allocation	RB Position	QPSK			16 QAM		
						Factory Upper Tolerance (dBm)	M P R	Measured Output Power (dBm)	Factory Upper Tolerance (dBm)	M P R	Measured Output Power (dBm)
LTE 7	5 MHz	20775	2502.5	1RB Low	1 Pos 0	14.00	0	13.73	14.00	1	12.80
				1RB Mid	1 Pos 12	14.00	0	13.74	14.00	1	12.77
				1RB High	1 Pos 24	14.00	0	13.76	14.00	1	12.81
				50% RB Low	12 Pos 0	14.00	1	12.68	14.00	2	11.66
				50% RB Mid	12 Pos 6	14.00	1	12.69	14.00	2	11.65
				50% RB High	12 Pos 11	14.00	1	12.66	14.00	2	11.64
				100% RB	25 Pos 0	14.00	1	12.69	14.00	2	11.71
		21100	2535	1RB Low	1 Pos 0	14.00	0	13.76	14.00	1	13.01
				1RB Mid	1 Pos 12	14.00	0	13.76	14.00	1	13.02
				1RB High	1 Pos 24	14.00	0	13.78	14.00	1	13.01
				50% RB Low	12 Pos 0	14.00	1	12.70	14.00	2	11.73
				50% RB Mid	12 Pos 6	14.00	1	12.69	14.00	2	11.70
				50% RB High	12 Pos 11	14.00	1	12.66	14.00	2	11.65
				100% RB	25 Pos 0	14.00	1	12.67	14.00	2	11.69
		21425	2567.5	1RB Low	1 Pos 0	14.00	0	13.73	14.00	1	12.60
				1RB Mid	1 Pos 12	14.00	0	13.85	14.00	1	12.63
				1RB High	1 Pos 24	14.00	0	13.85	14.00	1	12.72
				50% RB Low	12 Pos 0	14.00	1	12.69	14.00	2	11.67
				50% RB Mid	12 Pos 6	14.00	1	12.73	14.00	2	11.68
				50% RB High	12 Pos 11	14.00	1	12.75	14.00	2	11.72
				100% RB	25 Pos 0	14.00	1	12.72	14.00	2	11.77

B.2.2.6 LTE Band 12 FDD Antenna Main 5

Band	BW	Channel #	Freq (MHz)	% RB Allocation	RB Position	QPSK			16 QAM		
						Factory Upper Tolerance (dBm)	M P R	Measured Output Power (dBm)	Factory Upper Tolerance (dBm)	M P R	Measured Output Power (dBm)
LTE 12	10 MHz	23095	707.5	1RB Low	1 Pos 0	19.50	0	18.55	19.50	1	17.83
				1RB Mid	1 Pos 24	19.50	0	18.46	19.50	1	17.76
				1RB High	1 Pos 49	19.50	0	18.46	19.50	1	17.71
				50% RB Low	25 Pos 0	19.50	1	17.43	19.50	2	16.49
				50% RB Mid	25 Pos 12	19.50	1	17.43	19.50	2	16.49
				50% RB High	25 Pos 24	19.50	1	17.48	19.50	2	16.55
	5 MHz	23035	701.5	1RB Low	1 Pos 0	19.50	0	18.53	19.50	1	17.67
				1RB Mid	1 Pos 12	19.50	0	18.51	19.50	1	17.71
				1RB High	1 Pos 24	19.50	0	18.59	19.50	1	17.75
				50% RB Low	12 Pos 0	19.50	1	17.49	19.50	2	16.46
				50% RB Mid	12 Pos 6	19.50	1	17.45	19.50	2	16.41
				50% RB High	12 Pos 11	19.50	1	17.45	19.50	2	16.38
		23095	707.5	100% RB	25 Pos 0	19.50	1	17.44	19.50	2	16.50
				1RB Low	1 Pos 0	19.50	0	18.48	19.50	1	17.67
				1RB Mid	1 Pos 12	19.50	0	18.48	19.50	1	17.75
				1RB High	1 Pos 24	19.50	0	18.40	19.50	1	17.65
				50% RB Low	12 Pos 0	19.50	1	17.40	19.50	2	16.44
				50% RB Mid	12 Pos 6	19.50	1	17.44	19.50	2	16.45
	23155	713.5	50% RB High	12 Pos 11	19.50	1	17.44	19.50	2	16.45	
			100% RB	25 Pos 0	19.50	1	17.42	19.50	2	16.42	
			1RB Low	1 Pos 0	19.50	0	18.47	19.50	1	17.58	
			1RB Mid	1 Pos 12	19.50	0	18.49	19.50	1	17.59	
			1RB High	1 Pos 24	19.50	0	18.53	19.50	1	17.59	
			50% RB Low	12 Pos 0	19.50	1	17.45	19.50	2	16.38	
	3 MHz	23025	700.5	50% RB Mid	12 Pos 6	19.50	1	17.39	19.50	2	16.32
				50% RB High	12 Pos 11	19.50	1	17.40	19.50	2	16.33
				100% RB	25 Pos 0	19.50	1	17.44	19.50	2	16.38
				1RB Low	1 Pos 0	19.50	0	18.46	19.50	1	17.75
				1RB Mid	1 Pos 7	19.50	0	18.52	19.50	1	17.81
				1RB High	1 Pos 14	19.50	0	18.45	19.50	1	17.75
		23095	707.5	50% RB Low	8 Pos 0	19.50	1	17.39	19.50	2	16.42
				50% RB Mid	8 Pos 4	19.50	1	17.43	19.50	2	16.45
				50% RB High	8 Pos 7	19.50	1	17.38	19.50	2	16.40
				100% RB	15 Pos 0	19.50	1	17.43	19.50	2	16.38
				1RB Low	1 Pos 0	19.50	0	18.47	19.50	1	17.76
				1RB Mid	1 Pos 7	19.50	0	18.47	19.50	1	17.77
		23165	714.5	1RB High	1 Pos 14	19.50	0	18.39	19.50	1	17.71
				50% RB Low	8 Pos 0	19.50	1	17.40	19.50	2	16.39
				50% RB Mid	8 Pos 4	19.50	1	17.43	19.50	2	16.44
				50% RB High	8 Pos 7	19.50	1	17.39	19.50	2	16.40
				100% RB	15 Pos 0	19.50	1	17.40	19.50	2	16.38
				1RB Low	1 Pos 0	19.50	0	18.42	19.50	1	17.71
	23165	714.5	1RB Mid	1 Pos 7	19.50	0	18.43	19.50	1	17.75	
			1RB High	1 Pos 14	19.50	0	18.40	19.50	1	17.69	
			50% RB Low	8 Pos 0	19.50	1	17.35	19.50	2	16.39	
			50% RB Mid	8 Pos 4	19.50	1	17.35	19.50	2	16.38	
			50% RB High	8 Pos 7	19.50	1	17.37	19.50	2	16.40	
			100% RB	15 Pos 0	19.50	1	17.36	19.50	2	16.35	

Band	BW	Channel #	Freq (MHz)	% RB Allocation	RB Position	QPSK			16 QAM		
						Factory Upper Tolerance (dBm)	M P R	Measured Output Power (dBm)	Factory Upper Tolerance (dBm)	M P R	Measured Output Power (dBm)
LTE 12	1.4 MHz	23017	699.7	1RB Low	1 Pos 0	19.50	0	18.43	19.50	1	17.36
				1RB Mid	1 Pos 2	19.50	0	18.51	19.50	1	17.45
				1RB High	1 Pos 5	19.50	0	18.46	19.50	1	17.37
				50% RB Low	3 Pos 0	19.50	1	18.39	19.50	1	17.60
				50% RB Mid	3 Pos 1	19.50	1	18.39	19.50	1	17.58
				50% RB High	3 Pos 2	19.50	1	18.45	19.50	1	17.63
		23095	707.5	100% RB	6 Pos 0	19.50	1	17.44	19.50	2	16.45
				1RB Low	1 Pos 0	19.50	0	18.52	19.50	1	17.40
				1RB Mid	1 Pos 2	19.50	0	18.53	19.50	1	17.49
				1RB High	1 Pos 5	19.50	0	18.50	19.50	1	17.43
				50% RB Low	3 Pos 0	19.50	1	18.43	19.50	1	17.62
				50% RB Mid	3 Pos 1	19.50	1	18.44	19.50	1	17.61
		23173	715.3	50% RB High	3 Pos 2	19.50	1	18.42	19.50	1	17.58
				100% RB	6 Pos 0	19.50	1	17.45	19.50	2	16.44
				1RB Low	1 Pos 0	19.50	0	18.39	19.50	1	17.30
				1RB Mid	1 Pos 2	19.50	0	18.42	19.50	1	17.34
				1RB High	1 Pos 5	19.50	0	18.41	19.50	1	17.31
				50% RB Low	3 Pos 0	19.50	1	18.35	19.50	1	17.52
		50% RB Mid	3 Pos 1	19.50	1	18.39	19.50	1	17.56		
		50% RB High	3 Pos 2	19.50	1	18.36	19.50	1	17.59		
		100% RB	6 Pos 0	19.50	1	17.38	19.50	2	16.44		

B.2.2.7 LTE Band 13 FDD Antenna Main 5

Band	BW	Channel #	Freq (MHz)	% RB Allocation	RB Position	QPSK			16 QAM		
						Factory Upper Tolerance (dBm)	M P R	Measured Output Power (dBm)	Factory Upper Tolerance (dBm)	M P R	Measured Output Power (dBm)
LTE 13	10 MHz	23230	782	1RB Low	1 Pos 0	19.50	0	18.65	19.50	1	17.80
				1RB Mid	1 Pos 24	19.50	0	18.65	19.50	1	17.90
				1RB High	1 Pos 49	19.50	0	18.55	19.50	1	17.83
				50% RB Low	25 Pos 0	19.50	1	17.50	19.50	2	16.56
				50% RB Mid	25 Pos 12	19.50	1	17.58	19.50	2	16.65
				50% RB High	25 Pos 24	19.50	1	17.58	19.50	2	16.67
				100% RB	50 Pos 0	19.50	1	17.56	19.50	2	16.54
	5.0 MHz	23205	779.5	1RB Low	1 Pos 0	19.50	0	18.65	19.50	1	17.70
				1RB Mid	1 Pos 12	19.50	0	18.72	19.50	1	17.77
				1RB High	1 Pos 24	19.50	0	18.72	19.50	1	17.77
				50% RB Low	12 Pos 0	19.50	1	17.38	19.50	2	16.40
				50% RB Mid	12 Pos 6	19.50	1	17.54	19.50	2	16.52
				50% RB High	12 Pos 11	19.50	1	17.56	19.50	2	16.53
				100% RB	25 Pos 0	19.50	1	17.47	19.50	2	16.52
		23230	782	1RB Low	1 Pos 0	19.50	0	18.55	19.50	1	17.72
				1RB Mid	1 Pos 12	19.50	0	18.61	19.50	1	17.84
				1RB High	1 Pos 24	19.50	0	18.55	19.50	1	17.77
				50% RB Low	12 Pos 0	19.50	1	17.55	19.50	2	16.56
				50% RB Mid	12 Pos 6	19.50	1	17.52	19.50	2	16.56
				50% RB High	12 Pos 11	19.50	1	17.58	19.50	2	16.60
				100% RB	25 Pos 0	19.50	1	17.55	19.50	2	16.57
		23255	784.5	1RB Low	1 Pos 0	19.50	0	18.67	19.50	1	17.76
				1RB Mid	1 Pos 12	19.50	0	18.67	19.50	1	17.77
				1RB High	1 Pos 24	19.50	0	18.66	19.50	1	17.75
				50% RB Low	12 Pos 0	19.50	1	17.56	19.50	2	16.49
				50% RB Mid	12 Pos 6	19.50	1	17.54	19.50	2	16.49
				50% RB High	12 Pos 11	19.50	1	17.54	19.50	2	16.50
				100% RB	25 Pos 0	19.50	1	17.54	19.50	2	16.50

B.2.2.8 LTE Band 14 FDD Antenna Main 5

Band	BW	Channel #	Freq (MHz)	% RB Allocation	RB Position	QPSK			16 QAM		
						Factory Upper Tolerance (dBm)	M P R	Measured Output Power (dBm)	Factory Upper Tolerance (dBm)	M P R	Measured Output Power (dBm)
LTE 14	10 MHz	23330	793	1RB Low	1 Pos 0	19.50	0	18.62	19.50	1	17.84
				1RB Mid	1 Pos 24	19.50	0	18.56	19.50	1	17.86
				1RB High	1 Pos 49	19.50	0	18.55	19.50	1	17.81
				50% RB Low	25 Pos 0	19.50	1	17.52	19.50	2	16.61
				50% RB Mid	25 Pos 12	19.50	1	17.53	19.50	2	16.63
				50% RB High	25 Pos 24	19.50	1	17.61	19.50	2	16.69
				100% RB	50 Pos 0	19.50	1	17.59	19.50	2	16.58
	5.0 MHz	23305	790.5	1RB Low	1 Pos 0	19.50	0	18.68	19.50	1	17.76
				1RB Mid	1 Pos 12	19.50	0	18.66	19.50	1	17.78
				1RB High	1 Pos 24	19.50	0	18.67	19.50	1	17.84
				50% RB Low	12 Pos 0	19.50	1	17.50	19.50	2	16.49
				50% RB Mid	12 Pos 6	19.50	1	17.54	19.50	2	16.50
				50% RB High	12 Pos 11	19.50	1	17.57	19.50	2	16.52
				100% RB	25 Pos 0	19.50	1	17.56	19.50	2	16.59
		23330	793	1RB Low	1 Pos 0	19.50	0	18.54	19.50	1	17.76
				1RB Mid	1 Pos 12	19.50	0	18.58	19.50	1	17.82
				1RB High	1 Pos 24	19.50	0	18.52	19.50	1	17.76
				50% RB Low	12 Pos 0	19.50	1	17.55	19.50	2	16.54
				50% RB Mid	12 Pos 6	19.50	1	17.54	19.50	2	16.56
				50% RB High	12 Pos 11	19.50	1	17.53	19.50	2	16.55
				100% RB	25 Pos 0	19.50	1	17.55	19.50	2	16.57
		23355	795.5	1RB Low	1 Pos 0	19.50	0	18.60	19.50	1	17.67
				1RB Mid	1 Pos 12	19.50	0	18.63	19.50	1	17.74
				1RB High	1 Pos 24	19.50	0	18.61	19.50	1	17.65
				50% RB Low	12 Pos 0	19.50	1	17.54	19.50	2	16.49
				50% RB Mid	12 Pos 6	19.50	1	17.54	19.50	2	16.49
				50% RB High	12 Pos 11	19.50	1	17.57	19.50	2	16.48
				100% RB	25 Pos 0	19.50	1	17.53	19.50	2	16.50

B.2.2.9 LTE Band 17 FDD Antenna Main 5 & Antenna Aux 8

SAR Measurement for LTE Band 17 FDD (Frequency range: 704 – 716MHz) is covered by LTE Band 12 FDD (Frequency range: 699 – 716MHz) due to overlapping frequency range, same maximum tune-up and same bandwidth.

B.2.2.10 LTE Band 25 FDD Antenna Main 5

Band	BW	Channel #	Freq (MHz)	% RB Allocation	RB Position	QPSK			16 QAM		
						Factory Upper Tolerance (dBm)	M P R	Measured Output Power (dBm)	Factory Upper Tolerance (dBm)	M P R	Measured Output Power (dBm)
LTE 25	20 MHz	26140	1860.0	1RB Low	1 Pos 0	16.50	0	15.99	16.50	1	15.08
				1RB Mid	1 Pos 50	16.50	0	16.09	16.50	1	15.23
				1RB High	1 Pos 99	16.50	0	15.93	16.50	1	15.13
				50% RB Low	50 Pos 0	16.50	1	15.09	16.50	2	14.14
				50% RB Mid	50 Pos 24	16.50	1	15.07	16.50	2	14.14
				50% RB High	50 Pos 50	16.50	1	14.96	16.50	2	14.03
		100% RB	100 Pos 0	16.50	1	15.07	16.50	2	14.10		
		26365	1882.5	1RB Low	1 Pos 0	16.50	0	15.97	16.50	1	14.82
				1RB Mid	1 Pos 50	16.50	0	15.98	16.50	1	14.88
				1RB High	1 Pos 99	16.50	0	15.87	16.50	1	14.76
				50% RB Low	50 Pos 0	16.50	1	14.92	16.50	2	14.05
				50% RB Mid	50 Pos 24	16.50	1	15.10	16.50	2	14.18
				50% RB High	50 Pos 50	16.50	1	14.97	16.50	2	14.05
		100% RB	100 Pos 0	16.50	1	14.92	16.50	2	13.98		
		26590	1905.0	1RB Low	1 Pos 0	16.50	0	15.97	16.50	1	14.77
				1RB Mid	1 Pos 50	16.50	0	16.10	16.50	1	14.95
				1RB High	1 Pos 99	16.50	0	16.04	16.50	1	14.89
				50% RB Low	50 Pos 0	16.50	1	15.00	16.50	2	14.02
	50% RB Mid			50 Pos 24	16.50	1	15.10	16.50	2	14.09	
	50% RB High			50 Pos 50	16.50	1	14.97	16.50	2	14.03	
	100% RB	100 Pos 0	16.50	1	14.98	16.50	2	14.04			
	15 MHz	26115	1857.5	1RB Low	1 Pos 0	16.50	0	15.99	16.50	1	15.27
				1RB Mid	1 Pos 38	16.50	0	15.91	16.50	1	15.22
				1RB High	1 Pos 74	16.50	0	16.09	16.50	1	15.39
				50% RB Low	38 Pos 0	16.50	1	15.00	16.50	2	14.11
				50% RB Mid	38 Pos 19	16.50	1	15.03	16.50	2	14.07
				50% RB High	38 Pos 39	16.50	1	14.94	16.50	2	14.00
		100% RB	75 Pos 0	16.50	1	14.95	16.50	2	14.09		
		26365	1882.5	1RB Low	1 Pos 0	16.50	0	16.11	16.50	1	15.04
				1RB Mid	1 Pos 38	16.50	0	16.01	16.50	1	14.94
				1RB High	1 Pos 74	16.50	0	16.12	16.50	1	15.15
				50% RB Low	38 Pos 0	16.50	1	14.98	16.50	2	14.04
				50% RB Mid	38 Pos 19	16.50	1	15.03	16.50	2	14.07
				50% RB High	38 Pos 39	16.50	1	14.95	16.50	2	14.04
		100% RB	75 Pos 0	16.50	1	14.98	16.50	2	14.08		
		26615	1907.5	1RB Low	1 Pos 0	16.50	0	15.91	16.50	1	15.05
				1RB Mid	1 Pos 38	16.50	0	15.95	16.50	1	15.09
				1RB High	1 Pos 74	16.50	0	15.99	16.50	1	15.07
				50% RB Low	38 Pos 0	16.50	1	15.03	16.50	2	14.16
	50% RB Mid			38 Pos 19	16.50	1	15.06	16.50	2	14.17	
	50% RB High			38 Pos 39	16.50	1	15.01	16.50	2	14.11	
	100% RB	75 Pos 0	16.50	1	15.03	16.50	2	14.12			
	10 MHz	26090	1855.0	1RB Low	1 Pos 0	16.50	0	16.05	16.50	1	15.33
				1RB Mid	1 Pos 24	16.50	0	16.09	16.50	1	15.31
				1RB High	1 Pos 49	16.50	0	16.07	16.50	1	15.32
				50% RB Low	25 Pos 0	16.50	1	15.00	16.50	2	14.13
				50% RB Mid	25 Pos 12	16.50	1	15.02	16.50	2	14.17
				50% RB High	25 Pos 25	16.50	1	14.98	16.50	2	14.11
100% RB		50 Pos0	16.50	1	15.01	16.50	2	14.09			
26365		1882.5	1RB Low	1 Pos 0	16.50	0	16.14	16.50	1	14.99	
			1RB Mid	1 Pos 24	16.50	0	16.11	16.50	1	15.03	
			1RB High	1 Pos 49	16.50	0	16.11	16.50	1	14.95	
			50% RB Low	25 Pos 0	16.50	1	15.00	16.50	2	14.11	
			50% RB Mid	25 Pos 12	16.50	1	15.07	16.50	2	14.16	
			50% RB High	25 Pos 25	16.50	1	15.05	16.50	2	14.17	
100% RB		50 Pos0	16.50	1	15.06	16.50	2	14.14			
26640		1910.0	1RB Low	1 Pos 0	16.50	0	16.01	16.50	1	15.07	
			1RB Mid	1 Pos 24	16.50	0	16.03	16.50	1	15.11	
			1RB High	1 Pos 49	16.50	0	16.06	16.50	1	15.16	
			50% RB Low	25 Pos 0	16.50	1	15.09	16.50	2	14.24	
	50% RB Mid		25 Pos 12	16.50	1	15.03	16.50	2	14.17		
	50% RB High		25 Pos 25	16.50	1	15.02	16.50	2	14.13		
100% RB	50 Pos0	16.50	1	15.09	16.50	2	14.13				

Band	BW	Channel #	Freq (MHz)	% RB Allocation	RB Position	QPSK			16 QAM		
						Factory Upper Tolerance (dBm)	M P R	Measured Output Power (dBm)	Factory Upper Tolerance (dBm)	M P R	Measured Output Power (dBm)
LTE25	5 MHz	26065	1852.5	1RB Low	1 Pos 0	16.50	0	16.13	16.50	1	15.23
				1RB Mid	1 Pos 38	16.50	0	16.16	16.50	1	15.26
				1RB High	1 Pos 74	16.50	0	16.14	16.50	1	15.22
				50% RB Low	38 Pos 0	16.50	1	14.99	16.50	2	14.06
				50% RB Mid	38 Pos 19	16.50	1	15.01	16.50	2	14.05
				50% RB High	38 Pos 39	16.50	1	15.03	16.50	2	14.11
		100% RB	75 Pos 0	16.50	1	15.00	16.50	2	14.13		
		26365	1882.5	1RB Low	1 Pos 0	16.50	0	16.06	16.50	1	15.24
				1RB Mid	1 Pos 38	16.50	0	16.05	16.50	1	15.29
				1RB High	1 Pos 74	16.50	0	16.04	16.50	1	15.23
				50% RB Low	38 Pos 0	16.50	1	14.98	16.50	2	14.15
				50% RB Mid	38 Pos 19	16.50	1	15.00	16.50	2	14.15
				50% RB High	38 Pos 39	16.50	1	14.97	16.50	2	14.12
		100% RB	75 Pos 0	16.50	1	15.03	16.50	2	14.12		
		26665	1912.5	1RB Low	1 Pos 0	16.50	0	16.15	16.50	1	15.28
				1RB Mid	1 Pos 38	16.50	0	16.17	16.50	1	15.30
				1RB High	1 Pos 74	16.50	0	16.23	16.50	1	15.32
				50% RB Low	38 Pos 0	16.50	1	15.15	16.50	2	14.16
	50% RB Mid			38 Pos 19	16.50	1	15.10	16.50	2	14.11	
	50% RB High			38 Pos 39	16.50	1	15.10	16.50	2	14.12	
	100% RB	75 Pos 0	16.50	1	15.09	16.50	2	14.14			
	3 MHz	26055	1851.5	1RB Low	1 Pos 0	16.50	0	16.03	16.50	1	15.31
				1RB Mid	1 Pos 24	16.50	0	16.08	16.50	1	15.35
				1RB High	1 Pos 49	16.50	0	16.03	16.50	1	15.32
				50% RB Low	25 Pos 0	16.50	1	14.97	16.50	2	14.09
				50% RB Mid	25 Pos 12	16.50	1	14.97	16.50	2	14.11
				50% RB High	25 Pos 24	16.50	1	14.97	16.50	2	14.11
		100% RB	50 Pos 0	16.50	1	14.97	16.50	2	14.07		
		26365	1882.5	1RB Low	1 Pos 0	16.50	0	16.08	16.50	1	15.32
				1RB Mid	1 Pos 24	16.50	0	16.13	16.50	1	15.33
				1RB High	1 Pos 49	16.50	0	16.03	16.50	1	15.29
				50% RB Low	25 Pos 0	16.50	1	14.97	16.50	2	14.08
				50% RB Mid	25 Pos 12	16.50	1	14.93	16.50	2	14.06
				50% RB High	25 Pos 24	16.50	1	14.92	16.50	2	14.05
		100% RB	50 Pos 0	16.50	1	14.96	16.50	2	14.03		
		26675	1913.5	1RB Low	1 Pos 0	16.50	0	16.11	16.50	1	15.37
				1RB Mid	1 Pos 24	16.50	0	16.15	16.50	1	15.43
				1RB High	1 Pos 49	16.50	0	16.08	16.50	1	15.38
				50% RB Low	25 Pos 0	16.50	1	15.05	16.50	2	14.15
	50% RB Mid			25 Pos 12	16.50	1	15.08	16.50	2	14.19	
	50% RB High			25 Pos 24	16.50	1	15.05	16.50	2	14.16	
	100% RB	50 Pos 0	16.50	1	15.09	16.50	2	14.15			
	1.4 MHz	26047	1850.7	1RB Low	1 Pos 0	16.50	0	16.07	16.50	1	14.95
				1RB Mid	1 Pos 12	16.50	0	16.08	16.50	1	15.03
				1RB High	1 Pos 24	16.50	0	16.01	16.50	1	14.95
				50% RB Low	12 Pos 0	16.50	1	15.98	16.50	1	15.18
				50% RB Mid	12 Pos 6	16.50	1	16.00	16.50	1	15.20
				50% RB High	12 Pos 11	16.50	1	15.98	16.50	1	15.22
		100% RB	25 Pos 0	16.50	1	15.01	16.50	2	14.15		
		26365	1882.5	1RB Low	1 Pos 0	16.50	0	15.97	16.50	1	14.87
				1RB Mid	1 Pos 12	16.50	0	16.02	16.50	1	14.96
				1RB High	1 Pos 24	16.50	0	15.97	16.50	1	14.87
				50% RB Low	12 Pos 0	16.50	1	15.97	16.50	1	15.18
				50% RB Mid	12 Pos 6	16.50	1	15.97	16.50	1	15.20
				50% RB High	12 Pos 11	16.50	1	15.96	16.50	1	15.17
		100% RB	25 Pos 0	16.50	1	14.99	16.50	2	14.15		
		26683	1914.3	1RB Low	1 Pos 0	16.50	0	16.09	16.50	1	15.02
				1RB Mid	1 Pos 12	16.50	0	16.12	16.50	1	15.08
				1RB High	1 Pos 24	16.50	0	16.06	16.50	1	14.99
				50% RB Low	12 Pos 0	16.50	1	16.05	16.50	1	15.25
	50% RB Mid			12 Pos 6	16.50	1	16.08	16.50	1	15.24	
	50% RB High			12 Pos 11	16.50	1	16.08	16.50	1	15.29	
	100% RB	25 Pos 0	16.50	1	15.08	16.50	2	14.21			

B.2.2.11 LTE Band 25 FDD Antenna Aux 8

Band	BW	Channel #	Freq (MHz)	% RB Allocation	RB Position	QPSK			16 QAM		
						Factory Upper Tolerance (dBm)	M P R	Measured Output Power (dBm)	Factory Upper Tolerance (dBm)	M P R	Measured Output Power (dBm)
LTE 25	20 MHz	26140	1860.0	1RB Low	1 Pos 0	19.00	0	17.86	19.00	1	17.42
				1RB Mid	1 Pos 50	19.00	0	17.88	19.00	1	17.50
				1RB High	1 Pos 99	19.00	0	17.76	19.00	1	17.32
				50% RB Low	50 Pos 0	19.00	1	16.81	19.00	2	15.78
				50% RB Mid	50 Pos 24	19.00	1	16.96	19.00	2	15.91
				50% RB High	50 Pos 50	19.00	1	16.86	19.00	2	15.84
		100% RB	100 Pos 0	19.00	1	16.84	19.00	2	15.81		
		26365	1882.5	1RB Low	1 Pos 0	19.00	0	17.80	19.00	1	17.08
				1RB Mid	1 Pos 50	19.00	0	17.94	19.00	1	17.22
				1RB High	1 Pos 99	19.00	0	17.80	19.00	1	17.11
				50% RB Low	50 Pos 0	19.00	1	16.85	19.00	2	15.82
				50% RB Mid	50 Pos 24	19.00	1	16.90	19.00	2	15.89
				50% RB High	50 Pos 50	19.00	1	16.82	19.00	2	15.79
		100% RB	100 Pos 0	19.00	1	16.85	19.00	2	15.85		
		26590	1905.0	1RB Low	1 Pos 0	19.00	0	17.81	19.00	1	16.99
				1RB Mid	1 Pos 50	19.00	0	17.92	19.00	1	17.11
				1RB High	1 Pos 99	19.00	0	17.89	19.00	1	17.05
				50% RB Low	50 Pos 0	19.00	1	16.89	19.00	2	15.86
	50% RB Mid			50 Pos 24	19.00	1	16.96	19.00	2	15.86	
	50% RB High			50 Pos 50	19.00	1	16.80	19.00	2	15.77	
	100% RB	100 Pos 0	19.00	1	16.81	19.00	2	15.82			
	15 MHz	26115	1857.5	1RB Low	1 Pos 0	19.00	0	17.82	19.00	1	17.27
				1RB Mid	1 Pos 38	19.00	0	17.73	19.00	1	17.14
				1RB High	1 Pos 74	19.00	0	17.82	19.00	1	17.23
				50% RB Low	38 Pos 0	19.00	1	16.85	19.00	2	15.84
				50% RB Mid	38 Pos 19	19.00	1	16.88	19.00	2	15.87
				50% RB High	38 Pos 39	19.00	1	16.82	19.00	2	15.87
		100% RB	75 Pos 0	19.00	1	16.82	19.00	2	15.80		
		26365	1882.5	1RB Low	1 Pos 0	19.00	0	17.77	19.00	1	17.37
				1RB Mid	1 Pos 38	19.00	0	17.74	19.00	1	17.37
				1RB High	1 Pos 74	19.00	0	17.84	19.00	1	17.43
				50% RB Low	38 Pos 0	19.00	1	16.79	19.00	2	15.86
				50% RB Mid	38 Pos 19	19.00	1	16.85	19.00	2	15.88
				50% RB High	38 Pos 39	19.00	1	16.82	19.00	2	15.84
		100% RB	75 Pos 0	19.00	1	16.83	19.00	2	15.80		
		26615	1907.5	1RB Low	1 Pos 0	19.00	0	17.81	19.00	1	16.95
				1RB Mid	1 Pos 38	19.00	0	17.83	19.00	1	16.98
				1RB High	1 Pos 74	19.00	0	17.85	19.00	1	16.99
				50% RB Low	38 Pos 0	19.00	1	16.88	19.00	2	15.87
	50% RB Mid			38 Pos 19	19.00	1	16.92	19.00	2	15.88	
	50% RB High			38 Pos 39	19.00	1	16.85	19.00	2	15.83	
	100% RB	75 Pos 0	19.00	1	16.88	19.00	2	15.87			
	10 MHz	26090	1855.0	1RB Low	1 Pos 0	19.00	0	17.91	19.00	1	16.89
				1RB Mid	1 Pos 24	19.00	0	17.92	19.00	1	16.89
				1RB High	1 Pos 49	19.00	0	17.86	19.00	1	16.86
				50% RB Low	25 Pos 0	19.00	1	16.85	19.00	2	15.94
				50% RB Mid	25 Pos 12	19.00	1	16.91	19.00	2	15.99
				50% RB High	25 Pos 25	19.00	1	16.94	19.00	2	16.01
100% RB		50 Pos0	19.00	1	16.89	19.00	2	15.90			
26365		1882.5	1RB Low	1 Pos 0	19.00	0	17.86	19.00	1	17.40	
			1RB Mid	1 Pos 24	19.00	0	17.84	19.00	1	17.40	
			1RB High	1 Pos 49	19.00	0	17.85	19.00	1	17.42	
			50% RB Low	25 Pos 0	19.00	1	16.80	19.00	2	15.87	
			50% RB Mid	25 Pos 12	19.00	1	16.85	19.00	2	15.91	
			50% RB High	25 Pos 25	19.00	1	16.80	19.00	2	15.85	
100% RB		50 Pos0	19.00	1	16.85	19.00	2	15.83			
26640		1910.0	1RB Low	1 Pos 0	19.00	0	17.82	19.00	1	16.98	
			1RB Mid	1 Pos 24	19.00	0	17.89	19.00	1	17.03	
			1RB High	1 Pos 49	19.00	0	17.90	19.00	1	17.02	
			50% RB Low	25 Pos 0	19.00	1	16.91	19.00	2	15.95	
	50% RB Mid		25 Pos 12	19.00	1	16.90	19.00	2	15.92		
	50% RB High		25 Pos 25	19.00	1	16.83	19.00	2	15.85		
100% RB	50 Pos0	19.00	1	16.89	19.00	2	15.86				

Band	BW	Channel #	Freq (MHz)	% RB Allocation	RB Position	QPSK			16 QAM		
						Factory Upper Tolerance (dBm)	M P R	Measured Output Power (dBm)	Factory Upper Tolerance (dBm)	M P R	Measured Output Power (dBm)
TE25	5 MHz	26065	1852.5	1RB Low	1 Pos 0	19.00	0	17.95	19.00	1	16.75
				1RB Mid	1 Pos 38	19.00	0	18.06	19.00	1	16.78
				1RB High	1 Pos 74	19.00	0	17.95	19.00	1	16.72
				50% RB Low	38 Pos 0	19.00	1	16.78	19.00	2	15.77
				50% RB Mid	38 Pos 19	19.00	1	16.83	19.00	2	15.79
				50% RB High	38 Pos 39	19.00	1	16.83	19.00	2	15.83
		100% RB	75 Pos 0	19.00	1	16.80	19.00	2	15.86		
		26365	1882.5	1RB Low	1 Pos 0	19.00	0	17.97	19.00	1	16.98
				1RB Mid	1 Pos 38	19.00	0	17.94	19.00	1	16.92
				1RB High	1 Pos 74	19.00	0	17.95	19.00	1	16.94
				50% RB Low	38 Pos 0	19.00	1	16.88	19.00	2	15.82
				50% RB Mid	38 Pos 19	19.00	1	16.87	19.00	2	15.83
				50% RB High	38 Pos 39	19.00	1	16.87	19.00	2	15.80
		100% RB	75 Pos 0	19.00	1	16.85	19.00	2	15.90		
		26665	1912.5	1RB Low	1 Pos 0	19.00	0	17.91	19.00	1	17.18
				1RB Mid	1 Pos 38	19.00	0	17.95	19.00	1	17.19
				1RB High	1 Pos 74	19.00	0	17.98	19.00	1	17.22
				50% RB Low	38 Pos 0	19.00	1	16.94	19.00	2	15.92
	50% RB Mid			38 Pos 19	19.00	1	16.92	19.00	2	15.91	
	50% RB High			38 Pos 39	19.00	1	16.89	19.00	2	15.89	
	100% RB	75 Pos 0	19.00	1	16.91	19.00	2	15.91			
	3 MHz	26055	1851.5	1RB Low	1 Pos 0	19.00	0	17.79	19.00	1	17.40
				1RB Mid	1 Pos 24	19.00	0	17.80	19.00	1	17.32
				1RB High	1 Pos 49	19.00	0	17.80	19.00	1	17.34
				50% RB Low	25 Pos 0	19.00	1	16.76	19.00	2	15.95
				50% RB Mid	25 Pos 12	19.00	1	16.79	19.00	2	15.95
				50% RB High	25 Pos 24	19.00	1	16.79	19.00	2	15.95
		100% RB	50 Pos 0	19.00	1	16.77	19.00	2	15.83		
		26365	1882.5	1RB Low	1 Pos 0	19.00	0	17.88	19.00	1	17.38
				1RB Mid	1 Pos 24	19.00	0	17.85	19.00	1	17.36
				1RB High	1 Pos 49	19.00	0	17.82	19.00	1	17.34
				50% RB Low	25 Pos 0	19.00	1	16.78	19.00	2	15.99
				50% RB Mid	25 Pos 12	19.00	1	16.77	19.00	2	15.96
				50% RB High	25 Pos 24	19.00	1	16.76	19.00	2	15.96
		100% RB	50 Pos 0	19.00	1	16.79	19.00	2	15.86		
		26675	1913.5	1RB Low	1 Pos 0	19.00	0	17.90	19.00	1	17.42
				1RB Mid	1 Pos 24	19.00	0	17.91	19.00	1	17.43
				1RB High	1 Pos 49	19.00	0	17.90	19.00	1	17.41
				50% RB Low	25 Pos 0	19.00	1	16.87	19.00	2	16.07
	50% RB Mid			25 Pos 12	19.00	1	16.90	19.00	2	16.08	
	50% RB High			25 Pos 24	19.00	1	16.88	19.00	2	16.05	
	100% RB	50 Pos 0	19.00	1	16.90	19.00	2	15.96			
	1.4 MHz	26047	1850.7	1RB Low	1 Pos 0	19.00	0	17.77	19.00	1	16.81
				1RB Mid	1 Pos 12	19.00	0	17.76	19.00	1	16.80
				1RB High	1 Pos 24	19.00	0	17.80	19.00	1	16.83
				50% RB Low	12 Pos 0	19.00	1	17.82	19.00	1	16.96
				50% RB Mid	12 Pos 6	19.00	1	17.86	19.00	1	16.99
				50% RB High	12 Pos 11	19.00	1	17.84	19.00	1	16.97
100% RB		25 Pos 0	19.00	1	16.83	19.00	2	15.79			
26365		1882.5	1RB Low	1 Pos 0	19.00	0	17.82	19.00	1	16.88	
			1RB Mid	1 Pos 12	19.00	0	17.79	19.00	1	16.85	
			1RB High	1 Pos 24	19.00	0	17.81	19.00	1	16.86	
			50% RB Low	12 Pos 0	19.00	1	17.86	19.00	1	17.01	
			50% RB Mid	12 Pos 6	19.00	1	17.89	19.00	1	17.03	
			50% RB High	12 Pos 11	19.00	1	17.82	19.00	1	17.01	
100% RB		25 Pos 0	19.00	1	16.84	19.00	2	15.83			
26683		1914.3	1RB Low	1 Pos 0	19.00	0	17.85	19.00	1	16.93	
			1RB Mid	1 Pos 12	19.00	0	17.84	19.00	1	16.93	
			1RB High	1 Pos 24	19.00	0	17.84	19.00	1	16.94	
			50% RB Low	12 Pos 0	19.00	1	17.94	19.00	1	17.08	
	50% RB Mid		12 Pos 6	19.00	1	17.96	19.00	1	17.08		
	50% RB High		12 Pos 11	19.00	1	17.92	19.00	1	17.08		
100% RB	25 Pos 0	19.00	1	16.93	19.00	2	15.90				

B.2.2.12 LTE Band 26 FDD Antenna Main 5

Band	BW	Channel #	Freq (MHz)	% RB Allocation	RB Position	QPSK			16 QAM		
						Factory Upper Tolerance (dBm)	M P R	Measured Output Power (dBm)	Factory Upper Tolerance (dBm)	M P R	Measured Output Power (dBm)
LTE26	15 MHz	26775	821.5	1RB Low	1 Pos 0	20.00	0	19.48	20.00	1	18.80
				1RB Mid	1 Pos 38	20.00	0	19.52	20.00	1	18.79
				1RB High	1 Pos 74	20.00	0	19.47	20.00	1	18.73
				50% RB Low	38 Pos 0	20.00	1	18.58	20.00	2	17.56
				50% RB Mid	38 Pos 19	20.00	1	18.51	20.00	2	17.54
				50% RB High	38 Pos 39	20.00	1	18.49	20.00	2	17.56
		100% RB	75 Pos 0	20.00	1	18.57	20.00	2	17.55		
		26865	831.5	1RB Low	1 Pos 0	20.00	0	19.49	20.00	1	18.52
				1RB Mid	1 Pos 38	20.00	0	19.61	20.00	1	18.59
				1RB High	1 Pos 74	20.00	0	19.47	20.00	1	18.52
				50% RB Low	38 Pos 0	20.00	1	18.49	20.00	2	17.43
				50% RB Mid	38 Pos 19	20.00	1	18.52	20.00	2	17.47
				50% RB High	38 Pos 39	20.00	1	18.44	20.00	2	17.40
		100% RB	75 Pos 0	20.00	1	18.51	20.00	2	17.50		
		26965	841.5	1RB Low	1 Pos 0	20.00	0	19.44	20.00	1	18.63
				1RB Mid	1 Pos 38	20.00	0	19.51	20.00	1	18.65
				1RB High	1 Pos 74	20.00	0	19.38	20.00	1	18.54
				50% RB Low	38 Pos 0	20.00	1	18.54	20.00	2	17.56
	50% RB Mid			38 Pos 19	20.00	1	18.48	20.00	2	17.52	
	50% RB High			38 Pos 39	20.00	1	18.48	20.00	2	17.53	
	100% RB	75 Pos 0	20.00	1	18.56	20.00	2	17.52			
	10 MHz	26750	820	1RB Low	1 Pos 0	20.00	0	19.53	20.00	1	18.82
				1RB Mid	1 Pos 24	20.00	0	19.52	20.00	1	18.81
				1RB High	1 Pos 49	20.00	0	19.44	20.00	1	18.75
				50% RB Low	25 Pos 0	20.00	1	18.58	20.00	2	17.68
				50% RB Mid	25 Pos 12	20.00	1	18.56	20.00	2	17.62
				50% RB High	25 Pos 24	20.00	1	18.53	20.00	2	17.61
		100% RB	50 Pos 0	20.00	1	18.57	20.00	2	17.56		
		26865	831.5	1RB Low	1 Pos 0	20.00	0	19.59	20.00	1	18.37
				1RB Mid	1 Pos 24	20.00	0	19.57	20.00	1	18.41
				1RB High	1 Pos 49	20.00	0	19.54	20.00	1	18.37
				50% RB Low	25 Pos 0	20.00	1	18.49	20.00	2	17.51
				50% RB Mid	25 Pos 12	20.00	1	18.51	20.00	2	17.53
				50% RB High	25 Pos 24	20.00	1	18.47	20.00	2	17.48
		100% RB	50 Pos 0	20.00	1	18.55	20.00	2	17.51		
		26990	844	1RB Low	1 Pos 0	20.00	0	19.44	20.00	1	18.62
				1RB Mid	1 Pos 24	20.00	0	19.52	20.00	1	18.69
				1RB High	1 Pos 49	20.00	0	19.46	20.00	1	18.65
				50% RB Low	25 Pos 0	20.00	1	18.48	20.00	2	17.55
	50% RB Mid			25 Pos 12	20.00	1	18.48	20.00	2	17.54	
	50% RB High			25 Pos 24	20.00	1	18.52	20.00	2	17.50	
	100% RB	50 Pos 0	20.00	1	18.54	20.00	2	17.48			
	5.0 MHz	26715	816.5	1RB Low	1 Pos 0	20.00	0	19.56	20.00	1	18.82
				1RB Mid	1 Pos 12	20.00	0	19.59	20.00	1	18.87
				1RB High	1 Pos 24	20.00	0	19.63	20.00	1	18.89
				50% RB Low	12 Pos 0	20.00	1	18.61	20.00	2	17.55
				50% RB Mid	12 Pos 6	20.00	1	18.54	20.00	2	17.56
				50% RB High	12 Pos 11	20.00	1	18.52	20.00	2	17.51
100% RB		25 Pos 0	20.00	1	18.58	20.00	2	17.60			
26865		831.5	1RB Low	1 Pos 0	20.00	0	19.54	20.00	1	18.81	
			1RB Mid	1 Pos 12	20.00	0	19.51	20.00	1	18.76	
			1RB High	1 Pos 24	20.00	0	19.50	20.00	1	18.75	
			50% RB Low	12 Pos 0	20.00	1	18.59	20.00	2	17.57	
			50% RB Mid	12 Pos 6	20.00	1	18.51	20.00	2	17.55	
			50% RB High	12 Pos 11	20.00	1	18.46	20.00	2	17.50	
100% RB		25 Pos 0	20.00	1	18.54	20.00	2	17.54			
27015		846.5	1RB Low	1 Pos 0	20.00	0	19.47	20.00	1	18.71	
			1RB Mid	1 Pos 12	20.00	0	19.50	20.00	1	18.71	
			1RB High	1 Pos 24	20.00	0	19.57	20.00	1	18.69	
			50% RB Low	12 Pos 0	20.00	1	18.48	20.00	2	17.44	
	50% RB Mid		12 Pos 6	20.00	1	18.46	20.00	2	17.43		
	50% RB High		12 Pos 11	20.00	1	18.47	20.00	2	17.39		
100% RB	25 Pos 0	20.00	1	18.52	20.00	2	17.48				

Band	BW	Channel #	Freq (MHz)	% RB Allocation	RB Position	QPSK			16 QAM			
						Factory Upper Tolerance (dBm)	M P R	Measured Output Power (dBm)	Factory Upper Tolerance (dBm)	M P R	Measured Output Power (dBm)	
LTE26	3.0 MHz	26705	815.5	1RB Low	1 Pos 0	20.00	0	19.48	20.00	1	18.84	
				1RB Mid	1 Pos 7	20.00	0	19.50	20.00	1	18.79	
				1RB High	1 Pos 14	20.00	0	19.52	20.00	1	18.80	
				50% RB Low	8 Pos 0	20.00	1	18.51	20.00	2	17.53	
				50% RB Mid	8 Pos 4	20.00	1	18.51	20.00	2	17.49	
				50% RB High	8 Pos 7	20.00	1	18.53	20.00	2	17.45	
		100% RB	15 Pos 0	20.00	1	18.52	20.00	2	17.53			
		26865	831.5	1RB Low	1 Pos 0	20.00	0	19.48	20.00	1	18.80	
				1RB Mid	1 Pos 7	20.00	0	19.48	20.00	1	18.77	
				1RB High	1 Pos 14	20.00	0	19.45	20.00	1	18.73	
				50% RB Low	8 Pos 0	20.00	1	18.49	20.00	2	17.53	
				50% RB Mid	8 Pos 4	20.00	1	18.48	20.00	2	17.49	
				50% RB High	8 Pos 7	20.00	1	18.52	20.00	2	17.50	
		100% RB	15 Pos 0	20.00	1	18.51	20.00	2	17.49			
		27025	847.5	1RB Low	1 Pos 0	20.00	0	19.41	20.00	1	18.76	
				1RB Mid	1 Pos 7	20.00	0	19.46	20.00	1	18.77	
				1RB High	1 Pos 14	20.00	0	19.43	20.00	1	18.76	
				50% RB Low	8 Pos 0	20.00	1	18.49	20.00	2	17.51	
				50% RB Mid	8 Pos 4	20.00	1	18.47	20.00	2	17.50	
				50% RB High	8 Pos 7	20.00	1	18.41	20.00	2	17.48	
		100% RB	15 Pos 0	20.00	1	18.49	20.00	2	17.44			
		1.4 MHz	26697	814.7	1RB Low	1 Pos 0	20.00	0	19.54	20.00	1	18.47
					1RB Mid	1 Pos 2	20.00	0	19.63	20.00	1	18.58
					1RB High	1 Pos 5	20.00	0	19.57	20.00	1	18.55
	50% RB Low				3 Pos 0	20.00	1	19.50	20.00	1	18.71	
	50% RB Mid				3 Pos 1	20.00	1	19.53	20.00	1	18.69	
	50% RB High				3 Pos 2	20.00	1	19.52	20.00	1	18.69	
	100% RB			6 Pos 0	20.00	1	18.51	20.00	2	17.59		
	26865			831.5	1RB Low	1 Pos 0	20.00	0	19.45	20.00	1	18.50
					1RB Mid	1 Pos 2	20.00	0	19.40	20.00	1	18.56
					1RB High	1 Pos 5	20.00	0	19.42	20.00	1	18.50
					50% RB Low	3 Pos 0	20.00	1	19.34	20.00	1	18.66
					50% RB Mid	3 Pos 1	20.00	1	19.35	20.00	1	18.64
			50% RB High		3 Pos 2	20.00	1	19.32	20.00	1	18.64	
	100% RB		6 Pos 0	20.00	1	18.48	20.00	2	17.56			
	27033		848.3	1RB Low	1 Pos 0	20.00	0	19.31	20.00	1	18.42	
				1RB Mid	1 Pos 2	20.00	0	19.33	20.00	1	18.46	
				1RB High	1 Pos 5	20.00	0	19.28	20.00	1	18.39	
				50% RB Low	3 Pos 0	20.00	1	19.27	20.00	1	18.63	
				50% RB Mid	3 Pos 1	20.00	1	19.29	20.00	1	18.62	
				50% RB High	3 Pos 2	20.00	1	19.29	20.00	1	18.63	
	100% RB		6 Pos 0	20.00	1	18.43	20.00	2	17.57			

B.2.2.13 LTE Band 30 FDD Antenna Main 5

Band	BW	Channel #	Freq (MHz)	% RB Allocation	RB Position	QPSK			16 QAM		
						Factory Upper Tolerance (dBm)	M P R	Measured Output Power (dBm)	Factory Upper Tolerance (dBm)	M P R	Measured Output Power (dBm)
LTE30	10 MHz	27710	2310	1RB Low	1 Pos 0	17.00	0	16.38	17.00	1	15.18
				1RB Mid	1 Pos 24	17.00	0	16.46	17.00	1	15.29
				1RB High	1 Pos 49	17.00	0	16.41	17.00	1	15.23
				50% RB Low	25 Pos 0	17.00	1	15.22	17.00	2	14.20
				50% RB Mid	25 Pos 12	17.00	1	15.33	17.00	2	14.35
				50% RB High	25 Pos 24	17.00	1	15.19	17.00	2	14.25
				100% RB	50 Pos 0	17.00	1	15.25	17.00	2	14.19
	5.0 MHz	27710	2310	1RB Low	1 Pos 0	17.00	0	15.98	17.00	1	15.19
				1RB Mid	1 Pos 12	17.00	0	15.98	17.00	1	15.18
				1RB High	1 Pos 24	17.00	0	15.97	17.00	1	15.17
				50% RB Low	12 Pos 0	17.00	1	14.84	17.00	2	13.81
				50% RB Mid	12 Pos 6	17.00	1	14.84	17.00	2	13.79
				50% RB High	12 Pos 11	17.00	1	14.80	17.00	2	13.75
				100% RB	25 Pos 0	17.00	1	14.83	17.00	2	13.84

B.2.2.14 LTE Band 30 FDD Antenna Aux 8

Band	BW	Channel #	Freq (MHz)	% RB Allocation	RB Position	QPSK			16 QAM		
						Factory Upper Tolerance (dBm)	M P R	Measured Output Power (dBm)	Factory Upper Tolerance (dBm)	M P R	Measured Output Power (dBm)
LTE30	10 MHz	27710	2310	1RB Low	1 Pos 0	16.50	0	16.07	16.50	1	14.84
				1RB Mid	1 Pos 24	16.50	0	16.11	16.50	1	14.94
				1RB High	1 Pos 49	16.50	0	16.04	16.50	1	14.86
				50% RB Low	25 Pos 0	16.50	1	14.90	16.50	2	13.87
				50% RB Mid	25 Pos 12	16.50	1	14.98	16.50	2	13.98
				50% RB High	25 Pos 24	16.50	1	14.81	16.50	2	13.84
				100% RB	50 Pos 0	16.50	1	14.91	16.50	2	13.88
	5.0 MHz	27710	2310	1RB Low	1 Pos 0	16.50	0	16.07	16.50	1	15.29
				1RB Mid	1 Pos 12	16.50	0	16.08	16.50	1	15.26
				1RB High	1 Pos 24	16.50	0	16.05	16.50	1	15.26
				50% RB Low	12 Pos 0	16.50	1	14.98	16.50	2	13.87
				50% RB Mid	12 Pos 6	16.50	1	14.98	16.50	2	13.90
				50% RB High	12 Pos 11	16.50	1	14.93	16.50	2	13.86
				100% RB	25 Pos 0	16.50	1	14.92	16.50	2	13.92

B.2.2.15 LTE Band 41 TDD Antenna Main 5

Band	BW	Channel #	Freq (MHz)	% RB Allocation	RB Position	QPSK			16 QAM		
						Factory Upper Tolerance (dBm)	M P R	Measured Output Power (dBm)	Factory Upper Tolerance (dBm)	M P R	Measured Output Power (dBm)
LTE41	20 MHz	39750	2506	1RB Low	1 Pos 0	16.00	0	15.15	16.00	1	14.27
				1RB Mid	1 Pos 50	16.00	0	14.72	16.00	1	13.90
				1RB High	1 Pos 99	16.00	0	14.03	16.00	1	13.22
				50% RB Low	50 Pos 0	16.00	1	13.85	16.00	2	12.85
				50% RB Mid	50 Pos 24	16.00	1	13.70	16.00	2	12.70
				50% RB High	50 Pos 50	16.00	1	13.43	16.00	2	12.44
				100% RB	100 Pos 0	16.00	1	13.65	16.00	2	12.62
		40185	2549.5	1RB Low	1 Pos 0	16.00	0	15.53	16.00	1	14.26
				1RB Mid	1 Pos 50	16.00	0	15.62	16.00	1	14.26
				1RB High	1 Pos 99	16.00	0	15.64	16.00	1	14.30
				50% RB Low	50 Pos 0	16.00	1	14.69	16.00	2	13.68
				50% RB Mid	50 Pos 24	16.00	1	14.59	16.00	2	13.65
				50% RB High	50 Pos 50	16.00	1	14.55	16.00	2	13.56
				100% RB	100 Pos 0	16.00	1	14.63	16.00	2	13.62
		40620	2593	1RB Low	1 Pos 0	16.00	0	14.00	16.00	1	13.00
				1RB Mid	1 Pos 50	16.00	0	14.18	16.00	1	13.20
				1RB High	1 Pos 99	16.00	0	14.29	16.00	1	13.28
				50% RB Low	50 Pos 0	16.00	1	13.09	16.00	2	12.04
				50% RB Mid	50 Pos 24	16.00	1	13.22	16.00	2	12.12
				50% RB High	50 Pos 50	16.00	1	13.24	16.00	2	12.15
				100% RB	100 Pos 0	16.00	1	13.15	16.00	2	12.13
		41055	2636.5	1RB Low	1 Pos 0	16.00	0	14.62	16.00	1	13.81
				1RB Mid	1 Pos 50	16.00	0	14.82	16.00	1	13.97
				1RB High	1 Pos 99	16.00	0	14.66	16.00	1	13.79
				50% RB Low	50 Pos 0	16.00	1	13.74	16.00	2	12.75
				50% RB Mid	50 Pos 24	16.00	1	13.81	16.00	2	12.78
				50% RB High	50 Pos 50	16.00	1	13.76	16.00	2	12.78
				100% RB	100 Pos 0	16.00	1	13.71	16.00	2	12.71
		41490	2680	1RB Low	1 Pos 0	16.00	0	14.19	16.00	1	14.96
				1RB Mid	1 Pos 50	16.00	0	14.30	16.00	1	15.00
				1RB High	1 Pos 99	16.00	0	14.20	16.00	1	14.92
				50% RB Low	50 Pos 0	16.00	1	13.24	16.00	2	12.22
				50% RB Mid	50 Pos 24	16.00	1	13.26	16.00	2	12.28
				50% RB High	50 Pos 50	16.00	1	13.29	16.00	2	12.33
				100% RB	100 Pos 0	16.00	1	13.25	16.00	2	12.25

Band	BW	Channel #	Freq (MHz)	% RB Allocation	RB Position	QPSK			16 QAM			
						Factory Upper Tolerance (dBm)	M P R	Measured Output Power (dBm)	Factory Upper Tolerance (dBm)	M P R	Measured Output Power (dBm)	
LTE41	15 MHz	39750	2506	1RB Low	1 Pos 0	16.00	0	15.01	16.00	1	14.31	
				1RB Mid	1 Pos 38	16.00	0	14.13	16.00	1	13.47	
				1RB High	1 Pos 74	16.00	0	14.68	16.00	1	14.02	
				50% RB Low	38 Pos 0	16.00	1	13.83	16.00	2	12.82	
				50% RB Mid	38 Pos 19	16.00	1	13.68	16.00	2	12.64	
				50% RB High	38 Pos 39	16.00	1	13.46	16.00	2	12.42	
		40185	2549.5	2593	1RB Low	1 Pos 0	16.00	0	15.68	16.00	1	14.72
					1RB Mid	1 Pos 38	16.00	0	15.59	16.00	1	14.64
					1RB High	1 Pos 74	16.00	0	15.62	16.00	1	14.63
					50% RB Low	38 Pos 0	16.00	1	14.59	16.00	2	13.59
					50% RB Mid	38 Pos 19	16.00	1	14.56	16.00	2	13.57
					50% RB High	38 Pos 39	16.00	1	14.56	16.00	2	13.57
		40620	2593	2636.5	100% RB	75 Pos 0	16.00	1	14.60	16.00	2	13.57
					1RB Low	1 Pos 0	16.00	0	14.00	16.00	1	13.09
					1RB Mid	1 Pos 38	16.00	0	14.20	16.00	1	13.26
					1RB High	1 Pos 74	16.00	0	14.16	16.00	1	13.22
					50% RB Low	38 Pos 0	16.00	1	13.07	16.00	2	12.08
					50% RB Mid	38 Pos 19	16.00	1	13.17	16.00	2	12.15
		41055	2636.5	2680.0	50% RB High	38 Pos 39	16.00	1	13.20	16.00	2	12.19
					100% RB	75 Pos 0	16.00	1	13.18	16.00	2	12.14
					1RB Low	1 Pos 0	16.00	0	14.69	16.00	1	14.02
					1RB Mid	1 Pos 38	16.00	0	14.73	16.00	1	14.05
					1RB High	1 Pos 74	16.00	0	14.77	16.00	1	14.13
					50% RB Low	38 Pos 0	16.00	1	13.70	16.00	2	12.76
		41490	2680.0	2680.0	50% RB Mid	38 Pos 19	16.00	1	13.74	16.00	2	12.72
					50% RB High	38 Pos 39	16.00	1	13.76	16.00	2	12.69
					100% RB	75 Pos 0	16.00	1	13.76	16.00	2	12.71
					1RB Low	1 Pos 0	16.00	0	14.31	16.00	1	13.35
					1RB Mid	1 Pos 38	16.00	0	14.26	16.00	1	13.29
					1RB High	1 Pos 74	16.00	0	14.27	16.00	1	13.30
		41490	2680.0	2680.0	50% RB Low	38 Pos 0	16.00	1	13.26	16.00	2	12.23
					50% RB Mid	38 Pos 19	16.00	1	13.28	16.00	2	12.23
					50% RB High	38 Pos 39	16.00	1	13.29	16.00	2	12.22
					100% RB	75 Pos 0	16.00	1	13.32	16.00	2	12.29

Band	BW	Channel #	Freq (MHz)	% RB Allocation	RB Position	QPSK			16 QAM			
						Factory Upper Tolerance (dBm)	M P R	Measured Output Power (dBm)	Factory Upper Tolerance (dBm)	M P R	Measured Output Power (dBm)	
LTE41	10 MHz	39750	2506	1RB Low	1 Pos 0	16.00	0	14.85	16.00	1	14.21	
				1RB Mid	1 Pos 24	16.00	0	14.71	16.00	1	14.01	
				1RB High	1 Pos 49	16.00	0	14.34	16.00	1	13.67	
				50% RB Low	25 Pos 0	16.00	1	13.72	16.00	2	12.80	
				50% RB Mid	25 Pos 12	16.00	1	13.67	16.00	2	12.74	
				50% RB High	25 Pos 24	16.00	1	13.52	16.00	2	12.60	
		40185	2549.5	2593	100% RB	50 Pos 0	16.00	1	13.71	16.00	2	12.69
					1RB Low	1 Pos 0	16.00	0	15.59	16.00	1	14.56
					1RB Mid	1 Pos 24	16.00	0	15.56	16.00	1	14.48
					1RB High	1 Pos 49	16.00	0	15.57	16.00	1	14.56
					50% RB Low	25 Pos 0	16.00	1	14.63	16.00	2	13.57
					50% RB Mid	25 Pos 12	16.00	1	14.55	16.00	2	13.57
		40620	2593	2636.5	50% RB High	25 Pos 24	16.00	1	14.56	16.00	2	13.54
					100% RB	50 Pos 0	16.00	1	14.60	16.00	2	13.55
					1RB Low	1 Pos 0	16.00	0	14.08	16.00	1	13.13
					1RB Mid	1 Pos 24	16.00	0	14.21	16.00	1	13.24
					1RB High	1 Pos 49	16.00	0	14.23	16.00	1	13.23
					50% RB Low	25 Pos 0	16.00	1	13.11	16.00	2	12.16
		41055	2636.5	2680	50% RB Mid	25 Pos 12	16.00	1	13.12	16.00	2	12.17
					100% RB	50 Pos 0	16.00	1	13.14	16.00	2	12.16
					1RB Low	1 Pos 0	16.00	1	13.14	16.00	2	12.13
					1RB Mid	1 Pos 24	16.00	0	14.70	16.00	1	14.01
					1RB High	1 Pos 49	16.00	0	14.80	16.00	1	14.09
					50% RB Low	25 Pos 0	16.00	0	14.76	16.00	1	14.09
		41490	2680	2680	50% RB Mid	25 Pos 12	16.00	1	13.71	16.00	2	12.82
					100% RB	50 Pos 0	16.00	1	13.72	16.00	2	12.82
					1RB Low	1 Pos 0	16.00	1	13.72	16.00	2	12.79
					1RB Mid	1 Pos 24	16.00	1	13.76	16.00	2	12.72
					1RB High	1 Pos 49	16.00	0	14.28	16.00	1	13.15
					50% RB Low	25 Pos 0	16.00	0	14.27	16.00	1	13.18
41490	2680	2680	50% RB Mid	25 Pos 12	16.00	0	14.33	16.00	1	13.24		
			100% RB	50 Pos 0	16.00	1	13.22	16.00	2	12.23		
			1RB Low	1 Pos 0	16.00	1	13.25	16.00	2	12.22		
			1RB Mid	1 Pos 24	16.00	1	13.30	16.00	2	12.25		
41490	2680	2680	1RB High	1 Pos 49	16.00	1	13.31	16.00	2	12.28		

Band	BW	Channel #	Freq (MHz)	% RB Allocation	RB Position	QPSK			16 QAM		
						Factory Upper Tolerance (dBm)	M P R	Measured Output Power (dBm)	Factory Upper Tolerance (dBm)	M P R	Measured Output Power (dBm)
LTE41	5.0 MHz	39750	2506	1RB Low	1 Pos 0	16.00	0	14.86	16.00	1	14.02
				1RB Mid	1 Pos 12	16.00	0	14.74	16.00	1	13.87
				1RB High	1 Pos 24	16.00	0	14.60	16.00	1	13.75
				50% RB Low	12 Pos 0	16.00	1	13.68	16.00	2	12.63
				50% RB Mid	12 Pos 6	16.00	1	13.65	16.00	2	12.58
				50% RB High	12 Pos 11	16.00	1	13.62	16.00	2	12.54
		40185	2549.5	100% RB	25 Pos 0	16.00	1	13.67	16.00	2	12.65
				1RB Low	1 Pos 0	16.00	0	15.62	16.00	1	14.81
				1RB Mid	1 Pos 12	16.00	0	15.62	16.00	1	14.76
				1RB High	1 Pos 24	16.00	0	15.60	16.00	1	14.77
				50% RB Low	12 Pos 0	16.00	1	14.58	16.00	2	13.58
				50% RB Mid	12 Pos 6	16.00	1	14.54	16.00	2	13.46
		40620	2593	50% RB High	12 Pos 11	16.00	1	14.51	16.00	2	13.48
				100% RB	25 Pos 0	16.00	1	14.59	16.00	2	13.54
				1RB Low	1 Pos 0	16.00	0	14.12	16.00	1	13.39
				1RB Mid	1 Pos 12	16.00	0	14.12	16.00	1	13.43
				1RB High	1 Pos 24	16.00	0	14.15	16.00	1	13.39
				50% RB Low	12 Pos 0	16.00	1	13.18	16.00	2	12.11
		41055	2636.5	50% RB Mid	12 Pos 6	16.00	1	13.18	16.00	2	12.13
				50% RB High	12 Pos 11	16.00	1	13.15	16.00	2	12.13
				100% RB	25 Pos 0	16.00	1	13.12	16.00	2	12.15
				1RB Low	1 Pos 0	16.00	0	14.79	16.00	1	13.93
				1RB Mid	1 Pos 12	16.00	0	14.83	16.00	1	13.98
				1RB High	1 Pos 24	16.00	0	14.84	16.00	1	13.96
		41490	2680	50% RB Low	12 Pos 0	16.00	1	13.74	16.00	2	12.74
				50% RB Mid	12 Pos 6	16.00	1	13.80	16.00	2	12.71
				50% RB High	12 Pos 11	16.00	1	13.73	16.00	2	12.68
				100% RB	25 Pos 0	16.00	1	13.71	16.00	2	12.69
				1RB Low	1 Pos 0	16.00	0	14.22	16.00	1	13.57
				1RB Mid	1 Pos 12	16.00	0	14.21	16.00	1	13.63
				1RB High	1 Pos 24	16.00	0	14.30	16.00	1	13.67
				50% RB Low	12 Pos 0	16.00	1	13.24	16.00	2	12.19
				50% RB Mid	12 Pos 6	16.00	1	13.24	16.00	2	12.18
				50% RB High	12 Pos 11	16.00	1	13.24	16.00	2	12.17
				100% RB	25 Pos 0	16.00	1	13.28	16.00	2	12.26

B.2.2.16 LTE Band 41 TDD Antenna Aux 8

Band	BW	Channel #	Freq (MHz)	% RB Allocation	RB Position	QPSK			16 QAM		
						Factory Upper Tolerance (dBm)	M P R	Measured Output Power (dBm)	Factory Upper Tolerance (dBm)	M P R	Measured Output Power (dBm)
LTE41	20 MHz	39750	2506	1RB Low	1 Pos 0	14.00	0	13.12	14.00	1	12.35
				1RB Mid	1 Pos 50	14.00	0	13.11	14.00	1	12.29
				1RB High	1 Pos 99	14.00	0	12.85	14.00	1	12.06
				50% RB Low	50 Pos 0	14.00	1	12.15	14.00	2	11.15
				50% RB Mid	50 Pos 24	14.00	1	12.10	14.00	2	11.11
				50% RB High	50 Pos 50	14.00	1	12.02	14.00	2	11.00
				100% RB	100 Pos 0	14.00	1	12.08	14.00	2	11.06
		40185	2549.5	1RB Low	1 Pos 0	14.00	0	12.91	14.00	1	11.56
				1RB Mid	1 Pos 50	14.00	0	12.99	14.00	1	11.66
				1RB High	1 Pos 99	14.00	0	12.93	14.00	1	11.61
				50% RB Low	50 Pos 0	14.00	1	12.03	14.00	2	11.04
				50% RB Mid	50 Pos 24	14.00	1	11.98	14.00	2	10.99
				50% RB High	50 Pos 50	14.00	1	11.89	14.00	2	10.97
				100% RB	100 Pos 0	14.00	1	12.02	14.00	2	10.97
		40620	2593	1RB Low	1 Pos 0	14.00	0	13.21	14.00	1	12.21
				1RB Mid	1 Pos 50	14.00	0	13.31	14.00	1	12.31
				1RB High	1 Pos 99	14.00	0	13.18	14.00	1	12.15
				50% RB Low	50 Pos 0	14.00	1	12.30	14.00	2	11.25
				50% RB Mid	50 Pos 24	14.00	1	12.29	14.00	2	11.24
				50% RB High	50 Pos 50	14.00	1	12.25	14.00	2	11.19
				100% RB	100 Pos 0	14.00	1	12.27	14.00	2	11.22
		41055	2636.5	1RB Low	1 Pos 0	14.00	0	13.13	14.00	1	12.33
				1RB Mid	1 Pos 50	14.00	0	13.11	14.00	1	12.31
				1RB High	1 Pos 99	14.00	0	12.86	14.00	1	11.98
				50% RB Low	50 Pos 0	14.00	1	12.14	14.00	2	11.13
				50% RB Mid	50 Pos 24	14.00	1	12.10	14.00	2	11.07
				50% RB High	50 Pos 50	14.00	1	12.02	14.00	2	11.01
				100% RB	100 Pos 0	14.00	1	12.08	14.00	2	11.03
		41490	2680	1RB Low	1 Pos 0	14.00	0	12.83	14.00	1	11.52
				1RB Mid	1 Pos 50	14.00	0	13.00	14.00	1	11.65
				1RB High	1 Pos 99	14.00	0	12.95	14.00	1	11.66
				50% RB Low	50 Pos 0	14.00	1	12.01	14.00	2	10.97
				50% RB Mid	50 Pos 24	14.00	1	12.03	14.00	2	11.01
				50% RB High	50 Pos 50	14.00	1	12.00	14.00	2	11.02
				100% RB	100 Pos 0	14.00	1	11.99	14.00	2	10.98

Band	BW	Channel #	Freq (MHz)	% RB Allocation	RB Position	QPSK			16 QAM			
						Factory Upper Tolerance (dBm)	M P R	Measured Output Power (dBm)	Factory Upper Tolerance (dBm)	M P R	Measured Output Power (dBm)	
LTE41	15 MHz	39750	2506	1RB Low	1 Pos 0	14.00	0	13.10	14.00	1	12.46	
				1RB Mid	1 Pos 38	14.00	0	13.08	14.00	1	12.36	
				1RB High	1 Pos 74	14.00	0	12.88	14.00	1	12.19	
				50% RB Low	38 Pos 0	14.00	1	12.13	14.00	2	11.12	
				50% RB Mid	38 Pos 19	14.00	1	12.08	14.00	2	11.09	
				50% RB High	38 Pos 39	14.00	1	12.03	14.00	2	11.00	
		40185	2549.5	2593	100% RB	75 Pos 0	14.00	1	12.08	14.00	2	11.04
					1RB Low	1 Pos 0	14.00	0	12.97	14.00	1	12.03
					1RB Mid	1 Pos 38	14.00	0	12.94	14.00	1	12.00
					1RB High	1 Pos 74	14.00	0	12.91	14.00	1	11.95
					50% RB Low	38 Pos 0	14.00	1	11.93	14.00	2	10.97
					50% RB Mid	38 Pos 19	14.00	1	11.96	14.00	2	10.89
		40620	2593	2636.5	50% RB High	38 Pos 39	14.00	1	11.93	14.00	2	10.90
					100% RB	75 Pos 0	14.00	1	11.98	14.00	2	10.95
					1RB Low	1 Pos 0	14.00	0	13.22	14.00	1	12.29
					1RB Mid	1 Pos 38	14.00	0	13.24	14.00	1	12.29
					1RB High	1 Pos 74	14.00	0	13.17	14.00	1	12.22
					50% RB Low	38 Pos 0	14.00	1	12.26	14.00	2	11.22
		41055	2636.5	2680.0	50% RB Mid	38 Pos 19	14.00	1	12.20	14.00	2	11.27
					50% RB High	38 Pos 39	14.00	1	12.21	14.00	2	11.18
					100% RB	75 Pos 0	14.00	1	12.24	14.00	2	11.26
					1RB Low	1 Pos 0	14.00	0	13.10	14.00	1	12.46
					1RB Mid	1 Pos 38	14.00	0	13.07	14.00	1	12.40
					1RB High	1 Pos 74	14.00	0	12.85	14.00	1	12.22
		41490	2680.0	2680.0	50% RB Low	38 Pos 0	14.00	1	12.12	14.00	2	11.11
					50% RB Mid	38 Pos 19	14.00	1	12.02	14.00	2	10.99
					50% RB High	38 Pos 39	14.00	1	11.92	14.00	2	10.99
					100% RB	75 Pos 0	14.00	1	12.03	14.00	2	11.04
					1RB Low	1 Pos 0	14.00	0	12.95	14.00	1	11.99
					1RB Mid	1 Pos 38	14.00	0	12.94	14.00	1	12.04
		41490	2680.0	2680.0	1RB High	1 Pos 74	14.00	0	12.96	14.00	1	12.02
					50% RB Low	38 Pos 0	14.00	1	11.90	14.00	2	10.87
					50% RB Mid	38 Pos 19	14.00	1	11.96	14.00	2	10.93
					50% RB High	38 Pos 39	14.00	1	11.97	14.00	2	10.90
					100% RB	75 Pos 0	14.00	1	11.99	14.00	2	10.97

Band	BW	Channel #	Freq (MHz)	% RB Allocation	RB Position	QPSK			16 QAM		
						Factory Upper Tolerance (dBm)	M P R	Measured Output Power (dBm)	Factory Upper Tolerance (dBm)	M P R	Measured Output Power (dBm)
LTE41	5.0 MHz	39750	2506	1RB Low	1 Pos 0	14.00	0	13.09	14.00	1	12.30
				1RB Mid	1 Pos 12	14.00	0	13.08	14.00	1	12.23
				1RB High	1 Pos 24	14.00	0	13.01	14.00	1	12.17
				50% RB Low	12 Pos 0	14.00	1	12.07	14.00	2	10.97
				50% RB Mid	12 Pos 6	14.00	1	12.04	14.00	2	10.99
				50% RB High	12 Pos 11	14.00	1	12.02	14.00	2	10.93
		40185	2549.5	100% RB	25 Pos 0	14.00	1	12.00	14.00	2	11.01
				1RB Low	1 Pos 0	14.00	0	12.94	14.00	1	12.29
				1RB Mid	1 Pos 12	14.00	0	12.99	14.00	1	12.29
				1RB High	1 Pos 24	14.00	0	12.92	14.00	1	12.25
				50% RB Low	12 Pos 0	14.00	1	11.98	14.00	2	10.90
				50% RB Mid	12 Pos 6	14.00	1	11.90	14.00	2	10.87
		40620	2593	50% RB High	12 Pos 11	14.00	1	11.84	14.00	2	10.81
				100% RB	25 Pos 0	14.00	1	11.92	14.00	2	10.91
				1RB Low	1 Pos 0	14.00	0	13.24	14.00	1	12.51
				1RB Mid	1 Pos 12	14.00	0	13.18	14.00	1	12.50
				1RB High	1 Pos 24	14.00	0	13.17	14.00	1	12.44
				50% RB Low	12 Pos 0	14.00	1	12.25	14.00	2	11.25
		41055	2636.5	50% RB Mid	12 Pos 6	14.00	1	12.17	14.00	2	11.20
				50% RB High	12 Pos 11	14.00	1	12.19	14.00	2	11.21
				100% RB	25 Pos 0	14.00	1	12.23	14.00	2	11.22
				1RB Low	1 Pos 0	14.00	0	13.13	14.00	1	12.33
				1RB Mid	1 Pos 12	14.00	0	13.10	14.00	1	12.29
				1RB High	1 Pos 24	14.00	0	13.03	14.00	1	12.21
		41490	2680	50% RB Low	12 Pos 0	14.00	1	12.09	14.00	2	10.97
				50% RB Mid	12 Pos 6	14.00	1	12.06	14.00	2	11.01
				50% RB High	12 Pos 11	14.00	1	12.02	14.00	2	10.91
				100% RB	25 Pos 0	14.00	1	11.99	14.00	2	11.01
				1RB Low	1 Pos 0	14.00	0	12.94	14.00	1	12.31
				1RB Mid	1 Pos 12	14.00	0	12.94	14.00	1	12.32
				1RB High	1 Pos 24	14.00	0	12.98	14.00	1	12.33
				50% RB Low	12 Pos 0	14.00	1	11.96	14.00	2	10.85
				50% RB Mid	12 Pos 6	14.00	1	11.92	14.00	2	10.84
				50% RB High	12 Pos 11	14.00	1	11.94	14.00	2	10.85
				100% RB	25 Pos 0	14.00	1	11.92	14.00	2	10.96

B.2.2.17 LTE Band 48 FDD Antenna Aux 8

Band	BW	Channel #	Freq (MHz)	% RB Allocation	RB Position	QPSK			16 QAM		
						Factory Upper Tolerance (dBm)	M P R	Measured Output Power (dBm)	Factory Upper Tolerance (dBm)	M P R	Measured Output Power (dBm)
LTE 48	20 MHz	55340	3560	1RB Low	1 Pos 0	15.00	0	14.75	15.00	1	13.68
				1RB Mid	1 Pos 50	15.00	0	14.92	15.00	1	13.85
				1RB High	1 Pos 99	15.00	0	14.82	15.00	1	13.75
				50% RB Low	50 Pos 0	15.00	1	13.71	15.00	2	12.77
				50% RB Mid	50 Pos 24	15.00	1	13.78	15.00	2	12.84
				50% RB High	50 Pos 50	15.00	1	13.76	15.00	2	12.80
		100% RB	100 Pos 0	15.00	1	13.76	15.00	2	12.80		
		55990	3625	1RB Low	1 Pos 0	15.00	0	14.77	15.00	1	13.78
				1RB Mid	1 Pos 50	15.00	0	14.91	15.00	1	13.90
				1RB High	1 Pos 99	15.00	0	14.76	15.00	1	13.73
				50% RB Low	50 Pos 0	15.00	1	13.89	15.00	2	12.88
				50% RB Mid	50 Pos 24	15.00	1	13.96	15.00	2	12.92
				50% RB High	50 Pos 50	15.00	1	13.90	15.00	2	12.91
		100% RB	100 Pos 0	15.00	1	12.86	15.00	2	12.85		
		56640	3690	1RB Low	1 Pos 0	15.00	0	14.39	15.00	1	13.57
				1RB Mid	1 Pos 50	15.00	0	14.44	15.00	1	13.60
				1RB High	1 Pos 99	15.00	0	14.19	15.00	1	13.37
				50% RB Low	50 Pos 0	15.00	1	13.45	15.00	2	12.46
	50% RB Mid			50 Pos 24	15.00	1	13.42	15.00	2	12.43	
	50% RB High			50 Pos 50	15.00	1	13.36	15.00	2	12.32	
	100% RB	100 Pos 0	15.00	1	13.40	15.00	2	12.30			
	15 MHz	55315	3557.5	1RB Low	1 Pos 0	15.00	0	14.50	15.00	1	13.88
				1RB Mid	1 Pos 38	15.00	0	14.67	15.00	1	13.98
				1RB High	1 Pos 74	15.00	0	14.61	15.00	1	13.95
				50% RB Low	38 Pos 0	15.00	1	13.68	15.00	2	12.75
				50% RB Mid	38 Pos 19	15.00	1	13.73	15.00	2	12.75
				50% RB High	38 Pos 39	15.00	1	13.78	15.00	2	12.74
		100% RB	75 Pos 0	15.00	1	13.73	15.00	2	12.68		
		55990	3625	1RB Low	1 Pos 0	15.00	0	14.77	15.00	1	13.02
				1RB Mid	1 Pos 38	15.00	0	14.88	15.00	1	13.18
				1RB High	1 Pos 74	15.00	0	14.80	15.00	1	13.12
				50% RB Low	38 Pos 0	15.00	1	13.80	15.00	2	12.92
				50% RB Mid	38 Pos 19	15.00	1	13.87	15.00	2	12.92
				50% RB High	38 Pos 39	15.00	1	13.86	15.00	2	12.93
		100% RB	75 Pos 0	15.00	1	13.83	15.00	2	12.84		
		56665	3692.5	1RB Low	1 Pos 0	15.00	0	14.35	15.00	1	13.65
				1RB Mid	1 Pos 38	15.00	0	14.43	15.00	1	13.68
				1RB High	1 Pos 74	15.00	0	14.27	15.00	1	13.54
				50% RB Low	38 Pos 0	15.00	1	13.41	15.00	2	12.35
	50% RB Mid			38 Pos 19	15.00	1	13.35	15.00	2	12.36	
	50% RB High			38 Pos 39	15.00	1	13.34	15.00	2	12.27	
	100% RB	75 Pos 0	15.00	1	13.37	15.00	2	12.37			
	10 MHz	55290	3555	1RB Low	1 Pos 0	15.00	0	14.76	15.00	1	13.95
				1RB Mid	1 Pos 24	15.00	0	14.77	15.00	1	13.98
				1RB High	1 Pos 49	15.00	0	14.78	15.00	1	14.00
				50% RB Low	25 Pos 0	15.00	1	13.73	15.00	2	12.75
				50% RB Mid	25 Pos 12	15.00	1	13.75	15.00	2	12.76
				50% RB High	25 Pos 25	15.00	1	13.79	15.00	2	12.74
100% RB		50 Pos0	15.00	1	13.76	15.00	2	12.79			
55990		3625	1RB Low	1 Pos 0	15.00	0	14.82	15.00	1	13.73	
			1RB Mid	1 Pos 24	15.00	0	14.87	15.00	1	13.78	
			1RB High	1 Pos 49	15.00	0	14.86	15.00	1	13.79	
			50% RB Low	25 Pos 0	15.00	1	13.91	15.00	2	12.89	
			50% RB Mid	25 Pos 12	15.00	1	13.88	15.00	2	12.88	
			50% RB High	25 Pos 25	15.00	1	13.93	15.00	2	12.87	
100% RB		50 Pos0	15.00	1	13.92	15.00	2	12.90			
56690		3695	1RB Low	1 Pos 0	15.00	0	14.34	15.00	1	13.90	
			1RB Mid	1 Pos 24	15.00	0	14.36	15.00	1	13.94	
			1RB High	1 Pos 49	15.00	0	14.28	15.00	1	13.83	
			50% RB Low	25 Pos 0	15.00	1	13.38	15.00	2	12.43	
	50% RB Mid		25 Pos 12	15.00	1	13.35	15.00	2	12.43		
	50% RB High		25 Pos 25	15.00	1	13.35	15.00	2	12.41		
100% RB	50 Pos0	15.00	1	13.33	15.00	2	12.35				

Band	BW	Channel #	Freq (MHz)	% RB Allocation	RB Position	QPSK			16 QAM		
						Factory Upper Tolerance (dBm)	M P R	Measured Output Power (dBm)	Factory Upper Tolerance (dBm)	M P R	Measured Output Power (dBm)
LTE 48	5 MHz	55265	3552.5	1RB Low	1 Pos 0	15.00	0	14.68	15.00	1	13.95
				1RB Mid	1 Pos 12	15.00	0	14.69	15.00	1	13.94
				1RB High	1 Pos 24	15.00	0	14.70	15.00	1	13.96
				50% RB Low	12 Pos 0	15.00	1	13.61	15.00	2	12.56
				50% RB Mid	12 Pos 6	15.00	1	13.64	15.00	2	12.56
				50% RB High	12 Pos 11	15.00	1	13.64	15.00	2	12.57
				100% RB	25 Pos 0	15.00	1	13.65	15.00	2	12.65
		55990	3625	1RB Low	1 Pos 0	15.00	0	14.87	15.00	1	13.51
				1RB Mid	1 Pos 12	15.00	0	14.83	15.00	1	13.52
				1RB High	1 Pos 24	15.00	0	14.81	15.00	1	13.49
				50% RB Low	12 Pos 0	15.00	1	13.82	15.00	2	12.80
				50% RB Mid	12 Pos 6	15.00	1	13.79	15.00	2	12.83
				50% RB High	12 Pos 11	15.00	1	13.81	15.00	2	12.83
				100% RB	25 Pos 0	15.00	1	13.83	15.00	2	12.77
		56715	3697.5	1RB Low	1 Pos 0	15.00	0	14.39	15.00	1	13.94
				1RB Mid	1 Pos 12	15.00	0	14.40	15.00	1	13.88
				1RB High	1 Pos 24	15.00	0	14.31	15.00	1	13.84
				50% RB Low	12 Pos 0	15.00	1	13.26	15.00	2	12.27
				50% RB Mid	12 Pos 6	15.00	1	13.24	15.00	2	12.24
				50% RB High	12 Pos 11	15.00	1	13.22	15.00	2	12.21
				100% RB	25 Pos 0	15.00	1	13.30	15.00	2	12.22

B.2.2.18 LTE Band 66 FDD Antenna Main 5

Band	BW	Channel #	Freq (MHz)	% RB Allocation	RB Position	QPSK			16 QAM		
						Factory Upper Tolerance (dBm)	M P R	Measured Output Power (dBm)	Factory Upper Tolerance (dBm)	M P R	Measured Output Power (dBm)
LTE66	20 MHz	132072	1720	1RB Low	1 Pos 0	19.00	0	17.91	19.00	1	17.06
				1RB Mid	1 Pos 50	19.00	0	17.96	19.00	1	17.16
				1RB High	1 Pos 99	19.00	0	17.85	19.00	1	17.04
				50% RB Low	50 Pos 0	19.00	1	16.90	19.00	2	15.88
				50% RB Mid	50 Pos 24	19.00	1	16.93	19.00	2	15.94
				50% RB High	50 Pos 50	19.00	1	16.84	19.00	2	15.79
		100% RB	100 Pos 0	19.00	1	16.86	19.00	2	15.81		
		132322	1745	1RB Low	1 Pos 0	19.00	0	17.86	19.00	1	16.65
				1RB Mid	1 Pos 50	19.00	0	17.96	19.00	1	16.78
				1RB High	1 Pos 99	19.00	0	17.88	19.00	1	16.65
				50% RB Low	50 Pos 0	19.00	1	16.97	19.00	2	15.98
				50% RB Mid	50 Pos 24	19.00	1	16.96	19.00	2	15.95
				50% RB High	50 Pos 50	19.00	1	16.82	19.00	2	15.81
		100% RB	100 Pos 0	19.00	1	16.91	19.00	2	15.86		
		132572	1770	1RB Low	1 Pos 0	19.00	0	17.94	19.00	1	16.69
				1RB Mid	1 Pos 50	19.00	0	18.01	19.00	1	16.78
				1RB High	1 Pos 99	19.00	0	17.91	19.00	1	16.68
				50% RB Low	50 Pos 0	19.00	1	16.87	19.00	2	15.84
	50% RB Mid			50 Pos 24	19.00	1	16.95	19.00	2	15.87	
	50% RB High			50 Pos 50	19.00	1	16.95	19.00	2	15.88	
	100% RB	100 Pos 0	19.00	1	16.92	19.00	2	15.91			
	15 MHz	132047	1717.5	1RB Low	1 Pos 0	19.00	0	17.92	19.00	1	17.20
				1RB Mid	1 Pos 38	19.00	0	17.80	19.00	1	17.12
				1RB High	1 Pos 74	19.00	0	17.93	19.00	1	17.25
				50% RB Low	38 Pos 0	19.00	1	16.90	19.00	2	15.85
				50% RB Mid	38 Pos 19	19.00	1	16.92	19.00	2	15.91
				50% RB High	38 Pos 39	19.00	1	16.86	19.00	2	15.85
		100% RB	75 Pos 0	19.00	1	16.91	19.00	2	15.87		
		132422	1755	1RB Low	1 Pos 0	19.00	0	17.94	19.00	1	16.95
				1RB Mid	1 Pos 38	19.00	0	17.87	19.00	1	16.87
				1RB High	1 Pos 74	19.00	0	17.96	19.00	1	16.99
				50% RB Low	38 Pos 0	19.00	1	16.92	19.00	2	15.89
				50% RB Mid	38 Pos 19	19.00	1	16.90	19.00	2	15.88
				50% RB High	38 Pos 39	19.00	1	16.85	19.00	2	15.81
		100% RB	75 Pos 0	19.00	1	16.93	19.00	2	15.87		
		132597	1772.5	1RB Low	1 Pos 0	19.00	0	17.89	19.00	1	17.06
				1RB Mid	1 Pos 38	19.00	0	17.86	19.00	1	17.01
				1RB High	1 Pos 74	19.00	0	17.93	19.00	1	17.10
				50% RB Low	38 Pos 0	19.00	1	16.88	19.00	2	15.88
	50% RB Mid			38 Pos 19	19.00	1	16.92	19.00	2	15.92	
	50% RB High			38 Pos 39	19.00	1	16.90	19.00	2	15.95	
	100% RB	75 Pos 0	19.00	1	16.93	19.00	2	15.86			
	10 MHz	132022	1715	1RB Low	1 Pos 0	19.00	0	17.98	19.00	1	17.27
				1RB Mid	1 Pos 24	19.00	0	17.93	19.00	1	17.21
				1RB High	1 Pos 49	19.00	0	17.92	19.00	1	17.19
				50% RB Low	25 Pos 0	19.00	1	16.87	19.00	2	15.92
				50% RB Mid	25 Pos 12	19.00	1	16.89	19.00	2	15.98
				50% RB High	25 Pos 24	19.00	1	16.91	19.00	2	15.97
100% RB		50 Pos 0	19.00	1	16.92	19.00	2	15.88			
132422		1755	1RB Low	1 Pos 0	19.00	0	17.95	19.00	1	16.79	
			1RB Mid	1 Pos 24	19.00	0	18.01	19.00	1	16.80	
			1RB High	1 Pos 49	19.00	0	18.00	19.00	1	16.76	
			50% RB Low	25 Pos 0	19.00	1	16.95	19.00	2	15.94	
			50% RB Mid	25 Pos 12	19.00	1	16.84	19.00	2	15.89	
			50% RB High	25 Pos 24	19.00	1	16.82	19.00	2	15.84	
100% RB		50 Pos 0	19.00	1	16.91	19.00	2	15.90			
132622		1775	1RB Low	1 Pos 0	19.00	0	17.94	19.00	1	17.09	
			1RB Mid	1 Pos 24	19.00	0	17.94	19.00	1	17.07	
			1RB High	1 Pos 49	19.00	0	17.94	19.00	1	17.08	
			50% RB Low	25 Pos 0	19.00	1	16.87	19.00	2	15.90	
	50% RB Mid		25 Pos 12	19.00	1	16.86	19.00	2	15.88		
	50% RB High		25 Pos 24	19.00	1	16.90	19.00	2	15.89		
100% RB	50 Pos 0	19.00	1	16.92	19.00	2	15.86				

Band	BW	Channel #	Freq (MHz)	% RB Allocation	RB Position	QPSK			16 QAM			
						Factory Upper Tolerance (dBm)	M P R	Measured Output Power (dBm)	Factory Upper Tolerance (dBm)	M P R	Measured Output Power (dBm)	
LTE66	5.0 MHz	131997	1712.5	1RB Low	1 Pos 0	19.00	0	18.07	19.00	1	17.28	
				1RB Mid	1 Pos 12	19.00	0	18.04	19.00	1	17.22	
				1RB High	1 Pos 24	19.00	0	18.04	19.00	1	17.22	
				50% RB Low	12 Pos 0	19.00	1	16.95	19.00	2	15.91	
				50% RB Mid	12 Pos 6	19.00	1	16.90	19.00	2	15.89	
				50% RB High	12 Pos 11	19.00	1	16.91	19.00	2	15.85	
		100% RB	25 Pos 0	19.00	1	16.96	19.00	2	15.93			
		132422	1755	1RB Low	1 Pos 0	19.00	0	17.92	19.00	1	17.17	
				1RB Mid	1 Pos 12	19.00	0	17.96	19.00	1	17.16	
				1RB High	1 Pos 24	19.00	0	17.91	19.00	1	17.16	
				50% RB Low	12 Pos 0	19.00	1	16.95	19.00	2	15.92	
				50% RB Mid	12 Pos 6	19.00	1	16.87	19.00	2	15.88	
				50% RB High	12 Pos 11	19.00	1	16.80	19.00	2	15.80	
		100% RB	25 Pos 0	19.00	1	16.90	19.00	2	15.90			
		132647	1777.5	1RB Low	1 Pos 0	19.00	0	17.96	19.00	1	17.14	
				1RB Mid	1 Pos 12	19.00	0	17.98	19.00	1	17.11	
				1RB High	1 Pos 24	19.00	0	18.00	19.00	1	17.12	
				50% RB Low	12 Pos 0	19.00	1	16.92	19.00	2	15.81	
				50% RB Mid	12 Pos 6	19.00	1	16.93	19.00	2	15.84	
				50% RB High	12 Pos 11	19.00	1	16.88	19.00	2	15.78	
		100% RB	25 Pos 0	19.00	1	16.89	19.00	2	15.84			
		3.0 MHz	131987	1711.5	1RB Low	1 Pos 0	19.00	0	17.95	19.00	1	17.24
					1RB Mid	1 Pos 7	19.00	0	17.94	19.00	1	17.29
					1RB High	1 Pos 14	19.00	0	17.88	19.00	1	17.21
					50% RB Low	8 Pos 0	19.00	1	16.95	19.00	2	15.95
					50% RB Mid	8 Pos 4	19.00	1	16.96	19.00	2	15.98
					50% RB High	8 Pos 7	19.00	1	16.92	19.00	2	15.91
			100% RB	15 Pos 0	19.00	1	16.94	19.00	2	15.86		
			132422	1755	1RB Low	1 Pos 0	19.00	0	17.87	19.00	1	17.16
					1RB Mid	1 Pos 7	19.00	0	17.91	19.00	1	17.22
	1RB High				1 Pos 14	19.00	0	17.83	19.00	1	17.15	
	50% RB Low				8 Pos 0	19.00	1	16.88	19.00	2	15.92	
	50% RB Mid				8 Pos 4	19.00	1	16.86	19.00	2	15.89	
	50% RB High				8 Pos 7	19.00	1	16.83	19.00	2	15.84	
	100% RB		15 Pos 0	19.00	1	16.87	19.00	2	15.79			
	132657		1778.5	1RB Low	1 Pos 0	19.00	0	17.89	19.00	1	17.18	
				1RB Mid	1 Pos 7	19.00	0	17.91	19.00	1	17.22	
				1RB High	1 Pos 14	19.00	0	17.84	19.00	1	17.20	
				50% RB Low	8 Pos 0	19.00	1	16.89	19.00	2	15.93	
				50% RB Mid	8 Pos 4	19.00	1	16.91	19.00	2	15.91	
				50% RB High	8 Pos 7	19.00	1	16.90	19.00	2	15.89	
	100% RB		15 Pos 0	19.00	1	16.91	19.00	2	15.84			
	1.4 MHz		131979	1710	1RB Low	1 Pos 0	19.00	0	18.01	19.00	1	16.98
					1RB Mid	1 Pos 2	19.00	0	18.09	19.00	1	17.07
					1RB High	1 Pos 5	19.00	0	18.05	19.00	1	16.97
					50% RB Low	3 Pos 0	19.00	1	17.96	19.00	1	17.09
					50% RB Mid	3 Pos 1	19.00	1	17.97	19.00	1	17.12
					50% RB High	3 Pos 2	19.00	1	17.98	19.00	1	17.16
			100% RB	6 Pos 0	19.00	1	16.95	19.00	2	15.94		
			132422	1755	1RB Low	1 Pos 0	19.00	0	17.94	19.00	1	16.93
					1RB Mid	1 Pos 2	19.00	0	18.04	19.00	1	17.00
		1RB High			1 Pos 5	19.00	0	17.95	19.00	1	16.92	
		50% RB Low			3 Pos 0	19.00	1	17.93	19.00	1	17.05	
		50% RB Mid			3 Pos 1	19.00	1	17.91	19.00	1	17.03	
		50% RB High			3 Pos 2	19.00	1	17.88	19.00	1	17.03	
		100% RB	6 Pos 0	19.00	1	16.87	19.00	2	15.87			
		132665	1779.3	1RB Low	1 Pos 0	19.00	0	17.99	19.00	1	16.93	
				1RB Mid	1 Pos 2	19.00	0	18.02	19.00	1	17.01	
				1RB High	1 Pos 5	19.00	0	17.98	19.00	1	16.93	
				50% RB Low	3 Pos 0	19.00	1	17.90	19.00	1	17.06	
				50% RB Mid	3 Pos 1	19.00	1	17.92	19.00	1	17.07	
				50% RB High	3 Pos 2	19.00	1	17.94	19.00	1	17.11	
		100% RB	6 Pos 0	19.00	1	16.90	19.00	2	15.91			

B.2.2.19 LTE Band 66 FDD Antenna Aux 8

Band	BW	Channel #	Freq (MHz)	% RB Allocation	RB Position	QPSK			16 QAM		
						Factory Upper Tolerance (dBm)	M P R	Measured Output Power (dBm)	Factory Upper Tolerance (dBm)	M P R	Measured Output Power (dBm)
LTE66	20 MHz	132072	1720	1RB Low	1 Pos 0	18.50	0	17.60	18.50	1	16.89
				1RB Mid	1 Pos 50	18.50	0	17.72	18.50	1	17.03
				1RB High	1 Pos 99	18.50	0	17.63	18.50	1	16.92
				50% RB Low	50 Pos 0	18.50	1	16.65	18.50	2	15.61
				50% RB Mid	50 Pos 24	18.50	1	16.66	18.50	2	15.61
				50% RB High	50 Pos 50	18.50	1	16.64	18.50	2	15.59
		100% RB	100 Pos 0	18.50	1	16.65	18.50	2	15.62		
		132322	1745	1RB Low	1 Pos 0	18.50	0	17.59	18.50	1	17.18
				1RB Mid	1 Pos 50	18.50	0	17.69	18.50	1	17.27
				1RB High	1 Pos 99	18.50	0	17.59	18.50	1	17.16
				50% RB Low	50 Pos 0	18.50	1	16.75	18.50	2	15.76
				50% RB Mid	50 Pos 24	18.50	1	16.74	18.50	2	15.68
				50% RB High	50 Pos 50	18.50	1	16.63	18.50	2	15.61
		100% RB	100 Pos 0	18.50	1	16.71	18.50	2	15.68		
		132572	1770	1RB Low	1 Pos 0	18.50	0	17.67	18.50	1	16.84
				1RB Mid	1 Pos 50	18.50	0	17.71	18.50	1	16.85
				1RB High	1 Pos 99	18.50	0	17.59	18.50	1	16.74
				50% RB Low	50 Pos 0	18.50	1	16.55	18.50	2	15.53
	50% RB Mid			50 Pos 24	18.50	1	16.67	18.50	2	15.63	
	50% RB High			50 Pos 50	18.50	1	16.58	18.50	2	15.55	
	100% RB	100 Pos 0	18.50	1	16.56	18.50	2	15.52			
	15 MHz	132047	1717.5	1RB Low	1 Pos 0	18.50	0	17.59	18.50	1	17.19
				1RB Mid	1 Pos 38	18.50	0	17.50	18.50	1	17.13
				1RB High	1 Pos 74	18.50	0	17.61	18.50	1	17.20
				50% RB Low	38 Pos 0	18.50	1	16.65	18.50	2	15.62
				50% RB Mid	38 Pos 19	18.50	1	16.60	18.50	2	15.62
				50% RB High	38 Pos 39	18.50	1	16.60	18.50	2	15.59
		100% RB	75 Pos 0	18.50	1	16.60	18.50	2	15.63		
		132422	1755	1RB Low	1 Pos 0	18.50	0	17.62	18.50	1	17.04
				1RB Mid	1 Pos 38	18.50	0	17.58	18.50	1	16.99
				1RB High	1 Pos 74	18.50	0	17.69	18.50	1	17.09
				50% RB Low	38 Pos 0	18.50	1	16.72	18.50	2	15.70
				50% RB Mid	38 Pos 19	18.50	1	16.67	18.50	2	15.68
				50% RB High	38 Pos 39	18.50	1	16.64	18.50	2	15.60
		100% RB	75 Pos 0	18.50	1	16.71	18.50	2	15.66		
		132597	1772.5	1RB Low	1 Pos 0	18.50	0	17.62	18.50	1	16.77
				1RB Mid	1 Pos 38	18.50	0	17.56	18.50	1	16.71
				1RB High	1 Pos 74	18.50	0	17.63	18.50	1	16.78
				50% RB Low	38 Pos 0	18.50	1	16.62	18.50	2	15.56
	50% RB Mid			38 Pos 19	18.50	1	16.66	18.50	2	15.61	
	50% RB High			38 Pos 39	18.50	1	16.57	18.50	2	15.55	
	100% RB	75 Pos 0	18.50	1	16.60	18.50	2	15.58			
	10 MHz	132022	1715	1RB Low	1 Pos 0	18.50	0	17.64	18.50	1	17.20
				1RB Mid	1 Pos 24	18.50	0	17.60	18.50	1	17.19
				1RB High	1 Pos 49	18.50	0	17.60	18.50	1	17.20
				50% RB Low	25 Pos 0	18.50	1	16.65	18.50	2	15.68
				50% RB Mid	25 Pos 12	18.50	1	16.60	18.50	2	15.66
				50% RB High	25 Pos 24	18.50	1	16.59	18.50	2	15.63
100% RB		50 Pos 0	18.50	1	16.61	18.50	2	15.61			
132422		1755	1RB Low	1 Pos 0	18.50	0	17.68	18.50	1	16.67	
			1RB Mid	1 Pos 24	18.50	0	17.72	18.50	1	16.72	
			1RB High	1 Pos 49	18.50	0	17.69	18.50	1	16.64	
			50% RB Low	25 Pos 0	18.50	1	16.72	18.50	2	15.81	
			50% RB Mid	25 Pos 12	18.50	1	16.62	18.50	2	15.72	
			50% RB High	25 Pos 24	18.50	1	16.62	18.50	2	15.70	
100% RB		50 Pos 0	18.50	1	16.75	18.50	2	15.70			
132622		1775	1RB Low	1 Pos 0	18.50	0	17.66	18.50	1	16.77	
			1RB Mid	1 Pos 24	18.50	0	17.68	18.50	1	16.79	
			1RB High	1 Pos 49	18.50	0	17.65	18.50	1	16.77	
			50% RB Low	25 Pos 0	18.50	1	16.62	18.50	2	15.62	
	50% RB Mid		25 Pos 12	18.50	1	16.63	18.50	2	15.64		
	50% RB High		25 Pos 24	18.50	1	16.56	18.50	2	15.57		
100% RB	50 Pos 0	18.50	1	16.62	18.50	2	15.57				

Band	BW	Channel #	Freq (MHz)	% RB Allocation	RB Position	QPSK			16 QAM		
						Factory Upper Tolerance (dBm)	M P R	Measured Output Power (dBm)	Factory Upper Tolerance (dBm)	M P R	Measured Output Power (dBm)
LTE66	5.0 MHz	131997	1712.5	1RB Low	1 Pos 0	18.50	0	17.79	18.50	1	16.57
				1RB Mid	1 Pos 12	18.50	0	17.77	18.50	1	16.51
				1RB High	1 Pos 24	18.50	0	17.72	18.50	1	16.51
				50% RB Low	12 Pos 0	18.50	1	16.62	18.50	2	15.63
				50% RB Mid	12 Pos 6	18.50	1	16.63	18.50	2	15.57
				50% RB High	12 Pos 11	18.50	1	16.58	18.50	2	15.53
		100% RB	25 Pos 0	18.50	1	16.61	18.50	2	15.64		
		1RB Low	1 Pos 0	18.50	0	17.73	18.50	1	16.75		
		1RB Mid	1 Pos 12	18.50	0	17.70	18.50	1	16.74		
		1RB High	1 Pos 24	18.50	0	17.70	18.50	1	16.74		
		50% RB Low	12 Pos 0	18.50	1	16.71	18.50	2	15.66		
		50% RB Mid	12 Pos 6	18.50	1	16.61	18.50	2	15.58		
		50% RB High	12 Pos 11	18.50	1	16.60	18.50	2	15.53		
		100% RB	25 Pos 0	18.50	1	16.68	18.50	2	15.68		
		1RB Low	1 Pos 0	18.50	0	17.71	18.50	1	16.93		
		1RB Mid	1 Pos 12	18.50	0	17.69	18.50	1	16.96		
		1RB High	1 Pos 24	18.50	0	17.71	18.50	1	16.97		
		50% RB Low	12 Pos 0	18.50	1	16.67	18.50	2	15.65		
		50% RB Mid	12 Pos 6	18.50	1	16.61	18.50	2	15.63		
		50% RB High	12 Pos 11	18.50	1	16.56	18.50	2	15.57		
		100% RB	25 Pos 0	18.50	1	16.62	18.50	2	15.61		
		1RB Low	1 Pos 0	18.50	0	17.61	18.50	1	17.19		
		1RB Mid	1 Pos 7	18.50	0	17.60	18.50	1	17.21		
		1RB High	1 Pos 14	18.50	0	17.53	18.50	1	17.15		
		50% RB Low	8 Pos 0	18.50	1	16.58	18.50	2	15.76		
		50% RB Mid	8 Pos 4	18.50	1	16.62	18.50	2	15.78		
		50% RB High	8 Pos 7	18.50	1	16.53	18.50	2	15.71		
		100% RB	15 Pos 0	18.50	1	16.56	18.50	2	15.64		
		1RB Low	1 Pos 0	18.50	0	17.63	18.50	1	17.25		
		1RB Mid	1 Pos 7	18.50	0	17.62	18.50	1	17.27		
	1RB High	1 Pos 14	18.50	0	17.61	18.50	1	17.22			
	50% RB Low	8 Pos 0	18.50	1	16.62	18.50	2	15.82			
	50% RB Mid	8 Pos 4	18.50	1	16.58	18.50	2	15.77			
	50% RB High	8 Pos 7	18.50	1	16.61	18.50	2	15.76			
	100% RB	15 Pos 0	18.50	1	16.62	18.50	2	15.67			
	1RB Low	1 Pos 0	18.50	0	17.65	18.50	1	17.23			
	1RB Mid	1 Pos 7	18.50	0	17.61	18.50	1	17.17			
	1RB High	1 Pos 14	18.50	0	17.59	18.50	1	17.18			
	50% RB Low	8 Pos 0	18.50	1	16.59	18.50	2	15.81			
	50% RB Mid	8 Pos 4	18.50	1	16.59	18.50	2	15.80			
	50% RB High	8 Pos 7	18.50	1	16.61	18.50	2	15.76			
	100% RB	15 Pos 0	18.50	1	16.62	18.50	2	15.68			
	1RB Low	1 Pos 0	18.50	0	17.64	18.50	1	16.63			
	1RB Mid	1 Pos 2	18.50	0	17.58	18.50	1	16.60			
	1RB High	1 Pos 5	18.50	0	17.58	18.50	1	16.62			
	50% RB Low	3 Pos 0	18.50	1	17.62	18.50	1	16.78			
	50% RB Mid	3 Pos 1	18.50	1	17.67	18.50	1	16.80			
	50% RB High	3 Pos 2	18.50	1	17.66	18.50	1	16.81			
	100% RB	6 Pos 0	18.50	1	16.62	18.50	2	15.60			
	1RB Low	1 Pos 0	18.50	0	17.68	18.50	1	16.63			
	1RB Mid	1 Pos 2	18.50	0	17.68	18.50	1	16.63			
	1RB High	1 Pos 5	18.50	0	17.70	18.50	1	16.66			
	50% RB Low	3 Pos 0	18.50	1	17.71	18.50	1	16.84			
	50% RB Mid	3 Pos 1	18.50	1	17.66	18.50	1	16.81			
	50% RB High	3 Pos 2	18.50	1	17.69	18.50	1	16.85			
	100% RB	6 Pos 0	18.50	1	16.64	18.50	2	15.62			
	1RB Low	1 Pos 0	18.50	0	17.60	18.50	1	16.61			
	1RB Mid	1 Pos 2	18.50	0	17.61	18.50	1	16.58			
	1RB High	1 Pos 5	18.50	0	17.61	18.50	1	16.61			
	50% RB Low	3 Pos 0	18.50	1	17.66	18.50	1	16.77			
	50% RB Mid	3 Pos 1	18.50	1	17.68	18.50	1	16.81			
	50% RB High	3 Pos 2	18.50	1	17.66	18.50	1	16.80			
	100% RB	6 Pos 0	18.50	1	16.66	18.50	2	15.63			

B.2.3 LTE UL Carrier Aggregation

B.2.3.1 Intra-Band Contiguous

UL CA shall be tested based on the worst-case SAR configuration determined from non-CA SAR testing result. The UL CA mode power measurements represent the total power across both carriers.

According to November 2017 TCB workshop, the following needs to be performed: The maximum measured output power, RB allocation, CC offsets, CC channel BWs, MPR, modulation and other relevant information for all UL CA SAR configurations are required in SAR reports to support the test setup and results, including explanations, call box configurations and certain testing restriction

1) When the maximum output for UL CA is \leq standalone LTE mode

- The primary carrier is configured according to the highest standalone SAR configuration tested
- The secondary carrier and subsequent CCs are configured according to procedures used for power measurement and parameters similar to that used for the PCC

2) When the Reported SAR for UL CA configuration, is > 1.2 W/kg, UL CA SAR is also required for all the other test channels

LTE CA 5B:

Band	Antenna	Modulation / BW	PCC			SCC			Pwr Avg (dBm)	Factory Upper Tolerance (dBm)
			Ch	Freq (MHz)	RB Allocation	Ch	Freq (MHz)	RB Allocation		
LTE 5B	Main 5	QPSK / 10MHz	20476	831.6	1RB High	20575	841.5	1RB Low	19.90	20.5

LTE CA 7C:

Band	Antenna	Modulation / BW	PCC			SCC			Pwr Avg (dBm)	Factory Upper Tolerance (dBm)
			Ch	Freq (MHz)	RB Allocation	Ch	Freq (MHz)	RB Allocation		
LTE 7C	Main 5	QPSK / 20MHz	21001	2525.1	1RB High	21199	2544.9	1RB Low	13.70	14.0
	Aux 8		21001	2525.1	1RB High	21199	2544.9	1RB Low	14.00	14.0

LTE CA 38C:

Band	Antenna	Modulation / BW	PCC			SCC			Pwr Avg (dBm)	Factory Upper Tolerance (dBm)
			Ch	Freq (MHz)	RB Allocation	Ch	Freq (MHz)	RB Allocation		
LTE 38C	Main 5	QPSK / 20MHz	37901	2585.1	1RB High	38099	2604.9	1RB Low	14.44	15.0

LTE CA 41C:

Band	Antenna	Modulation / BW	PCC			SCC			Pwr Avg (dBm)	Factory Upper Tolerance (dBm)
			Ch	Freq (MHz)	RB Allocation	Ch	Freq (MHz)	RB Allocation		
LTE 41C	Aux 8	QPSK / 20MHz	40521	2583.1	1RB High	40719	2602.9	1RB Low	13.65	14.0

LTE CA 48C:

Band	Antenna	Modulation / BW	PCC			SCC			Pwr Avg (dBm)	Factory Upper Tolerance (dBm)
			Ch	Freq (MHz)	RB Allocation	Ch	Freq (MHz)	RB Allocation		
LTE 41C	Aux 8	QPSK / 20MHz	55891	3615.1	1RB High	56089	3634.9	1RB Low	14.72	15.0

LTE CA 66B, 66C:

Band	Antenna	Modulation / BW	PCC			SCC			Pwr Avg (dBm)	Factory Upper Tolerance (dBm)
			Ch	Freq (MHz)	RB Allocation	Ch	Freq (MHz)	RB Allocation		
LTE 66B	Main 5	QPSK / 10MHz	132373	1750.1	1RB High	132472	1760	1RB Low	18.45	19.0
	Aux 8	QPSK / 10MHz	132373	1750.1	1RB High	132472	1760	1RB Low	18.30	19.0
LTE 66C	Main 5	QPSK / 20MHz	132323	1745.1	1RB High	132521	1764.9	1RB Low	18.59	19.0
	Aux 8	QPSK / 20MHz	132323	1745.1	1RB High	132521	1764.9	1RB Low	18.40	19.0

B.2.3.2 Inter-Band Contiguous and ENDC

For LTE ULCA mode, each carrier transmits on separate antennas. Each exposure has been measured separately. For each, the highest standalone SAR conditions are added to derive the Total SAR. The factory upper tolerance (dBm) related to the worst-case SAR results obtained in standalone mode have been reduced by 3dB for both LTE carrier aggregation inter-band and 5G ENDC.

Band	Antenna	BW	Channel #	Freq (MHz)	% RB Allocation	RB Position	QPSK		
							Factory Upper Tolerance (dBm)	MPR	Measured Output Power (dBm)
LTE 5A	5	10 MHz	20525	836.5	1RB Mid	1 Pos 24	17.50	0	16.72
LTE 7A	8	20 MHz	21100	2535	1RB Mid	1 Pos 49	11.00	0	10.64
LTE 12A	5	10 MHz	23095	707.5	1RB Mid	1 Pos 24	16.50	0	15.54
LTE 13A	5	10 MHz	23230	782	1RB Mid	1 Pos 24	16.50	0	15.73
LTE 14A	5	10 MHz	23330	793	1RB Mid	1 Pos 24	16.50	0	15.70
LTE 25A	5	20 MHz	26365	1882.5	1RB Mid	1 Pos 49	13.50	0	12.48
LTE 25A	8	20 MHz	26365	1882.5	1RB Mid	1 Pos 49	16.00	0	15.14
LTE 26A	5	15 MHz	26865	831.5	1RB Mid	1 Pos 38	17.00	0	16.64
LTE 30A	8	10 MHz	27710	2310	1RB Mid	1 Pos 24	13.50	0	13.04
LTE 41	5	20 MHz	40620	2593	1RB Mid	1 Pos 49	13.00	0	12.23
LTE 41	8	20 MHz	40620	2593	1RB Mid	1 Pos 49	11.00	0	10.23
LTE 48A	8	20 MHz	55990	3625	1RB Mid	1 Pos 49	12.00	0	11.45
LTE 66A	5	20 MHz	132322	1745	1RB Mid	1 Pos 49	16.00	0	15.03
LTE 66A	8	20 MHz	132322	1745	1RB Mid	1 Pos 49	16.00	0	15.60

B.2.4 5G NR (FR1) Tablet Mode

B.2.4.1 5G NR (FR1) Band 2 FDD Antenna Main 5

SAR Measurement for NR Band 2 FDD (Frequency range: 1850 – 1910MHz) is covered by NR Band 25 FDD (Frequency range: 1850 – 1915MHz) due to overlapping frequency range, same maximum tune-up and same bandwidth.

B.2.4.2 5G NR (FR1) Band 2 FDD Antenna Aux 8

Band	BW (MHz)	Modulation	Mode	RB Allocation	RB Offset	Factory upper tolerance (dBm)	Measured Output Power (dBm)				
							Frequency (MHz) / Channel				
							1860	1880	1900		
							372000	376000	396000		
NR2	20	DFS-s OFDM	PI/2 BPSK	1RB Low	0	18.00		16.82			
			QPSK	1RB Low	0	18.00		16.80			
				1RB Mid	50	18.00	17.97	17.09	18.00		
				1RB High	99	18.00		17.22			
				50% RB Low	0	18.00		16.80			
				50% RB Mid	25	18.00	18.00	17.09	18.00		
				50% RB High	49	18.00		17.32			
				100% RB	0	18.00		17.04			
			16QAM	1RB Low	0	18.00		17.08			
			64QAM	1RB Low	0	18.00		16.76			
			256QAM	1RB Low	0	18.00		16.89			
			CP-OFDM	QPSK	1RB Low	0	18.00		16.91		
							Frequency (MHz) / Channel				
							1857.5	1880	1880		
							371500	376000	380500		
		15	DFS-s OFDM	QPSK	1RB Low	0	18.00		16.90		
					50% RB Low	0	18.00		16.94		
								Frequency (MHz) / Channel			
								1855	1880	1905	
								371000	376000	381000	
		10	DFS-s OFDM	QPSK	1RB Low	0	18.00		16.86		
					50% RB Low	0	18.00		16.79		
									Frequency (MHz) / Channel		
								1852.5	1880	1907.5	
							370500	376000	381500		
	5	DFS-s OFDM	QPSK	1RB Low	0	18.00		17.00			
				50% RB Low	0	18.00		17.02			

B.2.4.3 5G NR (FR1) Band 5 FDD Antenna Main 5

Band	BW (MHz)	Modulation	Mode	RB Allocation	RB Offset	Factory upper tolerance (dBm)	Measured Output Power (dBm)			
							Frequency (MHz) / Channel			
							834	836.5	839	
NR5	20	DFS-s OFDM	PI/2 BPSK	1RB Low	0	20.50	166800	167300	167800	
			QPSK	1RB Low	0	20.50		19.21		
				1RB Mid	50	20.50		19.22		
				1RB High	99	20.50		19.47		
				50% RB Low	0	20.50		19.55		
				50% RB Mid	25	20.50		19.36		
				50% RB High	49	20.50		19.51		
				100% RB	0	20.50		19.55		
			16QAM	1RB Low	0	20.50		19.47		
			64QAM	1RB Low	0	20.50		19.43		
			256QAM	1RB Low	0	20.50		18.83		
			CP-OFDM	QPSK	1RB Low	0	20.50		19.38	
							19.26			
							Frequency (MHz) / Channel			
							831.5	836.5	841.5	
							166300	167300	168300	
		15	DFS-s OFDM	QPSK	1RB Low	0	20.50		19.21	
	50% RB Low				0	20.50		19.22		
								Frequency (MHz) / Channel		
								829	836.5	844
								165800	167300	168800
		10	DFS-s OFDM	QPSK	1RB Low	0	20.50		19.24	
	50% RB Low				0	20.50		19.22		
								Frequency (MHz) / Channel		
								826.5	836.5	846.5
								165300	167300	169300
		5	DFS-s OFDM	QPSK	1RB Low	0	20.50		19.33	
50% RB Low	0				20.50		19.41			

B.2.4.4 5G NR (FR1) Band 7 FDD Antenna Main 5

Band	BW (MHz)	Modulation	Mode	RB Allocation	RB Offset	Factory upper tolerance (dBm)	Measured Output Power (dBm)					
							Frequency (MHz) / Channel					
							2510	2535	2560			
NR7	20	DFS-s OFDM	PI/2 BPSK	1RB Low	0	14.00	502000	13.43	512000			
			QPSK	1RB Low	0	14.00		13.41				
				1RB Mid	50	14.00	14.00	14.00				
				1RB High	99	14.00	13.30	14.00				
				50% RB Low	0	14.00			13.42			
				50% RB Mid	25	14.00	14.00	13.39	14.00			
				50% RB High	49	14.00	13.44	14.00				
				100% RB	0	14.00			14.00			
			16QAM	1RB Low	0	14.00			13.67			
			64QAM	1RB Low	0	14.00	13.12					
			256QAM	1RB Low	0	14.00	13.57					
			CP-OFDM	QPSK	1RB Low	0	14.00	13.51				
										Frequency (MHz) / Channel		
										2507.5	2535	2562.5
								501500	507000	512500		
	15	DFS-s OFDM	QPSK	1RB Low	0	14.00	13.46	13.43				
				50% RB Low	0	14.00						
								Frequency (MHz) / Channel				
								2505	2535	2565		
								501000	507000	513000		
	10	DFS-s OFDM	QPSK	1RB Low	0	14.00	13.28	13.24				
				50% RB Low	0	14.00						
								Frequency (MHz) / Channel				
								2502.5	2535	2567.5		
								500500	507000	513500		
	5	DFS-s OFDM	QPSK	1RB Low	0	14.00	13.37	13.36				
				50% RB Low	0	14.00						

B.2.4.5 5G NR (FR1) Band 25 FDD Antenna Main 5

Band	BW (MHz)	Modulation	Mode	RB Allocation	RB Offset	Factory upper tolerance (dBm)	Measured Output Power (dBm) Antenna 5				
							Frequency (MHz) / Channel				
							1860	1882.5	1905		
NR25	20	DFS-s OFDM	PI/2 BPSK	1RB Low	0	16.50	372000	376500	381000		
			QPSK	1RB Low	0	16.50		15.57			
				1RB Mid	50	16.50	16.50	15.56			
				1RB High	99	16.50		15.79	16.50		
				50% RB Low	0	16.50		15.79			
				50% RB Mid	25	16.50	16.50	15.46			
				50% RB High	49	16.50		15.82	16.50		
				100% RB	0	16.50		15.85			
			16QAM	1RB Low	0	16.50		15.67			
			64QAM	1RB Low	0	16.50		15.75			
			256QAM	1RB Low	0	16.50		15.13			
			CP-OFDM	QPSK	1RB Low	0	16.50		15.82		
									15.66		
									Frequency (MHz) / Channel		
							1857.5	1882.5	1907.5		
							371500	376500	381500		
	15	DFS-s OFDM	QPSK	1RB Low	0	16.50		15.66			
				50% RB Low	0	16.50		15.68			
									Frequency (MHz) / Channel		
									1855	1882.5	1910
							371000	376500	382000		
	10	DFS-s OFDM	QPSK	1RB Low	0	16.50		15.62			
				50% RB Low	0	16.50		15.52			
								Frequency (MHz) / Channel			
								1852.5	1882.5	1912.5	
								370500	376500	382500	
	5	DFS-s OFDM	QPSK	1RB Low	0	16.50		15.81			
				50% RB Low	0	16.50		15.80			

B.2.4.6 5G NR (FR1) Band 30 FDD Antenna 5

Band	BW (MHz)	Modulation	Mode	RB Allocation	RB Offset	Factory upper tolerance (dBm)	Measured Output Power (dBm)			
							Frequency (MHz) / Channel			
NR30	10	DFS-s OFDM	PI/2 BPSK	1RB Low	0	18.00	2310	46200		
			QPSK	1RB Low	0	18.00			17.04	
				1RB Mid	25	18.00			17.09	
				1RB High	49	18.00			17.16	
				50% RB Low	0	18.00			17.13	
				50% RB Mid	12	18.00			16.93	
				50% RB High	25	18.00			17.13	
				100% RB	0	18.00			17.01	
			16QAM	1RB Low	0	18.00			17.32	
			64QAM	1RB Low	0	18.00			16.61	
			256QAM	1RB Low	0	18.00			17.35	
			CP-OFDM	QPSK	1RB Low	0			18.00	17.14
										Frequency (MHz) / Channel
								2310		
								46200		
	5	DFS-s OFDM	QPSK	1RB Low	0	18.00	2310	46200		
				50% RB Low	0	18.00			17.33	
							17.35			

B.2.4.9 5G NR (FR1) Band 41 TDD Antenna Main 5

Band	BW (MHz)	Modulation	Mode	RB Allocation	RB Offset	Factory upper tolerance (dBm)	Measured Output Power (dBm)					
							Frequency (MHz) / Channel					
							2546	2569.5	2593	2616.5	2640	
NR41	100	DFS-s OFDM	PI/2 BPSK	1RB Low	0	15.00	509200	513900	518598	523300	528000	13.42
			QPSK	1RB Low	0	15.00						13.44
				1RB Mid	136	15.00						13.91
				1RB High	270	15.00						14.53
				50% RB Low	0	15.00						14.04
				50% RB Mid	68	15.00						14.39
				50% RB High	137	15.00						14.82
				100% RB	0	15.00						14.37
			16QAM	1RB Low	0	15.00						13.76
			64QAM	1RB Low	0	15.00						13.64
		256QAM	1RB Low	0	15.00	13.66						
		CP-OFDM	QPSK	1RB Low	0	15.00						13.37
												Frequency (MHz) / Channel
								2541	2567	2593	2619	2645
								508200	513400	518598	523800	529000
	90	DFS-s OFDM	QPSK	1RB Low	0	15.00						13.43
				50% RB Low	0	15.00						14.05
								Frequency (MHz) / Channel				
								2536	2564.5	2593	2621.5	2650
								507200	512900	518598	524300	530000
	80	DFS-s OFDM	QPSK	1RB Low	0	15.00						13.55
				50% RB Low	0	15.00						14.15
								Frequency (MHz) / Channel				
								2526	2559.5	2593	2626.5	2660
								505200	511900	518598	525300	532000
	60	DFS-s OFDM	QPSK	1RB Low	0	15.00						13.80
				50% RB Low	0	15.00						14.00
								Frequency (MHz) / Channel				
							2521	2557	2593	2629	2665	
							504200	511400	518598	525800	5330000	
50	DFS-s OFDM	QPSK	1RB Low	0	15.00						13.76	
			50% RB Low	0	15.00						14.04	
							Frequency (MHz) / Channel					
							2516	2554.5	2593	2631.5	2670	
							503200	510900	518598	526300	534000	
40	DFS-s OFDM	QPSK	1RB Low	0	15.00						13.48	
			50% RB Low	0	15.00						13.93	
							Frequency (MHz) / Channel					
							2506	2549.5	2593	2636.5	2680	
							501200	509900	518598	527300	536000	
20	DFS-s OFDM	QPSK	1RB Low	0	15.00						14.04	
			50% RB Low	0	15.00						14.10	

B.2.4.10 5G NR (FR1) Band 41 TDD Antenna Aux 8

Band	BW	Modulation	Mode	RB Allocation	RB Offset	Factory upper tolerance (dBm)	Measured Output Power (dBm)					
							Frequency (MHz) / Channel					
							2546	2569.5	2593	2616.5	2640	
							509200	513900	518598	523300	528000	
100	DFS-s OFDM	PI/2 BPSK	1RB Low	0	14.00				12.75			
			1RB Low	0	14.00				12.76			
		QPSK	1RB Mid	136	14.00				12.88			
			1RB High	270	14.00				12.65			
			50% RB Low	0	14.00				13.26			
			50% RB Mid	68	14.00				13.28			
			50% RB High	137	14.00				13.39			
		100% RB	0	14.00				13.26				
		16QAM	1RB Low	0	14.00				13.15			
		64QAM	1RB Low	0	14.00				12.78			
256QAM	1RB Low	0	14.00				13.05					
CP-OFDM	QPSK	1RB Low	0	14.00				12.83				
							Frequency (MHz) / Channel					
							2541	2567	2593	2619	2645	
							508200	513400	518598	523800	529000	
90	DFS-s OFDM	QPSK	1RB Low	0	14.00				12.88			
			50% RB Low	0	14.00				13.21			
							Frequency (MHz) / Channel					
							2536	2564.5	2593	2621.5	2650	
							507200	512900	518598	524300	530000	
80	DFS-s OFDM	QPSK	1RB Low	0	14.00				13.03			
			50% RB Low	0	14.00				13.29			
							Frequency (MHz) / Channel					
							2526	2559.5	2593	2626.5	2660	
							505200	511900	518598	525300	532000	
60	DFS-s OFDM	QPSK	1RB Low	0	14.00				13.32			
			50% RB Low	0	14.00				13.24			
							Frequency (MHz) / Channel					
							2521	2557	2593	2629	2665	
							504200	511400	518598	525800	5330000	
50	DFS-s OFDM	QPSK	1RB Low	0	14.00				13.13			
			50% RB Low	0	14.00				13.20			
							Frequency (MHz) / Channel					
							2516	2554.5	2593	2631.5	2670	
							503200	510900	518598	526300	534000	
40	DFS-s OFDM	QPSK	1RB Low	0	14.00				12.77			
			50% RB Low	0	14.00				13.16			
							Frequency (MHz) / Channel					
							2506	2549.5	2593	2636.5	2680	
							501200	509900	518598	527300	536000	
20	DFS-s OFDM	QPSK	1RB Low	0	14.00				12.92			
			50% RB Low	0	14.00				13.11			

B.2.4.13 5G NR (FR1) Band 77 TDD Antenna Main 5

Band	BW	Modulation	Mode	RB Allocation	RB Offset	Factory upper tolerance (dBm)	Measured Output Power (dBm)						
							Frequency (MHz) / Channel						
							3840	3795	3750	3885	3930		
							656600	653000	650000	659000	662000		
NR77	100	DFS-s OFDM	PI/2 BPSK	1RB Low	0	16.00			15.03				
			QPSK	1RB Low	0	16.00			15.14				
				1RB Mid	136	16.00			15.40				
				1RB High	270	16.00			15.13				
				50% RB Low	0	16.00			15.51				
				50% RB Mid	68	16.00			15.74				
				50% RB High	137	16.00			15.67				
				100% RB	0	16.00			15.59				
			16QAM	1RB Low	0	16.00			15.41				
			64QAM	1RB Low	0	16.00			14.96				
		256QAM	1RB Low	0	16.00			15.21					
		CP-OFDM	QPSK	1RB Low	0	16.00			15.03				
									Frequency (MHz) / Channel				
									3840	3795	3750	3885	3930
							656600	653000	650000	659000	662000		
90	DFS-s OFDM	QPSK	1RB Low	0	16.00			15.22					
			50% RB Low	0	16.00			15.52					
							Frequency (MHz) / Channel						
							3840	3795	3750	3885	3930		
							656600	653000	650000	659000	662000		
80	DFS-s OFDM	QPSK	1RB Low	0	16.00			15.30					
			50% RB Low	0	16.00			15.60					
							Frequency (MHz) / Channel						
							3840	3795	3750	3885	3930		
							656600	653000	650000	659000	662000		
60	DFS-s OFDM	QPSK	1RB Low	0	16.00			15.49					
			50% RB Low	0	16.00			15.60					
							Frequency (MHz) / Channel						
							3840	3795	3750	3885	3930		
							656600	653000	650000	659000	662000		
50	DFS-s OFDM	QPSK	1RB Low	0	16.00			15.41					
			50% RB Low	0	16.00			15.62					
							Frequency (MHz) / Channel						
							3840	3795	3750	3885	3930		
							656600	653000	650000	659000	662000		
40	DFS-s OFDM	QPSK	1RB Low	0	16.00			15.00					
			50% RB Low	0	16.00			15.60					
							Frequency (MHz) / Channel						
							3840	3795	3750	3885	3930		
							656600	653000	650000	659000	662000		
20	DFS-s OFDM	QPSK	1RB Low	0	16.00			15.24					
			50% RB Low	0	16.00			15.62					

B.3 Tissue Parameters Measurement

Body TSL SAR System #2

Body TSL	Target TSL		Measured TSL		Deviation %		Date
Freq (MHz)	ϵ' (F/m)	σ (S/m)	ϵ' (F/m)	σ (S/m)	Deviation ϵ'	Deviation σ	
750	55.53	0.96	53.48	0.94	-3.69	-2.08	2021-11-22
830	55.19	0.98	53.24	0.98	55.19	0.00	2021-11-22
1750	53.43	1.49	51.23	1.4	-4.12	-6.04	2021-11-25
1900	53.3	1.52	51.04	1.58	-4.24	3.95	2021-11-22
1900	53.3	1.52	50.97	1.51	-4.37	-0.66	2021-11-25
2300	52.9	1.81	50.53	1.9	-4.48	4.97	2021-11-22
2600	52.51	2.16	50.41	2.13	-4.0	-1.39	2021-11-29
3700	51.05	3.55	48.27	3.38	-5.45	-4.79	2021-11-22

Body TSL SAR System #4

Body TSL	Target TSL		Measured TSL		Deviation %		Date
Freq (MHz)	ϵ' (F/m)	σ (S/m)	ϵ' (F/m)	σ (S/m)	Deviation ϵ'	Deviation σ	
830	55.23	0.98	53.19	0.93	-3.69	-5.10	2021-11-16
1750	53.43	1.49	51.92	1.41	-2.83	-5.37	2021-11-16
1750	53.43	52.12	1.53	-2.21	0.66	-5.37	2021-11-25
1900	53.30	1.52	51.58	1.50	-3.23	-1.32	2021-11-16
2300	52.90	1.81	51.12	1.81	-3.36	0.00	2021-11-16
2600	52.51	2.16	50.13	2.19	-4.53	1.39	2021-11-22
2600	52.51	2.16	50.72	2.10	-3.41	-2.78	2021-11-16
3700	51.05	3.55	47.98	3.29	-6.01	-7.32	2021-12-02

See *Annex D* below for more details.

B.3.1 System Check Measurements

Body Measurements SAR System #2

Frequency (MHz)	Average	Target SAR (W/Kg)	Measured SAR (W/Kg)	Deviation to target (%)	Limit (%)	Date
750	1g	8.46	8.04	-4.96	±10	2021-11-23
	10g	5.59	5.12	-8.41		2021-11-23
835	1g	9.63	9.10	-5.50		2021-11-23
	10g	6.31	6.00	-4.91		2021-11-24
1750	1g	36.80	34.20	-7.07		2021-11-24
	10g	19.40	18.40	-5.15		2021-11-25
	1g	36.80	33.60	-8.70		2021-11-25
	10g	19.40	18.06	-6.91		2021-11-24
1900	1g	39.50	37.80	-4.30		2021-11-24
	10g	20.70	19.92	-3.77		2021-11-25
	1g	39.50	36.80	-6.84		2021-11-25
	10g	20.70	19.44	-6.09		2021-11-23
2300	1g	47.20	47.20	0.00		2021-11-23
	10g	22.60	22.60	0.00		2021-11-22
2600	1g	54.60	58.60	7.33		2021-11-22
	10g	24.20	25.60	5.79		2021-11-23
	1g	54.60	51.60	-5.49	2021-11-23	
	10g	24.20	23.20	-4.13	2021-11-24	
3700	1g	62.10	59.80	-3.70	2021-11-24	
	10g	22.20	22.00	-0.90		

Body Measurements SAR System #4

Frequency (MHz)	Average	Target SAR (W/Kg)	Measured SAR (W/Kg)	Deviation to target (%)	Limit (%)	Date	
835	1g	9.63	9.78	1.56	±10	2021-11-17	
	10g	6.31	6.40	1.43			
1750	1g	36.80	35.80	-2.72		2021-11-17	
	10g	19.40	19.04	-1.86			
1900	1g	39.50	40.20	1.77		2021-11-16	
	10g	20.70	21.00	1.45			
2300	1g	47.20	47.00	-0.42		2021-11-17	
	10g	22.60	22.20	-1.77			
2600	1g	54.60	51.80	-5.13		2021-11-17	
	10g	24.20	23.00	-4.96			
	1g	54.60	51.80	-5.13			2021-11-16
	10g	24.20	23.00	-4.96			
	1g	54.60	52.40	-4.03			2021-12-03
	10g	24.20	23.40	-3.31			
3700	1g	62.10	59.80	-3.70	2021-12-03		
	10g	22.20	22.00	-0.90			

See Annex C for more details.

B.4 SAR Tablet Test Results

B.4.1 WCDMA

Radio Band Name	Antenna	BW (MHz)	Rate	Channel Number	Freq (MHz)	Position	Scaling Factor (dB)	Measured SAR 1g (W/Kg)	Reported SAR 1g (W/Kg)	Plot #
Band II	Main 5	2	RMC 12.2kbps	9262	1852.4	Top edge	0.56	0.67	0.76	
				9400	1880	Back Face	0.54	0.02	0.03	
						Right Edge	0.54	0.30	0.33	
						Top edge	0.54	0.74	0.83	
9538	1907.6	Top edge	0.60	0.84	0.97	1				

Radio Band Name	Antenna	BW (MHz)	Rate	Channel Number	Freq (MHz)	Position	Scaling Factor (dB)	Measured SAR 1g (W/Kg)	Reported SAR 1g (W/Kg)	Plot #
Band IV	Main 5	5	RMC 12.2kbps	1312	1712.4	Top edge	0.23	0.89	0.94	2
				1413	1732.6	Back Face	0.35	0.02	0.02	
						Right Edge	0.35	0.32	0.34	
						Top edge	0.35	0.87	0.94	
1513	1752.6	Top edge	0.36	0.86	0.93					

Radio Band Name	Antenna	BW (MHz)	Rate	Channel Number	Freq (MHz)	Position	Scaling Factor (dB)	Measured SAR 1g (W/Kg)	Reported SAR 1g (W/Kg)	Plot #
Band V	Main 5	5	RMC 12.2kbps	4132	826.4	Top edge	0.45	0.86	0.95	3
				4183	836.6	Back Face	0.53	0.07	0.08	
						Right Edge	0.53	0.10	0.12	
						Top edge	0.53	0.79	0.89	
4183	836.6	Top edge	0.51	0.75	0.84					

B.4.2 LTE

B.4.2.1 LTE Band 5 FDD

Band	Ant	BW (MHz)	Mod.	Channel Number	Freq (MHz)	Position	% RB Allocation	Scaling Factor (dB)	Measured SAR 1g (W/Kg)	Reported SAR 1g (W/Kg)	Plot #
Band 5	Main 5	10	QPSK	20525	836.6	Back Face	1RB Mid	1.00	0.07	0.08	
							50RB Mid	1.05	0.05	0.07	
						Right Edge	1RB Mid	1.00	0.09	0.12	
							50RB Mid	1.05	0.07	0.09	
						Top edge	1RB Mid	0.99	0.91	1.16	4
							50RB Mid	1.05	0.71	0.91	
100RB Mid	0.99	0.73	0.91								

UL CA 5B

UL CA shall be tested based on the worst-case SAR configuration determined from standalone mode SAR testing result.

The channel BW, channel number, RB allocation, etc. would be selected to allow contiguous CA of PCC and SCC. Uplink output power for UL CA is the total power measured across the PCC and SCC.

Standalone testing in LTE Band5 is not required since Back Face is covered by LTE Band26. Top Edge position with low channel is chosen as the configuration that gives the highest SAR, thus, the same is used for UL CA testing T

Band	Antenna	Modulation / BW	PCC			SCC			Position	Scaling Factor (dB)	Measured SAR 1g (W/Kg)	Reported SAR 1g (W/Kg)
			Ch	Freq (MHz)	RB Allocation	Ch	Freq (MHz)	RB Allocation				
LTE 5B	Main 5	QPSK / 10MHz	20476	831.6	1RB High	20575	841.5	1RB Low	Top Edge	0.60	0.69	0.79

PCC RB allocation settings for UL CA have been adjusted based on the worst-case power

LTE Band 5 for UL CA 5A Inter-band and ENDC

Band	Ant	BW (MHz)	Mod.	Channel Number	Freq (MHz)	Position	% RB Allocation	Scaling Factor (dB)	Measured SAR 1g (W/Kg)	Reported SAR 1g (W/Kg)
Band 5	Main 5	10	QPSK	20525	836.6	Top edge	1RB Mid	0.78	0.33	0.39

B.4.2.2 LTE Band 7 FDD

Band	Ant	BW (MHz)	Mod.	Channel Number	Freq (MHz)	Position	% RB Allocation	Scaling Factor (dB)	Measured SAR 1g (W/Kg)	Reported SAR 1g (W/Kg)	Plot #
Band 7	Main 5	20	QPSK	20850	2510	Top edge	1RB Mid	0.30	1.18	1.26	
							50RB Mid	0.34	0.94	1.02	
				21100	2535	Back Face	1RB Mid	0.29	0.02	0.02	
							50RB Mid	0.34	0.02	0.02	
						Right Edge	1RB Mid	0.29	0.08	0.08	
							50RB Mid	0.34	0.06	0.06	
				Top edge	1RB Mid	0.29	1.32	1.41	5		
					50RB Mid	0.34	1.05	1.14			
	21350	2560	Top edge	1RB Mid	0.25	0.87	0.92				
				50RB Mid	0.38	0.69	0.75				
	Main 8	20	QPSK	20850	2510	Top edge	1RB Mid	0.24	0.77	0.82	
							50RB Mid	0.31	0.61	0.65	
				21100	2535	Back Face	1RB Mid	0.27	0.02	0.02	
							50RB Mid	0.21	0.02	0.02	
						Top edge	1RB Mid	0.27	0.89	0.95	
							50RB Mid	0.21	0.70	0.73	
100RB Mid				0.29	0.67	0.72					
				21350	2560	Top edge	1RB Mid	0.11	0.88	0.90	
50RB Mid	0.21	0.69	0.73								

UL CA 7C

UL CA shall be tested based on the worst-case SAR configuration determined from non-CA SAR testing result. The channel BW, channel number, RB allocation, etc. would be selected to allow contiguous CA of PCC and SCC. Uplink output power for UL CA is the total power measured across the PCC and SCC.

From the above table on standalone testing on LTE Band7, Laptop position with low channel is chosen as the configuration that gives the highest SAR, thus, the same is used for UL CA testing

Band	Antenna	Modulation / BW	PCC			SCC			Position	Scaling Factor (dB)	Measured SAR 1g (W/Kg)	Reported SAR 1g (W/Kg)
			Ch	Freq (MHz)	RB Allocation	Ch	Freq (MHz)	RB Allocation				
LTE 7C	Main 5	QPSK / 20MHz	2100 1	2525.1	1RB High	21199	2544.9	1RB Low	Top Edge	0.30	1.21	1.30
	Aux 8	QPSK / 20MHz	2100 1	2525.1	1RB High	21199	2544.9	1RB Low	Top Edge	0.00	0.93	0.93

PCC RB allocation settings for UL CA have been adjusted based on the worst-case power

LTE Band 7 for UL CA 7A Inter-band and ENDC

Band	Ant	BW (MHz)	Mod.	Channel Number	Freq (MHz)	Position	% RB Allocation	Scaling Factor (dB)	Measured SAR 1g (W/Kg)	Reported SAR 1g (W/Kg)
Band 7	Aux 8	20	QPSK	20525	836.6	Top edge	1RB Mid	0.36	0.45	0.49

B.4.2.3 LTE Band 12 FDD

Band	Ant	BW (MHz)	Mod.	Channel Number	Freq (MHz)	Position	% RB Allocation	Scaling Factor (dB)	Measured SAR 1g (W/Kg)	Reported SAR 1g (W/Kg)	Plot #
Band 12	Main 5	10	QPSK	23095	707.5	Back Face	1RB Mid	1.04	0.08	0.10	
							50RB Mid	1.07	0.06	0.08	
						Right Edge	1RB Mid	1.04	0.05	0.07	
							50RB Mid	1.07	0.04	0.05	
						Top edge	1RB Mid	1.04	0.87	1.10	6
							50RB Mid	1.07	0.69	0.88	
100RB Mid	1.03	0.69	0.87								

LTE Band 12 for UL CA 12A Inter-band and ENDC

Band	Ant	BW (MHz)	Mod.	Channel Number	Freq (MHz)	Position	% RB Allocation	Scaling Factor (dB)	Measured SAR 1g (W/Kg)	Reported SAR 1g (W/Kg)
Band 12A	Main 5	10	QPSK	23095	707.5	Top edge	1RB Mid	0.96	0.31	0.39

B.4.2.4 LTE Band 13 FDD

Band	Ant	BW (MHz)	Mod.	Channel Number	Freq (MHz)	Position	% RB Allocation	Scaling Factor (dB)	Measured SAR 1g (W/Kg)	Reported SAR 1g (W/Kg)	Plot #
Band 13	Main 5	10	QPSK	23230	782	Back Face	1RB Mid	0.85	0.08	0.09	
							50RB Mid	0.92	0.06	0.07	
						Right Edge	1RB Mid	0.85	0.06	0.08	
							50RB Mid	0.92	0.05	0.06	
						Top edge	1RB Mid	0.85	1.00	1.23	7
							50RB Mid	0.92	0.78	0.96	
100RB Mid	0.94	0.78	0.97								

LTE Band 13 for UL CA 13A Inter-band and ENDC

Band	Ant	BW (MHz)	Mod.	Channel Number	Freq (MHz)	Position	% RB Allocation	Scaling Factor (dB)	Measured SAR 1g (W/Kg)	Reported SAR 1g (W/Kg)
Band 13A	Main 5	10	QPSK	23230	782	Top edge	1RB Mid	0.77	0.37	0.44

B.4.2.5 LTE Band 14 FDD

Band	Ant	BW (MHz)	Mod.	Channel Number	Freq (MHz)	Position	% RB Allocation	Scaling Factor (dB)	Measured SAR 1g (W/Kg)	Reported SAR 1g (W/Kg)	Plot #
Band 14	Main 5	10	QPSK	23330	793	Back Face	1RB Mid	0.94	0.07	0.08	
							50RB Mid	0.97	0.05	0.06	
						Right Edge	1RB Mid	0.94	0.07	0.08	
							50RB Mid	0.97	0.05	0.07	
						Top edge	1RB Mid	0.94	0.97	1.22	8
							50RB Mid	0.97	0.76	0.95	
100RB Mid	0.91	0.75	0.92								

LTE Band 14 for UL CA 14A Inter-band and ENDC

Band	Ant	BW (MHz)	Mod.	Channel Number	Freq (MHz)	Position	% RB Allocation	Scaling Factor (dB)	Measured SAR 1g (W/Kg)	Reported SAR 1g (W/Kg)
Band 14A	Main 5	10	QPSK	23330	793	Top edge	1RB Mid	0.80	0.35	0.43

B.4.2.6 LTE Band 25 FDD

Band	Ant	BW (MHz)	Mod.	Channel Number	Freq (MHz)	Position	% RB Allocation	Scaling Factor (dB)	Measured SAR 1g (W/Kg)	Reported SAR 1g (W/Kg)	Plot #
Band 25	Main 5	20	QPSK	26140	1860	Top edge	1RB Mid	0.41	0.69	0.76	
							50RB Mid	0.43	0.55	0.60	
				26365	1882.5	Back Face	1RB Mid	0.52	0.06	0.07	
							50RB Mid	0.40	0.05	0.06	
						Right Edge	1RB Mid	0.52	0.06	0.07	
							50RB Mid	0.40	0.05	0.05	
				Top edge	1RB Mid	0.52	0.76	0.85			
					50RB Mid	0.40	0.61	0.67			
	26590	1905	Top edge	1RB Mid	0.40	0.89	0.98				
				50RB Mid	0.40	0.72	0.79				
	Aux 8	20	QPSK	26140	1860	Top edge	1RB Mid	1.12	0.46	0.59	
							50RB Mid	1.10	0.69	0.88	
				26365	1882.5	Back Face	1RB Mid	1.12	0.06	0.08	
							50RB Mid	1.04	0.05	0.06	
						Top edge	1RB Mid	1.16	0.84	1.09	9
							50RB Mid	1.04	0.67	0.85	
100RB Mid				1.16	0.63	0.83					
				26590	1905	Top edge	1RB Mid	1.08	0.84	1.07	
50RB Mid	1.04	0.68	0.86								

LTE Band 25 for UL CA 25A Inter-band and ENDC

Band	Ant	BW (MHz)	Mod.	Channel Number	Freq (MHz)	Position	% RB Allocation	Scaling Factor (dB)	Measured SAR 1g (W/Kg)	Reported SAR 1g (W/Kg)
Band 25A	Main 5	20	QPSK	23330	793	Top edge	1RB Mid	0.52	0.37	0.42
	Aux 8	20	QPSK	23330	793	Top edge	1RB Mid	0.86	0.39	0.48

B.4.2.7 LTE Band 26 FDD

Band	Ant	BW (MHz)	Mod.	Channel Number	Freq (MHz)	Position	% RB Allocation	Scaling Factor (dB)	Measured SAR 1g (W/Kg)	Reported SAR 1g (W/Kg)	Plot #
Band 26	Main 5	15	QPSK	26865	831.5	Back Face	1RB Mid	0.39	0.07	0.08	
							50RB Mid	0.48	0.06	0.06	
						Right Edge	1RB Mid	0.39	0.07	0.08	
							50RB Mid	0.48	0.06	0.07	
						Top edge	1RB Mid	0.39	0.72	0.79	10
							50RB Mid	0.48	0.57	0.63	

LTE Band 26 for UL CA 26A Inter-band and ENDC

Band	Ant	BW (MHz)	Mod.	Channel Number	Freq (MHz)	Position	% RB Allocation	Scaling Factor (dB)	Measured SAR 1g (W/Kg)	Reported SAR 1g (W/Kg)
Band 26A	Main 5	20	QPSK	26865	831.5	Top edge	1RB Mid	0.36	0.33	0.36

B.4.2.8 LTE Band 30 FDD

Band	Ant	BW (MHz)	Mod.	Channel Number	Freq (MHz)	Position	% RB Allocation	Scaling Factor (dB)	Measured SAR 1g (W/Kg)	Reported SAR 1g (W/Kg)	Plot #
Band 30	Main 5	10	QPSK	27710	2310	Back Face	1RB Mid	0.54	0.06	0.07	
							50RB Mid	0.67	0.05	0.05	
						Right Edge	1RB Mid	0.54	0.02	0.02	
							50RB Mid	0.67	0.01	0.02	
						Top edge	1RB Mid	0.54	0.57	0.64	
							50RB Mid	0.67	0.44	0.52	
	Main 8	10	QPSK	27710	2310	Back Face	1RB Mid	0.39	0.06	0.06	
							50RB Mid	0.52	0.05	0.05	
						Top edge	1RB Mid	0.39	0.95	1.04	11
							50RB Mid	0.52	0.73	0.82	
100RB Mid	0.59	0.71	0.82								

LTE Band 30 for UL CA 30A Inter-band and ENDC

Band	Ant	BW (MHz)	Mod.	Channel Number	Freq (MHz)	Position	% RB Allocation	Scaling Factor (dB)	Measured SAR 1g (W/Kg)	Reported SAR 1g (W/Kg)
Band 30A	Aux 8	10	QPSK	27710	2310	Top edge	1RB Mid	0.46	0.39	0.43

B.4.2.9 LTE Band 41 TDD

Band	Ant	BW (MHz)	Mod.	Channel Number	Freq (MHz)	Position	% RB Allocation	Scaling Factor (dB)	Measured SAR 1g (W/Kg)	Reported SAR 1g (W/Kg)	Plot #
Band 41	Main 5	20	QPSK	40620	2593	Back Face	1RB Mid	1.82	0.03	0.05	
							50RB Mid	1.78	0.08	0.12	
						Right Edge	1RB Mid	1.82	0.01	0.01	
							50RB Mid	1.78	0.02	0.02	
						Top edge	1RB Mid	1.82	0.38	0.58	
							50RB Mid	1.78	0.32	0.48	
	Main 8	20	QPSK	40620	2593	Back Face	1RB Mid	0.69	0.03	0.04	
							50RB Mid	0.71	0.08	0.09	
						Top edge	1RB Mid	0.69	0.66	0.77	12
							50RB Mid	0.71	0.54	0.63	

UL CA 41C

UL CA shall be tested based on the worst-case SAR configuration determined from non-CA SAR testing result. The channel BW, channel number, RB allocation, etc. would be selected to allow contiguous CA of PCC and SCC. Uplink output power for UL CA is the total power measured across the PCC and SCC.

From the above table on standalone testing on LTE Band41, Back Face position on antenna5 and Laptop on antenna8 are chosen as the configurations that give the highest SAR, thus, the same is used for UL CA testing

Band	Antenna	Modulation / BW	PCC			SCC			Position	Scaling Factor (dB)	Measured SAR 1g (W/Kg)	Reported SAR 1g (W/Kg)
			Ch	Freq (MHz)	RB Allocation	Ch	Freq (MHz)	RB Allocation				
LTE 41C	Aux 8	QPSK / 20MHz	40521	2583.1	1RB High	40719	2602.9	1RB Low	Top Edge	0.35	0.44	0.47

PCC RB allocation settings for UL CA have been adjusted based on the worst-case power

LTE Band 41 for UL CA 41A Inter-band and ENDC

Band	Ant	BW (MHz)	Mod.	Channel Number	Freq (MHz)	Position	% RB Allocation	Scaling Factor (dB)	Measured SAR 1g (W/Kg)	Reported SAR 1g (W/Kg)
Band 41	Main 5	20	QPSK	40620	2593	Top edge	1RB Mid	0.77	0.15	0.17
	Aux 8	20	QPSK	40620	2593	Top edge	1RB Mid	0.77	0.14	0.16

B.4.2.10 LTE Band 48 TDD

Band	Ant	BW (MHz)	Distance (mm)	Channel Number	Freq (MHz)	Position	% RB Allocation	Scaling Factor (dB)	Measured SAR 1g (W/Kg)	Reported SAR 1g (W/Kg)	Plot #
Band 48	Main 8	20	0	55990	3625	Back Face	1RB Mid	0.09	0.04	0.04	
							50RB Mid	0.04	0.04	0.04	
						Top edge	1RB Mid	0.09	0.35	0.36	13
							50RB Mid	0.04	0.29	0.29	

UL CA 48C

UL CA shall be tested based on the worst-case SAR configuration determined from non-CA SAR testing result. The channel BW, channel number, RB allocation, etc. would be selected to allow contiguous CA of PCC and SCC. Uplink output power for UL CA is the total power measured across the PCC and SCC.

From the above table on standalone testing on LTE Band48, Back Face position on antenna5 and Laptop on antenna8 are chosen as the configurations that give the highest SAR, thus, the same is used for UL CA testing

Band	Antenna	Modulation / BW	PCC			SCC			Position	Scaling Factor (dB)	Measured SAR 1g (W/Kg)	Reported SAR 1g (W/Kg)
			Ch	Freq (MHz)	RB Allocation	Ch	Freq (MHz)	RB Allocation				
LTE 48C	Aux 8	QPSK / 20MHz	55891	3615.1	1RB High	56089	3634.9	1RB Low	Top Edge	0.28	0.31	0.33

PCC RB allocation settings for UL CA have been adjusted based on the worst-case power

LTE Band 48 for UL CA 48 Inter-band and ENDC

Band	Ant	BW (MHz)	Mod.	Channel Number	Freq (MHz)	Position	% RB Allocation	Scaling Factor (dB)	Measured SAR 1g (W/Kg)	Reported SAR 1g (W/Kg)
Band 48	Aux 8	20	QPSK	55990	3625	Top edge	1RB Mid	0.55	0.15	0.17

B.4.2.11 LTE Band 66 FDD

Band	Ant	BW (MHz)	Distance (mm)	Channel Number	Freq (MHz)	Position	% RB Allocation	Scaling Factor (dB)	Measured SAR 1g (W/Kg)	Reported SAR 1g (W/Kg)	Plot #
Band 66	Main 5	20	0	132072	1720	Top edge	1RB Mid	1.04	0.72	0.92	
							50RB Mid	1.07	0.58	0.74	
				132322	Back Face	1RB Mid	1.04	0.09	0.12		
						50RB Mid	1.04	0.08	0.10		
					Right Edge	1RB Mid	1.04	0.11	0.14		
						50RB Mid	1.04	0.08	0.11		
					Top edge	1RB Mid	1.04	0.73	0.92		
						50RB Mid	1.04	0.58	0.74		
				132572	1770	Top edge	1RB Mid	0.99	0.75	0.94	14
							50RB Mid	1.05	0.60	0.76	
	Main 8	20	0	132322	1745	Back Face	1RB Mid	1.31	0.09	0.12	
							50RB Mid	1.26	0.07	0.10	
						Top edge	1RB Mid	1.31	0.55	0.74	
							50RB Mid	1.26	0.43	0.57	

UL CA 66B, 66C

UL CA shall be tested based on the worst-case SAR configuration determined from non-CA SAR testing result. The channel BW, channel number, RB allocation, etc. would be selected to allow contiguous CA of PCC and SCC. Uplink output power for UL CA is the total power measured across the PCC and SCC.

From the above table on standalone testing on LTE Band66, Laptop position in the low channel is chosen as the configurations that gives the highest SAR, thus, the same is used for UL CA testing for the 66C mode. Since the 10MHz was not tested in standalone, due to KDB 941225 reduction list, the initial configuration for the 66B mode was taken from the worst-case scenario of the 20MHz

Band	Antenna	Modulation / BW	PCC			SCC			Position	Scaling Factor (dB)	Measured SAR 1g (W/Kg)	Reported SAR 1g (W/Kg)
			Ch	Freq (MHz)	RB Allocation	Ch	Freq (MHz)	RB Allocation				
LTE 66B	Main 5	QPSK / 10MHz	21001	2525.1	1RB High	21199	2544.9	1RB Low	Top Edge	0.55	0.13	0.14
	Aux 8	QPSK / 10MHz	21001	2525.1	1RB High	21199	2544.9	1RB Low	Top Edge	0.75	0.09	0.11
LTE 66C	Main 5	QPSK / 20MHz	21001	2525.1	1RB High	21199	2544.9	1RB Low	Top Edge	0.41	0.86	0.94
	Aux 8	QPSK / 20MHz	21001	2525.1	1RB High	21199	2544.9	1RB Low	Top Edge	0.64	0.62	0.72

PCC RB allocation settings for UL CA has been adjusted based on the worst-case power

LTE Band 66 for UL CA 66A Inter-band and ENDC

Band	Ant	BW (MHz)	Mod.	Channel Number	Freq (MHz)	Position	% RB Allocation	Scaling Factor (dB)	Measured SAR 1g (W/Kg)	Reported SAR 1g (W/Kg)
Band 66A	Aux 8	20	QPSK	132322	1745	Top edge	1RB Mid	0.40	0.38	0.42

B.4.3 5G NR

B.4.3.1 5G NR 2

Band	Antenna	Modulation / BW	Channel Number	Freq (MHz)	Position	% RB Allocation	Scaling Factor (dB)	Measured SAR 1g (W/Kg)	Reported SAR 1g (W/Kg)	Plot #
NR2	Aux 8	QPSK / 20MHz	372000	1860.0	Top edge	1RB Low	0.03	0.79	0.80	
						50RB Low	0.00	0.77	0.77	
			376000	1880.0	Back Face	1RB Mid	0.91	0.35	0.44	
						50RB Mid	0.91	0.36	0.45	
			380000	1900.0	Top edge	1RB Mid	0.91	0.85	1.04	15
						50RB Mid	0.91	0.78	0.96	
						100RB Low	0.96	0.77	0.96	
			380000	1900.0	Top edge	1RB High	0.00	0.84	0.84	
						50RB High	0.00	0.81	0.81	

B.4.3.2 5G NR 5

Band	Antenna	Modulation / BW	Channel Number	Freq (MHz)	Position	% RB Allocation	Scaling Factor (dB)	Measured SAR 1g (W/Kg)	Reported SAR 1g (W/Kg)	Plot #
NR5	Main 5	QPSK / 20MHz	167300	836.5	Back Face	1RB Mid	1.03	0.27	0.34	
						50RB Mid	0.99	0.27	0.34	
					Right edge	1RB Mid	1.03	0.11	0.14	
						50RB Mid	0.99	0.12	0.14	
					Top edge	1RB Mid	1.03	0.89	1.13	16
						50RB Mid	0.99	0.88	1.11	
						100RB Low	1.03	0.86	1.09	

B.4.3.3 5G NR 7

Band	Antenna	Modulation / BW	Channel Number	Freq (MHz)	Position	% RB Allocation	Scaling Factor (dB)	Measured SAR 1g (W/Kg)	Reported SAR 1g (W/Kg)	Plot #
NR7	Main 5	QPSK / 20MHz	502000	2510.0	Top edge	1RB Mid	0.00	1.26	1.26	
						50RB Mid	0.00	1.27	1.27	
			507000	2535.0	Back Face	1RB Mid	0.00	0.26	0.26	
						50RB Mid	0.00	0.26	0.26	
					Right edge	1RB Mid	0.00	0.09	0.09	
						50RB Mid	0.00	0.09	0.09	
			512000	2560.0	Top edge	1RB Mid	0.00	1.29	1.29	
						50RB Mid	0.00	1.28	1.28	
						100RB Low	0.00	1.32	1.32	17
			512000	2560.0	Top edge	1RB Mid	0.00	1.32	1.32	
						50RB Mid	0.00	1.32	1.32	
						100RB Low	0.00	1.26	1.26	

B.4.3.4 5G NR 25

Band	Antenna	Modulation / BW	Channel Number	Freq (MHz)	Position	% RB Allocation	Scaling Factor (dB)	Measured SAR 1g (W/Kg)	Reported SAR 1g (W/Kg)	Plot #
NR25	Main 5	QPSK / 20MHz	372000	1860.0	Top edge	1RB Low	0.04	0.99	1.00	
						50RB Low	0.00	0.97	0.97	
			376500	1882.5	Back Face	1RB Mid	0.71	0.33	0.39	
						50RB Mid	0.68	0.33	0.39	
					Right edge	1RB Mid	0.71	0.05	0.06	
						50RB Mid	0.68	0.05	0.06	
					Top edge	1RB Mid	0.71	1.01	1.19	18
						50RB Mid	0.68	0.98	1.15	
			100RB Low	0.83	0.97	1.17				
			381000	1905.0	Top edge	1RB High	0.00	1.06	1.06	
50RB High	0.00	1.00				1.00				

B.4.3.5 5G NR 30

Band	Antenna	Modulation / BW	Channel Number	Freq (MHz)	Position	% RB Allocation	Scaling Factor (dB)	Measured SAR 1g (W/Kg)	Reported SAR 1g (W/Kg)	Plot #
NR 30	Main 5	QPSK / 10MHz	462000	2310.0	Back Face	1RB Mid	0.84	0.32	0.39	
						50RB Mid	0.87	0.32	0.39	
					Right edge	1RB Mid	0.84	0.04	0.05	
						50RB Mid	0.87	0.04	0.05	
					Top edge	1RB Mid	0.84	0.83	1.01	19
						50RB Mid	0.87	0.81	0.99	
						100RB Low	0.91	0.79	0.97	

B.4.3.6 5G NR 38

Band	Antenna	Modulation / BW	Channel Number	Freq (MHz)	Position	% RB Allocation	Scaling Factor (dB)	Measured SAR 1g (W/Kg)	Reported SAR 1g (W/Kg)	Plot #
NR 38	Aux 8	QPSK / 10MHz	519000	2595.0	Top edge	1RB Mid	0.28	1.06	1.13	20
						50RB Mid	0.22	1.04	1.09	
						100RB Low	0.16	1.06	1.10	

B.4.3.9 5G NR 77

Band	Antenna	Modulation / BW	Channel Number	Freq (MHz)	Position	% RB Allocation	Scaling Factor (dB)	Measured SAR 1g (W/Kg)	Reported SAR 1g (W/Kg)	Plot #
NR77	Main 5	QPSK / 100MHz	650000	3750.0	Back Face	1RB Mid	0.60	0.05	0.06	
						50RB Mid	0.26	0.06	0.06	
					Right edge	1RB Mid	0.60	0.08	0.09	
						50RB Mid	0.26	0.09	0.09	
	Top edge	1RB Mid	0.60	0.26	0.30					
		50RB Mid	0.26	0.28	0.30					
	Aux 8	QPSK / 100MHz	650000	3750.0	Back Face	1RB Mid	1.33	0.04	0.06	
						50RB Mid	0.96	0.03	0.04	
Top edge					1RB Mid	1.33	0.23	0.32	23	
					50RB Mid	0.96	0.24	0.30		

B.4.3.10 5G NR 78

Band	Antenna	Modulation / BW	Channel Number	Freq (MHz)	Position	% RB Allocation	Scaling Factor (dB)	Measured SAR 1g (W/Kg)	Reported SAR 1g (W/Kg)	Plot #
NR78	Aux 8	QPSK / 100MHz	650000	3750.0	Back Face	1RB Mid	0.98	0.36	0.45	
						50RB Mid	0.93	0.37	0.46	
					Top edge	1RB Mid	0.98	0.38	0.47	24
						50RB Mid	0.93	0.37	0.46	

B.4.4 SAR Measurement Variability

According to FCC OET KDB 865664, SAR Measurement variability is assessed when the maximum initial measured SAR is ≥ 0.8 W/kg for a certain band/mode. If the measured SAR value of the initial repeated measurement is < 1.45 W/kg with $< 20\%$ variation, only one repeated measurement is required to confirm that the results are not expected to have substantial variations.

A second repeated measurement is required only if the measured results for the initial repeated measurement are within 10% of the SAR limit or vary by more than 20%.

A third repeated measurement is required only if the original, first or second repeated measurement ≥ 1.5 W/Kg and the ratio of largest to smallest SAR for the original, first and second repeated measurement is > 1.2 .

Band / Mode	Position	Ch #	Freq. (MHz)	Measured SAR 1g (W/kg)	1 st Repeated SAR 1g (W/Kg)	2 nd Repeated SAR 1g (W/Kg)	Highest Ratio
LTE FDD 13 / QPSK - 10MHz	Top edge	23230	782.0	1.00	0.99		1.01
LTE FDD 5 / QPSK - 10MHz	Top edge	20525	836.5	0.92	0.87		1.05
WCDMA FDD IV - 5MHz	Top edge	1313	1712.4	0.90	0.89		1.01
LTE FDD 25 / QPSK - 20MHz	Top edge	19150	1905.0	0.89	0.88		1.01
LTE FDD 7 / QPSK - 20MHz	Top edge	27710	2310.0	1.18	1.16		1.02
LTE FDD 30 / QPSK - 10MHz	Top edge	21100	2535.0	1.32	1.16		1.12

B.4.5 Simultaneous Transmission SAR Evaluation

According to FCC OET KDB 447498 D01, when the sum of 1g SAR for all simultaneously transmitting antennas in an operating mode and exposure condition combination is within the SAR limit, SAR test exclusion applies to that simultaneous transmission configuration.

As commented on section 3 and 6, this report only evaluates SAR for cellular transmission on the module, nevertheless in order to consider all possible simultaneous transmissions on the device for compliance, WLAN SAR values reported on document [1] are considered.

[1] 210916-04.TR01 - HSN-I46C wAX211NGW WLAN_WWAN – Legacy

[2] 210916-04.TR02 - HSN-I46C wAX211NGW WLAN_WWAN – WiFi 6E

All the values stated in the table below are the worst case found for standalone measurement with disregard of the transmission mode or channel where the worst case was found

Antenna	Position	Highest Reported SAR (1g) (W/Kg)								
		WWAN			WLAN 2.4GHz		WLAN 5/6GHz	Bluetooth		
		Standalone ¹	LTE ULCA ²	ENDC ³						
WWAN (Main 5)	Top Edge	1.41	0.44	1.30						
	Back Face	0.39								
	Right Edge	0.42								
	Left Edge	0.40 ⁶								
WWAN (Aux 8)	Top Edge	1.13	0.42							
	Back Face	0.57								
	Right Edge	0.40 ⁶								
	Left Edge	0.40 ⁶								
Main WLAN	Top Edge			1.17 ⁴				0.56 ⁵	0.64	
	Back Face			0.05				0.19		
	Right Edge			0.40 ⁶		0.40 ⁶				
	Left Edge			0.16		0.19				
Aux WLAN	Top Edge			1.13 ⁴	0.52 ⁵	0.92	0.22			
	Back Face			0.12		0.15	0.04			
	Right Edge			0.40 ⁶		0.40 ⁶	0.40 ⁶			
	Left Edge			0.40 ⁶		0.40 ⁶	0.40 ⁶			

1. Standalone WWAN transmission
2. Standalone reduced 3dBm ULCA inter-band.
3. 5G ENDC mode.
4. WLAN SISO mode
5. WLAN MIMO mode
6. According to FCC OET KDB 447498 D01, when standalone test exclusion is applied to an antenna that transmits simultaneously with other antennas, the standalone SAR must be estimated to 0.4 W/Kg for 1-g SAR when the test separation is > 50mm in order to determine simultaneous transmission test exclusion.

Position	Simultaneous Tx Antenna Combination				Σ SAR 1g (W/Kg)	Limit (W/kg)	
	#	WWAN Main 5	WWAN Aux 8	Main Antenna			Aux Antenna
Top Edge	1	Cellular	Cellular	WLAN 5/6GHz	WLAN 5/6GHz	3.70	1.6
	2	Cellular	Cellular	WLAN 5/6GHz	WLAN 5/6GHz+ BT	3.92	
	3	Cellular	Cellular	WLAN 5/6GHz	BT	3.40	
	4	Cellular	Cellular	WLAN 2.4GHz	WLAN 2.4GHz	4.84	
	5	Cellular	Cellular	WLAN 2.4GHz	BT	3.93	
Back Face	1	Cellular	Cellular	WLAN 5/6GHz	WLAN 5/6GHz	1.34	
	2	Cellular	Cellular	WLAN 5/6GHz	WLAN 5GHz+ BT	1.38	
	3	Cellular	Cellular	WLAN 5/6GHz	BT	1.19	
	4	Cellular	Cellular	WLAN 2.4GHz	WLAN 2.4GHz	1.13	
	5	Cellular	Cellular	WLAN 2.4GHz	BT	1.05	
Right Edge	1	Cellular	Cellular	WLAN 5/6GHz	WLAN 5/6GHz	1.62	
	2	Cellular	Cellular	WLAN 5/6GHz	WLAN 5/6GHz+ BT	2.02	
	3	Cellular	Cellular	WLAN 5/6GHz	BT	1.62	
	4	Cellular	Cellular	WLAN 2.4GHz	WLAN 2.4GHz	1.62	
	5	Cellular	Cellular	WLAN 2.4GHz	BT	1.62	
Left Edge	1	Cellular	Cellular	WLAN 5/6GHz	WLAN 5/6GHz	1.39	
	2	Cellular	Cellular	WLAN 5/6GHz	WLAN 5/6GHz+ BT	1.70	
	3	Cellular	Cellular	WLAN 5/6GHz	BT	1.30	
	4	Cellular	Cellular	WLAN 2.4GHz	WLAN 2.4GHz	1.36	
	5	Cellular	Cellular	WLAN 2.4GHz	BT	1.36	

In case the sum of SAR is larger than the limit, SAR test exclusion is determined by the SAR to peak location separation ratio. According to the last table possible simultaneous transmission combinations are identified for each position from 1 to 5, each combination will be analyzed by antenna pairs. Antenna pairs considered in one configuration won't be performed again in case they are repeated on the next simultaneous configuration:

Position	Ant. Pair case	Antenna	Reported SAR 1g (W/kg)	Σ SAR 1g (W/Kg)	Peak Location (mm) (x,y,z)	SAR to peak location separation ratio	Limit	
Top Edge	1a	WWAN (Main 5)	1.41	1.95	(1.9 ; 115.2 ; -172.3)	0.03	0.04	
		WWAN (Aux 8)	0.54 ¹		(-2.3 ; 49.9 ; -171.4)			
		1b	WWAN (Main 5)	1.30 ²	1.73	(1.9 ; 115.2 ; -172.3)		0.03
			WWAN (Aux 8)	0.42 ²		(-2.3 ; 49.9 ; -171.4)		
	1c	WWAN (Main 5)	1.41	1.88	(1.9 ; 115.2 ; -172.3)	0.02		
		Main WLAN 5/6GHz	0.47		(-1.7; -52.2; -177.1)			
	1d	WWAN (Main 5)	1.41	2.07	(1.9 ; 115.2 ; -172.3)	0.02		
		Aux WLAN 5/6GHz	0.66		(0; -34; -177.1)			
	1e	WWAN (Aux 8)	1.13	1.57				
		Main WLAN 5/6GHz	0.47					
	1f	WWAN (Aux 8)	1.10	1.77	(-2.3 ; 49.9 ; -171.4)	0.03		
		Aux WLAN 5/6GHz	0.66		(0; -34; -177.1)			
	2a	Main WLAN 5/6GHz	0.47	1.13				
		Aux WLAN 5/6GHz	0.66					
	2b	WWAN (Main 5)	1.41	1.63	(1.9 ; 115.2 ; -172.3)	0.01		
		Aux WLAN1 BT	0.22		(0,-24.5, -177.1)			
	2c	WWAN (Aux 8)	1.13	1.32				
		Aux WLAN1 BT	0.22					
	4a	WWAN (Main 5)	1.41	2.58	(1.9 ; 115.2 ; -172.3)	0.01		
		Main WLAN 2.4GHz	1.17		(8.5,-74.5, -177.1)			
4b	WWAN (Main 5)	1.41	2.54	(1.9 ; 115.2 ; -172.3)	0.03			
	AuxWLAN 2.4GHz	1.13		(7.5; -24; -173.5)				
4c	WWAN (Aux 8)	1.10	2.27	(-2.3 ; 49.9 ; -171.4)	0.03			
	Main WLAN 2.4GHz	1.17		(8.5,-74.5, -177.1)				
4d	WWAN (Aux 8)	1.13	2.23	(-2.3 ; 49.9 ; -171.4)	0.04			
	AuxWLAN 2.4GHz	1.13		(7.5; -24; -173.5)				
4e	Main WLAN 2.4GHz	0.56 ³	1.08					
	AuxWLAN1 2.4GHz	0.52 ³						

1. Standalone reduced 3dBm ULCA interband
2. 5G ENDC mode.
3. WLAN MIMO mode

Position	Ant. Pair case	Antenna	Reported SAR 1g (W/kg)	Σ SAR 1g (W/Kg)	Peak Location (mm) (x,y,z)	SAR to peak location separation ratio	Limit
Right Edge	1a	WWAN (Main 5)	0.42	0.82			0.04
		WWAN (Aux 8)	0.40				
	1b	WWAN (Main 5)	0.42	0.80			
		Main WLAN 5/6GHz	0.40				
	1c	WWAN (Main 5)	0.42	0.82			
		Aux WLAN 5/6GHz	0.40				
	1d	WWAN (Aux 8)	0.40	0.80			
		Main WLAN 5/6GHz	0.40				
	1e	WWAN (Aux 8)	0.40	0.80			
		Aux WLAN 5/6GHz	0.40				
	1f	Main WLAN 5GHz	0.40	0.80			
		Aux WLAN 5GHz	0.40				
	2a	WWAN (Main 5)	0.42	0.82			
		Aux WLAN1 BT	0.40				
	2b	WWAN (Aux 8)	0.40	0.80			
		Aux WLAN1 BT	0.40				
	4a	WWAN (Main 5)	0.42	0.82			
		Main WLAN 2.4GHz	0.40				
	4b	WWAN (Main 5)	0.42	0.82			
		Aux WLAN 2.4GHz	0.40				
4c	WWAN (Aux 8)	0.40	0.80				
	Main WLAN 2.4GHz	0.40					
4d	WWAN (Aux 8)	0.40	0.80				
	Aux WLAN 2.4GHz	0.40					
4e	Main WLAN 2.4GHz	0.40	0.80				
	Aux WLAN1 2.4GHz	0.40					

Position	Ant. Pair case	Antenna	Reported SAR 1g (W/kg)	Σ SAR 1g (W/Kg)	Peak Location (mm) (x,y,z)	SAR to peak location separation ratio	Limit
Left Edge	1a	WWAN (Main 5)	0.40	0.80			0.04
		WWAN (Aux 8)	0.40				
	1b	WWAN (Main 5)	0.40	0.59			
		Main WLAN 5/6GHz	0.19				
	1c	WWAN (Main 5)	0.40	0.80			
		Aux WLAN 5/6GHz	0.40				
	1d	WWAN (Aux 8)	0.40	0.59			
		Main WLAN 5GHz	0.19				
	1e	WWAN (Aux 8)	0.40	0.80			
		Aux WLAN 5/6GHz	0.40				
	1f	Main WLAN 5GHz	0.19	0.59			
		Aux WLAN 5GHz	0.40				
	2a	WWAN (Main 5)	0.40	0.80			
		Aux WLAN1 BT	0.40				
	2b	WWAN (Aux 8)	0.40	0.80			
		Aux WLAN1 BT	0.40				
	4a	WWAN (Main 5)	0.40	0.56			
		Main WLAN 2.4GHz	0.16				
	4b	WWAN (Main 5)	0.40	0.80			
		Aux WLAN 2.4GHz	0.40				
4c	WWAN (Aux 8)	0.40	0.56				
	Main WLAN 2.4GHz	0.16					
4d	WWAN (Aux 8)	0.40	0.80				
	Aux WLAN 2.4GHz	0.40					
4e	Main WLAN 2.4GHz	0.16	0.56				
	Aux WLAN1 2.4GHz	0.40					

Annex C. Test System Plots

1. WCDMA FDD II, 12.2kbps RMC, CH9538, Top Edge.....	106
2. WCDMA FDD IV, 12.2kbps RMC, CH1312, Top Edge	107
3. WCDMA FDD V, 12.2kbps RMC, CH4132, Top edge.....	108
4. LTE Band 5, QPSK - 10MHz, CH20525, Top Edge	109
5. LTE Band 7, QPSK - 20MHz, CH20850, Top Edge	110
6. LTE Band 12, QPSK - 10MHz, CH23095, Top Edge	111
7. LTE Band 13, QPSK - 10MHz, CH23230, Top edge.....	112
8. LTE Band 14, QPSK - 10MHz, CH23330, Top edge.....	113
9. LTE Band 25, QPSK - 20MHz, CH26365, Top Edge	114
10. LTE Band 26, QPSK - 15MHz, CH26865, Top Edge.....	115
11. LTE Band 30, QPSK - 10MHz, CH27710, Top Edge.....	116
12. LTE Band 41, QPSK - 20MHz, CH40620, Top Edge.....	117
13. LTE Band 48, QPSK - 20MHz, CH55990, Top Edge.....	118
14. LTE Band 66, QPSK - 20MHz, CH132572, Top Edge.....	119
15. 5G NR FR1 Band 2, QPSK - 20MHz, CH376000 – Top Edge.....	120
16. 5G NR FR1 Band 5, QPSK - 20MHz, CH167300 – Top Edge.....	121
17. 5G NR FR1 Band 7, QPSK - 20MHz, CH507000 – Top Edge.....	122
18. 5G NR FR1 Band 25, QPSK - 20MHz, CH381000 – Top Edge.....	123
19. 5G NR FR1 Band 30, QPSK - 10MHz, CH462000 – Top Edge.....	124
20. 5G NR FR1 Band 38, QPSK - 10MHz, CH519000 – Top Edge.....	125
21. 5G NR FR1 Band 41, QPSK - 100MHz, CH518598 – Top Edge.....	126
22. 5G NR FR1 Band 66, QPSK - 40MHz, CH349000 – Top Edge.....	127
23. 5G NR FR1 Band 77, QPSK - 100MHz, CH650000 – Top Edge.....	128
24. 5G NR FR1 Band 78, QPSK - 100MHz, CH650000 – Top Edge.....	129
25. System Check Body Liquid 750MHz	130
26. System Check Body Liquid 835MHz - 2021-11-23.....	131
27. System Check Body Liquid 835MHz - 2021-11-17.....	132
28. System Check Body Liquid 1750MHz – 2021-11-25.....	133
29. System Check Body Liquid 1750MHz – 2021-11-24.....	134
30. System Check Body Liquid 1750MHz – 2021-11-17.....	135
31. System Check Body Liquid 1900MHz - 2021-11-24.....	136
32. System Check Body Liquid 1900MHz - 2021-11-25.....	137
33. System Check Body Liquid 1900MHz - 2021-11-16.....	138
34. System Check Body Liquid 2300MHz - 2021-11-30.....	139
35. System Check Body Liquid 2300MHz - 2021-11-17.....	140
36. System Check Body Liquid 2600MHz – 2021-11-22.....	141
37. System Check Body Liquid 2600MHz – 2021-11-23.....	142
38. System Check Body Liquid 2600MHz – 2021-11-17.....	143
39. System Check Body Liquid 2600MHz – 2021-11-16.....	144

40.	System Check Body Liquid 2600MHz – 2021-12-03	145
41.	System Check Body Liquid 3700MHz	146

1. WCDMA FDD II, 12.2kbps RMC, CH9538, Top Edge

Device under Test Properties

Name, Manufacturer	Dimensions [mm]	S/N	DUT Type
HSN-I46C	225.0 x 315.0 x 17.0	00017609DK	Convertible PC

Exposure Conditions

Phantom Section, TSL	Position, Test Distance [mm]	Band	Group, UID	Frequency [MHz], Channel Number	Conversion Factor	TSL Conductivity [S/m]	TSL Permittivity
Flat, MSL	EDGE TOP, 0.00	Band 2, UTRA/FDD	WCDMA, 10011-CAB	1907.6, 9538	7.97	1.51	51.0

Hardware Setup

Phantom	TSL, Measured Date	Probe, Calibration Date	DAE, Calibration Date
ELI V8.0 (20deg probe tilt)	MBBL-600-6000, 2021-Nov-25	EX3DV4 - SN3978, 2021-05-21	DAE4 Sn1429, 2021-05-11

Scan Setup

	Area Scan	Zoom Scan
Grid Extents [mm]	60.0 x 330.0	30.0 x 30.0 x 30.0
Grid Steps [mm]	15.0 x 15.0	4.9 x 4.9 x 1.4
Sensor Surface [mm]	3.0	1.4
Graded Grid	Yes	Yes
Grading Ratio	1.5	1.4
MAIA	Confirmed by MAIA	Confirmed by MAIA
Surface Detection	VMS + 6p	VMS + 6p
Scan Method	Measured	Measured

Measurement Results

	Area Scan	Zoom Scan
Date	2021-11-25, 14:15	2021-11-25, 14:25
psSAR1g [W/kg]	0.808	0.842
psSAR10g[W/kg]	0.366	0.345
Power Drift [dB]	0.03	0.05
Power Scaling	Disabled	Disabled
Scaling Factor		
TSL Correction [dB]	Positive Only	Positive Only
M2/M1 [%]		73.6
Dist3dBPeak[mm]		5.9

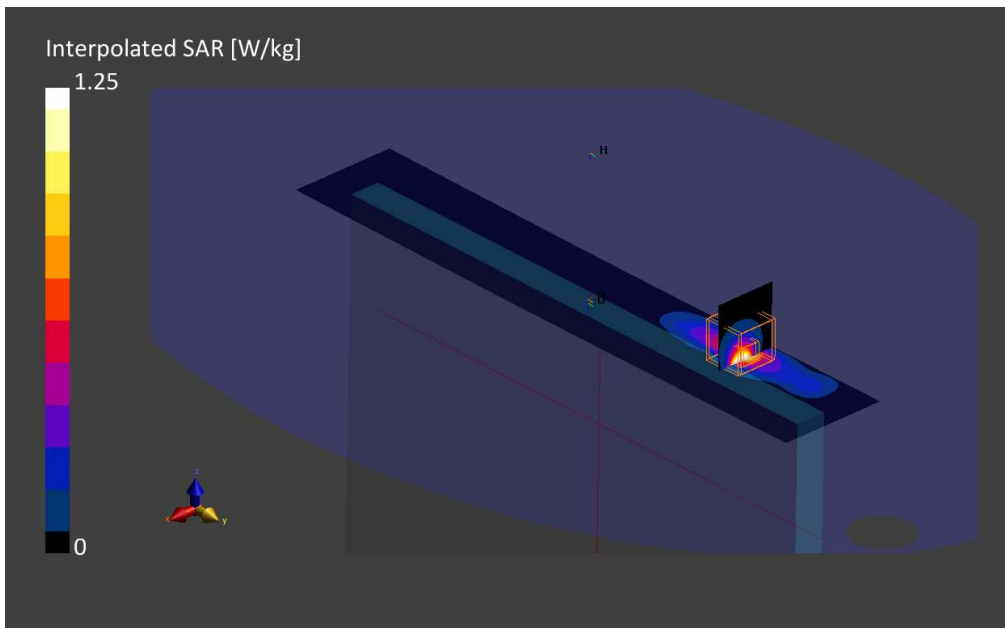

2. WCDMA FDD IV, 12.2kbps RMC, CH1312, Top Edge

Device under Test Properties

Name, Manufacturer	Dimensions [mm]	S/N	DUT Type
HSN-I46C	225.0 x 315.0 x 17.0	00017609DK	Convertible PC

Exposure Conditions

Phantom Section, TSL	Position, Test Distance [mm]	Band	Group, UID	Frequency [MHz], Channel Number	Conversion Factor	TSL Conductivity [S/m]	TSL Permittivity
Flat, MSL	EDGE TOP, 0.00	Band 4, UTRA/FDD	WCDMA, 10011-CAB	1712.4, 1312	8.26	1.38	51.3

Hardware Setup

Phantom	TSL, Measured Date	Probe, Calibration Date	DAE, Calibration Date
ELI V8.0 (20deg probe tilt)	MABL-600-6000, 2021-Nov-25	EX3DV4 - SN3978, 2021-05-21	DAE4 Sn1429, 2021-05-11

Scan Setup

	Area Scan	Zoom Scan
Grid Extents [mm]	60.0 x 330.0	30.0 x 30.0 x 30.0
Grid Steps [mm]	15.0 x 15.0	5.4 x 5.4 x 1.5
Sensor Surface [mm]	3.0	1.4
Graded Grid	Yes	Yes
Grading Ratio	1.5	1.5
MAIA	Confirmed by MAIA	Confirmed by MAIA
Surface Detection	VMS + 6p	VMS + 6p
Scan Method	Measured	Measured

Measurement Results

	Area Scan	Zoom Scan
Date	2021-11-25, 12:37	2021-11-25, 12:44
psSAR1g [W/kg]	0.873	0.894
psSAR10g [W/kg]	0.439	0.389
Power Drift [dB]	0.05	0.14
Power Scaling	Disabled	Disabled
Scaling Factor [dB]		
TSL Correction	Positive Only	Positive Only
M2/M1 [%]		71.4
Dist3dBPeak[mm]		5.4

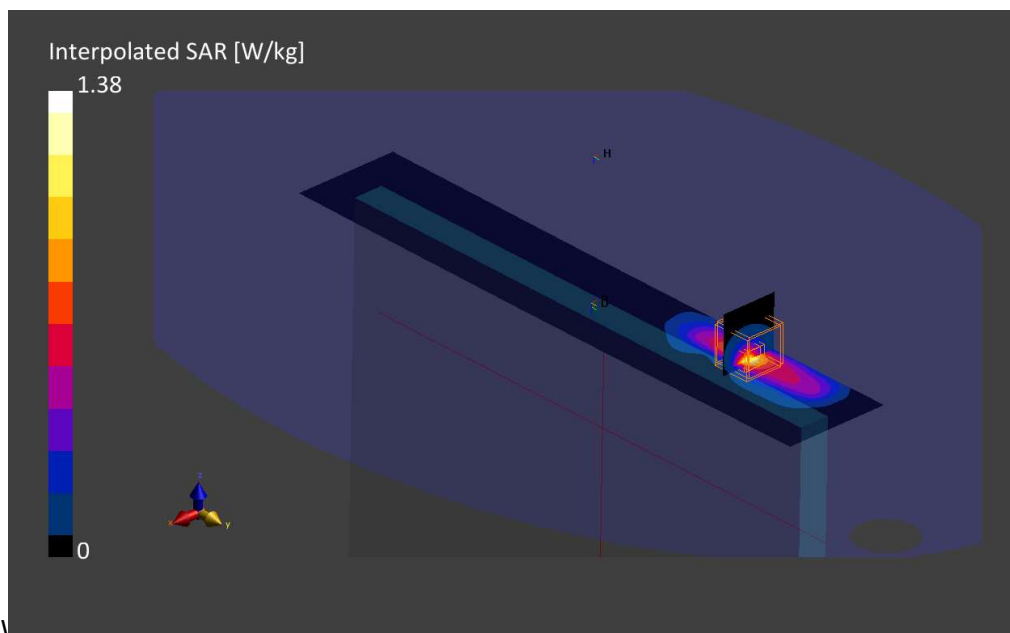

3. WCDMA FDD V, 12.2kbps RMC, CH4132, Top edge

Device under Test Properties

Name, Manufacturer	Dimensions [mm]	S/N	DUT Type
HSN-I46C	225.0 x 315.0 x 17.0	00017609DK	Convertible PC

Exposure Conditions

Phantom Section, TSL	Position, Test Distance [mm]	Band	Group, UID	Frequency [MHz], Channel Number	Conversion Factor	TSL Conductivity [S/m]	TSL Permittivity
Flat, MSL	EDGE TOP, 0.00	Band 5, UTRA/FDD	WCDMA, 10011-CAB	826.4, 4132	9.79	0.97	53.3

Hardware Setup

Phantom	TSL, Measured Date	Probe, Calibration Date	DAE, Calibration Date
ELI V8.0 (20deg probe tilt)	MABL-600-6000, 2021-Nov-22	EX3DV4 - SN3978, 2021-05-21	DAE4 Sn1429, 2021-05-11

Scan Setup

	Area Scan	Zoom Scan
Grid Extents [mm]	60.0 x 330.0	30.0 x 30.0 x 30.0
Grid Steps [mm]	15.0 x 15.0	4.9 x 4.9 x 1.4
Sensor Surface [mm]	3.0	1.4
Graded Grid	Yes	Yes
Grading Ratio	1.5	1.4
MAIA	Confirmed by MAIA	Confirmed by MAIA
Surface Detection	VMS + 6p	VMS + 6p
Scan Method	Measured	Measured

Measurement Results

	Area Scan	Zoom Scan
Date	2021-11-23, 19:28	2021-11-23, 19:38
psSAR1g [W/kg]	0.638	0.859
psSAR10g[W/kg]	0.397	0.419
Power Drift [dB]	0.03	-0.01
Power Scaling	Disabled	Disabled
Scaling Factor		
[dB]		
TSL Correction	Positive Only	Positive Only
M2/M1 [%]		68.2
Dist3dBPeak[mm]		5.9

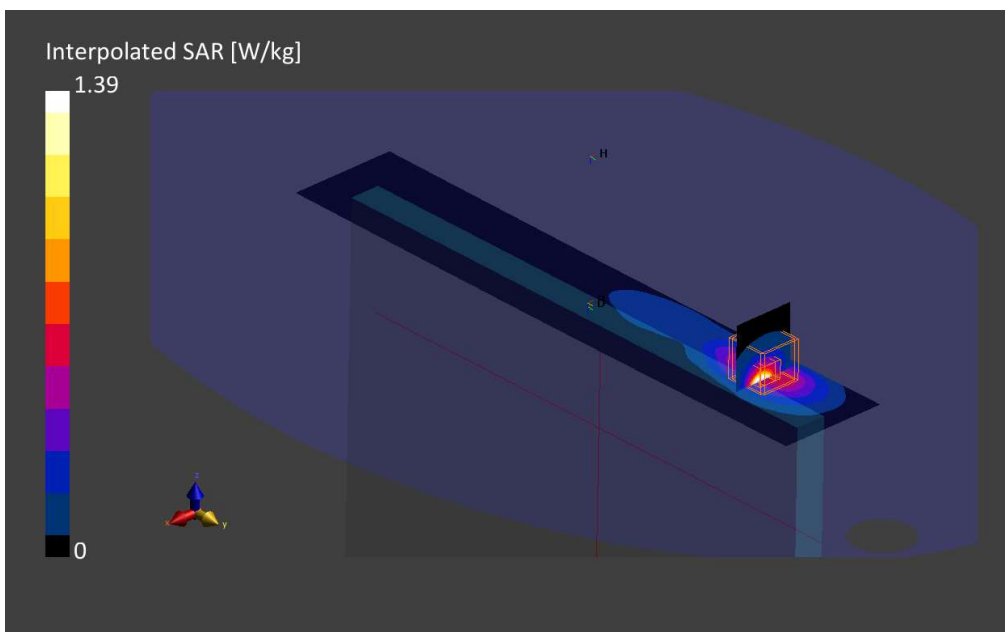

4. LTE Band 5, QPSK - 10MHz, CH20525, Top Edge

Device under Test Properties

Name, Manufacturer	Dimensions [mm]	S/N	DUT Type
HSN-I46C	225.0 x 315.0 x 17.0	00017609DK	Convertible PC

Exposure Conditions

Phantom Section, TSL	Position, Test Distance [mm]	Band	Group, UID	Frequency [MHz], Channel Number	Conversion Factor	TSL Conductivity [S/m]	TSL Permittivity
Flat, MSL	EDGE TOP, 0.00	Band 5, E-UTRA/FDD	LTE-FDD, 10175-CAG	836.5, 20525	9.79	0.98	53.2

Hardware Setup

Phantom	TSL, Measured Date	Probe, Calibration Date	DAE, Calibration Date
ELI V8.0 (20deg probe tilt)	MBBL-600-6000 , 2021-Nov-22	EX3DV4 - SN3978, 2021-05-21	DAE4 Sn1429, 2021-05-11

Scan Setup

	Area Scan	Zoom Scan
Grid Extents [mm]	60.0 x 330.0	30.0 x 30.0 x 30.0
Grid Steps [mm]	15.0 x 15.0	4.9 x 4.9 x 1.4
Sensor Surface [mm]	3.0	1.4
Graded Grid	Yes	Yes
Grading Ratio	1.5	1.4
MAIA	Confirmed by MAIA	Confirmed by MAIA
Surface Detection	VMS + 6p	VMS + 6p
Scan Method	Measured	Measured

Measurement Results

	Area Scan	Zoom Scan
Date	2021-11-23, 16:38	2021-11-23, 16:47
psSAR1g [W/kg]	0.648	0.909
psSAR10g[W/kg]	0.414	0.443
Power Drift [dB]	0.00	0.04
Power Scaling	Disabled	Disabled
Scaling Factor		
TSL Correction [dB]	Positive Only	Positive Only
M2/M1 [%]		67.4
Dist3dBPeak[mm]		5.9

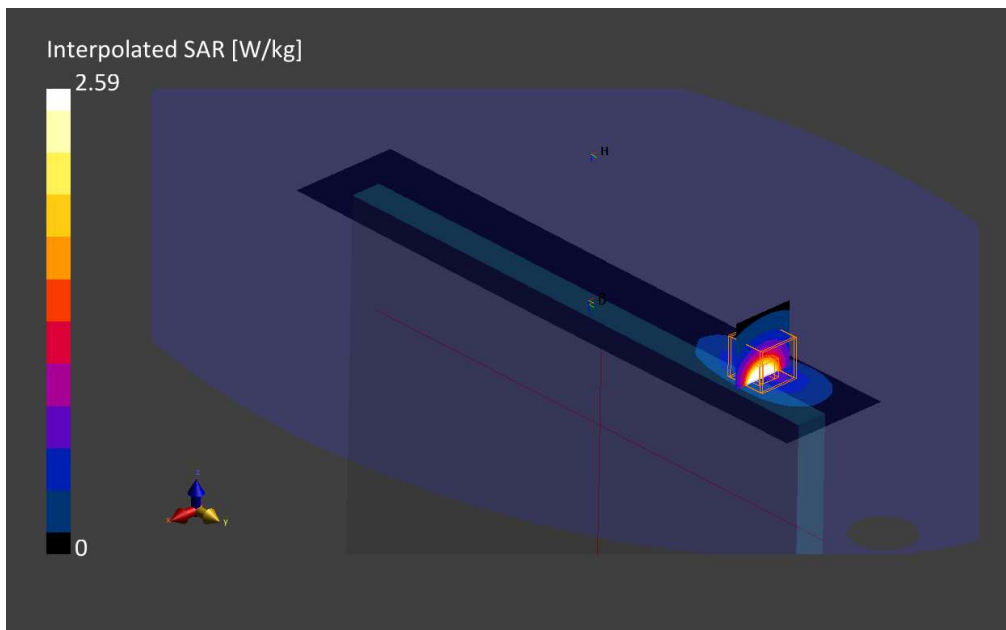

5. LTE Band 7, QPSK - 20MHz, CH20850, Top Edge

Device under Test Properties

Name, Manufacturer	Dimensions [mm]	S/N	DUT Type
HSN-I46C	225.0 x 315.0 x 17.0	00017609DK	Convertible PC

Exposure Conditions

Phantom Section, TSL	Position, Test Distance [mm]	Band	Group, UID	Frequency [MHz], Channel Number	Conversion Factor	TSL Conductivity [S/m]	TSL Permittivity
Flat, MSL	EDGE TOP, 0.00	Band 7, E-UTRA/FDD	LTE-FDD, 10169-CAE	2535.0, 21100	7.3	2.12	50.3

Hardware Setup

Phantom	TSL, Measured Date	Probe, Calibration Date	DAE, Calibration Date
ELI V8.0 (20deg probe tilt)	MBBL-600-6000, 2021-Nov-22	EX3DV4 - SN3978, 2021-05-21	DAE4 Sn1429, 2021-05-11

Scan Setup

	Area Scan	Zoom Scan
Grid Extents [mm]	60.0 x 340.0	30.0 x 30.0 x 30.0
Grid Steps [mm]	10.0 x 10.0	4.8 x 4.8 x 1.5
Sensor Surface [mm]	3.0	1.4
Graded Grid	Yes	Yes
Grading Ratio	1.5	1.5
MAIA	Confirmed by MAIA	Confirmed by MAIA
Surface Detection	VMS + 6p	VMS + 6p
Scan Method	Measured	Measured

Measurement Results

	Area Scan	Zoom Scan
Date	2021-11-22, 18:45	2021-11-22, 18:54
psSAR1g [W/kg]	1.37	1.32
psSAR10g[W/kg]	0.477	0.461
Power Drift [dB]	0.01	-0.01
Power Scaling	Disabled	Disabled
Scaling Factor		
TSL Correction [dB]	Positive Only	Positive Only
M2/M1 [%]		72.6
Dist3dBPeak[mm]		5.2

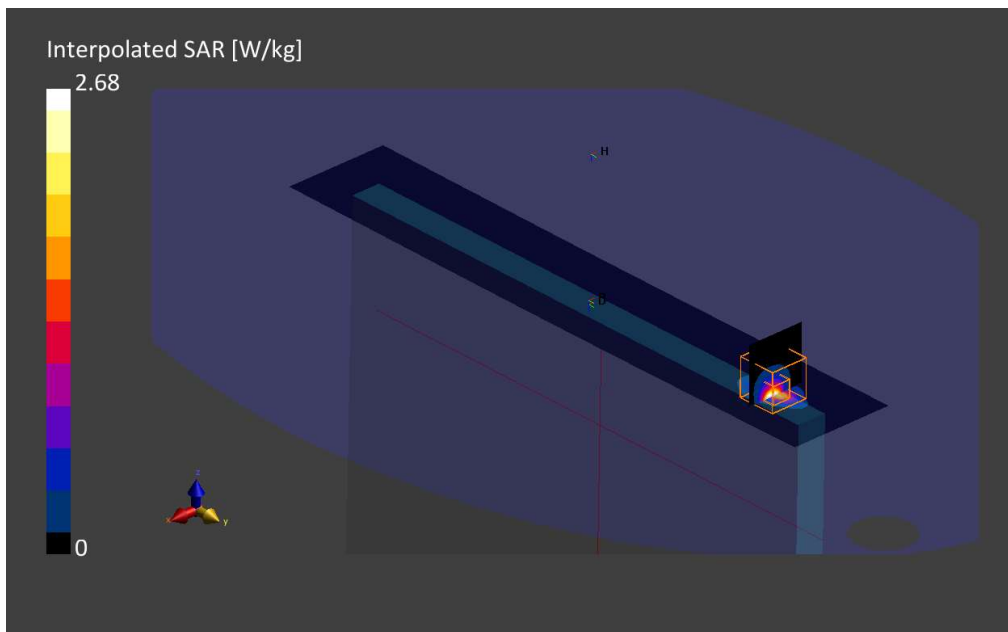

6. LTE Band 12, QPSK - 10MHz, CH23095, Top Edge

Device under Test Properties

Name, Manufacturer	Dimensions [mm]	S/N	DUT Type
HSN-I46C	225.0 x 315.0 x 17.0	00017609DK	Convertible PC

Exposure Conditions

Phantom Section, TSL	Position, Test Distance [mm]	Band	Group, UID	Frequency [MHz], Channel Number	Conversion Factor	TSL Conductivity [S/m]	TSL Permittivity
Flat, MSL	EDGE TOP, 0.00	Band 12, E-UTRA/FDD	LTE-FDD, 10175-CAG	707.5, 23095	10.05	0.93	53.6

Hardware Setup

Phantom	TSL, Measured Date	Probe, Calibration Date	DAE, Calibration Date
ELI V8.0 (20deg probe tilt)	MBBL-600-6000, 2021-Nov-22	EX3DV4 - SN3978, 2021-05-21	DAE4 Sn1429, 2021-05-11

Scan Setup

	Area Scan	Zoom Scan
Grid Extents [mm]	60.0 x 330.0	30.0 x 30.0 x 30.0
Grid Steps [mm]	15.0 x 15.0	6.0 x 6.0 x 1.5
Sensor Surface [mm]	3.0	1.4
Graded Grid	Yes	Yes
Grading Ratio	1.5	1.5
MAIA	Confirmed by MAIA	Confirmed by MAIA
Surface Detection	VMS + 6p	VMS + 6p
Scan Method	Measured	Measured

Measurement Results

	Area Scan	Zoom Scan
Date	2021-11-23, 09:07	2021-11-23, 09:13
psSAR1g [W/kg]	0.841	0.859
psSAR10g [W/kg]	0.496	0.441
Power Drift [dB]	0.01	-0.01
Power Scaling	Disabled	Disabled
Scaling Factor [dB]		
TSL Correction	Positive Only	Positive Only
M2/M1 [%]		75.1
Dist3dBPeak[mm]		8.4

