



TEST REPORT

TAS ALGORITHM COMPLIANCE

EUT Description	Wireless Module Installed in Notebook PC
Brand Name	HP
Model Name	HSN-I45C-3
FCC ID	B94HNI45C3KL
Date of Test Start/End	2023-10-05 / 2023-12-14
Features	LTE, NR

Applicant	HP Inc.
Address	1501 Page Mill Road, Palo Alto CA 94304 USA
Contact Person	Sam Lin
Telephone/Fax/ Email	+886 2 37896331/sam.lin2@hp.com

Test Report identification	230727-01.TR02
Revision Control	Rev. 01 This test report revision replaces any previous test report revision

The test results relate only to the samples tested.

Reviewed by _____

Adel LOUNES
(Test Lead Engineer)

Intel Corporation S.A.S – WRF Lab
425 rue de Goa – Le Cargo B6 - 06600, Antibes, France
Tel. +33493001400 / Fax +33493001401

TABLE OF CONTENTS

1. General conditions, competences and guarantees	3
2. Environmental Conditions	3
3. Test Samples	3
4. Software / Firmware	3
5. EUT Features	4
6. Remarks and comments	6
7. Document Revision History	6
Annex A. Test Setup Description	7
A.1 MEASUREMENT SYSTEM.....	7
A.2 TEST EQUIPMENT LIST	8
Annex B. Test Results	9
B.1 SUMMARY OF TEST CASES	9
B.2 BANDS VALIDATION - NR	10
B.3 BANDS VALIDATION - LTE.....	12

1. General conditions, competences and guarantees

- ✓ Intel WRF Lab only provides testing services and is committed to providing reliable, unbiased test results and interpretations.
- ✓ Intel WRF Lab is liable to the client for the maintenance of the confidentiality of all information related to the item under test and the results of the test.
- ✓ Intel WRF Lab has developed calibration and proficiency programs for its measurement equipment to ensure correlated and reliable results to its customers.
- ✓ This report is only referred to the item that has undergone the test.
- ✓ This report does not imply an approval of the product by the Certification Bodies or competent Authorities.

2. Environmental Conditions

- ✓ At the site where the measurements were performed the following limits were not exceeded during the tests:

Temperature	22.9°C ± 0.7°C
Humidity	34.9% ± 4.5%

3. Test Samples

Sample	ID	Description	Model	Serial	Module Serial
#1	210825-01.S04	Notebook PC with FM350-GL Module Embedded	HSN-I45C-3	0001760B1N	C202MN1BG9

4. Software / Firmware

Sample #1

Firmware	Version
Fibocom	81600.0000.00.29.23.03 V1.0.6

5. EUT Features

The herein information is provided by the customer.

Intel WRF Lab declines any responsibility for the accuracy of the stated customer provided information, especially if it has any impact on the correctness of test results presented in this report.

Brand Name	HP
Model Name	HSN-I45C-3
Prototype / Production	Production
Host Identification	HSN-I45C-3

Supported radios

WWAN: The module is a data only DUT. The applicable frequency bands and operating modes are identified in the following table.

Mode	Bands	Supported Tx Mode			
		RMC	HSDPA	HSUPA	DC-HSDPA
WCDMA / HSPA+	FDD II (1850.0 – 1910.0 MHz)	✓	✓	✓	✓
	FDD IV (1710.0 – 1755.0 MHz)	✓	✓	✓	✓
	FDD V (824.0 – 849.0 MHz)	✓	✓	✓	✓

FDD/TDD	Bands	Modulations	Bandwidth					
			1.4	3	5	10	15	20
LTE FDD	Band 2 (1850.0 – 1910.0 MHz)	QPSK/16QAM/64QAM/256QAM	✓	✓	✓	✓	✓	✓
	Band 4 (1710.0 – 1755.0 MHz)	QPSK/16QAM/64QAM/256QAM	✓	✓	✓	✓	✓	✓
	Band 5 (824.0 – 849.0 MHz)	QPSK/16QAM/64QAM/256QAM	✓	✓	✓	✓		
	Band 7 (2500.0 – 2570.0 MHz)	QPSK/16QAM/64QAM/256QAM			✓	✓	✓	✓
	Band 12 (699.0 – 716.0 MHz)	QPSK/16QAM/64QAM/256QAM	✓	✓	✓	✓		
	Band 13 (777.0 – 787.0 MHz)	QPSK/16QAM/64QAM/256QAM			✓	✓		
	Band 14 (788.0 – 798.0 MHz)	QPSK/16QAM/64QAM/256QAM			✓	✓		
	Band 17 (704.0 – 716.0 MHz)	QPSK/16QAM/64QAM/256QAM			✓	✓		
	Band 25 (1850.0 – 1915.0 MHz)	QPSK/16QAM/64QAM/256QAM	✓	✓	✓	✓	✓	✓
	Band 26 (814.0 – 849.0 MHz)	QPSK/16QAM/64QAM/256QAM	✓	✓	✓	✓	✓	
	Band 30 (2305.0 – 2315.0 MHz)	QPSK/16QAM/64QAM/256QAM			✓	✓		
	Band 66 (1710.0 – 1780.0 MHz)	QPSK/16QAM/64QAM/256QAM	✓	✓	✓	✓	✓	✓
Band 71 (663.0 – 698.0 MHz)	QPSK/16QAM/64QAM/256QAM			✓	✓	✓	✓	
LTE TDD	Band 38 (2570.0 – 2620.0 MHz)	QPSK/16QAM/64QAM/256QAM			✓	✓	✓	✓
	Band 41 (2496.0 – 2690.0 MHz)	QPSK/16QAM/64QAM/256QAM			✓	✓	✓	✓
	Band 48 (3550.0 – 3700.0 MHz)	QPSK/16QAM/64QAM/256QAM			✓	✓	✓	✓

Bands	Modulation	SCS (KHz)	Bandwidth													
			5	10	15	20	25	30	40	50	60	70	80	90	100	
N2 FDD (1850.0 – 1910.0 MHz)	PI/2 BPSK QPSK 16QAM 64QAM 256QAM	15 30	✓	✓	✓	✓										
N5 FDD (824.0 – 849.0 MHz)	PV2 BPSK QPSK 16QAM 64QAM 256QAM	15 30 60	✓	✓	✓	✓										
N7 FDD (2500.0 – 2570.0 MHz)	PV2 BPSK QPSK 16QAM 64QAM 256QAM	15 30	✓	✓	✓	✓										
N25 FDD (1850.0 – 1915 MHz)	PV2 BPSK QPSK 16QAM 64QAM 256QAM	15 30	✓	✓	✓	✓										
N30 FDD (2305.0 – 2315.0 MHz)	PV2 BPSK QPSK 16QAM 64QAM 256QAM	15 30	✓	✓												
N38 TDD (2570.0 – 2620.0 MHz)	PV2 BPSK QPSK 16QAM 64QAM 256QAM	15 30 60	✓	✓	✓	✓										
N41 TDD (2496.0 – 2690.0 MHz)	PV2 BPSK QPSK 16QAM 64QAM 256QAM	15 30				✓			✓	✓	✓		✓	✓	✓	
N48 TDD (3550.0 – 3700.0 MHz)	PV2 BPSK QPSK 16QAM 64QAM 256QAM	15 30	✓	✓	✓	✓			✓	✓						
N66 FDD (1710.0 – 1780.0 MHz)	PV2 BPSK QPSK 16QAM 64QAM 256QAM	15 30	✓	✓	✓	✓			✓	✓						
N71 FDD (663.0 – 698.0 MHz)	PV2 BPSK QPSK 16QAM 64QAM 256QAM	15 30	✓	✓	✓	✓										
N77 TDD* (3450.0 – 3550.0 MHz) (3700.0 – 3980.0 MHz)	PV2 BPSK QPSK 16QAM 64QAM 256QAM	15 30		✓	✓	✓			✓	✓	✓		✓	✓	✓	
N78 TDD** (3700.0 – 3800.0 MHz)	PV2 BPSK QPSK 16QAM 64QAM 256QAM	15 30		✓	✓	✓			✓	✓	✓		✓	✓	✓	

*FCC limits 5G NR B77 to 3700-3980MHz

** FCC limits 5G NR B78 to 3700-3800MHz

6. Remarks and comments

1. The test report is a validation of the FCC TAS algorithm
2. This report consider only band n48, n71 and LTE 71. For other bands and TAS algorithm validation tests see report: 210825-01.TR04

7. Document Revision History

Revision #	Date	Modified by	Revision Details
Rev.00	2023-10-06	Y.HADDAD	First Issue
Rev.01	2023-12-14	Y.HADDAD	LTE71 and NR71 added upon customer request

Annex A. Test Setup Description

A.1 Measurement System

The conducted power measurement test setup is described in the following and illustrated in Figure 1

- The DUT is a Fibocom M2 FM350-GL Cellular Modem installed inside HP model HSN-I45C-3 Notebook PC.
- The control PC is used to configure the call box to send power control test sequences to the FM350-GL
- Uplink signal power is monitored by the spectrum analyzer and recorded by the PC with a time resolution of 25 msec which is substantially less than the power adjustment interval (Avg_SAR_Check_Period) of 0.05 sec used for FM350-GL .
- The values of Avg_SAR_Power are read from the FM350-GL by the PC at each Avg_SAR_Check_Period
- In addition to power results, the time sequence of power control commands and power samples are also recorded by the PC to enable results to be correlated and plotted. Uplink signal from the FM350-GL is fed through a 3 dB power splitter, which delivers an equal amount of signal to the spectrum analyser and the call box. The splitter has high isolation between the spectrum analyser and the call box. Due to different uplink/downlink frequencies and the zero span time-domain measurement used, interference of uplink and downlink signals are avoided.
- Path loss in the power measurement setup from the FM350-GL main antenna port to either the call box or the spectrum analyser is taken into account

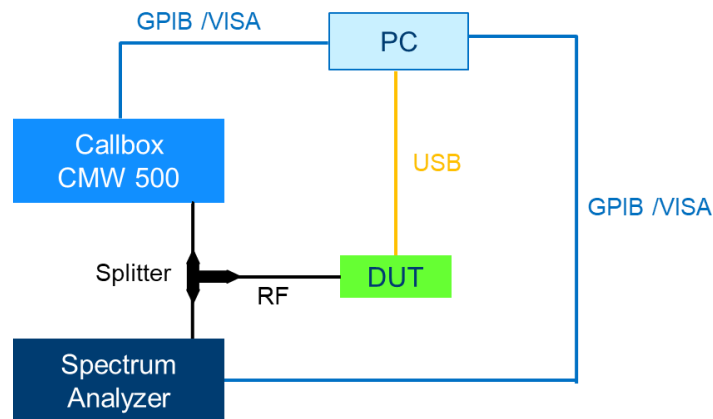

Figure 1 - Test Setup

A.2 Test Equipment List

The Equipments used for the conducted power measurement test setup are listed in Table below.

ID#	Device	Type/Model	Serial #	Manufacturer	Cal. Date	Cal. Due Date
023-001	Communication Tester	CMW500	169349	Rohde & Schwarz	N/A	N/A
023-000	Communication Tester	CMX500	101444	Rohde & Schwarz	N/A	N/A
265-000	Spectrum Analyzer	FSV30	101318	Rohde & Schwarz	2023-03-29	2025-03-29
455-001	RF Cable	-	-	-	2023-02-23	2024-02-23
455-002	RF Cable	-	-	-	2023-02-23	2024-02-23
455-003	RF Splitter	-	-	-	2023-02-23	2024-02-23

Annex B. Test Results

B.1 Summary of Test Cases

The following table lists the types of TAS algorithm validation tests performed and the corresponding Tables describing the test configurations and validation results.

Validation type	RAT	Configurations	Results	Verdict
Bands Compliance	NR	Table 1	Section 2	PASS
Bands Compliance	LTE	Table 2	Section 3	PASS

B.2 Bands Validation - NR

Table 1 - Test Cases for Bands Compliance of NR bands

Case	RAT	Band	Max_Power_DPR_OFF_dBm	Roll_Period_s	Check_Period_s	Avg_SAR_Upper_Thresh_dBm	Avg_SAR_Lower_Thresh_dBm	Max_Power_DPR_ON_dBm
1	NR	48	19	100	0.05	13	12	11
2	NR	71	23	100	0.05	20	19	18

Note: The Average power is calculated using the measured instantaneous power and compared to the UpperThreshold Plus Tune-Up Tolerance. This is applied for all the test cases in this report.

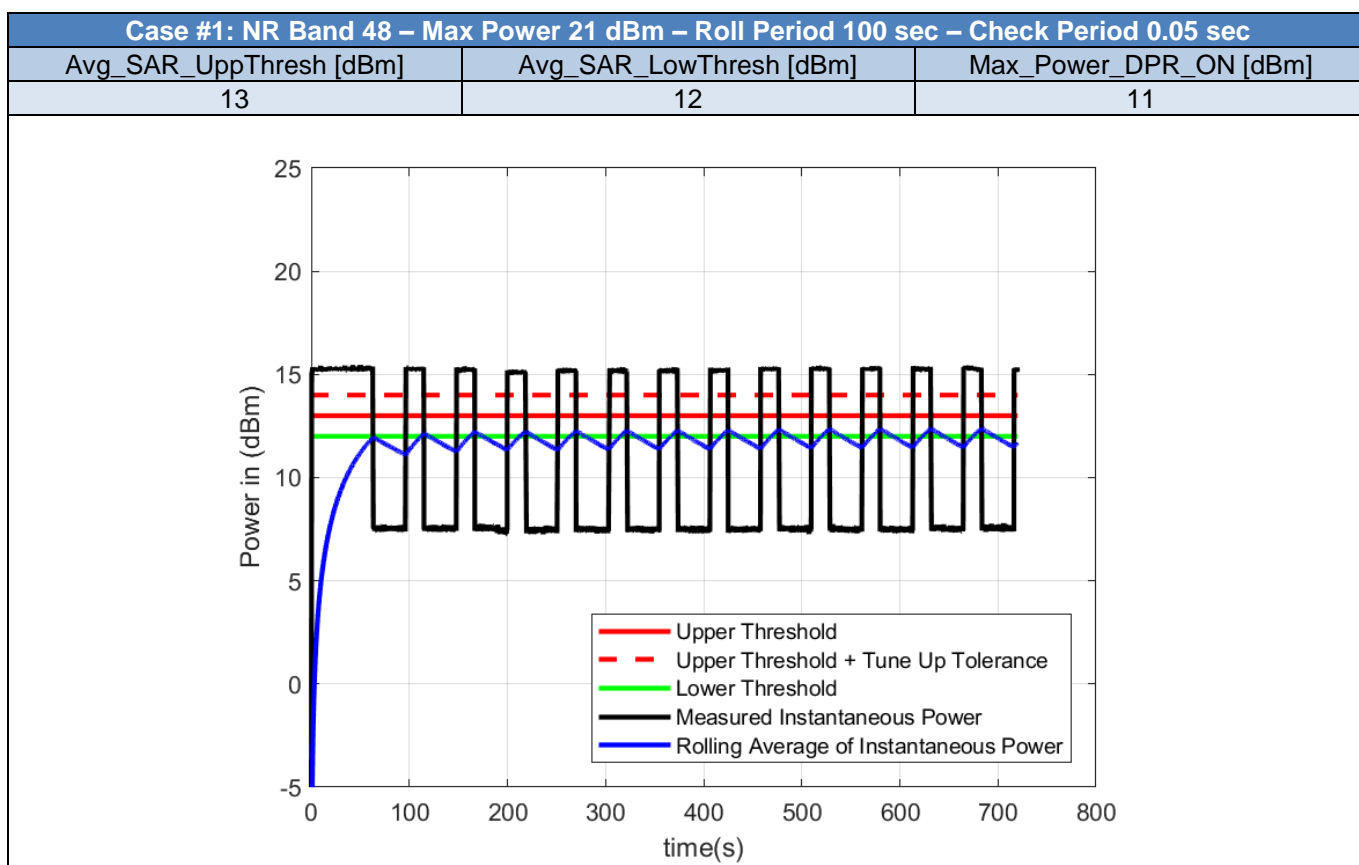

Case #2: NR Band 71 – Max Power 23 dBm – Roll Period 100 sec – Check Period 0.05 sec		
Avg_SAR_UppThresh [dBm]	Avg_SAR_LowThresh [dBm]	Max_Power_DPR_ON [dBm]
20	19	18

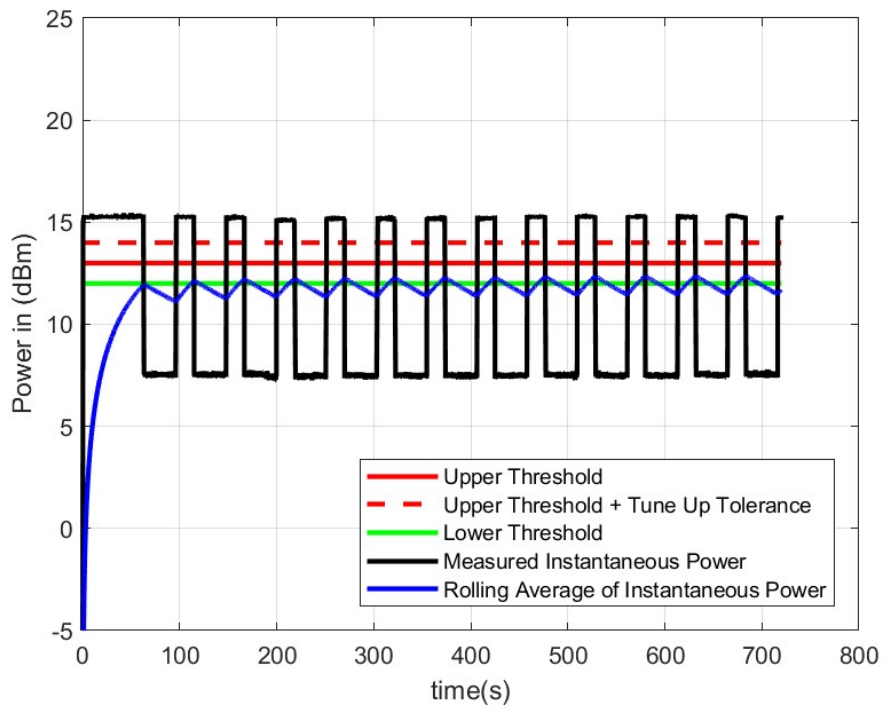

B.3 Bands Validation - LTE

Table 2 - Test Cases for Bands Compliance of LTE bands

Case	RAT	Band	Max_Power_DPR_OFF_dBm	Roll_Period_s	Check_Period_s	Avg_SAR_UploadThresh_dBm	Avg_SAR_LowThresh_dBm	Max_Power_DPR_ON_dBm
1	LTE	71	23	100	0.05	20	19	18

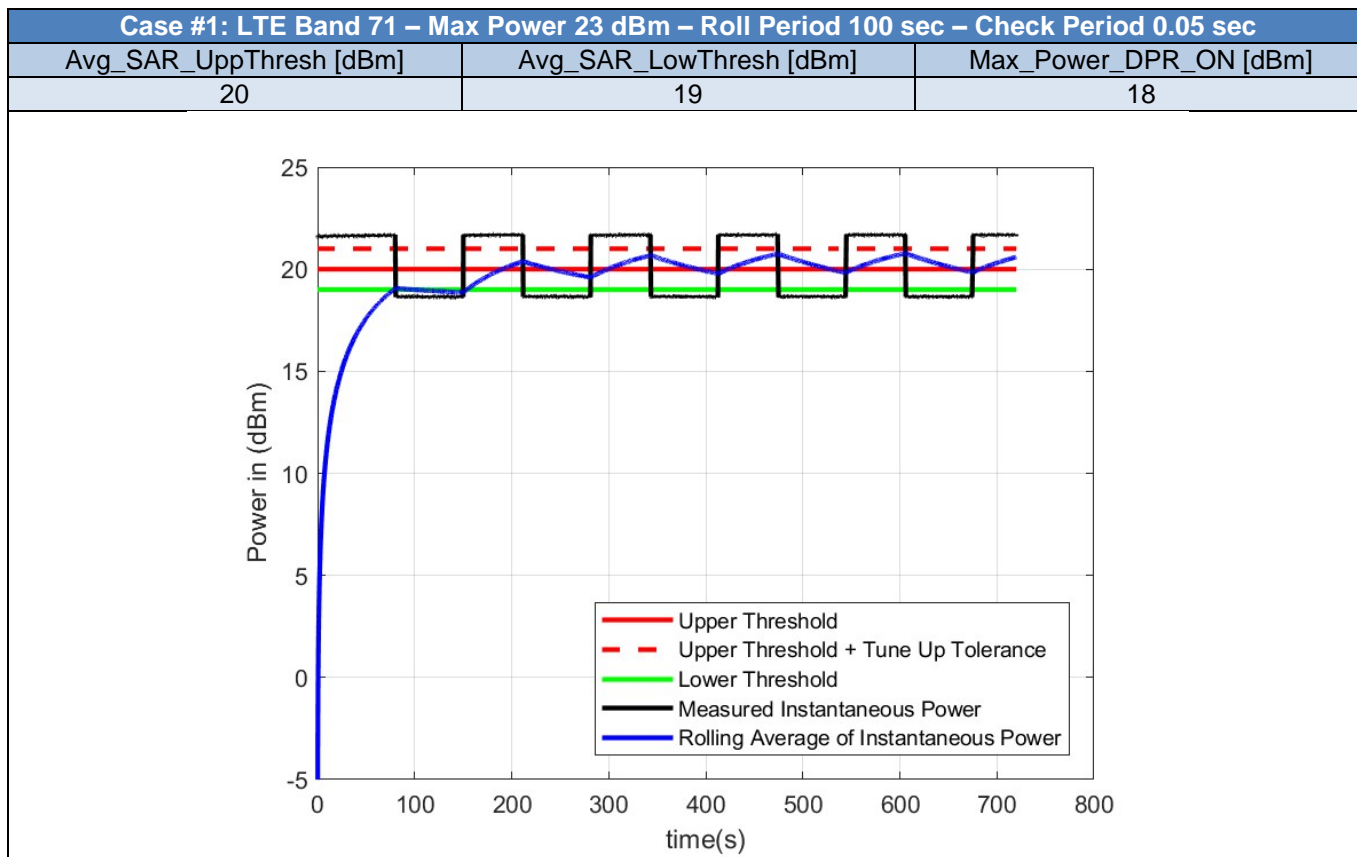

End of the report

This page is left intentionally blank and marks the last page of the test report.