



**FCC CFR47 PART 15 SUBPART C
INDUSTRY CANADA RSS-210 ISSUE 8**

CERTIFICATION TEST REPORT

FOR

802.11abgn 2X2 MIMO + BT/BLE RADIO MODULE

MODEL NUMBER: DWM-W095A

FCC ID: EW4DMMW095A

IC: 4250A-DMMW095A

REPORT NUMBER: 13J14910-2

ISSUE DATE: APRIL 19, 2013

Prepared for

**MITSUMI ELECTRIC CO., LTD.
1601, SAKAI, ASUGI-SHI,
KANAGAWA, 243-8533 JAPAN**

Prepared by

**UL VERIFICATION SERVICES INC.
47173 BENICIA STREET
FREMONT, CA 94538, U.S.A.
TEL: (510) 771-1000
FAX: (510) 661-0888**



NVLAP LAB CODE 200065-0

Revision History

<u>Rev.</u>	<u>Issue Date</u>	<u>Revisions</u>	<u>Revised By</u>
--	04/19/13	Initial Issue	F. Ibrahim

TABLE OF CONTENTS

1. ATTESTATION OF TEST RESULTS	5
2. TEST METHODOLOGY	6
3. FACILITIES AND ACCREDITATION	6
4. CALIBRATION AND UNCERTAINTY	6
4.1. MEASURING INSTRUMENT CALIBRATION	6
4.2. SAMPLE CALCULATION	6
4.3. MEASUREMENT UNCERTAINTY	6
5. EQUIPMENT UNDER TEST	7
5.1. DESCRIPTION OF EUT	7
5.2. MAXIMUM OUTPUT POWER	7
5.3. DESCRIPTION OF AVAILABLE ANTENNAS	7
5.4. SOFTWARE AND FIRMWARE	7
5.5. WORST-CASE CONFIGURATION AND MODE	7
5.6. DESCRIPTION OF TEST SETUP	8
6. TEST AND MEASUREMENT EQUIPMENT	10
7. ANTENNA PORT TEST RESULTS	11
7.1. ON TIME AND DUTY CYCLE	11
7.2. BASIC DATA RATE GFSK MODULATION	13
7.2.1. 20 dB AND 99% BANDWIDTH	13
7.2.2. HOPPING FREQUENCY SEPARATION	18
7.2.3. NUMBER OF HOPPING CHANNELS	20
7.2.4. AVERAGE TIME OF OCCUPANCY	23
7.2.5. OUTPUT POWER	27
7.2.6. AVERAGE POWER	30
7.2.7. CONDUCTED SPURIOUS EMISSIONS	31
7.3. ENHANCED DATA RATE 8PSK MODULATION	36
7.3.1. 20 dB AND 99% BANDWIDTH	36
7.3.2. HOPPING FREQUENCY SEPARATION	41
7.3.3. NUMBER OF HOPPING CHANNELS	42
7.3.4. AVERAGE TIME OF OCCUPANCY	46
7.3.5. OUTPUT POWER	50
7.3.6. AVERAGE POWER	53
7.3.7. CONDUCTED SPURIOUS EMISSIONS	54
8. RADIATED TEST RESULTS	59
8.1. LIMITS AND PROCEDURE	59
8.2. TRANSMITTER ABOVE 1 GHz	60
8.2.1. BASIC DATA RATE GFSK MODULATION	60
8.2.2. ENHANCED DATA RATE 8PSK MODULATION	73

8.3. WORST-CASE BELOW 1 GHz	86
9. AC POWER LINE CONDUCTED EMISSIONS.....	89
10. SETUP PHOTOS.....	93

1. ATTESTATION OF TEST RESULTS

COMPANY NAME: MITSUMI ELECTRIC CO., LTD.
1601, SAKAI, ASUGI-SHI,
KANAGAWA, 243-8533 JAPAN

EUT DESCRIPTION: 802.11abgn 2X2 MIMO + BT/BLE RADIO MODULE

MODEL: DWM-W095A

SERIAL NUMBER: B4-29 & B4-01

DATE TESTED: APRIL 01 – 18, 2013

APPLICABLE STANDARDS	
STANDARD	TEST RESULTS
CFR 47 Part 15 Subpart C	Pass
INDUSTRY CANADA RSS-210 Issue 8 Annex 8	Pass
INDUSTRY CANADA RSS-GEN Issue 3	Pass

UL Verification Services Inc. tested the above equipment in accordance with the requirements set forth in the above standards. All indications of Pass/Fail in this report are opinions expressed by UL Verification Services Inc. based on interpretations and/or observations of test results. Measurement Uncertainties were not taken into account and are published for informational purposes only. The test results show that the equipment tested is capable of demonstrating compliance with the requirements as documented in this report.

Note: The results documented in this report apply only to the tested sample, under the conditions and modes of operation as described herein. This document may not be altered or revised in any way unless done so by UL Verification Services Inc. and all revisions are duly noted in the revisions section. Any alteration of this document not carried out by UL Verification Services Inc. will constitute fraud and shall nullify the document. This report must not be used by the client to claim product certification, approval, or endorsement by NVLAP, NIST, any agency of the Federal Government, or any agency of any government.

Approved & Released For
UL Verification Services Inc. By:

Tested By:



FRANK IBRAHIM
WiSE PROGRAM MANAGER
UL Verification Services Inc.

CHRIS XIONG
EMC ENGINEER
UL Verification Services Inc.

2. TEST METHODOLOGY

The tests documented in this report were performed in accordance with ANSI C63.10-2009, FCC CFR 47 Part 2, FCC CFR 47 Part 15, RSS-GEN Issue 3, and RSS-210 Issue 8.

3. FACILITIES AND ACCREDITATION

The test sites and measurement facilities used to collect data are located at 47173 Benicia Street, Fremont, California, USA.

UL Verification Services Inc. is accredited by NVLAP, Laboratory Code 200065-0. The full scope of accreditation can be viewed at <http://www.ccsemc.com>.

4. CALIBRATION AND UNCERTAINTY

4.1. MEASURING INSTRUMENT CALIBRATION

The measuring equipment utilized to perform the tests documented in this report has been calibrated in accordance with the manufacturer's recommendations, and is traceable to recognized national standards.

4.2. SAMPLE CALCULATION

Where relevant, the following sample calculation is provided:

$$\begin{aligned} \text{Field Strength (dBuV/m)} &= \text{Measured Voltage (dBuV)} + \text{Antenna Factor (dB/m)} + \\ &\text{Cable Loss (dB)} - \text{Preamp Gain (dB)} \\ 36.5 \text{ dBuV} + 18.7 \text{ dB/m} + 0.6 \text{ dB} - 26.9 \text{ dB} &= 28.9 \text{ dBuV/m} \end{aligned}$$

4.3. MEASUREMENT UNCERTAINTY

Where relevant, the following measurement uncertainty levels have been estimated for tests performed on the apparatus:

PARAMETER	UNCERTAINTY
Conducted Disturbance, 0.15 to 30 MHz	3.52 dB
Radiated Disturbance, 30 to 1000 MHz	4.94 dB

Uncertainty figures are valid to a confidence level of 95%.

5. EQUIPMENT UNDER TEST

5.1. DESCRIPTION OF EUT

The EUT is an 802.11abgn 2X2 MIMO + BT/BLE Radio Module

The radio module is manufactured by Mitsumi.

5.2. MAXIMUM OUTPUT POWER

The transmitter has a maximum peak conducted output power as follows:

Frequency Range (MHz)	Mode	Output Power (dBm)	Output Power (mW)
2402 - 2480	Basic GFSK	11.05	12.74
2402 - 2480	Enhanced 8PSK	10.72	11.80

5.3. DESCRIPTION OF AVAILABLE ANTENNAS

The radio utilizes a PIFA antenna, with a maximum gain of 3.0 dBi.

5.4. SOFTWARE AND FIRMWARE

The EUT driver software installed in the host support equipment during was testing BCM4324B3_002.004.006.0012.0017.hcd.

The test utility software used during testing was Bluetool, rev.1.6.1.5.

5.5. WORST-CASE CONFIGURATION AND MODE

The fundamental of the EUT was investigated in three orthogonal orientations X, Y, Z. It was determined that X orientation was worst-case orientation; therefore, all final radiated testing was performed with the EUT in X orientation.

5.6. DESCRIPTION OF TEST SETUP

SUPPORT EQUIPMENT

Support Equipment List				
Description	Manufacturer	Model	Serial Number	FCC ID
Laptop	Fujitsu	Q2010	R6609927	DoC
AC Adaptor	Fujitsu	SEC80N2-16	N/A	DoC
USB to UART Converter Card	Mitsumi	SKCL-F4	N/A	N/A
DC Power Supply	Lamda	LA-300	LA3-AA30-103 2676	N/A

I/O CABLES

I/O CABLE LIST						
Cable No.	Port	# of Identical Ports	Connector Type	Cable Type	Cable Length	Remarks
1	AC	2	US 115V	Shielded	1.5m	NA
2	DC	2	DC	Un-shielded	1.5m	NA
3	USB	1	USB	Un-shielded	1.0m	NA

TEST SETUP

The EUT was tested as an external module that installed on an USB to UART board connected to a host Laptop PC via USB cable. Test software exercised the radio card.

SETUP DIAGRAM

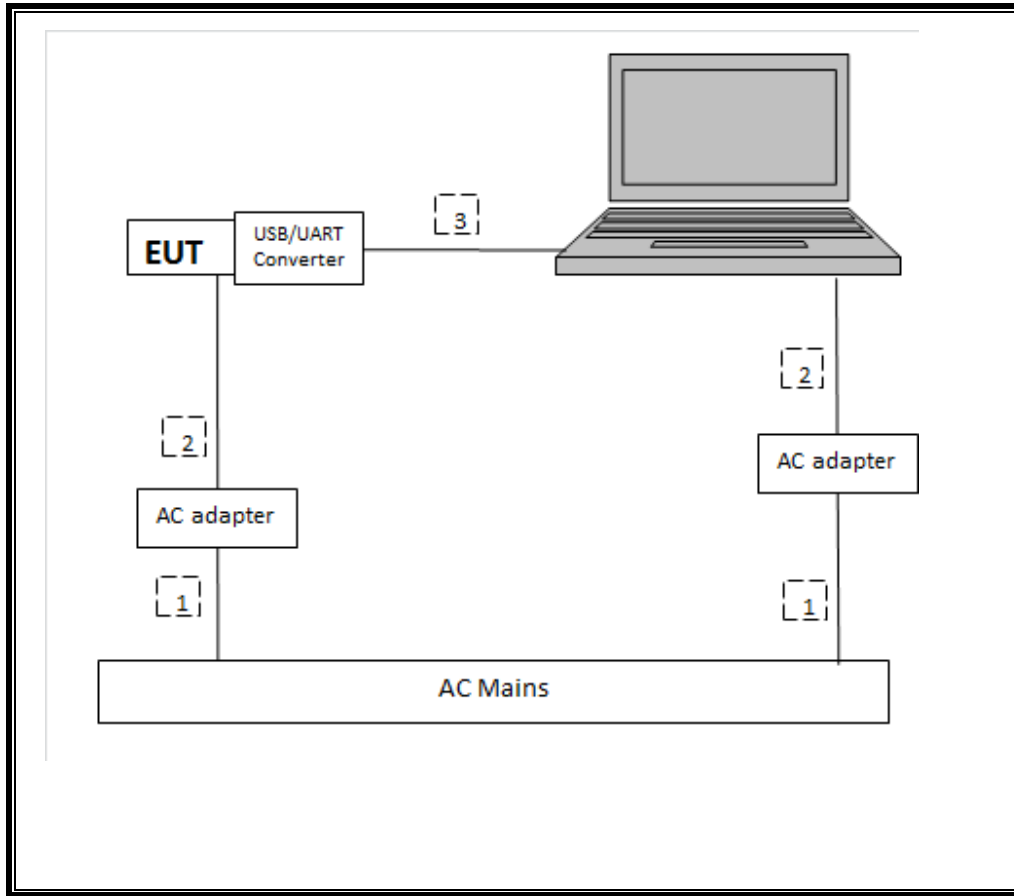

6. TEST AND MEASUREMENT EQUIPMENT

The following test and measurement equipment was utilized for the tests documented in this report:

Test Equipment List					
Description	Manufacturer	Model	Asset	Cal Date	Cal Due
Spectrum Analyzer, 44 GHz	Agilent / HP	E4446A	C00996	05/11/12	05/11/13
Spectrum Analyzer, 26.5 GHz	Agilent / HP	E4440A	C01161	05/02/12	05/02/13
EMI Test Receiver, 30 MHz	R & S	ESHS 20	N02396	08/08/12	08/08/13
Antenna, Bilog, 30MHz-1 GHz	Sunol Sciences	JB1	C01016	08/14/12	08/14/13
Antenna, Horn, 18 GHz	ETS	3117	C01006	12/11/12	12/11/13
Antenna, Horn, 26.5 GHz	ARA	MWH-1826/B	C00946	11/12/12	11/12/13
Preamplifier, 1300 MHz	Agilent / HP	8447D	C00558	03/23/13	03/23/14
Preamplifier, 26.5 GHz	Agilent / HP	8449B	C00749	10/19/12	10/19/13
Peak Power Meter	Agilent / HP	E4416A	C00963	12/13/11	12/13/13
Peak Power Sensor	HP	E9327A	C00964	12/13/12	12/13/13
Reject Filter, 2.4-2.5 GHz	Micro-Tronics	BRC13192	N02683	CNR	CNR
LISN, 30 MHz	FCC	50/250-25-2	N02396	08/08/12	08/08/13

7. ANTENNA PORT TEST RESULTS

7.1. ON TIME AND DUTY CYCLE

LIMITS

None; for reporting purposes only.

PROCEDURE

KDB 558074 Zero-Span Spectrum Analyzer Method.

RESULTS

Mode	ON Time B (msec)	Period (msec)	Duty Cycle x (linear)	Duty Cycle (%)	Duty Cycle Correction Factor (dB)	1/T Minimum VBW (kHz)
GFSK	2.908	3.747	0.776	77.6%	1.10	0.344
8PSK	2.925	3.733	0.784	78.4%	1.06	0.342

DUTY CYCLE GFSK MODE

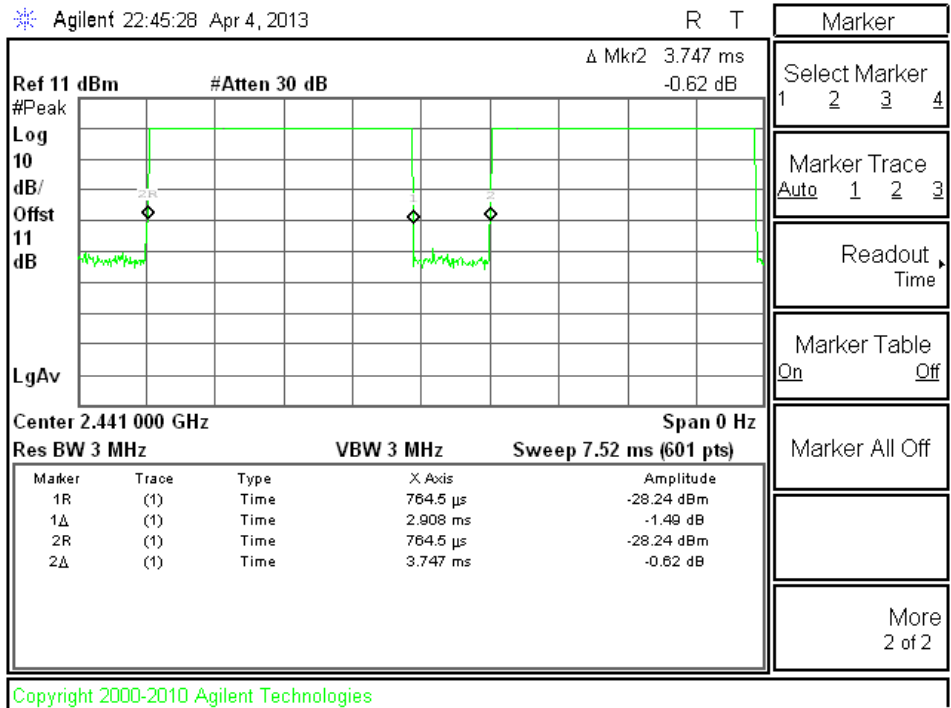

DUTY CYCLE 8PSK

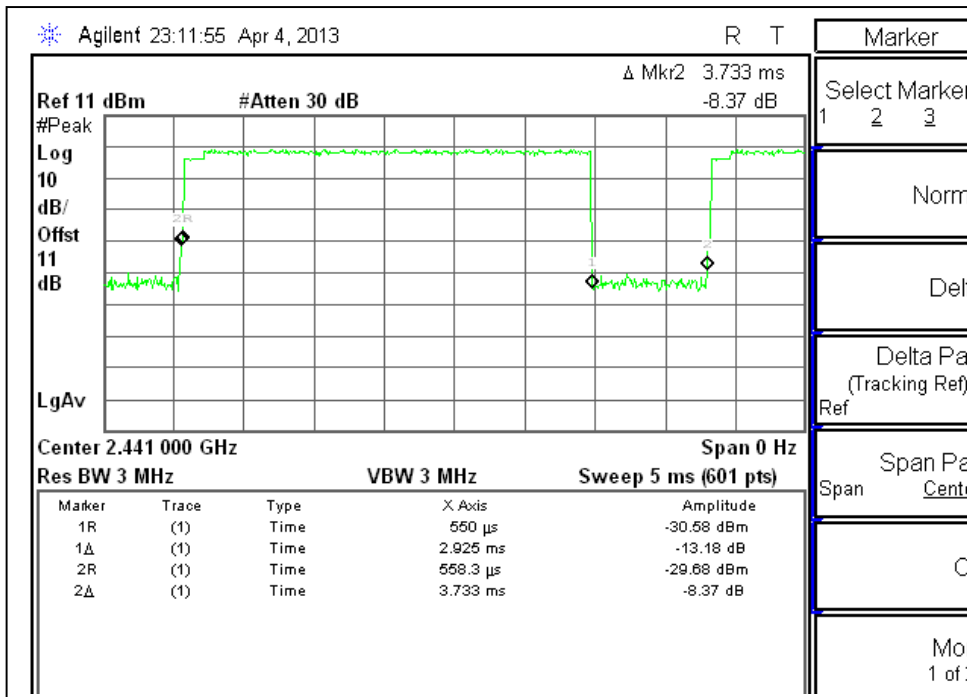

7.2. BASIC DATA RATE GFSK MODULATION

7.2.1. 20 dB AND 99% BANDWIDTH

LIMIT

None; for reporting purposes only.

TEST PROCEDURE

The transmitter output is connected to a spectrum analyzer. The RBW is set to $\geq 1\%$ of the 20 dB bandwidth. The VBW is set to \geq RBW. The sweep time is coupled.

RESULTS

Channel	Frequency (MHz)	20 dB Bandwidth (kHz)	99% Bandwidth (kHz)
Low	2402	734.754	830.7140
Middle	2441	736.089	832.6193
High	2480	736.315	830.8406

20 dB BANDWIDTH

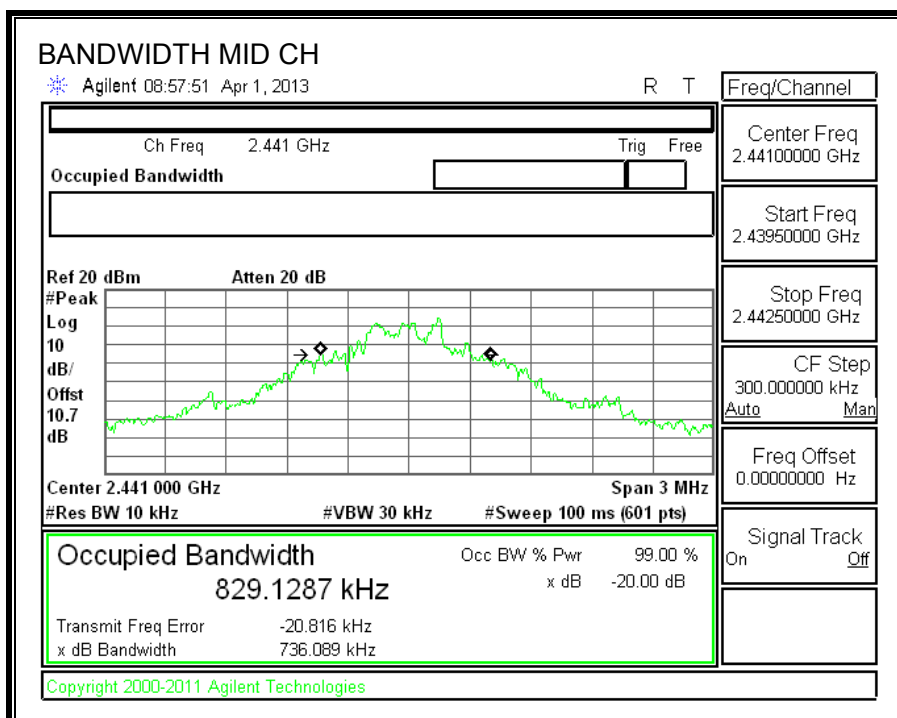
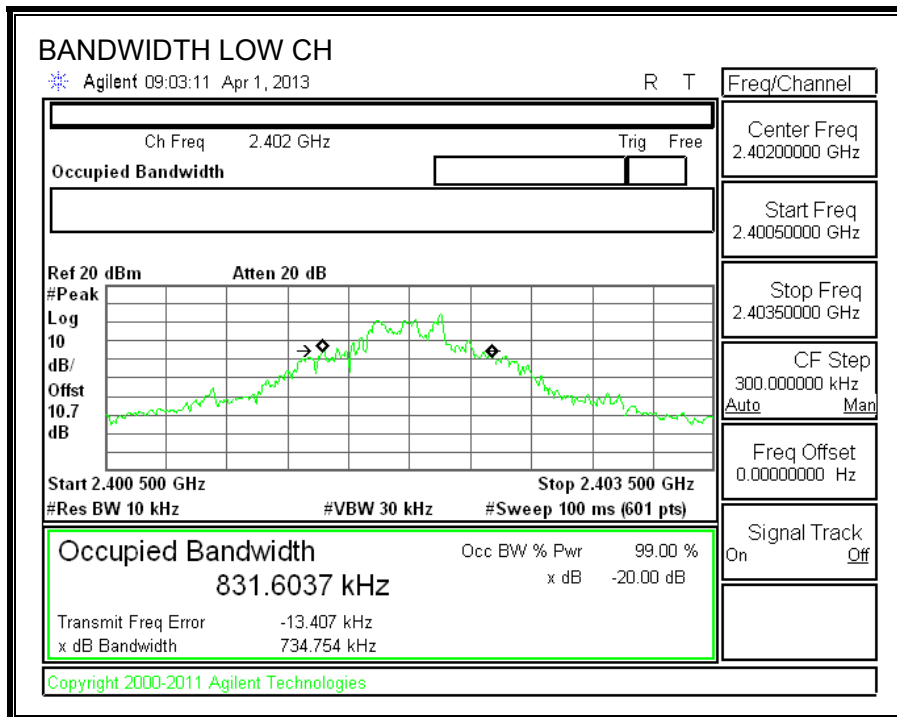

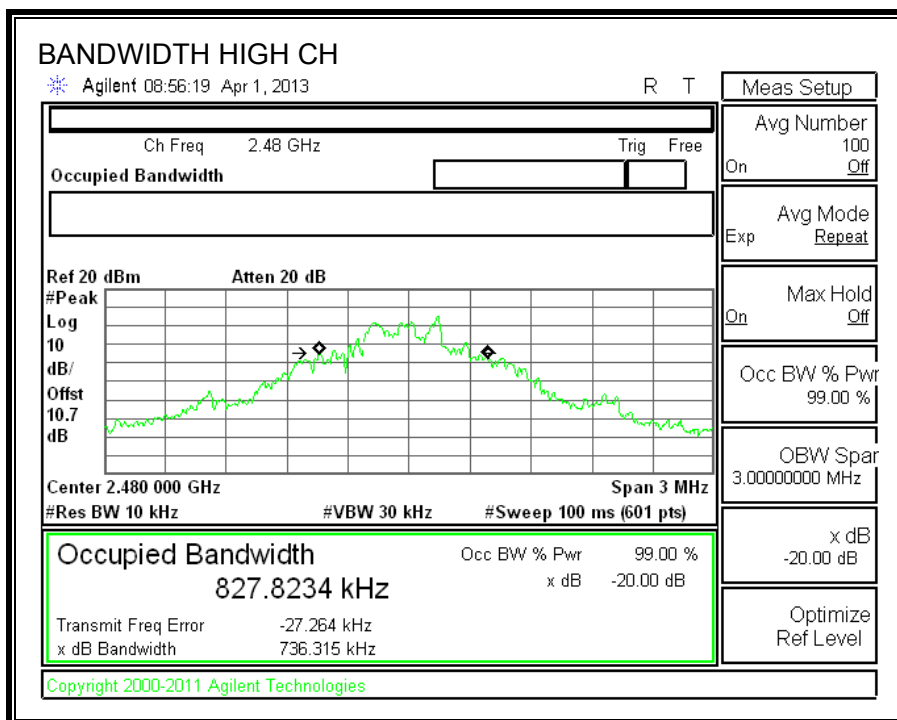

99% BANDWIDTH

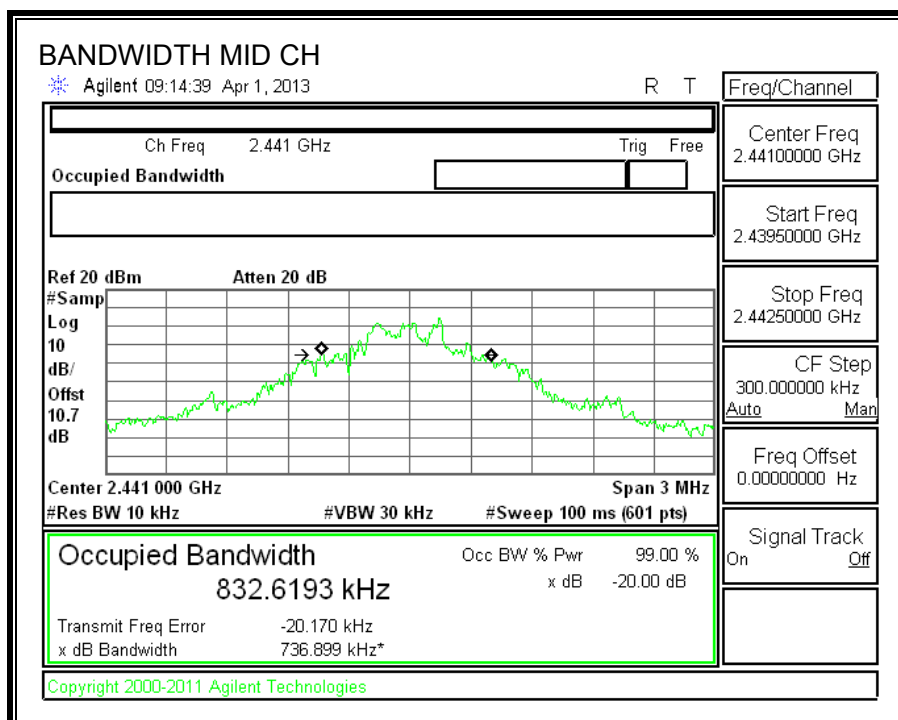
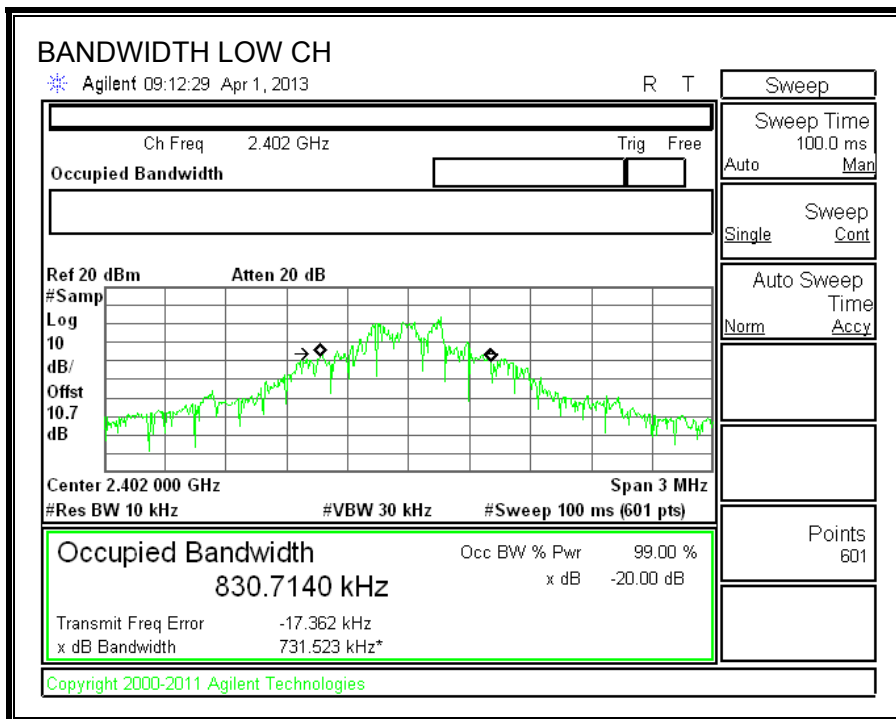

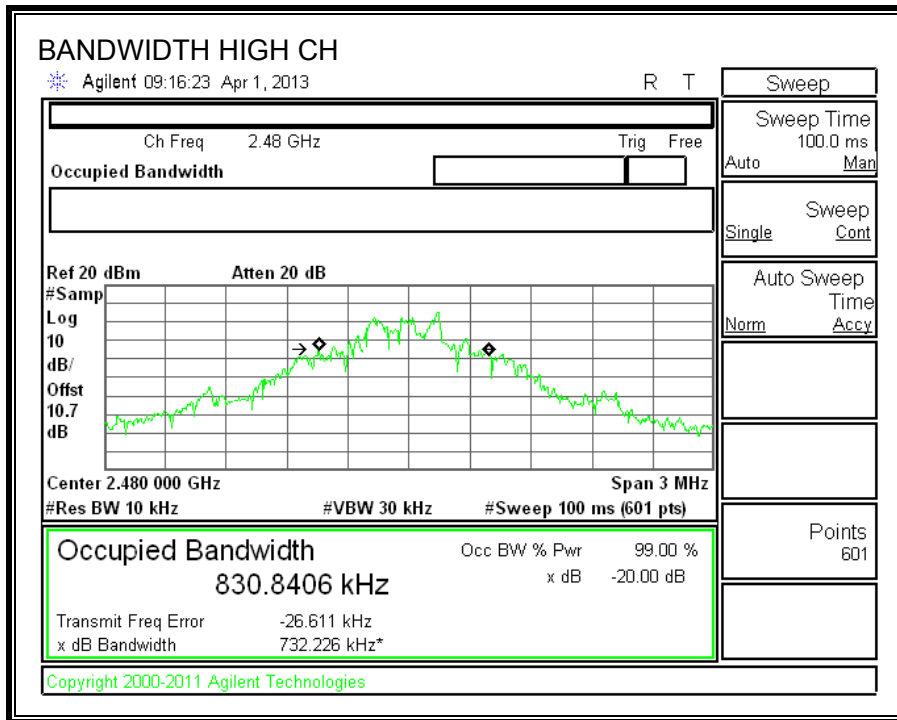

7.2.2. HOPPING FREQUENCY SEPARATION

LIMIT

FCC §15.247 (a) (1)

IC RSS-210 A8.1 (b)

Frequency hopping systems shall have hopping channel carrier frequencies separated by a minimum of 25 kHz or the 20 dB bandwidth of the hopping channel, whichever is greater.

Alternatively, frequency hopping systems operating in the 2400-2483.5 MHz band may have hopping channel carrier frequencies that are separated by 25 kHz or two-thirds of the 20 dB bandwidth of the hopping channel, whichever is greater, provided the systems operate with an output power no greater than 125 mW.

TEST PROCEDURE

The transmitter output is connected to a spectrum analyzer. The RBW is set to 300 kHz and the VBW is set to 300 kHz. The sweep time is coupled.

RESULTS

HOPPING FREQUENCY SEPARATION

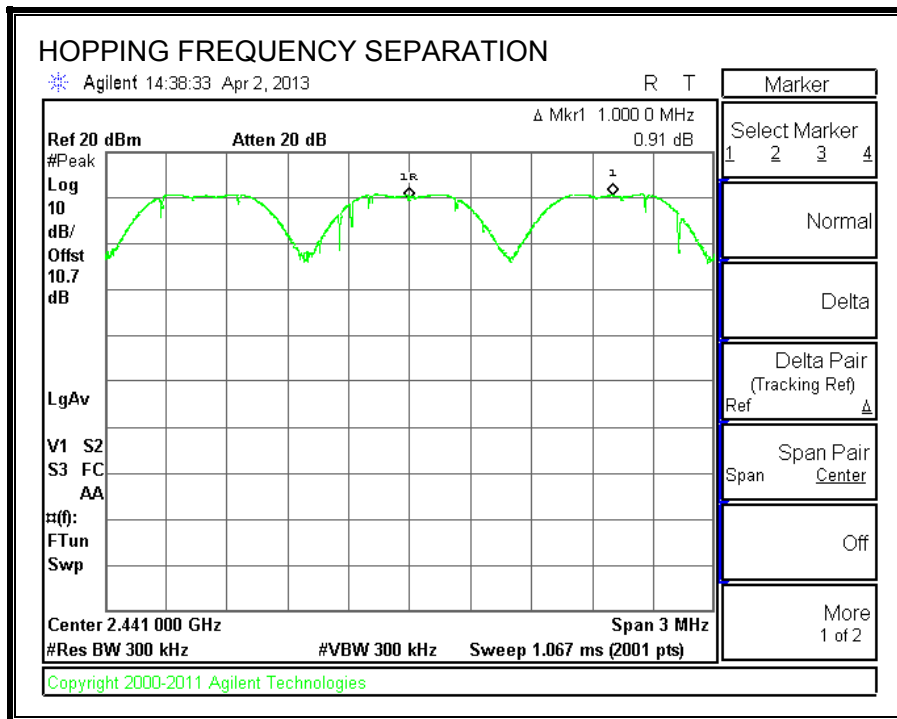

7.2.3. NUMBER OF HOPPING CHANNELS

LIMIT

FCC §15.247 (a) (1) (iii)

IC RSS-210 A8.1 (d)

Frequency hopping systems in the 2400 – 2483.5 MHz band shall use at least 15 non-overlapping channels.

TEST PROCEDURE

The transmitter output is connected to a spectrum analyzer. The span is set to cover the entire authorized band, in either a single sweep or in multiple contiguous sweeps. The RBW is set to a maximum of 1 % of the span. The analyzer is set to Max Hold.

RESULTS

The EUT is capable of adaptive frequency hopping.

Number of channels for normal hopping mode = 79

Number of channels for AFH mode, as declared by the client = 20

NUMBER OF HOPPING CHANNELS

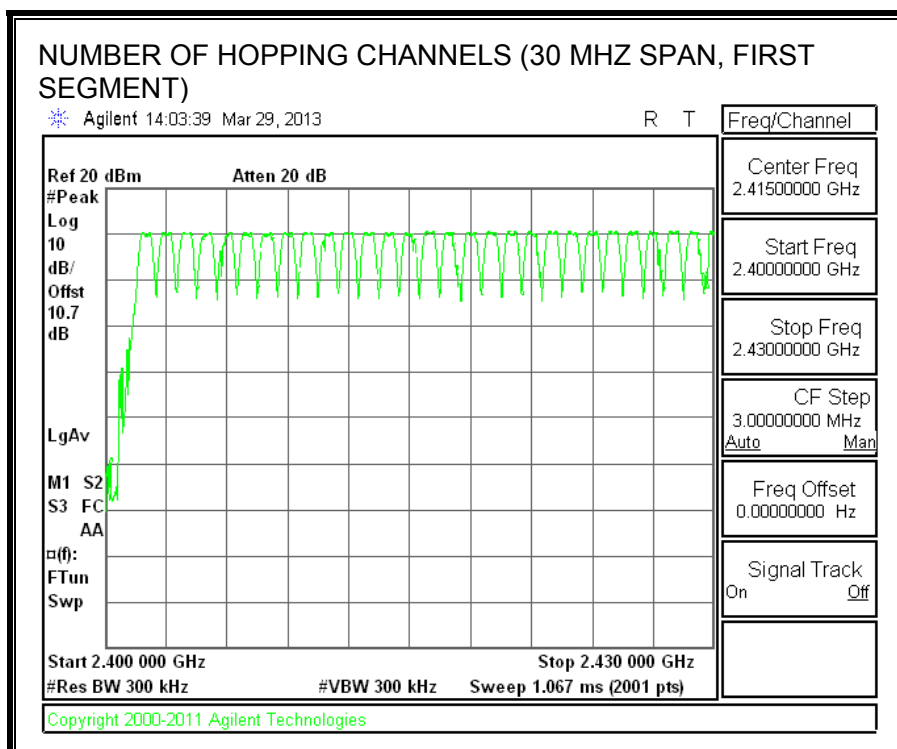
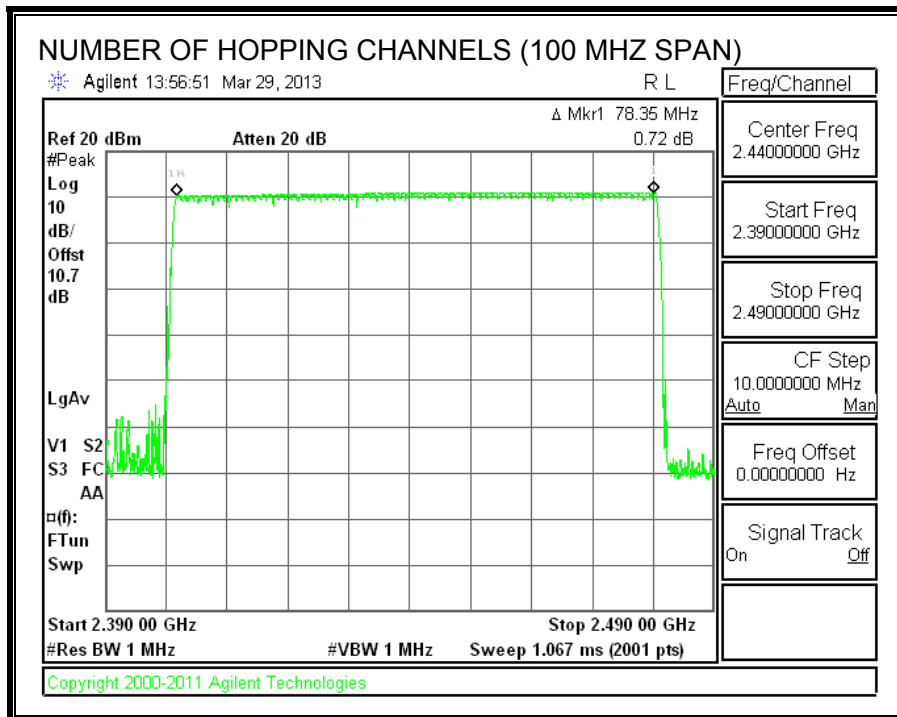

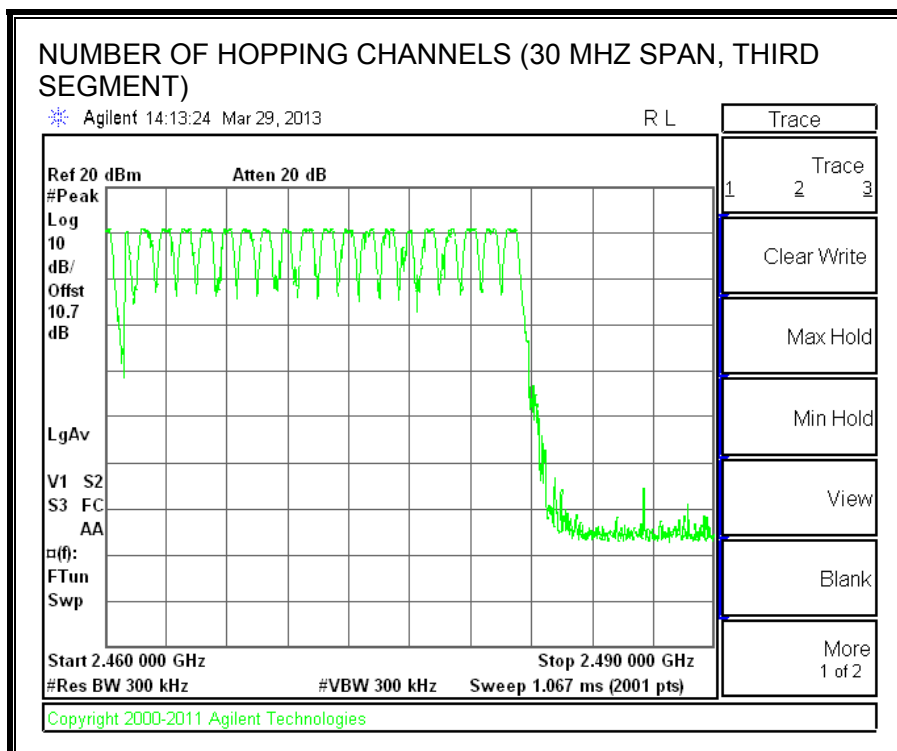
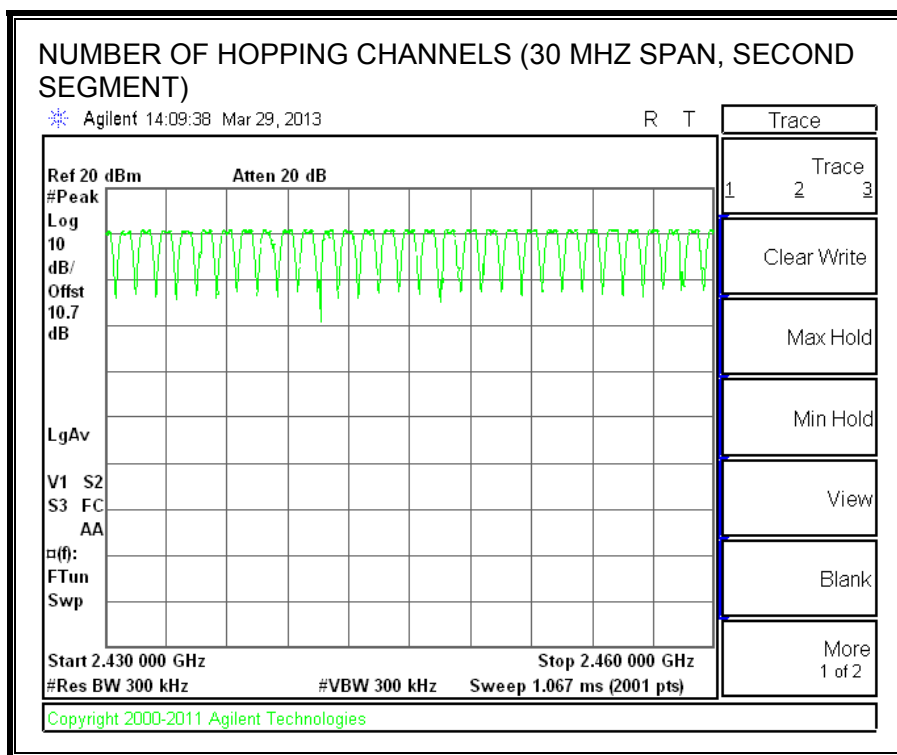

7.2.4. AVERAGE TIME OF OCCUPANCY

LIMIT

FCC §15.247 (a) (1) (iii)

IC RSS-210 A8.1 (d)

The average time of occupancy on any channel shall not be greater than 0.4 seconds within a period of 0.4 seconds multiplied by the number of hopping channels employed.

TEST PROCEDURE

The transmitter output is connected to a spectrum analyzer. The span is set to 0 Hz, centered on a single, selected hopping channel. The width of a single pulse is measured in a fast scan. The number of pulses is measured in a 3.16 second scan, to enable resolution of each occurrence.

The average time of occupancy in the specified 31.6 second period (79 channels * 0.4 s) is equal to $10 * (\# \text{ of pulses in } 3.16 \text{ s}) * \text{ pulse width}$.

For AFH mode, the average time of occupancy in the specified 8 second period (20 channels * 0.4 seconds) is equal to $10 * (\# \text{ of pulses in } 0.8 \text{ s}) * \text{ pulse width}$.

RESULTS

DH Packet	Pulse Width (msec)	Number of Pulses in 3.16 seconds	Average Time of Occupancy (sec)	Limit (sec)	Margin (sec)
GFSK Normal Mode					
DH1	0.4051	32	0.130	0.4	-0.270
DH3	1.673	17	0.284	0.4	-0.116
DH5	2.905	11	0.320	0.4	-0.080
GFSK AFH Mode					
DH Packet	Pulse Width (msec)	Number of Pulses in 0.8 seconds	Average Time of Occupancy (sec)	Limit (sec)	Margin (sec)
DH1	0.4051	64	0.259	0.4	-0.141
DH3	1.673	18	0.301	0.4	-0.099
DH5	2.905	12	0.349	0.4	-0.051

PULSE WIDTH - DH1

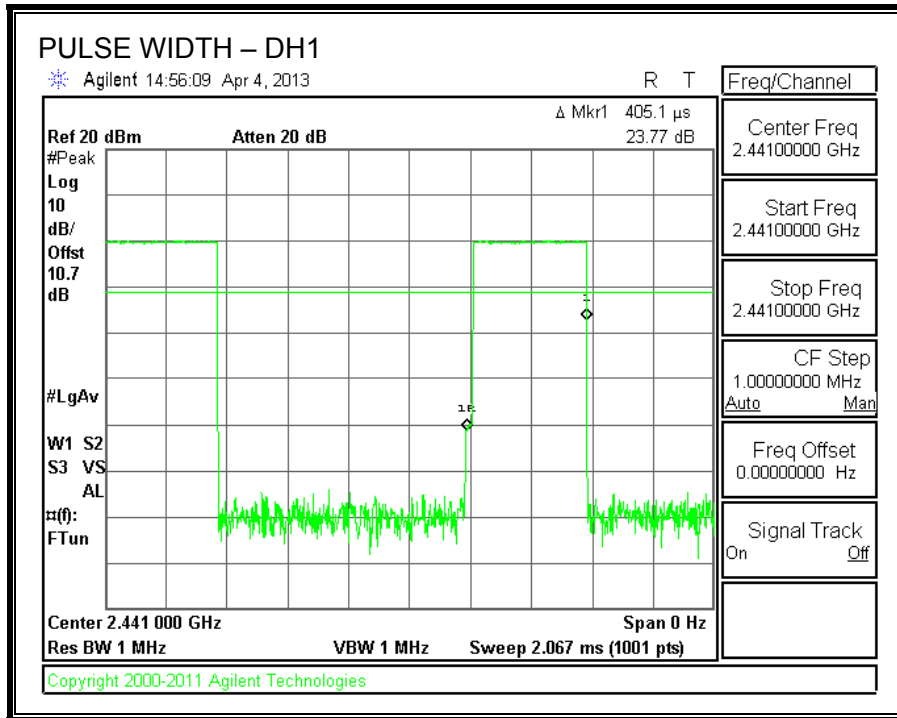

NUMBER OF PULSES IN 3.16 SECOND OBSERVATION PERIOD - DH1

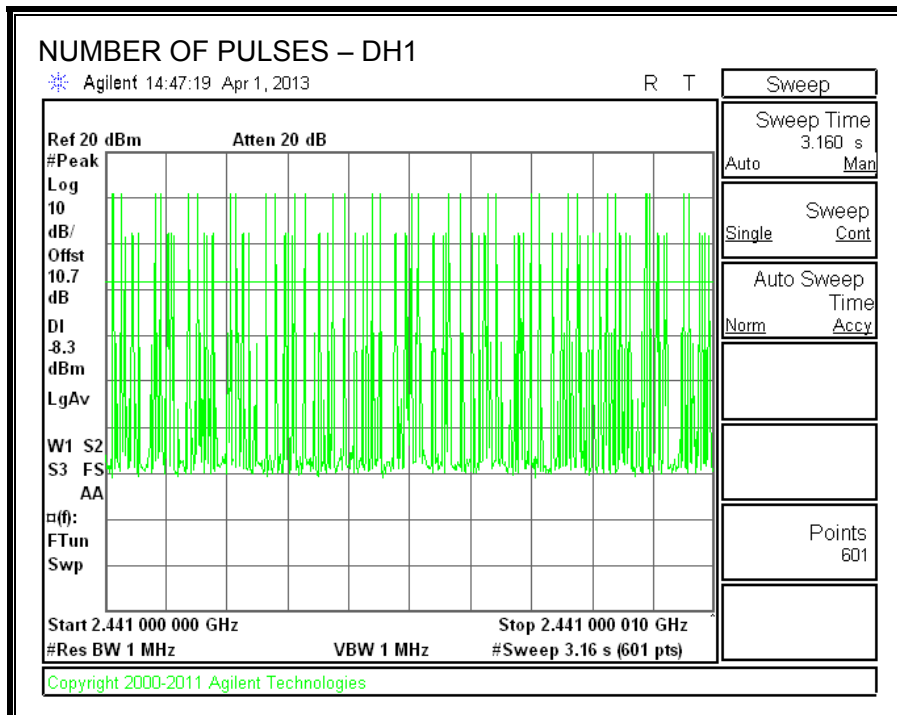

PULSE WIDTH – DH3

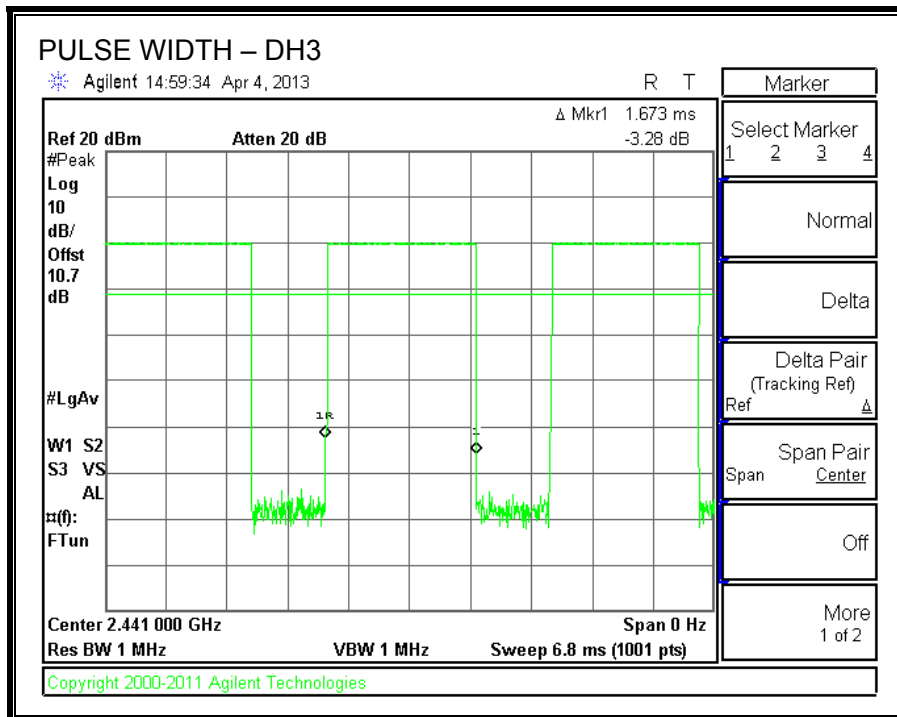

NUMBER OF PULSES IN 3.16 SECOND OBSERVATION PERIOD – DH3

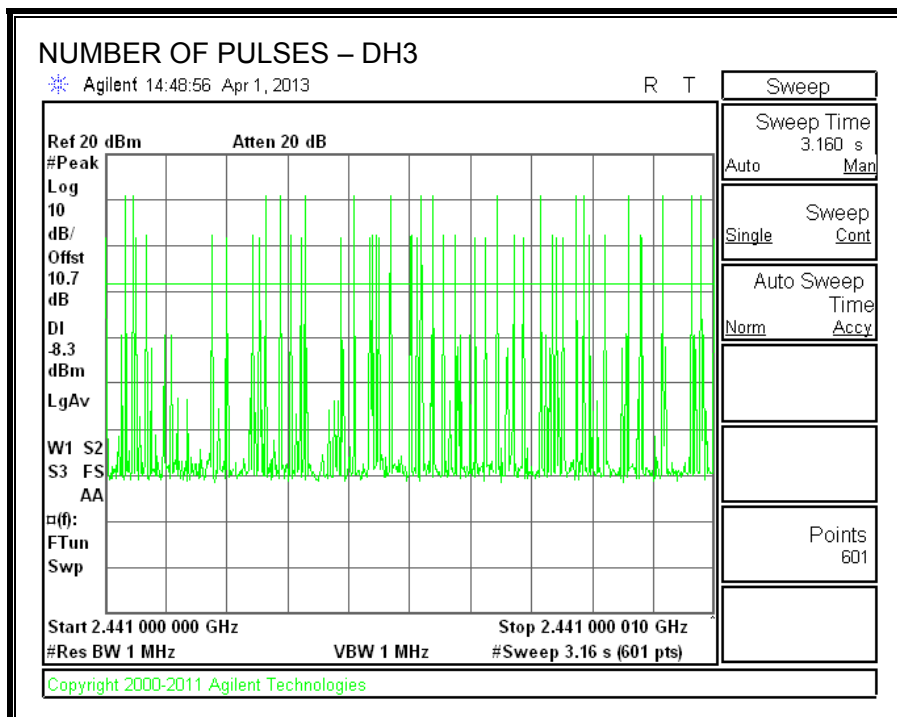

PULSE WIDTH – DH5

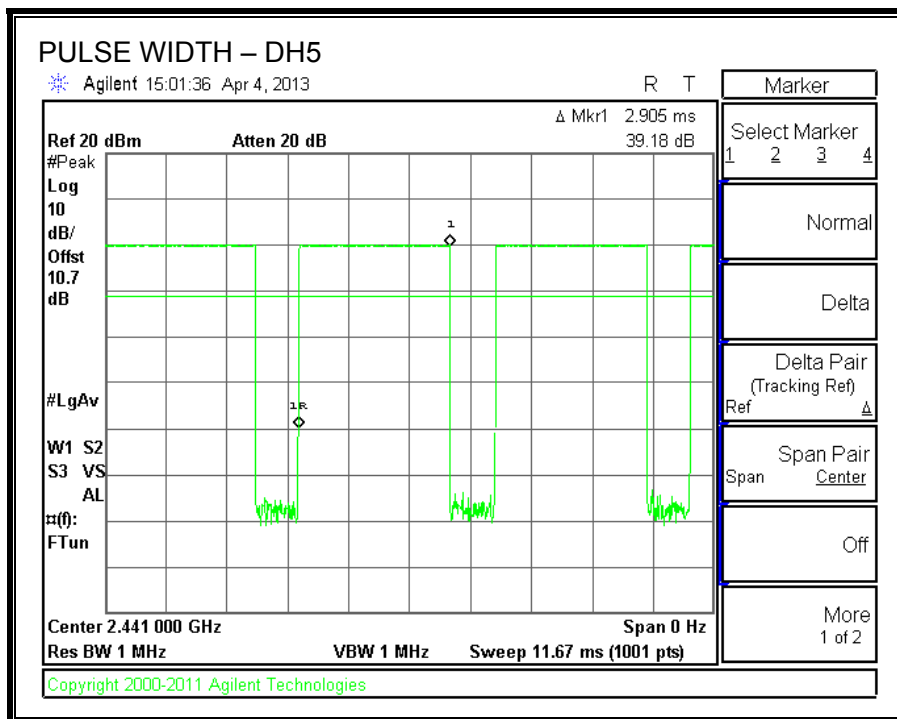

NUMBER OF PULSES IN 3.16 SECOND OBSERVATION PERIOD – DH5

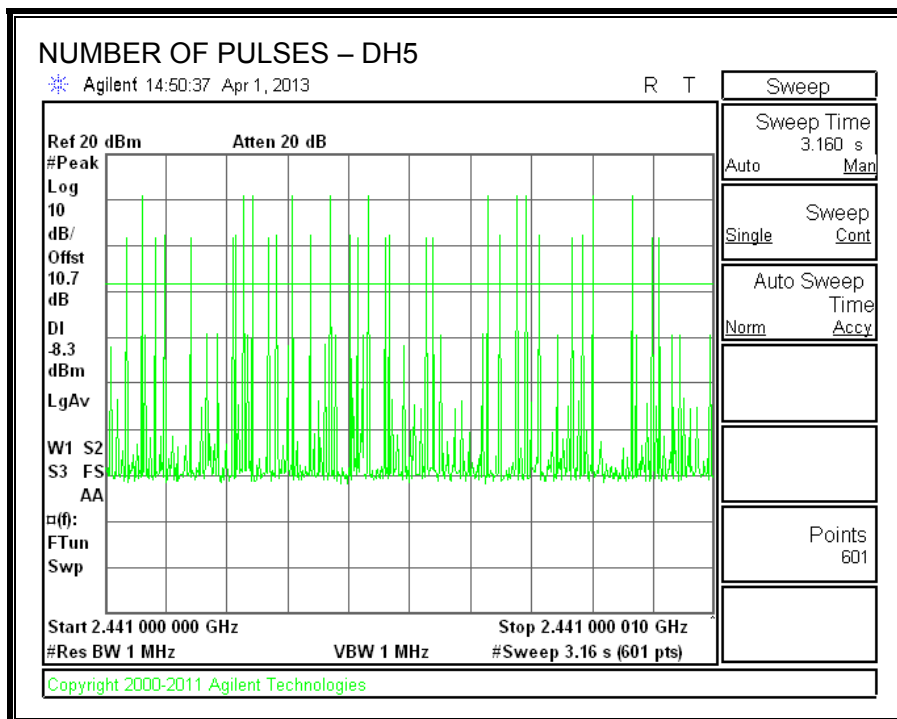

7.2.5. OUTPUT POWER

LIMIT

§15.247 (b) (1)

RSS-210 Issue 7 Clause A8.4

§15.247 (b) (1) For frequency hopping systems operating in the 2400-2483.5 MHz band employing at least 75 non-overlapping hopping channels, and all frequency hopping systems in the 5725-5850 MHz band: 1 watt. For all other frequency hopping systems in the 2400-2483.5 MHz band: 0.125 watts.

The maximum antenna gain is less than 6 dBi, therefore the limit is 30 dBm.

TEST PROCEDURE

The transmitter output is connected to a spectrum analyzer the analyzer bandwidth is set to a value greater than the 20 dB bandwidth of the EUT.

RESULTS

Channel	Frequency (MHz)	Output Power (dBm)	Limit (dBm)	Margin (dB)
Low	2402	10.30	20.97	-10.67
Middle	2441	10.89	20.97	-10.08
High	2480	11.05	20.97	-9.92

OUTPUT POWER

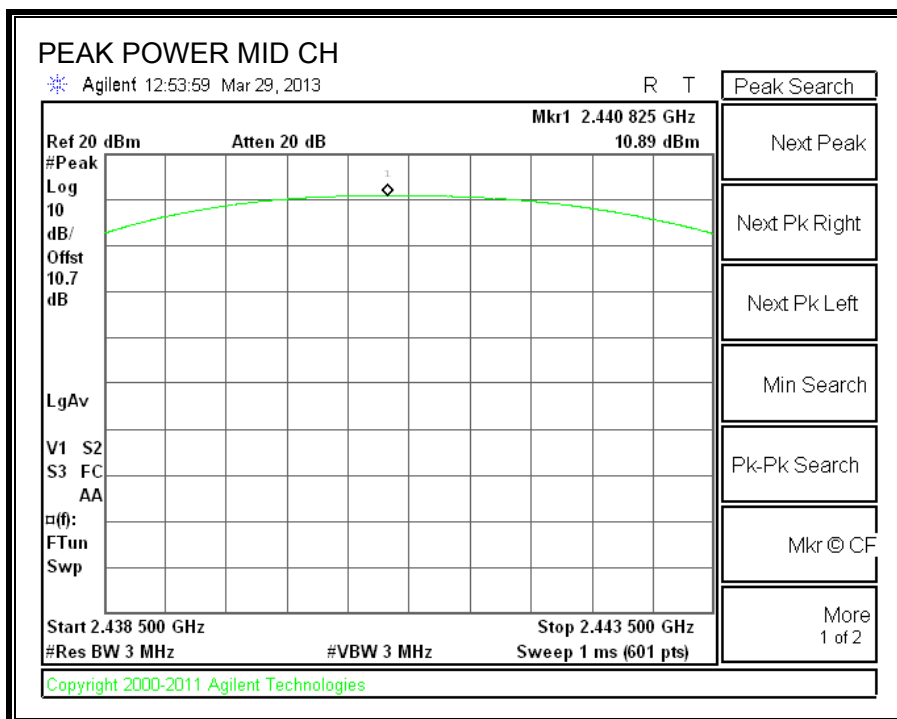
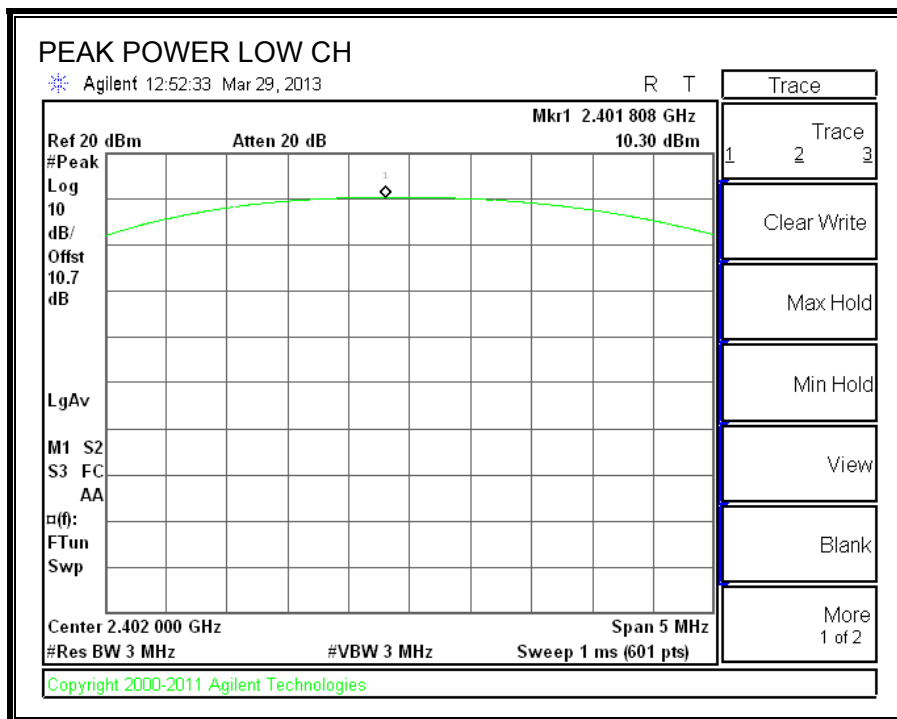

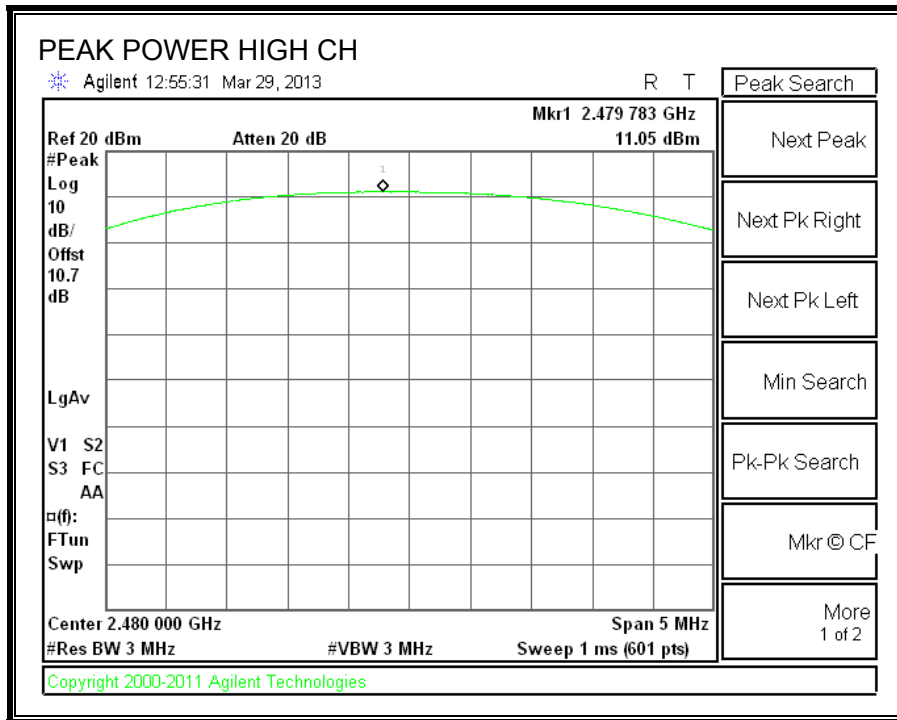

7.2.6. AVERAGE POWER

LIMIT

None; for reporting purposes only.

TEST PROCEDURE

The transmitter output is connected to a power meter.

RESULTS

The cable assembly insertion loss of 10.67 dB (including 10 dB pad and 0.67 dB cable) was entered as an offset in the power meter to allow for direct reading of power.

Channel	Frequency (MHz)	Average Power (dBm)
Low	2402	8.83
Middle	2441	8.79
High	2480	8.97

7.2.7. CONDUCTED SPURIOUS EMISSIONS

LIMITS

FCC §15.247 (d)

IC RSS-210 A8.5

Limit = -20 dBc

TEST PROCEDURE

The transmitter output is connected to a spectrum analyzer. The resolution bandwidth is set to 100 kHz. The video bandwidth is set to 300 kHz.

The spectrum from 30 MHz to 26 GHz is investigated with the transmitter set to the lowest, middle, and highest channels.

The band edges at 2.4 and 2.4835 GHz are investigated with the transmitter set to the normal hopping mode.

RESULTS

SPURIOUS EMISSIONS, LOW CHANNEL

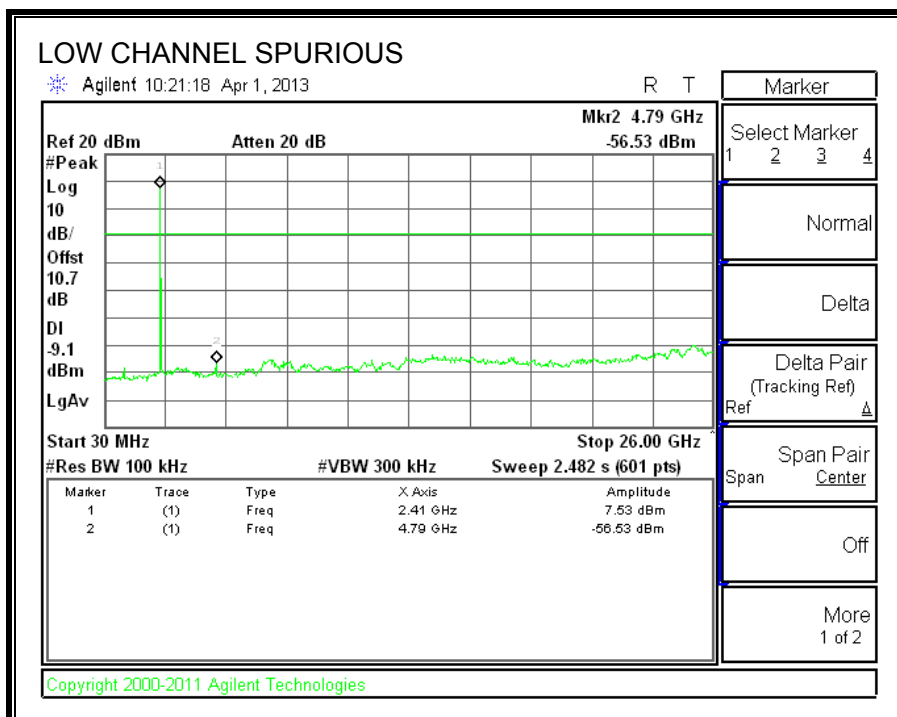
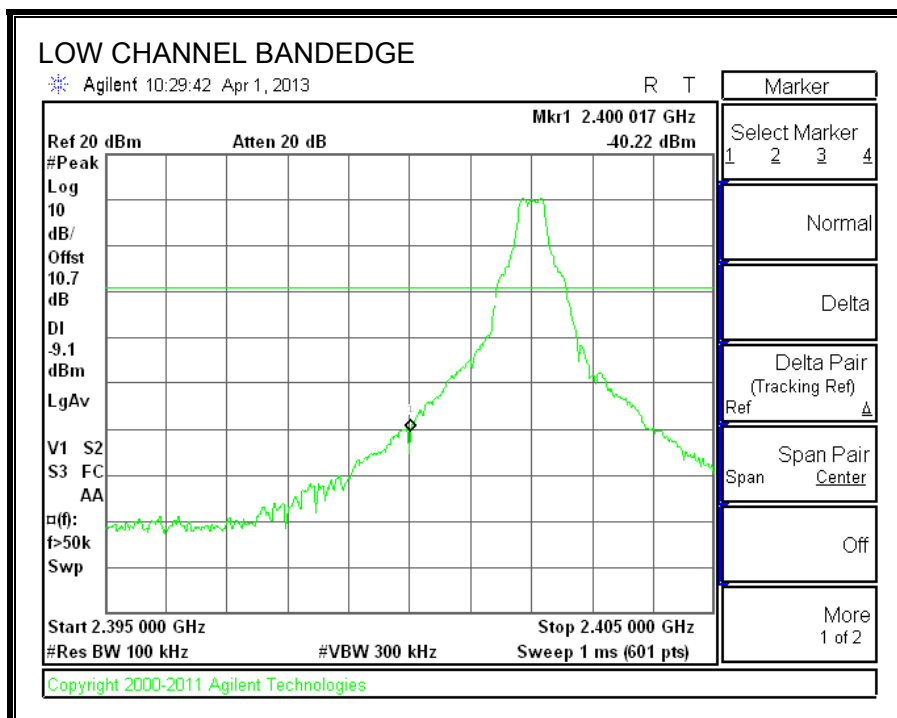

SPURIOUS EMISSIONS, MID CHANNEL

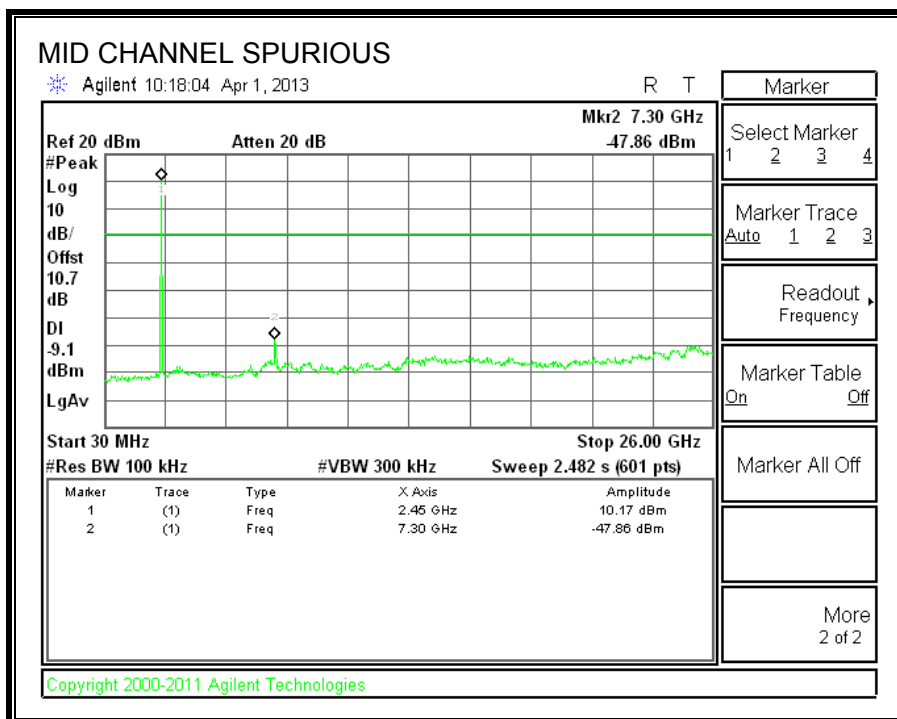
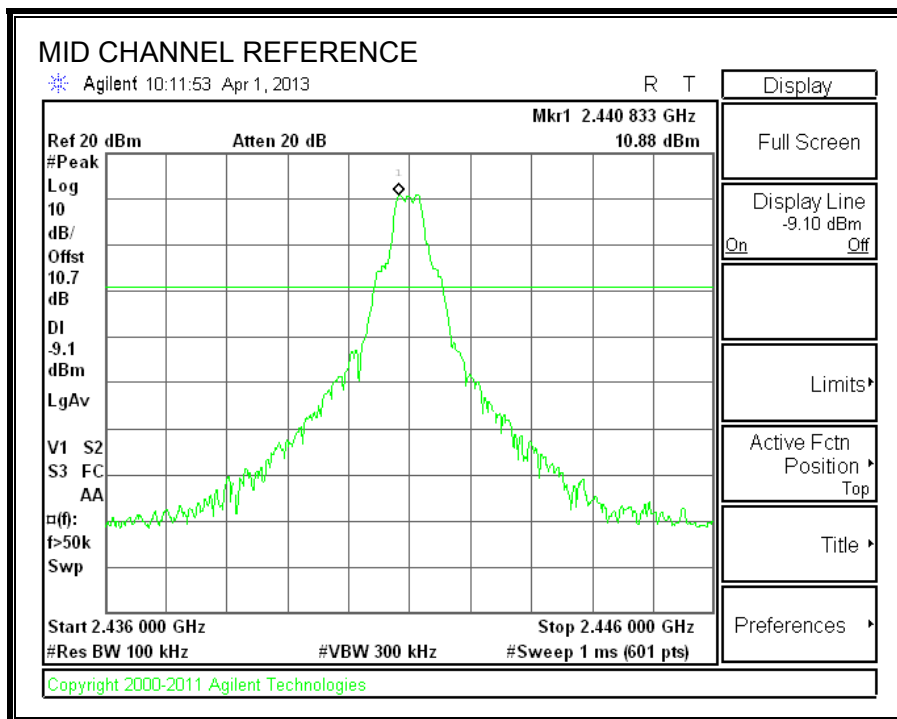

SPURIOUS EMISSIONS, HIGH CHANNEL

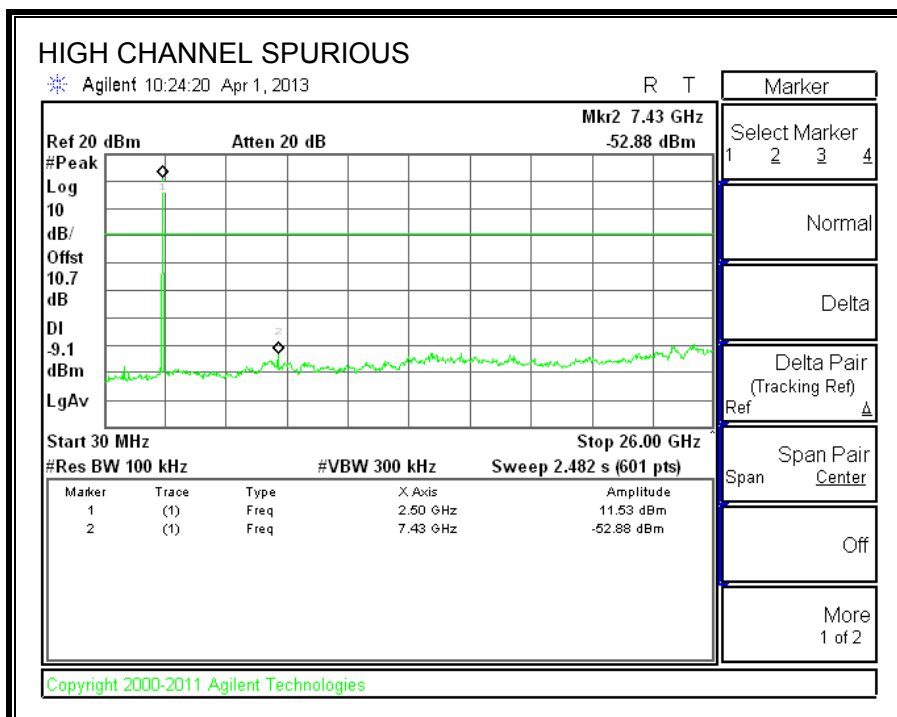
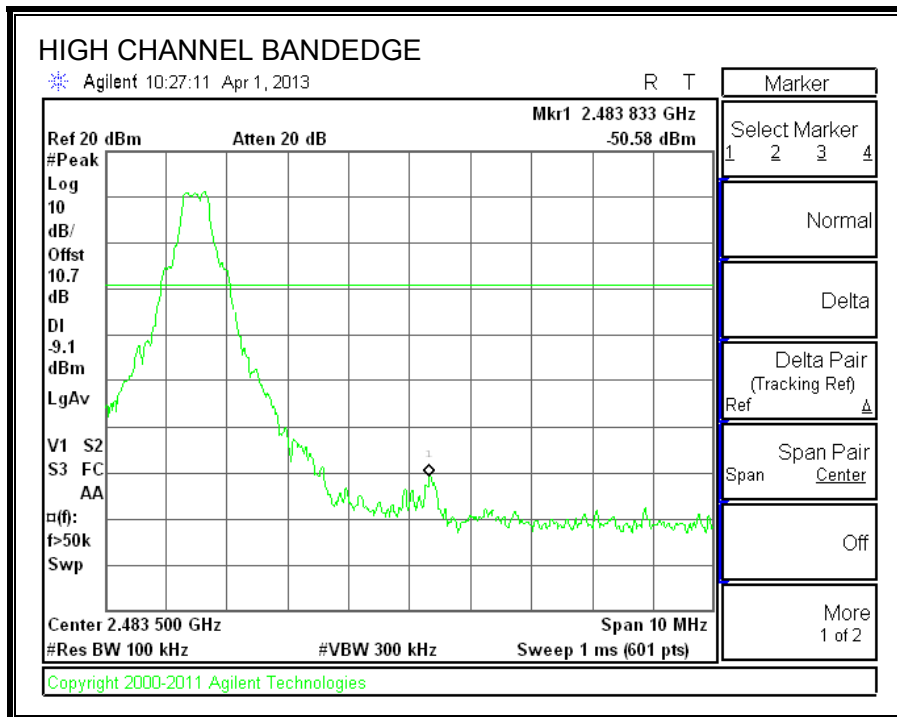

SPURIOUS BANDEDGE EMISSIONS WITH HOPPING ON

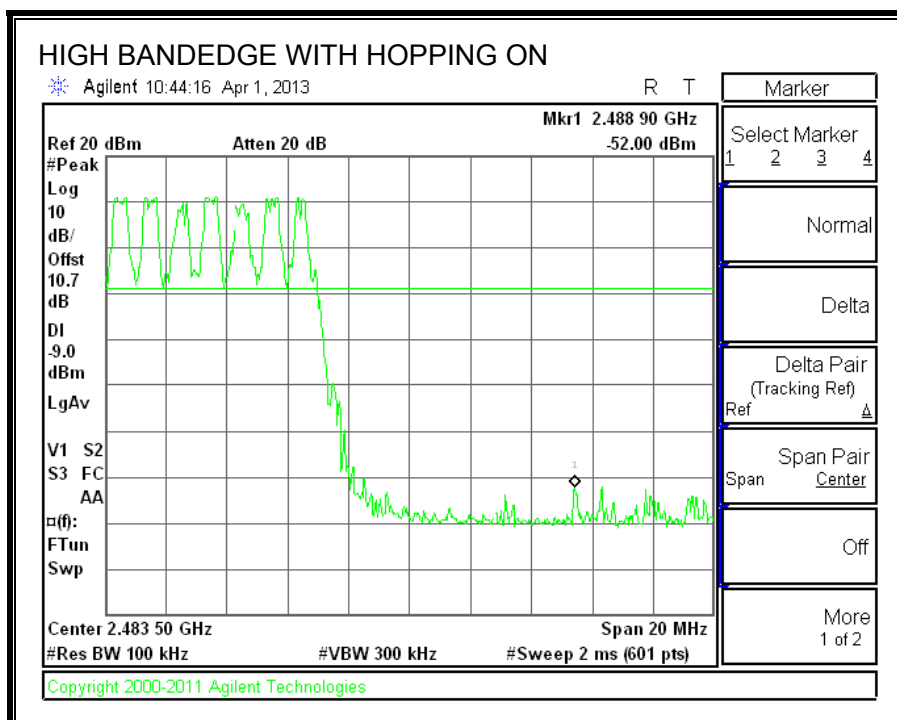
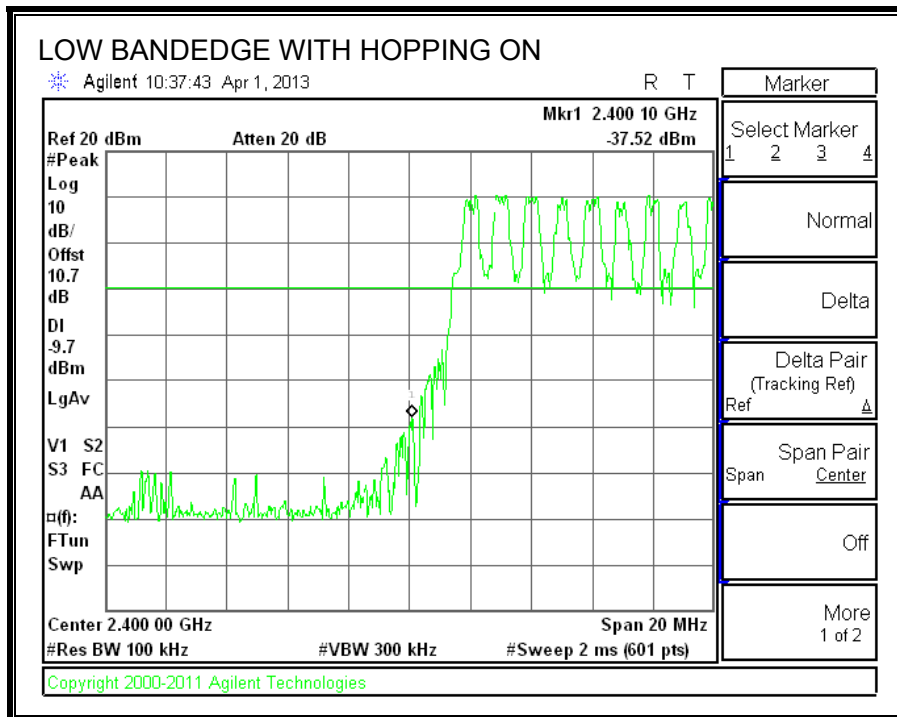

7.3. ENHANCED DATA RATE 8PSK MODULATION

7.3.1. 20 dB AND 99% BANDWIDTH

LIMIT

None; for reporting purposes only.

TEST PROCEDURE

The transmitter output is connected to a spectrum analyzer. The RBW is set to $\geq 1\%$ of the 20 dB bandwidth. The VBW is set to \geq RBW. The sweep time is coupled.

RESULTS

Channel	Frequency (MHz)	20 dB Bandwidth (MHz)	99% Bandwidth (MHz)
Low	2402	1.146	1.0670
Middle	2441	1.118	1.0626
High	2480	1.119	1.0685

20 dB BANDWIDTH

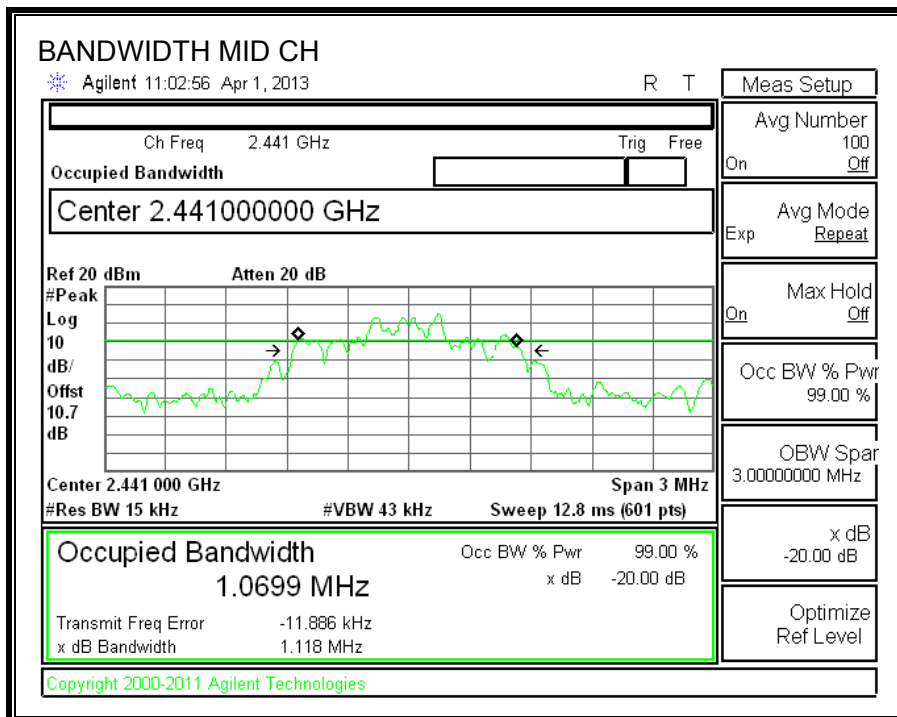
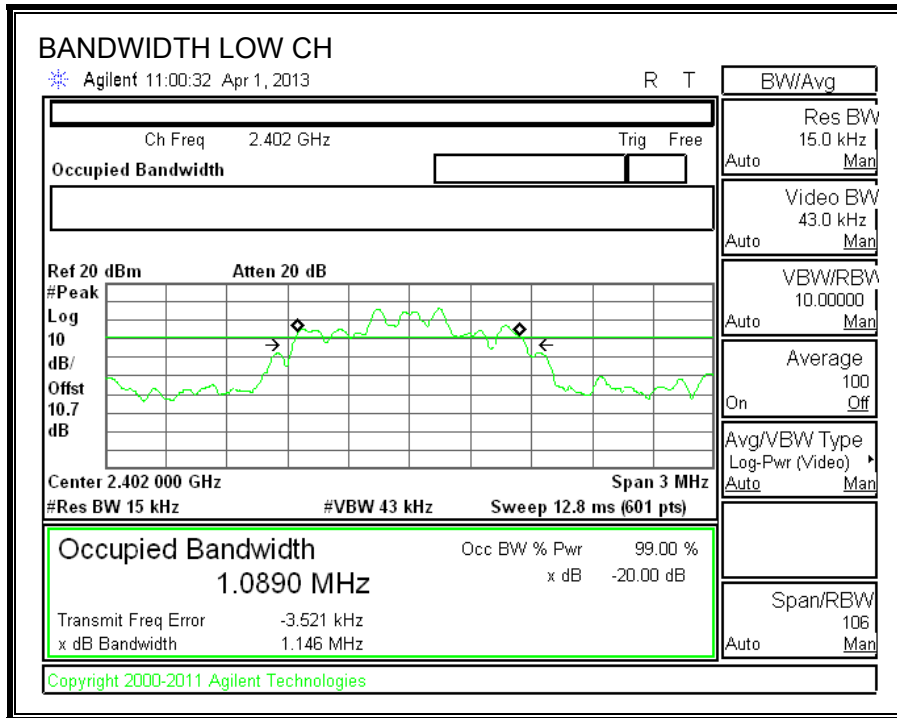

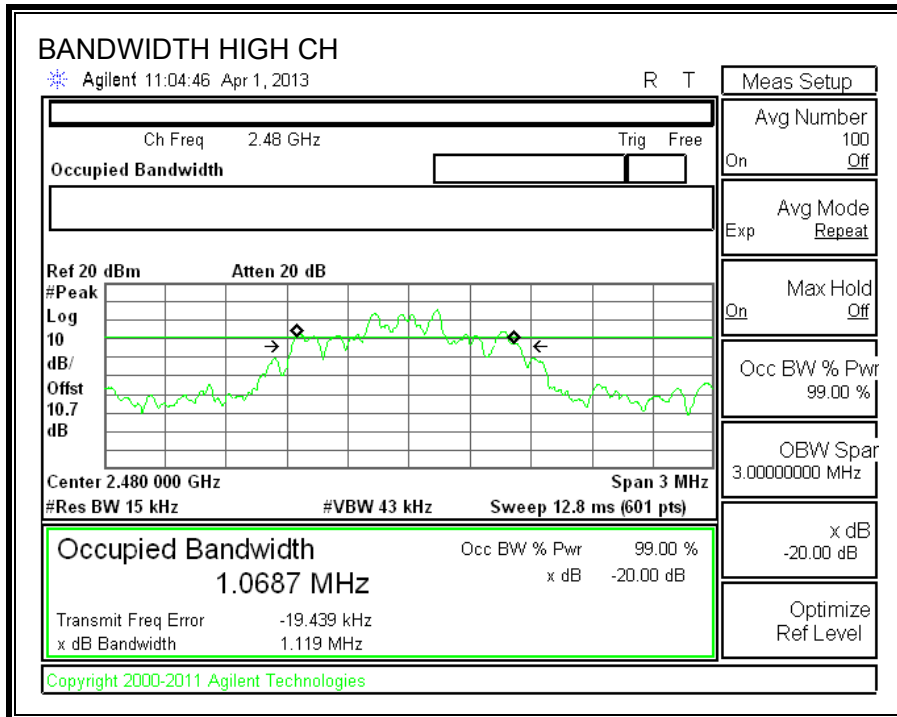

99% BANDWIDTH

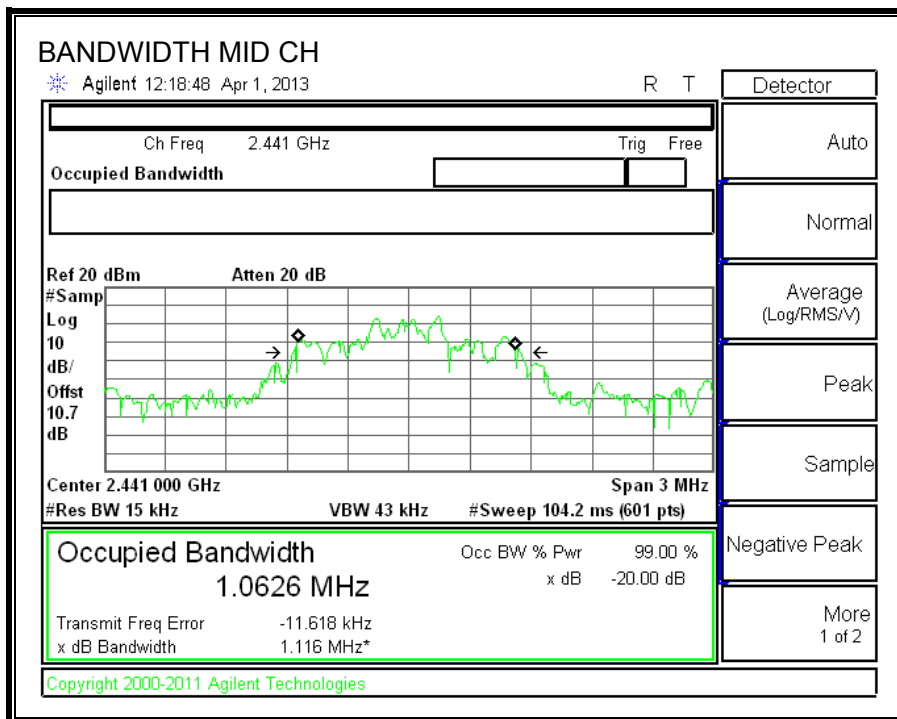
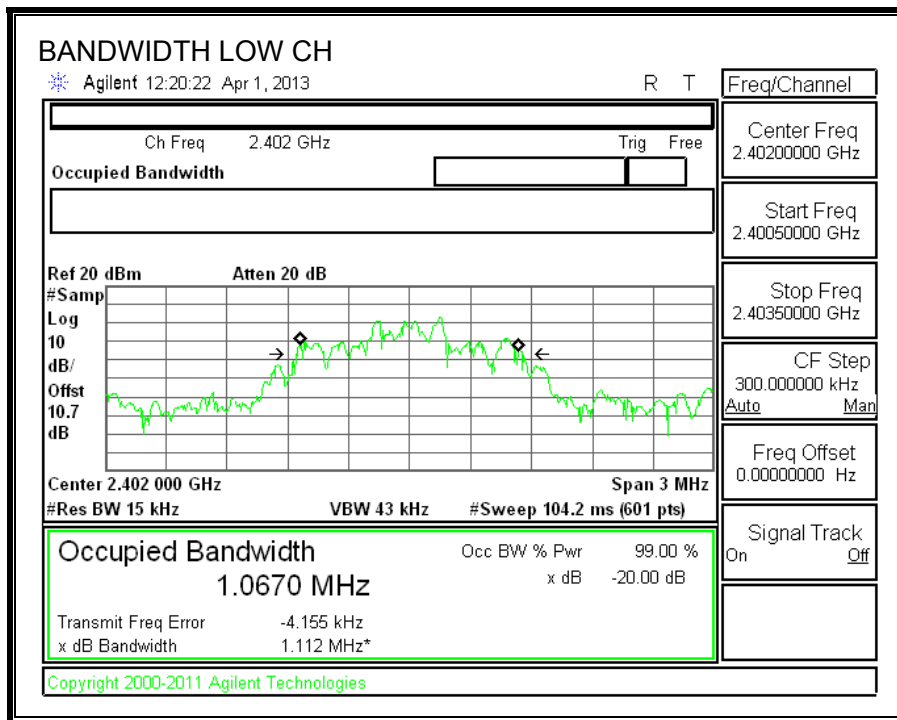

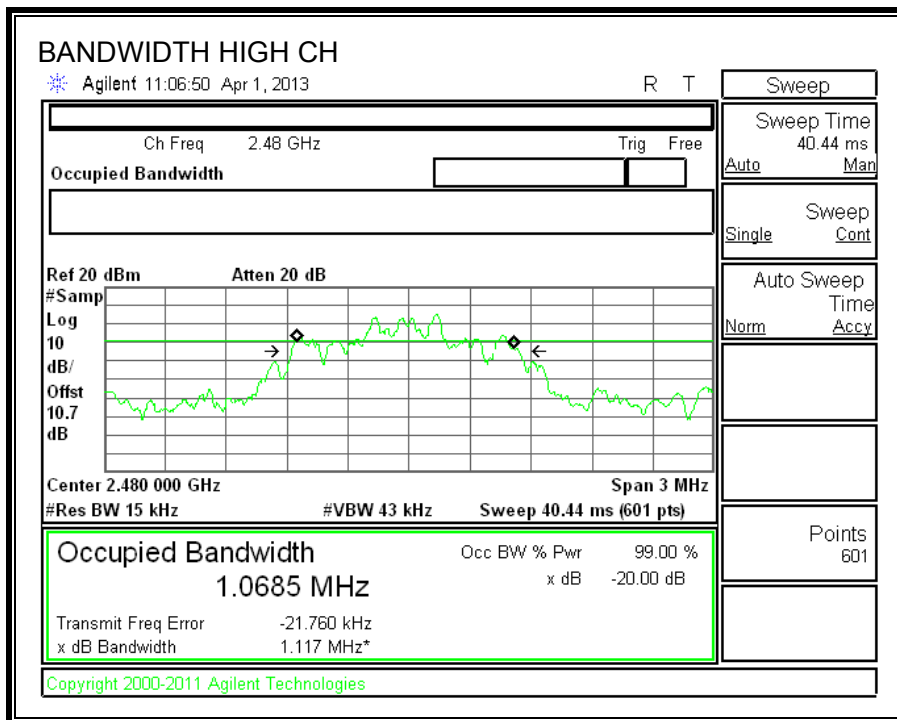

7.3.2. HOPPING FREQUENCY SEPARATION

LIMIT

FCC §15.247 (a) (1)

IC RSS-210 A8.1 (b)

Frequency hopping systems shall have hopping channel carrier frequencies separated by a minimum of 25 kHz or the 20 dB bandwidth of the hoping channel, whichever is greater.

Alternatively, frequency hopping systems operating in the 2400-2483.5 MHz band may have hopping channel carrier frequencies that are separated by 25 kHz or two-thirds of the 20 dB bandwidth of the hopping channel, whichever is greater, provided the systems operate with an output power no greater than 125 mW.

TEST PROCEDURE

The transmitter output is connected to a spectrum analyzer. The RBW is set to 300 kHz and the VBW is set to 300 kHz. The sweep time is coupled.

RESULTS

HOPPING FREQUENCY SEPARATION

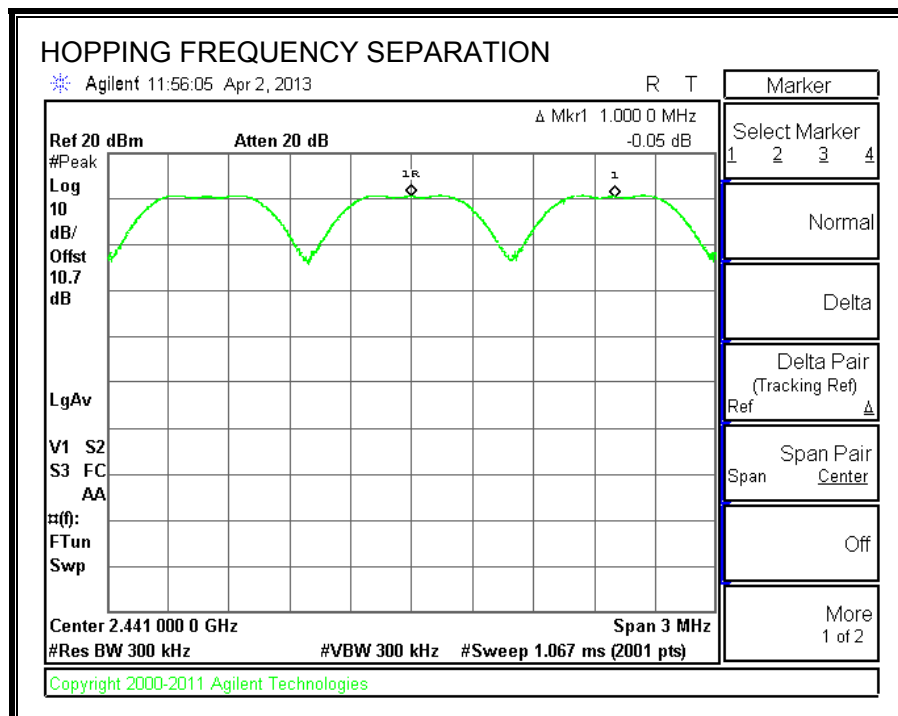

7.3.3. NUMBER OF HOPPING CHANNELS

LIMIT

FCC §15.247 (a) (1) (iii)

IC RSS-210 A8.1 (d)

Frequency hopping systems in the 2400 – 2483.5 MHz band shall use at least 15 non-overlapping channels.

TEST PROCEDURE

The transmitter output is connected to a spectrum analyzer. The span is set to cover the entire authorized band, in either a single sweep or in multiple contiguous sweeps. The RBW is set to a maximum of 1 % of the span. The analyzer is set to Max Hold.

RESULTS

The EUT is capable of adaptive frequency hopping.

Number of channels for normal hopping mode = 79

Number of channels for AFH mode, as declared by the client = 20

NUMBER OF HOPPING CHANNELS

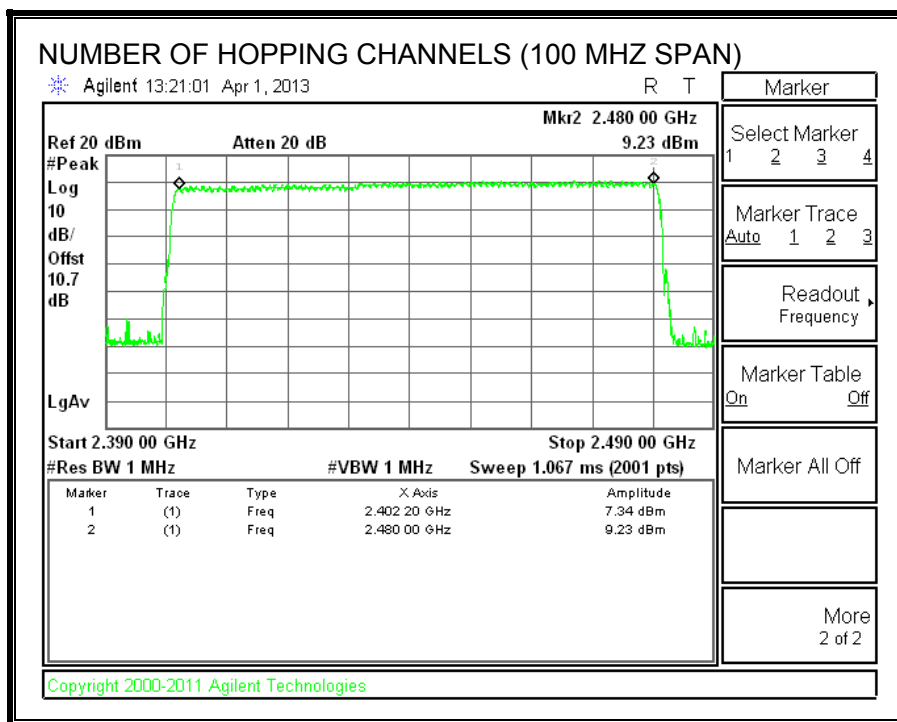

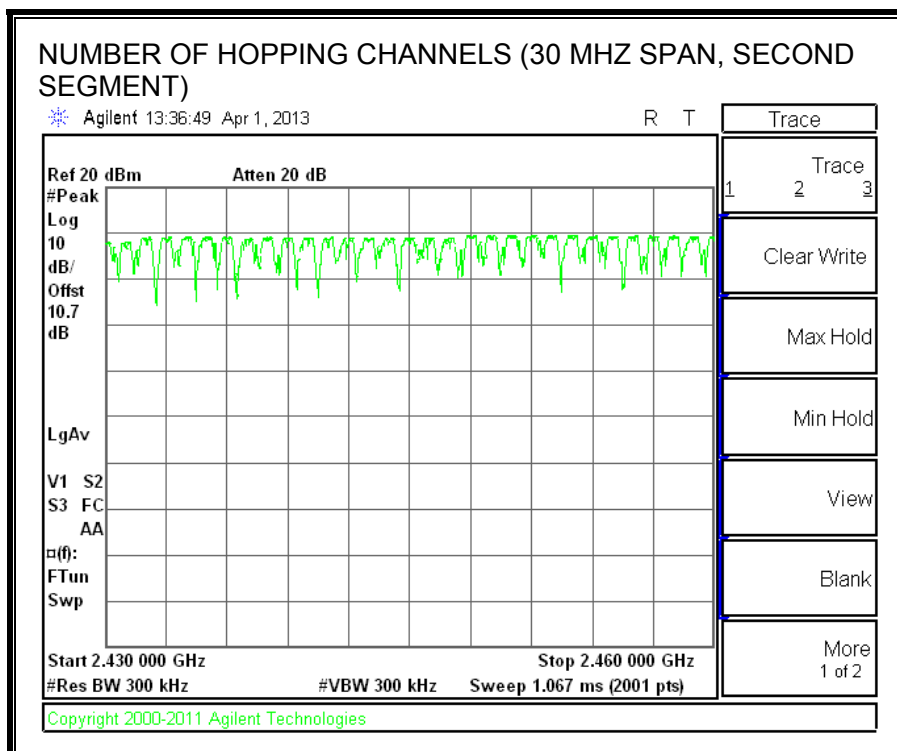
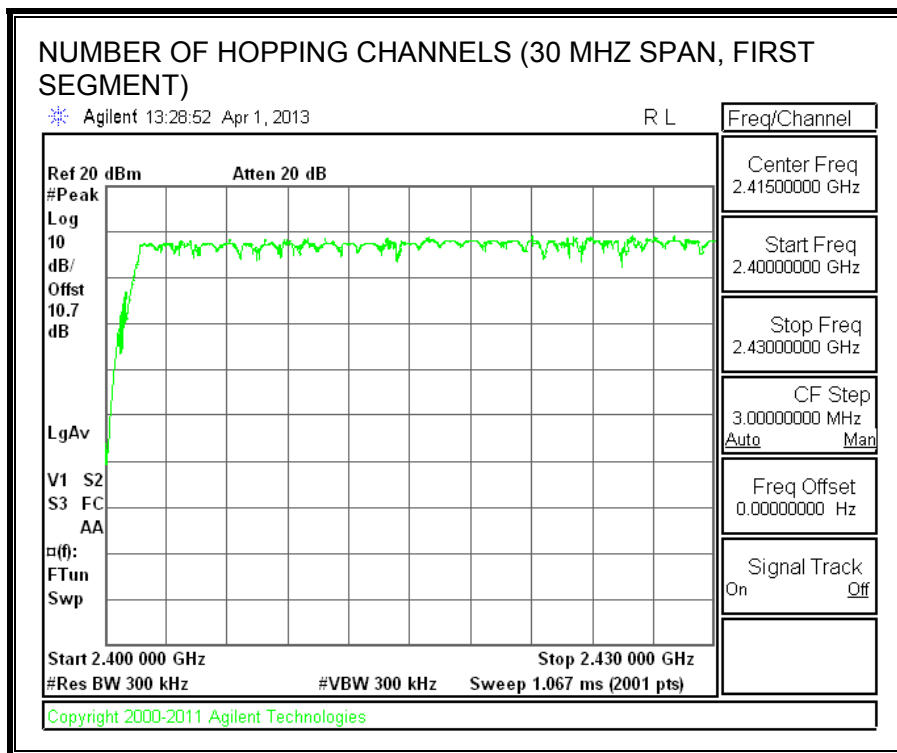

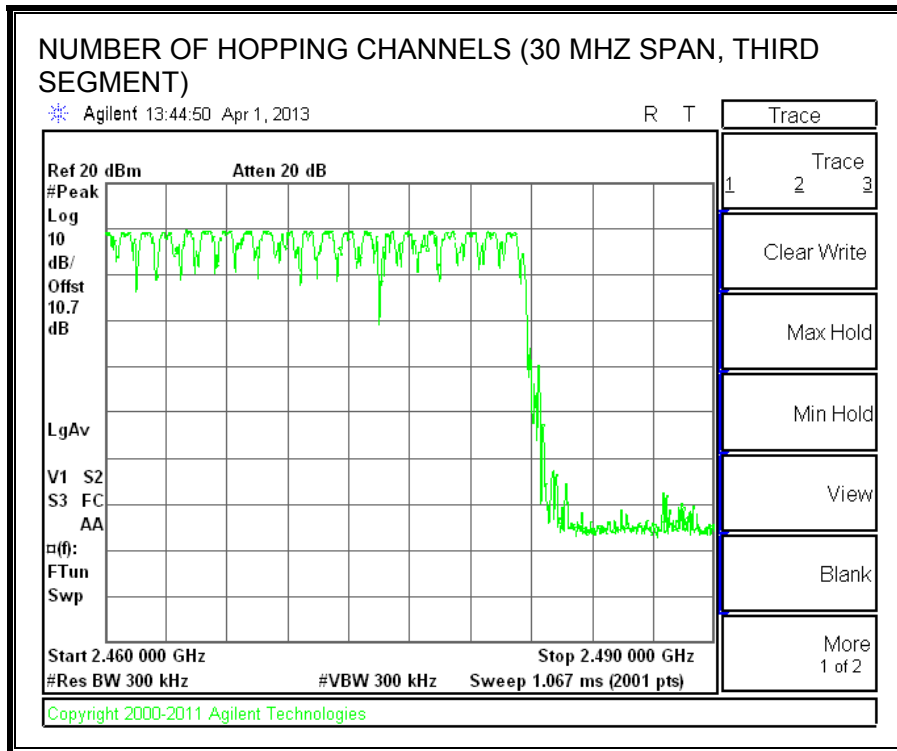

7.3.4. AVERAGE TIME OF OCCUPANCY

LIMIT

FCC §15.247 (a) (1) (iii)

IC RSS-210 A8.1 (d)

The average time of occupancy on any channel shall not be greater than 0.4 seconds within a period of 0.4 seconds multiplied by the number of hopping channels employed.

TEST PROCEDURE

The transmitter output is connected to a spectrum analyzer. The span is set to 0 Hz, centered on a single, selected hopping channel. The width of a single pulse is measured in a fast scan. The number of pulses is measured in a 3.16 second scan, to enable resolution of each occurrence.

The average time of occupancy in the specified 31.6 second period (79 channels * 0.4 s) is equal to $10 * (\# \text{ of pulses in } 3.16 \text{ s}) * \text{ pulse width}$.

RESULTS

8PSK (EDR) Mode

DH Packet	Pulse Width (msec)	Number of Pulses in 3.16 seconds	Average Time of (sec)	Limit (sec)	Margin (sec)
DH1	0.4144	32	0.133	0.4	-0.267
DH3	1.658	16	0.265	0.4	-0.135
DH5	2.923	12	0.351	0.4	-0.049

Note: for AFH (8PSK) mode, please refer to the results of AFH (GFSK) mode; the channel selection and hopping rate are the same for both EDR and Basic Rate operation, data for Basic Rate on page 21 demonstrates compliance with channel occupancy when AFH is employed.

PULSE WIDTH - DH1

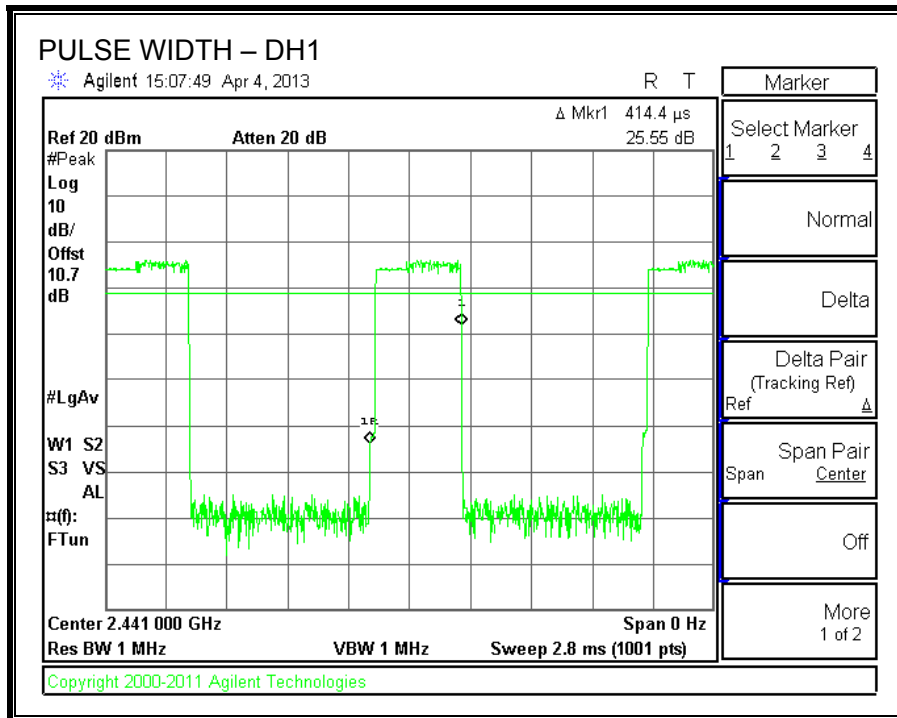

NUMBER OF PULSES IN 3.16 SECOND OBSERVATION PERIOD - DH1

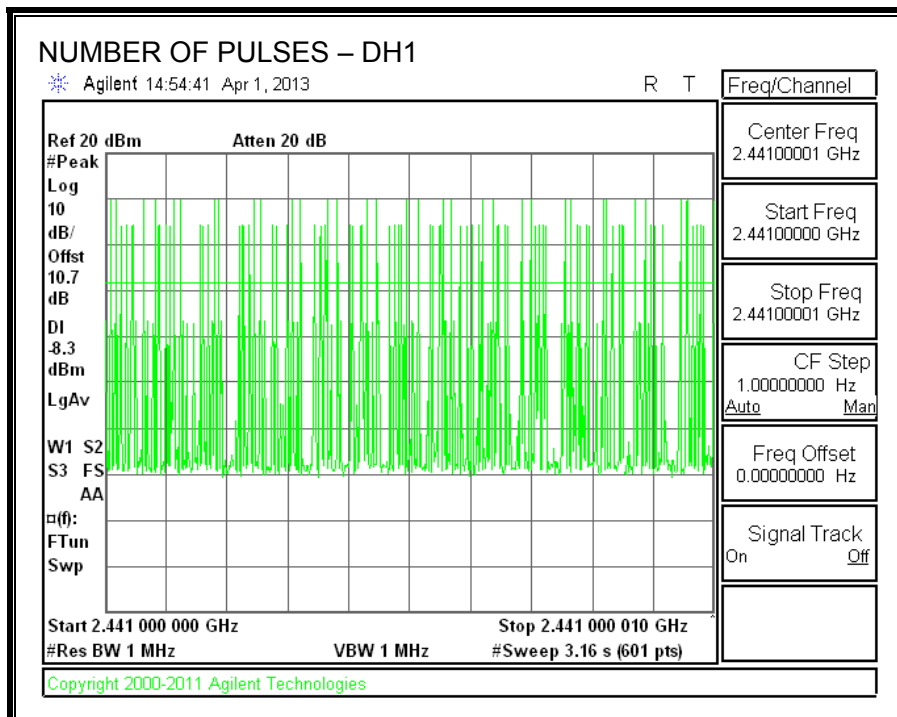

PULSE WIDTH – DH3

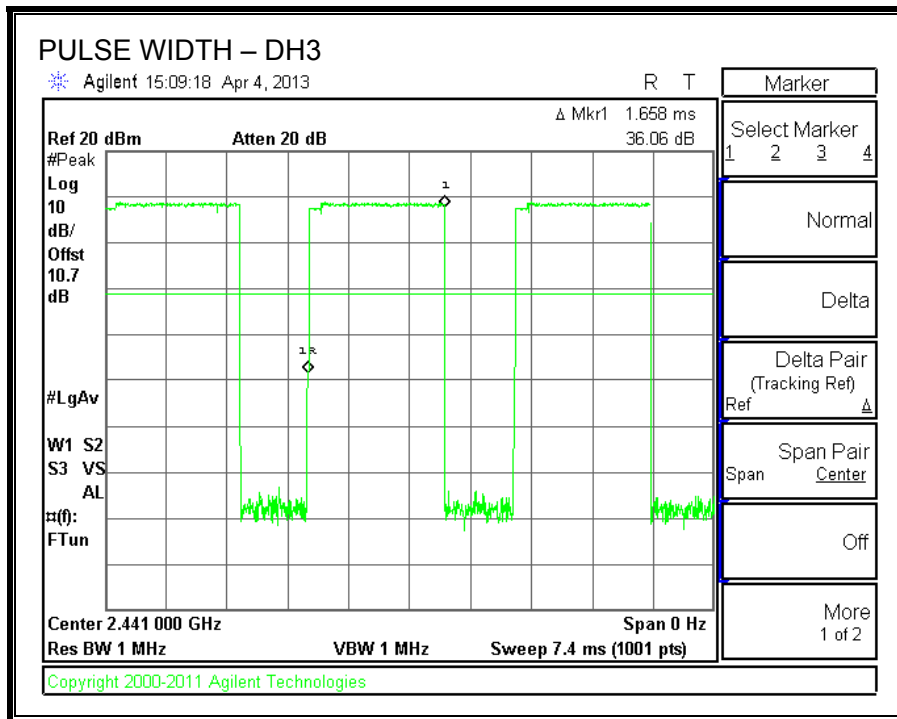

NUMBER OF PULSES IN 3.16 SECOND OBSERVATION PERIOD – DH3

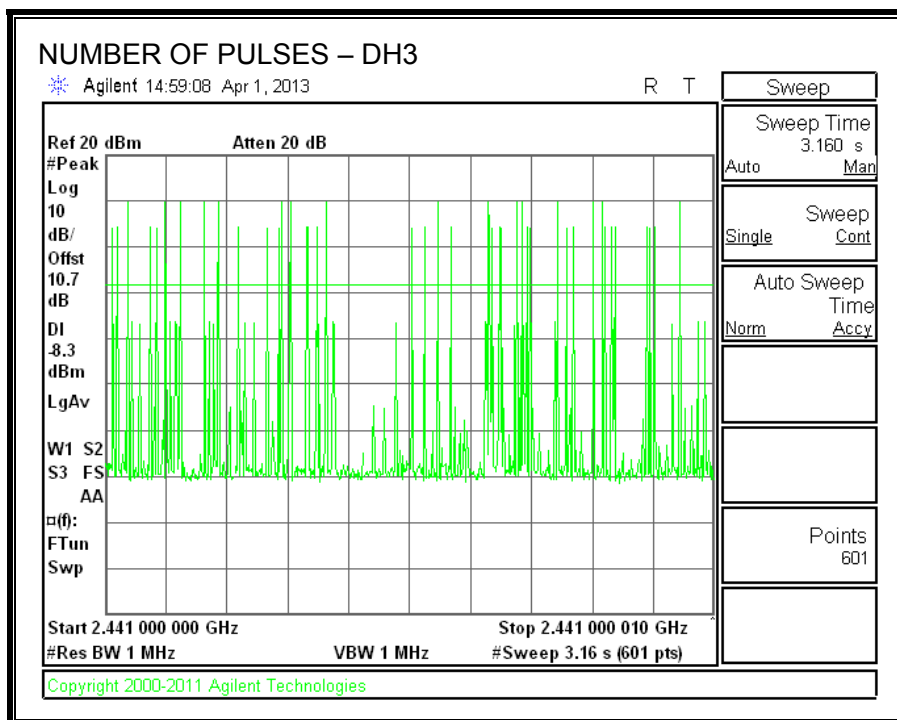

PULSE WIDTH – DH5

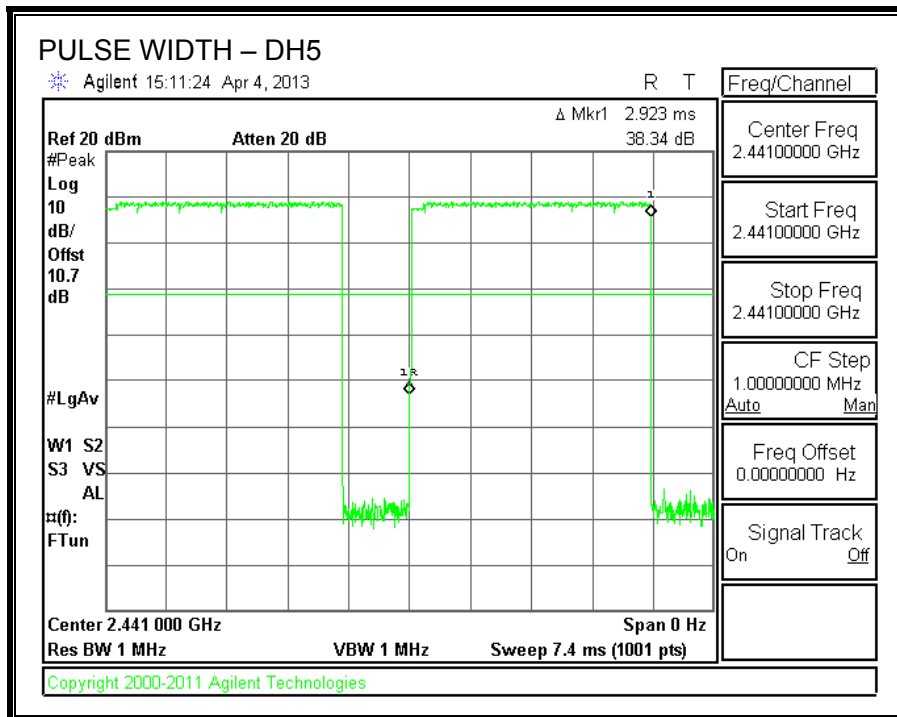

NUMBER OF PULSES IN 3.16 SECOND OBSERVATION PERIOD – DH5

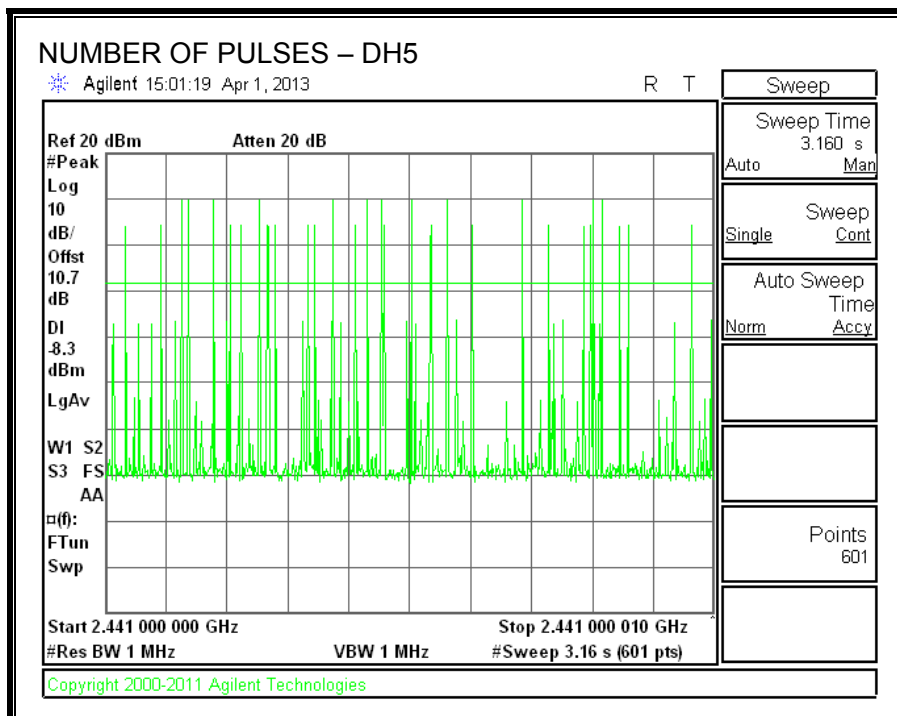

7.3.5. OUTPUT POWER

LIMIT

§15.247 (b) (1)

RSS-210 Issue 7 Clause A8.4

The maximum antenna gain is less than 6 dBi, therefore the limit is 20.97 dBm.

TEST PROCEDURE

The transmitter output is connected to a spectrum analyzer the analyzer bandwidth is set to a value greater than the 20 dB bandwidth of the EUT.

RESULTS

Channel	Frequency (MHz)	Output Power (dBm)	Limit (dBm)	Margin (dB)
Low	2402	8.90	20.97	-12.07
Middle	2441	10.27	20.97	-10.70
High	2480	10.72	20.97	-10.25

OUTPUT POWER

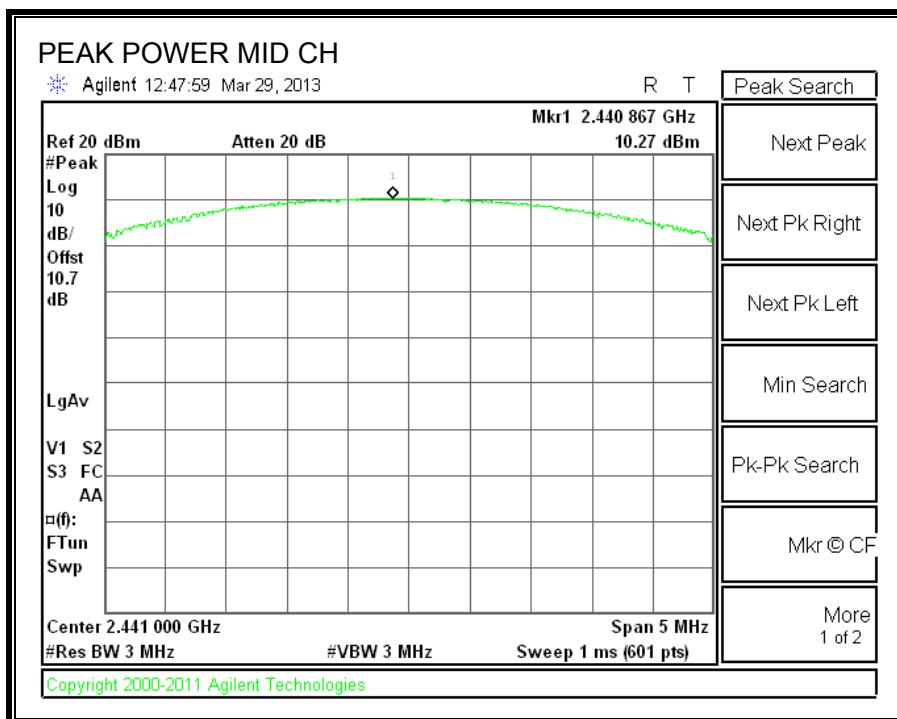
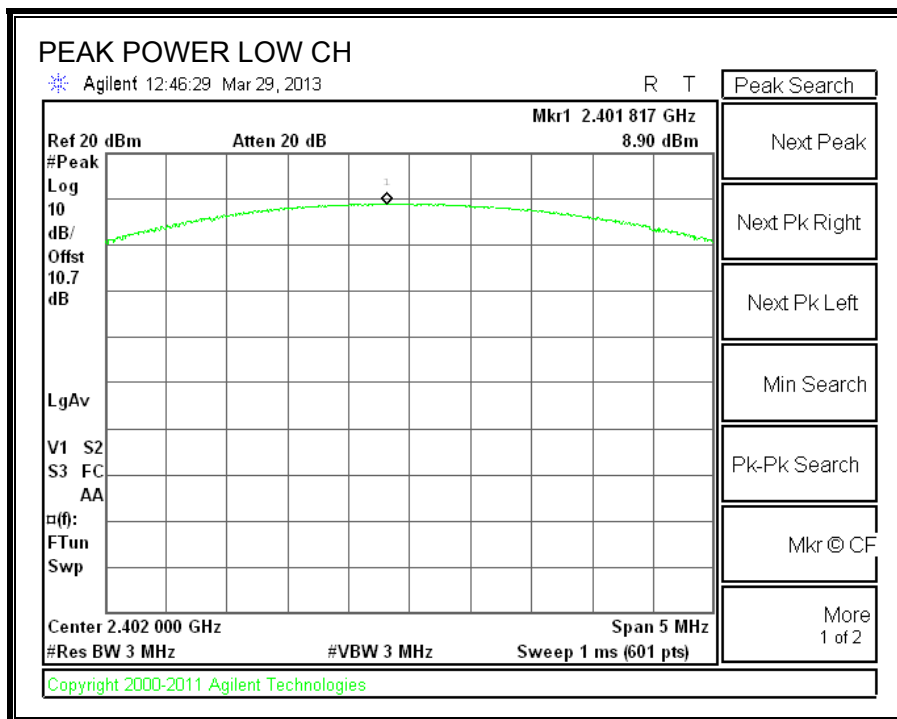

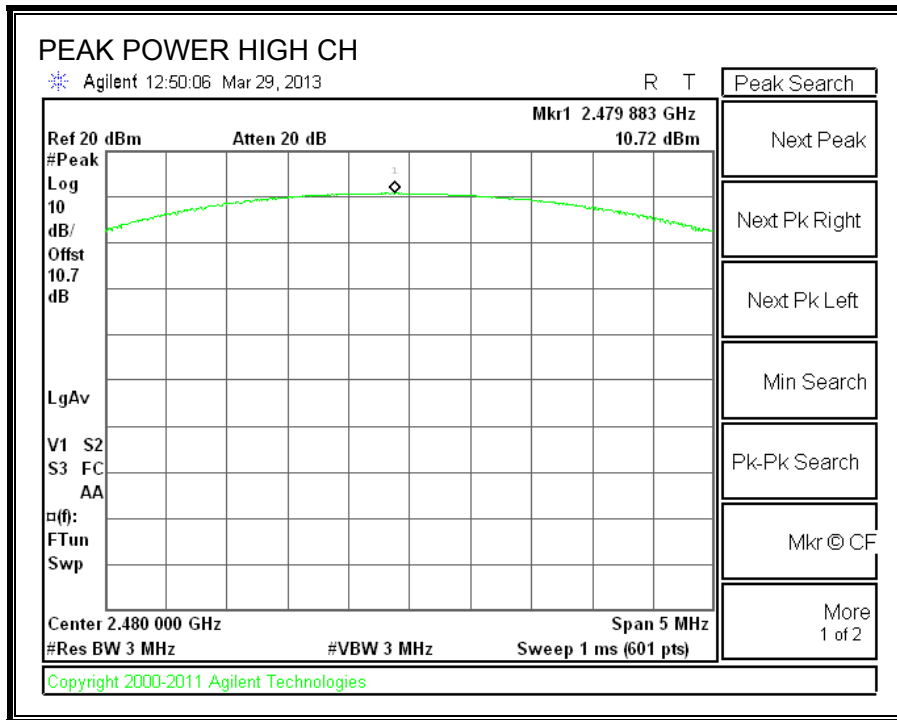

7.3.6. AVERAGE POWER

LIMIT

None; for reporting purposes only.

TEST PROCEDURE

The transmitter output is connected to a power meter.

RESULTS

The cable assembly insertion loss of 10.7 dB (including 10 dB pad and 0.7 dB cable) was entered as an offset in the power meter to allow for direct reading of power.

Channel	Frequency (MHz)	Average Power (dBm)
Low	2402	5.79
Middle	2441	6.05
High	2480	5.82

7.3.7. CONDUCTED SPURIOUS EMISSIONS

LIMITS

FCC §15.247 (d)

IC RSS-210 A8.5

Limit = -20 dBc

TEST PROCEDURE

The transmitter output is connected to a spectrum analyzer. The resolution bandwidth is set to 100 kHz. The video bandwidth is set to 300 kHz.

The spectrum from 30 MHz to 26 GHz is investigated with the transmitter set to the lowest, middle, and highest channels.

The band edges at 2.4 and 2.4835 GHz are investigated with the transmitter set to the normal hopping mode.

SPURIOUS EMISSIONS, LOW CHANNEL

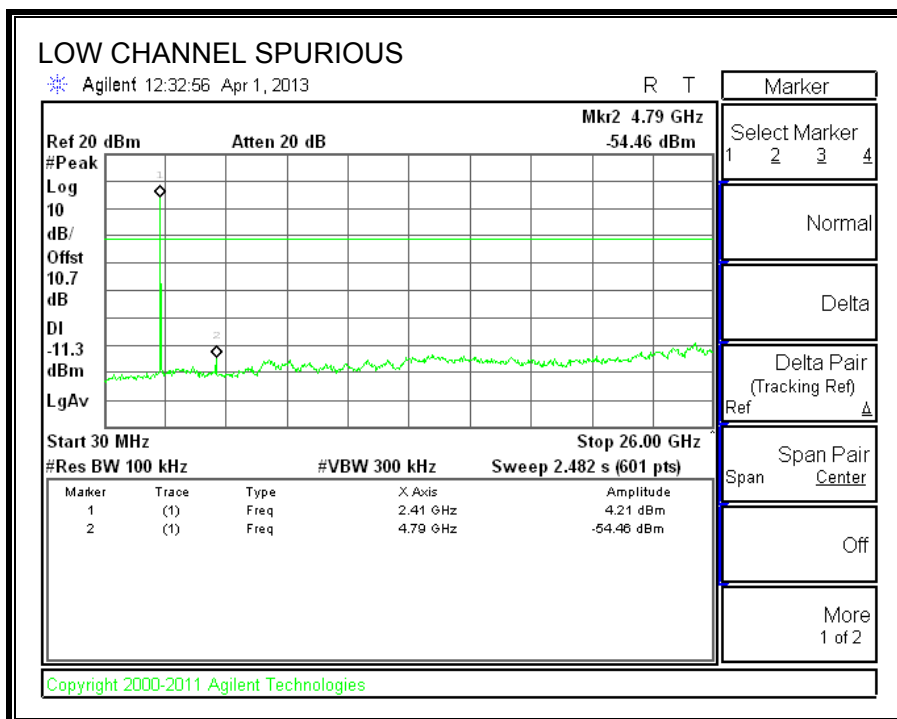
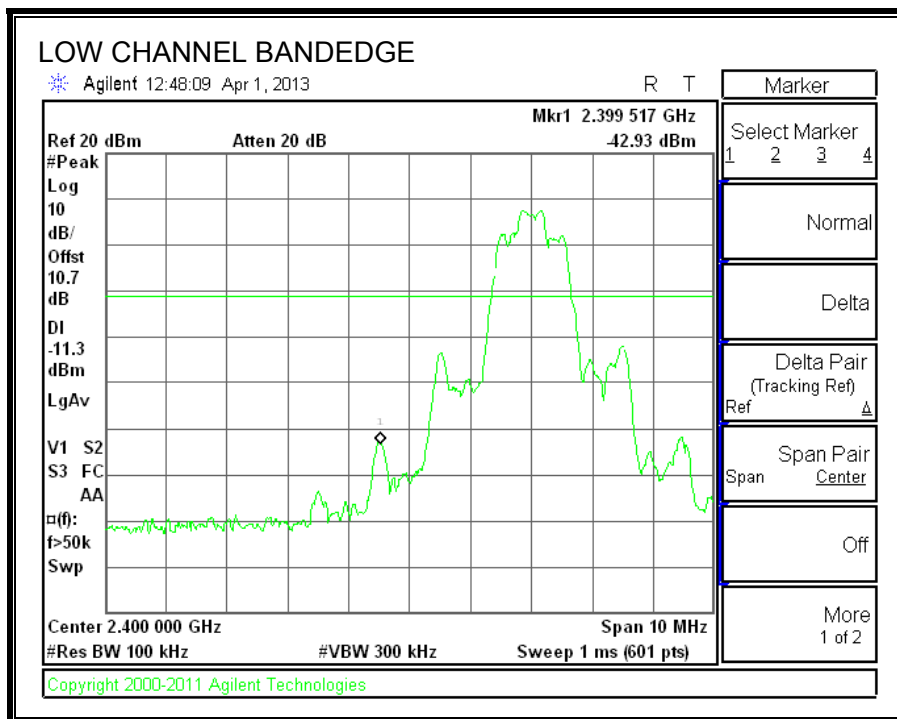

SPURIOUS EMISSIONS, MID CHANNEL

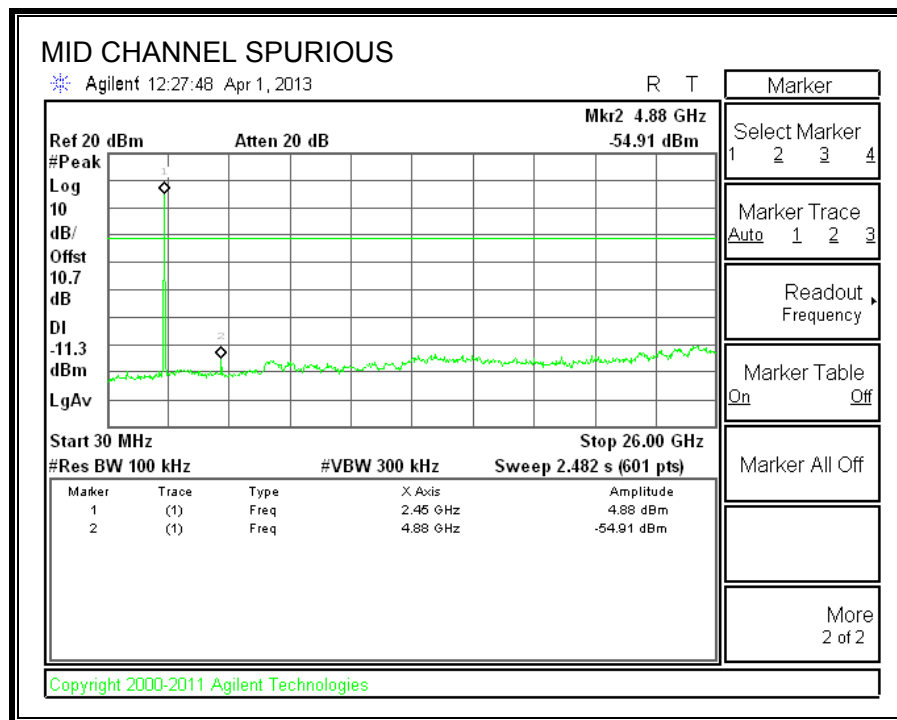
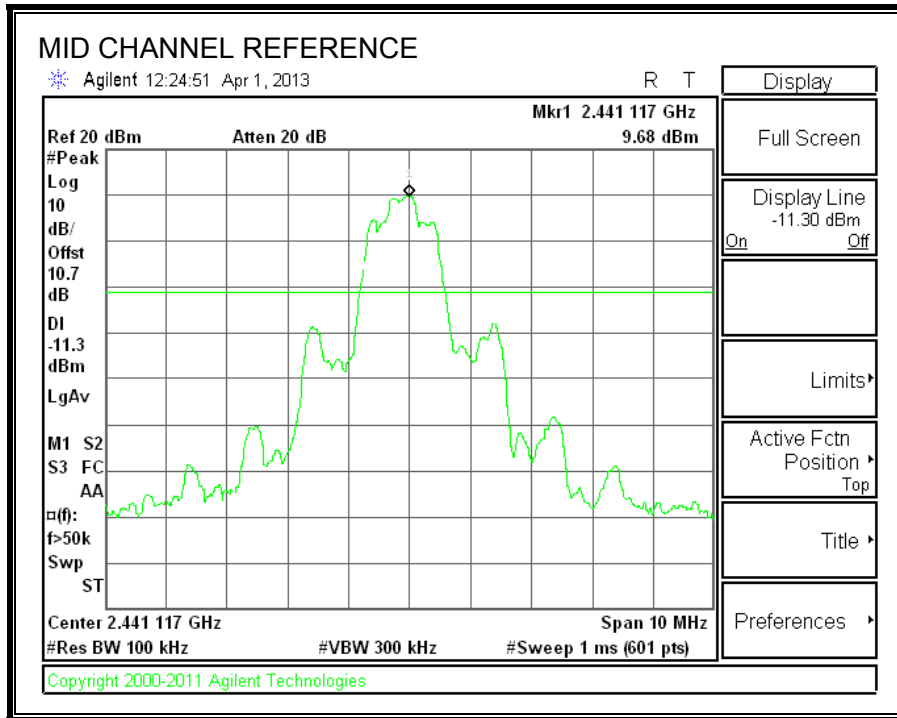

SPURIOUS EMISSIONS, HIGH CHANNEL

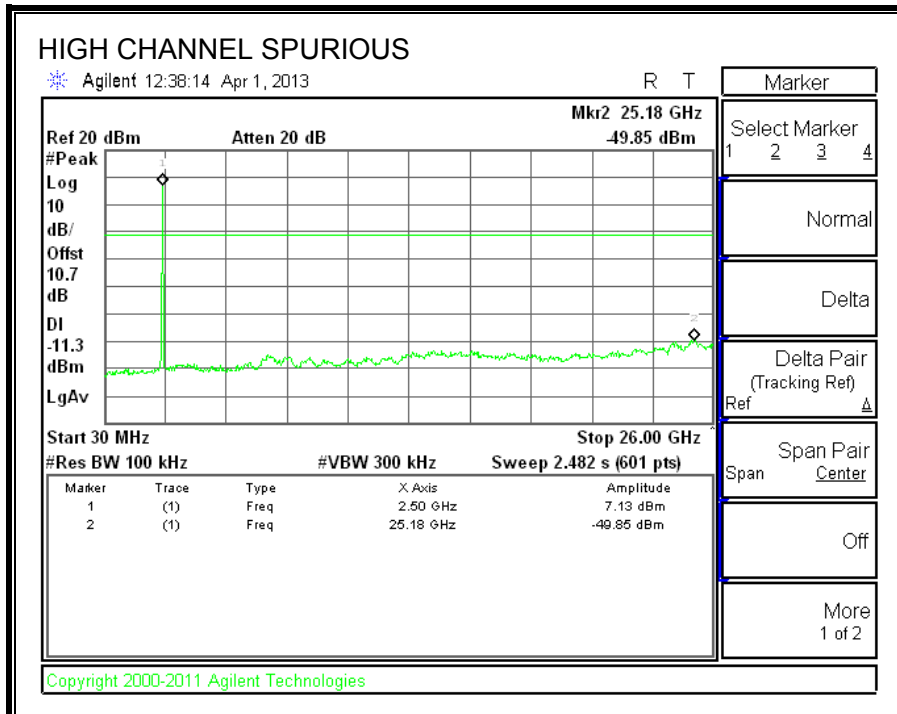
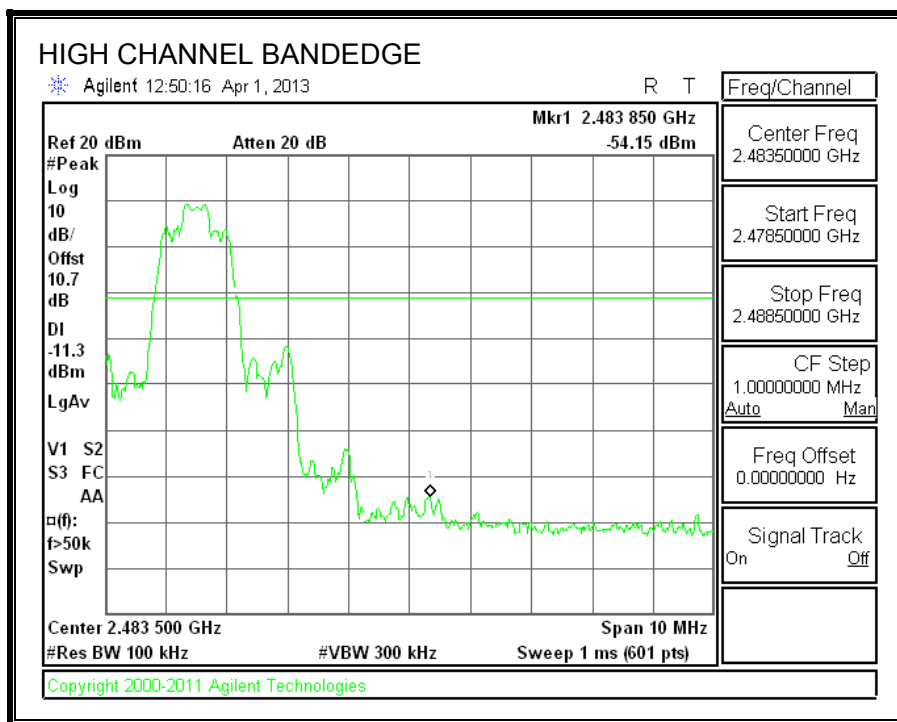

SPURIOUS BANDEDGE EMISSIONS WITH HOPPING ON

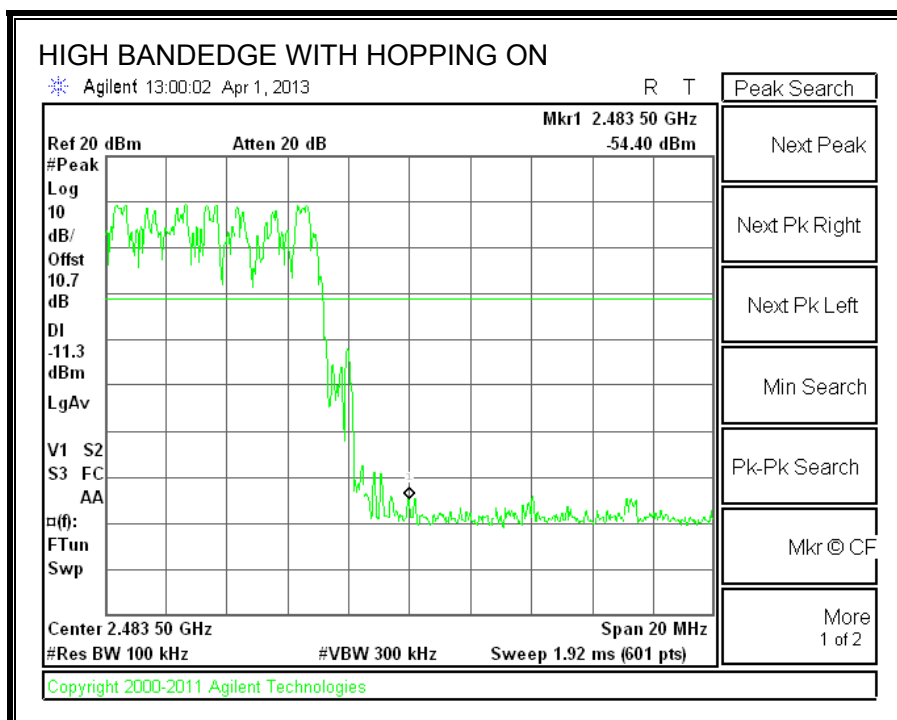
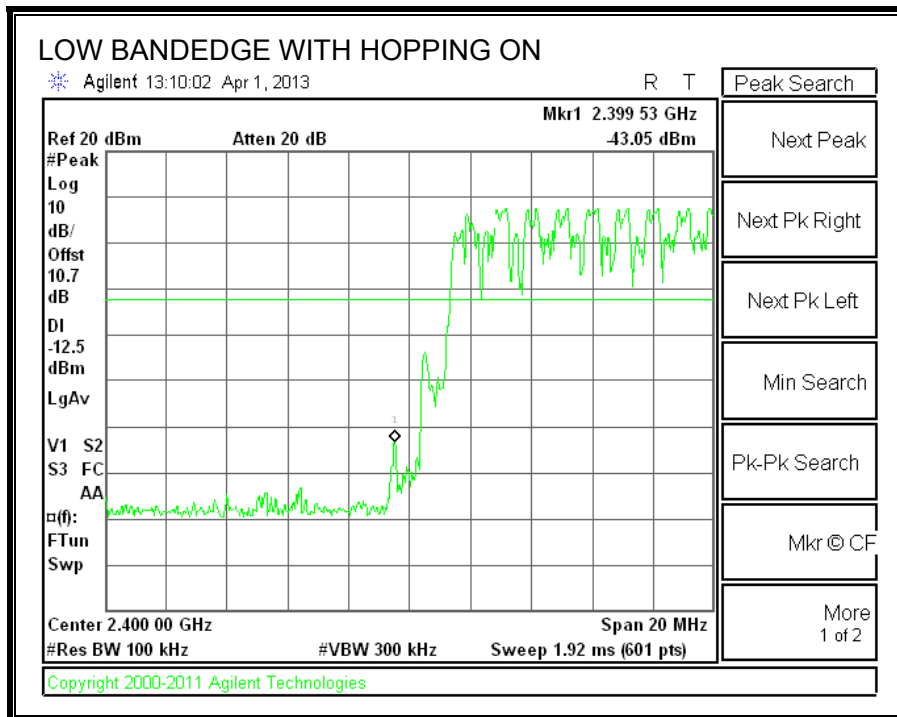

8. RADIATED TEST RESULTS

8.1. LIMITS AND PROCEDURE

LIMITS

FCC §15.205 and §15.209

IC RSS-210 Clause 2.6 (Transmitter)

IC RSS-GEN Clause 6 (Receiver)

Frequency Range (MHz)	Field Strength Limit (uV/m) at 3 m	Field Strength Limit (dBuV/m) at 3 m
30 - 88	100	40
88 - 216	150	43.5
216 - 960	200	46
Above 960	500	54

TEST PROCEDURE

The EUT is placed on a non-conducting table 80 cm above the ground plane. The antenna to EUT distance is 3 meters. The EUT is configured in accordance with ANSI C63.4. The EUT is set to transmit in a continuous mode.

For measurements below 1 GHz the resolution bandwidth is set to 100 kHz for peak detection measurements or 120 kHz for quasi-peak detection measurements. Peak detection is used unless otherwise noted as quasi-peak.

For measurements above 1 GHz the resolution bandwidth is set to 1 MHz, then the video bandwidth is set to 1 MHz for peak measurements and 10 Hz for average measurements.

The spectrum from 30 MHz to 26 GHz is investigated with the transmitter set to the lowest, middle, and highest channels in the 2.4 GHz band.

The frequency range of interest is monitored at a fixed antenna height and EUT azimuth. The EUT is rotated through 360 degrees to maximize emissions received. The antenna is scanned from 1 to 4 meters above the ground plane to further maximize the emission. Measurements are made with the antenna polarized in both the vertical and the horizontal positions.

8.2. TRANSMITTER ABOVE 1 GHZ

8.2.1. BASIC DATA RATE GFSK MODULATION

RESTRICTED BANDEDGE (LOW CHANNEL, HORIZONTAL)

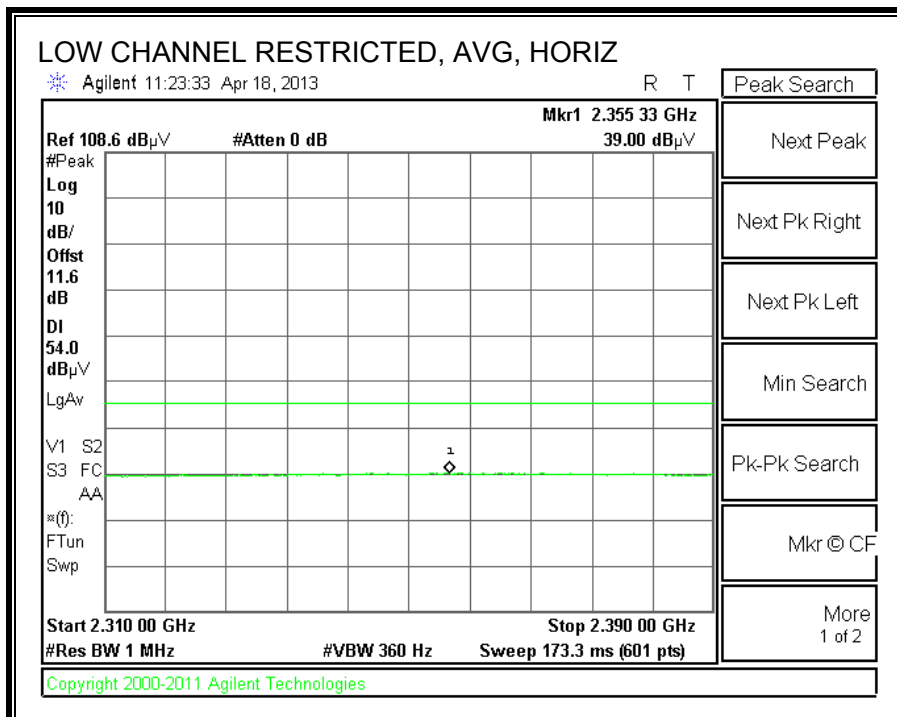
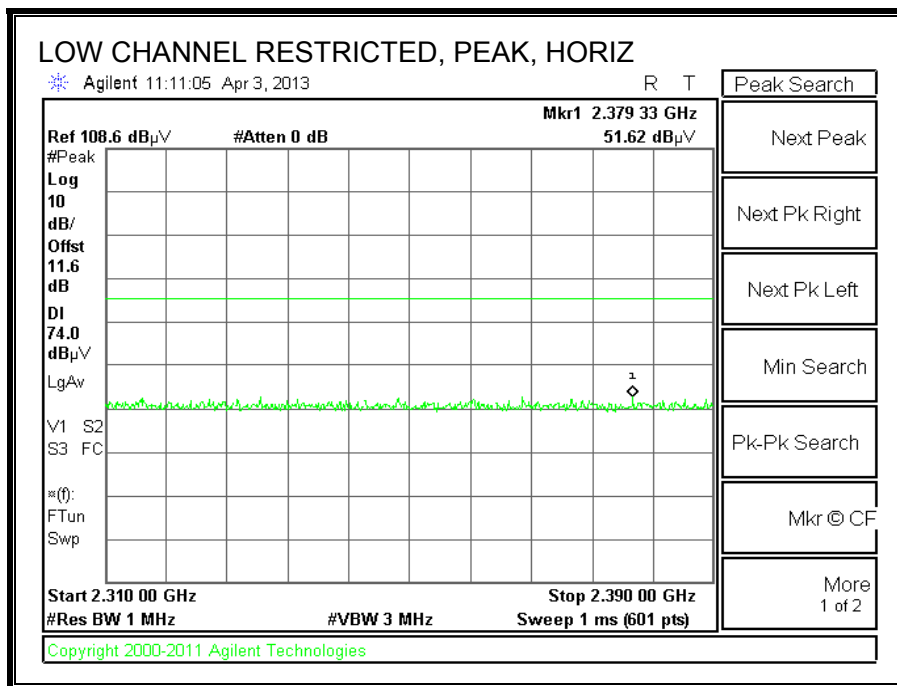

RESTRICTED BANDEDGE (LOW CHANNEL, VERTICAL)

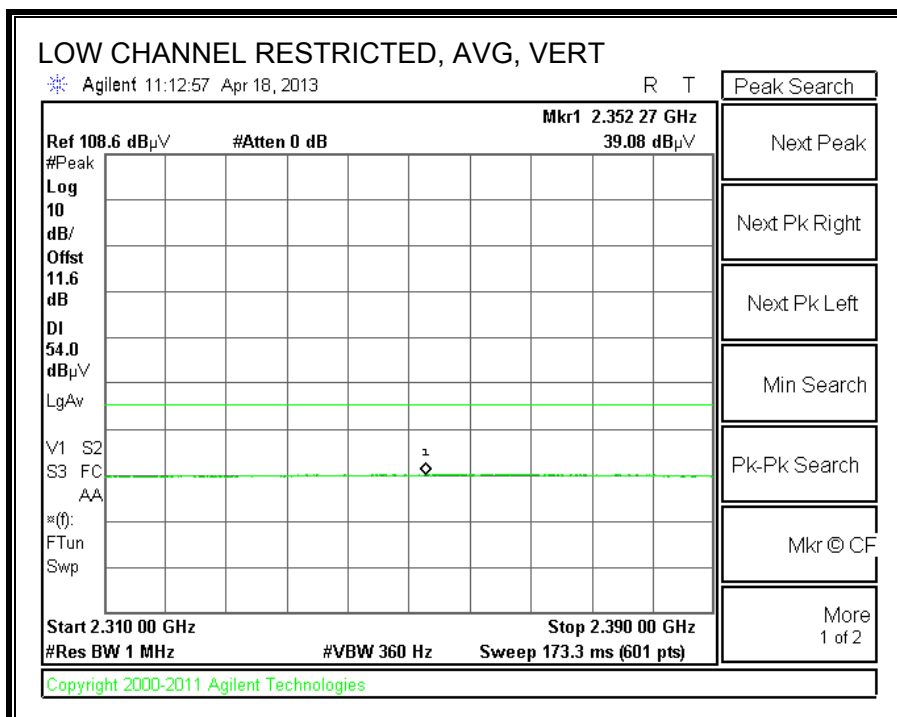
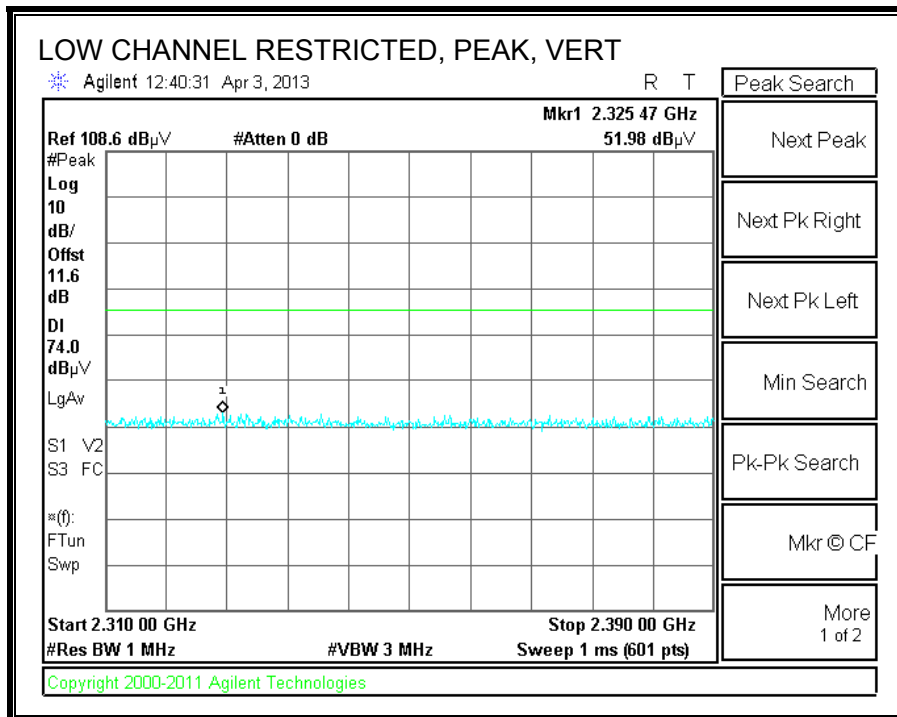

RESTRICTED BANDEDGE (HIGH CHANNEL, HORIZONTAL)

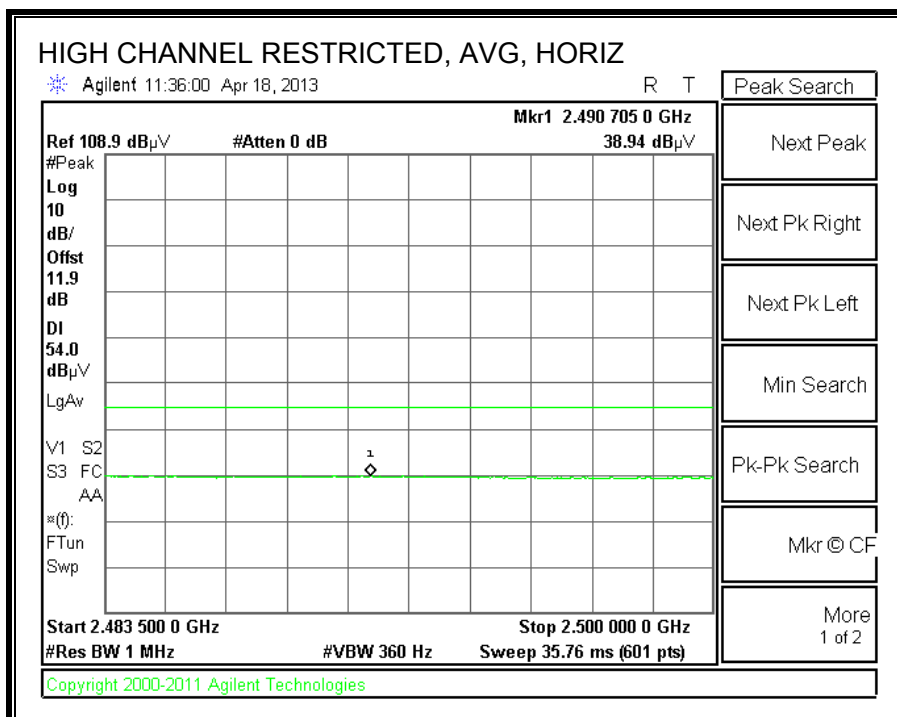
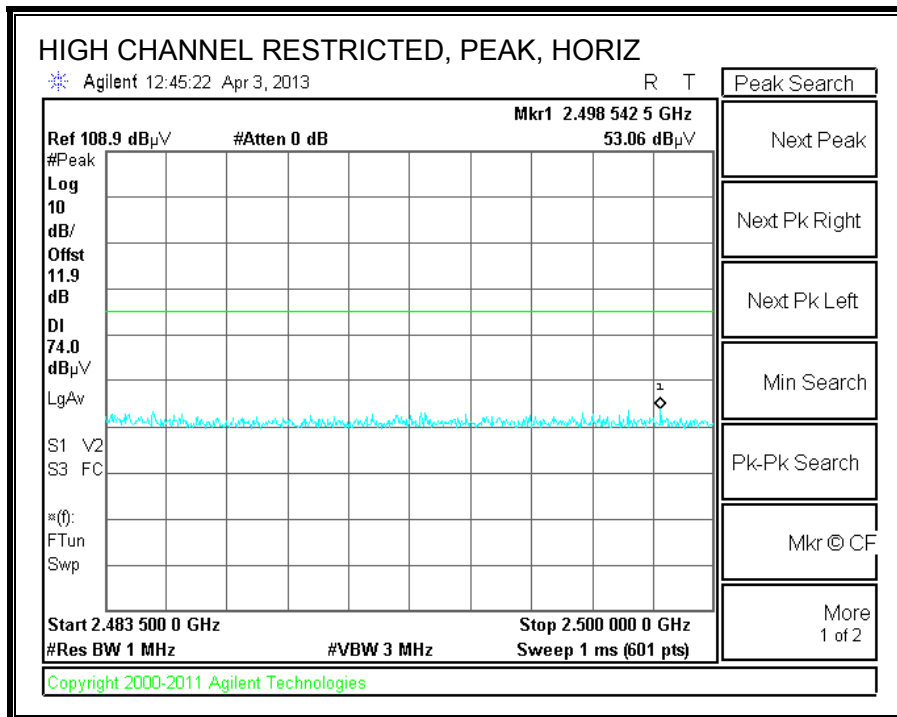

RESTRICTED BANDEDGE (HIGH CHANNEL, VERTICAL)

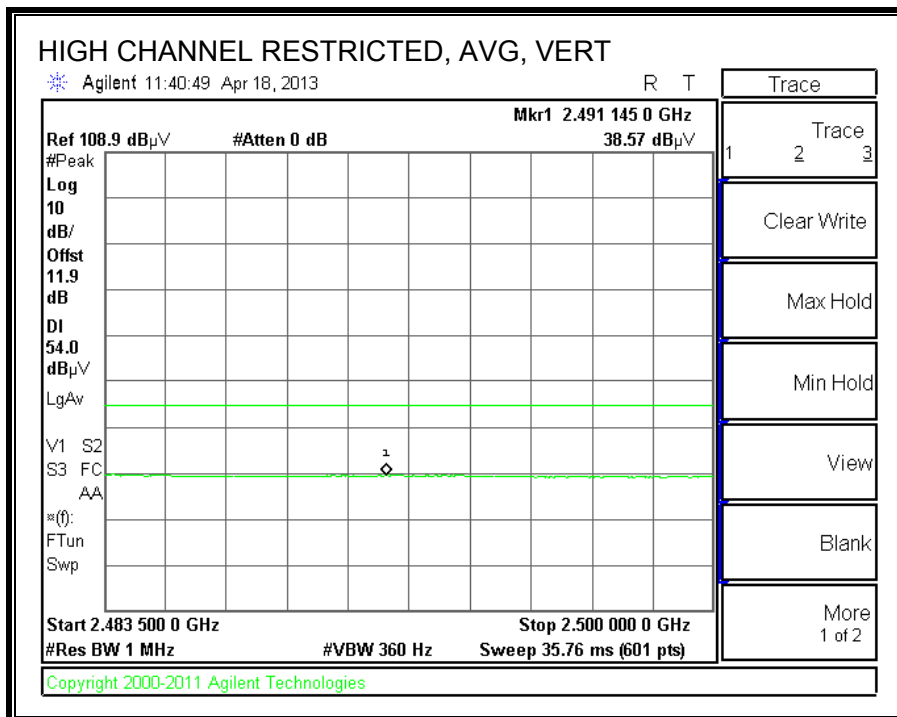
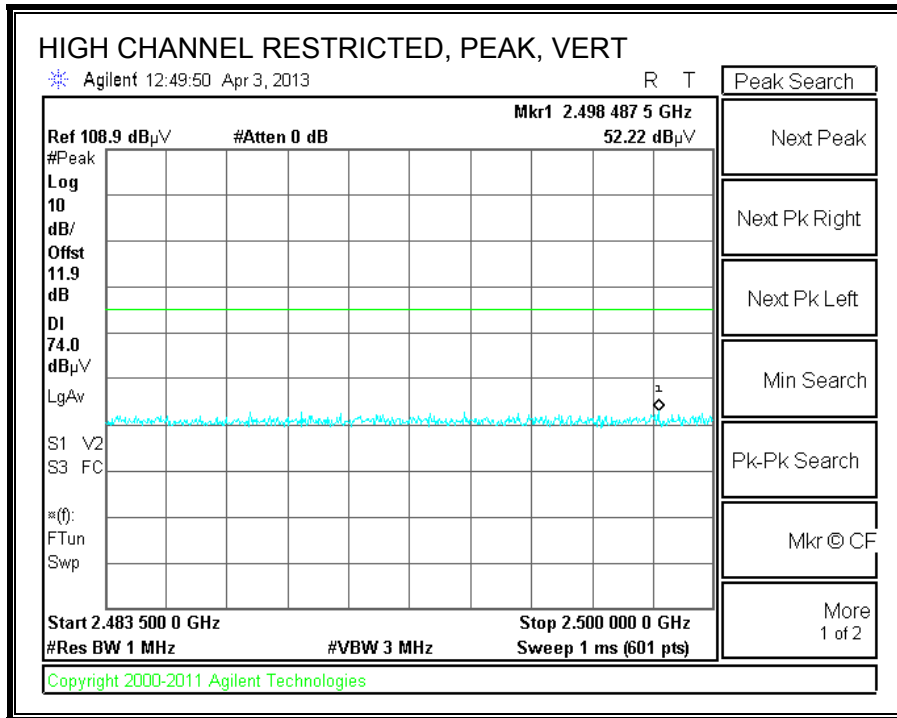

HARMONICS AND SPURIOUS EMISSIONS

LOW CHANNEL

HORIZONTAL PLOT

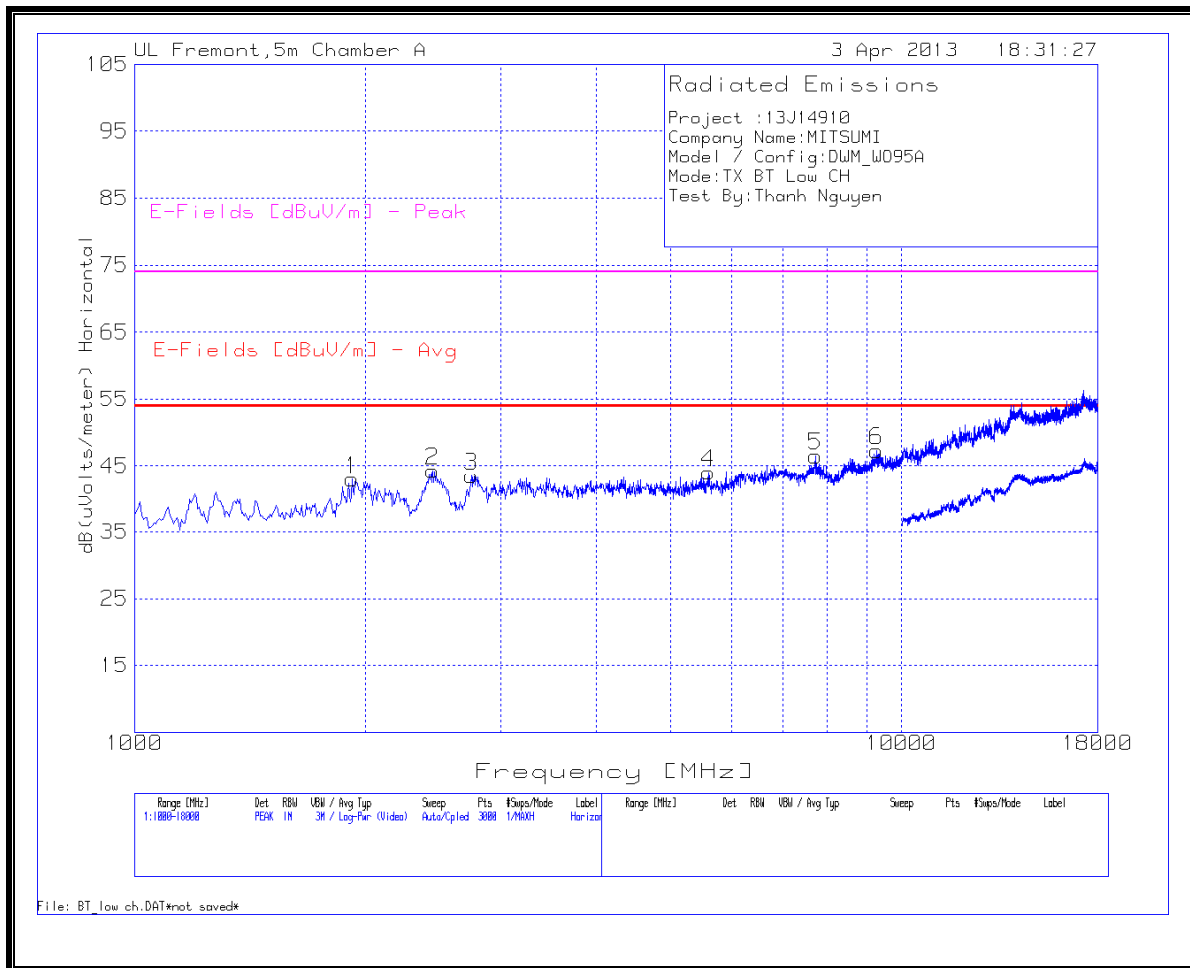

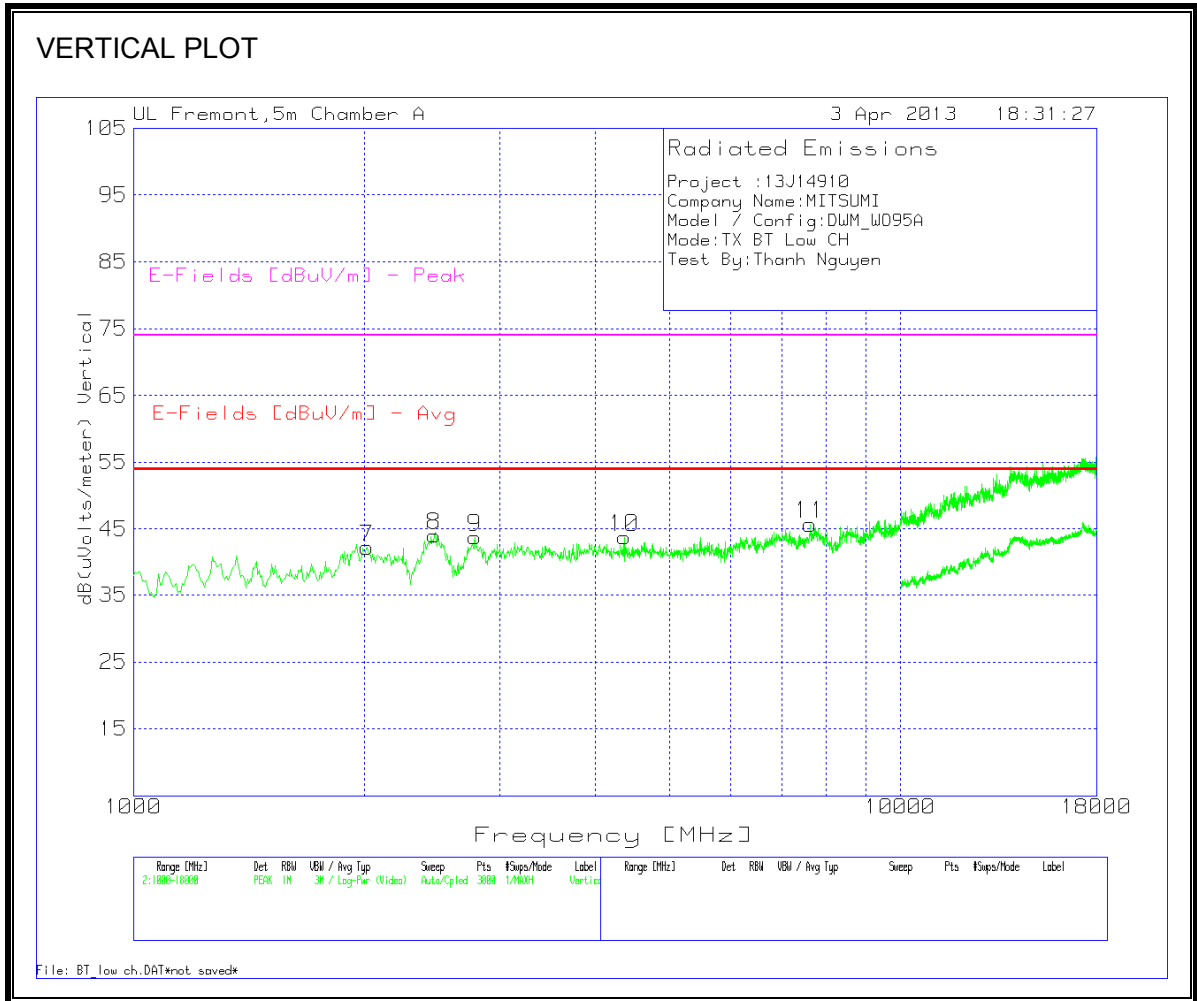

HORIZONTAL AND VERTICAL DATA														
Project :13J14910														
Company Name: MITSUMI														
Model / Config: DWM_WO95A														
Mode: TX BT Low CH														
Test By: Thanh Nguyen														
Horizontal 1000 - 18000MHz														
Marker No.	Test Frequency (MHz)	Meter Reading (dBµV)	Detector	T136 Ant Factor [dB/m]	T144 Preamp Gain [dB]	Cable Factor [dB]	T160 BRF [dB]	dB(uVolts /meter)	E-Fields [dBuV/m] - Avg	Margin (dB)	E-Fields [dBuV/m] - Peak	Margin (dB)	Height [cm]	Polarity
1	1923.051	43.69	PK	31.7	-37.2	3.9	0.9	42.99	53.97	-10.98	74	-31.01	118	Horz
2	2449.7	43.46	PK	32.3	-36.9	4.5	0.9	44.26	53.97	-9.71	74	-29.74	200	Horz
3	2749.833	41.84	PK	32.7	-36.8	4.8	0.9	43.44	53.97	-10.53	74	-30.56	118	Horz
4	5598.268	37.49	PK	34.4	-35.5	7.4	0.2	43.99	53.97	-9.98	74	-30.01	118	Horz
5	7716.189	37.55	PK	35.5	-35.9	9	0.3	46.45	53.97	-7.52	74	-27.55	118	Horz
6	9267.821	36.85	PK	36.2	-36.2	10	0.5	47.35	53.97	-6.62	74	-26.65	118	Horz
Vertical 1000 - 18000MHz														
Marker No.	Test Frequency (MHz)	Meter Reading (dBµV)	Detector	T136 Ant Factor [dB/m]	T144 Preamp Gain [dB]	Cable Factor [dB]	T160 BRF [dB]	dB(uVolts /meter)	E-Fields [dBuV/m] - Avg	Margin (dB)	E-Fields [dBuV/m] - Peak	Margin (dB)	Height [cm]	Polarity
7	2019.32	42.56	PK	31.8	-37.1	4	0.9	42.16	53.97	-11.81	74	-31.84	100	Vert
8	2466.689	43.01	PK	32.4	-36.8	4.5	0.9	44.01	53.97	-9.96	74	-29.99	100	Vert
9	2789.474	42.11	PK	32.6	-36.7	4.8	0.9	43.71	53.97	-10.26	74	-30.29	100	Vert
10	4363.757	39.47	PK	33.6	-35.9	6.4	0.2	43.77	53.97	-10.2	74	-30.23	100	Vert
11	7631.246	36.8	PK	35.5	-35.8	8.9	0.3	45.7	53.97	-8.27	74	-28.3	200	Vert

Note: No emissions found above noise floor from 18 – 26GHz.

MID CHANNEL

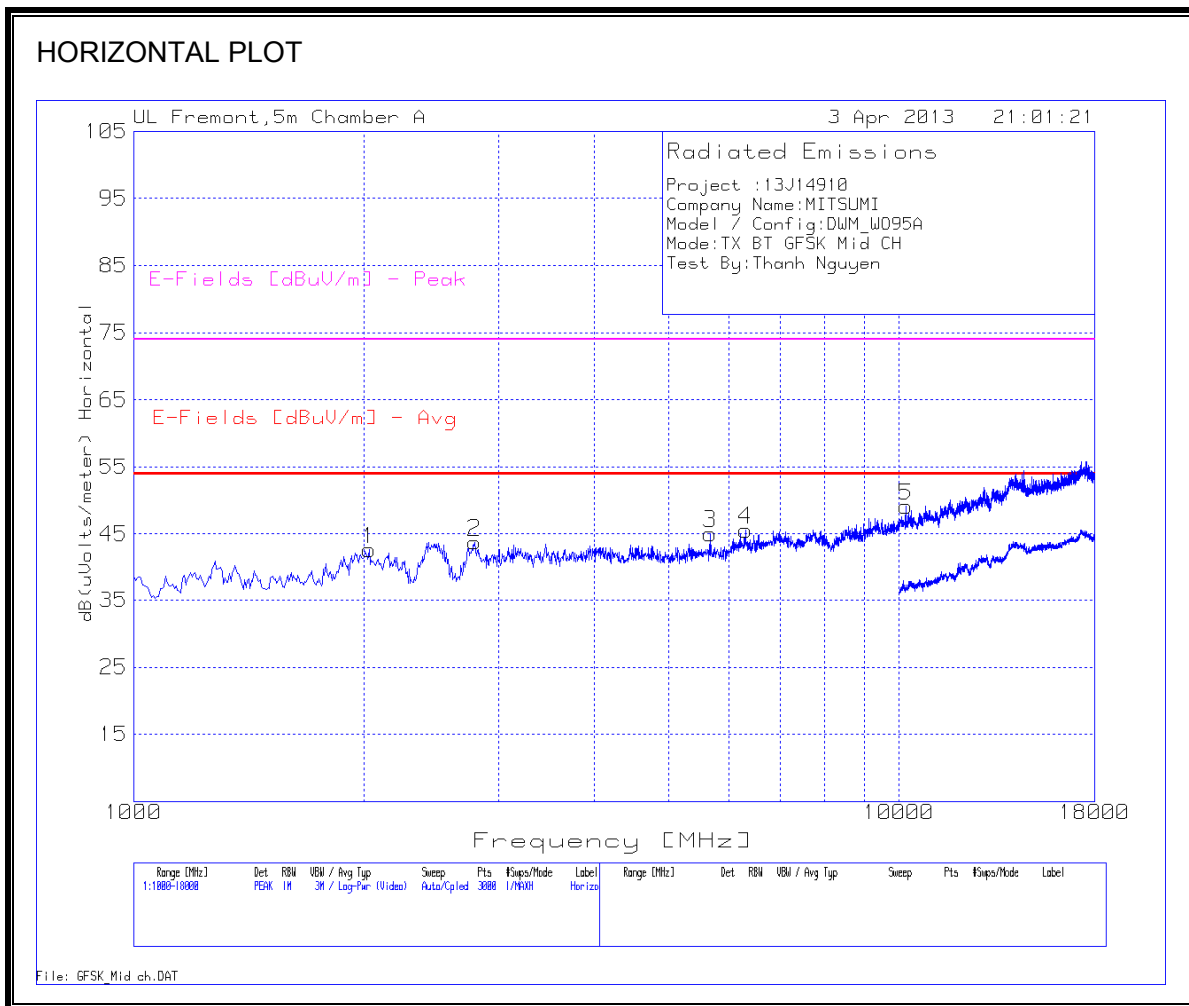

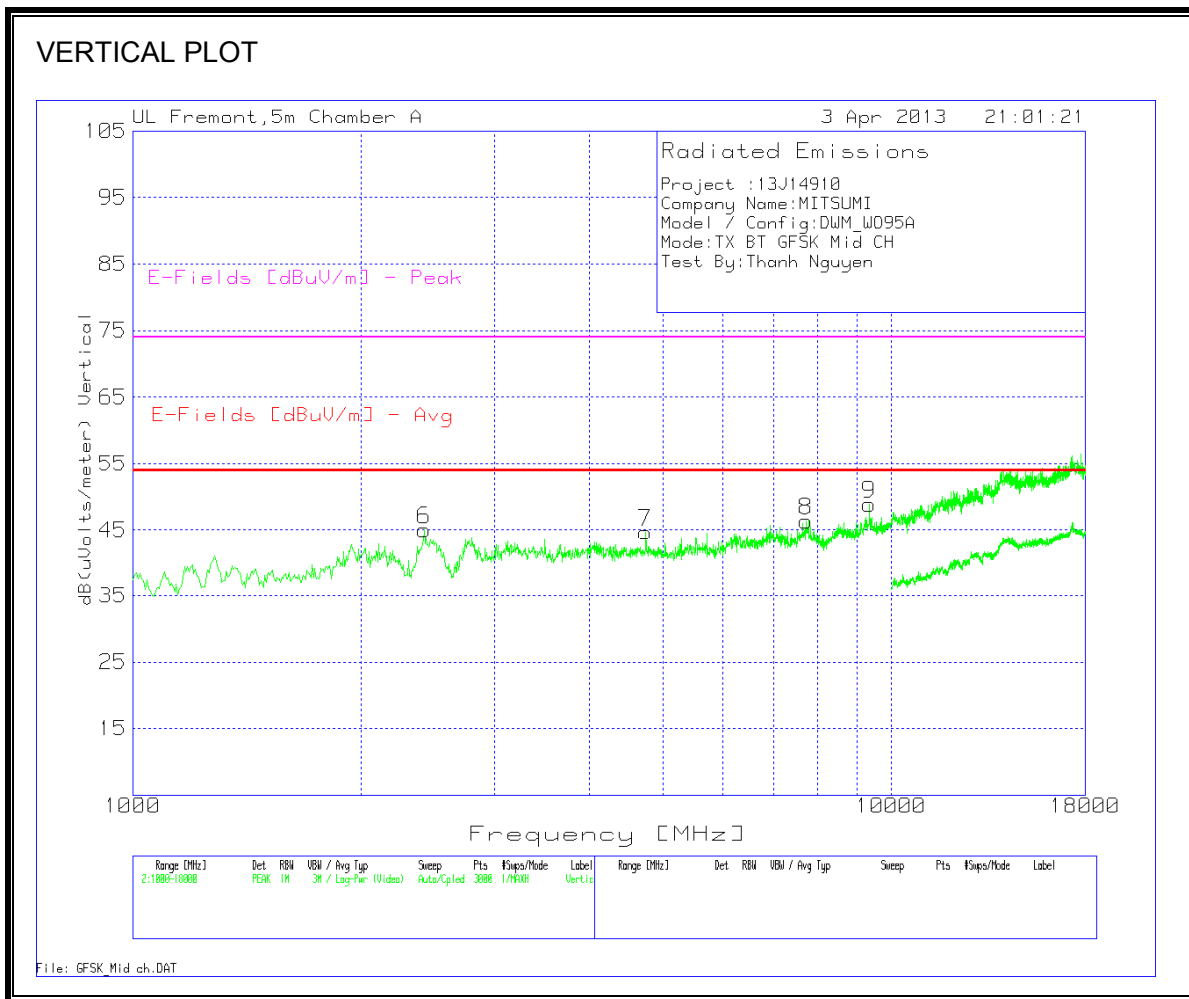

HORIZONTAL AND VERTICAL DATA														
Project :13J14910														
Company Name: MITSUMI														
Model / Config: DWM_WO95A														
Mode: TX BT GFSK Mid CH														
Test By: Thanh Nguyen														
Horizontal 1000 - 18000MHz														
Marker No.	Test Frequency (MHz)	Meter Reading (dBµV)	Detector	T136 Ant Factor [dB/m]	T144 Preamp Gain [dB]	Cable Factor [dB]	T160 BRF [dB]	dB(uVolts /meter)	E-Fields [dBuV/m] - Avg	Margin (dB)	E-Fields [dBuV/m] - Peak	Margin (dB)	Height [cm]	Polarity
1	2030.646	42.84	PK	31.8	-37.1	4.1	0.9	42.54	53.97	-11.43	74	-31.46	158	Horz
2	2789.474	42.15	PK	32.6	-36.7	4.8	0.9	43.75	53.97	-10.22	74	-30.25	200	Horz
3	5660.56	38.44	PK	34.5	-35.5	7.4	0.2	45.04	53.97	-8.93	74	-28.96	200	Horz
4	6300.466	37.58	PK	35.5	-35.6	7.9	0.2	45.58	53.97	-8.39	74	-28.42	158	Horz
5	10213.524	36.99	PK	37.2	-36.2	10.5	0.6	49.09	53.97	-4.88	74	-24.91	200	Horz
Vertical 1000 - 18000MHz														
Marker No.	Test Frequency (MHz)	Meter Reading (dBµV)	Detector	T136 Ant Factor [dB/m]	T144 Preamp Gain [dB]	Cable Factor [dB]	T160 BRF [dB]	dB(uVolts /meter)	E-Fields [dBuV/m] - Avg	Margin (dB)	E-Fields [dBuV/m] - Peak	Margin (dB)	Height [cm]	Polarity
6	2421.386	44.34	PK	32.2	-36.9	4.5	0.9	45.04	53.97	-8.93	74	-28.96	200	Vert
7	4743.171	39.55	PK	33.9	-35.7	6.7	0.2	44.65	53.97	-9.32	74	-29.35	200	Vert
8	7716.189	37.43	PK	35.5	-35.9	9	0.3	46.33	53.97	-7.64	74	-27.67	200	Vert
9	9352.765	38.17	PK	36.4	-36.2	10	0.5	48.87	53.97	-5.1	74	-25.13	200	Vert

Note: No emissions found above noise floor from 18 – 26GHz.

HIGH CHANNEL

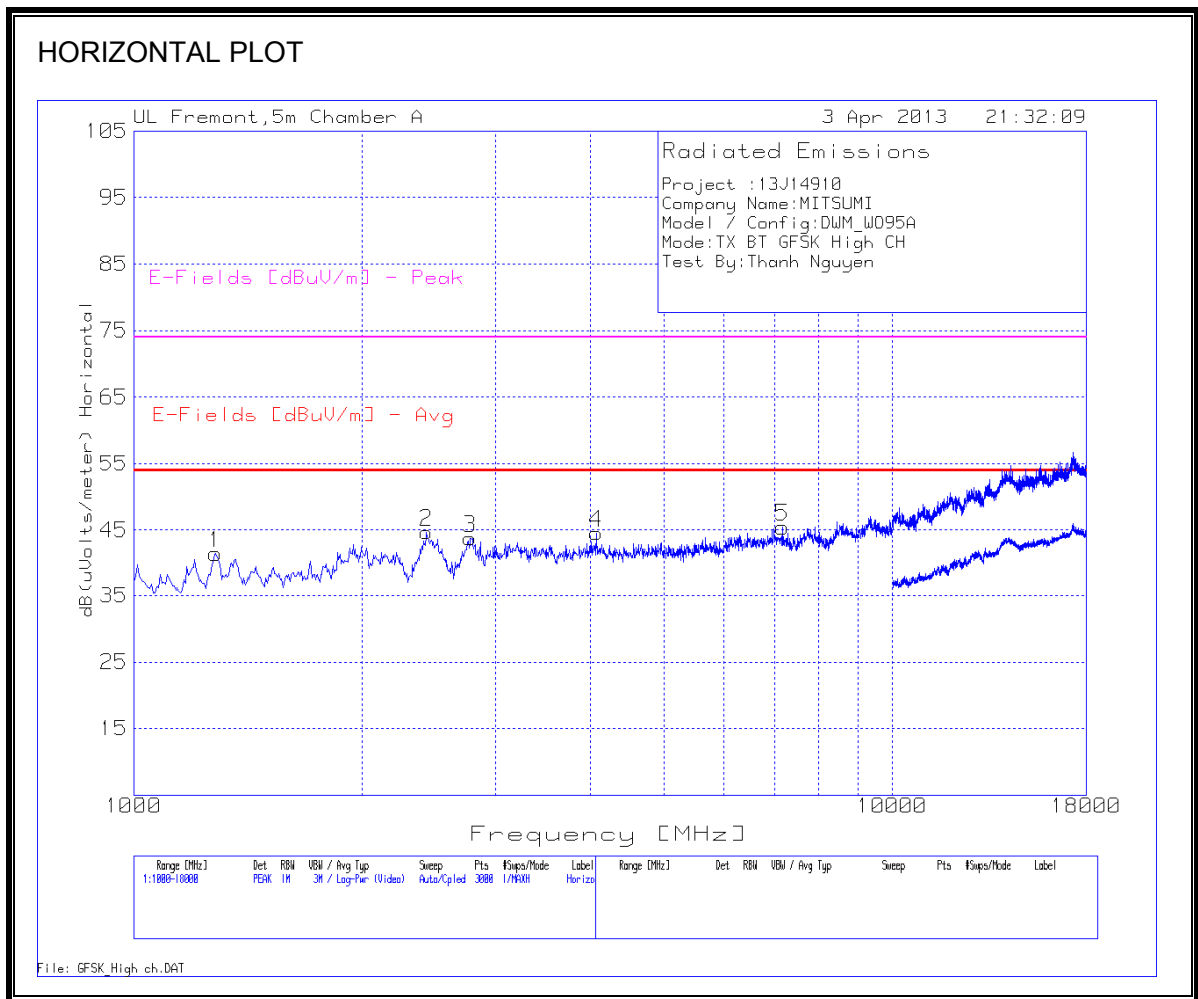

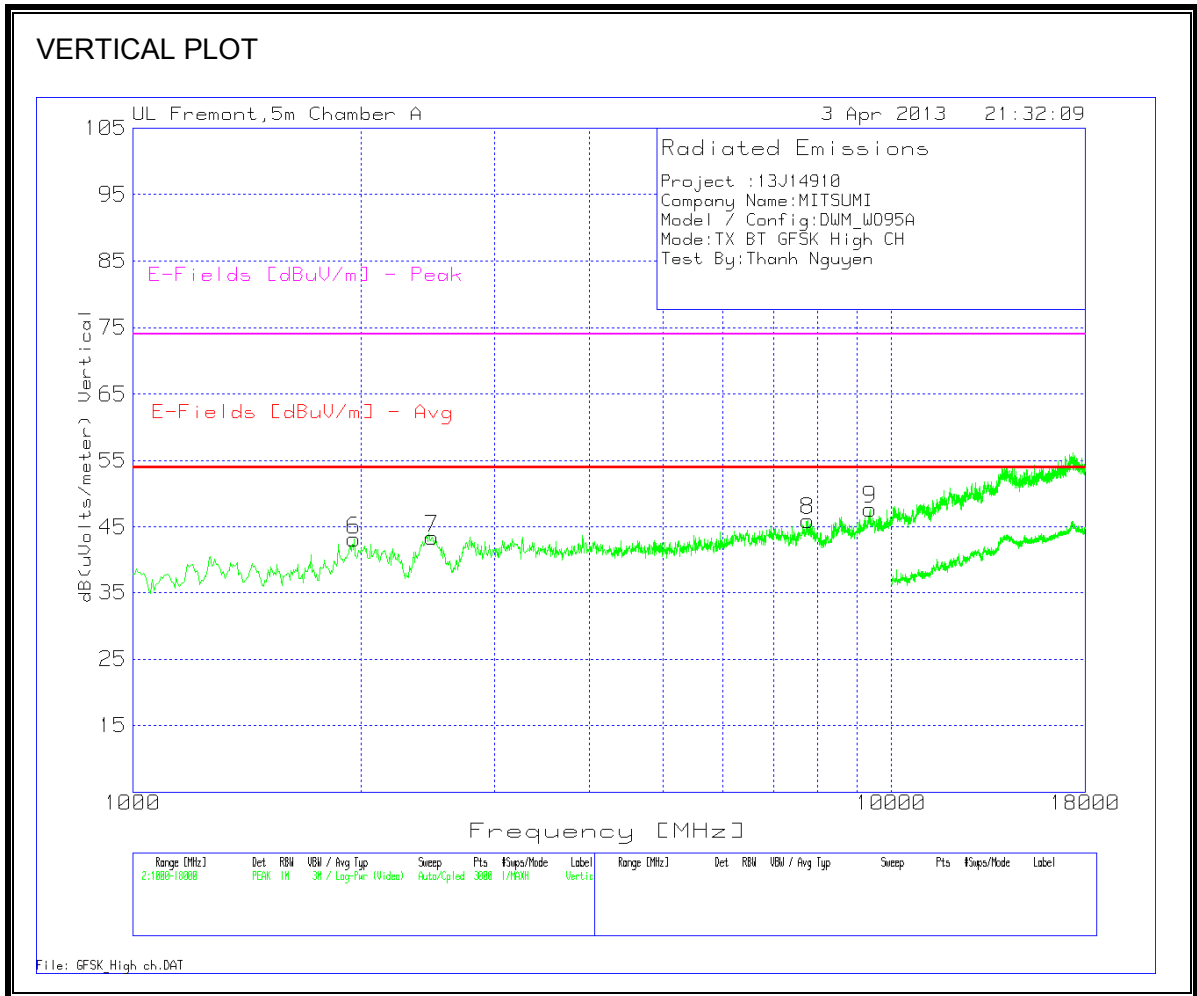

HORIZONTAL AND VERTICAL DATA

Project :13J14910														
Company Name:MITSUMI														
Model / Config:DWM_WO95A														
Mode:TX BT GFSK High CH														
Test By:Thanh Nguyen														
Horizontal 1000 - 18000MHz														
Marker No.	Test Frequency (MHz)	Meter Reading (dBµV)	Detector	T136 Ant Factor [dB/m]	T144 Preamp Gain [dB]	Cable Factor [dB]	T160 BRF [dB]	dB(uVolts /meter)	E-Fields [dBuV/m] - Avg	Margin (dB)	E-Fields [dBuV/m] - Peak	Margin (dB)	Height [cm]	Polarity
1	1283.145	45.63	PK	30.2	-38.2	3.3	0.4	41.33	53.97	-12.64	74	-32.67	100	Horz
2	2432.712	43.88	PK	32.3	-36.9	4.5	0.9	44.68	53.97	-9.29	74	-29.32	100	Horz
3	2778.148	42.14	PK	32.6	-36.7	4.8	0.9	43.74	53.97	-10.23	74	-30.26	200	Horz
4	4069.287	40.28	PK	33.8	-35.9	6.1	0.3	44.58	53.97	-9.39	74	-29.42	100	Horz
5	7155.563	36.94	PK	35.4	-35.7	8.6	0.2	45.44	53.97	-8.53	74	-28.56	200	Horz
Vertical 1000 - 18000MHz														
Marker No.	Test Frequency (MHz)	Meter Reading (dBµV)	Detector	T136 Ant Factor [dB/m]	T144 Preamp Gain [dB]	Cable Factor [dB]	T160 BRF [dB]	dB(uVolts /meter)	E-Fields [dBuV/m] - Avg	Margin (dB)	E-Fields [dBuV/m] - Peak	Margin (dB)	Height [cm]	Polarity
6	1957.029	43.42	PK	31.8	-37.1	4	0.9	43.02	53.97	-10.95	74	-30.98	200	Vert
7	2483.678	42.25	PK	32.5	-36.8	4.5	0.9	43.35	53.97	-10.62	74	-30.65	200	Vert
8	7750.167	37.07	PK	35.5	-35.9	9	0.3	45.97	53.97	-8	74	-28.03	200	Vert
9	9375.416	37.05	PK	36.4	-36.2	10	0.4	47.65	53.97	-6.32	74	-26.35	200	Vert

Note: No emissions found above noise floor from 18 – 26GHz.

8.2.2. ENHANCED DATA RATE 8PSK MODULATION

RESTRICTED BANDEDGE (LOW CHANNEL, HORIZONTAL)

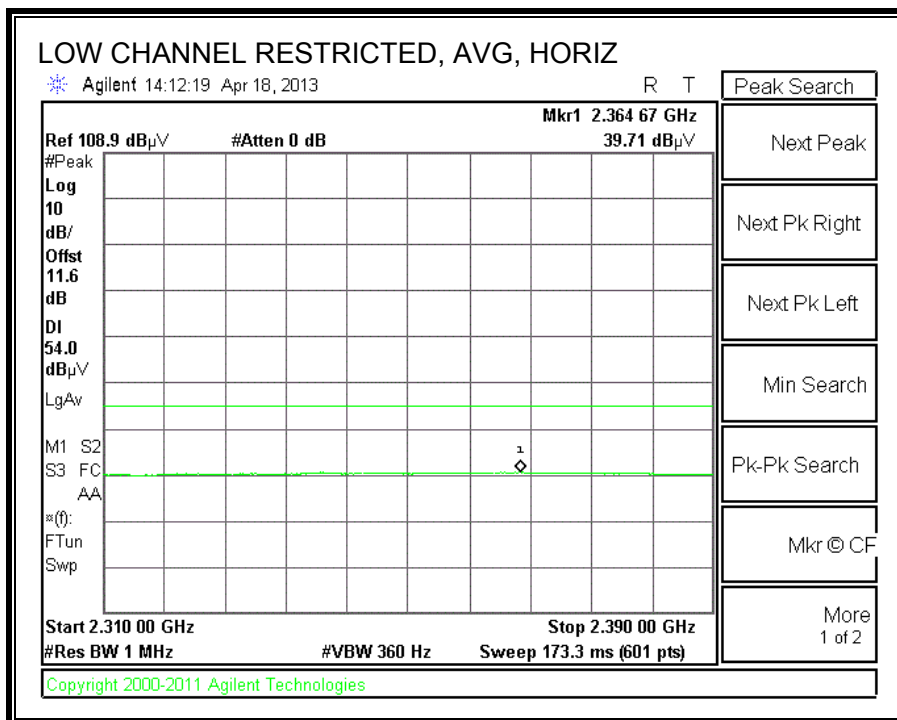
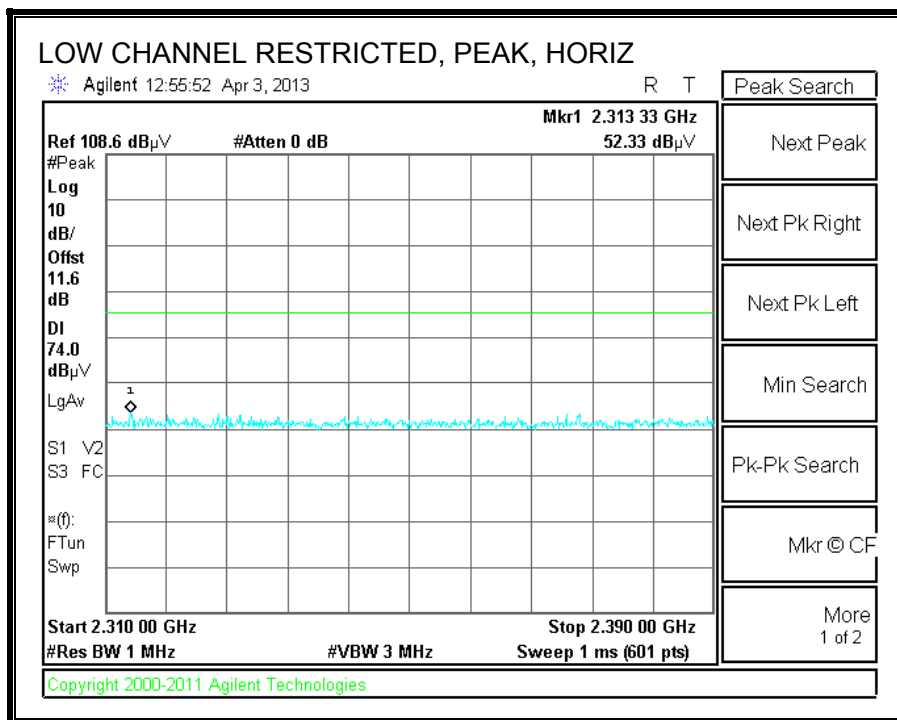

RESTRICTED BANDEDGE (LOW CHANNEL, VERTICAL)

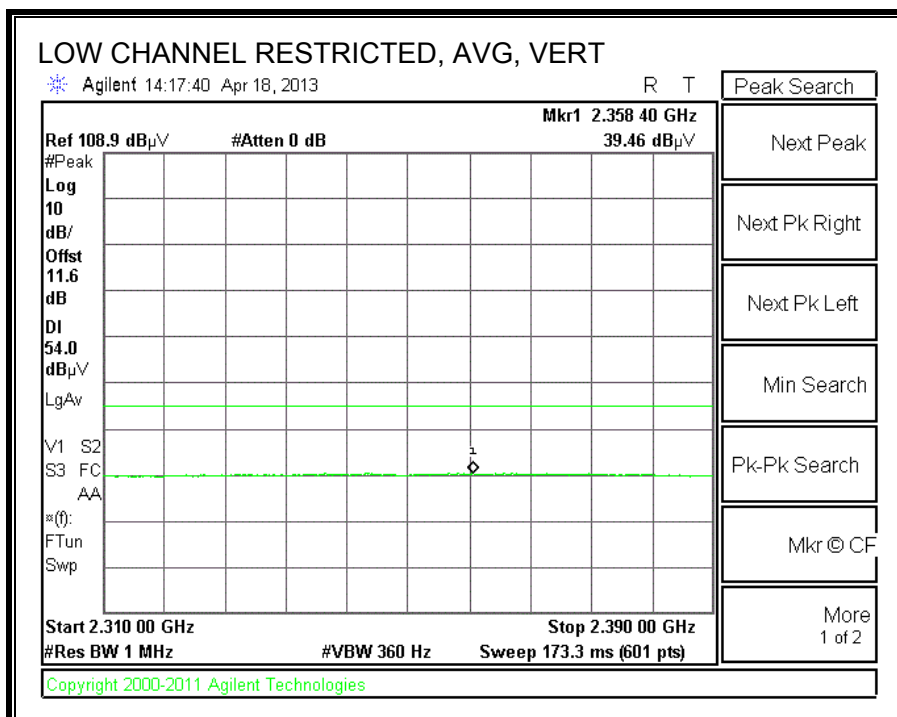
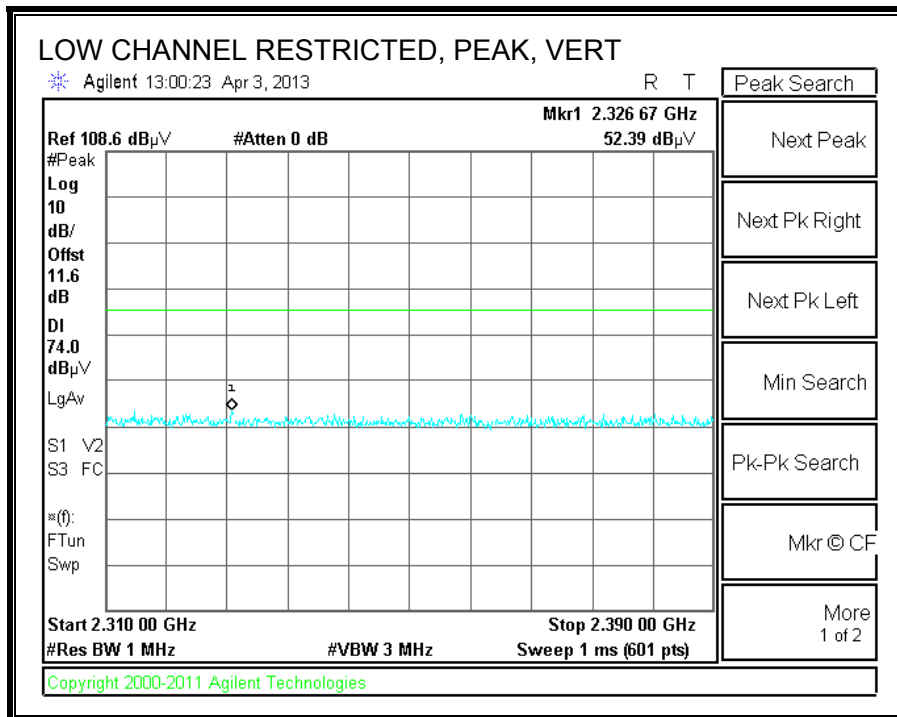

RESTRICTED BANDEDGE (HIGH CHANNEL, HORIZONTAL)

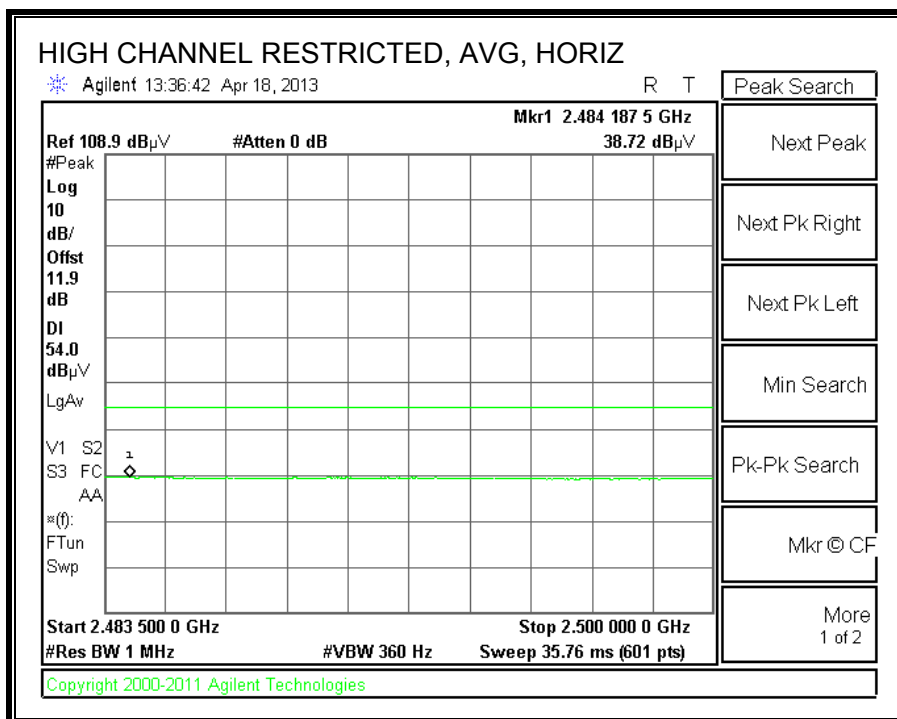
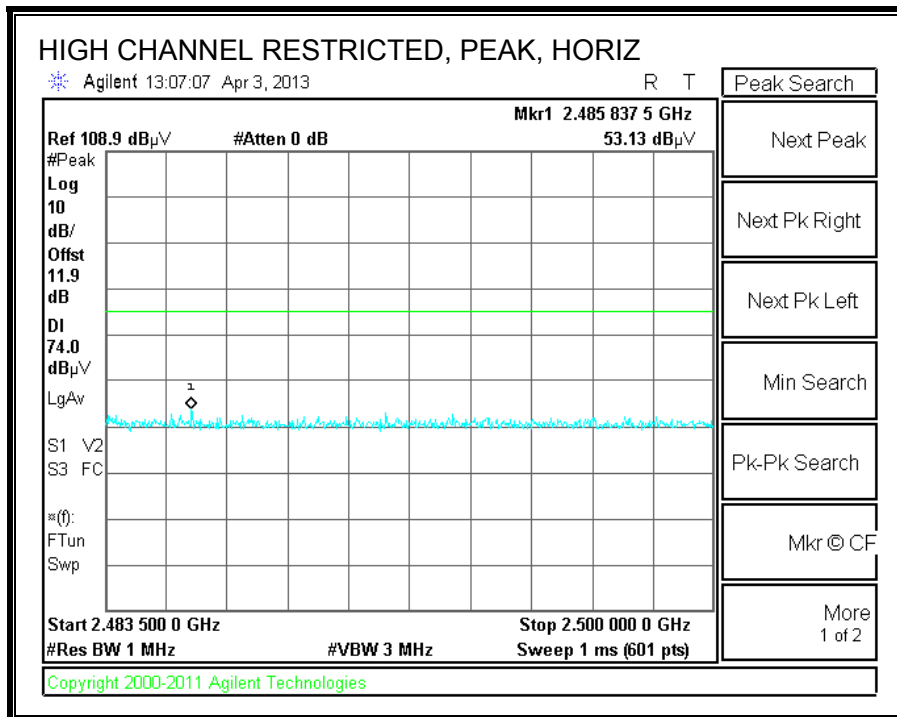

RESTRICTED BANDEDGE (HIGH CHANNEL, VERTICAL)

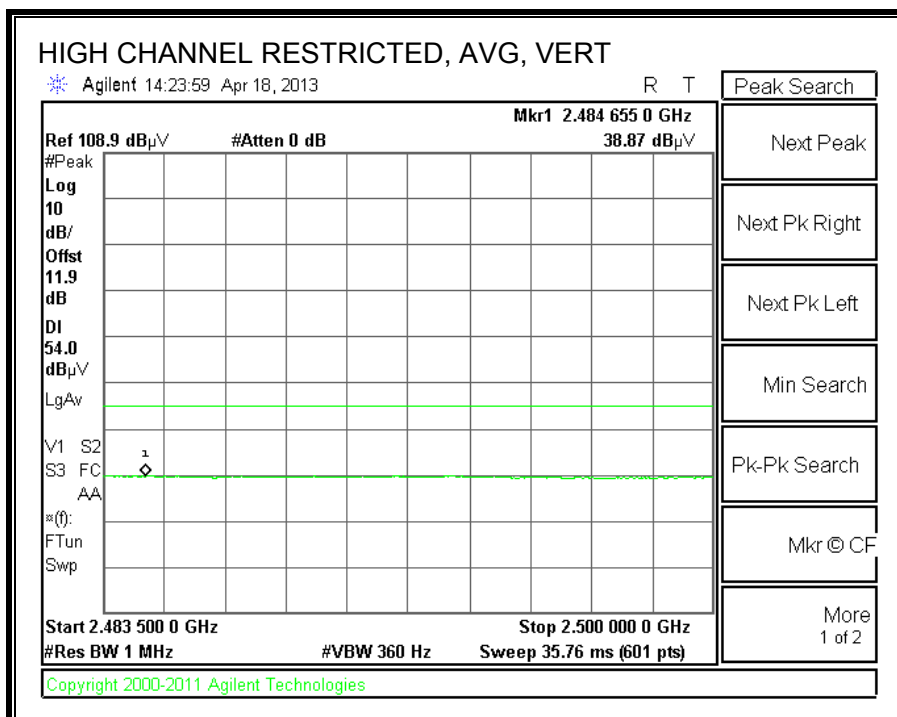
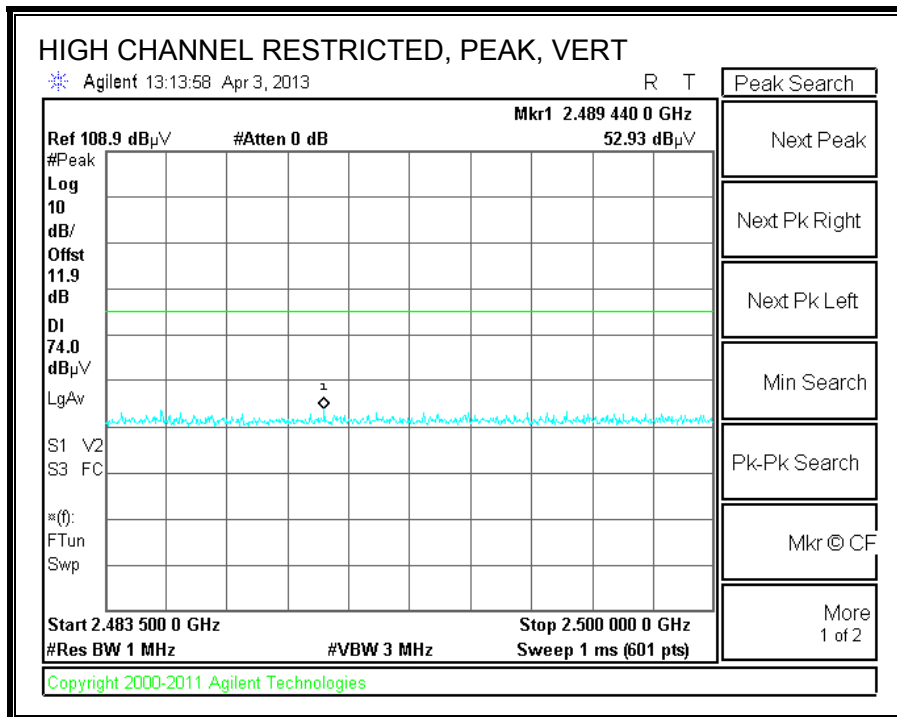

HARMONICS AND SPURIOUS EMISSIONS

LOW CHANNEL

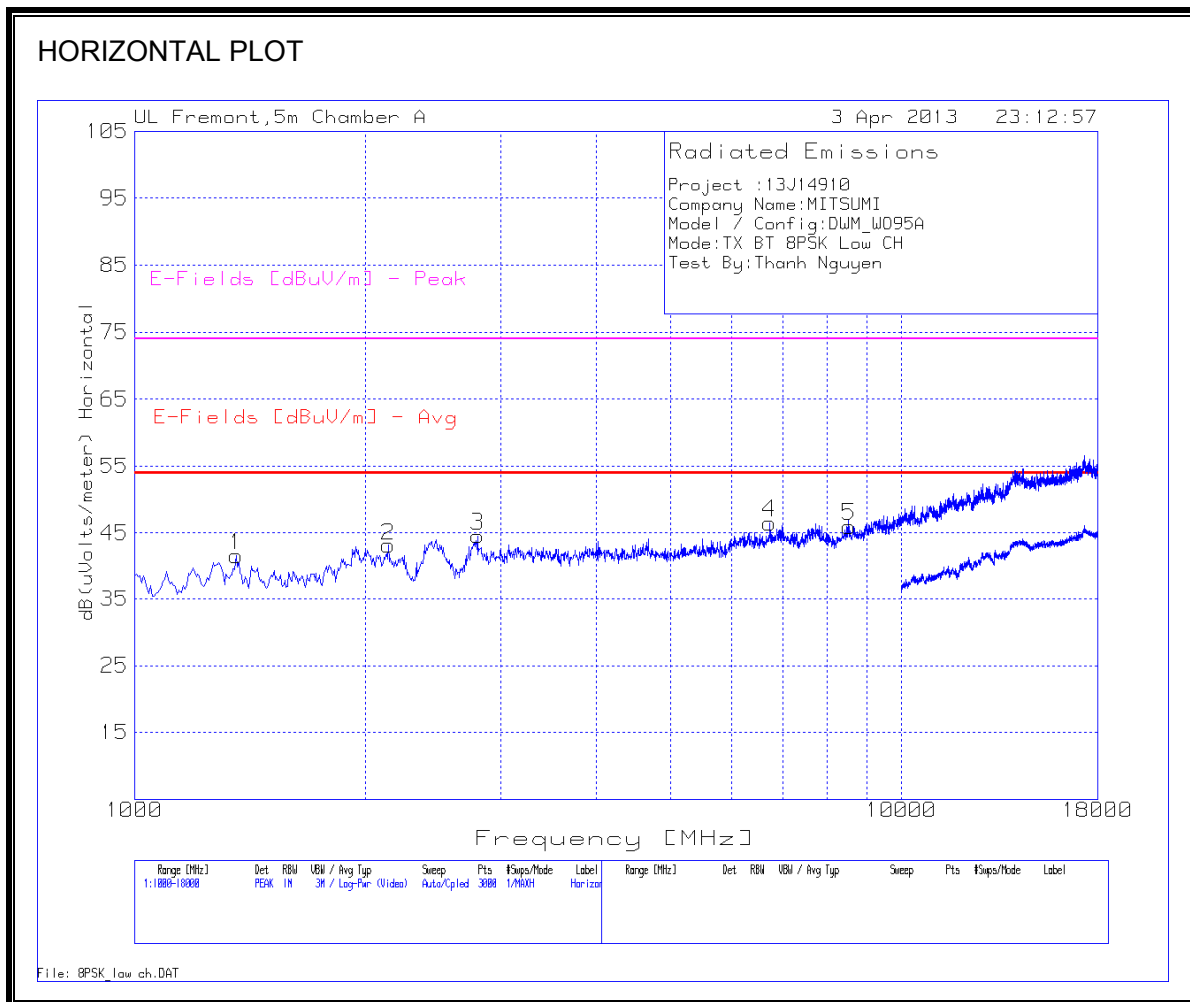

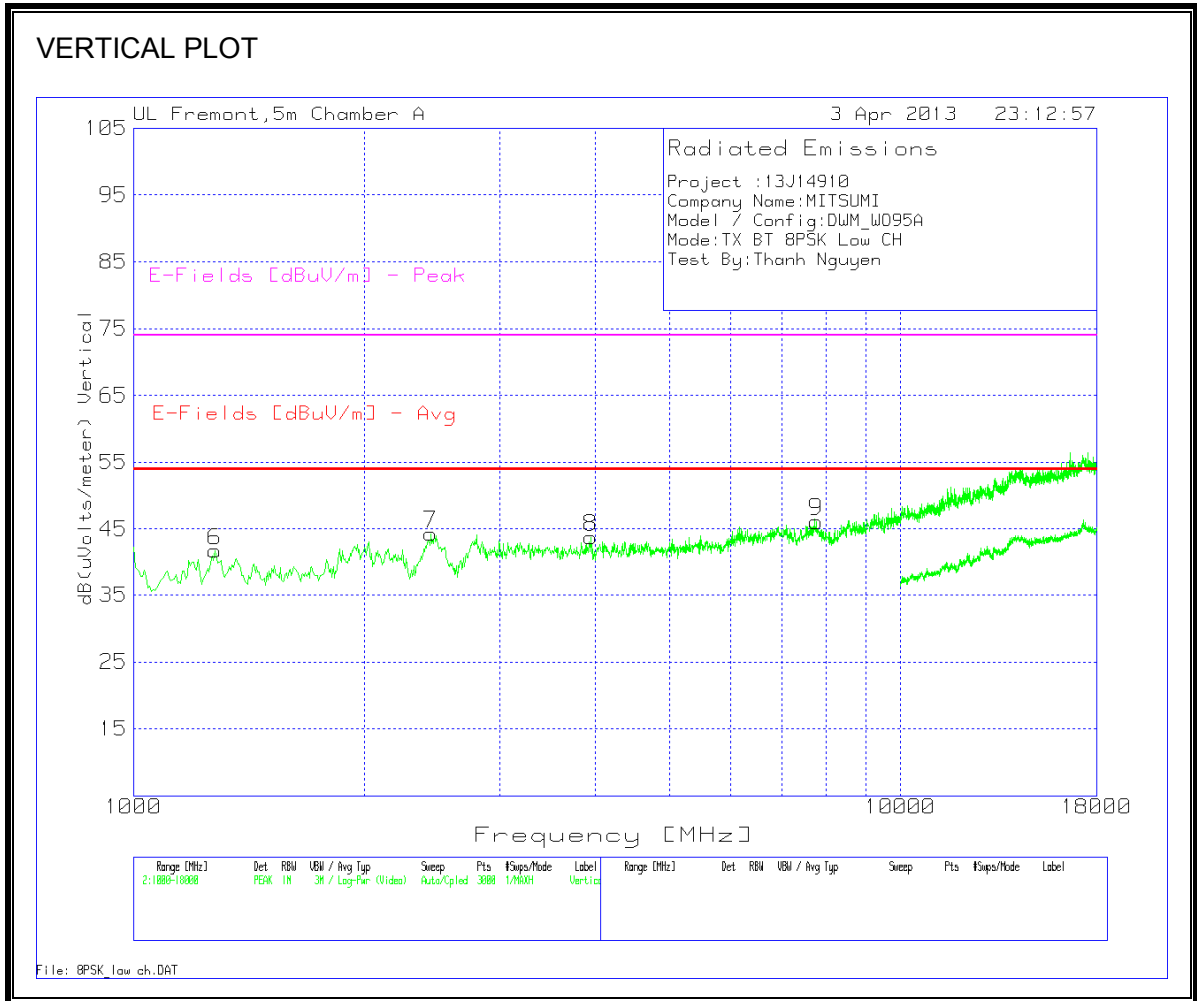

HORIZONTAL AND VERTICAL DATA														
Project :13J14910														
Company Name:MITSUMI														
Model / Config:DWM_WO95A														
Mode:TX BT 8PSK Low CH														
Test By:Thanh Nguyen														
Horizontal 1000 - 18000MHz														
Marker No.	Test Frequency (MHz)	Meter Reading (dBµV)	Detector	T136 Ant Factor [dB/m]	T144 Preamp Gain [dB]	Cable Factor [dB]	T160 BRF [dB]	dB(uVolts /meter)	E-Fields [dBuV/m] - Avg	Margin (dB)	E-Fields [dBuV/m] - Peak	Margin (dB)	Height [cm]	Polarity
1	1356.762	45.73	PK	30	-38.1	3.4	0.4	41.43	53.97	-12.54	74	-32.57	129	Horz
2	2143.904	43.3	PK	31.6	-37	4.2	0.9	43	53.97	-10.97	74	-31	129	Horz
3	2800.799	42.95	PK	32.6	-36.7	4.8	0.9	44.55	53.97	-9.42	74	-29.45	200	Horz
4	6736.509	38.15	PK	35.4	-35.6	8.3	0.3	46.55	53.97	-7.42	74	-27.45	129	Horz
5	8548.634	36.23	PK	35.7	-36	9.5	0.5	45.93	53.97	-8.04	74	-28.07	129	Horz
Vertical 1000 - 18000MHz														
Marker No.	Test Frequency (MHz)	Meter Reading (dBµV)	Detector	T136 Ant Factor [dB/m]	T144 Preamp Gain [dB]	Cable Factor [dB]	T160 BRF [dB]	dB(uVolts /meter)	E-Fields [dBuV/m] - Avg	Margin (dB)	E-Fields [dBuV/m] - Peak	Margin (dB)	Height [cm]	Polarity
6	1277.482	46.27	PK	30.1	-38.3	3.3	0.3	41.67	53.97	-12.3	74	-32.33	200	Vert
7	2444.037	43.46	PK	32.3	-36.9	4.5	0.9	44.26	53.97	-9.71	74	-29.74	100	Vert
8	3950.366	39.68	PK	33.8	-36	6	0.2	43.68	53.97	-10.29	74	-30.32	200	Vert
9	7767.155	37.3	PK	35.5	-35.9	9	0.2	46.1	53.97	-7.87	74	-27.9	100	Vert

Note: No emissions found above noise floor from 18 – 26GHz.

MID CHANNEL

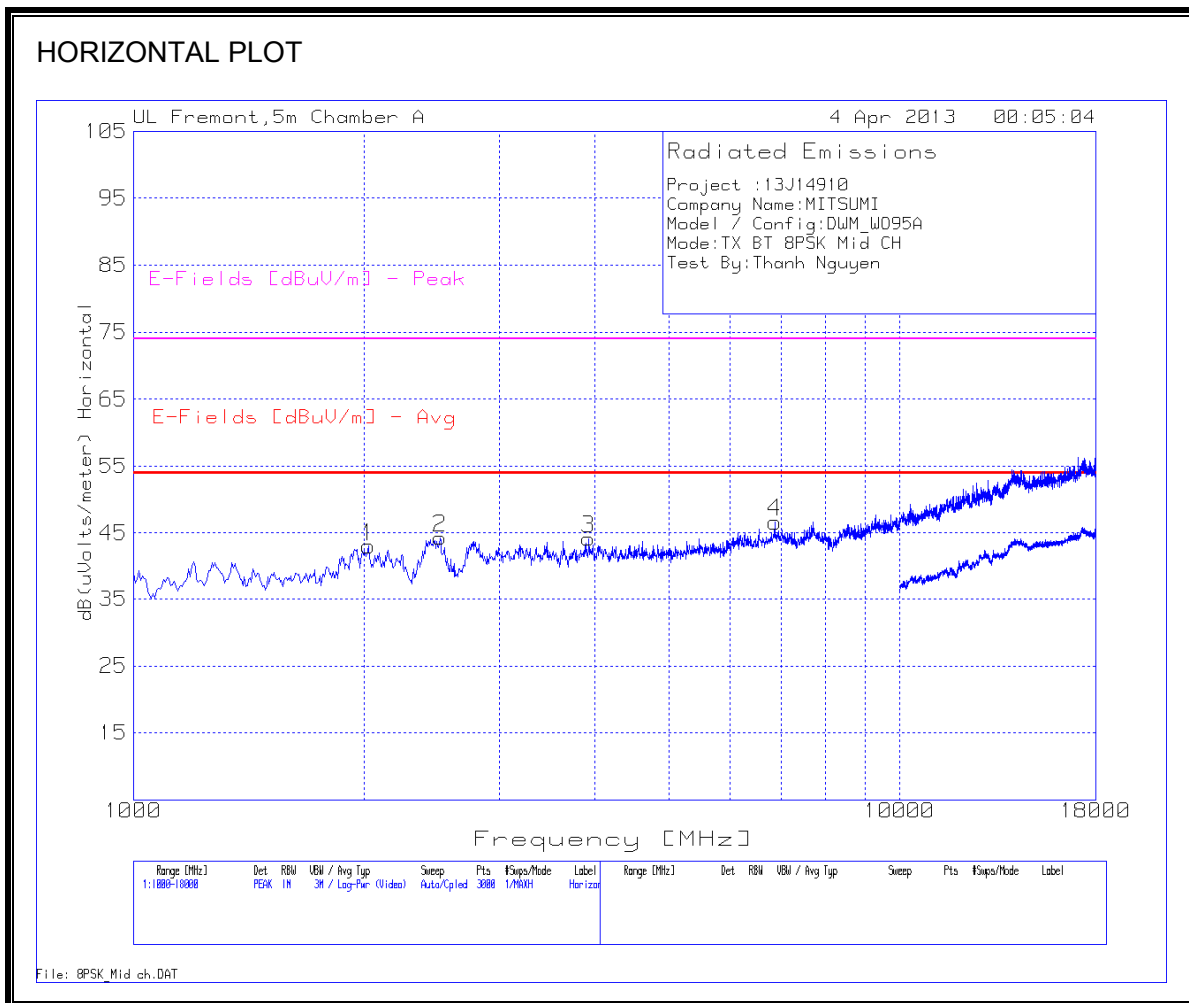

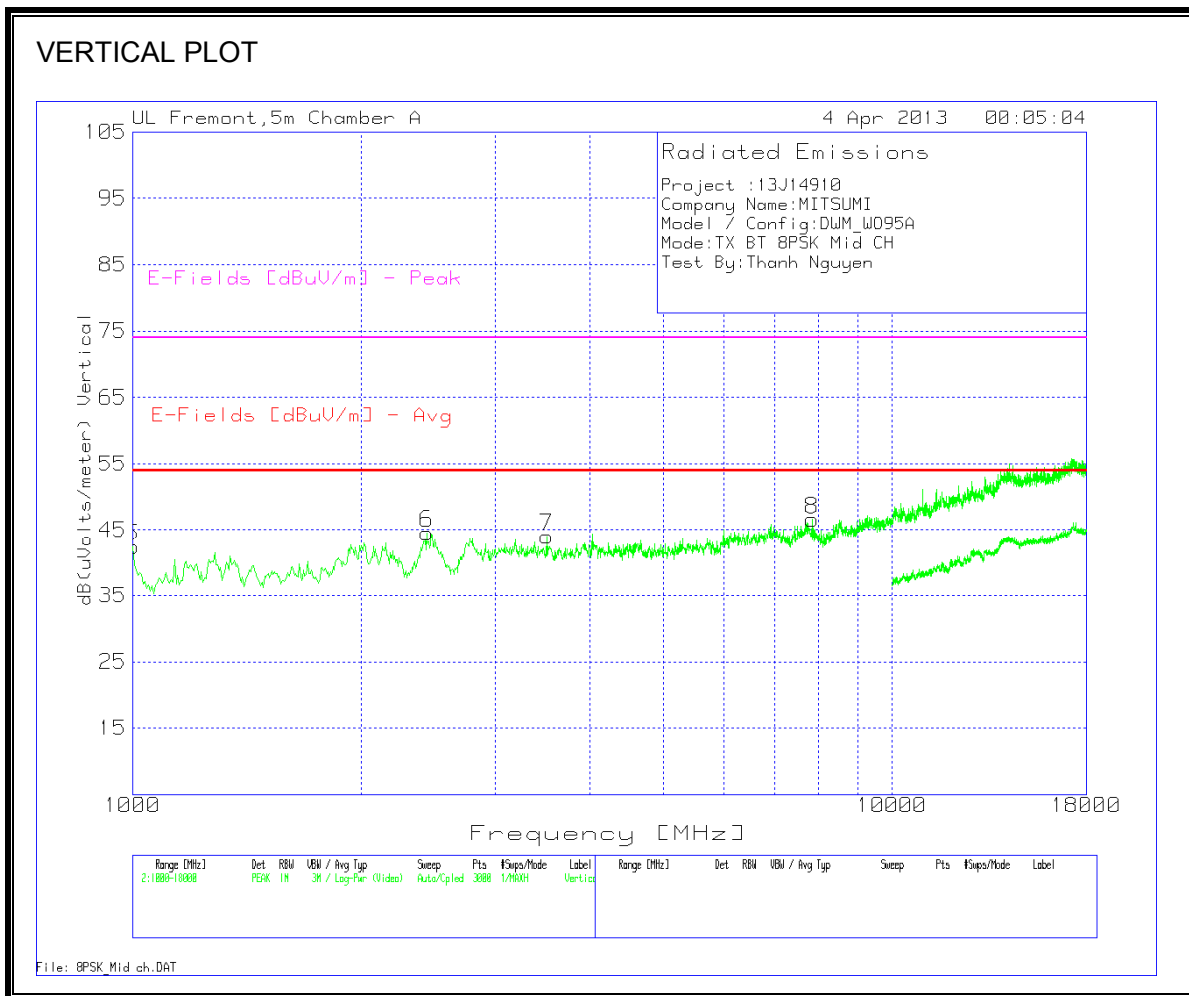

HORIZONTAL AND VERTICAL DATA														
Project :13J14910														
Company Name: MITSUMI														
Model / Config: DWM_WO95A														
Mode: TX BT 8PSK Mid CH														
Test By: Thanh Nguyen														
Horizontal 1000 - 18000MHz														
Marker No.	Test Frequency (MHz)	Meter Reading (dBµV)	Detector	T136 Ant Factor [dB/m]	T144 Preamp Gain [dB]	Cable Factor [dB]	T160 BRF [dB]	dB(uVolts /meter)	E-Fields [dBuV/m] - Avg	Margin (dB)	E-Fields [dBuV/m] - Peak	Margin (dB)	Height [cm]	Polarity
1	2024.983	43.29	PK	31.8	-37.1	4	0.9	42.89	53.97	-11.08	74	-31.11	145	Horz
2	2511.992	43.03	PK	32.6	-36.8	4.5	0.9	44.23	53.97	-9.74	74	-29.77	200	Horz
3	3927.715	40.07	PK	33.7	-36	6	0.3	44.07	53.97	-9.9	74	-29.93	200	Horz
4	6866.755	38.16	PK	35.4	-35.6	8.4	0.3	46.66	53.97	-7.31	74	-27.34	200	Horz
Vertical 1000 - 18000MHz														
Marker No.	Test Frequency (MHz)	Meter Reading (dBµV)	Detector	T136 Ant Factor [dB/m]	T144 Preamp Gain [dB]	Cable Factor [dB]	T160 BRF [dB]	dB(uVolts /meter)	E-Fields [dBuV/m] - Avg	Margin (dB)	E-Fields [dBuV/m] - Peak	Margin (dB)	Height [cm]	Polarity
5	1000	49.88	PK	28.1	-38.9	3	0.3	42.38	53.97	-11.59	74	-31.62	200	Vert
6	2438.374	43.78	PK	32.3	-36.9	4.5	0.9	44.58	53.97	-9.39	74	-29.42	200	Vert
7	3508.661	41.15	PK	33.1	-36.3	5.6	0.4	43.95	53.97	-10.02	74	-30.05	200	Vert
8	7857.761	37.57	PK	35.5	-35.9	9.1	0.3	46.57	53.97	-7.4	74	-27.43	100	Vert

Note: No emissions found above noise floor from 18 – 26GHz.

HIGH CHANNEL

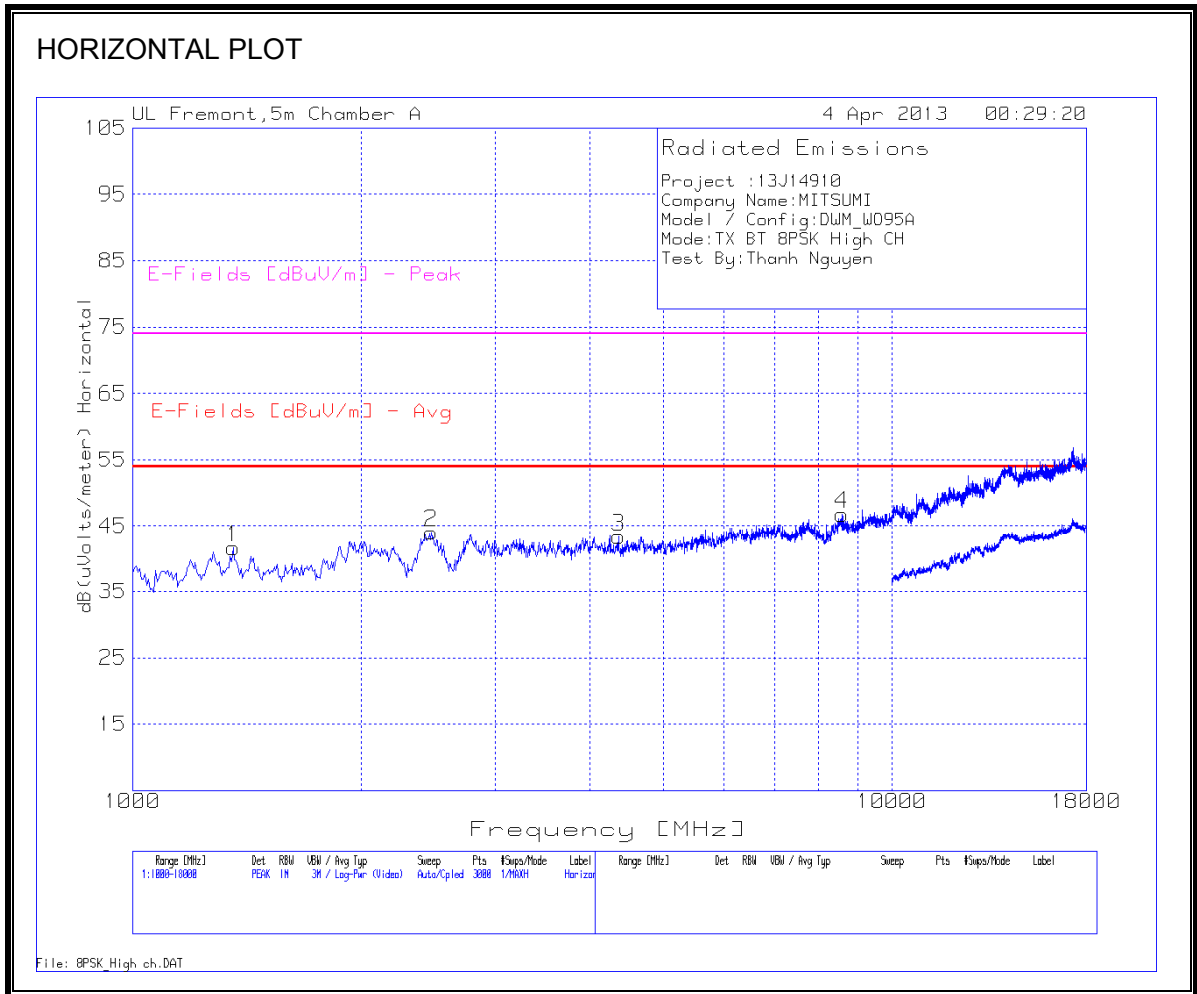

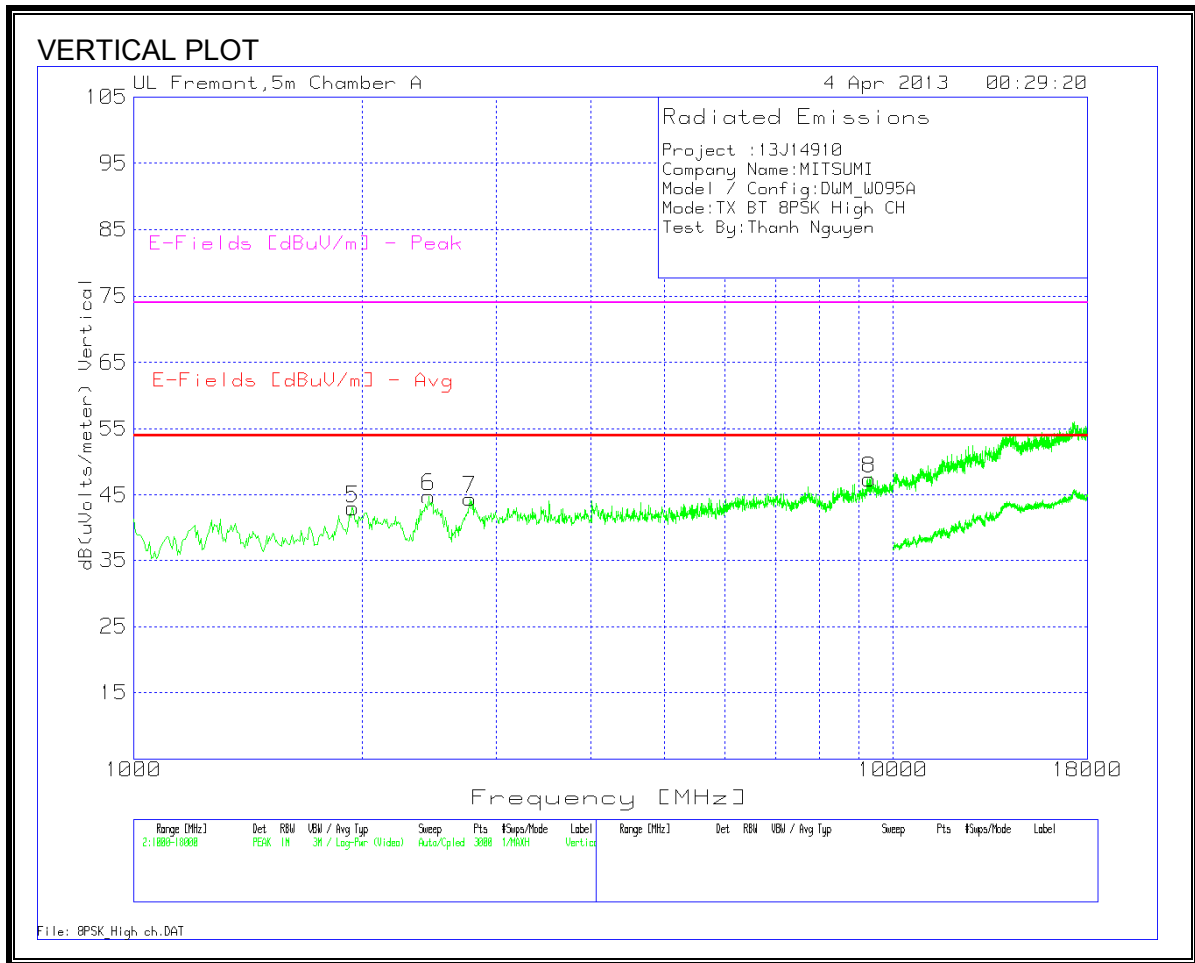

HORIZONTAL AND VERTICAL DATA														
Project :13J14910														
Company Name: MITSUMI														
Model / Config: DWM_WO95A														
Mode: TX BT 8PSK High CH														
Test By: Thanh Nguyen														
Horizontal 1000 - 18000MHz														
Marker No.	Test Frequency (MHz)	Meter Reading (dBµV)	Detector	T136 Ant Factor [dB/m]	T144 Preamp Gain [dB]	Cable Factor [dB]	T160 BRF [dB]	dB(uVolts /meter)	E-Fields [dBuV/m] - Avg	Margin (dB)	E-Fields [dBuV/m] - Peak	Margin (dB)	Height [cm]	Polarity
1	1356.762	45.96	PK	30	-38.1	3.4	0.4	41.66	53.97	-12.31	74	-32.34	100	Horz
2	2472.352	42.86	PK	32.5	-36.8	4.5	0.9	43.96	53.97	-10.01	74	-30.04	100	Horz
3	4363.757	39.06	PK	33.6	-35.9	6.4	0.2	43.36	53.97	-10.61	74	-30.64	200	Horz
4	8593.937	37.17	PK	35.7	-36	9.6	0.3	46.77	53.97	-7.2	74	-27.23	100	Horz
Vertical 1000 - 18000MHz														
Marker No.	Test Frequency (MHz)	Meter Reading (dBµV)	Detector	T136 Ant Factor [dB/m]	T144 Preamp Gain [dB]	Cable Factor [dB]	T160 BRF [dB]	dB(uVolts /meter)	E-Fields [dBuV/m] - Avg	Margin (dB)	E-Fields [dBuV/m] - Peak	Margin (dB)	Height [cm]	Polarity
5	1945.703	43.45	PK	31.8	-37.2	4	0.9	42.95	53.97	-11.02	74	-31.05	200	Vert
6	2449.7	44.03	PK	32.3	-36.9	4.5	0.9	44.83	53.97	-9.14	74	-29.17	100	Vert
7	2772.485	42.86	PK	32.6	-36.8	4.8	0.9	44.36	53.97	-9.61	74	-29.64	200	Vert
8	9290.473	36.67	PK	36.3	-36.2	10	0.6	47.37	53.97	-6.6	74	-26.63	200	Vert

Note: No emissions found above noise floor from 18 – 26GHz.

8.3. WORST-CASE BELOW 1 GHz

SPURIOUS EMISSIONS 30 TO 1000 MHz (WORST-CASE CONFIGURATION, HORIZONTAL)

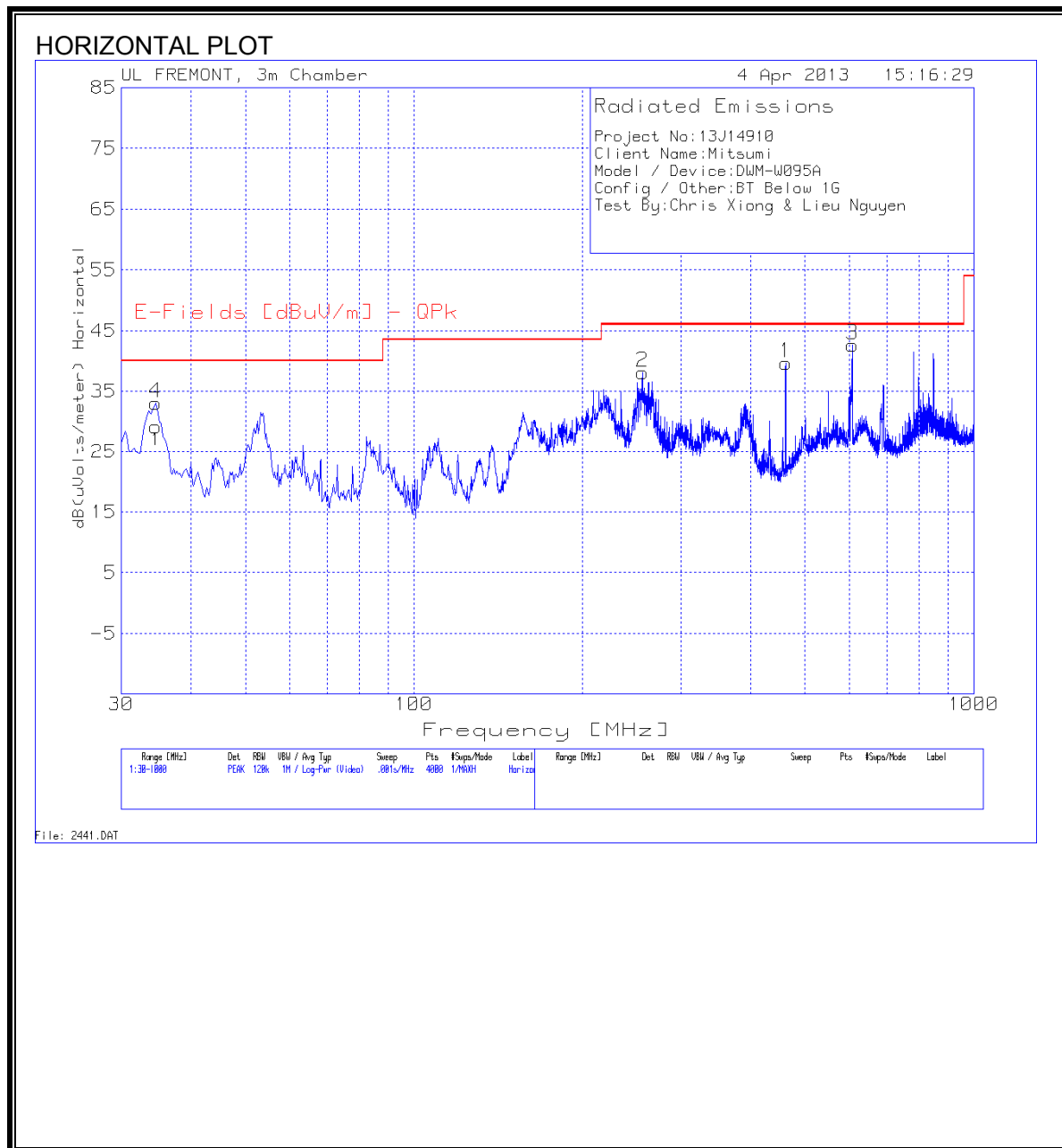

SPURIOUS EMISSIONS 30 TO 1000 MHz (WORST-CASE CONFIGURATION, VERTICAL)

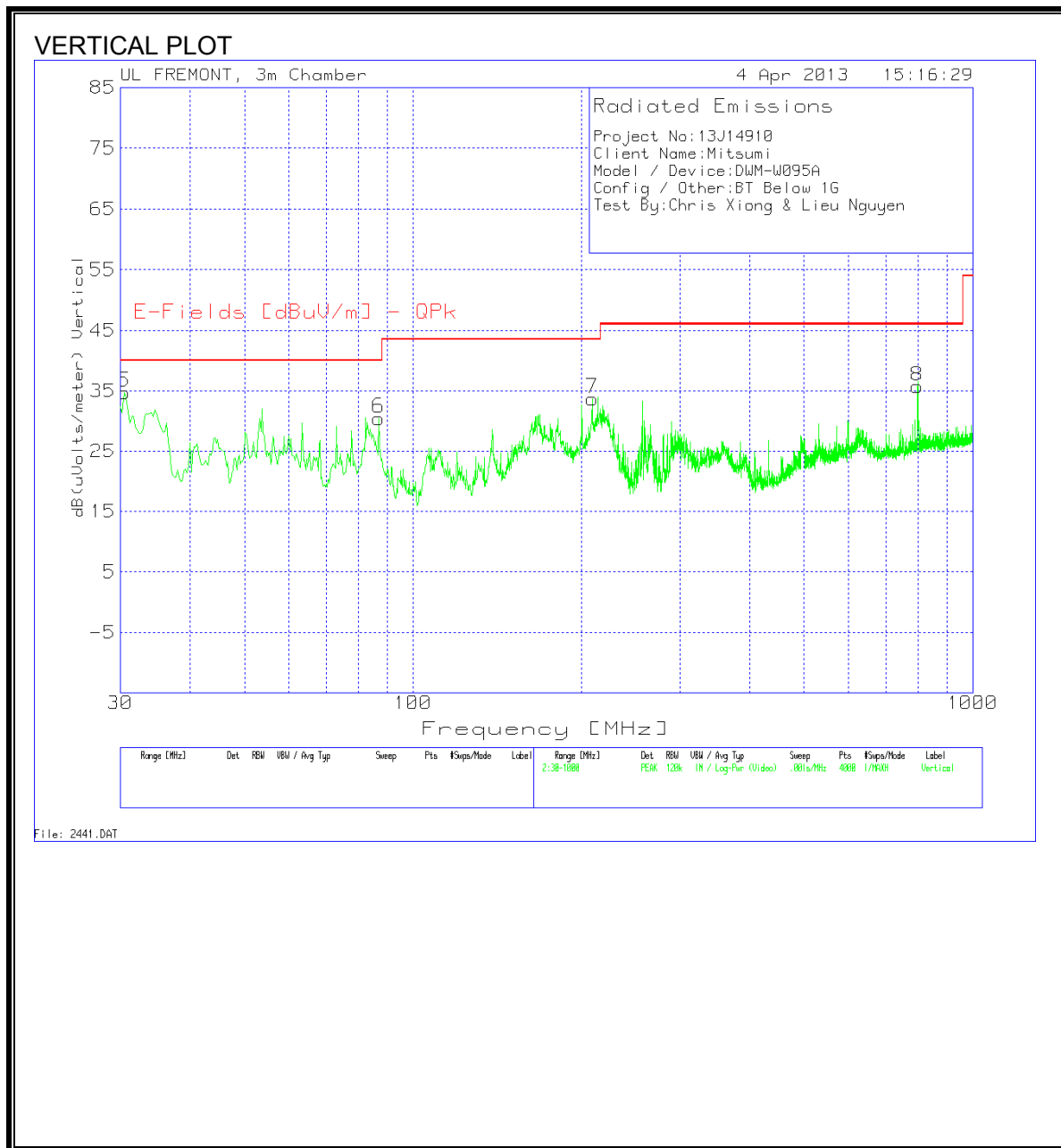

EMISSIONS DATA

Project No:13J14910										
Client Name:Mitsumi										
Model / Device:DWM-W095A										
Config / Other:BT Below 1G										
Test By:Chris Xiong & Lieu Nguyen										
Horizontal 30 - 1000MHz										
Marker No.	Test Frequency (MHz)	Meter Reading (dBµV)	Detector	T130 Ant Factor [dB/m]	T64 preamp/ cable loss [dB]	dB(uVolts /meter)	E-Fields [dBuV/m] - QPk	Margin (dB)	Height [cm]	Polarity
1	461.5688	47.46	PK	17.2	-25	39.66	46.02	-6.36	101	Horz
2	256.3253	52.44	PK	11.7	-26	38.14	46.02	-7.88	101	Horz
3	607.2021	47.55	PK	18.8	-23.7	42.65	46.02	-3.37	101	Horz
4	34.604	43.1	PK	17.6	-27.6	33.1	40	-6.9	101	Horz
Vertical 30 - 1000MHz										
Marker No.	Test Frequency (MHz)	Meter Reading (dBµV)	Detector	T130 Ant Factor [dB/m]	T64 preamp/ cable loss [dB]	dB(uVolts /meter)	E-Fields [dBuV/m] - QPk	Margin (dB)	Height [cm]	Polarity
5	30.4846	42	PK	20.5	-27.7	34.8	40	-5.2	100	Vert
6	86.9448	50.39	PK	7.3	-27.2	30.49	40	-9.51	100	Vert
7	209.3155	49.56	PK	10.5	-26.3	33.76	43.52	-9.76	100	Vert
8	796.4527	37.33	PK	21.3	-22.9	35.73	46.02	-10.29	100	Vert

9. AC POWER LINE CONDUCTED EMISSIONS

LIMITS

FCC §15.207 (a)

RSS-Gen 7.2.2

Frequency of Emission (MHz)	Conducted Limit (dBuV)	
	Quasi-peak	Average
0.15-0.5	66 to 56*	56 to 46*
0.5-5	56	46
5-30	60	50

*Decreases with the logarithm of the frequency.

TEST PROCEDURE

The EUT is placed on a non-conducting table 40 cm from the vertical ground plane and 80 cm above the horizontal ground plane. The EUT is configured in accordance with ANSI C63.4.

The receiver is set to a resolution bandwidth of 9 kHz. Peak detection is used unless otherwise noted as quasi-peak or average.

Line conducted data is recorded for both NEUTRAL and HOT lines.

RESULTS

6 WORST EMISSIONS

Project No:13J14910									
Client Name:MITSUMI									
Model/Device:DWM_W095A									
Test Volt/Freq:115VAC/ 60Hz									
Test By:Thanh Nguyen									
Line-L1 .15 - 30MHz									
Test Frequency (MHz)	Meter Reading (dBµV)	Detector	T24 IL L1.TXT (dB)	LC Cables 1&3.TXT (dB)	dB(uVolts)	CFR 47 Part 15 Class B QP	Margin (dB)	CFR 47 Part 15 Class B Avg	Margin (dB)
0.186	57.82	PK	0.1	0	57.92	64.2	-6.28	-	-
0.186	50.2	Av	0.1	0	50.3	-	-	54.2	-3.9
15.369	38.04	PK	0.2	0.2	38.44	60	-21.56	-	-
15.369	22.27	Av	0.2	0.2	22.67	-	-	50	-27.33
29.3955	54.63	PK	0.5	0.3	55.43	60	-4.57	-	-
29.3955	45.19	Av	0.5	0.3	45.99	-	-	50	-4.01
Line-L2 .15 - 30MHz									
Test Frequency (MHz)	Meter Reading (dBµV)	Detector	T24 IL L1.TXT (dB)	LC Cables 1&3.TXT (dB)	dB(uVolts)	CFR 47 Part 15 Class B QP	Margin (dB)	CFR 47 Part 15 Class B Avg	Margin (dB)
0.186	56.75	PK	0.1	0	56.85	64.2	-7.35	-	-
0.186	52.66	Av	0.1	0	52.76	-	-	54.2	-1.44
15.5085	38.9	PK	0.2	0.2	39.3	60	-20.7	-	-
15.5085	27.99	Av	0.2	0.2	28.39	-	-	50	-21.61
29.895	53.75	PK	0.5	0.3	54.55	60	-5.45	-	-
29.895	44.48	Av	0.5	0.3	45.28	-	-	50	-4.72

LINE 1 RESULTS

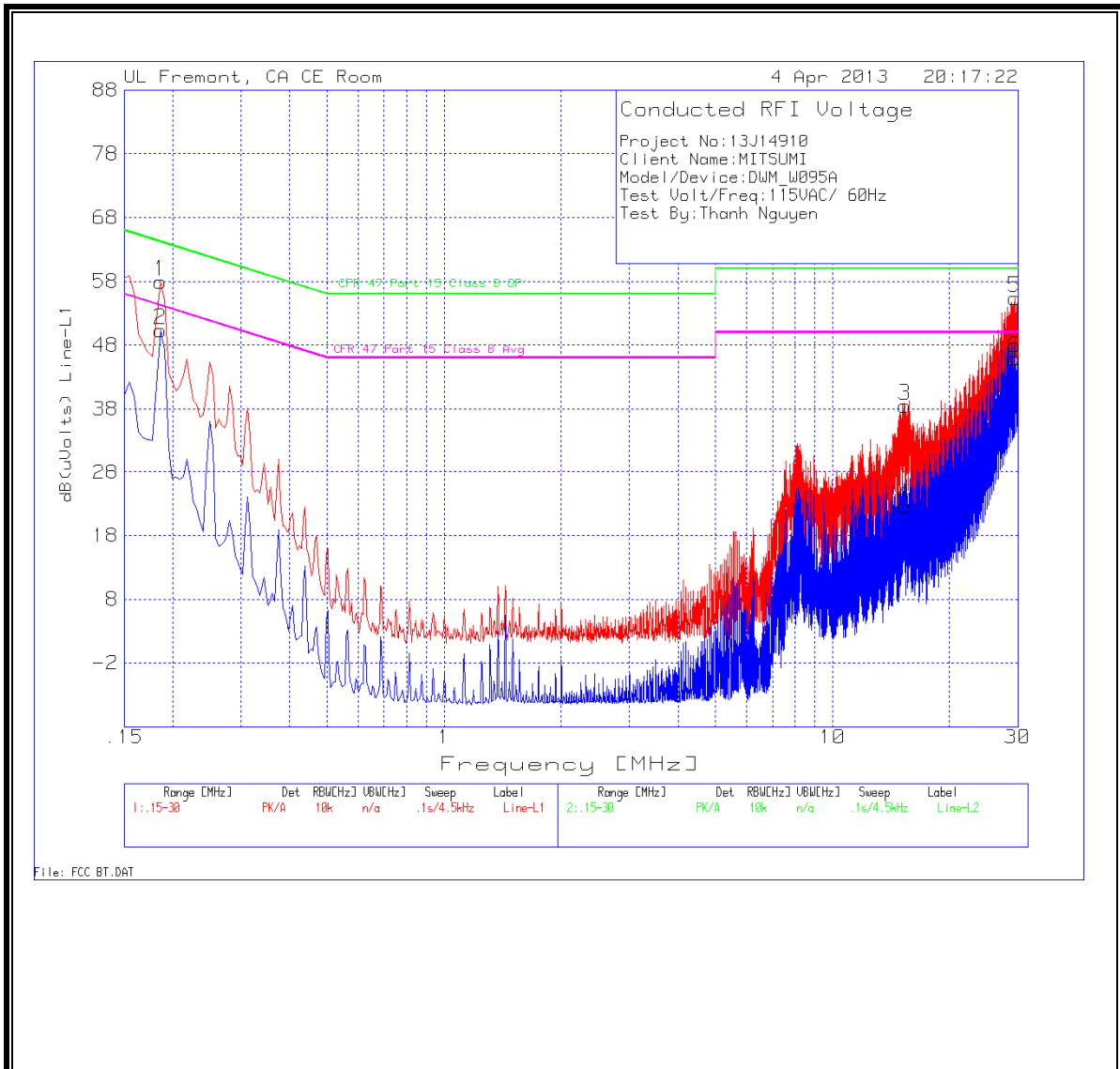

LINE 2 RESULTS

