

# FCC 47 CFR PART 15 SUBPART B & ICES-003 Issue 6 TEST REPORT

For

Tablet

HP Elite x2 G4 Tablet, HP Elite x2 G4,  
HP Elite x2 G4 with Collaboration Keyboard,  
HP Elite x2 G4 with Folio Keyboard

Issued for

**COMPAL ELECTRONICS, INC.**

**No.581 & 581-1, Ruiguang Rd., Neihu District, Taipei City 11492, Taiwan**

Issued By:

**Compliance Certification Services Inc.**

Wugu Laboratory

No.11, Wugong 6th Rd., Wugu Dist.,  
New Taipei City 24891, Taiwan. (R.O.C.)

**Issued Date: June 10, 2019**

**Note:** This document may be altered or revised by Compliance Certification Services Inc. personnel only, and shall be noted in the revision section of the document. The client should not use it to claim product endorsement by TAF, A2LA, NIST or any government agencies. The test results in the report only apply to the tested sample.

Unless otherwise stated the results shown in this test report refer only to the sample(s) tested and such sample(s) are retained for 90 days only.  
除非另有說明，此報告結果僅對測試之樣品負責，同時此樣品僅保留90天。本報告未經本公司書面許可，不可部分複製。

This document is issued by the Company subject to its General Conditions of Service printed overleaf, available on request or accessible at [www.sgs.com/terms\\_and\\_conditions.htm](http://www.sgs.com/terms_and_conditions.htm) and for electronic format documents, subject to Terms and Conditions for Electronic Documents at [www.sgs.com/terms\\_e-document.htm](http://www.sgs.com/terms_e-document.htm). Attention is drawn to the limitation of liability, indemnification and jurisdiction issues defined therein. Any holder of this document is advised that information contained hereon reflects the Company's findings at the time of its intervention only and within the limits of Client's instructions, if any. The Company's sole responsibility is to its Client and this document does not exonerate parties to a transaction from exercising all their rights and obligations under the transaction documents. This document cannot be reproduced except in full, without prior written approval of the Company. Any unauthorized alteration, forgery or falsification of the content or appearance of this document is unlawful and offenders may be prosecuted to the fullest extent of the law.



**Report No.:** T190308L01-F

Page: 2 / 43

Rev.: 00

**Revision History**

Rev.	Issue Date	Revisions	Effect Page	Revised By
00	June 10, 2019	Initial Issue	ALL	Milly Wang



Report No.: T190308L01-F

## TABLE OF CONTENTS

<b>1</b>	<b>TEST RESULT CERTIFICATION</b> .....	<b>4</b>
<b>2</b>	<b>EUT DESCRIPTION</b> .....	<b>5</b>
<b>3</b>	<b>TEST METHODOLOGY</b> .....	<b>9</b>
3.1.	DECISION OF FINAL TEST MODE .....	9
3.2.	EUT SYSTEM OPERATION .....	10
<b>4</b>	<b>SETUP OF EQUIPMENT UNDER TEST</b> .....	<b>11</b>
4.1.	DESCRIPTION OF SUPPORT UNITS .....	11
4.2.	CONFIGURATION OF SYSTEM UNDER TEST .....	12
<b>5</b>	<b>FACILITIES AND ACCREDITATIONS</b> .....	<b>13</b>
5.1.	FACILITIES .....	13
5.2.	ACCREDITATIONS .....	13
5.3.	MEASUREMENT UNCERTAINTY .....	14
<b>6</b>	<b>CONDUCTED EMISSION MEASUREMENT</b> .....	<b>15</b>
6.1.	LIMITS OF CONDUCTED EMISSION MEASUREMENT .....	15
6.2.	TEST INSTRUMENTS .....	15
6.3.	TEST PROCEDURES .....	16
6.4.	TEST SETUP .....	17
6.5.	DATA SAMPLE: .....	17
6.6.	TEST RESULTS .....	18
<b>7</b>	<b>RADIATED EMISSION MEASUREMENT</b> .....	<b>22</b>
7.1.	LIMITS OF RADIATED EMISSION MEASUREMENT .....	22
7.2.	TEST INSTRUMENTS .....	24
7.3.	TEST PROCEDURES .....	26
7.4.	TEST SETUP .....	28
7.5.	DATA SAMPLE: .....	29
7.6.	TEST RESULTS .....	30
<b>8</b>	<b>PHOTOGRAPHS OF THE TEST CONFIGURATION</b> .....	<b>41</b>
	<b>APPENDIX 1 - PHOTOGRAPHS OF EUT</b>	

Report No.: T190308L01-F

# 1 TEST RESULT CERTIFICATION

<b>Product:</b>	Tablet
<b>Brand:</b>	 , HP, HP Inc.
<b>Model:</b>	HSN-C04C, HP Elite x2 G4 Tablet, HP Elite x2 G4, HP Elite x2 G4 with Collaboration Keyboard, HP Elite x2 G4 with Folio Keyboard
<b>Applicant:</b>	<b>COMPAL ELECTRONICS, INC.</b> No.581, Ruiguang Rd., Neihu District, Taipei City 11492, Taiwan
<b>Tested:</b>	March 31 ~ April 17, 2019
<b>Test Voltage:</b>	120Vac, 60Hz

EMISSION			
Standard	Item	Result	Remarks
FCC 47 CFR Part 15 Subpart B, ICES-003 Issue 6-2016 ANSI C63.4-2014	Conducted (Power Port)	PASS	Meet Class B limit
	Radiated	PASS	Meet Class B limit

Note: 1. The statements of test result on the above are decided by the request of test standard only; the measurement uncertainties are not factored into this compliance determination.  
2. The information of measurement uncertainty is available upon the customer's request.

Deviation from Applicable Standard
None

Statements of Conformity
Determination of compliance is based on the results of the compliance measurement, not taking into account measurement instrumentation uncertainty.

The above equipment has been tested by Compliance Certification Services Inc., and found compliance with the requirements set forth in the technical standards mentioned above. The results of testing in this report apply only to the product/system, which was tested. Other similar equipment will not necessarily produce the same results due to production tolerance and measurement uncertainties.

Approved by:

Tested by:





Hex Chiang  
Supervisor

Rex Kuo  
Engineer

Report No.: T190308L01-F

## 2 EUT DESCRIPTION

<b>Product</b>	Tablet
<b>Brand Name</b>	 , HP, HP Inc.
<b>Model</b>	HSN-C04C, HP Elite x2 G4 Tablet, HP Elite x2 G4, HP Elite x2 G4 with Collaboration Keyboard, HP Elite x2 G4 with Folio Keyboard
<b>Applicant</b>	COMPAL ELECTRONICS, INC.
<b>Housing material</b>	Plastic w/ metal plate
<b>Identify Number</b>	T190308L01
<b>Received Date</b>	March 08, 2019
<b>Manufacturer</b>	<ol style="list-style-type: none"> <li>1. <b>COMPAL INFORMATION (KUNSHAN) CO., LTD.</b> NO. 15, THIRD AVENUE, A ZONE, KUNSHAN COMPREHENSIVE FREETRADE ZONE, KUNSHAN, JIANGSU CHINA</li> <li>2. <b>COMPAL ELECTRONICS TECHNOLOGY (KUNSHAN) CO., LTD.</b> NO. 25, THIRD AVENUE, A ZONE, KUNSHAN COMPREHENSIVE FREETRADE ZONE, KUNSHAN, JIANGSU CHINA</li> <li>3. <b>ECMMS S A DE C V BLVD OSCAR FLORES SANCHEZ</b> 8951, COL PUENTE ALTO, 32690 JUAREZ CHIH MEXICO</li> <li>4. <b>COMPAL DIGITAL TECHNOLOGY (KUNSHAN) CO., LTD.</b> NO.9, SECOND AVENUE, A ZONE, KUNSHAN COMPREHENSIVE FREE TRADE ZONE, KUNSHAN, JIANGSU CHINA</li> <li>5. <b>COMPAL ELETÔNICA DO BRASIL INDÚSTRIA E COMÉRCIO LTDA</b> RUA KANEBO 175, GALPÕES C1, C2, C3, C4, C5 C6 E C12, BAIRRO DISTRITO INDUSTRIAL JUNDIAÍ BUSINESS PARK, CEP 13213-090, JUNDIAÍ - SÃO PAULO BRASIL</li> <li>6. <b>COMPAL (VIETNAM) CO., LTD.</b> Ba Thien 1 Industrial Zone, Binh Xuyen District, Vinh Phuc Province, Vietnam</li> <li>7. <b>COMPAL ELECTRONICS (CHENGDU) CO., LTD.</b> NO. 88, SEC.1, ZONGBAO AVENUE, CHENGDU HI-TECH COMPREHENSIVE BONDED ZONE (SHUANGLIU), SHUANGLIU COUNTY, CHENGDU CITY, SICHUAN CHINA</li> <li>8. <b>COMPAL ELECTRONICS (CHONGQING) CO., LTD.</b> NO. D01, ZONE D, AIR PORT SECTION OF LIANGLU CUNTAN FREETRADE PORT AREA, YUBEI DISTRICT, CHONGQING CHINA</li> <li>9. <b>FOXCONN CMSG INDUSTRIA DE ELECTRONICOS LTDA.</b> AV. MARGINAL RODOVIA DOS BANDEIRANTES, 800 BAIRRO ENGORDADOURO, JUNDIAI - SP - BRAZIL</li> </ol>

Report No.: T190308L01-F

<b>EUT Power Rating</b>	100-240V, 1.7A or 100-240V, 1.6A form Adapter	
<b>AC Power Cord Type</b>	Non-Shielded, 1.8m (Detachable)	
<b>DC Power Cable Type</b>	Non-Shielded, 1.6m (Non-Detachable)	
<b>Power Adapter</b>	Chicony(hp)	TPN-CA06
	Chicony(hp)	TPN-CA10
	Acbel(hp)	TPN-AA03
	Lite-On(hp)	TPN-LA12
	Artesyn	TPN-TA02
<b>Power Adaptor Rating</b>	<b>For TPN-CA06</b> I/P: 100-240V, 1.7A, 50-60Hz O/P:5Vdc, 3A / 9Vdc, 3A / 10Vdc, 5A / 12Vdc, 5A / 15Vdc, 4.33A / 20Vdc, 3.25A	
	<b>For TPN-CA10</b> I/P: 100-240V, 1.6A, 50-60Hz O/P:5Vdc, 3A / 9Vdc, 3A / 12Vdc, 5A / 15Vdc, 4.33A / 20Vdc, 3.25A	
	<b>For TPN-AA03</b> I/P: 100-240V, 1.7A, 50-60Hz O/P:5Vdc, 3A / 9Vdc, 3A / 10Vdc, 5A / 12Vdc, 5A / 15Vdc, 4.33A / 20Vdc, 3.25A	
	<b>For TPN-LA12</b> I/P: 100-240V, 1.6A, 50-60Hz O/P:5Vdc, 3A / 9Vdc, 3A / 12Vdc, 5A / 15Vdc, 4.33A / 20Vdc, 3.25A	
	<b>For TPN-TA02</b> I/P: 100-240V, 1.6A, 50/60Hz O/P: 5Vdc, 3A / 9Vdc, 3A / 12Vdc, 5A / 15Vdc, 4.33A / 20Vdc, 3.25A	
<b>Memory (On board)</b>	LPDDR3 2133 MHz (8GB / 16GB)	
<b>Main Board</b>	Compal	LA-G931
<b>CPU</b>	Intel	i5-8365U (1.6GHz)
		i7-8665U (1.9GHz)
		i7-8565U (1.8GHz)
		i5-8265U (1.6GHz)
<b>13" LCD Panel</b>	AUO	B130KAN01.0
<b>12.3" LCD Panel</b>	Sharp	LQ123N1JX33
<b>Touch Panel</b>	Laibao	ST123FN014AKM
		ST130FN002AKM
	TPK	T08ALO13003HA
		T08ALO12302HA
<b>Touch Control Board</b>	Wacom	CCB-142-01X

Report No.: T190308L01-F

<b>M.2 SSD</b>	Samsung	MZVLB256HAHQ-000H1 (256GB)
	Western Digital	SDAPNTW-1T00-1006 (1TB)
		SDAQNTW-512G-1006 (512GB)
	Toshiba	KBG30ZMV256G (256GB)
		KBG30ZMV512G (512GB)
Hynix	HFM512GDJTNG-8310A (512GB)	
<b>eMMC (on board)</b>	Hynix	H26M62002JPR (32GB)
	Samsung	KLMBG2JETD-B041 (32GB)
	SanDisk	SDINBDA4-32G-V (32GB)
<b>WLAN (On board)</b>	Intel	9560D2W
		AX200D2WL
<b>WWAN</b>	Fibocom	L850-GL
		L860-GL
<b>GPS Module</b>	Azurewave	GPS-294NF
<b>Rear Camera (8M)</b>	Luxvisions	7BA805T2A
	TFC	YHCY
<b>Front Camera (2M)</b>	Luxvisions	8BF206T2
	TFC	YHCB
<b>Battery Pack</b>	Dynapack	HSTNN-DB9E
<b>Keyboard</b>	Primax	HSN-P01K
	COSMO	HSN-C01K
<b>HP ACTIVE PEN G2</b>	Wacom	HSN-W001P
<b>HP USB-C to DisplayPort Adapter</b>	HP	KSC0044
<b>USB-C to RJ45 Adapter</b>	HP	RTL8153-03
<b>HP USB-C to HDMI 2.0 Adapter</b>	HP	KSC0094
<b>HP USB-C to VGA Adapter</b>	HP	KSC0021
<b>HP USB-C to USB-A HUB</b>	HP	HSA-B003
<b>HP USB-C to USB3.0 Adapter</b>	HP	KSC0003
<b>HP USB-C Mini Dock</b>	HP	HSA-Q001PR
<b>HP Elite Thunderbolt 3 Dock</b>	HP	HSTNN-CX01



Report No.: T190308L01-F

Page: 8 / 43

Rev.: 00

HP Thunderbolt Dock 120W G2	HP	HSN-IX01
HP USB-C Dock G4	HP	HSTNH-U601

**Note:**

1. Client consigns only one sample to test (model number: HSN-C04C). Therefore, the testing Lab. just guarantees the unit, which has been tested.
2. Difference of the model numbers (list on this report) is just for marketing purpose only.

**I/O Port**

I/O PORT TYPES	Q'TY	TESTED WITH
1).USB 3.1 Type C Port (Tablet)	3	3
2).Audio Port (Tablet)	1	1



Report No.: T190308L01-F

### 3 TEST METHODOLOGY

#### 3.1. DECISION OF FINAL TEST MODE

1. The following test modes were scanned during the preliminary test:

Pre-test mode																			
Mode	CPU	13" LCD Panel / 12.3" LCD Panel	Touch Panel	Touch Control Board	Memory (On board)	Main Board	M.2 SSD	eMMC (on board)	WLAN (On board)	WWAN	GPS Module	Rear Camera (RM)	Front Camera (2M)	Battery Pack	Keyboard	HP ACTIVE PEN G2	(USB Type C Port 1)	(USB Type C Port 2)	AC Power Adapter (USB Type C Port 3)
1	Intel i5-8265U (1.6GHz)	AUO B130KA N01.0	Laibao ST123FN 0144KM	Wacom CCB-1 42-01X	8GB LPDDR3 2133 MHz	Compal LA-G931	Samsung MZVLB256HAHQ-000H1 (256GB)	Hynix H26M6200 2JPR (32GB)	Intel 9560D2W	Fibocom L850-GL	Azurewave GPS-294NF	Luxvisions 7BA805T2A	Luxvisions 8BF206T2	Dynapack HSTNN-D 89E	Primax HSN-P01K	Wacom HSN-W 001P	HP USB-C to DisplayPort Adapter(HP) K5C0044	HP USB-C Dock G4(HP) HSTNH-U601	Chincony(hp) TPN-CA06
2	Intel i7-8665U (1.9GHz)	Sharp LO123N 1JX33	Laibao ST130FN 002AKM	Wacom CCB-1 42-01X	16GB LPDDR3 2133 MHz	Compal LA-G931	Western Digital SDAPNT W-1T00-1 006 (1TB)	Samsung KLMBG2J ETD-B041 (32GB)	Intel AX200D2 WL	Fibocom L860-GL	Azurewave GPS-294NF	TFC YHCY	TFC YHCB	Dynapack HSTNN-D 89E	COSMO HSN-P09K	Wacom HSN-W 001P	USB-C to RJ45 Adapter(HP) RTL8153-03	HP Thunderbolt Dock 120W G2(HP) HSN-1X01	Acbel(hp) TPN-AA03
3	Intel i7-8665U (1.8GHz)	AUO B130KA N01.0	TPK T08AL01 3003HA	Wacom CCB-1 42-01X	8GB LPDDR3 2133 MHz	Compal LA-G931	Western Digital SDAGNT W-512G-1 006 (512GB)	SanDisk SDINBD44 -32G-V (32GB)	Intel 9560D2W	Fibocom L860-GL	Azurewave GPS-294NF	TFC YHCY	Luxvisions 8BF206T2	Dynapack HSTNN-D 89E	NA	Wacom HSN-W 001P	HP USB-C to HDMI 2.0 Adapter(HP) K5C0044	HP Elite Thunderbolt 3 Dock(HP) HSTNN-CX01	Lite-On(hp) TPN-LA12
4	Intel i5-8265U (1.6GHz)	AUO B130KA N01.0	TPK T08AL01 2302HA	Wacom CCB-1 42-01X	8GB LPDDR3 2133 MHz	Compal LA-G931	Toshiba KB3002 MV256G (256GB)	Samsung KLMBG2J ETD-B041 (32GB)	Intel 9560D2W	Fibocom L860-GL	Azurewave GPS-294NF	TFC YHCY	Luxvisions 8BF206T2	Dynapack HSTNN-D 89E	Primax HSN-P01K	Wacom HSN-W 001P	HP USB-C to VGA Adapter(HP) K5C0021	HP USB-C Mini Dock(HP) HSA-0001PR	Artesyn(hp) TPN-TA02
5	Intel i5-8265U (1.6GHz)	AUO B130KA N01.0	Laibao ST130FN 002AKM	Wacom CCB-1 42-01X	8GB LPDDR3 2133 MHz	Compal LA-G931	Toshiba KB3002 MV512G (512GB)	Samsung KLMBG2J ETD-B041 (32GB)	Intel 9560D2W	Fibocom L860-GL	Azurewave GPS-294NF	TFC YHCY	Luxvisions 8BF206T2	Dynapack HSTNN-D 89E	Primax HSN-P01K	Wacom HSN-W 001P	HP USB-C to USB-A Adapter(HP) K5C0003	HP USB-C to USB3.0 Adapter(HP) K5C0003	Chincony(hp) TPN-CA10
6	Intel i5-8265U (1.6GHz)	AUO B130KA N01.0	Laibao ST130FN 002AKM	Wacom CCB-1 42-01X	8GB LPDDR3 2133 MHz	Compal LA-G931	Hynix HFM512G DJTNG-8 310A (512GB)	Samsung KLMBG2J ETD-B041 (32GB)	Intel 9560D2W	Fibocom L860-GL	Azurewave GPS-294NF	TFC YHCY	Luxvisions 8BF206T2	Dynapack HSTNN-D 89E	Primax HSN-P01K	Wacom HSN-W 001P	HP USB-C to Mini Dock(HP) HSA-8003	HP USB-C to USB-A HUB(HP) HSA-B003	Artesyn(hp) TPN-TA02
7	Intel i5-8265U (1.6GHz)	AUO B130KA N01.0	Laibao ST130FN 002AKM	Wacom CCB-1 42-01X	8GB LPDDR3 2133 MHz	Compal LA-G931	Hynix HFM512G DJTNG-8 310A (512GB)	Samsung KLMBG2J ETD-B041 (32GB)	Intel 9560D2W	Fibocom L860-GL	Azurewave GPS-294NF	TFC YHCY	Luxvisions 8BF206T2	Dynapack HSTNN-D 89E	Primax HSN-P01K	Wacom HSN-W 001P	HP USB-C to Mini Dock(HP) HSA-0001PR	HP USB-C to VGA Adapter(HP) K5C0021	Artesyn(hp) TPN-TA02
8	Intel i5-8265U (1.6GHz)	AUO B130KA N01.0	Laibao ST130FN 002AKM	Wacom CCB-1 42-01X	8GB LPDDR3 2133 MHz	Compal LA-G931	Hynix HFM512G DJTNG-8 310A (512GB)	Samsung KLMBG2J ETD-B041 (32GB)	Intel 9560D2W	Fibocom L860-GL	Azurewave GPS-294NF	TFC YHCY	Luxvisions 8BF206T2	Dynapack HSTNN-D 89E	Primax HSN-P01K	Wacom HSN-W 001P	HP Elite Thunderbolt 3 Dock(HP) HSTNN-CX01	HP USB-C to HDMI 2.0 Adapter(HP) K5C0094	Artesyn(hp) TPN-TA02
9	Intel i5-8265U (1.6GHz)	AUO B130KA N01.0	Laibao ST130FN 002AKM	Wacom CCB-1 42-01X	8GB LPDDR3 2133 MHz	Compal LA-G931	Hynix HFM512G DJTNG-8 310A (512GB)	Samsung KLMBG2J ETD-B041 (32GB)	Intel 9560D2W	Fibocom L860-GL	Azurewave GPS-294NF	TFC YHCY	Luxvisions 8BF206T2	Dynapack HSTNN-D 89E	Primax HSN-P01K	Wacom HSN-W 001P	HP Thunderbolt Dock 120W G2(HP) HSN-1X01	USB-C to RJ45 Adapter(HP) RTL8153-03	Artesyn(hp) TPN-TA02
10	Intel i5-8265U (1.6GHz)	AUO B130KA N01.0	Laibao ST130FN 002AKM	Wacom CCB-1 42-01X	8GB LPDDR3 2133 MHz	Compal LA-G931	Hynix HFM512G DJTNG-8 310A (512GB)	Samsung KLMBG2J ETD-B041 (32GB)	Intel 9560D2W	Fibocom L860-GL	Azurewave GPS-294NF	TFC YHCY	Luxvisions 8BF206T2	Dynapack HSTNN-D 89E	Primax HSN-P01K	Wacom HSN-W 001P	HP USB-C to DisplayPort Adapter(HP) K5C0044	HP USB-C Dock G4(HP) HSTNH-U601	Artesyn(hp) TPN-TA02
11	Intel i5-8265U (1.6GHz)	Sharp LO123N 1JX33	TPK T08AL01 3003HA	Wacom CCB-1 42-01X	8GB LPDDR3 2133 MHz	Compal LA-G931	Samsung MZVLB256HAHQ-000H1 (256GB)	N/A	Intel 9560D2W	Fibocom L860-GL	Azurewave GPS-294NF	Luxvisions 7BA805T2A	Luxvisions 8BF206T2	Dynapack HSTNN-D 89E	Primax HSN-P01K	Wacom HSN-W 001P	N/A	HP Elite Thunderbolt 3 Dock(HP) HSTNN-CX01	Chincony(hp) TPN-CA06
12	Intel i7-8665U (1.9GHz)	AUO B130KA N01.0	TPK T08AL01 2302HA	Wacom CCB-1 42-01X	16GB LPDDR3 2133 MHz	Compal LA-G931	Western Digital SDAPNT W-1T00-1 006 (1TB)	SanDisk SDINBD44 -32G-V (32GB)	Intel 9560D2W	Fibocom L860-GL	Azurewave GPS-294NF	TFC YHCY	TFC YHCB	Dynapack HSTNN-D 89E	COSMO HSN-P09K	Wacom HSN-W 001P	N/A	HP Elite Thunderbolt 3 Dock(HP) HSTNN-CX01	Acbel(hp) TPN-AA03
13	Intel i5-8265U (1.6GHz)	AUO B130KA N01.0	Laibao ST123FN 0144KM	Wacom CCB-1 42-01X	8GB LPDDR3 2133 MHz	Compal LA-G931	Western Digital SDAGNT W-512G-1 006 (512GB)	N/A	Intel 9560D2W	Fibocom L860-GL	Azurewave GPS-294NF	TFC YHCY	Luxvisions 8BF206T2	Dynapack HSTNN-D 89E	Primax HSN-P01K	Wacom HSN-W 001P	N/A	HP Elite Thunderbolt 3 Dock(HP) HSTNN-CX01	Lite-On(hp) TPN-LA12
14	Intel i7-8665U (1.8GHz)	Sharp LO123N 1JX33	Laibao ST130FN 002AKM	Wacom CCB-1 42-01X	16GB LPDDR3 2133 MHz	Compal LA-G931	Toshiba KB3002 MV512G (512GB)	Hynix H26M6200 2JPR (32GB)	Intel AX200D2 WL	Fibocom L860-GL	Azurewave GPS-294NF	Luxvisions 7BA805T2A	TFC YHCB	Dynapack HSTNN-D 89E	COSMO HSN-P09K	Wacom HSN-W 001P	N/A	HP Elite Thunderbolt 3 Dock(HP) HSTNN-CX01	Acbel(hp) TPN-AA03
15	Intel i5-8265U (1.6GHz)	AUO B130KA N01.0	TPK T08AL01 2302HA	Wacom CCB-1 42-01X	16GB LPDDR3 2133 MHz	Compal LA-G931	Toshiba KB3002 MV256G (256GB)	N/A	Intel 9560D2W	N/A	Azurewave GPS-294NF	Luxvisions 7BA805T2A	Luxvisions 8BF206T2	Dynapack HSTNN-D 89E	Primax HSN-P01K	Wacom HSN-W 001P	N/A	HP Elite Thunderbolt 3 Dock(HP) HSTNN-CX01	Lite-On(hp) TPN-LA12
16	Intel i5-8265U (1.6GHz)	AUO B130KA N01.0	Laibao ST130FN 002AKM	Wacom CCB-1 42-01X	8GB LPDDR3 2133 MHz	Compal LA-G931	Hynix HFM512G DJTNG-8 310A (512GB)	Samsung KLMBG2J ETD-B041 (32GB)	Intel 9560D2W	Fibocom L860-GL	Azurewave GPS-294NF	TFC YHCY	Luxvisions 8BF206T2	Dynapack HSTNN-D 89E	Primax HSN-P01K	Wacom HSN-W 001P	N/A	HP Elite Thunderbolt 3 Dock(HP) HSTNN-CX01	Artesyn(hp) TPN-TA02
17	Intel i5-8265U (1.6GHz)	AUO B130KA N01.0	Laibao ST130FN 002AKM	Wacom CCB-1 42-01X	8GB LPDDR3 2133 MHz	Compal LA-G931	Hynix HFM512G DJTNG-8 310A (512GB)	Samsung KLMBG2J ETD-B041 (32GB)	Intel 9560D2W	Fibocom L860-GL	Azurewave GPS-294NF	TFC YHCY	Luxvisions 8BF206T2	Dynapack HSTNN-D 89E	COSMO HSN-P09K	Wacom HSN-W 001P	N/A	HP Elite Thunderbolt 3 Dock(HP) HSTNN-CX01	Artesyn(hp) TPN-TA02

**Report No.:** T190308L01-F

- After the preliminary scan, the following test modes were found to produce the highest emission level.

Final Test Mode		
Emission	Conducted Emission	<b>Mode 16</b> <b>Windows 10, EUT (1920*1280) + Type-C (3840*2160) + VGA (1920*1080)</b> <b>Mode 17</b> <b>Windows 10, EUT (1920*1280) + Type-C (3840*2160) + VGA (1920*1080)</b>
	Radiated Emission	<b>Mode 16</b> <b>Windows 10, EUT (1920*1280) + Type-C (3840*2160) + VGA (1920*1080)</b> <b>Mode 17</b> <b>Windows 10, EUT (1920*1280) + Type-C (3840*2160) + VGA (1920*1080)</b>

Then, the above highest emission mode of the configuration of the EUT and cable was chosen for all final test items.

### 3.2. EUT SYSTEM OPERATION

- Setup the EUT and simulators as shown on 4.2.
- Turn on the power of all equipment.
- The EUT will reads/writes disk through “WINEMC” test software.
- The EUT communicates with Notebook PC by Bluetooth radio.
- The EUT execute the WINEMC software to send “H” Pattern to display on the screen.
- Executed AMCAP2 software to turn-on the Camera.
- The EUT transfers data to another Notebook PC via LAN Port.
- Setup the condition for test mode, and begin the test.

**Note:** Test program is self-repeating throughout the test.

Report No.: T190308L01-F

## 4 SETUP OF EQUIPMENT UNDER TEST

### 4.1. DESCRIPTION OF SUPPORT UNITS

The EUT has been tested as an independent unit together with other necessary accessories or support units. The following support units or accessories were used to form a representative test configuration during the tests.

#### Peripherals Devices:

No	PRODUCT	MANUFACTURER	MODEL NO.	SERIAL NO.
1	LCD Monitor	DELL	U2713HMT	CN-0C34G2-74445-1AP-034L
2	LCD Monitor	DELL	UP3214Q	CN-09637J-74445-3A7-206P
3	LCD Monitor	DELL	P2815QF	CV-0WJJGR-72872-4A7-A1GM
4	LCD Monitor	DELL	P2815QF	CN-0WJJGR-72872-454-AUYM
5	Earphone	APPLE	N/A	N/A
6	Earphone	SENIC	ST-908	N/A
7	Mouse	DELL	MS111-L	CN-0HRG26-44751-21U-05YA
8	HDD	WD	WDBPGC5005ABK-PESN	WXD1E849K9YF
	HDD	WD	WDBPGC5006ABK-PESN	WX21E54RD766
	HDD	WD	WDBPGC5007ABK-PESN	WX91A744F4NL
	HDD	WD	WDBPGC5008ABK-PESN	WX41A946S312
9	Notebook PC (Remote)	HP	Pavilion dv6	CNF9491GLJ
10	Pen	HP	N/A	N/A
11	Wireless AP (Remote)	D-Link	DIR-868L	R3X81D7000137

No.	Cable Name	Unit	Shielded	Length	With Core
(A)	DC Cable	1	<input type="checkbox"/> Shielded, <input checked="" type="checkbox"/> Non	1.8 m	<input type="checkbox"/> With Corex____, <input checked="" type="checkbox"/> Non
(B)	LAN Cable	1	<input type="checkbox"/> Shielded, <input checked="" type="checkbox"/> Non	10 m	<input type="checkbox"/> With Corex____, <input checked="" type="checkbox"/> Non
(C)	USB HDD Cable	4	<input checked="" type="checkbox"/> Shielded, <input type="checkbox"/> Non	0.6 m	<input type="checkbox"/> With Corex____, <input checked="" type="checkbox"/> Non
(D)	USB Mouse Cable	1	<input checked="" type="checkbox"/> Shielded, <input type="checkbox"/> Non	1.8 m	<input type="checkbox"/> With Corex____, <input checked="" type="checkbox"/> Non
(E)	Earphone Cable	1	<input type="checkbox"/> Shielded, <input checked="" type="checkbox"/> Non	1 m	<input type="checkbox"/> With Corex____, <input checked="" type="checkbox"/> Non
(F)	Type-C Cable	1	<input checked="" type="checkbox"/> Shielded, <input type="checkbox"/> Non	0.3 m	<input type="checkbox"/> With Corex____, <input checked="" type="checkbox"/> Non
(G)	Type-C Cable	1	<input checked="" type="checkbox"/> Shielded, <input type="checkbox"/> Non	1 m	<input type="checkbox"/> With Corex____, <input checked="" type="checkbox"/> Non
(H)	Earphone Cable	1	<input type="checkbox"/> Shielded, <input checked="" type="checkbox"/> Non	1 m	<input type="checkbox"/> With Corex____, <input checked="" type="checkbox"/> Non
(I)	Type-C Cable	1	<input checked="" type="checkbox"/> Shielded, <input type="checkbox"/> Non	1 m	<input type="checkbox"/> With Corex____, <input checked="" type="checkbox"/> Non
(J)	Dis Play Cable	1	<input checked="" type="checkbox"/> Shielded, <input type="checkbox"/> Non	1.8 m	<input type="checkbox"/> With Corex____, <input checked="" type="checkbox"/> Non
(K)	Dis Play Cable	1	<input checked="" type="checkbox"/> Shielded, <input type="checkbox"/> Non	1.8 m	<input type="checkbox"/> With Corex____, <input checked="" type="checkbox"/> Non
(L)	VGA Cable	1	<input checked="" type="checkbox"/> Shielded, <input type="checkbox"/> Non	1.8 m	<input type="checkbox"/> With Corex____, <input checked="" type="checkbox"/> Non

#### Note:

- 1) All the equipment/cables were placed in the worst-case configuration to maximize the emission during the test.
- 2) Grounding was established in accordance with the manufacturer's requirements and conditions for the intended use.

Report No.: T190308L01-F

## 4.2. CONFIGURATION OF SYSTEM UNDER TEST

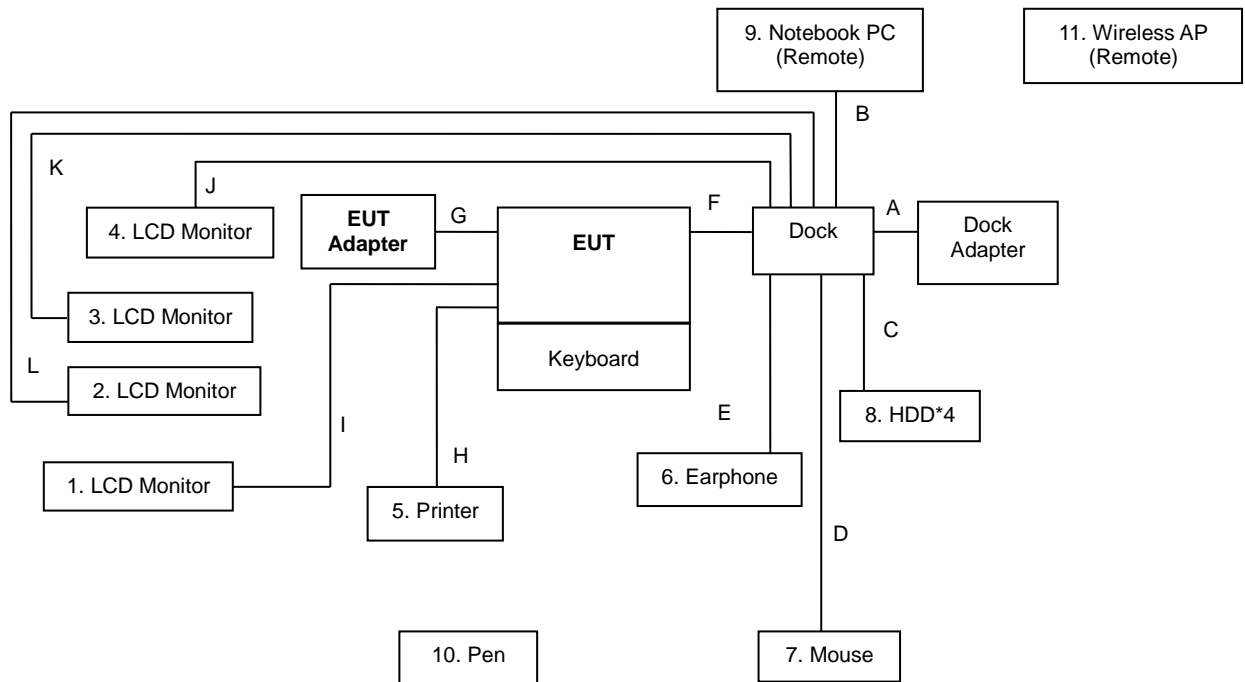



Report No.: T190308L01-F

## 5 FACILITIES AND ACCREDITATIONS

### 5.1. FACILITIES

All measurement facilities used to collect the measurement data are located at:

- No.11, Wugong 6th Rd., Wugu Dist., New Taipei City 24891, Taiwan (R.O.C.)
- No.139, Wugong Rd., Wugu Dist., New Taipei City 24886, Taiwan (R.O.C.)
- No.163-1, Jhongsheng Rd., Sindian City, Taipei County 23151, Taiwan.

The sites are constructed in conformance with the requirements of ANSI C63.4 and CISPR 22. All receiving equipment conforms to CISPR 16-1-1, CISPR 16-1-2, CISPR 16-1-3, CISPR 16-1-4, CISPR 16-1-5.

### 5.2. ACCREDITATIONS

Our laboratories are accredited and approved by the following approval agencies according to ISO/IEC 17025.

<b>Taiwan</b>	TAF (TAF 1309)
<b>USA</b>	A2LA (0824.01)

The measuring facility of laboratories has been authorized or registered by the following approval agencies.

<b>Canada</b>	Industry Canada (10M Semi Anechoic Chamber: IC 2324G-1 / IC 2324G-2 / 2324J-1 / 2324J-2 to perform)
<b>Japan</b>	VCCI Radiated emissions: 30 MHz -1000 MHz: R-14343 / Above 1GHz: G-10945 Conducted Emission B: C-13700 / T-11839
<b>USA</b>	FCC (10M Semi Anechoic Chamber (FCC MRA: TW1039) to perform FCC Part 15 measurements)

Copies of granted accreditation certificates are available for downloading from our web site.

Report No.: T190308L01-F

### 5.3. MEASUREMENT UNCERTAINTY

Where relevant, the following measurement uncertainty levels have been estimated for tests performed on the EUT as specified in CISPR 16-4-2:

Measurement	Frequency	Uncertainty
Conducted emissions #B	0.15MHz ~ 30MHz	±3.14 dB
Radiated emissions (10M Chamber)	30MHz ~ 200MHz	±4.23 dB
	200MHz ~ 1000MHz	±4.13 dB
	1GHz ~ 6GHz	±4.89 dB
	6GHz ~ 18GHz	±5.23 dB
	18GHz ~ 26GHz	±4.13 dB
	26GHz ~ 40GHz	±4.28 dB

This uncertainty represents an expanded uncertainty expressed at approximately the 95% confidence level using a coverage factor of k=2.

Consistent with industry standard (e.g. CISPR 22:2008, clause 11, Measurement Uncertainty) determining compliance with the limits shall be base on the results of the compliance measurement. Consequently the measure emissions being less than the maximum allowed emission result in this be a compliant test or passing test.

The listed uncertainties of above table are the worst case values for the entire range of measurement. Please note that the uncertainty values are only provided for informational purpose and aren't used in determining the PASS/FAIL results.

Report No.: T190308L01-F

## 6 CONDUCTED EMISSION MEASUREMENT

### 6.1. LIMITS OF CONDUCTED EMISSION MEASUREMENT

FREQUENCY (MHz)	Class A (dBuV)		Class B (dBuV)	
	Quasi-peak	Average	Quasi-peak	Average
0.15 - 0.5	79	66	66 - 56	56 - 46
0.50 - 5.0	73	60	56	46
5.0 - 30.0	73	60	60	50

**NOTE:**

- (1) The lower limit shall apply at the transition frequencies.
- (2) The limit decreases in line with the logarithm of the frequency in the range 0.15 to 0.50 MHz
- (3) All emanations from a class A/B digital device or system, including any network of conductors and apparatus connected thereto, shall not exceed the level of field strengths specified above.

### 6.2. TEST INSTRUMENTS

Conducted Emission Room #B					
Name of Equipment	Manufacturer	Model	Serial Number	Calibration Date	Calibration Due
EMI Test Receiver	R&S	ESCI	101073	07/17/2018	07/16/2019
LISN	R&S	ENV216	101054	05/02/2018	05/01/2019
LISN	Schwarzbeck	NSLK8128	5012	04/23/2018	04/22/2019
Software	CCS-3A1-CE				

**Note:** The calibration interval of the above test instruments is 12 months and the calibrations are traceable to NML/ROC and NIST/USA.

Report No.: T190308L01-F

### 6.3. TEST PROCEDURES (please refer to measurement standard or CCS SOP PA-031)

#### Procedure of Preliminary Test

- The EUT and support equipment, if needed, were set up as per the test configuration to simulate typical usage per the user's manual. When the EUT is a tabletop system, a wooden table with a height of 0.8 meters is used and is placed on the ground plane as per ANSI C63.4 (see Test Facility for the dimensions of the ground plane used). When the EUT is a floor standing equipment, it is placed on the ground plane, which has a 12 mm non-conductive covering to insulate the EUT from the ground plane.
- All I/O cables were positioned to simulate typical actual usage as per ANSI C63.4.
- The test equipment EUT installed by AC 120VAC/60Hz main power, through a Line Impedance Stabilization Network (LISN), which was supplied power source and was grounded to the ground plane.
- All support equipment power by from a second LISN.
- The test program of the EUT was started. Emissions were measured on each current carrying line of the EUT using an EMI Test Receiver connected to the LISN powering the EUT.
- The Receiver scanned from 150 kHz to 30MHz for emissions in each of the test modes.
- During the above scans, the emissions were maximized by cable manipulation.
- The test mode(s) described in Item 3.1 were scanned during the preliminary test.
- After the preliminary scan, we found the test mode described in Item 3.1 producing the highest emission level.
- The worst configuration of EUT and cable of the above highest emission level were recorded for reference of the final test.

#### Procedure of Final Test

- EUT and support equipment were set up on the test bench as per the configuration with highest emission level in the preliminary test.
- A scan was taken on both power lines, Line 1 and Line 2, recording at least the six highest emissions. Emission frequency and amplitude were recorded into a computer in which correction factors were used to calculate the emission level and compare reading to the applicable limit.
- The test data of the worst-case condition(s) was recorded.



Report No.: T190308L01-F

### 6.4. TEST SETUP

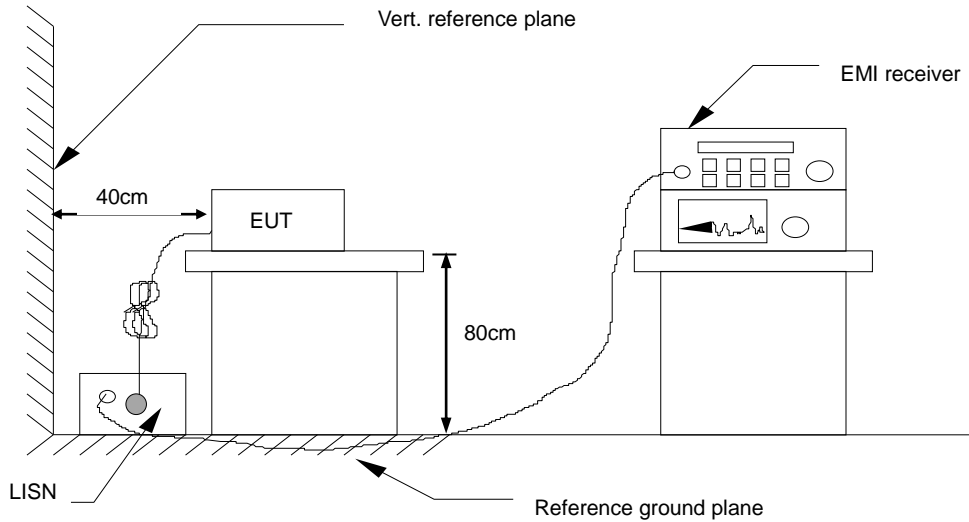

- For the actual test configuration, please refer to the related item – Photographs of the Test Configuration.

### 6.5. DATA SAMPLE:

Frequency (MHz)	QuasiPeak reading (dBuV)	Average reading (dBuV)	Correctrion factor (dB)	QuasiPeak result (dBuV)	Average result (dBuV)	QuasiPeak. limit (dBuV)	Average limit (dBuV)	QuasiPeak margin (dB)	Average margin (dB)	Remark
x.xx	43.95	33.00	10.00	53.95	43.00	56.00	46.00	-2.05	-3.00	Pass

Frequency (MHz) = Emission frequency in MHz  
 Reading (dBuV) = Uncorrected Analyzer/Receiver reading + Insertion loss of LISN, if it > 0.5 dB  
 Correction Factor (dB) = LISN Factor + Cable Loss  
 Result (dBuV) = Raw reading converted to dBuV and CF added  
 Limit (dBuV) = Limit stated in standard  
 Margin (dB) = Result (dBuV) – Limit (dBuV)

### 6.6. TEST RESULTS

<b>Model no.</b>	HSN-C04C	<b>Line:</b>	L1
<b>Environmental Conditions</b>	24°C, 50% RH	<b>Test Date</b>	2019/4/10
<b>Test Mode</b>	Mode 16	<b>Tested by</b>	Wiz Chang
<b>6dB Bandwidth</b>	9 kHz	<b>Identifier number</b>	TCOP CE site 17

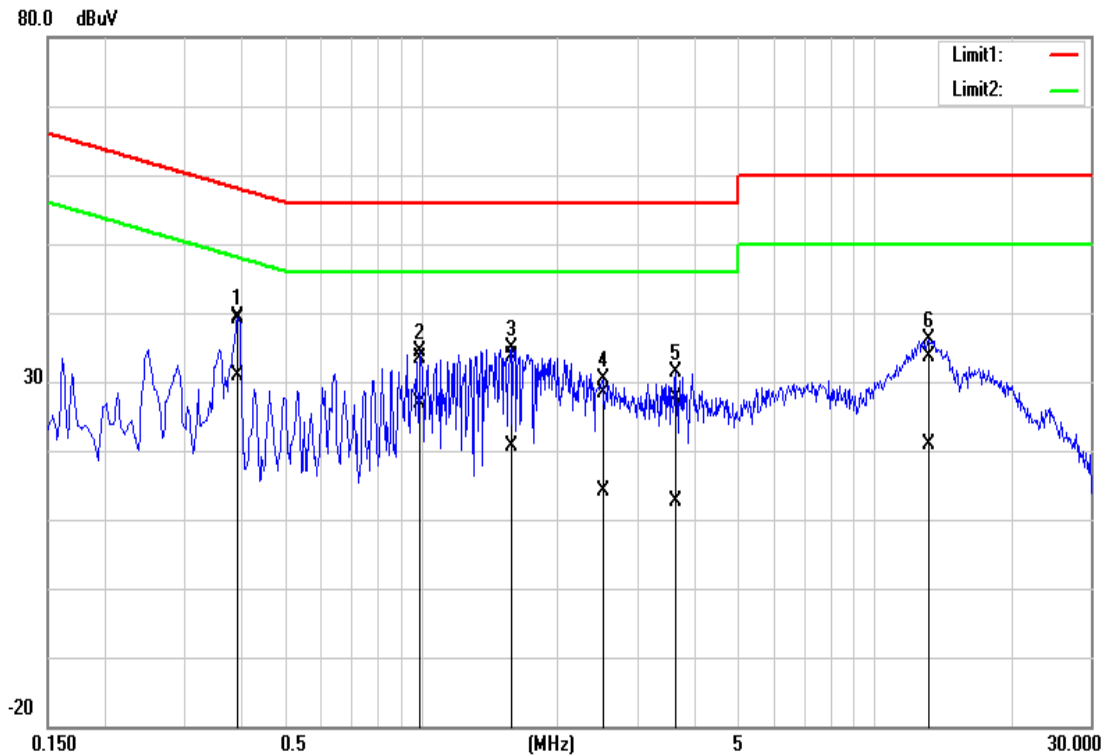

NO.	Frequency (MHz)	Quasi Peak reading (dBuV)	Average reading (dBuV)	Correction factor (dB)	Quasi Peak result (dBuV)	Average result (dBuV)	Quasi Peak limit (dBuV)	Average limit (dBuV)	Quasi Peak margin (dB)	Average margin (dB)	Remark (Pass/Fail)
1*	0.3940	29.49	21.05	9.76	39.25	30.81	57.98	47.98	-18.73	-17.17	Pass
2	0.9980	23.63	17.00	9.78	33.41	26.78	56.00	46.00	-22.59	-19.22	Pass
3	1.5780	23.75	10.90	9.80	33.55	20.70	56.00	46.00	-22.45	-25.30	Pass
4	2.5140	18.56	4.28	9.80	28.36	14.08	56.00	46.00	-27.64	-31.92	Pass
5	3.6540	17.72	2.74	9.82	27.54	12.56	56.00	46.00	-28.46	-33.44	Pass
6	13.1700	23.62	10.83	10.00	33.62	20.83	60.00	50.00	-26.38	-29.17	Pass

**Note:** L1 = Line One (Live Line)

Report No.: T190308L01-F

<b>Model no.</b>	HSN-C04C	<b>Line:</b>	L2
<b>Environmental Conditions</b>	24°C, 50% RH	<b>Test Date</b>	2019/4/10
<b>Test Mode</b>	Mode 16	<b>Tested by</b>	Wiz Chang
<b>6dB Bandwidth</b>	9 kHz	<b>Identifier number</b>	TCOP CE site 17

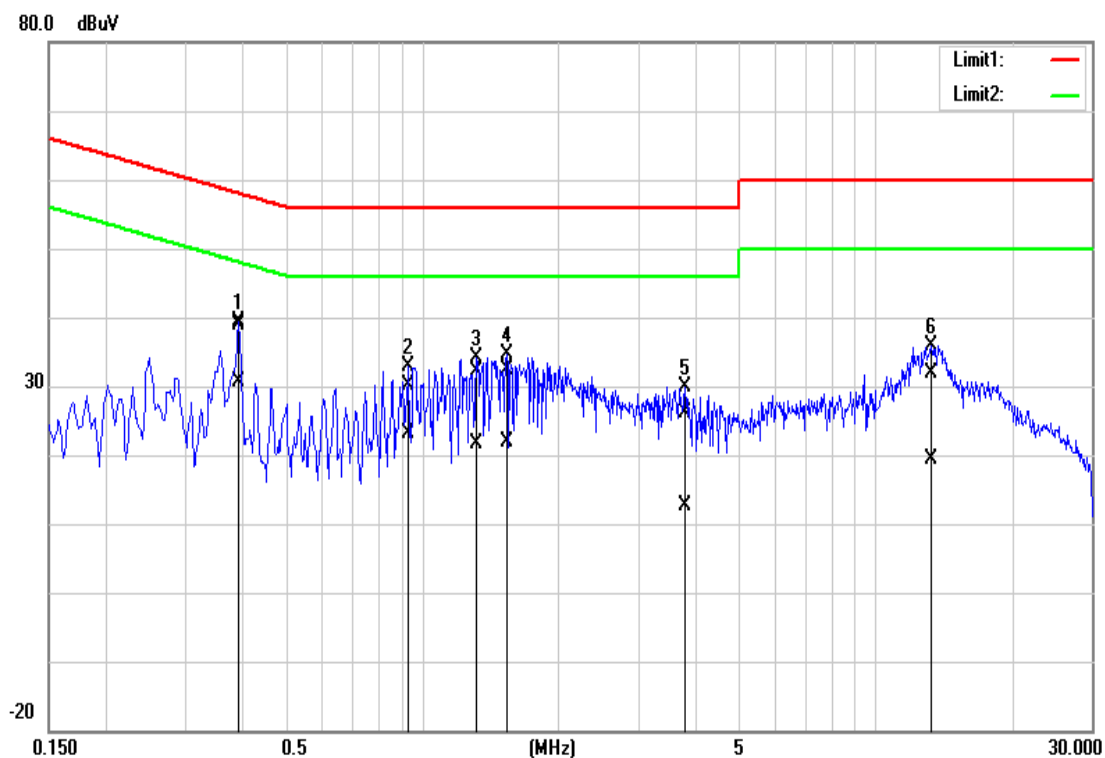

NO.	Frequency (MHz)	Quasi Peak reading (dBuV)	Average reading (dBuV)	Correction factor (dB)	Quasi Peak result (dBuV)	Average result (dBuV)	Quasi Peak limit (dBuV)	Average limit (dBuV)	Quasi Peak margin (dB)	Average margin (dB)	Remark (Pass/Fail)
1*	0.3940	29.18	20.82	9.74	38.92	30.56	57.98	47.98	-19.06	-17.42	Pass
2	0.9340	20.34	13.42	9.75	30.09	23.17	56.00	46.00	-25.91	-22.83	Pass
3	1.3220	22.35	11.85	9.75	32.10	21.60	56.00	46.00	-23.90	-24.40	Pass
4	1.5380	22.67	12.07	9.77	32.44	21.84	56.00	46.00	-23.56	-24.16	Pass
5	3.8180	16.44	2.91	9.80	26.24	12.71	56.00	46.00	-29.76	-33.29	Pass
6	13.3140	21.79	9.50	10.00	31.79	19.50	60.00	50.00	-28.21	-30.50	Pass

**Note:** L2 = Line Two (Neutral Line).

Report No.: T190308L01-F

<b>Model no.</b>	HSN-C04C	<b>Line:</b>	L1
<b>Environmental Conditions</b>	24°C, 50% RH	<b>Test Date</b>	2019/4/16
<b>Test Mode</b>	Mode 17	<b>Tested by</b>	Wiz Chang
<b>6dB Bandwidth</b>	9 kHz	<b>Identifier number</b>	TCOP CE site 17

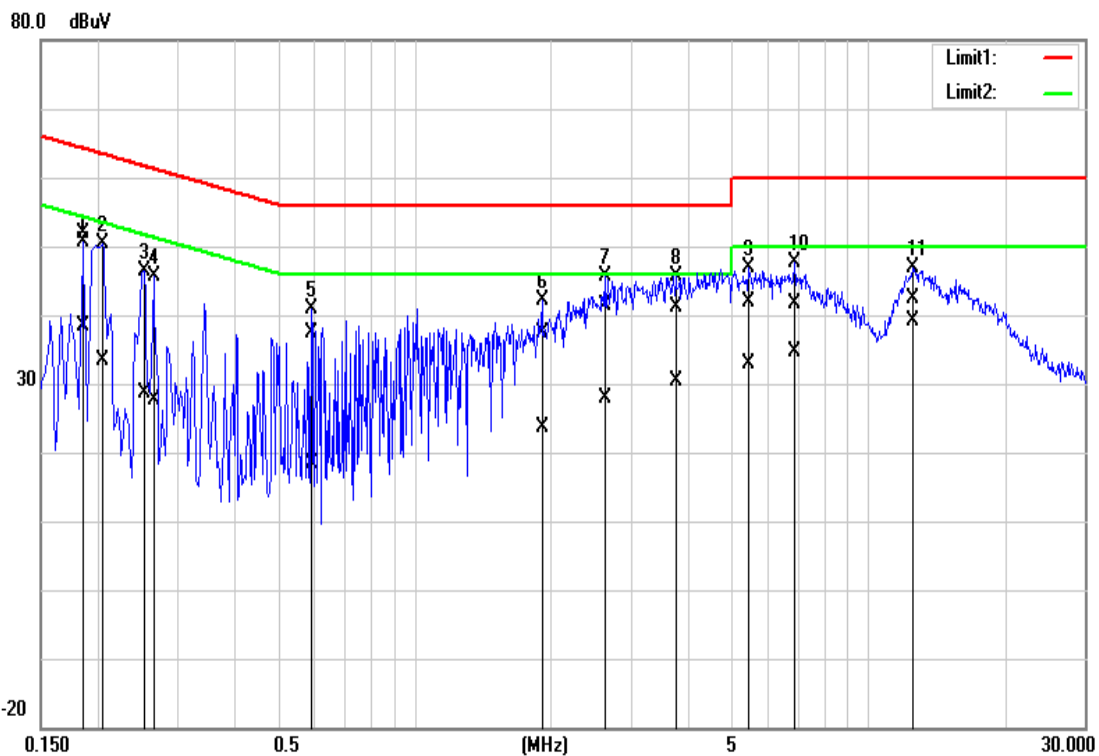

NO.	Frequency (MHz)	Quasi Peak reading (dBuV)	Average reading (dBuV)	Correction factor (dB)	Quasi Peak result (dBuV)	Average result (dBuV)	Quasi Peak limit (dBuV)	Average limit (dBuV)	Quasi Peak margin (dB)	Average margin (dB)	Remark (Pass/Fail)
1	0.1860	42.18	28.52	9.76	51.94	38.28	64.21	54.21	-12.27	-15.93	Pass
2	0.2060	40.60	23.51	9.76	50.36	33.27	63.36	53.37	-13.00	-20.10	Pass
3	0.2540	36.63	18.79	9.76	46.39	28.55	61.62	51.63	-15.23	-23.08	Pass
4	0.2660	35.90	17.91	9.76	45.66	27.67	61.24	51.24	-15.58	-23.57	Pass
5	0.5940	27.67	8.71	9.76	37.43	18.47	56.00	46.00	-18.57	-27.53	Pass
6	1.9100	27.61	13.80	9.80	37.41	23.60	56.00	46.00	-18.59	-22.40	Pass
7	2.6300	31.48	18.09	9.80	41.28	27.89	56.00	46.00	-14.72	-18.11	Pass
8	3.7660	31.32	20.67	9.82	41.14	30.49	56.00	46.00	-14.86	-15.51	Pass
9	5.4740	31.96	23.03	9.85	41.81	32.88	60.00	50.00	-18.19	-17.12	Pass
10	6.8860	31.82	24.66	9.88	41.70	34.54	60.00	50.00	-18.30	-15.46	Pass
11*	12.5700	32.43	29.02	10.00	42.43	39.02	60.00	50.00	-17.57	-10.98	Pass

**Note:** L1 = Line One (Live Line)

Report No.: T190308L01-F

<b>Model no.</b>	HSN-C04C	<b>Line:</b>	L2
<b>Environmental Conditions</b>	24°C, 50% RH	<b>Test Date</b>	2019/4/16
<b>Test Mode</b>	Mode 17	<b>Tested by</b>	Wiz Chang
<b>6dB Bandwidth</b>	9 kHz	<b>Identifier number</b>	TCOP CE site 17

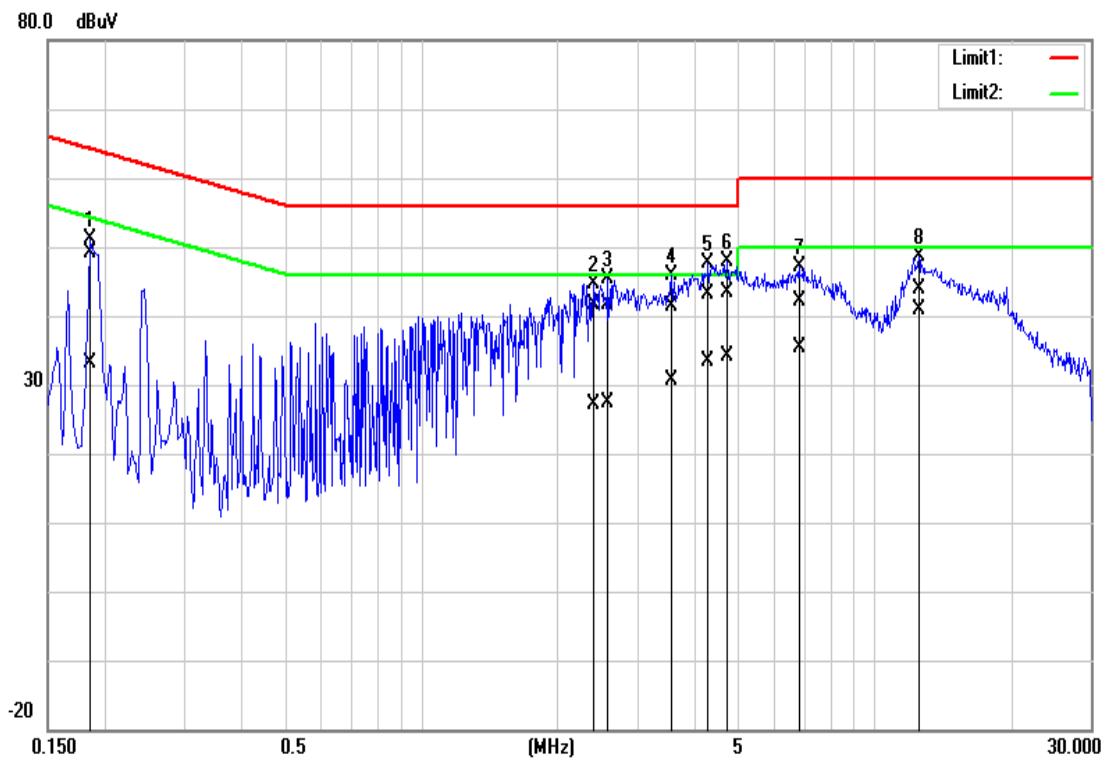

NO.	Frequency (MHz)	Quasi Peak reading (dBuV)	Average reading (dBuV)	Correction factor (dB)	Quasi Peak result (dBuV)	Average result (dBuV)	Quasi Peak limit (dBuV)	Average limit (dBuV)	Quasi Peak margin (dB)	Average margin (dB)	Remark (Pass/Fail)
1	0.1860	39.28	23.34	9.73	49.01	33.07	64.21	54.21	-15.20	-21.14	Pass
2	2.4020	31.86	17.45	9.77	41.63	27.22	56.00	46.00	-14.37	-18.78	Pass
3	2.5860	31.97	17.68	9.78	41.75	27.46	56.00	46.00	-14.25	-18.54	Pass
4	3.5740	31.70	20.79	9.80	41.50	30.59	56.00	46.00	-14.50	-15.41	Pass
5	4.2980	33.35	23.55	9.80	43.15	33.35	56.00	46.00	-12.85	-12.65	Pass
6	4.7340	33.44	24.24	9.82	43.26	34.06	56.00	46.00	-12.74	-11.94	Pass
7	6.8300	32.27	25.44	9.87	42.14	35.31	60.00	50.00	-17.86	-14.69	Pass
8*	12.5580	33.85	30.77	10.00	43.85	40.77	60.00	50.00	-16.15	-9.23	Pass

**Note:** L2 = Line Two (Neutral Line).

Report No.: T190308L01-F

## 7 RADIATED EMISSION MEASUREMENT

### 7.1. LIMITS OF RADIATED EMISSION MEASUREMENT

According to FCC Part 15.33 (b), for an unintentional radiator, including a digital device, the spectrum shall be investigated from the lowest radio frequency signal generated or used in the device, without going below the lowest frequency for which a radiated emission limit is specified, up to the frequency shown in the following table:

Highest frequency generated or used in the device or on which the device operates or tunes (MHz)	Upper frequency of measurement range (MHz)
Below 1.75	30
1.75-108	1000
108-500	2000
500-1000	5000
Above 1000	5 <sup>th</sup> harmonic of the highest frequency or 40GHz, whichever is lower

#### Below 1GHz (for digital device)

FREQUENCY (MHz)	dBuV/m (At 10m)	
	Class A	Class B
30 ~ 230	40	30
230 ~ 1000	47	37

#### Limit tables for digital device:

##### Class A Radiated Emission limit at 10m (for others)

Frequency (MHz)	Field Strength Limit (uV/m)Q.P.	Field Strength Limit (dBuV/m)Q.P.
30 - 88	90	39
88 - 216	150	43.5
216 - 960	210	46.4
Above 960	300	49.5

##### Class B Radiated Emission limit at 3m (for others)

Frequency (MHz)	Field Strength Limit (uV/m)Q.P.	Field Strength Limit (dBuV/m)Q.P.
30 - 88	100	40
88 - 216	150	43.5
216 - 960	200	46
Above 960	500	54

Report No.: T190308L01-F

**Above 1GHz (for all device)**

Frequency (MHz)	Class A (dBuV/m) (At 10m)		Class B (dBuV/m) (At 3m)	
	Average	Peak	Average	Peak
Above 1000	49.5	69.5	54	74

- NOTE:** (1) The lower limit shall apply at the transition frequencies.  
 (2) Emission level (dBuV/m) = 20 log Emission level (uV/m).  
 (3) The measurement above 1GHz is at close-in distances 3m, and determine the limit **L2** corresponding to the close-in distance **d2** by applying the following relation:  $L2 = L1 (d1/d2)$ , where **L1** is the specified limit in microvolts per metre (**uV/m**) at the distance **d1 (10m)**, **L2** is the new limit for distance **d2 (3m)**.

So the new Class A limit above 1GHz at 3m is as following table:

Frequency (MHz)	Class A (dBuV/m) (At 3m)	
	Average	Peak
Above 1000	60	80

Report No.: T190308L01-F

## 7.2. TEST INSTRUMENTS

### Below 1GHz

Wugu 10M Chamber					
Name of Equipment	Manufacturer	Model	Serial Number	Calibration Date	Calibration Due
Bilog Antenna	TESEQ	CBL 6112D	31674	03/06/2019	03/05/2020
Bilog Antenna	TESEQ	CBL 6112D	31675	03/22/2019	03/21/2020
Coaxial Cable	Huber+Suhner	SUCOFLEX 104PEA	330029	05/02/2018	05/01/2019
Coaxial Cable	Huber+Suhner	SUCOFLEX 104PEA	33948/4PEA	05/02/2018	05/01/2019
Coaxial Cable	Huber+Suhner	SUCOFLEX 104PEA	33949/4PEA	05/02/2018	05/01/2019
Coaxial Cable	Huber+Suhner	SUCOFLEX 104PEA	24813	05/02/2018	05/01/2019
EMI Test Receiver	R&S	ESCI	100961	07/04/2018	07/03/2019
EMI Test Receiver	R&S	ESCI	100962	07/10/2018	07/09/2019
Pre-Amplifier	HP	8447D	2944A07754	05/02/2018	05/01/2019
Pre-Amplifier	HP	8447D	2944A08150	05/02/2018	05/01/2019
AC POWER SOURE	APE	AFC-130	991259	N.C.R	N.C.R
Antenna Tower	CCS	CC-A-1F	N/A	N.C.R	N.C.R
Antenna Tower	Sunol Sciences	TLT2	031010-5	N.C.R	N.C.R
Controller	CCS	CC-C-1F	N/A	N.C.R	N.C.R
Controller	Sunol Sciences	SC104V	031010-1	N.C.R	N.C.R
Turn Table	CCS	CC-T-1F	N/A	N.C.R	N.C.R
Software	EZ-EMC (CCS-3A1RE)				

**Note:**

1. The calibration interval of the above test instruments is 12 months and the calibrations are traceable to NML/ROC and NIST/USA.
2. N.C.R. = No Calibration Required.



Report No.: T190308L01-F

**Above 1GHz**

Wugu 10M Chamber					
Name of Equipment	Manufacturer	Model	Serial Number	Calibration Date	Calibration Due
Coaxial Cable	Huber+Suhner	SUCOFLEX 104PEA	329383	05/02/2018	05/01/2019
Coaxial Cable	Huber+Suhner	SUCOFLEX 104PEA	33945	05/02/2018	05/01/2019
Horn Antenna	ETS LINDGREN	3116	00026370	12/26/2018	12/25/2019
Horn Antenna	EMCO	3117	00055167	12/24/2018	12/23/2019
Pre-Amplifier	EMCI	EMC051845	980040	05/02/2018	05/01/2019
Pre-Amplifier	MITEQ	AMF-6F-260400 -40-8P	985646	06/21/2018	06/20/2019
Spectrum Analyzer	Agilent	E4446A	MY48250297	08/30/2018	08/29/2019
AC POWER SOURCE	APE	AFC-130	991259	N.C.R	N.C.R
Antenna Tower	Sunol Sciences	TLT2	031010-5	N.C.R	N.C.R
Controller	Sunol Sciences	SC104V	031010-1	N.C.R	N.C.R
Turn Table	CCS	CC-T-1F	N/A	N.C.R	N.C.R
Software	EZ-EMC (CCS-3A1RE)				

**Note:**

1. The calibration interval of the above test instruments is 12 months and the calibrations are traceable to NML/ROC and NIST/USA.
2. N.C.R. = No Calibration Required.

Report No.: T190308L01-F

### 7.3. TEST PROCEDURES (please refer to measurement standard or CCS SOP PA-031)

The basic test procedure was in accordance with ANSI C63.4-2014 and ICES-003-2016.

#### Frequency range 30MHz ~ 1GHz

1. The EUT was placed on the top of a rotating table 0.8 meters above the ground at a 10 meter semi-anechoic chamber room. The table was rotated 360 degrees to determine the position.
2. The EUT was set 10 meters away from the interference-receiving antenna, which was mounted on the top of a variable-height antenna tower.
3. The height of antenna is varied form one meter to four meter above the ground to determine the maximum value of the field strength. Both horizontal and vertical polarizations of the antenna are set to make the measurement.
4. For each suspected emission, the EUT was arranged to its worst case and then the antenna was turned to heights for 1 meter to 4 meters and the turn table was turned from 0 degrees to 360 degrees to find the maximum reading.
5. The test-receiver system was set to quasi-peak detect function and specified bandwidth with maximum hold mode when the test frequency is below 1GHz.

NOTE: The resolution bandwidth of test receiver/spectrum analyzer is 120 kHz for Quasi-peak detection (QP) at frequency below 1GHz.

**Report No.:** T190308L01-F

### **Frequency range above 1GHz**

1. The EUT was placed on the top of a rotating table 0.8 meters above the ground at a 3 meter semi-anechoic chamber room. The table was rotated 360 degrees to determine the position.
2. The EUT was set 3 meters away from the directional antenna, which was pointed towards the source of the emission within the EUT. This could be done by either pointing the antenna at an angle towards the source of the emission, or by rotating the EUT, in both height and polarization, to maximize the measured emission.
3. The height of antenna can be varied from one meter to four meters, the height of adjustment depends on the EUT height and the antenna 3 dB beam width both, to detect the maximum value of the field strength. Both horizontal and vertical polarizations of the antenna are set to make the measurement.
4. For each suspected emission, the EUT was arranged to its worst case and then the antenna was turned to heights and the rotatable table was turned from 0 degrees to 360 degrees to find the maximum reading.
5. The test-receiver system was set to peak and average detect function and specified bandwidth with maximum hold mode when the test frequency is above 1GHz.

#### **NOTE:**

1. The resolution bandwidth is 1MHz and video bandwidth of test spectrum analyzer is 1 MHz for peak detection at above 1GHz. The resolution bandwidth is 1MHz and video bandwidth of test spectrum analyzer is 100Hz for average detection at frequency above 1 GHz.
2. For measurement of frequency above 1GHz, the EUT was set 3 meters away from the directional antenna.

Report No.: T190308L01-F

## 7.4. TEST SETUP

### Below 1GHz

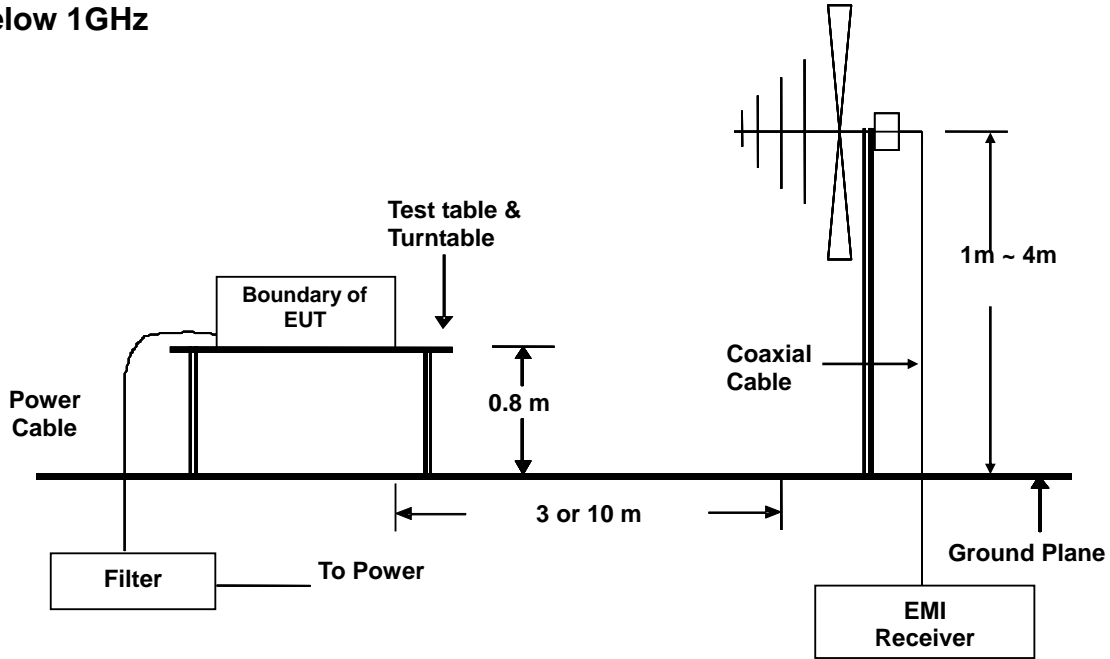

### Above 1GHz

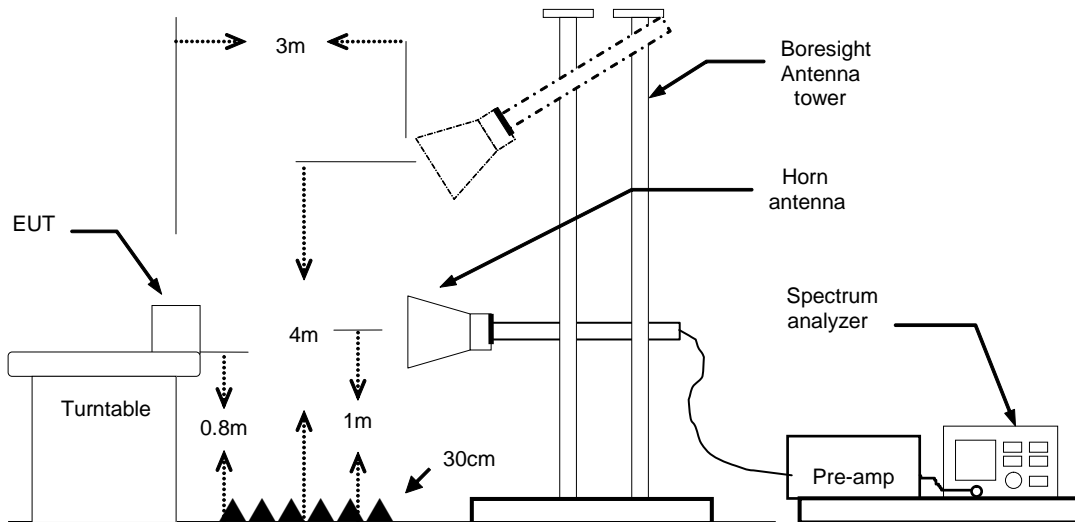

- For the actual test configuration, please refer to the related item – Photographs of the Test Configuration.

Report No.: T190308L01-F

## 7.5. DATA SAMPLE:

### Below 1GHz

Frequency (MHz)	Reading (dBuV)	Correction Factor (dB/m)	Result (dBuV/m)	Limit (dBuV/m)	Margin (dB)	Height (cm)	Degree (°)	Remark
xx.xx	16.49	9.86	26.35	30.00	-3.65	116.00	101.00	QP

### Above 1GHz

Frequency (MHz)	Reading (dBuV)	Correction Factor (dB/m)	Result (dBuV/m)	Limit (dBuV/m)	Margin (dB)	Height (cm)	Degree (°)	Remark
xx.xx	60.80	-14.59	46.21	74.00	-27.79	200	351	peak
xx.xx	52.05	-13.17	38.88	54.00	-15.12	200	135	AVG

Frequency (MHz) = Emission frequency in MHz  
 Reading (dBuV) = Uncorrected Analyzer / Receiver reading  
 Correction Factor (dB/m) = Antenna factor + Cable loss – Amplifier gain  
 Result (dBuV/m) = Reading (dBuV) + Corr. Factor (dB/m)  
 Limit (dBuV/m) = Limit stated in standard  
 Margin (dB) = Result (dBuV/m) – Limit (dBuV/m)  
 Q.P. = Quasi-Peak

Report No.: T190308L01-F

### 7.6. TEST RESULTS

Below 1GHz

Model no.	HSN-C04C	Test Mode	Mode 16
Environmental Conditions	26°C, 60% RH	Test Date	2019/3/31
Antenna Pole	Vertical	Antenna Distance	10m
Detector Function	Quasi-peak.	Tested by	Rex Kuo
6dB Bandwidth	120 kHz	Identifier number	TCOP RE site 17

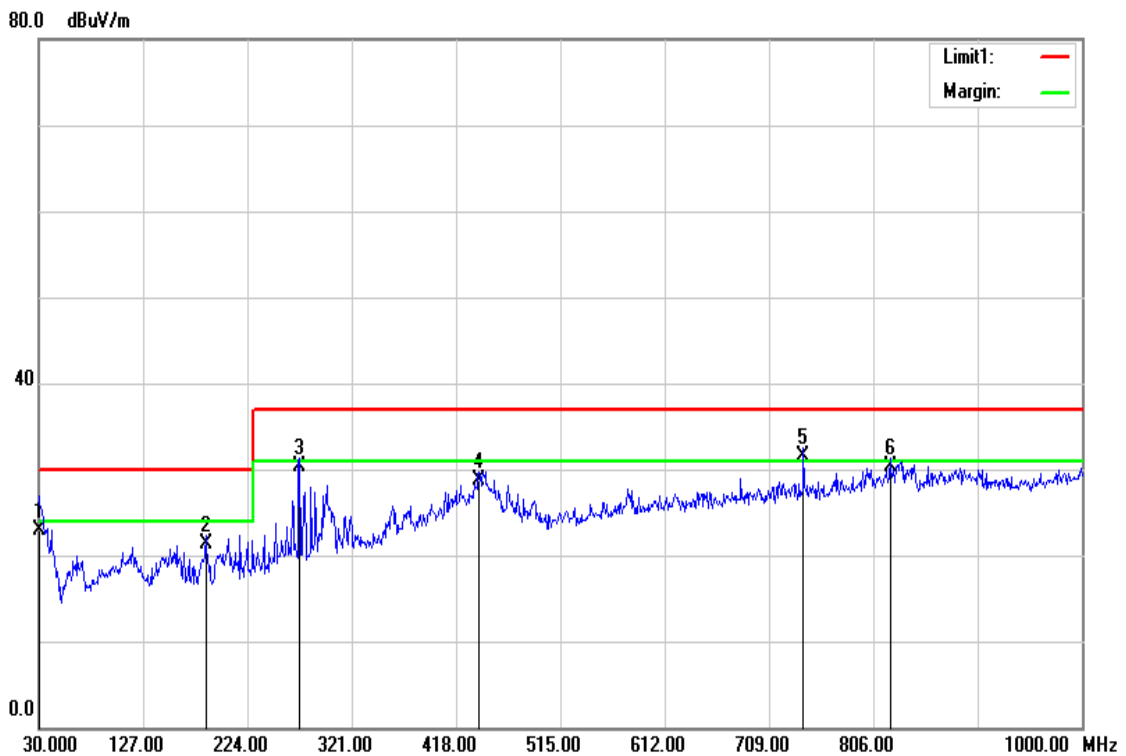

No.	Frequency (MHz)	Reading (dBuV)	Correction Factor (dB/m)	Result (dBuV/m)	Limit (dBuV/m)	Margin (dB)	Height (cm)	Degree (°)	Remark
1	30.0000	25.17	-2.30	22.87	30.00	-7.13	100	68	QP
2	185.2000	30.98	-9.77	21.21	30.00	-8.79	101	360	QP
3	272.5000	34.90	-4.62	30.28	37.00	-6.72	100	1	QP
4	439.3400	29.64	-1.00	28.64	37.00	-8.36	100	344	QP
5	741.0100	28.53	2.93	31.46	37.00	-5.54	200	106	QP
6	821.5200	26.35	3.89	30.24	37.00	-6.76	200	87	QP

**REMARKS:**

1. The other emission levels were very low against the limit.
2. 30MHz to 1000MHz test is Applicable CISPR 22 standard.

Report No.: T190308L01-F

<b>Model no.</b>	HSN-C04C	<b>Test Mode</b>	Mode 16
<b>Environmental Conditions</b>	26°C, 60% RH	<b>Test Date</b>	2019/3/31
<b>Antenna Pole</b>	Horizontal	<b>Antenna Distance</b>	10m
<b>Detector Function</b>	Quasi-peak.	<b>Tested by</b>	Rex Kuo
<b>6dB Bandwidth</b>	120 kHz	<b>Identifier number</b>	TCOP RE site 17

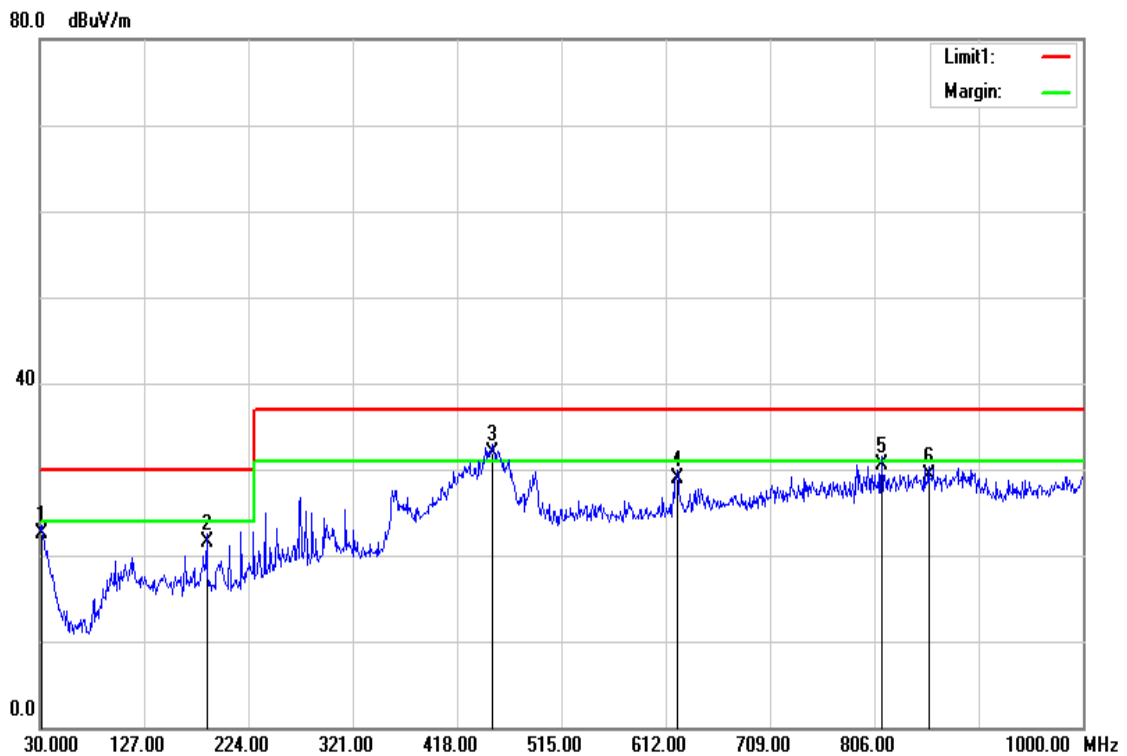

No.	Frequency (MHz)	Reading (dBuV)	Correction Factor (dB/m)	Result (dBuV/m)	Limit (dBuV/m)	Margin (dB)	Height (cm)	Degree (°)	Remark
1	31.9400	26.51	-4.06	22.45	30.00	-7.55	399	23	QP
2	185.2000	32.44	-10.92	21.52	30.00	-8.48	399	170	QP
3	450.9800	34.65	-2.75	31.90	37.00	-5.10	200	29	QP
4	622.6700	29.29	-0.42	28.87	37.00	-8.13	100	359	QP
5	812.7900	28.84	1.60	30.44	37.00	-6.56	100	247	QP
6	856.4400	27.05	2.29	29.34	37.00	-7.66	100	247	QP

**REMARKS:**

1. The other emission levels were very low against the limit.
2. 30MHz to 1000MHz test is Applicable CISPR 22 standard.

Report No.: T190308L01-F

<b>Model no.</b>	HSN-C04C	<b>Test Mode</b>	Mode 17
<b>Environmental Conditions</b>	26°C, 60% RH	<b>Test Date</b>	2019/4/17
<b>Antenna Pole</b>	Vertical	<b>Antenna Distance</b>	10m
<b>Detector Function</b>	Quasi-peak.	<b>Tested by</b>	Rex Kuo
<b>6dB Bandwidth</b>	120 kHz	<b>Identifier number</b>	TCOP RE site 17

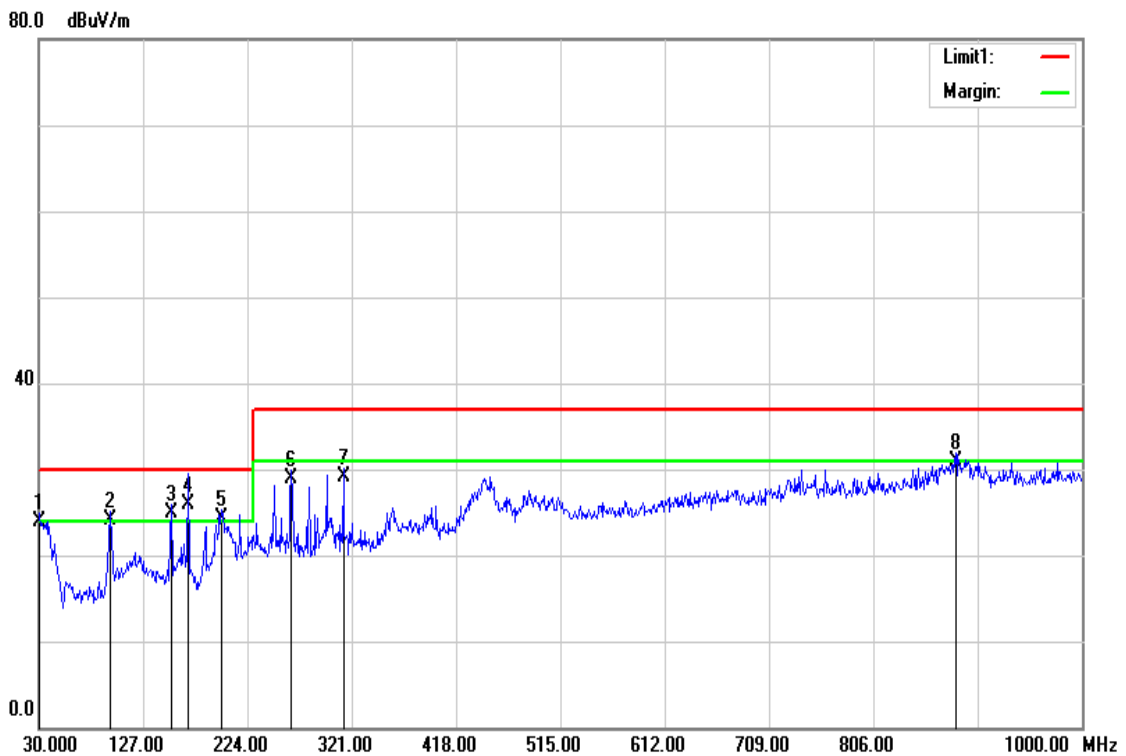

No.	Frequency (MHz)	Reading (dBuV)	Correction Factor (dB/m)	Result (dBuV/m)	Limit (dBuV/m)	Margin (dB)	Height (cm)	Degree (°)	Remark
1	30.0000	26.23	-2.30	23.93	30.00	-6.07	200	130	QP
2	95.9600	34.06	-9.98	24.08	30.00	-5.92	108	360	QP
3	153.1900	33.72	-8.82	24.90	30.00	-5.10	100	357	QP
4	168.8220	35.37	-9.41	25.96	30.00	-4.04	100	175	QP
5	199.7500	33.45	-9.18	24.27	30.00	-5.73	100	360	QP
6	264.7400	33.18	-4.35	28.83	37.00	-8.17	100	354	QP
7	313.2400	33.25	-4.13	29.12	37.00	-7.88	100	360	QP
8	882.6300	25.97	5.02	30.99	37.00	-6.01	200	112	QP

**REMARKS:**

1. The other emission levels were very low against the limit.
2. 30MHz to 1000MHz test is Applicable CISPR 22 standard.



Report No.: T190308L01-F

<b>Model no.</b>	HSN-C04C	<b>Test Mode</b>	Mode 17
<b>Environmental Conditions</b>	26°C, 60% RH	<b>Test Date</b>	2019/4/17
<b>Antenna Pole</b>	Horizontal	<b>Antenna Distance</b>	10m
<b>Detector Function</b>	Quasi-peak.	<b>Tested by</b>	Rex Kuo
<b>6dB Bandwidth</b>	120 kHz	<b>Identifier number</b>	TCOP RE site 17

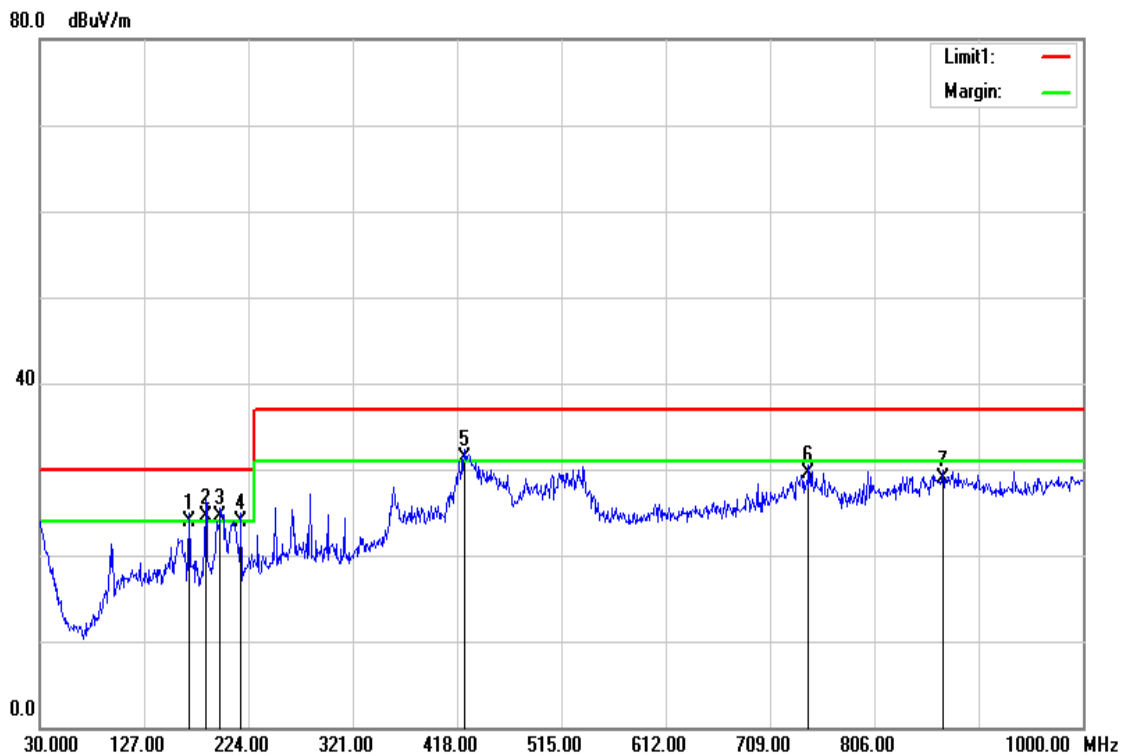

No.	Frequency (MHz)	Reading (dBuV)	Correction Factor (dB/m)	Result (dBuV/m)	Limit (dBuV/m)	Margin (dB)	Height (cm)	Degree (°)	Remark
1	168.7100	34.60	-10.62	23.98	30.00	-6.02	399	59	QP
2	184.9700	35.52	-10.93	24.59	30.00	-5.41	398	14	QP
3	197.8100	35.16	-10.61	24.55	30.00	-5.45	300	198	QP
4	217.2100	34.11	-10.27	23.84	30.00	-6.16	200	202	QP
5	424.7900	34.19	-2.79	31.40	37.00	-5.60	200	358	QP
6	744.8900	28.46	1.04	29.50	37.00	-7.50	100	137	QP
7	870.0200	26.30	2.51	28.81	37.00	-8.19	100	83	QP

**REMARKS:**

1. The other emission levels were very low against the limit.
2. 30MHz to 1000MHz test is Applicable CISPR 22 standard.

Report No.: T190308L01-F

**Above 1GHz**

<b>Model no.</b>	HSN-C04C	<b>Test Mode</b>	Mode 16
<b>Environmental Conditions</b>	26°C, 60% RH	<b>Test Date</b>	2019/3/31
<b>Antenna Pole</b>	Vertical	<b>Antenna Distance</b>	3m
<b>Highest frequency generated or used</b>	1.6GHz	<b>Upper frequency</b>	8GHz
<b>Detector Function</b>	Peak & Average	<b>Tested by</b>	Rex Kuo
<b>6dB Bandwidth</b>	1 MHz	<b>Identifier number</b>	TCOP RF site 17

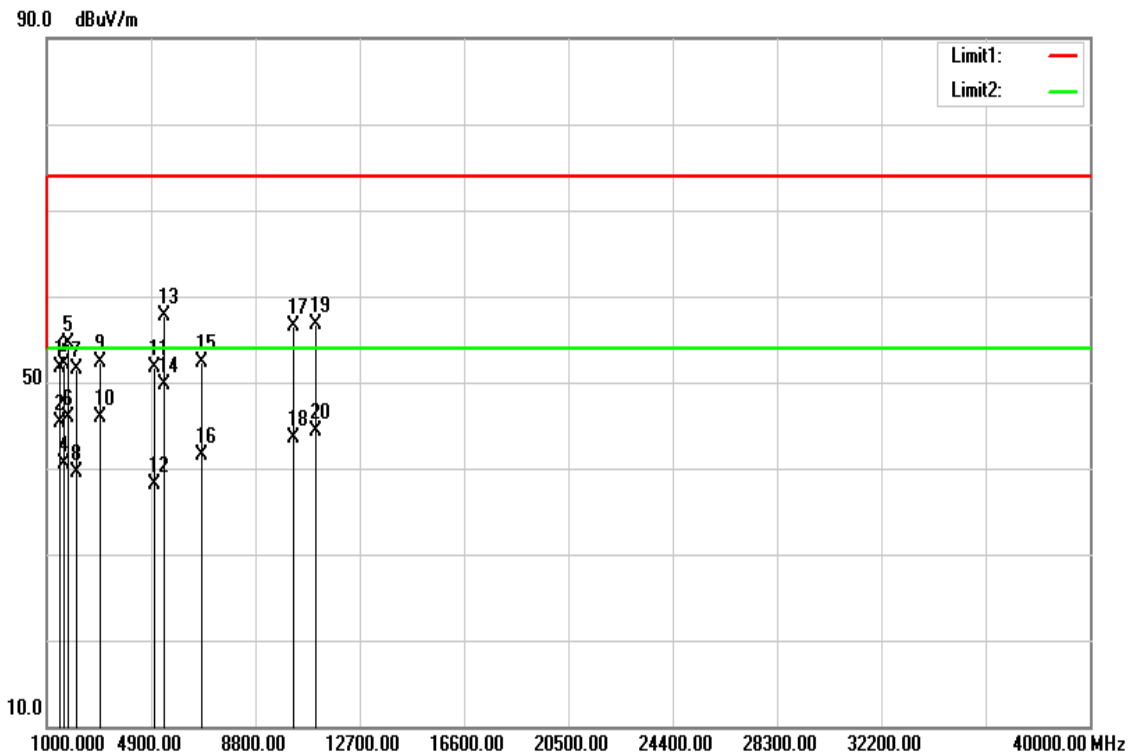

No.	Frequency (MHz)	Reading (dBuV)	Correction Factor (dB/m)	Result (dBuV/m)	Limit (dBuV/m)	Margin (dB)	Height (cm)	Degree (°)	Remark
1	1484.500	70.26	-18.57	51.69	74.00	-22.31	100	119	peak
2	1484.500	63.89	-18.57	45.32	54.00	-8.68	100	119	AVG
3	1603.500	69.73	-17.69	52.04	74.00	-21.96	100	279	peak
4	1603.500	58.28	-17.69	40.59	54.00	-13.41	100	279	AVG
5	1782.000	70.71	-16.21	54.50	74.00	-19.50	100	0	peak
6	1782.000	62.09	-16.21	45.88	54.00	-8.12	100	0	AVG
7	2122.000	65.89	-14.33	51.56	74.00	-22.44	300	70	peak
8	2122.000	53.84	-14.33	39.51	54.00	-14.49	300	70	AVG
9	2963.500	64.92	-12.56	52.36	74.00	-21.64	200	81	peak
10	2963.500	58.48	-12.56	45.92	54.00	-8.08	200	81	AVG



Report No.: T190308L01-F

11	4986.500	60.08	-8.36	51.72	74.00	-22.28	100	68	peak
12	4986.500	46.41	-8.36	38.05	54.00	-15.95	100	68	AVG
13	5403.000	65.14	-7.35	57.79	74.00	-16.21	100	359	peak
14	5403.000	57.14	-7.35	49.79	54.00	-4.21	100	359	AVG
15	6737.500	56.05	-3.77	52.28	74.00	-21.72	168	0	peak
16	6737.500	45.23	-3.77	41.46	54.00	-12.54	168	0	AVG
17	10180.000	55.01	1.56	56.57	74.00	-17.43	246	360	peak
18	10180.000	42.01	1.56	43.57	54.00	-10.43	246	360	AVG
19	11047.000	53.19	3.59	56.78	74.00	-17.22	200	360	peak
20	11047.000	40.68	3.59	44.27	54.00	-9.73	200	360	AVG

**REMARKS:**

1. The other emission levels were very low against the limit.
2. Margin (dB) = Result (dBuV/m) – Limit (dBuV/m)

Report No.: T190308L01-F

<b>Model no.</b>	HSN-C04C	<b>Test Mode</b>	Mode 16
<b>Environmental Conditions</b>	26°C, 60% RH	<b>Test Date</b>	2019/3/31
<b>Antenna Pole</b>	Horizontal	<b>Antenna Distance</b>	3m
<b>Highest frequency generated or used</b>	1.6GHz	<b>Upper frequency</b>	8GHz
<b>Detector Function</b>	Peak & Average	<b>Tested by</b>	Rex Kuo
<b>6dB Bandwidth</b>	1 MHz	<b>Identifier number</b>	TCOP RF site 17

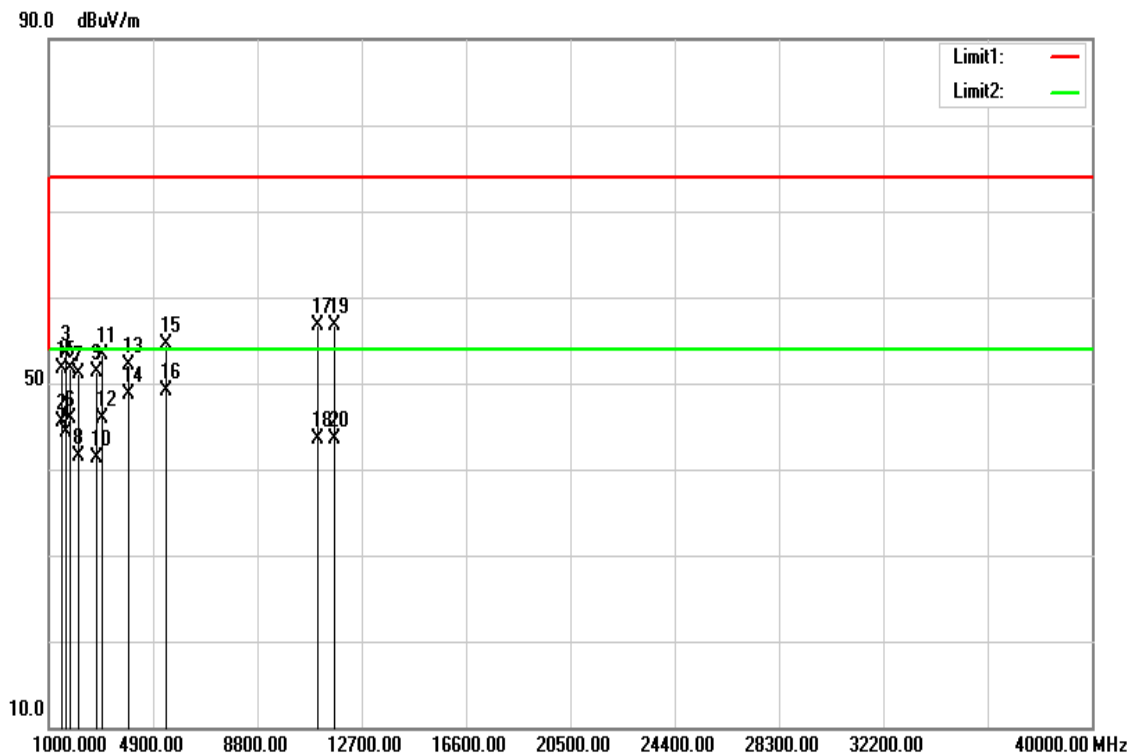

No.	Frequency (MHz)	Reading (dBuV)	Correction Factor (dB/m)	Result (dBuV/m)	Limit (dBuV/m)	Margin (dB)	Height (cm)	Degree (°)	Remark
1	1484.500	70.59	-18.97	51.62	74.00	-22.38	200	310	peak
2	1484.500	64.40	-18.97	45.43	54.00	-8.57	200	310	AVG
3	1603.500	71.57	-18.05	53.52	74.00	-20.48	100	220	peak
4	1603.500	62.32	-18.05	44.27	54.00	-9.73	100	220	AVG
5	1782.000	68.13	-16.50	51.63	74.00	-22.37	100	68	peak
6	1782.000	62.39	-16.50	45.89	54.00	-8.11	100	68	AVG
7	2079.500	65.62	-14.52	51.10	74.00	-22.90	100	5	peak
8	2079.500	56.03	-14.52	41.51	54.00	-12.49	100	5	AVG
9	2759.500	64.64	-13.39	51.25	74.00	-22.75	100	188	peak



Report No.: T190308L01-F

10	2759.500	54.78	-13.39	41.39	54.00	-12.61	100	188	AVG
11	2963.500	66.07	-12.84	53.23	74.00	-20.77	100	348	peak
12	2963.500	58.71	-12.84	45.87	54.00	-8.13	100	348	AVG
13	4000.500	63.60	-11.45	52.15	74.00	-21.85	200	189	peak
14	4000.500	60.20	-11.45	48.75	54.00	-5.25	200	189	AVG
15	5403.000	62.48	-7.93	54.55	74.00	-19.45	100	245	peak
16	5403.000	57.09	-7.93	49.16	54.00	-4.84	100	245	AVG
17	11055.500	53.80	2.88	56.68	74.00	-17.32	300	252	peak
18	11055.500	40.63	2.88	43.51	54.00	-10.49	300	252	AVG
19	11667.500	52.93	3.73	56.66	74.00	-17.34	300	303	peak
20	11667.500	39.77	3.73	43.50	54.00	-10.50	300	303	AVG

**REMARKS:**

1. The other emission levels were very low against the limit.
2. Margin (dB) = Result (dBuV/m) – Limit (dBuV/m)

Report No.: T190308L01-F

<b>Model no.</b>	HSN-C04C	<b>Test Mode</b>	Mode 17
<b>Environmental Conditions</b>	26°C, 60% RH	<b>Test Date</b>	2019/4/17
<b>Antenna Pole</b>	Vertical	<b>Antenna Distance</b>	3m
<b>Highest frequency generated or used</b>	1.6GHz	<b>Upper frequency</b>	8GHz
<b>Detector Function</b>	Peak & Average	<b>Tested by</b>	Rex Kuo
<b>6dB Bandwidth</b>	1 MHz	<b>Identifier number</b>	TCOP RF site 17

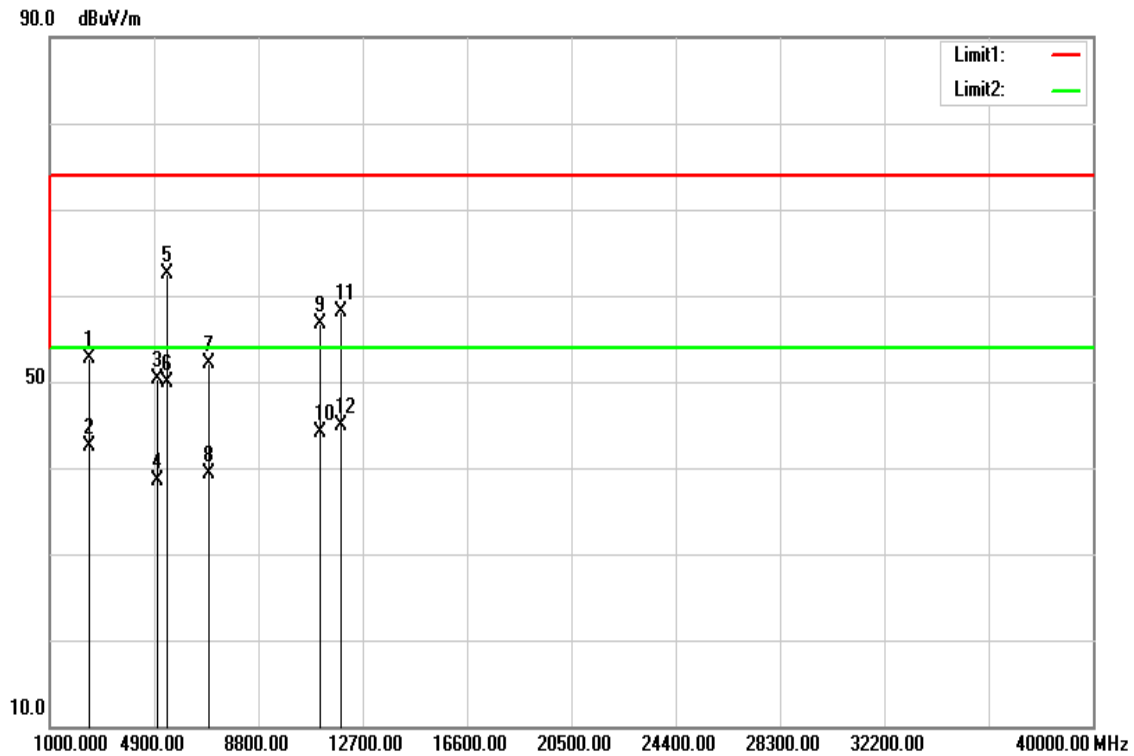

No.	Frequency (MHz)	Reading (dBuV)	Correction Factor (dB/m)	Result (dBuV/m)	Limit (dBuV/m)	Margin (dB)	Height (cm)	Degree (°)	Remark
1	2453.500	66.77	-14.14	52.63	74.00	-21.37	100	213	peak
2	2453.500	56.60	-14.14	42.46	54.00	-11.54	100	213	AVG
3	4986.500	59.03	-8.66	50.37	74.00	-23.63	100	76	peak
4	4986.500	47.11	-8.66	38.45	54.00	-15.55	100	76	AVG
5	5403.000	69.93	-7.51	62.42	74.00	-11.58	100	84	peak
6	5403.000	57.44	-7.51	49.93	54.00	-4.07	100	84	AVG
7	6907.500	55.80	-3.69	52.11	74.00	-21.89	200	72	peak
8	6907.500	42.94	-3.69	39.25	54.00	-14.75	200	72	AVG
9	11081.000	53.36	3.38	56.74	74.00	-17.26	300	45	peak



Report No.: T190308L01-F

10	11081.000	40.75	3.38	44.13	54.00	-9.87	300	45	AVG
11	11854.500	53.65	4.51	58.16	74.00	-15.84	100	167	peak
12	11854.500	40.42	4.51	44.93	54.00	-9.07	100	167	AVG

**REMARKS:**

1. The other emission levels were very low against the limit.
2. Margin (dB) = Result (dBuV/m) – Limit (dBuV/m)

<b>Model no.</b>	HSN-C04C	<b>Test Mode</b>	Mode 17
<b>Environmental Conditions</b>	26°C, 60% RH	<b>Test Date</b>	2019/4/17
<b>Antenna Pole</b>	Horizontal	<b>Antenna Distance</b>	3m
<b>Highest frequency generated or used</b>	1.6GHz	<b>Upper frequency</b>	8GHz
<b>Detector Function</b>	Peak & Average	<b>Tested by</b>	Rex Kuo
<b>6dB Bandwidth</b>	1 MHz	<b>Identifier number</b>	TCOP RF site 17

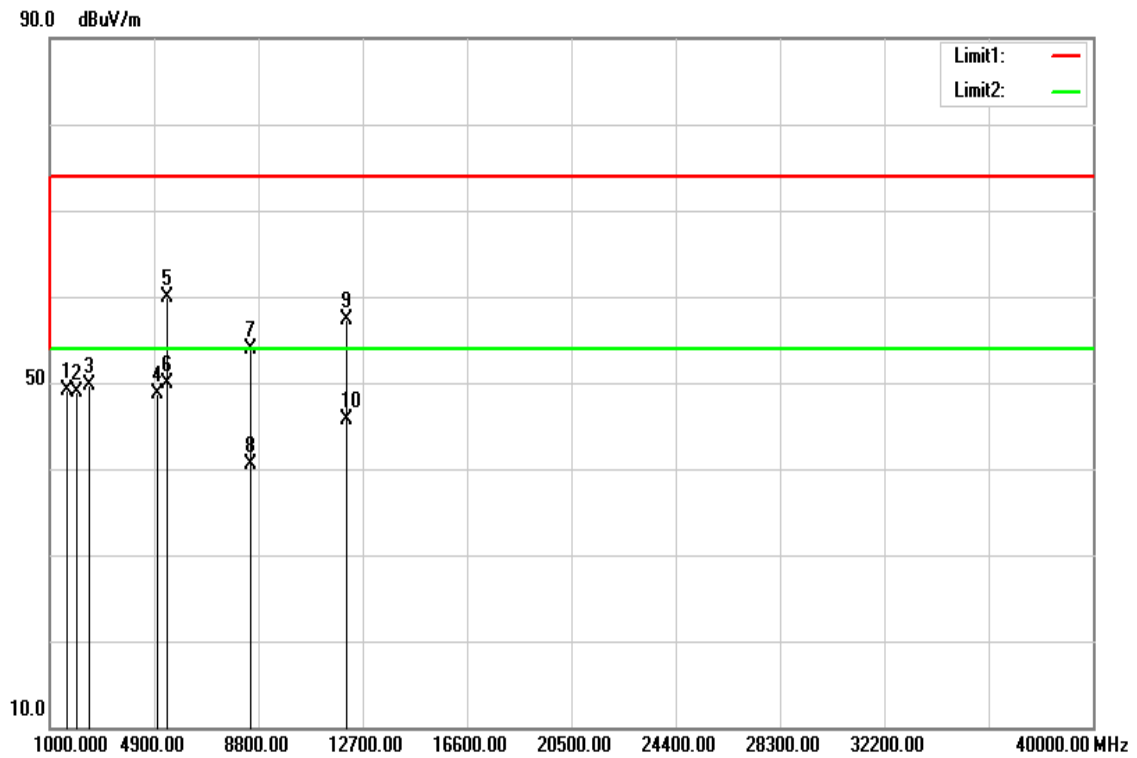

No.	Frequency (MHz)	Reading (dBuV)	Correction Factor (dB/m)	Result (dBuV/m)	Limit (dBuV/m)	Margin (dB)	Height (cm)	Degree (°)	Remark
1	1637.500	67.37	-18.33	49.04	74.00	-24.96	200	174	peak
2	2003.000	63.89	-15.01	48.88	74.00	-25.12	218	0	peak
3	2453.500	63.90	-14.14	49.76	74.00	-24.24	101	360	peak
4	4986.500	57.32	-8.66	48.66	74.00	-25.34	272	0	peak
5	5403.000	67.40	-7.51	59.89	74.00	-14.11	100	284	peak
6	5403.000	57.47	-7.51	49.96	54.00	-4.04	100	284	AVG
7	8480.000	56.84	-2.89	53.95	74.00	-20.05	200	197	peak
8	8480.000	43.30	-2.89	40.41	54.00	-13.59	200	197	AVG
9	12041.500	52.71	4.62	57.33	74.00	-16.67	300	360	peak
10	12041.500	41.01	4.62	45.63	54.00	-8.37	300	360	AVG

**REMARKS:**

1. The other emission levels were very low against the limit.
2. Margin (dB) = Result (dBuV/m) – Limit (dBuV/m)



## 8 PHOTOGRAPHS OF THE TEST CONFIGURATION CONDUCTED EMISSION TEST Mode 16, 17



### RADIATED EMISSION TEST

Below 1GHz

Mode 16, 17

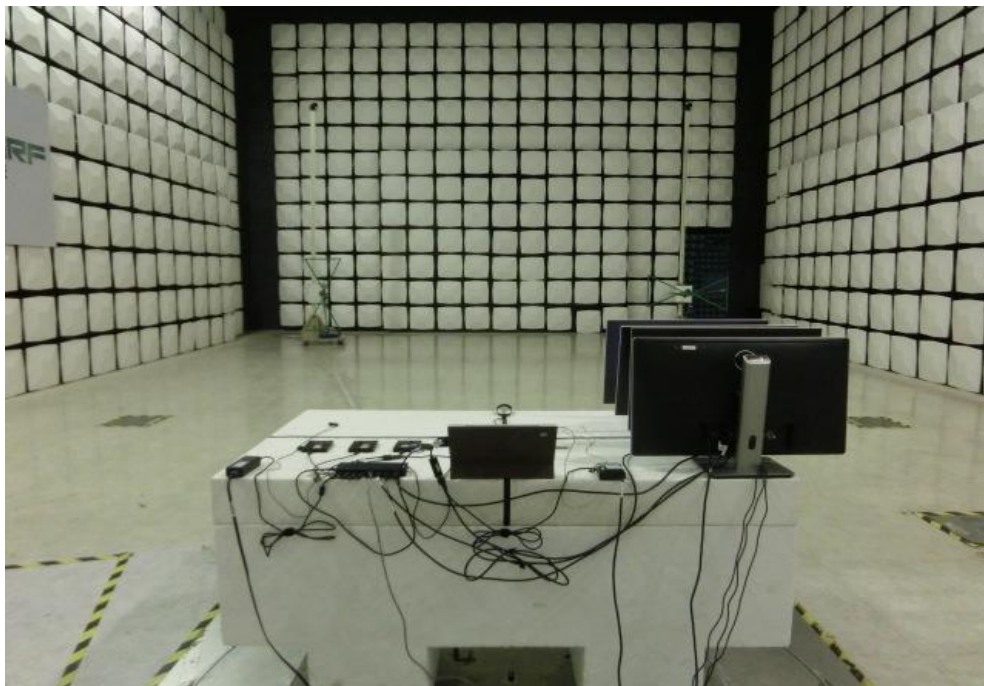
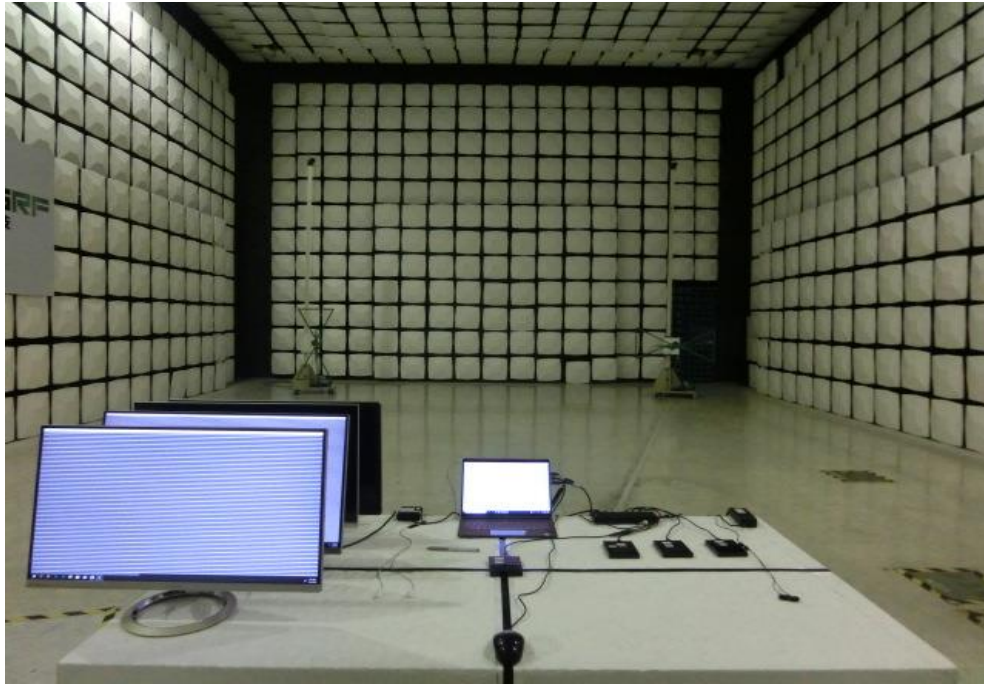

**Above 1GHz  
Mode 16, 17**

