

## FCC Test Report

### (PART 90S)

**Report No.:** RF190326C28A

**FCC ID:** B94HNC04PD

**Test Model:** HSN-C04C

**Received Date:** Apr. 09, 2019

**Test Date:** Apr. 21, 2019 ~ Apr. 26, 2019

**Issued Date:** May 07, 2019

**Applicant:** HP Inc.

**Address:** 3390 East Harmony Road, Fort Collins Colorado, 80528 United States

**Issued By:** Bureau Veritas Consumer Products Services (H.K.) Ltd., Taoyuan Branch

**Lab Address:** No. 47-2, 14th Ling, Chia Pau Vil., Lin Kou Dist., New Taipei City, Taiwan  
( R.O.C )

**Test Location:** No. 19, Hwa Ya 2nd Rd, Wen Hwa Vil, Kwei Shan Dist., Taoyuan City  
33383, Taiwan (R.O.C)

**FCC Registration /  
Designation Number:** 788550 / TW0003



This report is for your exclusive use. Any copying or replication of this report to or for any other person or entity, or use of our name or trademark, is permitted only with our prior written permission. This report sets forth our findings solely with respect to the test samples identified herein. The results set forth in this report are not indicative or representative of the quality or characteristics of the lot from which a test sample was taken or any similar or identical product unless specifically and expressly noted. Our report includes all of the tests requested by you and the results thereof based upon the information that you provided to us. You have 60 days from date of issuance of this report to notify us of any material error or omission caused by our negligence, provided, however, that such notice shall be in writing and shall specifically address the issue you wish to raise. A failure to raise such issue within the prescribed time shall constitute your unqualified acceptance of the completeness of this report, the tests conducted and the correctness of the report contents. Unless specifically mentioned, the uncertainty of measurement has been explicitly taken into account to declare the compliance or non-compliance to the specification. The report must not be used by the client to claim product certification, approval, or endorsement by TAF or any government agencies.

## Table of Contents

<b>Release Control Record .....</b>	<b>3</b>
<b>1 Certificate of Conformity .....</b>	<b>4</b>
<b>2 Summary of Test Results .....</b>	<b>5</b>
2.1 Measurement Uncertainty .....	5
2.2 Test Site and Instruments .....	6
<b>3 General Information .....</b>	<b>8</b>
3.1 General Description of EUT .....	8
3.2 Configuration of System under Test .....	9
3.2.1 Description of Support Units .....	9
3.3 Test Mode Applicability and Tested Channel Detail .....	10
3.4 EUT Operating Conditions .....	11
3.5 General Description of Applied Standards .....	11
<b>4 Test Types and Results .....</b>	<b>12</b>
4.1 Output Power Measurement .....	12
4.1.1 Limits of Output Power Measurement .....	12
4.1.2 Test Procedures .....	12
4.1.3 Test Setup .....	13
4.1.4 Test Results .....	14
4.2 Radiated Emission Measurement .....	17
4.2.1 Limits of Radiated Emission Measurement .....	17
4.2.2 Test Procedure .....	17
4.2.3 Deviation from Test Standard .....	17
4.2.4 Test Setup .....	18
4.2.5 Test Results .....	19
<b>5 Pictures of Test Arrangements .....</b>	<b>33</b>
<b>Appendix – Information of the Testing Laboratories .....</b>	<b>34</b>

### Release Control Record

Issue No.	Description	Date Issued
RF190326C28A	Original Release	May 07, 2019

## 1 Certificate of Conformity

**Product:** Tablet  
**Brand:** HP  
**Test Model:** HSN-C04C  
**Sample Status:** Engineering Sample  
**Applicant:** HP Inc.  
**Test Date:** Apr. 21, 2019 ~ Apr. 26, 2019  
**Standards:** FCC Part 90, Subpart S  
FCC Part 2

The above equipment has been tested by **Bureau Veritas Consumer Products Services (H.K.) Ltd., Taoyuan Branch**, and found compliance with the requirement of the above standards. The test record, data evaluation & Equipment Under Test (EUT) configurations represented herein are true and accurate accounts of the measurements of the sample's RF characteristics under the conditions specified in this report.

**Prepared by :** Rona Chen, **Date:** May 07, 2019  
Rona Chen / Specialist

**Approved by :** Dylan Chiou, **Date:** May 07, 2019  
Dylan Chiou / Project Engineer

## 2 Summary of Test Results

Applied Standard: FCC Part 90 & Part 2 (LTE 26)			
FCC Clause	Test Item	Result	Remarks
2.1046 90.635 (b)	Effective Radiated Power	Pass	Meet the requirement of limit.
2.1047	Modulation Characteristics	N/A	Refer to Note
2.1055 90.213	Frequency Stability	N/A	Refer to Note
2.1049 90.209	Occupied Bandwidth	N/A	Refer to Note
2.1051 90.210	Emission Masks	N/A	Refer to Note
2.1051 90.691	Conducted Spurious Emissions	N/A	Refer to Note
2.1053 90.691	Radiated Spurious Emissions	Pass	Meet the requirement of limit. Minimum passing margin is -33.25 dB at 2457.00 MHz.

### Note:

- This report is a partial report. Therefore, only test item of Effective Radiated Power and Radiated Spurious Emissions tests were performed for this report. Other testing data please refer to BV CPS report no.: RF170106C02-5 for module (Brand: Fibocom, Model: L850-GL)
- Determining compliance based on the results of the compliance measurement, not taking into account measurement instrumentation uncertainty.

### 2.1 Measurement Uncertainty

Where relevant, the following measurement uncertainty levels have been estimated for tests performed on the EUT as specified in CISPR 16-4-2:

Measurement	Frequency	Expanded Uncertainty (k=2) (±)
Radiated Emissions up to 1 GHz	9 kHz ~ 30 MHz	3.04 dB
	30 MHz ~ 200 MHz	2.93 dB
	200 MHz ~ 1000 MHz	2.95 dB
Radiated Emissions above 1 GHz	1 GHz ~ 18 GHz	2.26 dB
	18 GHz ~ 40 GHz	1.94 dB

## 2.2 Test Site and Instruments

Description & Manufacturer	Model No.	Serial No.	Date of Calibration	Due Date of Calibration
Test Receiver Agilent	N9038A	MY51210203	Mar. 18, 2019	Mar. 17, 2020
Spectrum Analyzer Agilent	N9010A	MY52220314	Dec. 13, 2018	Dec. 12, 2019
Spectrum Analyzer ROHDE & SCHWARZ	FSU43	100115	Jan. 21, 2019	Jan. 20, 2020
Spectrum Analyzer ROHDE & SCHWARZ	FSW26	102023	Oct. 11, 2018	Oct. 10, 2019
HORN Antenna SCHWARZBECK	BBHA 9120 D	9120D-969	Nov. 25, 2018	Nov. 24, 2019
BILOG Antenna SCHWARZBECK	VULB9168	9168-472	Nov. 23, 2018	Nov. 22, 2019
Double Ridge Guide Horn Antenna EMCO	3115	5619	Nov. 25, 2018	Nov. 24, 2019
BILOG Antenna SCHWARZBECK	VULB 9168	9168-153	Nov. 23, 2018	Nov. 22, 2019
Fixed Attenuator Mini-Circuits	MDCS18N-10	MDCS18N-10-01	Apr. 15, 2019	Apr. 14, 2020
MXG Vector signal generator Agilent	N5182B	MY53050430	Nov. 19, 2018	Nov. 18, 2019
Preamplifier EMCI	EMC 012645	980115	Oct. 12, 2018	Oct. 11, 2019
Preamplifier EMCI	EMC 330H	980112	Oct. 12, 2018	Oct. 11, 2019
RF Coaxial Cable HUBER+SUHNNER	EMC104-SM-SM-800 0&3000	140811+170717	Oct. 12, 2018	Oct. 11, 2019
RF Coaxial Cable HUBER+SUHNNER	SUCOFLEX 104	EMC104-SM-SM-1 000(140807)	Oct. 12, 2018	Oct. 11, 2019
RF Coaxial Cable WOKEN	8D-FB	Cable-Ch10-01	Oct. 12, 2018	Oct. 11, 2019
Boresight Antenna Fixture	FBA-01	FBA-SIP01	NA	NA
Software BV ADT	E3 6.120103	NA	NA	NA
Antenna Tower MF	MFA-440H	NA	NA	NA
Turn Table MF	MFT-201SS	NA	NA	NA
Antenna Tower & Turn Table Controller MF	MF-7802	NA	NA	NA
Communications Tester-Wireless Agilent	8960 Series 10	MY53201073	Jun. 28, 2017	Jun. 27, 2019
Radio Communication Analyzer Anritsu	MT8820C	6201300640	Aug. 16, 2017	Aug. 15, 2019
Temperature & Humidity Chamber	GTH-120-40-CP-AR	MAA1306-019	Sep. 05, 2018	Sep. 04, 2019
DC Power Supply Topward	33010D	807748	NA	NA

- Note:
1. The calibration interval of the above test instruments is 12 / 24 months and the calibrations are traceable to NML/ROC and NIST/USA.
  2. The test was performed in HwaYa Chamber 10.
  3. The IC Site Registration No. is 7450F-10.

### 3 General Information

#### 3.1 General Description of EUT

<b>Product</b>	Tablet	
<b>Brand</b>	HP	
<b>Test Model</b>	HSN-C04C	
<b>Status of EUT</b>	Engineering Sample	
<b>Power Supply Rating</b>	7.7 Vdc (Li-ion battery) 20 Vdc (Adapter)	
<b>Modulation Type</b>	LTE	QPSK, 16QAM
<b>Frequency Range</b>	LTE Band 26 (Channel Bandwidth: 1.4 MHz)	814.7 ~ 823.3 MHz
	LTE Band 26 (Channel Bandwidth: 3 MHz)	815.5 ~ 822.5 MHz
	LTE Band 26 (Channel Bandwidth: 5 MHz)	816.5 ~ 821.5 MHz
	LTE Band 26 (Channel Bandwidth: 10 MHz)	819 MHz
<b>Max. ERP Power</b>	LTE Band 26 (Channel Bandwidth: 1.4 MHz)	80.35 mW
	LTE Band 26 (Channel Bandwidth: 3 MHz)	84.53 mW
	LTE Band 26 (Channel Bandwidth: 5 MHz)	92.47 mW
	LTE Band 26 (Channel Bandwidth: 10 MHz)	97.50 mW
<b>Antenna Type</b>	PIFA Antenna	
<b>Accessory Device</b>	Refer to Note as below	
<b>Data Cable Supplied</b>	Refer to Note as below	

Note:

1. The WWAN module (Brand: Fibocom, Model: L850-GL) was installed in EUT.
2. The EUT contains following accessory devices.

Product	Brand	Model	Description
Adapter	AcBel	TPN-AA03	I/P: 100-240 Vac, 50-60 Hz, 1500 mA O/P: 20 Vdc, 3.25 A
Battery	Dynapack	HSTNN-DB9E	7.7 Vdc, 5950 mAh
Keyboard 1	Primax	HSN-P01K	--
Keyboard 2	Cosmo	HSN-C01K	--
BT/WLAN Module	Intel® Wi-Fi 6 AX200	AX200D2WL	--
LTE Module	Fibocom	L850-GL	--

3. The antenna information of EUT is listed as below.

Ant. Type	Manufacturer	Parts Number	WWAN Antenna Gain (dBi)
			LTE 26
PIFA	INPAQ	Main Antenna: WA-P-LTE15-02-001 (DC330029D20) Aux. Antenna: WA-P-LTE15-02-002 (DC330029D30) WA-P-LTE11-02-003 (DC330029D40) WA-P-LTE11-02-004 (DC330029D50)	0.20

4. The above EUT information is declared by manufacturer and for more detailed features description, please refers to the manufacturer's specifications or user's manual.



### 3.2 Configuration of System under Test

#### <Radiated Emission Test>

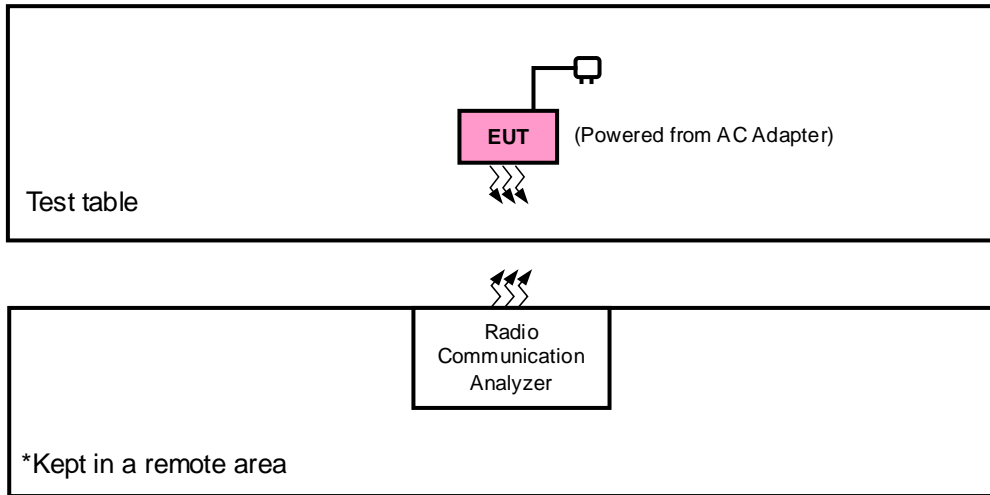

#### <E.R.P. Test>

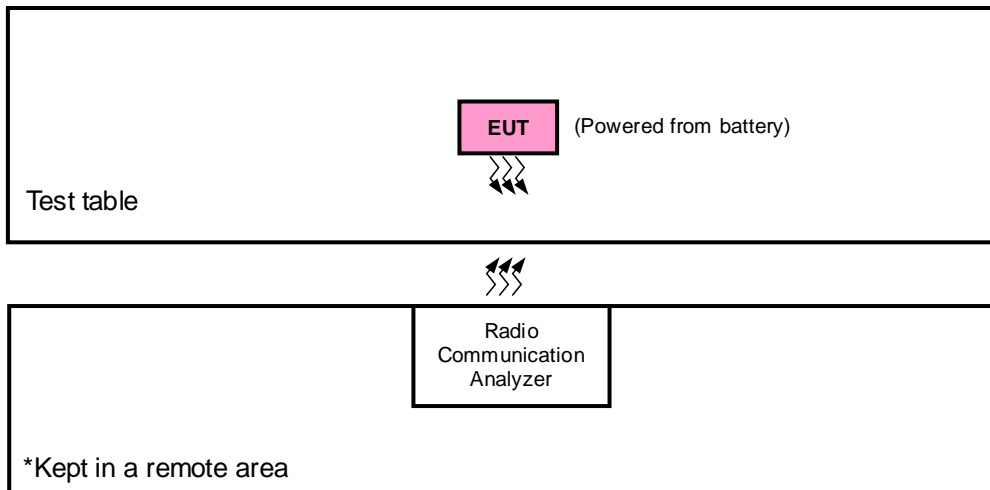

#### 3.2.1 Description of Support Units

The EUT has been tested as an independent unit together with other necessary accessories or support units.

### 3.3 Test Mode Applicability and Tested Channel Detail

Pre-Scan has been conducted to determine the worst-case mode from all possible combinations between available modulations, data rates, XYZ axis & NB Mode, and antenna ports.

The worst case was found when positioned as the table below. Following channel(s) was (were) selected for the final test as listed below:

Band	ERP	Radiated Emission
LTE Band 26	X-plane	Z-axis

#### LTE Band 26

EUT Configure Mode	Test Item	Available Channel	Tested Channel	Channel Bandwidth	Modulation	Mode
-	ERP	26697 to 26783	26697, 26740, 26783	1.4 MHz	QPSK, 16QAM	1 RB / 0 RB Offset
		26705 to 26775	26705, 26740, 26775	3 MHz	QPSK, 16QAM	1 RB / 0 RB Offset
		26715 to 26765	26715, 26740, 26765	5 MHz	QPSK, 16QAM	1 RB / 0 RB Offset
		26740	26740	10 MHz	QPSK, 16QAM	1 RB / 0 RB Offset
-	Radiated Emission	26697 to 26783	26697, 26740, 26783	1.4 MHz	QPSK	1 RB / 0 RB Offset
		26715 to 26765	26715, 26740, 26765	5 MHz	QPSK	1 RB / 0 RB Offset
		26740	26740	10 MHz	QPSK	1 RB / 0 RB Offset

#### Note:

1. This device was tested under all bandwidths, RB configurations and modulations. The worst case was found in QPSK modulation.
2. For radiated emission above 1 GHz, according to 3GPP 36.521 Section 6.6.3.1.4, choose the lowest, 5 MHz & highest channel bandwidth for final test.

#### Test Condition:

Test Item	Environmental Conditions	Input Power	Tested By
ERP	25 deg. C, 65 % RH	3.3 Vdc	Jisyong Wang
Radiated Emission	25 deg. C, 65 % RH	120 Vac, 60 Hz (System)	Jisyong Wang

### **3.4 EUT Operating Conditions**

The EUT makes a call to the communication simulator. The communication simulator station system controlled a EUT to export maximum output power under transmission mode and specific channel frequency

### **3.5 General Description of Applied Standards**

The EUT is a RF Product. According to the specifications of the manufacturer, it must comply with the requirements of the following standards:

**FCC 47 CFR Part 2**

**FCC 47 CFR Part 90**

**KDB 971168 D01 Power Meas License Digital Systems v03r01**

**KDB 971168 D02 Misc Rev Approv License Devices v02r01**

**ANSI/TIA/EIA-603-E 2016**

**ANSI 63.26-2015**

**Note:** All test items have been performed and recorded as per the above standards.

## 4 Test Types and Results

### 4.1 Output Power Measurement

#### 4.1.1 Limits of Output Power Measurement

The maximum output power of the transmitter for mobile stations is 100 watts (20 dBw) ERP.

#### 4.1.2 Test Procedures

##### **EIRP / ERP Measurement:**

- a. All measurements were done at low, middle and high operational frequency range. RBW and VBW is 10 MHz for LTE mode.
- b. Substitution method is used for E.I.R.P measurement. In the semi-anechoic chamber, EUT placed on the 0.8 m (below or equal 1 GHz) and/or 1.5 m (above 1 GHz) height of Turn Table, rotated the table around 360 degrees to search the maximum radiation power and receiver antenna shall be rotated vertical and horizontal polarization and moved height from 1 m to 4 m to find the maximum polar radiated power. The "Read Value" is the spectrum reading the maximum power value.
- c. The substitution horn antenna is substituted for EUT at the same position and signals generator export the CW signal to the substitution antenna via a tx cable. Rotated the Turn Table and moved receiving antenna to find the maximum radiation power. Adjust output power level of S.G to get a Value of spectrum reading equal to "Read Value" of step b. Record the power level of S.G.
- d.  $EIRP = \text{Output power level of S.G} - \text{TX cable loss} + \text{Antenna gain of substitution horn}$ . E.R.P power can be calculated form E.I.R.P power by subtracting the gain of dipole,  $E.R.P \text{ power} = E.I.P.R \text{ power} - 2.15 \text{ dB}$ .

##### **Conducted Power Measurement:**

- a. The EUT was set up for the maximum power with LTE link data modulation and link up with simulator.
- b. Set the EUT to transmit under low, middle and high channel and record the power level shown on simulator.

### 4.1.3 Test Setup

#### EIRP / ERP Measurement:

<Radiated Emission below or equal 1 GHz>

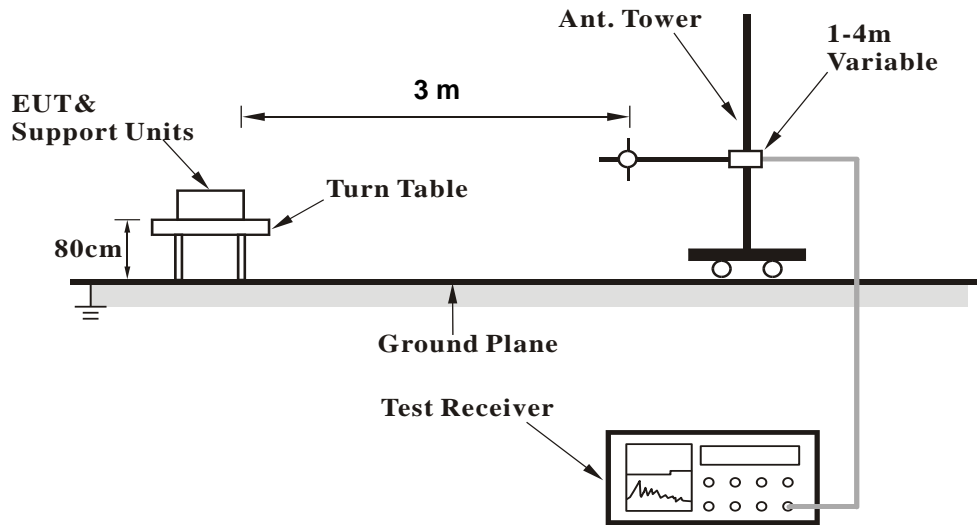

<Radiated Emission above 1 GHz>

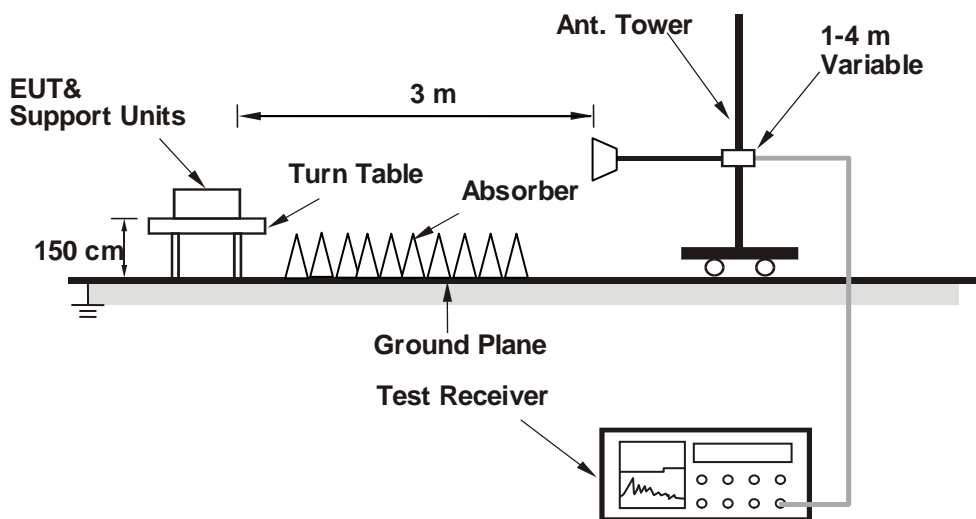

For the actual test configuration, please refer to the attached file (Test Setup Photo).

#### Conducted Power Measurement:

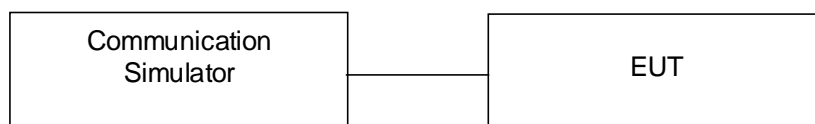

4.1.4 Test Results

Conducted Output Power (dBm)

LTE Band 26																
BW	MCS Index	RB Size	RB Offset	Mid			3GPP MPR (dB)	BW	MCS Index	RB Size	RB Offset	Low	Mid	High	3GPP MPR (dB)	
				Channel	26740							26715	26740	26765		
				Frequency (MHz)	819.0							816.5	819.0	821.5		
10M	QPSK	1	0		22.77		0	5M	QPSK	1	0	22.62	22.77	22.82	0	
		1	24		22.80		0			1	12	22.71	22.80	22.80	0	
		1	49		22.69		0			1	24	22.54	22.69	22.77	0	
		25	0		21.86		1			12	0	21.67	21.86	21.89	1	
		25	12		21.76		1			12	6	21.84	21.76	21.85	1	
		25	25		21.81		1			12	13	21.69	21.81	21.81	1	
		50	0		21.74		1			25	0	21.80	21.74	21.82	1	
	16QAM	1	0		21.81		1		16QAM	1	0	21.70	21.81	21.83	1	
		1	24		21.76		1			1	12	21.63	21.76	21.81	1	
		1	49		21.76		1			1	24	21.56	21.76	21.78	1	
		25	0		20.81		2			12	0	20.80	20.81	20.90	2	
		25	12		20.84		2			12	6	20.67	20.84	20.86	2	
		25	25		20.75		2			12	13	20.59	20.75	20.82	2	
		50	0		20.74		2			25	0	20.72	20.74	20.83	2	
BW	MCS Index	RB Size	RB Offset	Low	Mid	High	3GPP MPR (dB)	BW	MCS Index	RB Size	RB Offset	Low	Mid	High	3GPP MPR (dB)	
				Channel	26705	26740						26775	26697	26740		26783
				Frequency (MHz)	815.5	819.0						822.5	814.7	819.0		823.3
3M	QPSK	1	0	22.73	22.77	22.70	0	1.4M	QPSK	1	0	22.63	22.63	22.71	0	
		1	7	22.67	22.76	22.73	0			1	2	22.62	22.75	22.77	0	
		1	14	22.70	22.66	22.70	0			1	5	22.61	22.62	22.75	0	
		8	0	21.72	21.71	21.89	1			3	0	22.81	22.78	22.74	0	
		8	3	21.74	21.72	21.75	1			3	1	22.75	22.68	22.74	0	
		8	7	21.70	21.79	21.68	1			3	3	22.59	22.75	22.81	0	
		15	0	21.61	21.68	21.71	1			6	0	21.70	21.70	21.80	1	
	16QAM	1	0	21.75	21.69	21.74	1		16QAM	1	0	21.75	21.79	21.76	1	
		1	7	21.64	21.74	21.72	1			1	2	21.70	21.76	21.81	1	
		1	14	21.60	21.71	21.70	1			1	5	21.61	21.74	21.69	1	
		8	0	20.76	20.71	20.76	2			3	0	21.78	21.80	21.79	1	
		8	3	20.70	20.74	20.73	2			3	1	21.65	21.75	21.77	1	
		8	7	20.71	20.72	20.81	2			3	3	21.69	21.67	21.75	1	
		15	0	20.67	20.60	20.75	2			6	0	20.70	20.69	20.82	2	

**ERP Power (dBm)**

LTE Band 26							
Channel Bandwidth: 1.4 MHz / QPSK							
Plane	Channel	Frequency (MHz)	Reading (dBm)	Correction Factor (dB)	ERP (dBm)	ERP (mW)	Polarization (H/V)
X	26697	814.7	-10.93	32.01	18.93	78.16	H
	26740	819.0	-10.91	32.11	19.05	<b>80.35</b>	
	26783	823.3	-11.41	32.32	18.76	75.16	
	26697	814.7	-16.57	32.54	13.82	24.10	V
	26740	819.0	-16.46	32.51	13.90	24.55	
	26783	823.3	-16.60	32.51	13.76	23.77	
Channel Bandwidth: 1.4 MHz / 16QAM							
X	26697	814.7	-11.94	32.01	17.92	61.94	H
	26740	819.0	-11.80	32.11	18.16	65.46	
	26783	823.3	-12.42	32.32	17.75	59.57	
	26697	814.7	-17.58	32.54	12.81	19.10	V
	26740	819.0	-17.47	32.51	12.89	19.45	
	26783	823.3	-17.61	32.51	12.75	18.84	

Note: ERP (dBm) = Reading (dBm) + Correction Factor (dB) – 2.15

LTE Band 26							
Channel Bandwidth: 3 MHz / QPSK							
Plane	Channel	Frequency (MHz)	Reading (dBm)	Correction Factor (dB)	ERP (dBm)	ERP (mW)	Polarization (H/V)
X	26705	815.5	-10.69	32.02	19.18	82.79	H
	26740	819.0	-10.69	32.11	19.27	<b>84.53</b>	
	26775	822.5	-11.02	32.18	19.01	79.62	
	26705	815.5	-16.28	32.5	14.07	25.53	V
	26740	819.0	-16.21	32.51	14.15	26.00	
	26775	822.5	-16.31	32.47	14.01	25.18	
Channel Bandwidth: 3 MHz / 16QAM							
X	26705	815.5	-11.72	32.02	18.15	65.31	H
	26740	819.0	-11.57	32.11	18.39	69.02	
	26775	822.5	-12.05	32.18	17.98	62.81	
	26705	815.5	-17.31	32.5	13.04	20.14	V
	26740	819.0	-17.24	32.51	13.12	20.51	
	26775	822.5	-17.34	32.47	12.98	19.86	

Note: ERP (dBm) = Reading (dBm) + Correction Factor (dB) – 2.15

LTE Band 26							
Channel Bandwidth: 5 MHz / QPSK							
Plane	Channel	Frequency (MHz)	Reading (dBm)	Correction Factor (dB)	ERP (dBm)	ERP (mW)	Polarization (H/V)
X	26715	816.5	-10.47	32.04	19.42	87.50	H
	26740	819.0	-10.30	32.11	19.66	<b>92.47</b>	
	26765	821.5	-10.39	31.79	19.25	84.14	
	26715	816.5	-16.06	32.52	14.31	26.98	V
	26740	819.0	-15.97	32.51	14.39	27.48	
	26765	821.5	-15.77	32.17	14.25	26.61	
Channel Bandwidth: 5 MHz / 16QAM							
X	26715	816.5	-11.50	32.04	18.39	69.02	H
	26740	819.0	-11.33	32.11	18.63	72.95	
	26765	821.5	-11.42	31.79	18.22	66.37	
	26715	816.5	-17.09	32.52	13.28	21.28	V
	26740	819.0	-17.00	32.51	13.36	21.68	
	26765	821.5	-16.80	32.17	13.22	20.99	

Note: ERP (dBm) = Reading (dBm) + Correction Factor (dB) – 2.15

LTE Band 26							
Channel Bandwidth: 10 MHz / QPSK							
Plane	Channel	Frequency (MHz)	Reading (dBm)	Correction Factor (dB)	ERP (dBm)	ERP (mW)	Polarization (H/V)
X	26740	819.0	-10.07	32.11	19.89	<b>97.50</b>	H
	26740	819.0	-15.74	32.51	14.62	28.97	V
Channel Bandwidth: 10 MHz / 16QAM							
X	26740	819.0	-11.08	32.11	18.88	77.27	H
	26740	819.0	-16.75	32.51	13.61	22.96	V

Note: ERP (dBm) = Reading (dBm) + Correction Factor (dB) – 2.15



## 4.2 Radiated Emission Measurement

### 4.2.1 Limits of Radiated Emission Measurement

The power of any emission outside a licensee's frequency block shall be attenuated below the transmitter power (P) by at least  $43 + 10 \log (P)$  dB. The limit of emission is equal to -13 dBm.

### 4.2.2 Test Procedure

- a. Substitution method is used for E.I.R.P measurement. In the semi-anechoic chamber, EUT placed on the 0.8 m (below or equal 1 GHz) and/or 1.5 m (above 1 GHz) height of Turn Table, rotated the table around 360 degrees to search the maximum radiation power and receiver antenna shall be rotated vertical and horizontal polarization and moved height from 1 m to 4 m to find the maximum polar radiated power. The "Read Value" is the spectrum reading the maximum power value.
- b. The substitution horn antenna is substituted for EUT at the same position and signals generator export the CW signal to the substitution antenna via a TX cable. Rotated the Turn Table and moved receiving antenna to find the maximum radiation power. Adjust output power level of S.G to get a Value of spectrum reading equal to "Read Value" of step a. Record the power level of S.G.
- c.  $EIRP = \text{Output power level of S.G} - \text{TX cable loss} + \text{Antenna gain of substitution horn}$ .
- d. E.R.P power can be calculated form E.I.R.P power by subtracting the gain of dipole,  $E.R.P \text{ power} = E.I.P.R \text{ power} - 2.15 \text{ dB}$ .

**Note:** The resolution bandwidth of spectrum analyzer is 1 MHz and the video bandwidth is 3 MHz.

### 4.2.3 Deviation from Test Standard

No deviation.

#### 4.2.4 Test Setup

##### <Radiated Emission below or equal 1 GHz>

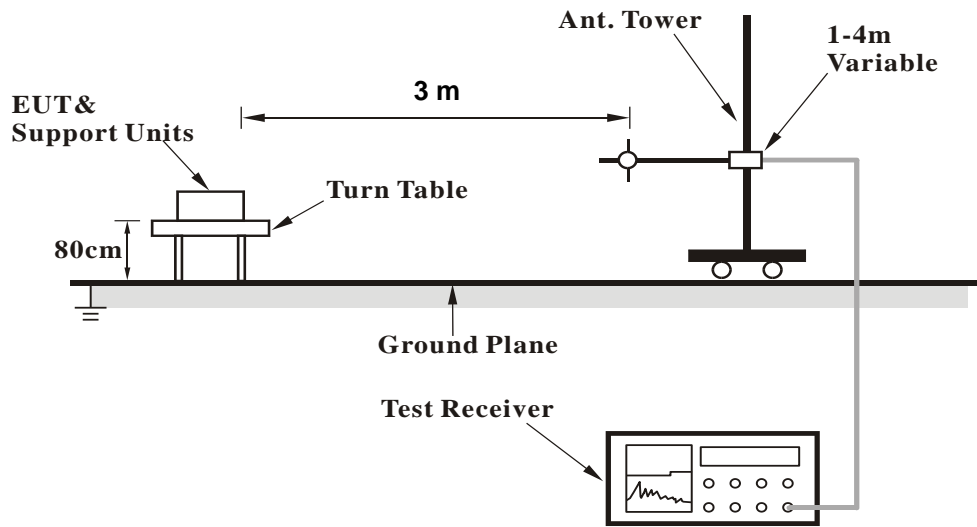

##### <Radiated Emission above 1 GHz>

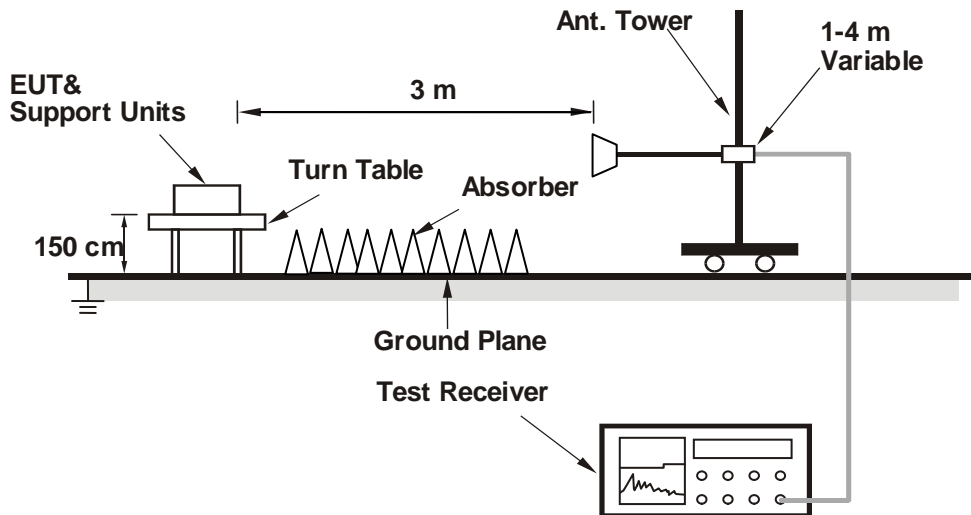

For the actual test configuration, please refer to the attached file (Test Setup Photo).

4.2.5 Test Results

LTE Band 26  
Channel Bandwidth: 1.4 MHz / QPSK  
Low Channel

Bureau Veritas Consumer Products Services Ltd., Taoyuan Branch



A D T

Data: 3

Date: 2019-04-21

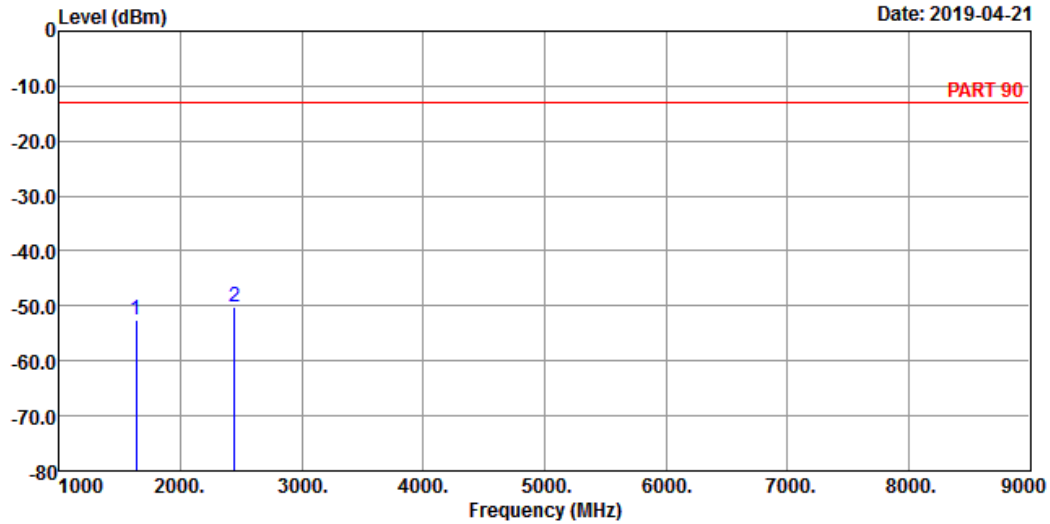

Site : 966 Chamber 5  
Condition: PART 90 HORIZONTAL  
Remak : LTE Band 26 QPSK\_1.4M\_L-CH Link  
Tested by: Jisyong Wang

	Freq	Level	Read Level	Limit	Line Factor	Over Limit	Remark
	MHz	dBm	dBm	dBm	dB	dB	
1	1629.40	-52.69	-37.90	-13.00	-14.79	-39.69	Peak
2 pp	2444.10	-50.25	-39.81	-13.00	-10.44	-37.25	Peak

Bureau Veritas Consumer Products Services Ltd., Taoyuan Branch



A D T

Data: 4

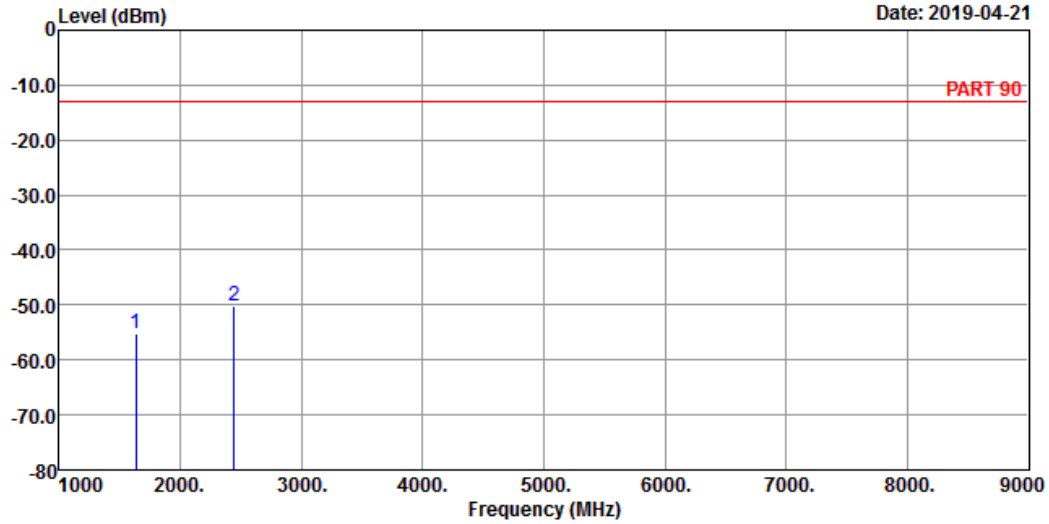

Site : 966 Chamber 5  
 Condition: PART 90 VERTICAL  
 Remak : LTE Band 26 QPSK\_1.4M\_L-CH Link  
 Tested by: Jisyong Wang

	Freq	Level	Read Level	Limit	Line Factor	Over Limit	Remark
	MHz	dBm	dBm	dBm	dB	dB	
1	1629.40	-55.23	-40.44	-13.00	-14.79	-42.23	Peak
2	2444.10	-50.11	-39.67	-13.00	-10.44	-37.11	Peak

Middle Channel

Bureau Veritas Consumer Products Services Ltd., Taoyuan



A D T

Data: 3

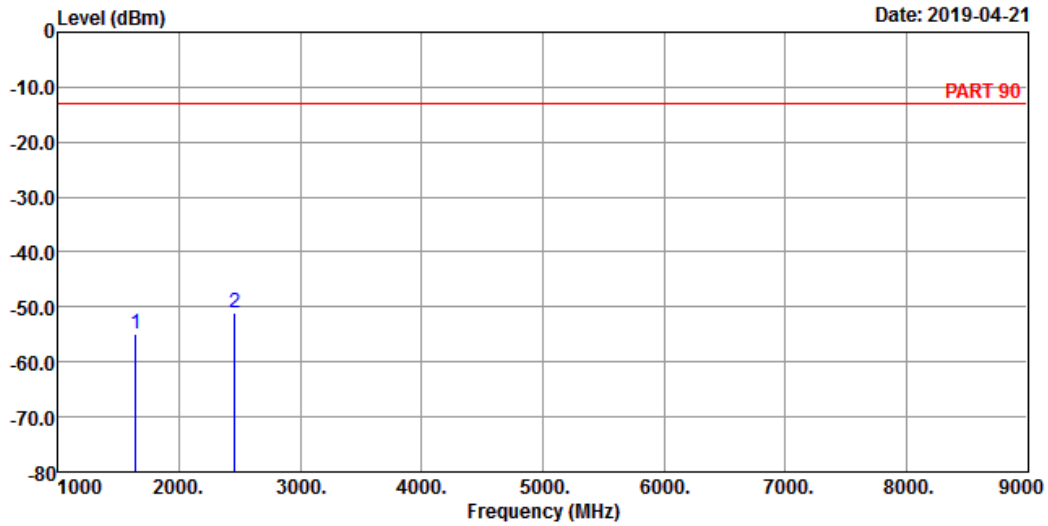

Site : 966 Chamber 5  
 Condition: PART 90 HORIZONTAL  
 Remak : LTE Band 26 QPSK\_1.4M\_M-CH Link  
 Tested by: Jisyong Wang

	Freq	Level	Read Level	Limit	Line Factor	Over Limit	Remark
	MHz	dBm	dBm	dBm	dB	dB	
1	1638.00	-55.02	-40.23	-13.00	-14.79	-42.02	Peak
2 pp	2457.00	-51.11	-40.67	-13.00	-10.44	-38.11	Peak

Bureau Veritas Consumer Products Services Ltd., Taoyuan Branch



A D T

Data: 4

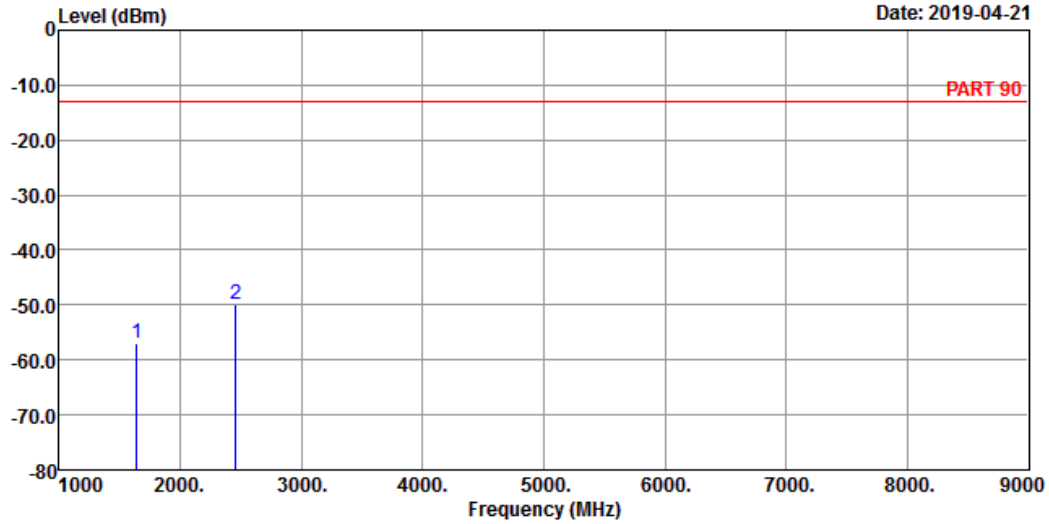

Site : 966 Chamber 5  
 Condition: PART 90 VERTICAL  
 Remak : LTE Band 26 QPSK\_1.4M\_M-CH Link  
 Tested by: Jisyong Wang

	Freq	Level	Read Level	Limit	Line Factor	Over Limit	Remark
	MHz	dBm	dBm	dBm	dB	dB	
1	1638.00	-57.11	-42.32	-13.00	-14.79	-44.11	Peak
2 pp	2457.00	-49.99	-39.55	-13.00	-10.44	-36.99	Peak

## High Channel

Bureau Veritas Consumer Products Services Ltd., Taoyuan Branch



A D T

Data: 3

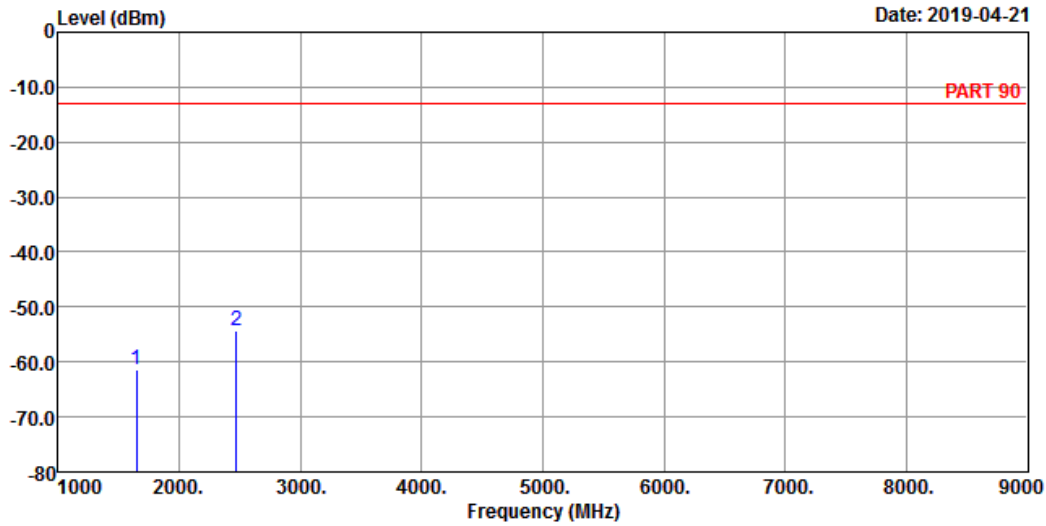

Site : 966 Chamber 5  
 Condition: PART 90 HORIZONTAL  
 Remak : LTE Band 26 QPSK\_1.4M\_H-CH Link  
 Tested by: Jisyong Wang

	Freq	Level	Read Level	Limit	Line Factor	Over Limit	Remark
	MHz	dBm	dBm	dBm	dB	dB	
1	1646.60	-61.52	-46.79	-13.00	-14.73	-48.52	Peak
2	pp 2469.90	-54.23	-43.79	-13.00	-10.44	-41.23	Peak

Bureau Veritas Consumer Products Services Ltd., Taoyuan Branch



A D T

Data: 4

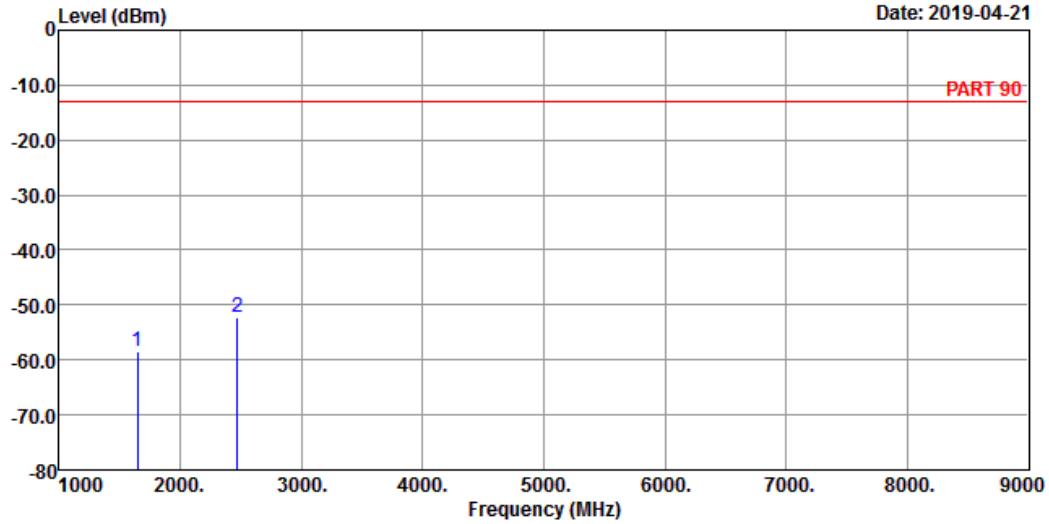

Site : 966 Chamber 5  
 Condition: PART 90 VERTICAL  
 Remak : LTE Band 26 QPSK\_1.4M\_H-CH Link  
 Tested by: Jisyong Wang

	Freq	Level	Read Level	Limit	Line Factor	Over Limit	Remark
	MHz	dBm	dBm	dBm	dB	dB	
1	1646.60	-58.48	-43.75	-13.00	-14.73	-45.48	Peak
2 pp	2469.90	-52.25	-41.81	-13.00	-10.44	-39.25	Peak



Channel Bandwidth: 5 MHz / QPSK  
Low Channel

Bureau Veritas Consumer Products Services Ltd., Taoyuan Branch



A D T

Data: 3

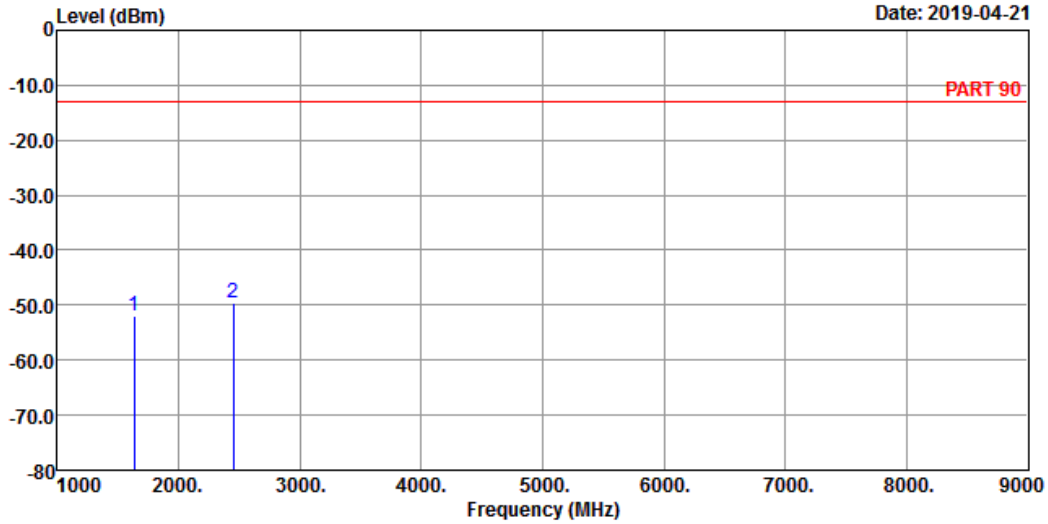

Site : 966 Chamber 5  
Condition: PART 90 HORIZONTAL  
Remak : LTE Band 26 QPSK\_5M\_L-CH Link  
Tested by: Jisyong Wang

	Freq	Level	Read Level	Limit	Line Factor	Over Limit	Remark
	MHz	dBm	dBm	dBm	dB	dB	
1	1633.00	-51.95	-37.16	-13.00	-14.79	-38.95	Peak
2 pp	2449.50	-49.48	-39.04	-13.00	-10.44	-36.48	Peak

Bureau Veritas Consumer Products Services Ltd., Taoyuan Branch



A D T

Data: 4

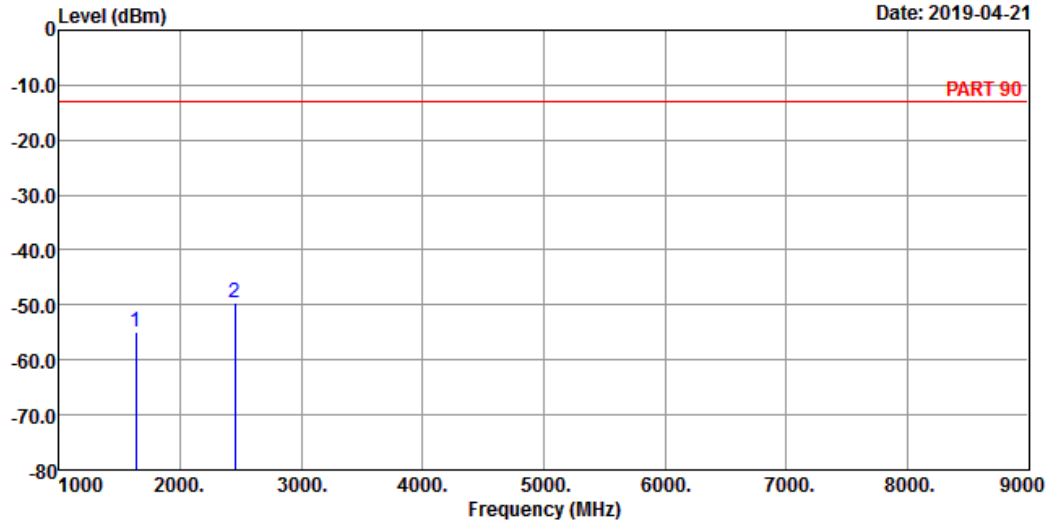

Site : 966 Chamber 5  
 Condition: PART 90 VERTICAL  
 Remak : LTE Band 26 QPSK\_5M\_L-CH Link  
 Tested by: Jisyong Wang

	Freq	Level	Read Level	Limit	Line Factor	Over Limit	Remark
	MHz	dBm	dBm	dBm	dB	dB	
1	1633.00	-54.92	-40.13	-13.00	-14.79	-41.92	Peak
2	2449.50	-49.67	-39.23	-13.00	-10.44	-36.67	Peak

Middle Channel

Bureau Veritas Consumer Products Services Ltd., Taoyuan Branch



A D T

Data: 3

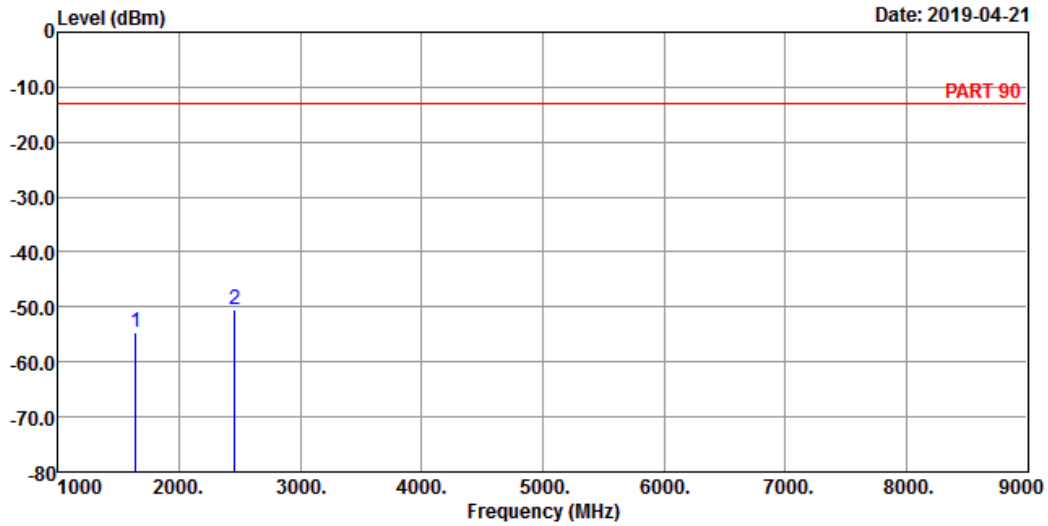

Site : 966 Chamber 5  
 Condition: PART 90 HORIZONTAL  
 Remak : LTE Band 26 QPSK\_5M\_M-CH Link  
 Tested by: Jisyong Wang

	Freq	Level	Read Level	Limit	Line Factor	Over Limit	Remark
	MHz	dBm	dBm	dBm	dB	dB	
1	1638.00	-54.75	-39.96	-13.00	-14.79	-41.75	Peak
2	2457.00	-50.57	-40.13	-13.00	-10.44	-37.57	Peak

Bureau Veritas Consumer Products Services Ltd., Taoyuan Branch



A D T

Data: 4

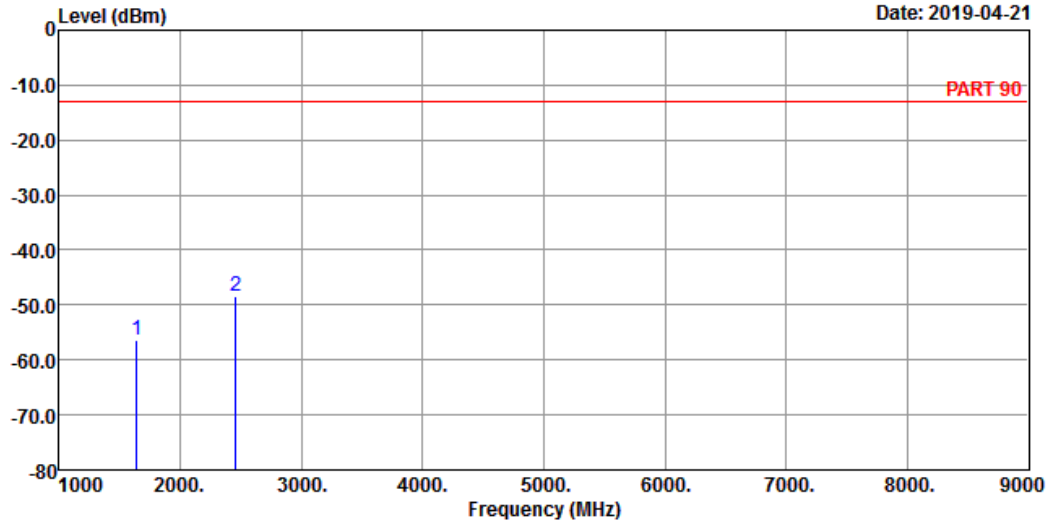

Site : 966 Chamber 5  
 Condition: PART 90 VERTICAL  
 Remak : LTE Band 26 QPSK\_5M\_M-CH Link  
 Tested by: Jisyong Wang

	Freq	Level	Read Level	Limit	Line Factor	Over Limit	Remark
	MHz	dBm	dBm	dBm	dB	dB	
1	1638.00	-56.49	-41.70	-13.00	-14.79	-43.49	Peak
2 pp	2457.00	-48.48	-38.04	-13.00	-10.44	-35.48	Peak

High Channel

Bureau Veritas Consumer Products Services Ltd., Taoyuan Branch



A D T

Data: 3

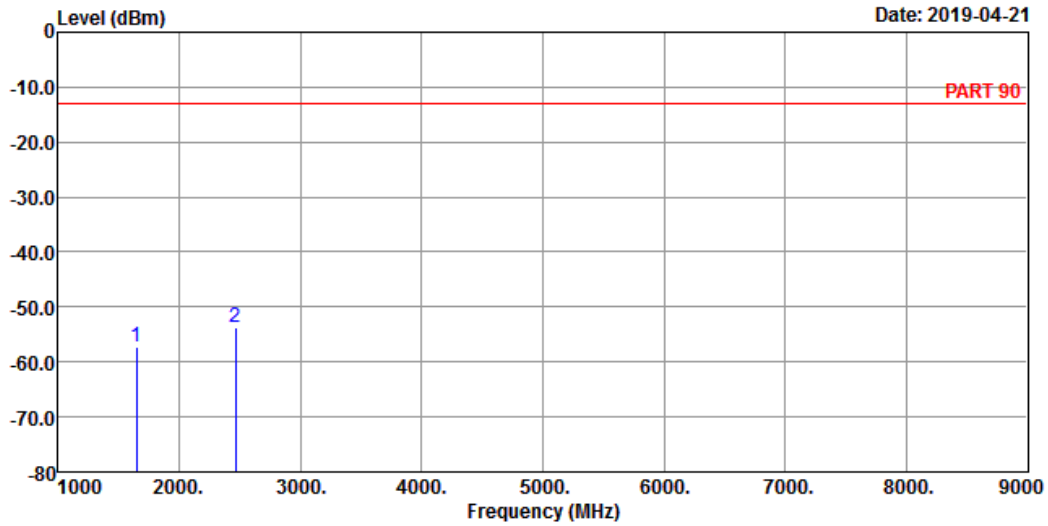

Site : 966 Chamber 5  
 Condition: PART 90 HORIZONTAL  
 Remak : LTE Band 26 QPSK\_5M\_H-CH Link  
 Tested by: Jisyong Wang

	Freq	Level	Read Level	Limit	Line Factor	Over Limit	Remark
	MHz	dBm	dBm	dBm	dB	dB	
1	1643.00	-57.18	-42.45	-13.00	-14.73	-44.18	Peak
2 pp	2464.50	-53.75	-43.31	-13.00	-10.44	-40.75	Peak

Bureau Veritas Consumer Products Services Ltd., Taoyuan Branch



A D T

Data: 4

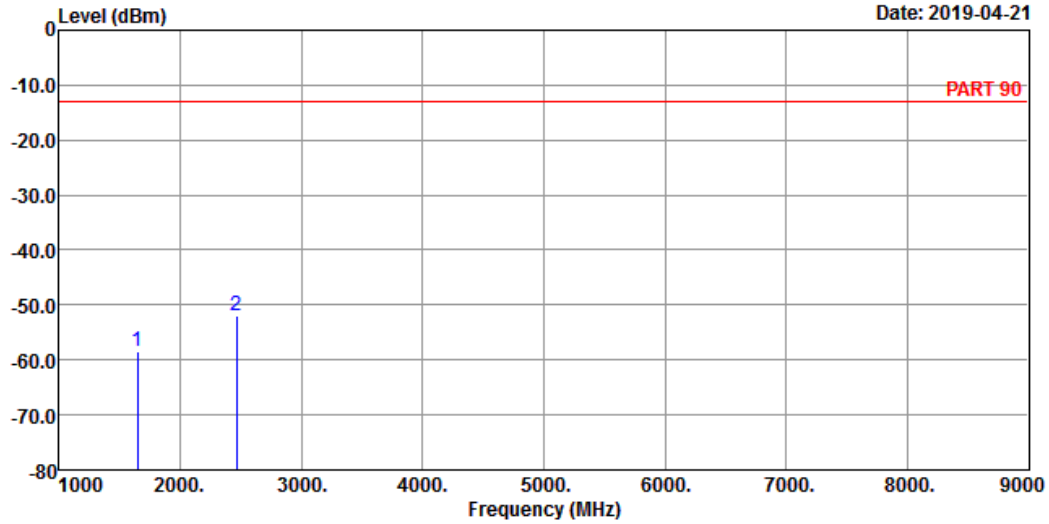

Site : 966 Chamber 5  
 Condition: PART 90 VERTICAL  
 Remak : LTE Band 26 QPSK\_5M\_H-CH Link  
 Tested by: Jisyong Wang

	Freq	Level	Read Level	Limit	Line Factor	Over Limit	Remark
	MHz	dBm	dBm	dBm	dB	dB	
1	1643.00	-58.48	-43.75	-13.00	-14.73	-45.48	Peak
2	2464.50	-51.88	-41.44	-13.00	-10.44	-38.88	Peak

Channel Bandwidth: 10 MHz / QPSK  
Middle Channel

Bureau Veritas Consumer Products Services Ltd., Taoyuan



A D T

Data: 5

Date: 2019-04-21

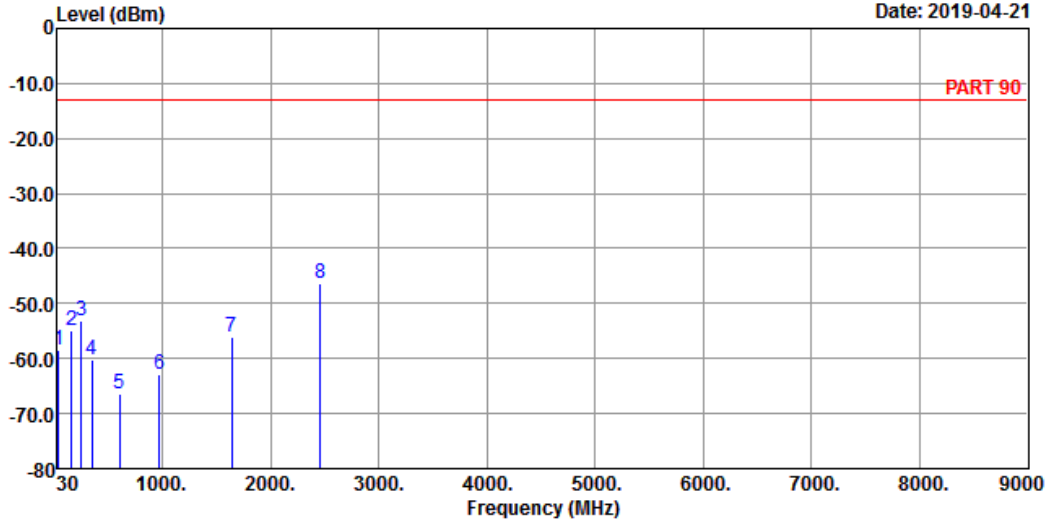

Site : 966 Chamber 5  
Condition: PART 90 HORIZONTAL  
Remak : LTE Band 26 QPSK\_10M\_M-CH Link  
Tested by: Jisyong Wang

	Freq	Level	Read Level	Limit	Line Factor	Over Limit	Remark
	MHz	dBm	dBm	dBm	dB	dB	
1	41.64	-58.36	-57.95	-13.00	-0.41	-45.36	Peak
2	162.89	-54.79	-49.74	-13.00	-5.05	-41.79	Peak
3	248.25	-53.26	-47.19	-13.00	-6.07	-40.26	Peak
4	347.19	-60.33	-54.05	-13.00	-6.28	-47.33	Peak
5	605.21	-66.29	-65.52	-13.00	-0.77	-53.29	Peak
6	968.96	-62.81	-65.29	-13.00	2.48	-49.81	Peak
7	1638.00	-55.99	-41.20	-13.00	-14.79	-42.99	Peak
8 pp	2457.00	-46.25	-35.81	-13.00	-10.44	-33.25	Peak



Data: 6

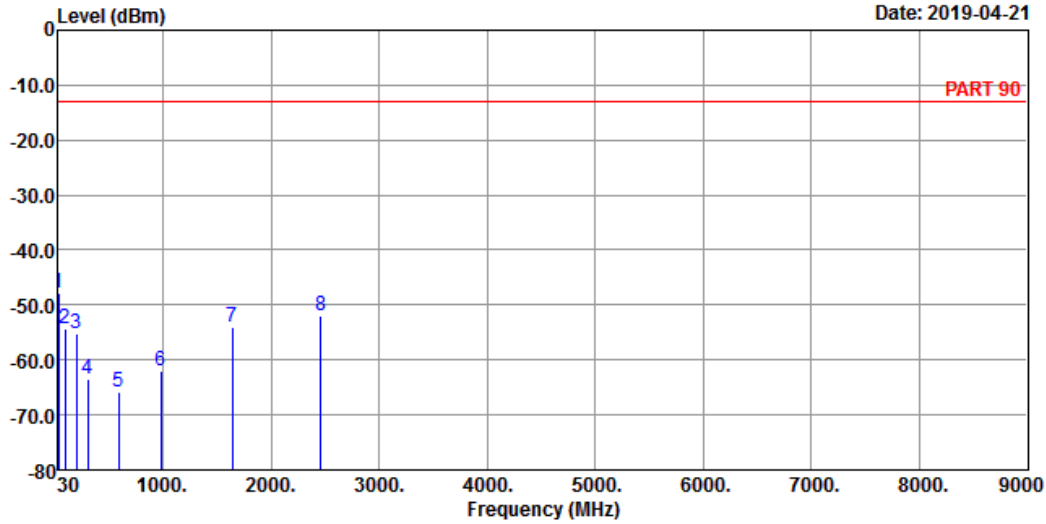

Site : 966 Chamber 5  
 Condition: PART 90 VERTICAL  
 Remak : LTE Band 26 QPSK\_10M\_M-CH Link  
 Tested by: Jisyong Wang

	Freq	Level	Read Level	Limit Line	Factor	Over Limit	Remark
	MHz	dBm	dBm	dBm	dB	dB	
1 pp	34.85	-47.83	-45.76	-13.00	-2.07	-34.83	Peak
2	93.05	-54.31	-43.36	-13.00	-10.95	-41.31	Peak
3	194.90	-55.16	-47.61	-13.00	-7.55	-42.16	Peak
4	299.66	-63.43	-56.42	-13.00	-7.01	-50.43	Peak
5	586.78	-65.98	-64.66	-13.00	-1.32	-52.98	Peak
6	976.72	-61.97	-64.73	-13.00	2.76	-48.97	Peak
7	1638.00	-53.90	-39.11	-13.00	-14.79	-40.90	Peak
8	2457.00	-52.05	-41.61	-13.00	-10.44	-39.05	Peak



## 5 Pictures of Test Arrangements

Please refer to the attached file (Test Setup Photo).

## Appendix – Information of the Testing Laboratories

We, Bureau Veritas Consumer Products Services (H.K.) Ltd., Taoyuan Branch, were founded in 1988 to provide our best service in EMC, Radio, Telecom and Safety consultation. Our laboratories are FCC recognized accredited test firms and accredited according to ISO/IEC 17025.

If you have any comments, please feel free to contact us at the following:

**Lin Kou EMC/RF Lab**

Tel: 886-2-26052180

Fax: 886-2-26051924

**Hsin Chu EMC/RF/Telecom Lab**

Tel: 886-3-6668565

Fax: 886-3-6668323

**Hwa Ya EMC/RF/Safety**

Tel: 886-3-3183232

Fax: 886-3-3270892

**Email:** [service.adt@tw.bureauveritas.com](mailto:service.adt@tw.bureauveritas.com)

**Web Site:** [www.bureauveritas-adt.com](http://www.bureauveritas-adt.com)

The address and road map of all our labs can be found in our web site also.

--- END ---