



FCC Test Report

APPLICANT : Hewlett-Packard Company, Palm GBU
EQUIPMENT : Phone
BRAND NAME : HP
MODEL NUMBER : HSTNH-F30CN
FCC ID : B94HHF30CN
STANDARD : FCC Part 15 Subpart C §15.209
CLASSIFICATION : Part 15 Low Power Communication Device Transmitter (DXX)

The product was received on May 25, 2011 and completely tested on Jul. 05, 2011. We, SPORTON INTERNATIONAL INC., would like to declare that the tested sample has been evaluated in accordance with the procedures given in ANSI C63.4-2003 and shown the compliance with the applicable technical standards.

The test results in this report apply exclusively to the tested model / sample. Without written approval of SPORTON INTERNATIONAL INC., the test report shall not be reproduced except in full.

Reviewed by:

Jones Tsai / Manager



SPORTON INTERNATIONAL INC.

No. 52, Hwa Ya 1st Rd., Hwa Ya Technology Park, Kwei-Shan Hsiang, Tao Yuan Hsien, Taiwan, R.O.C.



TABLE OF CONTENTS

REVISION HISTORY..... 3

SUMMARY OF TEST RESULT 4

1. GENERAL DESCRIPTION 5

 1.1. Applicant..... 5

 1.2. Manufacturer 5

 1.3. Feature of Equipment Under Test..... 6

 1.4. Test Site 7

 1.5. Applied Standards 7

 1.6. Ancillary Equipment List..... 7

2. TEST CONFIGURATION OF EQUIPMENT UNDER TEST 8

 2.1. Test Mode 8

 2.2. Connection Diagram of Test System 9

3. TEST RESULT..... 10

 3.1. Test of AC Conducted Emission Measurement 10

 3.2. 99% Bandwidth Measurement 14

 3.3. Test of Radiated Emission Measurement 16

4. LIST OF MEASURING EQUIPMENT 21

5. UNCERTAINTY OF EVALUATION 23



SUMMARY OF TEST RESULT

Report Section	FCC Rule	IC Rule	Description	Limit	Result	Remark
3.1	15.207	Gen 7.2.2	AC Conducted Emission	15.207(a)	PASS	Under limit 5.1 dB at 1.67 MHz
3.2	-	Gen 4.4.1	99% Bandwidth	-	PASS	
3.3	15.209	RSS-210 Section 2.6	Radiated Emission	FCC Part 15.209(a) IC RSS-Gen, Section 7.2.4	PASS	Under limit 8.10 dB at 47.82 MHz



1. General Description

1.1. Applicant

Hewlett-Packard Company, Palm GBU
950 W Maude Avenue, Sunnyvale, CA 94085

1.2. Manufacturer

Hewlett-Packard Company, Palm GBU
950 W Maude Avenue, Sunnyvale, CA 94085

1.3. Feature of Equipment Under Test

Product Feature & Specification	
Equipment	Phone
Brand Name	HP
Model Number	HSTNH-F30CN
FCC ID	B94HHF30CN
Tx Frequency Range	GSM850 : 824 MHz ~ 849 MHz GSM1900 : 1850 MHz ~ 1910 MHz WCDMA Band II : 1850 MHz ~ 1910 MHz WCDMA Band V : 824 MHz ~ 849 MHz Bluetooth : 2400 MHz ~ 2483.5 MHz WLAN : 2400 MHz ~ 2483.5 MHz 5150 MHz ~ 5350 MHz 5470 MHz ~ 5725 MHz 5725 MHz ~ 5850 MHz Wireless charging: 3.1MHz, 6 MHz
Rx Frequency Range	GSM850 : 869 MHz ~ 894 MHz GSM1900 : 1930 MHz ~ 1990 MHz WCDMA Band II : 1930 MHz ~ 1990 MHz WCDMA Band V : 869 MHz ~ 894 MHz Bluetooth : 2400 MHz ~ 2483.5 MHz WLAN : 2400 MHz ~ 2483.5 MHz 5150 MHz ~ 5350 MHz 5470 MHz ~ 5725 MHz 5725 MHz ~ 5850 MHz Wireless charging: 118.5KHz, 3.1MHz, 6 MHz
Antenna Type	WWAN : Fixed Internal Antenna WLAN : PIFA Antenna Bluetooth : PIFA Antenna
HW Version	D1
SW Version	WebOS 2.3
Type of Modulation	GSM / GPRS : GMSK WCDMA : QPSK HSDPA : QPSK / 16QAM HSUPA : QPSK Bluetooth (1Mbps) : GFSK Bluetooth EDR (2Mbps) : $\pi/4$ -DQPSK Bluetooth EDR (3Mbps) : 8-DPSK 802.11b : DSSS (BPSK / QPSK / CCK) 802.11a/g/n : OFDM (BPSK / QPSK / 16QAM / 64QAM)
EUT Stage	Identical Prototype

Product Feature & Specification	
Equipment	Inductive Charging Dock
Model Number	HSTNH-T32C
P/N	180-10885-00
Tx Frequency Range	Wireless charging: 118.5KHz, 3.1MHz, 6 MHz

Remark: The above EUT's information was declared by manufacturer. Please refer to the specifications or user's manual for more detailed description.

1.4. Test Site

Test Site	SPORTON INTERNATIONAL INC.		
Test Site Location	No. 52, Hwa Ya 1 st Rd., Hwa Ya Technology Park, Kwei-Shan Hsiang, Tao Yuan Hsien, Taiwan, R.O.C. TEL: +886-3-327-3456 FAX: +886-3-328-4978		
Test Site No.	Sporton Site No.		
	CO05-HY	03CH07-HY	10CH02-HY

1.5. Applied Standards

According to the specifications of the manufacturer, the EUT must comply with the requirements of the following standards:

- FCC Part 15 Subpart C §15.209
- ANSI C63.4-2003
- IC RSS-Gen Issue 3
- IC RSS-210 Issue 8

Remark: All test items were verified and recorded according to the standards and without any deviation during the test.

1.6. Ancillary Equipment List

Item	Equipment	Trade Name	Model Name	FCC ID	Data Cable	Power Cord
1.	System Simulator	R&S	CMU 200	N/A	N/A	Unshielded, 1.8 m
2.	WLAN AP	D-Link	DIR-628	KA2DIR628A2	N/A	Unshielded, 1.8 m

2. Test Configuration of Equipment Under Test

2.1. Test Mode

The EUT has been associated with peripherals pursuant to ANSI C63.4-2003 and configuration operated in a manner tended to maximize its emission characteristics in a typical application.

Frequency range investigated: conducted emission (150 kHz to 30 MHz), radiation (9 kHz to 1000 MHz)

Test Items	Function Type
AC Conducted Emission	Mode 1: GSM850 Idle + WLAN Idle + Bluetooth On + Inductive Charger + USB Cable (Charging from Adapter 1) + Earphone + Battery 1 (Fig.1)
Radiated Emissions	Mode 1: EUT + Inductive Charger + USB Cable (Charging from Adapter 1) (Fig.2)

Note: KDB 680106 "Client Device Considerations" was considered and evaluation performed as applicable to this device. EUT is working in charging mode with the inductive charger. The inductive back cover (receiving hardware) is non-removable, is part of the phone.

2.2. Connection Diagram of Test System

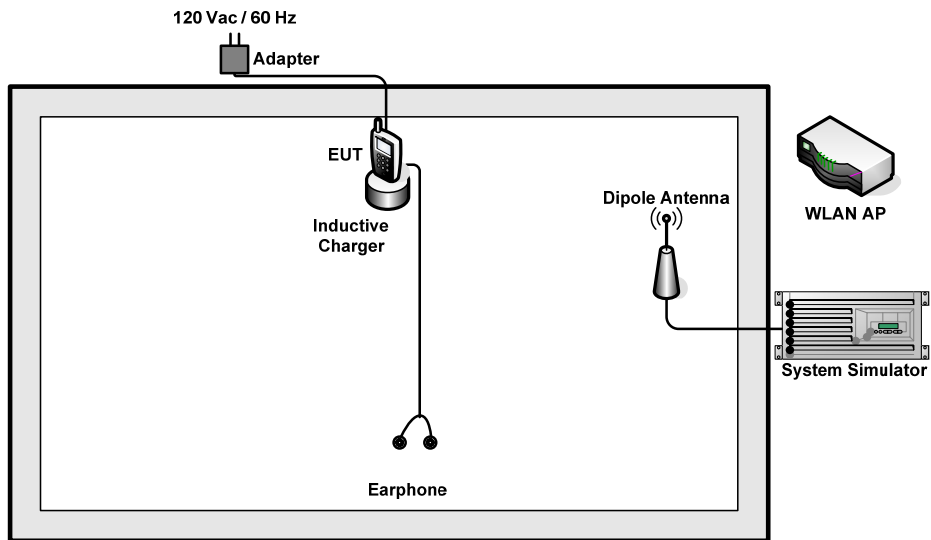

<Fig.1>

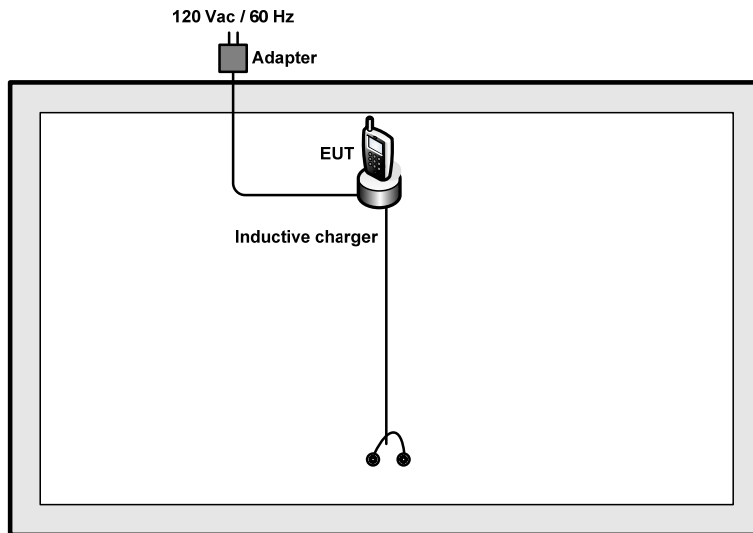

<Fig.2>

3. Test Result

3.1. Test of AC Conducted Emission Measurement

3.1.1. Limits of AC Conducted Emission

For equipment that is designed to be connected to the public utility (AC) power line, the radio frequency voltage that is conducted back onto the AC power line on any frequency or frequencies within the band 150 kHz to 30 MHz shall not exceed the limits in the following table.

Frequency of emission (MHz)	Conducted limit (dBuV)	
	Quasi-peak	Average
0.15-0.5	66 to 56*	56 to 46*
0.5-5	56	46
5-30	60	50

*Decreases with the logarithm of the frequency.

3.1.2. Measuring Instruments

See list of measuring instruments of this test report.

3.1.3. Test Procedure

1. The EUT was placed 0.4 meter from the conducting wall of the shielding room was kept at least 80 centimeters from any other grounded conducting surface.
2. Connect EUT to the power mains through a line impedance stabilization network (LISN).
3. All the support units are connecting to the other LISN.
4. The LISN provides 50 ohm coupling impedance for the measuring instrument.
5. The FCC states that a 50 ohm, 50 microhenry LISN should be used.
6. Both sides of AC line were checked for maximum conducted interference.
7. The frequency range from 150 kHz to 30 MHz was searched.
8. Set the test-receiver system to Peak Detect Function and specified bandwidth with Maximum Hold Mode.

3.1.4. Test Setup

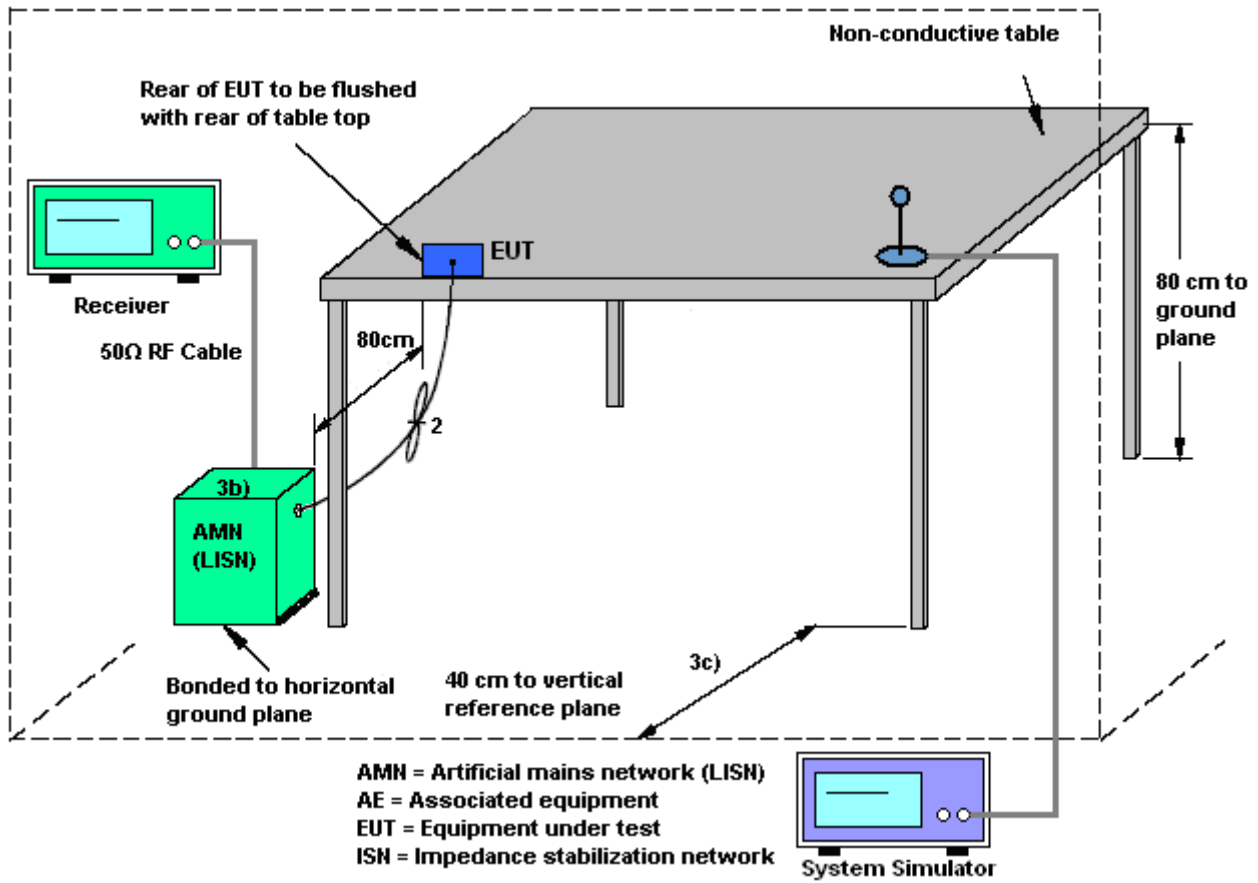

3.1.5. Test Result of AC Conducted Emission

Test Mode :	Mode 1	Temperature :	21~23°C
Test Engineer :	Novic Chiang	Relative Humidity :	41~43%
Test Voltage :	120Vac / 60Hz	Phase :	Line
Function Type :	GSM850 Idle + WLAN Idle + Bluetooth On + Inductive Charger + USB Cable (Charging from Adapter 1) + Earphone + Battery 1		
Remark :	All emissions not reported here are more than 10 dB below the prescribed limit.		

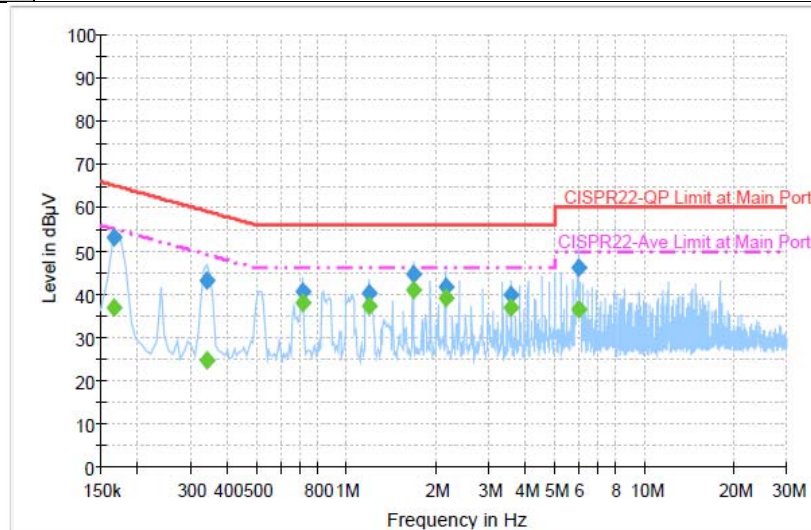

Final Result 1

Frequency (MHz)	QuasiPeak (dBµV)	Filter	Line	Corr. (dB)	Margin (dB)	Limit (dBµV)
0.166000	53.0	Off	L1	19.3	12.2	65.2
0.342000	43.2	Off	L1	19.3	16.0	59.2
0.718000	40.6	Off	L1	19.4	15.4	56.0
1.190000	40.3	Off	L1	19.4	15.7	56.0
1.670000	44.6	Off	L1	19.4	11.4	56.0
2.150000	41.8	Off	L1	19.4	14.2	56.0
3.582000	39.8	Off	L1	19.5	16.2	56.0
5.998000	46.0	Off	L1	19.5	14.0	60.0

Final Result 2

Frequency (MHz)	Average (dBµV)	Filter	Line	Corr. (dB)	Margin (dB)	Limit (dBµV)
0.166000	36.8	Off	L1	19.3	18.4	55.2
0.342000	24.6	Off	L1	19.3	24.6	49.2
0.718000	37.8	Off	L1	19.4	8.2	46.0
1.190000	37.3	Off	L1	19.4	8.7	46.0
1.670000	40.9	Off	L1	19.4	5.1	46.0
2.150000	39.0	Off	L1	19.4	7.0	46.0
3.582000	36.8	Off	L1	19.5	9.2	46.0
5.998000	36.4	Off	L1	19.5	13.6	50.0

Test Mode :	Mode 1	Temperature :	21~23°C
Test Engineer :	Novic Chiang	Relative Humidity :	41~43%
Test Voltage :	120Vac / 60Hz	Phase :	Neutral
Function Type :	GSM850 Idle + WLAN Idle + Bluetooth On + Inductive Charger + USB Cable (Charging from Adapter 1) + Earphone + Battery 1		
Remark :	All emissions not reported here are more than 10 dB below the prescribed limit.		

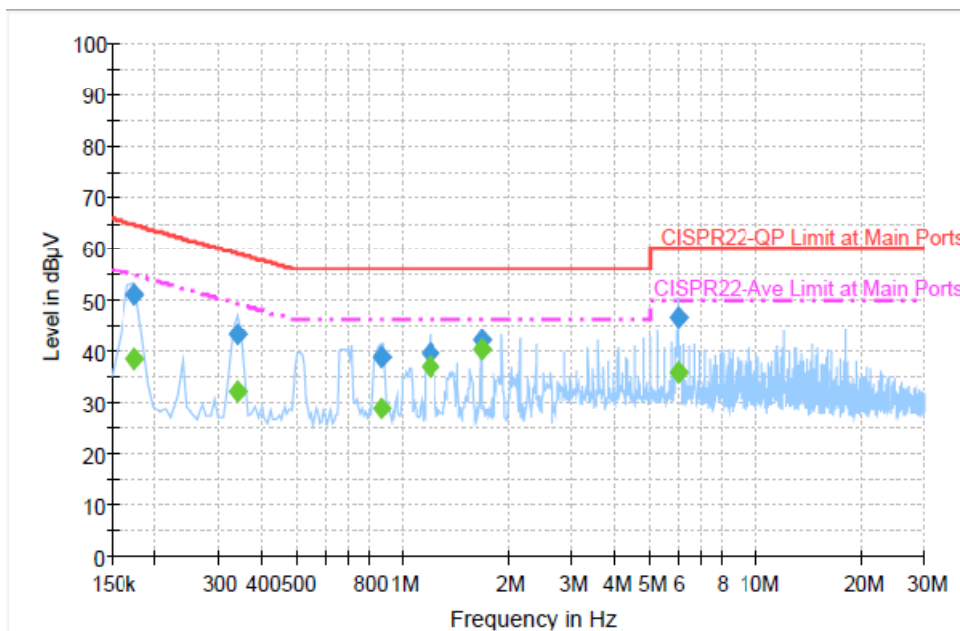

Final Result 1

Frequency (MHz)	QuasiPeak (dBµV)	Filter	Line	Corr. (dB)	Margin (dB)	Limit (dBµV)
0.174000	50.8	Off	N	19.3	14.0	64.8
0.342000	43.1	Off	N	19.3	16.1	59.2
0.870000	38.8	Off	N	19.4	17.2	56.0
1.190000	39.6	Off	N	19.5	16.4	56.0
1.670000	42.0	Off	N	19.5	14.0	56.0
5.998000	46.6	Off	N	19.5	13.4	60.0

Final Result 2

Frequency (MHz)	Average (dBµV)	Filter	Line	Corr. (dB)	Margin (dB)	Limit (dBµV)
0.174000	38.5	Off	N	19.3	16.3	54.8
0.342000	32.0	Off	N	19.3	17.2	49.2
0.870000	28.6	Off	N	19.4	17.4	46.0
1.190000	36.9	Off	N	19.5	9.1	46.0
1.670000	40.3	Off	N	19.5	5.7	46.0
5.998000	35.7	Off	N	19.5	14.3	50.0

3.2. 99% Bandwidth Measurement

3.2.1 Measuring Instruments

See list of measuring instruments of this test report.

3.2.2 Test Procedures

1. The testing follows FCC KDB Publication No. 558074 (Measurement Guidelines of DXX).
2. The RF output of EUT was connected to the spectrum analyzer by a low loss cable.
3. Make the measurement with the spectrum analyzer's resolution bandwidth (RBW) = 100 kHz.
In order to make an accurate measurement, set the span greater than RBW.

3.2.3 Test Setup

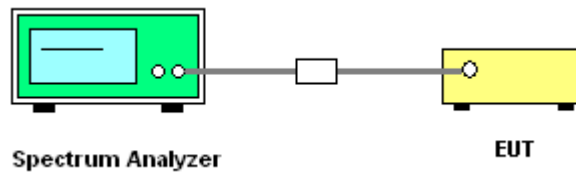

3.2.4 Test Result of 99% Bandwidth

Test Engineer :	Pinkston Tu	Temperature :	23~25°C
		Relative Humidity :	40~42%

Frequency (MHz)	99% Occupied Bandwidth (MHz)	Pass/Fail
3.1	1.183	Pass
6	1.308	Pass

3.1M 99% Occupied Bandwidth Plot

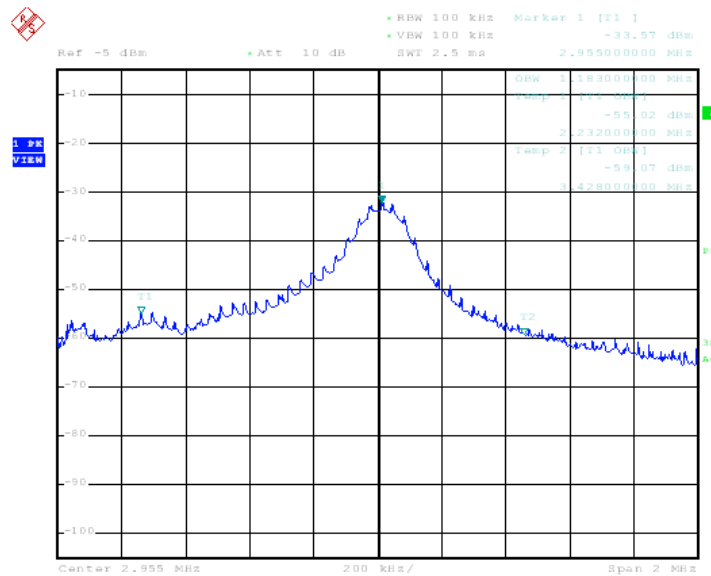

6M 99% Occupied Bandwidth Plot

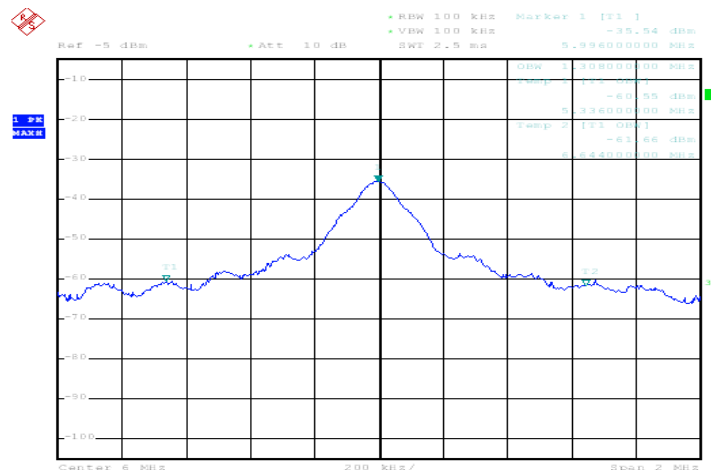

3.3. Test of Radiated Emission Measurement

3.3.1. Limit of Radiated Emission

The emissions from an intentional radiator shall not exceed the field strength levels specified in the following table:

Frequency (MHz)	Field Strength (microvolts/meter)	Measurement Distance (meters)
0.009 – 0.490	2400/F(kHz)	300
0.490 – 1.705	24000/F(kHz)	30
1.705 – 30.0	30	30
30 – 88	100	3
88 – 216	150	3
216 - 960	200	3
Above 960	500	3

3.3.2. Measuring Instruments

See list of measuring instruments of this test report.

3.3.3. Test Procedures

Follow the guidelines in ANSI C63.4-2003 with respect to maximizing the emission by rotating the EUT, measuring the emission for three EUT orthogonal planes, and adjusting the measurement antenna height and polarization. A pre-amp and a high pass filter are used for this test in order to get the good signal level.

3.3.4. Test Setup of Radiated Emission

For radiated emissions below 30MHz

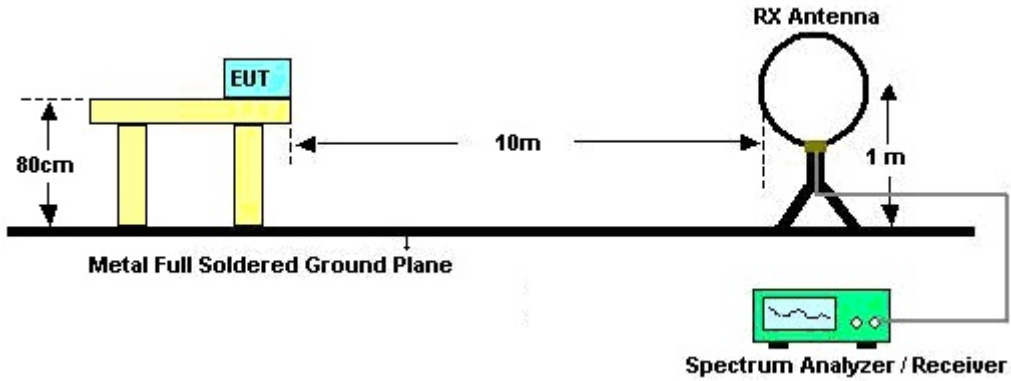

For radiated emissions above 30MHz

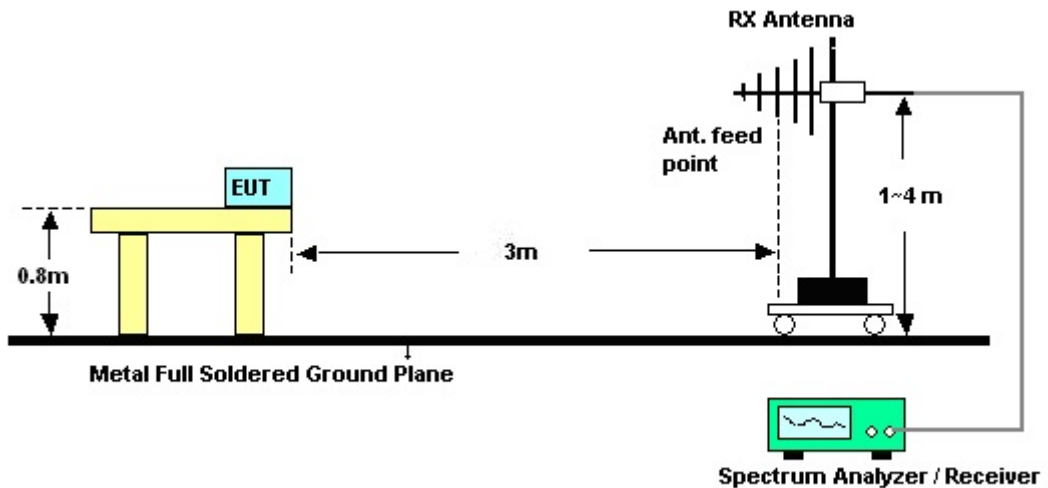



3.3.5. Test Result of Radiated Emission (9k Hz ~ 30M Hz)

Frequency	Measurement Distance	Field Strength	Antenna Factor	Distance Factor	Limit Distance	Field Strength at Limit Distance	Limit
(MHz)	(m)	(dBuV/m)	(dB/m)	(dB/decade)	(m)	(dBuV/m)	(dBuV/m)
3.1	10	29.52	19.7	40	30	10.44	29.54
6	10	29.93	19.7	40	30	10.85	29.54

- Note:**
- (3.1 MHz, 6MHz) is the fundamental frequency, and no other emissions observed up to 30MHz.
 - In accordance with 15.31 (f)(2): For each frequency at which a measurement is made at only one distance, the square of an inverse linear distance extrapolation factor (40 dB/decade) is applied.
Distance extrapolation factor = $40 \log(\text{specific distance} / \text{test distance})$ (dB);
Limit line = specific limits (dBuV) + distance extrapolation factor.
 - The field strength measured is direct conversion of all parameters (antenna factor and distance extrapolation factor) and loaded into the spectrum.

3.3.6. Test Result of Radiated Emission (30M Hz ~ 1000M Hz)

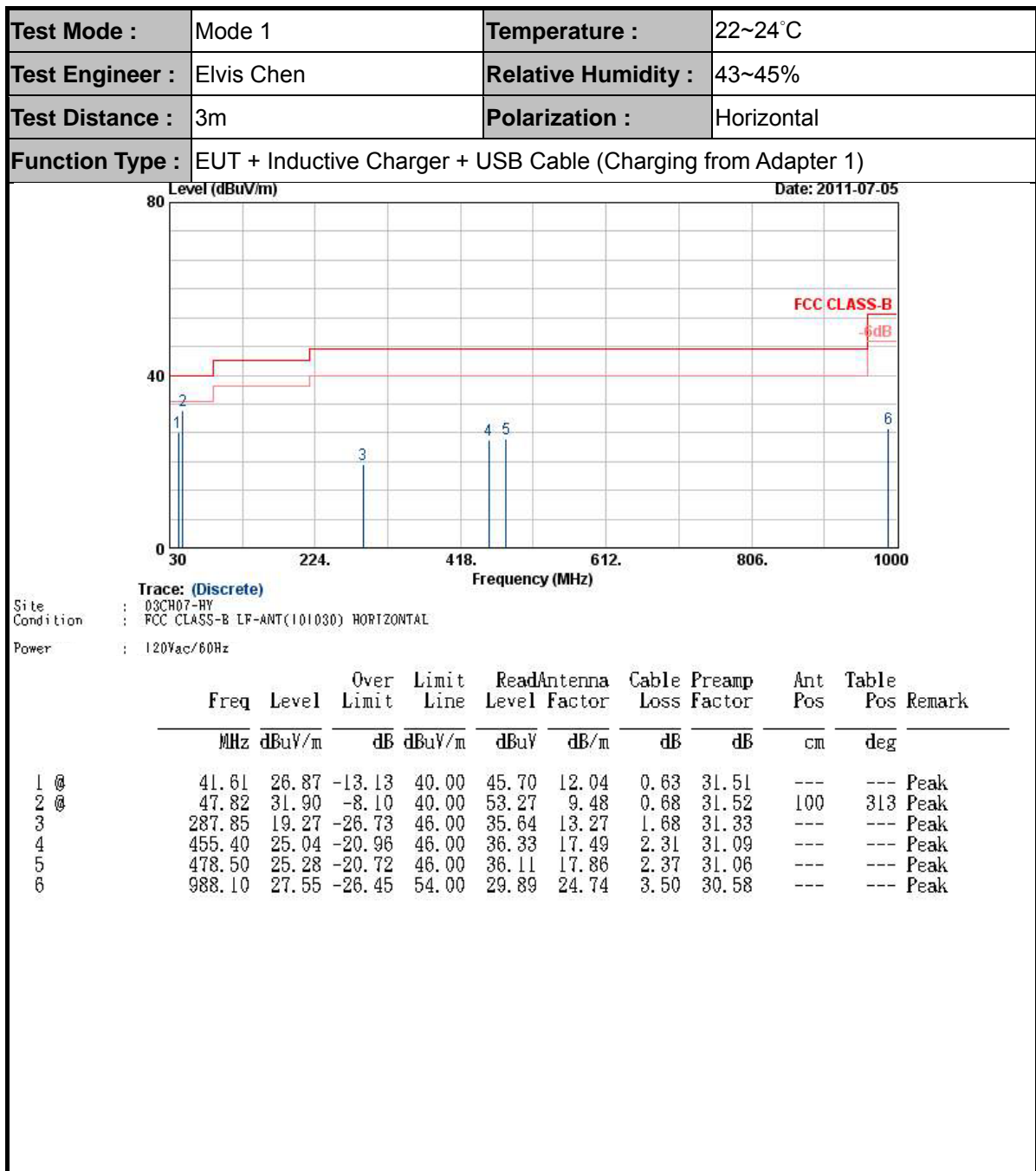



Test Mode :	Mode 1	Temperature :	22~24°C
Test Engineer :	Elvis Chen	Relative Humidity :	43~45%
Test Distance :	3m	Polarization :	Vertical
Function Type :	EUT + Inductive Charger + USB Cable (Charging from Adapter 1)		

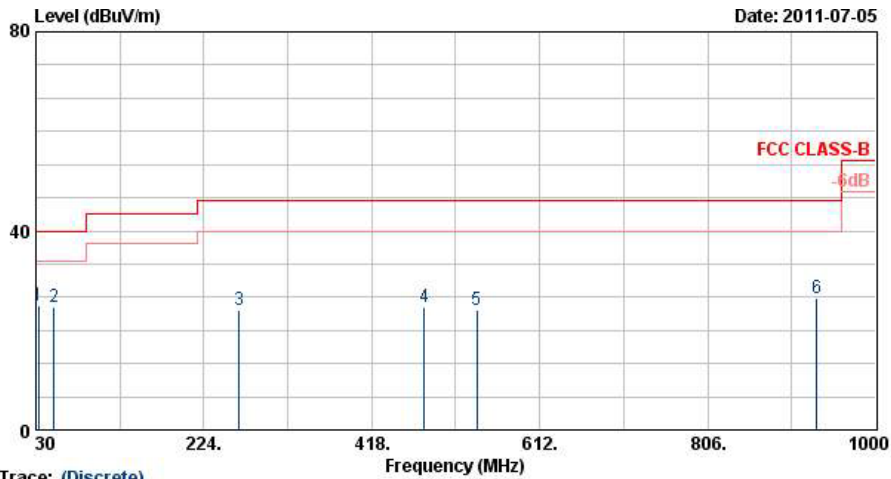

Trace: (Discrete)
 Site : 03CH07-HY
 Condition : FCC CLASS-B LF-ANT(101030) VERTICAL
 Power : 120Vac/60Hz

	Freq	Level	Over	Limit	ReadAntenna	Cable	Preamp	Ant	Table	Remark
	MHz	dBuV/m	Limit	Line	Level	Loss	Factor	Pos	Pos	
			dB	dBuV/m	dBuV	dB	dB	cm	deg	
1 @	32.97	24.95	-15.05	40.00	40.05	15.80	0.56	31.47	114	208 Peak
2	51.33	24.62	-15.38	40.00	47.44	8.02	0.71	31.54	---	---
3	265.17	24.16	-21.84	46.00	41.04	12.90	1.62	31.40	---	---
4	478.50	24.82	-21.18	46.00	35.65	17.86	2.37	31.06	---	---
5	539.40	24.02	-21.98	46.00	33.66	18.83	2.53	31.00	---	---
6	932.10	26.62	-19.38	46.00	29.78	24.03	3.42	30.62	---	---

4. List of Measuring Equipment

Instrument	Manufacturer	Model No.	Serial No.	Characteristics	Calibration Date	Due Date	Remark
EMI Test Receive	R&S	ESCS 30	100356	9KHz – 2.75GHz	Aug. 16, 2010	Aug. 15, 2011	Conduction (CO05-HY)
Two-LISN	R&S	ENV216	11-100081	9KHz – 30MHz	Dec. 03, 2010	Dec. 02, 2011	Conduction (CO05-HY)
Two-LISN	R&S	ENV216	11-100080	9KHz – 30MHz	Dec. 01, 2010	Nov. 30, 2011	Conduction (CO05-HY)
AC Power Source	APC	APC-1000W	N/A	N/A	N/A	N/A	Conduction (CO05-HY)
ISN	Teseq GmbH	ISN T400A	25696	N/A	Jun. 16, 2011	Jun. 15, 2012	Conduction (CO05-HY)
ISN	Teseq GmbH	ISN T800	27134	N/A	Jun. 16, 2011	Jun. 15, 2012	Conduction (CO05-HY)
DC- LISN	R&S	ESH3-26	1000485	0.1MHz~200MHz	Jun. 08, 2011	Jun. 07, 2012	Conduction (CO05-HY)
DC- LISN	R&S	ESH3-26	1000484	0.1MHz~200MHz	Jun. 08, 2011	Jun. 07, 2012	Conduction (CO05-HY)
System Simulator	R&S	CMU200	117995	N/A	Aug. 11, 2010	Aug.10, 2011	Conduction (CO05-HY)
System Simulator	R&S	CMU200	117995	N/A	Aug. 11, 2010	Aug.10, 2011	Conducted (TH02-HY)
Spectrum Analyzer	R&S	FSP40	100055	9kHz~40GHz	Jun. 13, 2011	Jun. 12, 2012	Conducted (TH02-HY)
Power Meter	Anritsu	ML2495A	0932001	N/A	Sep. 13, 2010	Sep. 12, 2011	Conducted (TH02-HY)
Power Sensor	Anritsu	MA2411B	0846202	N/A	Sep. 14, 2010	Sep. 13, 2011	Conducted (TH02-HY)
Power Meter	Agilent	E4416A	GB41292344	N/A	Feb. 18, 2011	Feb. 17, 2012	Conducted (TH02-HY)
Power Sensor	Agilent	E9327A	US40441548	N/A	Feb. 18, 2011	Feb. 17, 2012	Conducted (TH02-HY)
Thermal Chamber	Ten Billion	TTH-D35P	TBN-930701	N/A	Jul. 30, 2010	Jul. 29, 2011	Conducted (TH02-HY)



Instrument	Manufacturer	Model No.	Serial No.	Characteristics	Calibration Date	Due Date	Remark
Amplifier	AGILENT	8447D	2944A10827	100KHz – 1.3GHz	May 20, 2011	May 19, 2012	Radiation (10CH02-HY)
Amplifier	AGILENT	8447D	2944A10828	100KHz – 1.3GHz	May 16, 2011	May 19, 2012	Radiation (10CH02-HY)
Receiver	R&S	ESI	838496/008	20Hz - 7GHz	Apr. 24, 2011	Apr. 23, 2012	Radiation (10CH02-HY)
Spectrum Analyzer	R&S	FSP7	100645	9KHz – 7GHz	Jun. 01, 2011	Jun. 01, 2012	Radiation (10CH02-HY)
Biconical Antenna	Schwarzbeck	VHBB 9124	287	30MHz~200MHz	Dec. 20, 2010	Dec. 19, 2011	Radiation (10CH02-HY)
Log Antenna	Schwarzbeck	VUSLP 9111	207	200MHz~1GHz	Dec. 20, 2010	Dec. 19, 2011	Radiation (10CH02-HY)
Amplifier	EMCI	EMC330	980007	1 -8GHz	May 09, 2011	May 08, 2012	Radiation (10CH02-HY)
Horn antenna	EMCO	3115	6903	1~18GHz	May 04, 2011	May 03, 2012	Radiation (10CH02-HY)
Receiver	R&S	ESI	838496/008	20Hz - 7GHz	Apr. 24, 2011	Apr. 23, 2012	Radiation (10CH02-HY)
Bilog Antenna	SCHAFFNER	CBL6111C	2726	30MHz ~ 1GHz	Oct. 31, 2010	Oct. 30, 2011	Radiation (03CH07-HY)
Spectrum Analyzer	R&S	FSP	101067	9KHz ~ 30GHz	Dec. 03, 2010	Dec. 02, 2011	Radiation (03CH07-HY)
Double Ridge Horn Antenna	ESCO	3117	00075962	1GHz ~ 18GHz	Aug. 19, 2010	Aug. 18, 2011	Radiation (03CH07-HY)
SHF-EHF Horn Antenna	SCHWARZBECK	BBHA 9170	BBHA9170251	15GHz- 40GHz	Oct. 18, 2010	Oct. 17, 2011	Radiation (03CH07-HY)
Pre Amplifier	Agilent	8449B	3008A02362	1GHz~ 26.5GHz	Dec. 06, 2010	Dec. 05, 2011	Radiation (03CH07-HY)
Pre Amplifier	COM-POWER	PA-103A	161241	10-1000MHz.32 dB.GAIN	Mar. 29, 2011	Mar. 28, 2012	Radiation (03CH07-HY)
Loop Antenna	R&S	HFH2-Z2	860004/001	9 kHz~30 MHz	Jul. 29, 2010	Jul. 28, 2011	Radiation (03CH07-HY)

5. Uncertainty of Evaluation

Uncertainty of Conducted Emission Measurement (150 kHz ~ 30 MHz)

Contribution	Uncertainty of X_i		$u(X_i)$
	dB	Probability Distribution	
Receiver Reading	0.10	Normal (k=2)	0.05
Cable Loss	0.10	Normal (k=2)	0.05
AMN Insertion Loss	2.50	Rectangular	0.63
Receiver Specification	1.50	Rectangular	0.43
Site Imperfection	1.39	Rectangular	0.80
Mismatch	+0.34 / -0.35	U-Shape	0.24
Combined Standard Uncertainty $U_c(y)$	1.13		
Measuring Uncertainty for a Level of Confidence of 95% ($U = 2U_c(y)$)	2.26		

Uncertainty of Radiated Emission Measurement (30 MHz ~ 1000 MHz)

Contribution	Uncertainty of X_i		$u(X_i)$
	dB	Probability Distribution	
Receiver Reading	0.41	Normal (k=2)	0.21
Antenna Factor Calibration	0.83	Normal (k=2)	0.42
Cable Loss Calibration	0.25	Normal (k=2)	0.13
Pre-Amplifier Gain Calibration	0.27	Normal (k=2)	0.14
RCV/SPA Specification	2.50	Rectangular	0.72
Antenna Factor Interpolation for Frequency	1.00	Rectangular	0.29
Site Imperfection	1.43	Rectangular	0.83
Mismatch	+0.39 / -0.41	U-Shape	0.28
Combined Standard Uncertainty $U_c(y)$	1.27		
Measuring Uncertainty for a Level of Confidence of 95% ($U = 2U_c(y)$)	2.54		