



Prüfbericht-Nr.: <i>Test report no.:</i>	CN24U0Y7 001	Auftrags-Nr.: <i>Order no.:</i>	48248918	Seite 1 von 25 Page 1 of 25
Kunden-Referenz-Nr.: <i>Client reference no.:</i>	N/A	Auftragsdatum: <i>Order date:</i>	2024-06-17	
Auftraggeber: <i>Client:</i>	HP Inc. 3390 East Harmony Road, Fort Collins, CO 80528, USA			
Prüfgegenstand: <i>Test item:</i>	Wireless Mouse			
Bezeichnung / Typ-Nr.: <i>Identification / Type no.:</i>	HXMS235			
Auftrags-Inhalt: <i>Order content:</i>	FCC Part 15C Test report (BLE)			
Prüfgrundlage: <i>Test specification:</i>	FCC 47CFR Part 15: Subpart C Section 15.247			
Wareneingangsdatum: <i>Date of sample receipt:</i>	2024-06-03			
Prüfmuster-Nr.: <i>Test sample no.:</i>	A003733972-025 A003733972-035			
Prüfzeitraum: <i>Testing period:</i>	2024-06-20 - 2024-07-08			
Ort der Prüfung: <i>Place of testing:</i>	EMC/RF Taipei Testing Site			
Prüflaboratorium: <i>Testing laboratory:</i>	Taipei Testing Laboratories			
Prüfergebnis*: <i>Test result*:</i>	Pass			
zusammengestellt von: <i>compiled by:</i>	 Ryan Chen	genehmigt von: <i>authorized by:</i>	 Brenda Chen	
Datum: <i>Date:</i>	2024-07-11	Ausstellungsdatum: <i>Issue date:</i>	2024-07-11	
Stellung / Position:	Senior Project Manager	Stellung / Position:	Senior Project Manager	
Sonstiges / Other:				
Zustand des Prüfgegenstandes bei Anlieferung: <i>Condition of the test item at delivery:</i>		Prüfmuster vollständig und unbeschädigt <i>Test item complete and undamaged</i>		
* Legende:	1 = sehr gut P(ass) = entspricht o.g. Prüfgrundlage(n)	2 = gut F(ail) = entspricht nicht o.g. Prüfgrundlage(n)	3 = befriedigend N/A = nicht anwendbar	4 = ausreichend N/T = nicht getestet
* Legend:	1 = very good P(ass) = passed a.m. test specification(s)	2 = good F(ail) = failed a.m. test specification(s)	3 = satisfactory N/A = not applicable	4 = sufficient N/T = not tested
Dieser Prüfbericht bezieht sich nur auf das o.g. Prüfmuster und darf ohne Genehmigung der Prüfstelle nicht auszugsweise vervielfältigt werden. Dieser Bericht berechtigt nicht zur Verwendung eines Prüfzeichens. <i>This test report only relates to the a. m. test sample. Without permission of the test center this test report is not permitted to be duplicated in extracts. This test report does not entitle to carry any test mark.</i>				

Prüfbericht-Nr.:
Test report no.:

CN24U0Y7 001

Seite 2 von 25
Page 2 of 25

Anmerkungen
Remarks

1	<p>Alle eingesetzten Prüfmittel waren zum angegebenen Prüfzeitraum gemäß eines festgelegten Kalibrierungsprogramms unseres Prüfhauses kalibriert. Sie entsprechen den in den Prüfprogrammen hinterlegten Anforderungen. Die Rückverfolgbarkeit der eingesetzten Prüfmittel ist durch die Einhaltung der Regelungen unseres Managementsystems gegeben. Detaillierte Informationen bezüglich Prüfkonditionen, Prüfequipment und Messunsicherheiten sind im Prüflabor vorhanden und können auf Wunsch bereitgestellt werden.</p> <p><i>The equipment used during the specified testing period was calibrated according to our test laboratory calibration program. The equipment fulfils the requirements included in the relevant standards. The traceability of the test equipment used is ensured by compliance with the regulations of our management system. Detailed information regarding test conditions, equipment and measurement uncertainty is available in the test laboratory and could be provided on request.</i></p>
2	<p>Wie vertraglich vereinbart, wurde dieses Dokument nur digital unterzeichnet. Der TÜV Rheinland hat nicht überprüft, welche rechtlichen oder sonstigen diesbezüglichen Anforderungen für dieses Dokument gelten. Diese Überprüfung liegt in der Verantwortung des Benutzers dieses Dokuments. Auf Verlangen des Kunden kann der TÜV Rheinland die Gültigkeit der digitalen Signatur durch ein gesondertes Dokument bestätigen. Diese Anfrage ist an unseren Vertrieb zu richten. Eine Umweltgebühr für einen solchen zusätzlichen Service wird erhoben. Informationen zur Verifizierung der Authentizität unserer Dokumente erhalten Sie auf folgender Webseite: go.tuv.com/digital-signature</p> <p><i>As contractually agreed, this document has been signed digitally only. TUV Rheinland has not verified and unable to verify which legal or other pertaining requirements are applicable for this document. Such verification is within the responsibility of the user of this document. Upon request by its client, TUV Rheinland can confirm the validity of the digital signature by a separate document. Such request shall be addressed to our Sales department. An environmental fee for such additional service will be charged. For information on verifying the authenticity of our documents, please visit the following website: go.tuv.com/digital-signature</i></p>
3	<p>Prüfklausel mit der Note * wurden an qualifizierte Unterauftragnehmer vergeben und sind unter der jeweiligen Prüfklausel des Berichts beschrieben. Abweichungen von Prüfspezifikation(en) oder Kundenanforderungen sind in der jeweiligen Prüfklausel im Bericht aufgeführt.</p> <p><i>Test clauses with remark of * are subcontracted to qualified subcontractors and described under the respective test clause in the report. Deviations of testing specification(s) or customer requirements are listed in specific test clause in the report.</i></p>
4	<p>Die Entscheidungsregel für Konformitätserklärungen basierend auf numerischen Messergebnissen in diesem Prüfbericht basiert auf der "Null-Grenzwert-Regel" und der "Einfachen Akzeptanz" gemäß ILAC G8:2019 und IEC Guide 115:2021, es sei denn, in der auf Seite 1 dieses Berichts genannten angewandten Norm ist etwas anderes festgelegt oder vom Kunden gewünscht. Dies bedeutet, dass die Messunsicherheit nicht berücksichtigt wird und daher auch nicht im Prüfbericht angegeben wird. Zu weiteren Informationen bezüglich des Risikos durch diese Entscheidungsregel siehe ILAC G8:2019.</p> <p><i>The decision rule for statements of conformity, based on numerical measurement results, in this test report is based on the "Zero Guard Band Rule" and "Simple Acceptance" in accordance with ILAC G8:2019 and IEC Guide 115:2021, unless otherwise specified in the applied standard mentioned on Page 1 of this report or requested by the customer. This means that measurement uncertainty is not taken in account and hence also not declared in the test report. For additional information to the resulting risk based of this decision rule please refer to ILAC G8:2019.</i></p>

Prüfbericht-Nr.: CN24U0Y7 001
Test report no.:Seite 3 von 25
Page 3 of 25

TEST SUMMARY

Report Section	FCC Clause	Test Item	Result
5.1.1	15.247(b) & 15.203	Antenna Requirement	Pass
5.1.2	15.247(b)(3)	Peak Output Power	Pass
5.1.3	15.247(a)(2)	6 dB Bandwidth	Pass
5.1.3	2.1049	99% Occupied Bandwidth	Pass
5.1.4	15.247(e)	Power Spectral Density	Pass
5.1.5	15.247(d)	Conducted Spurious Emissions and Band Edges	Pass
5.1.6	15.247(d) & 15.205 & 15.209	Radiated Spurious Emissions and Band Edges	Pass
-	15.207	Mains Conducted Emission	N/A

Note: Determining compliance based on the results of the compliance measurement, not taking into account measurement instrumentation uncertainty.

Prüfbericht-Nr.: CN24U0Y7 001
Test report no.:

 Seite 4 von 25
 Page 4 of 25

Contents

HISTORY OF THIS TEST REPORT	6
1. GENERAL REMARKS	7
1.1 COMPLEMENTARY MATERIALS.....	7
1.2 DECISION RULE OF CONFORMITY	7
2. TEST SITES	8
2.1 TEST LABORATORY	8
2.2 TEST FACILITY.....	8
2.3 TRACEABILITY	9
2.4 CALIBRATION	9
2.5 MEASUREMENT UNCERTAINTY	9
3. GENERAL PRODUCT INFORMATION.....	10
3.1 PRODUCT FUNCTION AND INTENDED USE	10
3.2 SYSTEM DETAILS AND RATINGS.....	10
3.3 NOISE GENERATING AND NOISE SUPPRESSING PARTS	11
3.4 SUBMITTED DOCUMENTS.....	11
4. TEST SET-UP AND OPERATION MODES	12
4.1 PRINCIPLE OF CONFIGURATION SELECTION	12
4.2 CARRIER FREQUENCY AND CHANNEL.....	12
4.3 TEST OPERATION AND TEST SOFTWARE.....	13
4.4 SPECIAL ACCESSORIES AND AUXILIARY EQUIPMENT	14
4.5 TEST SETUP DIAGRAM	14
5. TEST RESULTS	15
5.1 TRANSMITTER REQUIREMENT & TEST SUITES	15
5.1.1 <i>Antenna Requirement</i>	<i>15</i>
5.1.2 <i>Peak Output Power</i>	<i>16</i>
5.1.3 <i>6 dB Bandwidth and 99% Occupied Bandwidth.....</i>	<i>18</i>
5.1.4 <i>Power Spectral Density.....</i>	<i>19</i>
5.1.5 <i>Conducted Spurious Emissions and Frequency Band Edges Measured in 100kHz Bandwidth</i>	<i>20</i>
5.1.6 <i>Radiated Spurious Emissions and Band Edges</i>	<i>21</i>

Prüfbericht-Nr.: **CN24U0Y7 001**
Test report no.:

Seite 5 von 25
Page 5 of 25

APPENDIX A - TEST RESULT OF CONDUCTED

APPENDIX B - TEST RESULT OF RADIATED EMISSIONS

APPENDIX SP - PHOTOGRAPHS OF TEST SETUP

APPENDIX EP - PHOTOGRAPHS OF EUT

Prüfbericht-Nr.: **CN24U0Y7 001**
Test report no.:

Seite 6 von 25
Page 6 of 25

HISTORY OF THIS TEST REPORT

Revision	Description	Date Issued
R01	Original Release	2024-07-11

Prüfbericht-Nr.: **CN24U0Y7 001**
Test report no.:Seite 7 von 25
Page 7 of 25

1. General Remarks

1.1 Complementary Materials

All attachments are integral parts of this test report. This applies especially to the following appendix:

Appendix A - Test Result of Conducted

Appendix B - Test Result of Radiated Emissions

Appendix SP - Photographs of Test Setup

Appendix EP - Photographs of EUT

Applied Standard and Test Levels

Radio
FCC 47CFR Part 15: Subpart C Section 15.247
FCC 47CFR Part 2: Subpart J Section 2.1049
ANSI C63.10:2013
KDB 558074 D01 15.247 Meas Guidance v05r02

1.2 Decision Rule of Conformity

The decision rule of conformity of this test report is following the requirements of the requested standard in the quotation, and agreed among testing laboratory and manufacturer (applicant) to exclude the consideration of Measurement Uncertainty, unless it is required by the specific standard.

Prüfbericht-Nr.: **CN24U0Y7 001**
Test report no.:

Seite 8 von 25
Page 8 of 25

2. Test Sites

2.1 Test Laboratory

Taipei Testing Laboratories

11F. No.758, Sec. 4, Bade Rd., Songshan Dist.
Taipei City 105
Taiwan (R.O.C.)

2.2 Test Facility

Taipei Testing Laboratories

No.458-18, Sec. 2, Fenliao Rd., Linkou Dist.,
New Taipei City 244
Taiwan (R.O.C.)
FCC Registration No.: 180491
ISED Registration No.: 25563

Prüfbericht-Nr.: CN24U0Y7 001
Test report no.:Seite 9 von 25
Page 9 of 25

2.3 Traceability

All measurement equipment calibrations are traceable to NML(Taiwan)/NIST(USA) or where calibration is performed outside Taiwan, to equivalent nationally recognized standards organizations.

2.4 Calibration

Equipment requiring calibration is calibrated periodically in a suitably accredited Calibration Lab. Additionally all equipment is verified for proper performance on a regular basis using in house standards or comparisons.

2.5 Measurement Uncertainty

All measurement uncertainty values are shown with a coverage factor of $k=2$ to indicate a 95% level of confidence.

Emission Measurement Uncertainty

Parameter	Uncertainty
Radiated Emission (9 kHz ~ 30 MHz)	± 1.15 dB
Radiated Emission (30 MHz ~ 200 MHz)	± 1.30 dB
Radiated Emission (200 MHz ~ 1 GHz)	± 1.30 dB
Radiated Emission (1 GHz ~ 18 GHz)	± 1.54 dB
Radiated Emission (18 GHz ~ 40 GHz)	± 2.52 dB
Mains Conducted Emission	± 1.65 dB

Prüfbericht-Nr.: CN24U0Y7 001
Test report no.:Seite 10 von 25
Page 10 of 25

3. General Product Information

3.1 Product Function and Intended Use

The EUT is a Wireless Mouse. It contains a Bluetooth compatible module enabling the user to communicate data through a Wireless interface.

For details refer to the User Guide, Data Sheet and Circuit Diagram.

3.2 System Details and Ratings

Basic Information of EUT

Item	EUT information
Kind of Equipment/Test Item	Wireless Mouse
Type Identification	HXMS235
FCC ID	B94-HXMS235

Technical Specification of EUT

Item	EUT information
Operating Frequency	2402 MHz ~ 2480 MHz
Channel Number	40
Data Rate	1Mbps, 2Mbps
Operation Voltage	1.5 Vdc
Modulation	GFSK
Maximum Output Power (mW)	2.5
Antenna Information	Refer to 5.1.1
Accessory Device	Refer to 4.4

Prüfbericht-Nr.: **CN24U0Y7 001**
Test report no.:

Seite 11 von 25
Page 11 of 25

3.3 Noise Generating and Noise Suppressing Parts

Refer to the Circuit Diagram.

3.4 Submitted Documents

- Circuit Diagram
- Instruction Manual
- Rating Label
- Technical Description

Prüfbericht-Nr.: CN24U0Y7 001
Test report no.:

 Seite 12 von 25
 Page 12 of 25

4. Test Set-up and Operation Modes

4.1 Principle of Configuration Selection

The test modes were adapted accordingly in reference to the instructions for use.

During testing, Channel and Power Controlling Software provided by the customer was used to control the operating channel as well as the output power level. The RF output power selection is for the setting of RF output expected by the customer and is going to be fixed on the firmware of the final end product.

Table for Parameters of Test Software Setting

Frequency (MHz)	Power Setting
2402	4
2440	4
2480	4

4.2 Carrier Frequency and Channel

Channel	Freq. (MHz)	Channel	Freq. (MHz)	Channel	Freq. (MHz)	Channel	Freq. (MHz)
0	2402	10	2422	20	2442	30	2462
1	2404	11	2424	21	2444	31	2464
2	2406	12	2426	22	2446	32	2466
3	2408	13	2428	23	2448	33	2468
4	2410	14	2430	24	2450	34	2470
5	2412	15	2432	25	2452	35	2472
6	2414	16	2434	26	2454	36	2474
7	2416	17	2436	27	2456	37	2476
8	2418	18	2438	28	2458	38	2478
9	2420	19	2440	29	2460	39	2480

Prüfbericht-Nr.: CN24U0Y7 001
Test report no.:

 Seite 13 von 25
 Page 13 of 25

4.3 Test Operation and Test Software

Setup for testing: Test samples are provided with UART interface which makes it possible to control them through a test software installed on a notebook computer.

This software was running on the laptop computer connected to the EUT. It was used to enable the operation modes listed as below.

Test Software	PXI_LINK_Tool_v1.3.5
---------------	----------------------

The samples were used as follows:

A003733972-025

A003733972-035

Full test was applied on all test modes, but only worst case was shown.

EUT Configure Mode	Applicable To				Description
	Antenna Port Conducted Measurement	Radiated Spurious Emissions above 1 GHz	Radiated Spurious Emissions below 1 GHz	Mains Conducted Emission	
-	√	√	√	-	-

Note:

1. The EUT had been pre-tested on the positioned of each 3 axis. The worst case was found when position on **Z-plane**.
2. "-" means no effect.

Antenna Port Conducted Measurement

- Pre-Scan full test was applied on all test modes, but only worst case was shown.
- Following channel(s) was (were) selected for the final test as listed below.

EUT Configure Mode	Available Frequency (MHz)	Tested Frequency (MHz)	Date Rate (Mbps)
-	2402 to 2480	2402, 2440, 2480	1
-	2402 to 2480	2402, 2440, 2480	2

Radiated Spurious Emissions (Above 1 GHz)

- Pre-Scan full test was applied on all test modes, but only worst case was shown.
- Following channel(s) was (were) selected for the final test as listed below.

EUT Configure Mode	Available Frequency (MHz)	Tested Frequency (MHz)	Date Rate (Mbps)
-	2402 to 2480	2402, 2440, 2480	1
-	2402 to 2480	2402, 2440, 2480	2

Radiated Spurious Emissions (Below 1 GHz)

- Pre-Scan full test was applied on all test modes, but only worst case was shown.
- Following channel(s) was (were) selected for the final test as listed below.

EUT Configure Mode	Available Frequency (MHz)	Tested Frequency (MHz)	Date Rate (Mbps)
-	2402 to 2480	2480	1

Test Condition

Test Item	Ambient Temperature	Relative Humidity	Tested by
Conducted Measurement	24.1-25.1 °C	62.7-64.5 %	Zeke Wang
Radiated Spurious Emissions above 1 GHz	23.4-25.8 °C	55-59 %	Chuan Chu
Radiated Spurious Emissions below 1 GHz	23.4-25.8 °C	55-59 %	Chuan Chu

Prüfbericht-Nr.: CN24U0Y7 001
Test report no.:

 Seite 14 von 25
 Page 14 of 25

4.4 Special Accessories and Auxiliary Equipment

The product has been tested together with the following additional accessories:

Accessory of EUT

No.	Product	Brand	Model	Description
-	USB Wireless Dongle	HYPERS	HXWD232	--
-	Battery	Duracell	MN2400	1.5 Vdc, 40 mAh

Support Unit

Support Unit								
No	Description	Brand	Model	S/N	Shielded	Ferrite Core (Qty)	Length (cm)	Remark
A	UART	HP	HP-001	N/A	-	-	-	--
1	Cable	TUV	TUV-001	N/A	-	-	150	--
2	NoteBook	HP	15-da1046TX	CND9111RJB	-	-	-	--

4.5 Test Setup Diagram

<Radiated Spurious Emissions mode>

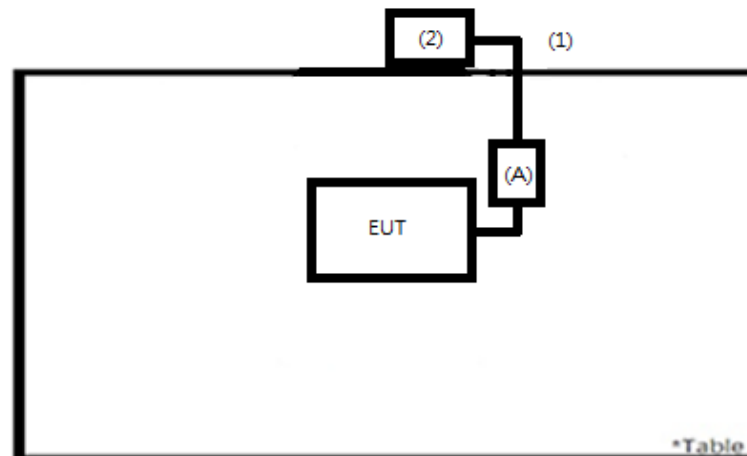

Prüfbericht-Nr.: CN24U0Y7 001
Test report no.:Seite 15 von 25
Page 15 of 25

5. Test Results

5.1 Transmitter Requirement & Test Suites

5.1.1 Antenna Requirement

Requirement Use of approved antennas only

According to the manufacturer declaration, the EUT has an antenna with a directional gain of 0.67 dBi. The antenna is PCB antenna with no possibility of replacement with a non-approved antenna by the end-user. Therefore, the EUT is considered to comply with this provision.
Refer to EUT photo for details.

Prüfbericht-Nr.: CN24U0Y7 001
Test report no.:

 Seite 16 von 25
 Page 16 of 25

5.1.2 Peak Output Power

Limit 1 watt (30 dBm)

Kind of Test Site Shielded room

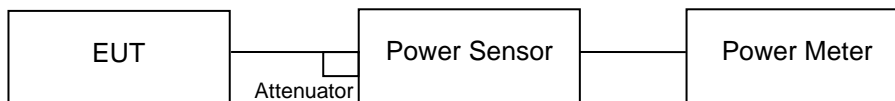
Test Setup

Test Instruments

Kind of Equipment	Manufacturer	Type	S/N	Calibration Date	Calibration Due Date	Test Date	
						From	Until
Power Meter	Anritsu	ML2495A	1901008	2024/03/12	2025/03/11	2024/6/20	2024/7/8
Power Sensor	Anritsu	MA2411B	1725269	2024/03/12	2025/03/11	2024/6/20	2024/7/8

Test Procedures

A peak power sensor was used on the output port of the EUT. A power meter was used to read the response of the peak power sensor. Record the power level.

Average power sensor was used to perform output power measurement, trigger and gating function of wide band power meter is enabled to measure max output power of TX on burst. Duty factor is not added to measured value.

Prüfbericht-Nr.: CN24U0Y7 001
Test report no.:
Test Result
Peak Output Power
<1Mbps>

Channel	Channel Frequency	Peak Output Power		Limit (dBm)
	(MHz)	(dBm)	(mW)	
Low Channel	2402	3.28	2.13	30
Middle Channel	2440	3.48	2.23	30
High Channel	2480	3.98	2.50	30

<2Mbps>

Channel	Channel Frequency	Peak Output Power		Limit (dBm)
	(MHz)	(dBm)	(mW)	
Low Channel	2402	3.39	2.18	30
Middle Channel	2440	3.41	2.19	30
High Channel	2480	3.62	2.30	30

Average Power
<1Mbps>

Channel	Channel Frequency	Average Power	
	(MHz)	(dBm)	(mW)
Low Channel	2402	2.86	1.93
Middle Channel	2440	3.06	2.02
High Channel	2480	3.15	2.07

<2Mbps>

Channel	Channel Frequency	Average Power	
	(MHz)	(dBm)	(mW)
Low Channel	2402	2.85	1.93
Middle Channel	2440	3.05	2.02
High Channel	2480	3.13	2.06

Prüfbericht-Nr.: CN24U0Y7 001
Test report no.:

 Seite 18 von 25
 Page 18 of 25

5.1.3 6 dB Bandwidth and 99% Occupied Bandwidth

Limit The minimum 6 dB bandwidth shall be at least 500 kHz.

Kind of Test Site Shielded room

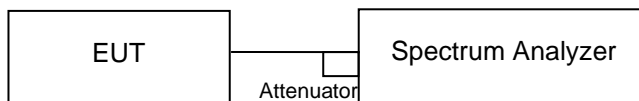
Test Setup

Test Instruments

Kind of Equipment	Manufacturer	Type	S/N	Calibration Date	Calibration Due Date	Test Date	
						From	Until
Spectrum Analyzer	R&S	FSV	101513	2024/05/09	2025/05/08	2024/6/20	2024/7/8

Test Procedure

- a. Set resolution bandwidth (RBW) = 100 kHz
- b. Set the video bandwidth (VBW) $\geq 3 \times$ RBW, Detector = Peak.
- c. Trace mode = max hold.
- d. Sweep = auto couple.
- e. Measure the maximum width of the emission that is constrained by the frequencies associated with the two amplitude points (upper and lower) that are attenuated by 6 dB relative to the maximum level measured in the fundamental emission.
- f. For 99% occupied bandwidth measurement, the transmitter output was connected to the spectrum analyzer through an attenuator. The bandwidth of the fundamental frequency was measured by spectrum analyzer with resolution bandwidth in the range of 1% to 5% of the anticipated emission bandwidth, and a video bandwidth at least 3x the resolution bandwidth and set the detector to PEAK. The width of a frequency band such that, below the lower and above the upper frequency limits, the mean powers emitted are each equal to a specified percentage 0.5% of the total mean power of a given emission.

Test Results

Please refer to Appendix A.

Prüfbericht-Nr.: CN24U0Y7 001
Test report no.:

 Seite 19 von 25
 Page 19 of 25

5.1.4 Power Spectral Density

Limit

The power spectral density shall not be greater than 8 dBm in any 3 kHz band.

Kind of Test Site Shielded room

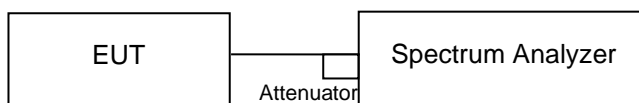
Test Setup

Test Instruments

Kind of Equipment	Manufacturer	Type	S/N	Calibration Date	Calibration Due Date	Test Date	
						From	Until
Spectrum Analyzer	R&S	FSV	101513	2024/05/09	2025/05/08	2024/6/20	2024/7/8

Test Procedure

- a. Set analyzer center frequency to DTS channel center frequency.
- b. Set the span to 1.5 times the DTS bandwidth.
- c. Set the RBW to: $3 \text{ kHz} \leq \text{RBW} \leq 100 \text{ kHz}$.
- d. Set the VBW $\geq 3 \times \text{RBW}$.
- e. Detector = peak.
- f. Sweep time = auto couple.
- g. Trace mode = max hold.
- h. Allow trace to fully stabilize.
- i. Use the peak marker function to determine the maximum amplitude level within the RBW.

Test Results

Please refer to Appendix A.

Prüfbericht-Nr.: CN24U0Y7 001
Test report no.:

 Seite 20 von 25
 Page 20 of 25

5.1.5 Conducted Spurious Emissions and Frequency Band Edges Measured in 100kHz Bandwidth

Limit

20dB (below that in the 100 kHz bandwidth within the band that contains the highest level of the desired power.)

Kind of Test Site Shielded room

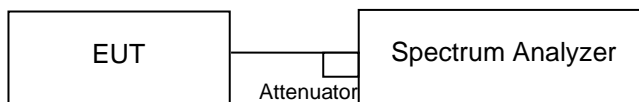
Test Setup

Test Instruments

Kind of Equipment	Manufacturer	Type	S/N	Calibration Date	Calibration Due Date	Test Date	
						From	Until
Spectrum Analyzer	R&S	FSV	101513	2024/05/09	2025/05/08	2024/6/20	2024/7/8

Test Procedure

Measurement procedure REF

1. Set the RBW = 100 kHz.
2. Set the VBW \geq 300 kHz.
3. Detector = peak.
4. Sweep time = auto couple.
5. Trace mode = max hold.
6. Allow trace to fully stabilize.
7. Use the peak marker function to determine the maximum power level in any 100 kHz band segment within the fundamental EBW.

Measurement procedure OOBE

1. Set RBW = 100 kHz.
2. Set VBW \geq 300 kHz.
3. Detector = peak.
4. Sweep = auto couple.
5. Trace Mode = max hold.
6. Allow trace to fully stabilize.
7. Use the peak marker function to determine the maximum amplitude level.

Test Results

Please refer to Appendix A.

5.1.6 Radiated Spurious Emissions and Band Edges

Limit

Radiated emissions which fall in the restricted bands, as defined in §15.205(a), must comply with the radiated emission limits specified in §15.209(a).

Emissions radiated outside the restricted and authorized frequency bands must either comply with the radiated emission limits specified for the restricted bands or in §15.247(d).

Kind of Test Site 3m Semi-Anechoic Chamber

Test Setup

<Radiated Emissions below 30 MHz>

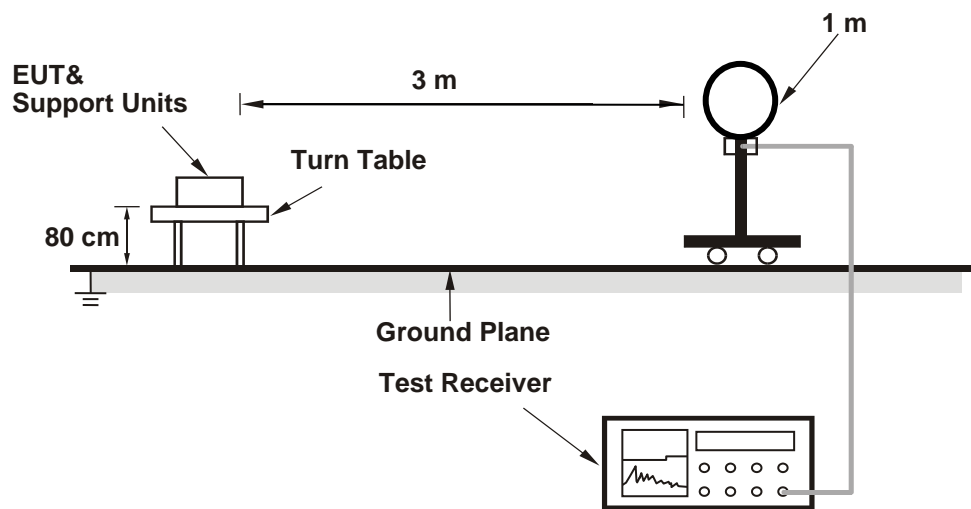

<Radiated Emissions 30 MHz to 1 GHz>

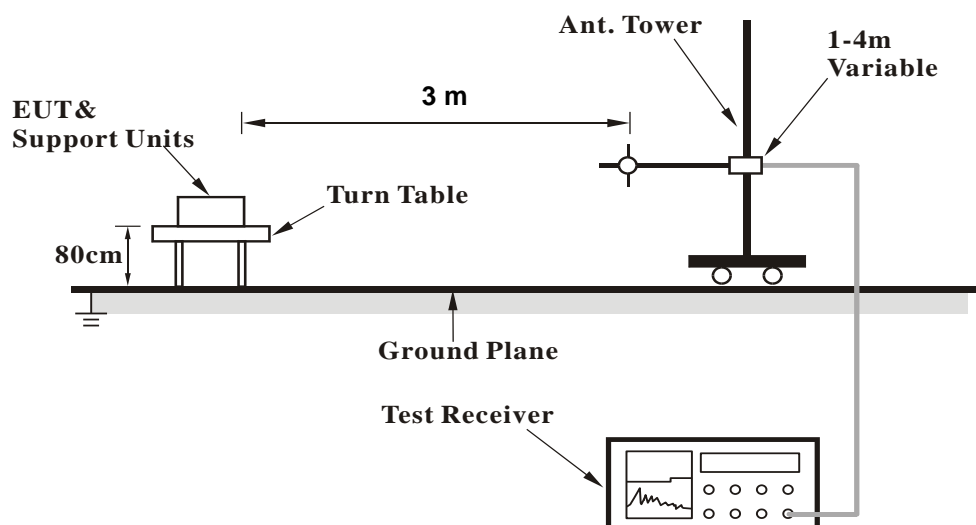

Prüfbericht-Nr.: CN24U0Y7 001
Test report no.:Seite 22 von 25
Page 22 of 25

<Radiated Emissions above 1 GHz>

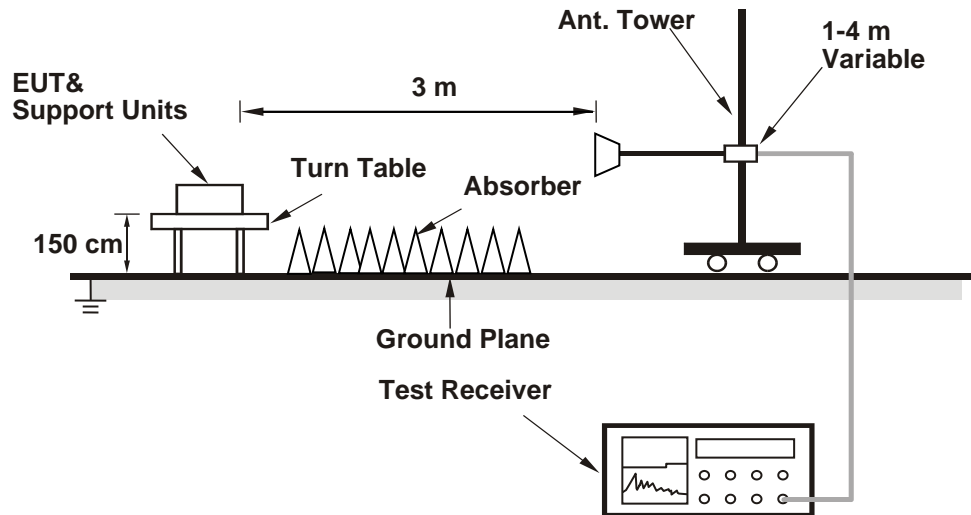

For the actual test configuration, please refer to the attached file (Test Setup Photo).

Prüfbericht-Nr.: CN24U0Y7 001
Test report no.:
Test Instruments

Kind of Equipment	Manufacturer	Type	S/N	Calibration Date	Calibration Due Date
Above 1 GHz					
Signal Analyzer	R&S	FSV40	101509	2024/4/24	2025/4/23
Horn Antenna	ETS-Lindgren	3117	00218930	2024/2/22	2025/2/21
Amplifier	EM	EM01G18GA	60967	2024/4/2	2025/4/1
HF-AMP + AC source	EMCI	EMC184045SE	980657	2024/1/24	2025/1/23
Horn Antenna	SCHWARZBECK	BBHA 9170	00890	2024/5/2	2025/5/1
Test Software	Audix E3	15914a_20191106 tuv	PK-001087	N/A	N/A
30 MHz ~ 1 GHz					
Receiver	R&S	ESR7	102109	2024/2/23	2025/2/22
Bilog Antenna	SCHWARZBECK	VULB-9168	00951	2024/3/29	2025/3/28
LF-AMP	Agilent	8447D	2944a107722	2024/3/20	2025/3/19
Test Software	Audix E3	15914a_20191106 tuv	PK-001087	N/A	N/A
Below 30 MHz					
Receiver	R&S	ESR7	102109	2024/2/23	2025/2/22
Loop Antenna	SCHWARZBECK	FMZB 1519B	00215	2024/1/4	2025/1/3
Test Software	Audix E3	15914a_20191106 tuv	PK-001087	N/A	N/A

Prüfbericht-Nr.: CN24U0Y7 001
Test report no.:Seite 24 von 25
Page 24 of 25**Test Procedures****For Radiated Emissions below 30 MHz**

- a. The EUT was placed on the top of a rotating table 0.8 meters above the ground at a 3 meter chamber room. The table was rotated 360 degrees to determine the position of the highest radiation.
- b. The EUT was set 3 meters away from the interference-receiving antenna, which was mounted on the top of a variable-height antenna tower.
- c. Parallel (OPEN), perpendicular (CLOSE), and ground-parallel (GROUND) orientations of the antenna are set to make the measurement.
- d. For each suspected emission, the EUT was arranged to its worst case and the rotatable table was turned from 0 degrees to 360 degrees to find the maximum reading.
- e. The test-receiver system was set to Quasi-Peak Detect Function and Specified Bandwidth with Maximum Hold Mode.

Note:

1. The resolution bandwidth and video bandwidth of test receiver/spectrum analyzer is 9 kHz at frequency below 30 MHz.
2. All modes of operation were investigated and the worst-case emissions are reported.

For Radiated Emissions above 30 MHz

- a. The EUT was placed on the top of a rotating table 0.8 meters (for 30 MHz ~ 1 GHz) / 1.5 meters (for above 1 GHz) above the ground at 3 meter chamber room for test. The table was rotated 360 degrees to determine the position of the highest radiation.
- b. The EUT was set 3 meters away from the interference-receiving antenna, which was mounted on the top of a variable-height antenna tower.
- c. The height of antenna is varied from one meter to four meters above the ground to determine the maximum value of the field strength. Both horizontal and vertical polarizations of the antenna are set to make the measurement.
- d. For each suspected emission, the EUT was arranged to its worst case and then the antenna was tuned to heights from 1 meter to 4 meters and the rotatable table was turned from 0 degrees to 360 degrees to find the maximum reading.
- e. The test-receiver system was set to quasi-peak detect function and specified bandwidth with maximum hold mode when the test frequency is below 1 GHz.
- f. The test-receiver system was set to peak and average detected function and specified bandwidth with maximum hold mode when the test frequency is above 1 GHz. If the peak reading value also meets average limit, measurement with the average detector is unnecessary.

Note:

1. The resolution bandwidth and video bandwidth of test receiver/spectrum analyzer is 120 kHz for Quasi-peak detection (QP) or Peak detection (PK) at frequency below 1 GHz.
2. The resolution bandwidth of test receiver/spectrum analyzer is 1 MHz and the video bandwidth is 3 MHz for Peak detection (PK) at frequency above 1 GHz.
3. The resolution bandwidth of test receiver/spectrum analyzer is 1 MHz and the video bandwidth is $\geq 1/T$ (Duty cycle $< 98\%$) or 10 Hz (Duty cycle $\geq 98\%$) for Average detection (AV) at frequency above 1 GHz.
4. All modes of operation were investigated and the worst-case emissions are reported.
5. The Radiated Emissions testing was performed in the X(E1), Y(H) and Z(E2) axis orientation. The worst-case Axis orientation is recorded in this test report.
6. The emission levels of other frequencies (including the 10th harmonic of the highest fundamental frequency) are very lower than the limit and are not shown in the test report.

Prüfbericht-Nr.: **CN24U0Y7 001**
Test report no.:

Seite 25 von 25
Page 25 of 25

Test Results

Factor (dB/m) = Antenna Factor (dB/m) + Cable Loss (dB) – Amplifier (dB)

Level (dBuV/m) = Reading (dBuV) + Factor (dB/m)

Please refer to Appendix B.

Appendix A: Test Results of Conducted Test

Test Result of 6 dB Bandwidth

BLE_1M

Channel	Channel Frequency (MHz)	6 dB Bandwidth (MHz)	Limit (MHz)	Result
Low Channel	2402	0.71	0.5	Pass
Middle Channel	2440	0.73	0.5	Pass
High Channel	2480	0.74	0.5	Pass

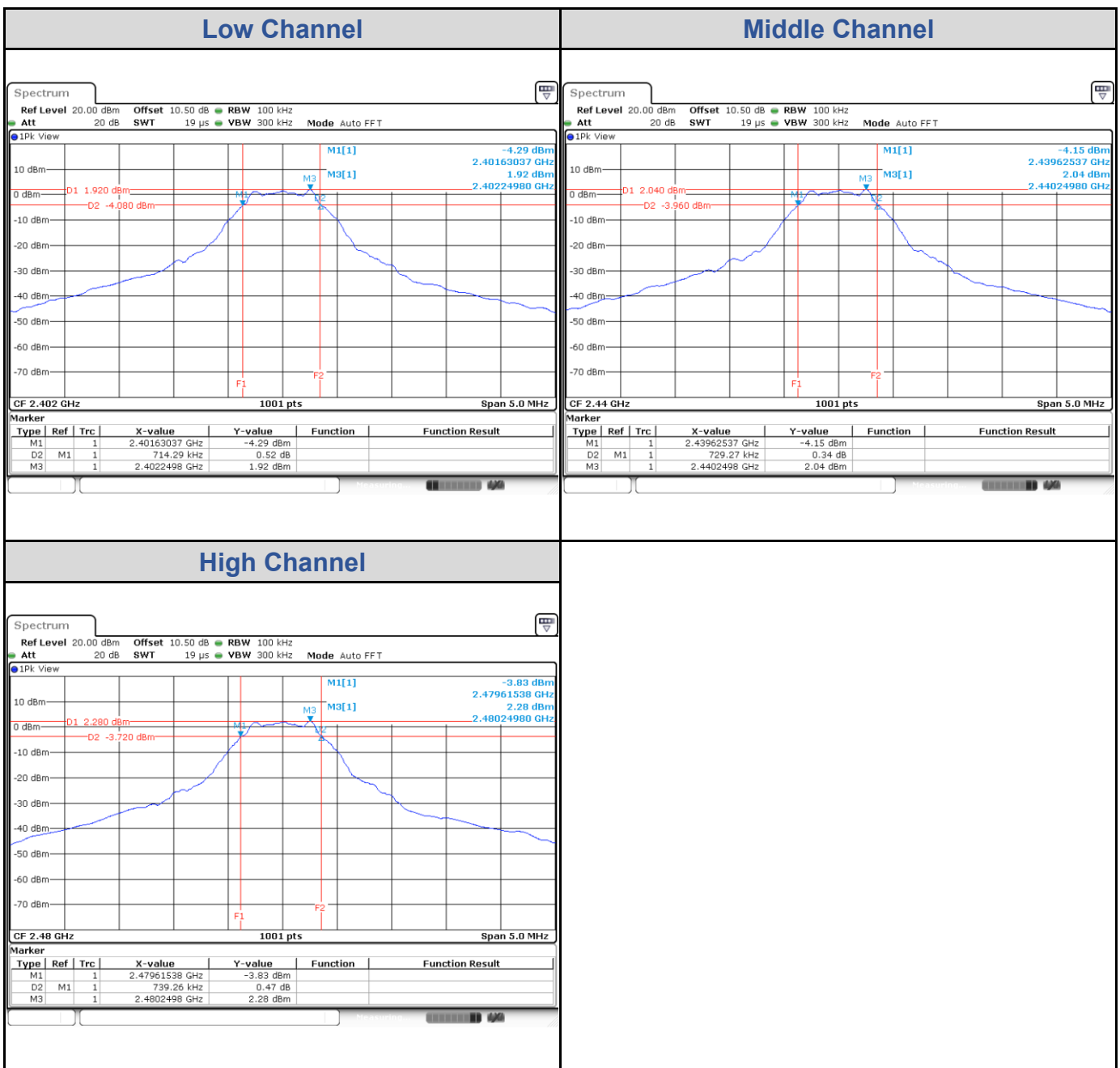

BLE_2M

Channel	Channel Frequency (MHz)	6 dB Bandwidth (MHz)	Limit (MHz)	Result
Low Channel	2402	1.27	0.5	Pass
Middle Channel	2440	1.27	0.5	Pass
High Channel	2480	1.31	0.5	Pass

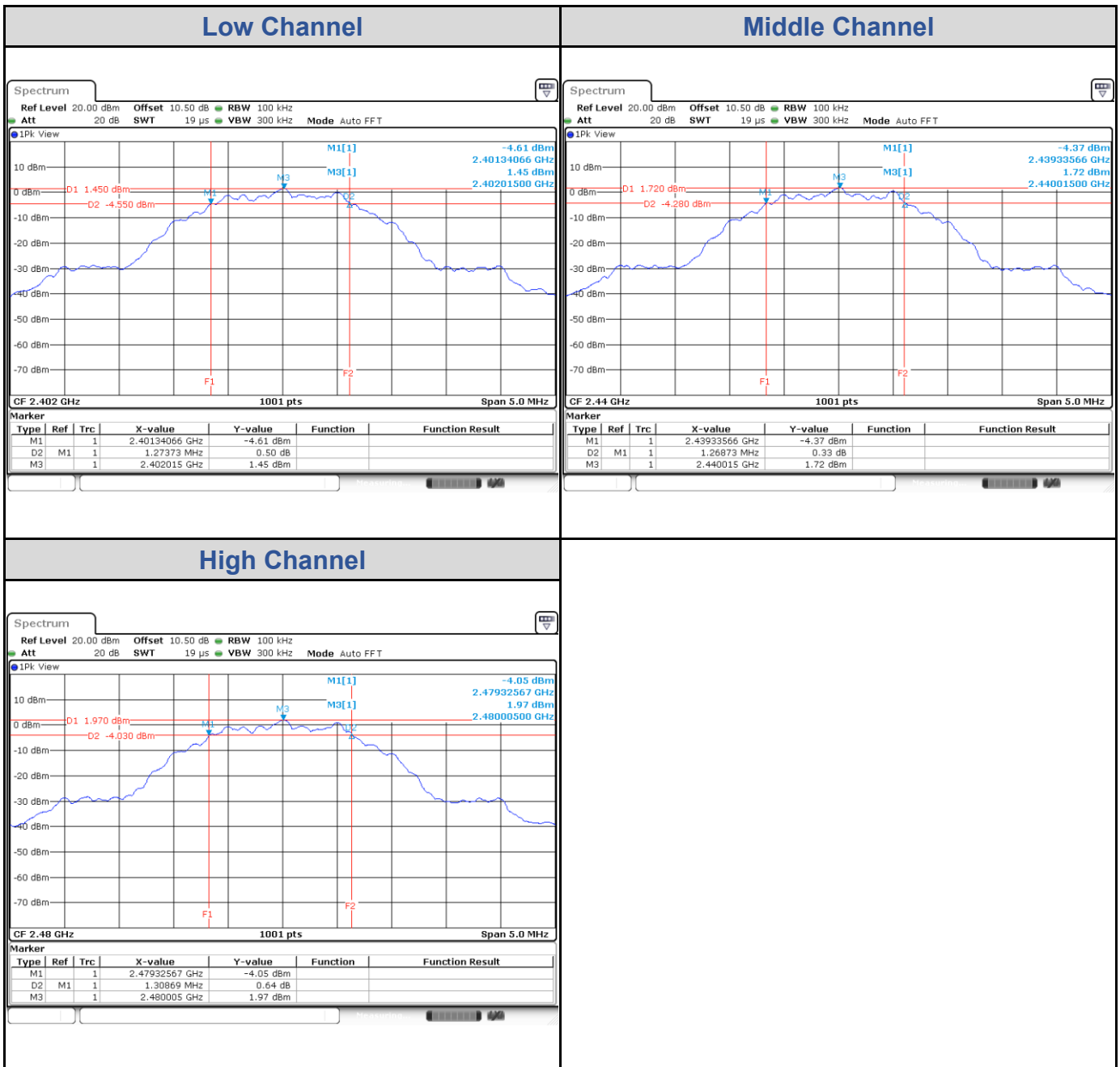

Test Result of 99% Occupied Bandwidth

BLE_1M

Channel	Channel Frequency (MHz)	99% Bandwidth (MHz)
Low Channel	2402	1.07
Middle Channel	2440	1.07
High Channel	2480	1.07

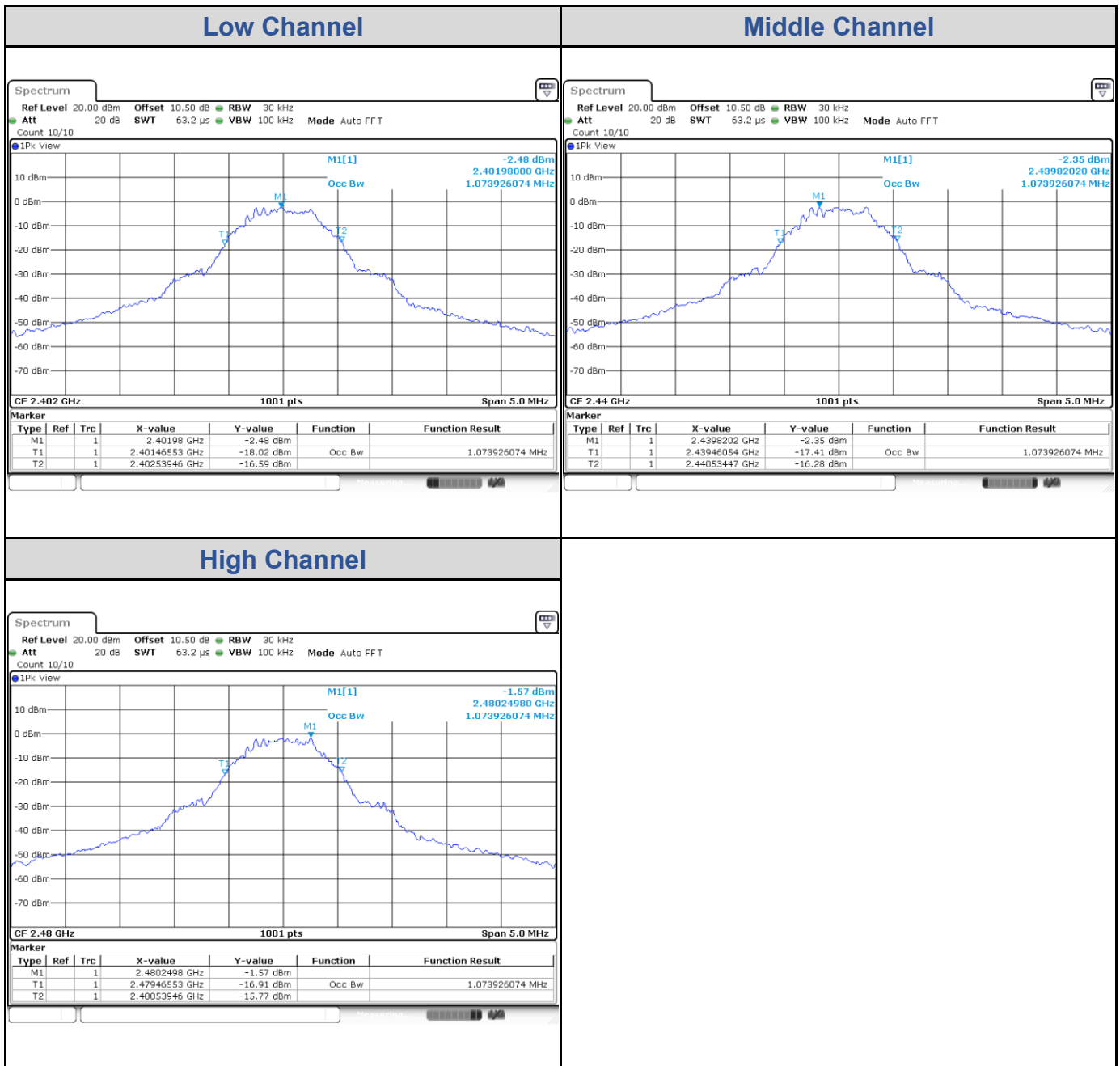

BLE_2M

Channel	Channel Frequency (MHz)	99% Bandwidth (MHz)
Low Channel	2402	2.06
Middle Channel	2440	2.07
High Channel	2480	2.06

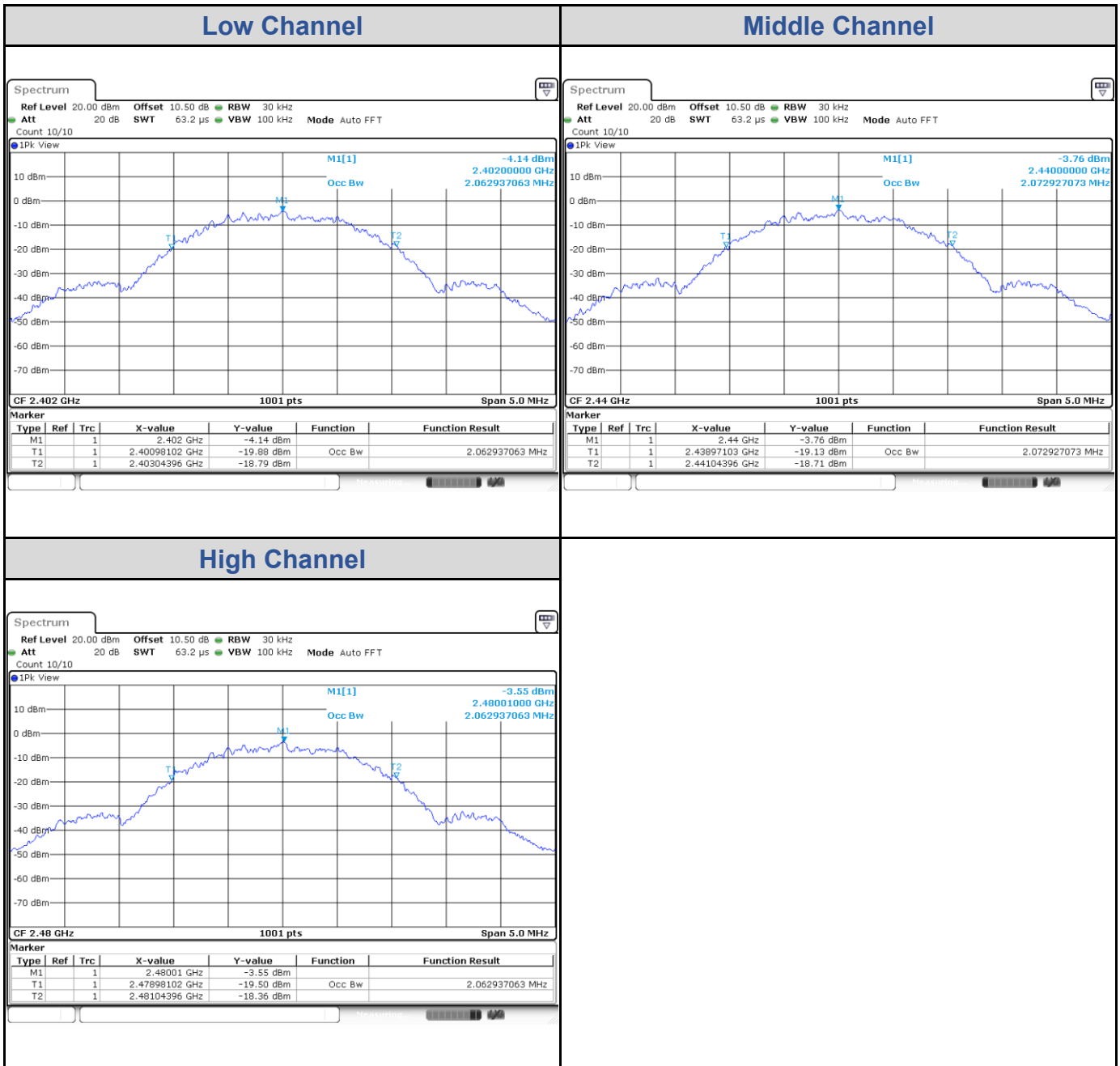

Test Result of Power Spectral Density

BLE_1M

Channel	Channel Frequency (MHz)	Power Density (dBm)	Limit (dBm)	Result
Low Channel	2402	-11.81	8	Pass
Middle Channel	2440	-11.52	8	Pass
High Channel	2480	-11.94	8	Pass

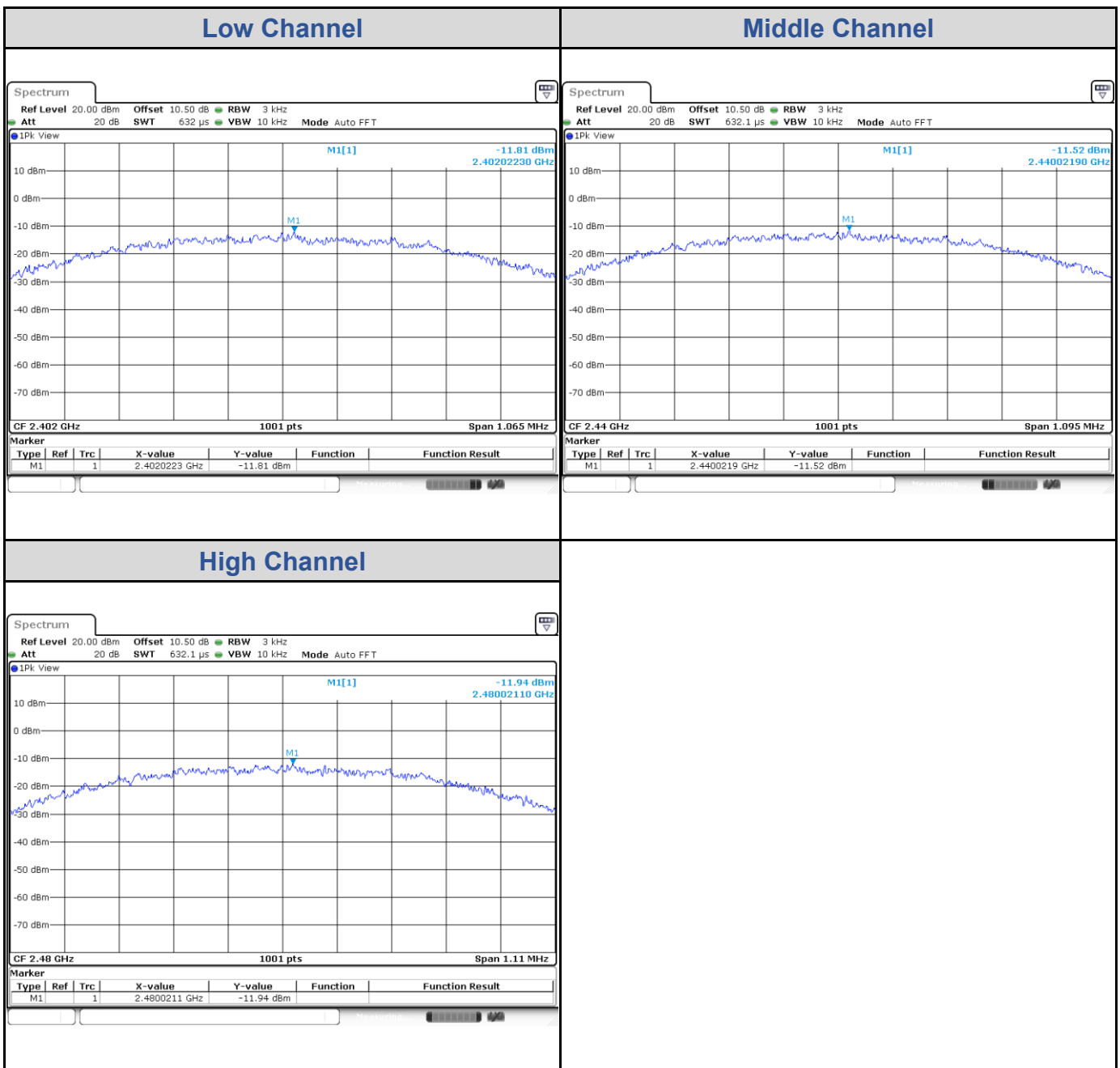

BLE_2M

Channel	Channel Frequency (MHz)	Power Density (dBm)	Limit (dBm)	Result
Low Channel	2402	-15.40	8	Pass
Middle Channel	2440	-15.50	8	Pass
High Channel	2480	-15.05	8	Pass

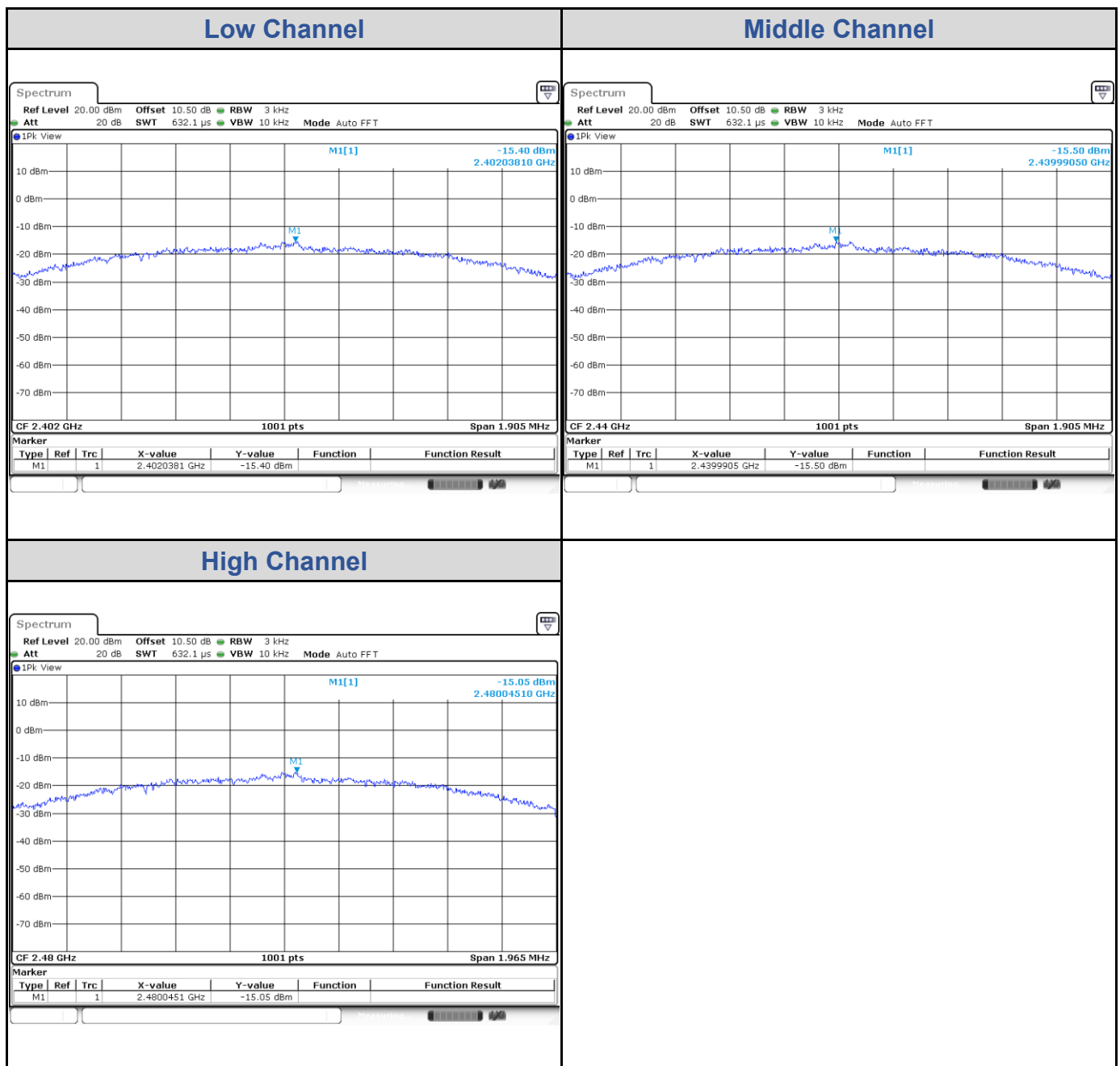

Test Result of Conducted Spurious Emissions

BLE_1M

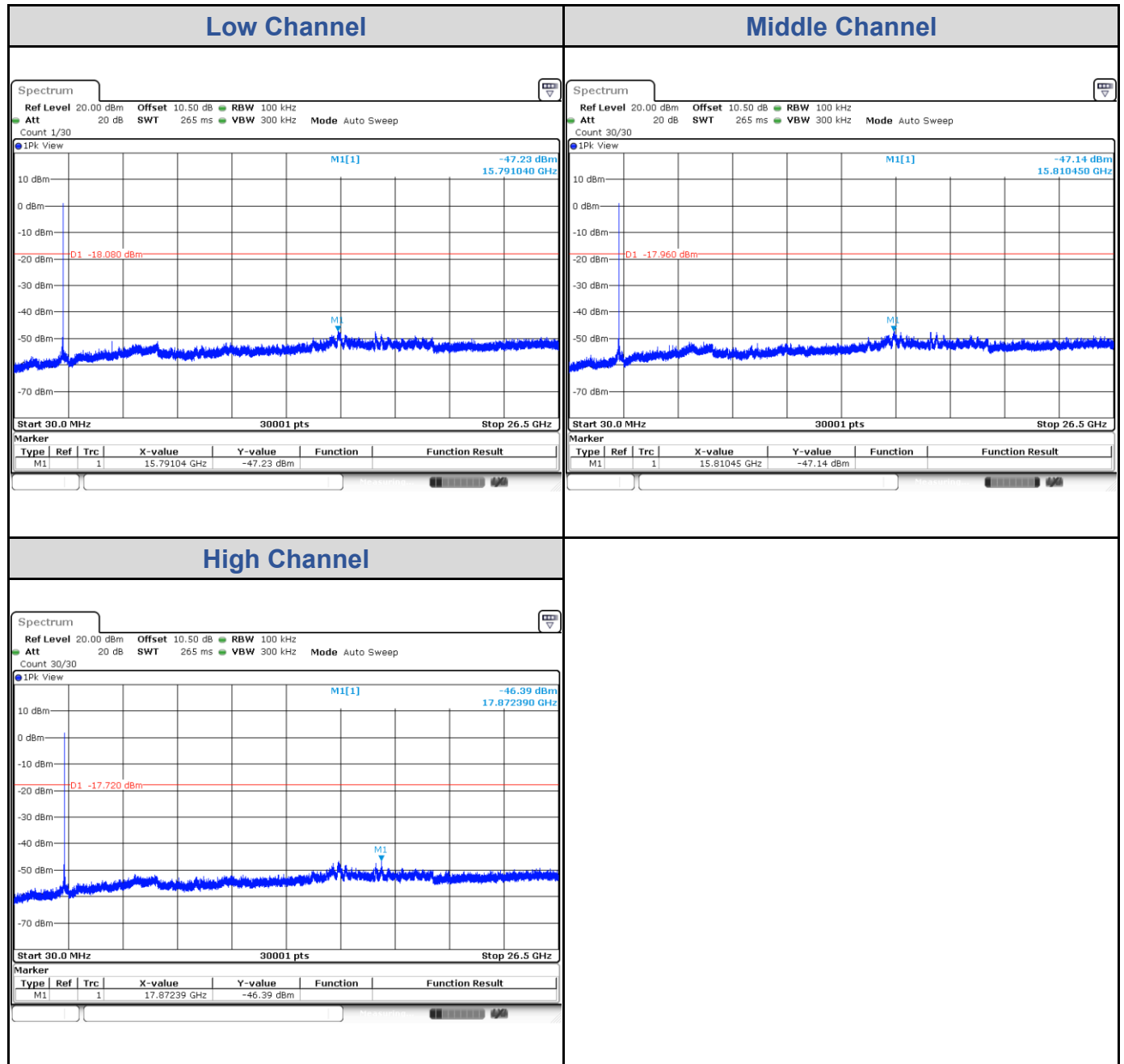

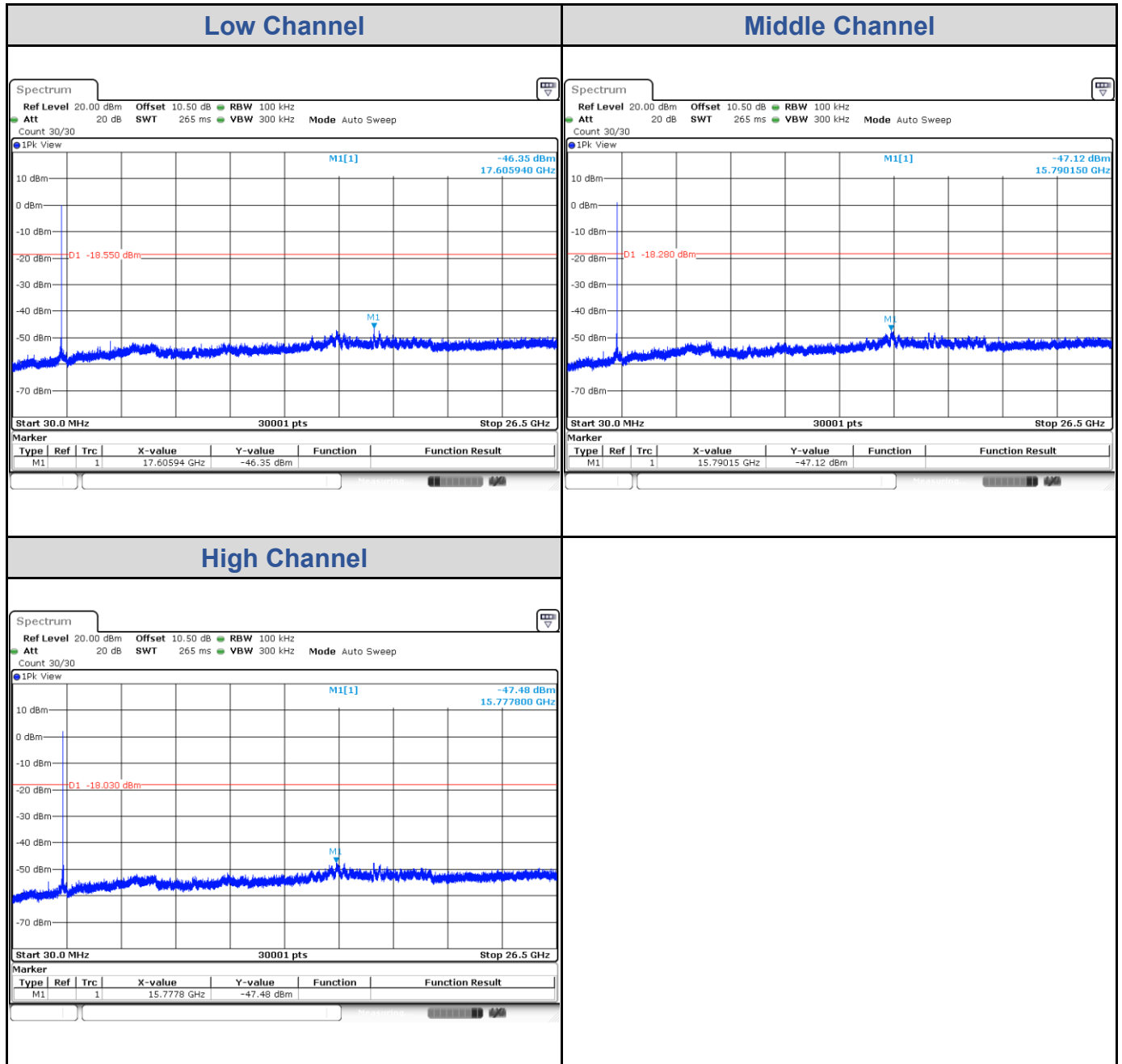
BLE_2M

Test Result of Conducted Band Edge

BLE_1M

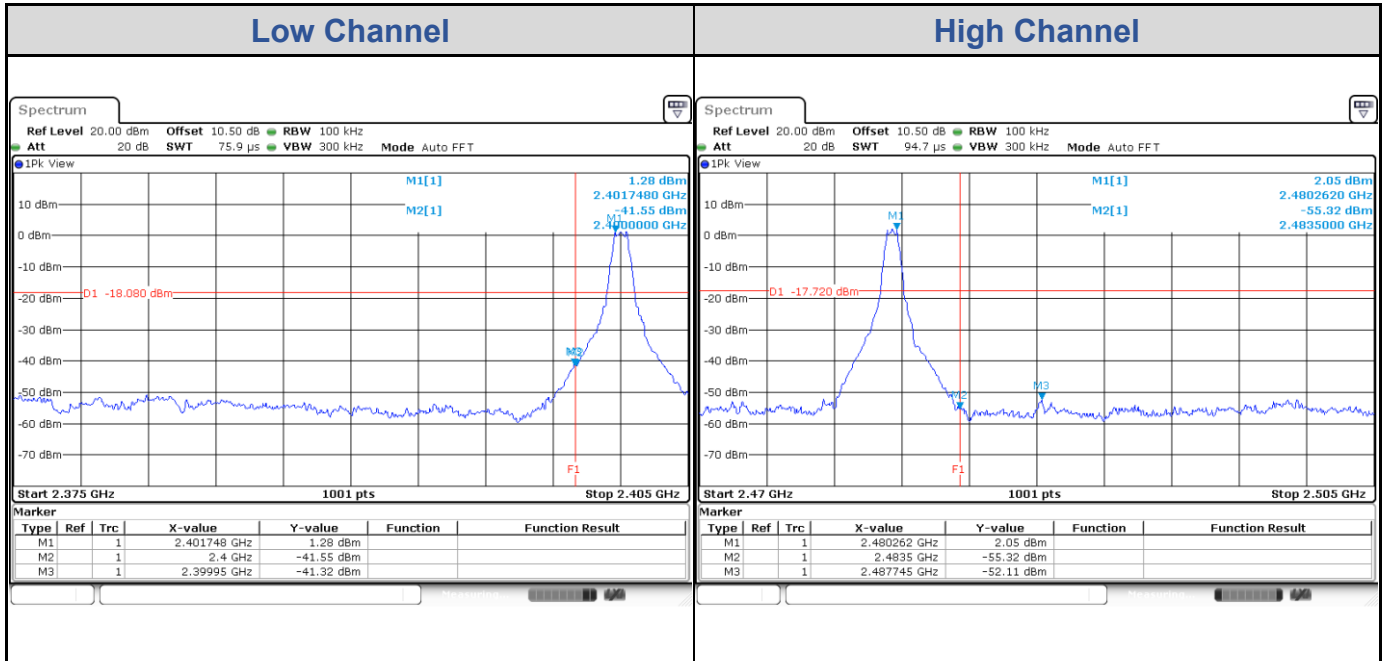

BLE_2M

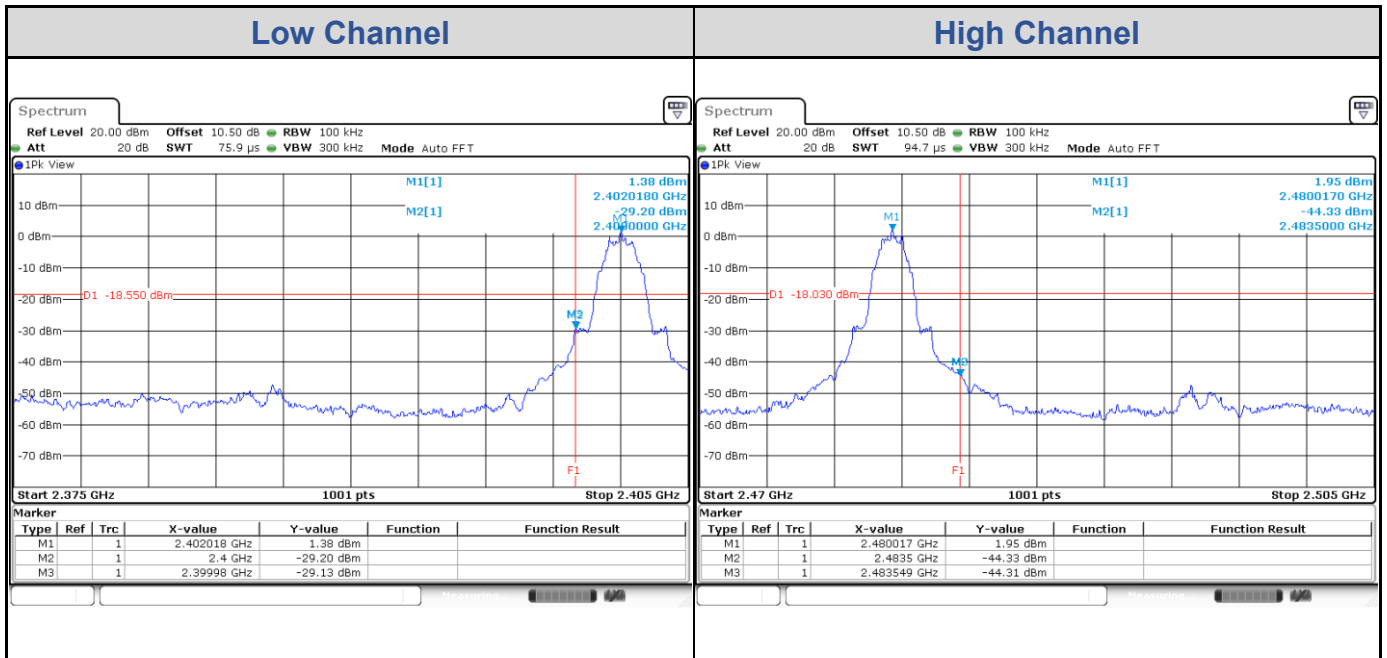

Appendix B: Test Results of Radiated Spurious Emissions

Band Edges, 2.31GHz ~ 2.9GHz

BLE_1M

Low Channel (Horizontal) Peak	Low Channel (Vertical) Peak																																																																																																				
<div style="text-align: right; font-size: small; margin-bottom: 5px;"> TÜV Rheinland Taiwan Ltd. No. 438-18, Sec. 2, Fenliao, Linkou Dist., New Taipei City 244, Taiwan(R.O.C.) Tel: +886-2172-1000 Fax: +886-2172-1322 </div> <div style="text-align: center; margin-bottom: 10px;"> </div> <div style="text-align: right; font-size: x-small; margin-bottom: 5px;"> Date: 2024-06-26 </div> <table border="1" style="width: 100%; border-collapse: collapse; font-size: x-small;"> <thead> <tr> <th>Freq</th> <th>Level</th> <th>Read</th> <th>Limit</th> <th>Over</th> <th>APos</th> <th>TPos</th> <th>Remark</th> <th>Pol/Phase</th> <th>Note</th> </tr> <tr> <th>MHz</th> <th>dBuV/m</th> <th>dBuV</th> <th>dB/m</th> <th>dBuV/m</th> <th>dB</th> <th>cm</th> <th>deg</th> <th></th> <th></th> </tr> </thead> <tbody> <tr> <td>1</td> <td>2382.01</td> <td>55.48</td> <td>50.26</td> <td>5.22</td> <td>74.00</td> <td>-18.52</td> <td>296</td> <td>203 Peak</td> <td>Horizontal</td> </tr> <tr> <td>2 *</td> <td>2482.00</td> <td>99.28</td> <td>93.99</td> <td>5.29</td> <td>74.00</td> <td>25.28</td> <td>296</td> <td>203 Peak</td> <td>Horizontal</td> </tr> <tr> <td>3</td> <td>2488.52</td> <td>53.73</td> <td>48.20</td> <td>5.53</td> <td>74.00</td> <td>-20.27</td> <td>296</td> <td>203 Peak</td> <td>Horizontal</td> </tr> </tbody> </table>	Freq	Level	Read	Limit	Over	APos	TPos	Remark	Pol/Phase	Note	MHz	dBuV/m	dBuV	dB/m	dBuV/m	dB	cm	deg			1	2382.01	55.48	50.26	5.22	74.00	-18.52	296	203 Peak	Horizontal	2 *	2482.00	99.28	93.99	5.29	74.00	25.28	296	203 Peak	Horizontal	3	2488.52	53.73	48.20	5.53	74.00	-20.27	296	203 Peak	Horizontal	<div style="text-align: right; font-size: small; margin-bottom: 5px;"> TÜV Rheinland Taiwan Ltd. No. 438-18, Sec. 2, Fenliao, Linkou Dist., New Taipei City 244, Taiwan(R.O.C.) Tel: +886-2172-1000 Fax: +886-2172-1322 </div> <div style="text-align: center; margin-bottom: 10px;"> </div> <div style="text-align: right; font-size: x-small; margin-bottom: 5px;"> Date: 2024-06-26 </div> <table border="1" style="width: 100%; border-collapse: collapse; font-size: x-small;"> <thead> <tr> <th>Freq</th> <th>Level</th> <th>Read</th> <th>Limit</th> <th>Over</th> <th>APos</th> <th>TPos</th> <th>Remark</th> <th>Pol/Phase</th> <th>Note</th> </tr> <tr> <th>MHz</th> <th>dBuV/m</th> <th>dBuV</th> <th>dB/m</th> <th>dBuV/m</th> <th>dB</th> <th>cm</th> <th>deg</th> <th></th> <th></th> </tr> </thead> <tbody> <tr> <td>1</td> <td>2374.37</td> <td>53.89</td> <td>48.68</td> <td>5.21</td> <td>74.00</td> <td>-20.11</td> <td>100</td> <td>13 Peak</td> <td>Vertical</td> </tr> <tr> <td>2 *</td> <td>2482.00</td> <td>95.01</td> <td>89.72</td> <td>5.29</td> <td>74.00</td> <td>21.01</td> <td>100</td> <td>13 Peak</td> <td>Vertical</td> </tr> <tr> <td>3</td> <td>2489.66</td> <td>53.55</td> <td>48.02</td> <td>5.53</td> <td>74.00</td> <td>-20.45</td> <td>100</td> <td>13 Peak</td> <td>Vertical</td> </tr> </tbody> </table>	Freq	Level	Read	Limit	Over	APos	TPos	Remark	Pol/Phase	Note	MHz	dBuV/m	dBuV	dB/m	dBuV/m	dB	cm	deg			1	2374.37	53.89	48.68	5.21	74.00	-20.11	100	13 Peak	Vertical	2 *	2482.00	95.01	89.72	5.29	74.00	21.01	100	13 Peak	Vertical	3	2489.66	53.55	48.02	5.53	74.00	-20.45	100	13 Peak	Vertical
Freq	Level	Read	Limit	Over	APos	TPos	Remark	Pol/Phase	Note																																																																																												
MHz	dBuV/m	dBuV	dB/m	dBuV/m	dB	cm	deg																																																																																														
1	2382.01	55.48	50.26	5.22	74.00	-18.52	296	203 Peak	Horizontal																																																																																												
2 *	2482.00	99.28	93.99	5.29	74.00	25.28	296	203 Peak	Horizontal																																																																																												
3	2488.52	53.73	48.20	5.53	74.00	-20.27	296	203 Peak	Horizontal																																																																																												
Freq	Level	Read	Limit	Over	APos	TPos	Remark	Pol/Phase	Note																																																																																												
MHz	dBuV/m	dBuV	dB/m	dBuV/m	dB	cm	deg																																																																																														
1	2374.37	53.89	48.68	5.21	74.00	-20.11	100	13 Peak	Vertical																																																																																												
2 *	2482.00	95.01	89.72	5.29	74.00	21.01	100	13 Peak	Vertical																																																																																												
3	2489.66	53.55	48.02	5.53	74.00	-20.45	100	13 Peak	Vertical																																																																																												

BLE_1M

Low Channel (Horizontal) Average

Low Channel (Vertical) Average

TÜVRheinland
TÜVRheinland Taiwan Ltd.
No. 438-18, Sec 2, Fenfiao, Linkou Dist., New Taipei City 244, Taiwan(R.O.C.)
Tel: +886-2172-1000 Fax: +886-2172-1322

TÜVRheinland
TÜVRheinland Taiwan Ltd.
No. 438-18, Sec 2, Fenfiao, Linkou Dist., New Taipei City 244, Taiwan(R.O.C.)
Tel: +886-2172-1000 Fax: +886-2172-1322

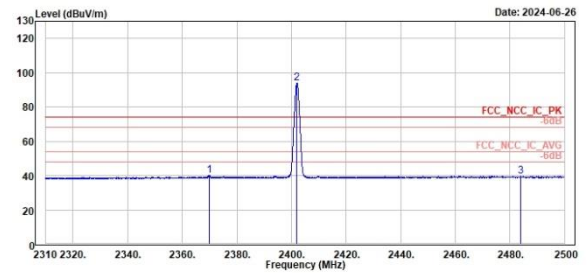
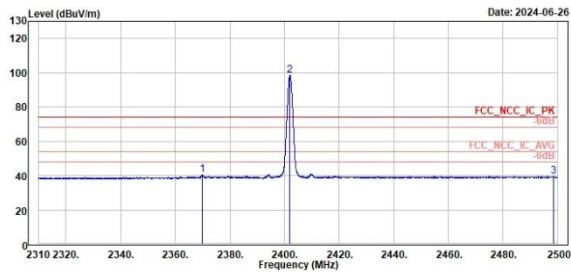

Freq	Level	Read	Limit	Over	APos	TPos	Remark	Pol/Phase	Note
MHz	dBuV/m	dBuV	dB/m	dBuV/m	dB	cm	deg		
1	2369.85	40.50	35.30	5.20	54.00	-13.50	296	203 Average	Horizontal
2 *	2402.00	98.23	92.94	5.29	54.00	44.23	296	203 Average	Horizontal
3	2498.44	39.44	33.91	5.53	54.00	-14.56	296	203 Average	Horizontal

Freq	Level	Read	Limit	Over	APos	TPos	Remark	Pol/Phase	Note
MHz	dBuV/m	dBuV	dB/m	dBuV/m	dB	cm	deg		
1	2369.96	39.95	34.75	5.20	54.00	-14.05	100	13 Average	Vertical
2 *	2402.00	93.95	88.66	5.29	54.00	39.95	100	13 Average	Vertical
3	2483.85	39.55	34.03	5.52	54.00	-14.45	100	13 Average	Vertical

BLE_1M

Middle Channel (Horizontal) Peak

Middle Channel (Vertical) Peak

TÜVRheinland
TUV Rheinland Taiwan Ltd.
No. 438-18, Sec 2, Fenfiao, Linkou Dist., New Taipei City 244, Taiwan(R.O.C.)
Tel: +886-2172-1000 Fax: +886-2172-1322

TÜVRheinland
TUV Rheinland Taiwan Ltd.
No. 438-18, Sec 2, Fenfiao, Linkou Dist., New Taipei City 244, Taiwan(R.O.C.)
Tel: +886-2172-1000 Fax: +886-2172-1322

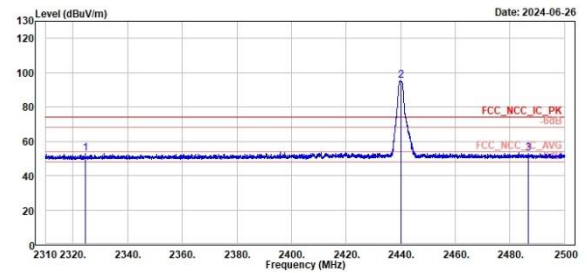
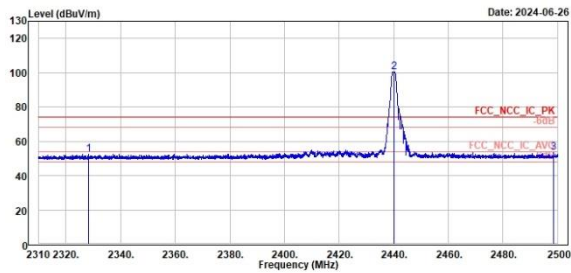

Peak	Freq	Level	Read Level	Factor	Limit Line	Over Limit	APos	TPos	Remark	Pol/Phase	Note
	MHz	dBuV/m	dBuV	dB/m	dBuV/m	dB	cm	deg			
1	2328.24	52.57	47.52	5.05	74.00	-21.43	325	206	Peak	Horizontal	
2 *	2440.00	100.56	95.10	5.46	74.00	26.56	325	206	Peak	Horizontal	
3	2498.48	53.15	47.62	5.53	74.00	-20.85	325	206	Peak	Horizontal	

Peak	Freq	Level	Read Level	Factor	Limit Line	Over Limit	APos	TPos	Remark	Pol/Phase	Note
	MHz	dBuV/m	dBuV	dB/m	dBuV/m	dB	cm	deg			
1	2324.55	52.84	47.80	5.04	74.00	-21.16	274	24	Peak	Vertical	
2 *	2440.00	95.16	89.78	5.46	74.00	21.16	274	24	Peak	Vertical	
3	2486.78	52.93	47.41	5.52	74.00	-21.07	274	24	Peak	Vertical	

BLE_1M

Middle Channel (Horizontal) Average

Middle Channel (Vertical) Average



TÜV Rheinland Taiwan Ltd.
No. 438-18, Sec 2, Fenfiao, Linkou Dist., New Taipei City 244, Taiwan(R.O.C.)
Tel: +886-2172-1000 Fax: +886-2172-1322

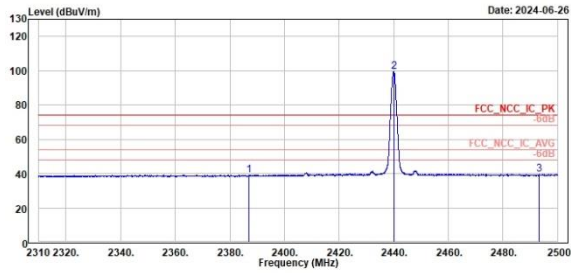

Freq	Level	Read	Limit	Over	APos	TPos	Remark	Pol/Phase	Note
MHz	dBuV/m	dBuV	dB/m	dBuV/m	dB	cm	deg		
1	2387.03	39.09	33.85	5.24	54.00	-14.91	325	206 Average	Horizontal
2 *	2440.00	99.52	94.08	5.46	54.00	45.52	325	206 Average	Horizontal
3	2493.35	39.40	33.88	5.52	54.00	-14.60	325	206 Average	Horizontal



TÜV Rheinland Taiwan Ltd.
No. 438-18, Sec 2, Fenfiao, Linkou Dist., New Taipei City 244, Taiwan(R.O.C.)
Tel: +886-2172-1000 Fax: +886-2172-1322

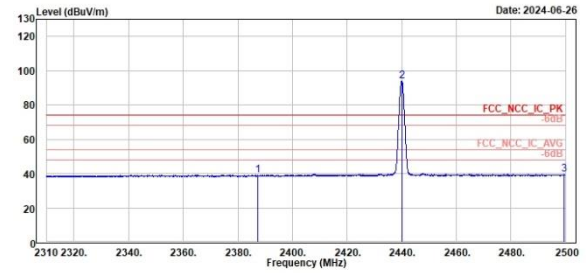

Freq	Level	Read	Limit	Over	APos	TPos	Remark	Pol/Phase	Note
MHz	dBuV/m	dBuV	dB/m	dBuV/m	dB	cm	deg		
1	2387.33	39.04	33.80	5.24	54.00	-14.96	274	24 Average	Vertical
2 *	2440.00	94.11	88.65	5.46	54.00	40.11	274	24 Average	Vertical
3	2499.43	39.51	33.98	5.53	54.00	-14.49	274	24 Average	Vertical

BLE_1M

High Channel (Horizontal) Peak

High Channel (Vertical) Peak

TÜVRheinland
TÜVRheinland Taiwan Ltd.
No. 438-18, Sec 2, Penfiao, Linkou Dist., New Taipei City 244, Taiwan(R.O.C.)
Tel: +886-2172-1000 Fax: +886-2172-1322

TÜVRheinland
TÜVRheinland Taiwan Ltd.
No. 438-18, Sec 2, Penfiao, Linkou Dist., New Taipei City 244, Taiwan(R.O.C.)
Tel: +886-2172-1000 Fax: +886-2172-1322

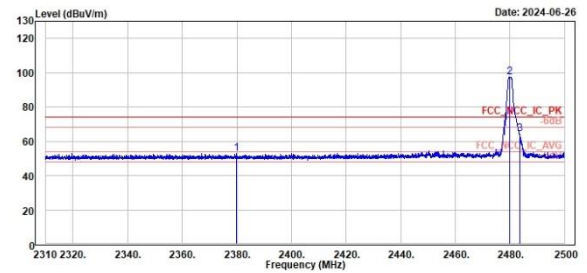
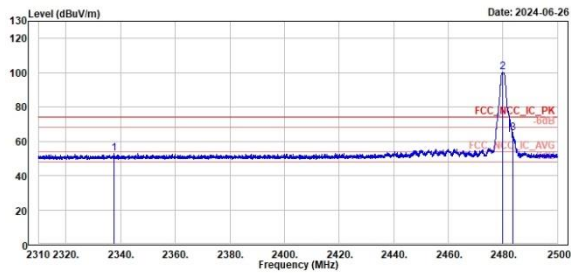

Peak	Freq (MHz)	Level (dBuV/m)	Read Level (dBuV)	Factor (dB/m)	Limit (dBuV/m)	Over Limit (dB)	APos (cm)	TPos (deg)	Remark	Pol/Phase	Note
1	2337.59	52.70	47.61	5.09	74.00	-21.30	353	199	Peak	Horizontal	
2 *	2480.00	100.11	94.59	5.52	74.00	26.11	353	199	Peak	Horizontal	
3	2483.51	64.52	59.00	5.52	74.00	-9.48	353	199	Peak	Horizontal	

Peak	Freq (MHz)	Level (dBuV/m)	Read Level (dBuV)	Factor (dB/m)	Limit (dBuV/m)	Over Limit (dB)	APos (cm)	TPos (deg)	Remark	Pol/Phase	Note
1	2379.81	52.97	47.75	5.22	74.00	-21.03	296	22	Peak	Vertical	
2 *	2480.00	97.62	92.18	5.52	74.00	23.62	296	22	Peak	Vertical	
3	2483.51	64.26	58.74	5.52	74.00	-9.74	296	22	Peak	Vertical	

BLE_1M

High Channel (Horizontal) Average

High Channel (Vertical) Average

TÜVRheinland
TUV Rheinland Taiwan Ltd.
No. 438-18, Sec 2, Fenfiao, Linkou Dist., New Taipei City 244, Taiwan(R.O.C.)
Tel: +886-2172-1000 Fax: +886-2172-1322

TÜVRheinland
TUV Rheinland Taiwan Ltd.
No. 438-18, Sec 2, Fenfiao, Linkou Dist., New Taipei City 244, Taiwan(R.O.C.)
Tel: +886-2172-1000 Fax: +886-2172-1322

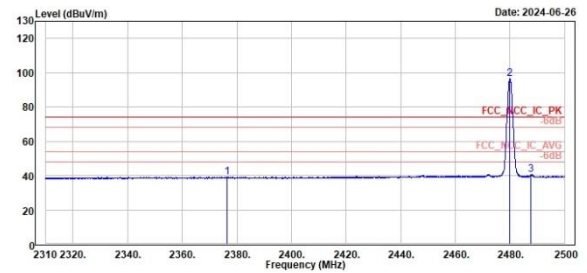
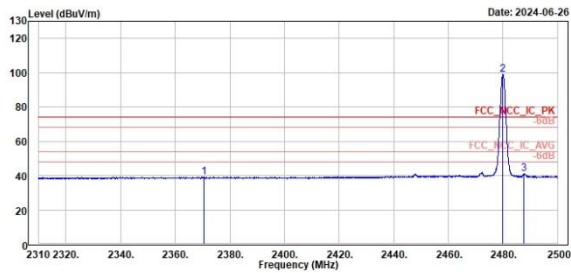

Freq	Level	Read Level	Factor	Limit Line	Over Limit	APos	TPos	Remark	Pol/Phase	Note
MHz	dBuV/m	dBuV	dB/m	dBuV/m	dB	cm	deg			
1	2376.65	39.13	33.93	5.20	54.00	-14.87	353	199 Average	Horizontal	
2 *	2480.00	99.05	93.53	5.52	54.00	45.05	353	199 Average	Horizontal	
3	2487.73	41.00	35.47	5.53	54.00	-13.00	353	199 Average	Horizontal	

Freq	Level	Read Level	Factor	Limit Line	Over Limit	APos	TPos	Remark	Pol/Phase	Note
MHz	dBuV/m	dBuV	dB/m	dBuV/m	dB	cm	deg			
1	2376.54	39.09	33.87	5.22	54.00	-14.91	296	22 Average	Vertical	
2 *	2480.00	96.62	91.18	5.52	54.00	42.62	296	22 Average	Vertical	
3	2487.57	40.51	34.98	5.53	54.00	-13.49	296	22 Average	Vertical	

BLE_2M

Low Channel (Horizontal) Peak

Low Channel (Vertical) Peak

TÜVRheinland
TUV Rheinland Taiwan Ltd.
No. 438-18, Sec 2, Fenfiao, Linkou Dist., New Taipei City 244, Taiwan(R.O.C.)
Tel: +886-2172-1000 Fax: +886-2172-1322

TÜVRheinland
TUV Rheinland Taiwan Ltd.
No. 438-18, Sec 2, Fenfiao, Linkou Dist., New Taipei City 244, Taiwan(R.O.C.)
Tel: +886-2172-1000 Fax: +886-2172-1322

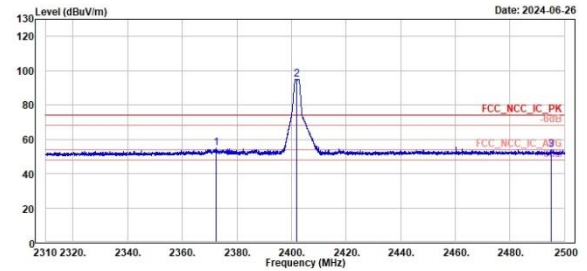
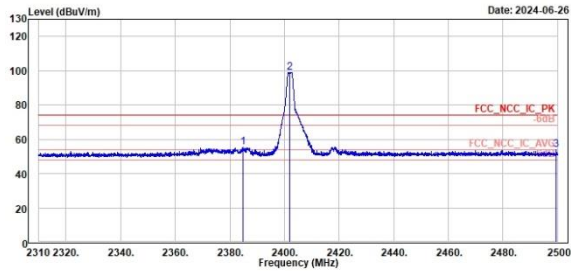

1	2	3
2384.78	2482.00	2499.54
55.30	99.06	54.01
50.06	93.77	48.48
5.24	5.29	5.53
74.00	74.00	74.00
-18.70	25.06	-19.99
297	297	297
208	208	208
Peak	Peak	Peak
Horizontal	Horizontal	Horizontal

1	2	3
2372.43	2482.00	2495.21
54.01	95.06	53.72
49.61	89.77	48.20
5.20	5.29	5.52
74.00	74.00	74.00
-19.19	21.06	-20.28
100	100	100
14	14	14
Peak	Peak	Peak
Vertical	Vertical	Vertical

BLE_2M

Low Channel (Horizontal) Average

Low Channel (Vertical) Average



TUV Rheinland Taiwan Ltd.
No. 438-18, Sec 2, FenHiao, Linkou Dist., New Taipei City 244, Taiwan(R.O.C.)
Tel: +886-2172-1000 Fax: +886-2172-1322

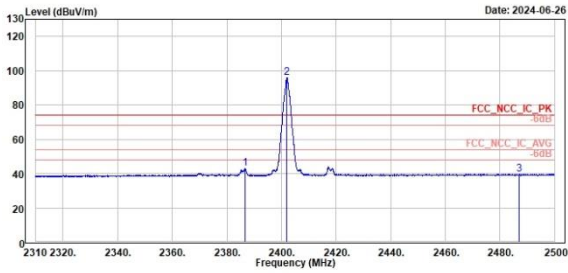

Freq	Level	Read Level	Factor	Limit Line	Over Limit	APos	TPos	Remark	Pol/Phase	Note
MHz	dBuV/m	dBuV	dB/m	dBuV/m	dB	cm	deg			
1	2386.61	43.02	37.78	5.24	54.00	-10.98	297	208 Average	Horizontal	
2 *	2402.00	96.09	90.89	5.29	54.00	42.09	297	208 Average	Horizontal	
3	2487.08	39.59	34.06	5.53	54.00	-14.41	297	208 Average	Horizontal	



TUV Rheinland Taiwan Ltd.
No. 438-18, Sec 2, FenHiao, Linkou Dist., New Taipei City 244, Taiwan(R.O.C.)
Tel: +886-2172-1000 Fax: +886-2172-1322

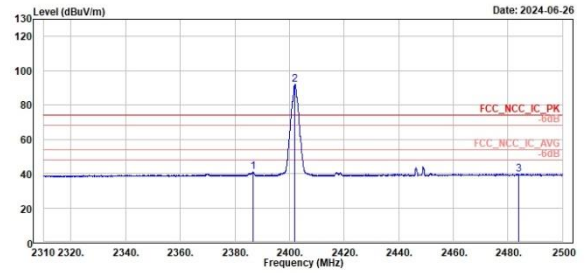

Freq	Level	Read Level	Factor	Limit Line	Over Limit	APos	TPos	Remark	Pol/Phase	Note
MHz	dBuV/m	dBuV	dB/m	dBuV/m	dB	cm	deg			
1	2386.65	40.83	35.59	5.24	54.00	-13.17	100	14 Average	Vertical	
2 *	2402.00	92.09	86.89	5.29	54.00	38.09	100	14 Average	Vertical	
3	2483.85	39.59	34.07	5.52	54.00	-14.41	100	14 Average	Vertical	

BLE_2M

Middle Channel (Horizontal) Peak

Middle Channel (Vertical) Peak

TÜVRheinland
TUV Rheinland Taiwan Ltd.
No. 438-18, Sec 2, Fenfiao, Linkou Dist., New Taipei City 244, Taiwan(R.O.C.)
Tel: +886-2172-1000 Fax: +886-2172-1322

TÜVRheinland
TUV Rheinland Taiwan Ltd.
No. 438-18, Sec 2, Fenfiao, Linkou Dist., New Taipei City 244, Taiwan(R.O.C.)
Tel: +886-2172-1000 Fax: +886-2172-1322

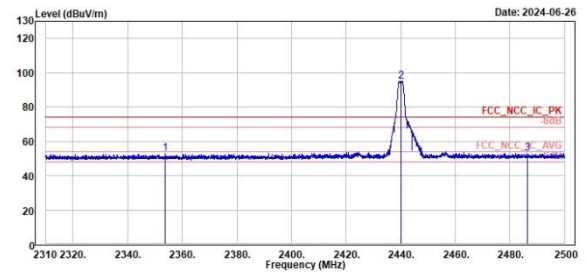
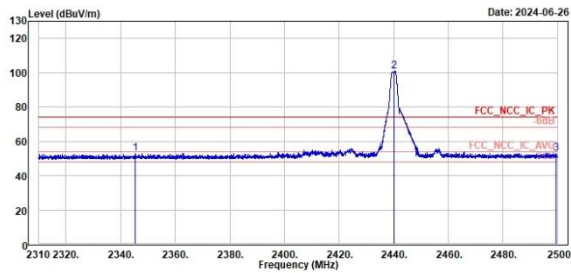

1	2	3								
Level	Level	Level								
Factor	Factor	Factor								
Line	Line	Line								
Limit	Limit	Limit								
Over	Over	Over								
Limit	Limit	Limit								
APos	APos	APos								
TPos	TPos	TPos								
Remark	Remark	Remark								
Pol/Phase	Pol/Phase	Pol/Phase								
Note	Note	Note								
2345.42	53.05	47.92	5.13	74.00	-20.95	326	206	Peak	Horizontal	
2440.00	100.62	95.16	5.46	74.00	26.62	326	206	Peak	Horizontal	
2499.32	53.09	47.56	5.53	74.00	-20.91	326	206	Peak	Horizontal	

1	2	3								
Level	Level	Level								
Factor	Factor	Factor								
Line	Line	Line								
Limit	Limit	Limit								
Over	Over	Over								
Limit	Limit	Limit								
APos	APos	APos								
TPos	TPos	TPos								
Remark	Remark	Remark								
Pol/Phase	Pol/Phase	Pol/Phase								
Note	Note	Note								
2353.74	52.99	47.83	5.16	74.00	-21.01	273	360	Peak	Vertical	
2440.00	94.89	89.43	5.46	74.00	20.89	273	360	Peak	Vertical	
2486.55	52.85	47.33	5.52	74.00	-21.15	273	360	Peak	Vertical	

BLE_2M

Middle Channel (Horizontal) Average

Middle Channel (Vertical) Average



TÜV Rheinland Taiwan Ltd.
No. 438-18, Sec 2, Fenfiao, Linkou Dist., New Taipei City 244, Taiwan(R.O.C.)
Tel: +886-2172-1000 Fax: +886-2172-1322

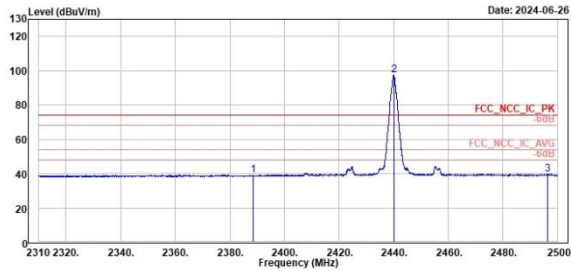

1	2	3
2388.39	2440.00	2496.31
39.03	97.59	39.51
33.78	92.13	33.98
5.25	5.46	5.53
54.00	54.00	54.00
-14.97	43.59	-14.49
326	326	326
206	206	206
Average	Average	Average
Horizontal	Horizontal	Horizontal



TÜV Rheinland Taiwan Ltd.
No. 438-18, Sec 2, Fenfiao, Linkou Dist., New Taipei City 244, Taiwan(R.O.C.)
Tel: +886-2172-1000 Fax: +886-2172-1322

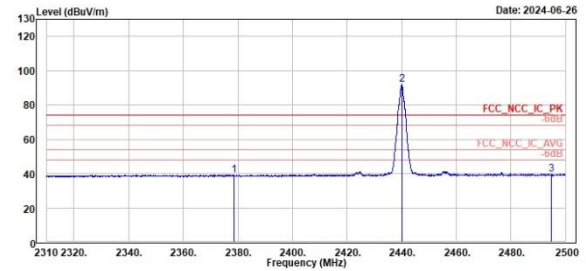

1	2	3
2378.67	2440.00	2494.79
39.16	91.92	39.53
33.93	86.46	34.01
5.23	5.46	5.52
54.00	54.00	54.00
-14.84	37.92	-14.47
273	273	273
360	360	360
Average	Average	Average
Vertical	Vertical	Vertical

BLE_2M

High Channel (Horizontal) Peak

High Channel (Vertical) Peak

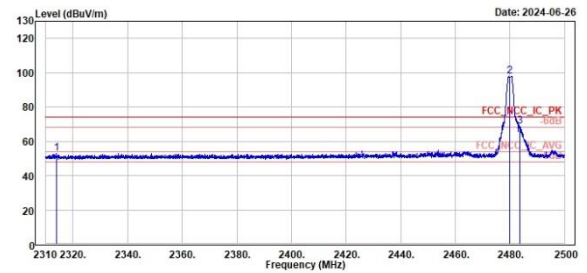
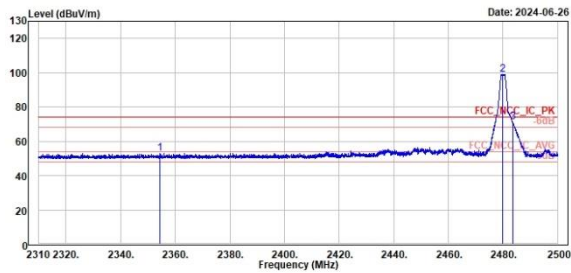
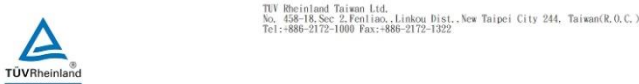

Freq	Level	Read	Limit	Over	APos	TPos	Remark	Pol/Phase	Note
MHz	dBuV/m	dBuV	dB/m	dBuV/m	dB	cm	deg		
1	2354.31	52.98	47.82	5.16	74.00	-21.02	131	202 Peak	Horizontal
2 *	2480.00	98.89	93.37	5.52	74.00	24.89	131	202 Peak	Horizontal
3 !	2483.51	71.12	65.60	5.52	74.00	-2.88	131	202 Peak	Horizontal

Freq	Level	Read	Limit	Over	APos	TPos	Remark	Pol/Phase	Note
MHz	dBuV/m	dBuV	dB/m	dBuV/m	dB	cm	deg		
1	2314.03	53.10	48.11	4.99	74.00	-20.90	116	0 Peak	Vertical
2 *	2480.00	97.96	92.44	5.52	74.00	23.96	116	0 Peak	Vertical
3 !	2483.74	68.09	63.37	5.52	74.00	-5.11	116	0 Peak	Vertical

BLE_2M

High Channel (Horizontal) Average

High Channel (Vertical) Average



TÜV Rheinland Taiwan Ltd.
No. 438-18, Sec 2, Fenfiao, Linkou Dist., New Taipei City 244, Taiwan(R.O.C.)
Tel: +886-2172-1000 Fax: +886-2172-1322

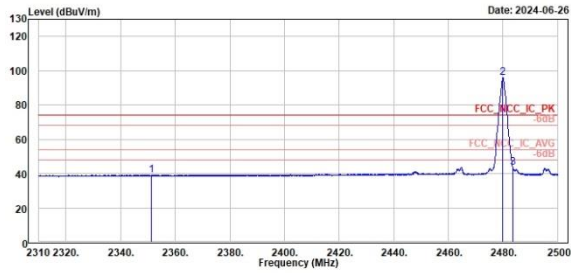

Freq	Level	Read Level	Factor	Limit Line	Over Limit	APos	TPos	Remark	Pol/Phase	Note
MHz	dBuV/m	dBuV	dB/m	dBuV/m	dB	cm	deg			
1	2351.38	39.26	34.11	5.15	54.00	-14.74	131	202 Average	Horizontal	
2 *	2480.00	95.94	90.42	5.52	54.00	41.94	131	202 Average	Horizontal	
3	2483.55	43.70	38.18	5.52	54.00	-10.30	131	202 Average	Horizontal	



TÜV Rheinland Taiwan Ltd.
No. 438-18, Sec 2, Fenfiao, Linkou Dist., New Taipei City 244, Taiwan(R.O.C.)
Tel: +886-2172-1000 Fax: +886-2172-1322

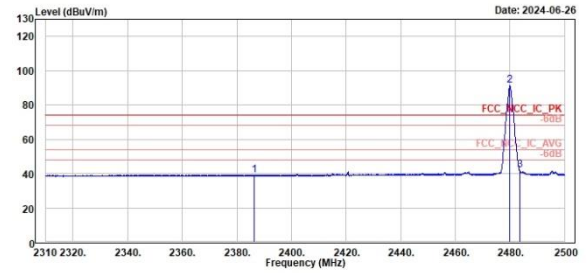

Freq	Level	Read Level	Factor	Limit Line	Over Limit	APos	TPos	Remark	Pol/Phase	Note
MHz	dBuV/m	dBuV	dB/m	dBuV/m	dB	cm	deg			
1	2386.34	39.21	33.97	5.24	54.00	-14.79	116	0 Average	Vertical	
2 *	2480.00	91.21	85.69	5.52	54.00	37.21	116	0 Average	Vertical	
3	2483.51	41.68	36.36	5.52	54.00	-12.12	116	0 Average	Vertical	

Spurious Emissions, Tx Mode, 9kHz ~ 30MHz

BLE_1M

High Channel (Open) 9kHz~150kHz

High Channel (Open) 150kHz~30MHz



TÜV Rheinland Taiwan Ltd.
No. 458-18, Sec 2, Fenliao, Linkou Dist., New Taipei City 244, Taiwan(R.O.C.)
Tel: +886-2172-1000 Fax: +886-2172-1322

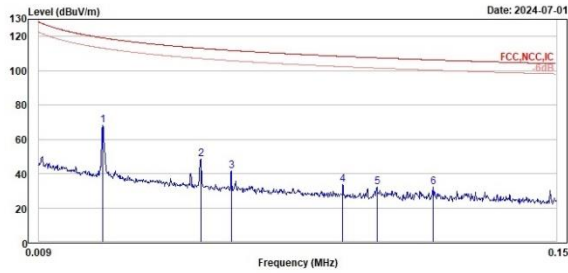

Peak	Freq (MHz)	Level (dBuV/m)	Read Level (dBuV)	Factor (dB/m)	Limit Line (dBuV/m)	Over Limit (dB)	APos (cm)	TPos (deg)	Remark	Pol/Phase	Note
1	0.03	68.04	48.49	19.55	119.13	-51.09	100	143	Peak	Open	
2	0.05	48.20	28.75	19.45	113.09	-64.89	100	261	Peak	Open	
3	0.06	41.60	22.31	19.29	111.82	-70.22	100	45	Peak	Open	
4	0.09	33.44	14.76	18.68	108.34	-74.90	100	145	Peak	Open	
5	0.10	31.96	13.44	18.52	107.50	-75.54	100	0	Peak	Open	
6	0.12	31.99	13.43	18.56	106.29	-74.30	100	150	Peak	Open	



TÜV Rheinland Taiwan Ltd.
No. 458-18, Sec 2, Fenliao, Linkou Dist., New Taipei City 244, Taiwan(R.O.C.)
Tel: +886-2172-1000 Fax: +886-2172-1322

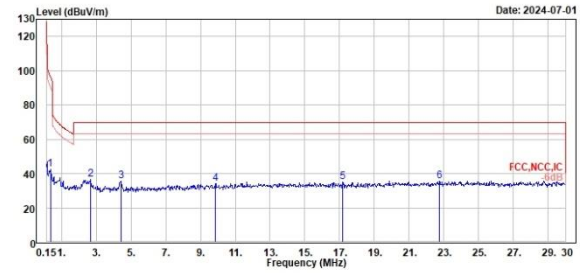

Peak	Freq (MHz)	Level (dBuV/m)	Read Level (dBuV)	Factor (dB/m)	Limit Line (dBuV/m)	Over Limit (dB)	APos (cm)	TPos (deg)	Remark	Pol/Phase	Note
1	0.36	42.51	23.48	19.03	96.50	-53.99	100	165	Peak	Open	
2	2.66	36.41	17.41	19.00	69.50	-33.09	100	99	Peak	Open	
3	4.45	35.69	16.33	19.36	69.50	-33.81	100	152	Peak	Open	
4	9.85	33.95	12.99	20.96	69.50	-35.55	100	4	Peak	Open	
5	17.16	35.06	13.20	21.86	69.50	-34.44	100	140	Peak	Open	
6	22.75	35.41	13.13	22.28	69.50	-34.09	100	345	Peak	Open	

Spurious Emissions, Tx Mode, 30MHz ~ 1GHz
BLE_1M
High Channel (Horizontal)
High Channel (Vertical)

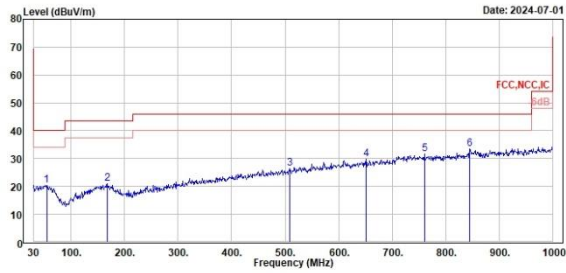
 TÜV Rheinland Taiwan Ltd.
 No. 438-18, Sec. 2, Penfiao, Linkou Dist., New Taipei City 244, Taiwan(R.O.C.)
 Tel: +886-2172-1000 Fax: +886-2172-1322

Peak	Freq (MHz)	Level (dBuV/m)	Read Level (dBuV)	Factor (dB/m)	Limit Line (dBuV/m)	Over Limit (dB)	APos (cm)	TPos (deg)	Remark	Pol/Phase	Note
1	54.25	20.45	27.34	-6.89	40.00	-19.55	200	147	Peak	Horizontal	
2	167.74	20.95	27.69	-6.74	43.50	-22.55	300	354	Peak	Horizontal	
3	509.18	26.57	28.36	-1.79	46.00	-19.43	200	139	Peak	Horizontal	
4	650.00	29.73	28.98	0.75	46.00	-16.27	100	360	Peak	Horizontal	
5	760.41	31.50	28.21	3.29	46.00	-14.50	100	113	Peak	Horizontal	
6	844.00	33.40	29.19	4.21	46.00	-12.60	300	85	Peak	Horizontal	

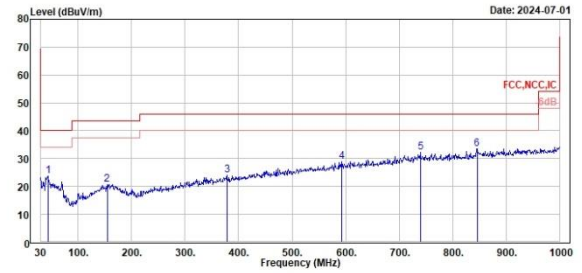
 TÜV Rheinland Taiwan Ltd.
 No. 438-18, Sec. 2, Penfiao, Linkou Dist., New Taipei City 244, Taiwan(R.O.C.)
 Tel: +886-2172-1000 Fax: +886-2172-1322

Peak	Freq (MHz)	Level (dBuV/m)	Read Level (dBuV)	Factor (dB/m)	Limit Line (dBuV/m)	Over Limit (dB)	APos (cm)	TPos (deg)	Remark	Pol/Phase	Note
1	43.50	23.07	31.28	-7.41	40.00	-16.13	100	190	Peak	Vertical	
2	154.16	20.65	27.59	-6.94	43.50	-22.85	100	360	Peak	Vertical	
3	378.23	24.06	28.45	-4.39	46.00	-21.94	137	360	Peak	Vertical	
4	592.60	28.06	28.83	0.03	46.00	-17.14	100	19	Peak	Vertical	
5	740.04	32.35	29.75	2.60	46.00	-13.65	300	338	Peak	Vertical	
6	845.77	33.53	29.30	4.23	46.00	-12.47	200	147	Peak	Vertical	

Spurious Emissions, Tx Mode, 1GHz ~ 26.5GHz

BLE_1M

Low Channel (Horizontal)

Low Channel (Vertical)



TÜV Rheinland Taiwan Ltd.
No. 438-18, Sec 2, Penfiao, Linkou Dist., New Taipei City 244, Taiwan(R.O.C.)
Tel: +886-2172-1000 Fax: +886-2172-1322

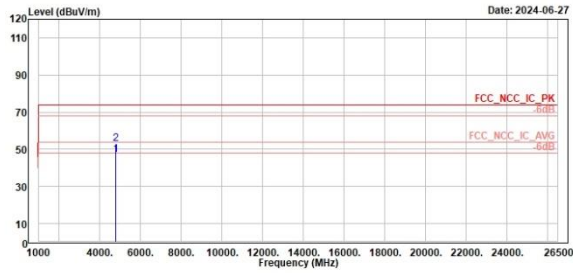

1	2
4894.00	4894.00
47.22	52.87
38.34	43.99
8.88	8.88
54.00	74.00
-6.78	-21.13
314	314
2	2
Average	Peak
Horizontal	Horizontal



TÜV Rheinland Taiwan Ltd.
No. 438-18, Sec 2, Penfiao, Linkou Dist., New Taipei City 244, Taiwan(R.O.C.)
Tel: +886-2172-1000 Fax: +886-2172-1322

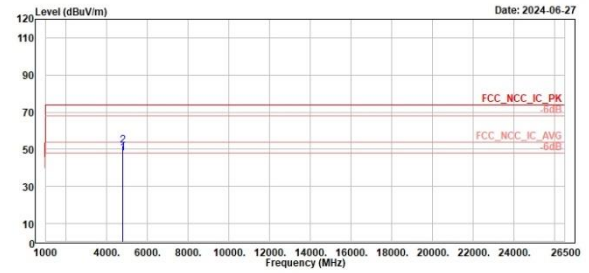

1	2
4894.00	4894.00
47.89	52.08
39.01	43.29
8.88	8.88
54.00	74.00
-6.11	-21.92
287	287
69	69
Average	Peak
Vertical	Vertical

BLE_1M

High Channel (Horizontal)

High Channel (Vertical)



TUV Rheinland Taiwan Ltd.
No. 438-18, Sec 2, Penfiao, Linkou Dist., New Taipei City 244, Taiwan(R.O.C.)
Tel: +886-2172-1000 Fax: +886-2172-1322

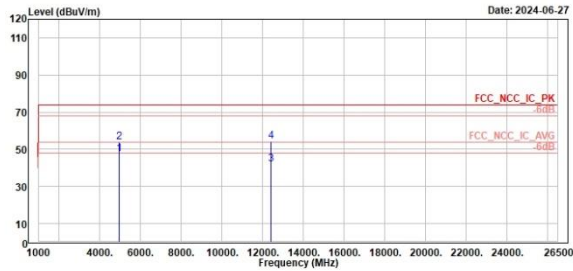

Line	Freq	Level	Read Level	Factor	Limit Line	Over Limit	APos	TPos	Remark	Pol/Phase	Note
	MHz	dBuV/m	dBuV	dB/m	dBuV/m	dB	cm	deg			
1	4968.00	47.55	38.28	9.27	54.00	-6.45	399	360	Average	Horizontal	
2	4968.00	53.63	44.36	9.27	74.00	-20.37	399	360	Peak	Horizontal	
3	12400.00	42.20	30.75	11.45	54.00	-11.89	100	194	Average	Horizontal	
4	12400.00	54.13	42.68	11.45	74.00	-19.87	100	194	Peak	Horizontal	



TUV Rheinland Taiwan Ltd.
No. 438-18, Sec 2, Penfiao, Linkou Dist., New Taipei City 244, Taiwan(R.O.C.)
Tel: +886-2172-1000 Fax: +886-2172-1322

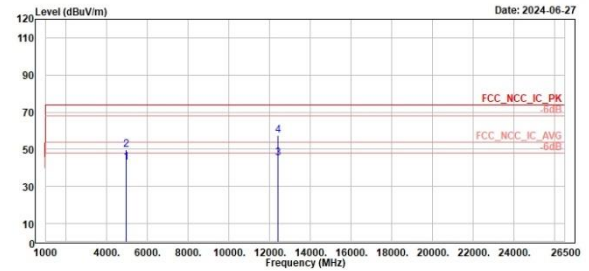

Line	Freq	Level	Read Level	Factor	Limit Line	Over Limit	APos	TPos	Remark	Pol/Phase	Note
	MHz	dBuV/m	dBuV	dB/m	dBuV/m	dB	cm	deg			
1	4968.00	43.00	33.73	9.27	54.00	-11.00	300	38	Average	Vertical	
2	4968.00	49.76	40.49	9.27	74.00	-24.24	300	38	Peak	Vertical	
3	12400.00	45.37	33.92	11.45	54.00	-8.63	100	291	Average	Vertical	
4	12400.00	57.61	46.16	11.45	74.00	-16.39	100	291	Peak	Vertical	

BLE_2M

Low Channel (Horizontal)

Low Channel (Vertical)



TUV Rheinland Taiwan Ltd.
No. 438-18, Sec 2, Fenliao, Linkou Dist., New Taipei City 244, Taiwan(R.O.C.)
Tel: +886-2172-1000 Fax: +886-2172-1322

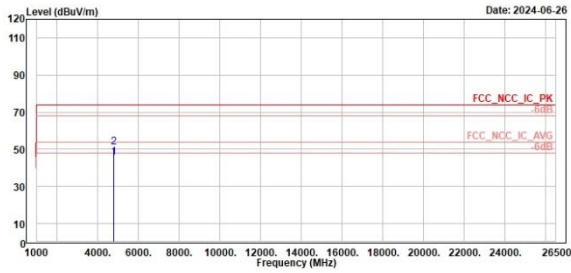

Freq	Level	Read Level	Factor	Limit	Over	APos	TPos	Remark	Pol/Phase	Note
MHz	dBuV/m	dBuV	dB/m	dBuV/m	dB	cm	deg			
1	4894.00	45.01	36.93	8.88	54.00	-8.19	374	360 Average	Horizontal	
2	4894.00	51.06	42.18	8.88	74.00	-22.94	374	360 Peak	Horizontal	



TUV Rheinland Taiwan Ltd.
No. 438-18, Sec 2, Fenliao, Linkou Dist., New Taipei City 244, Taiwan(R.O.C.)
Tel: +886-2172-1000 Fax: +886-2172-1322

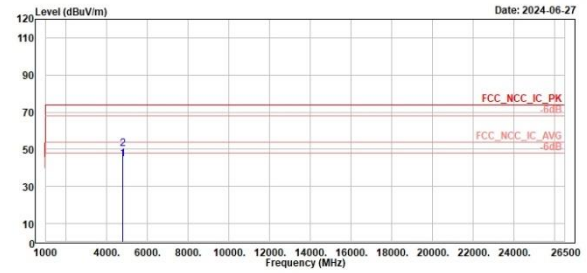

Freq	Level	Read Level	Factor	Limit	Over	APos	TPos	Remark	Pol/Phase	Note
MHz	dBuV/m	dBuV	dB/m	dBuV/m	dB	cm	deg			
1	4894.00	44.51	35.63	8.88	54.00	-9.49	354	220 Average	Vertical	
2	4894.00	50.16	41.28	8.88	74.00	-23.84	354	220 Peak	Vertical	

BLE_2M

Middle Channel (Horizontal)

Middle Channel (Vertical)



TÜV Rheinland Taiwan Ltd.
No. 438-18, Sec 2, Penfiao, Linkou Dist., New Taipei City 244, Taiwan(R.O.C.)
Tel: +886-2172-1000 Fax: +886-2172-1322

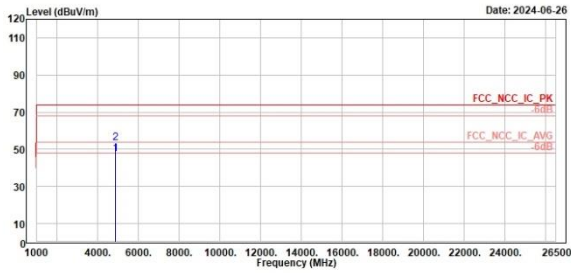

1	2
4880.00	4880.00
47.56	53.23
38.57	44.24
8.99	8.99
54.00	74.00
-6.44	-20.77
379	379
0	0
Average	Peak
Horizontal	Horizontal



TÜV Rheinland Taiwan Ltd.
No. 438-18, Sec 2, Penfiao, Linkou Dist., New Taipei City 244, Taiwan(R.O.C.)
Tel: +886-2172-1000 Fax: +886-2172-1322

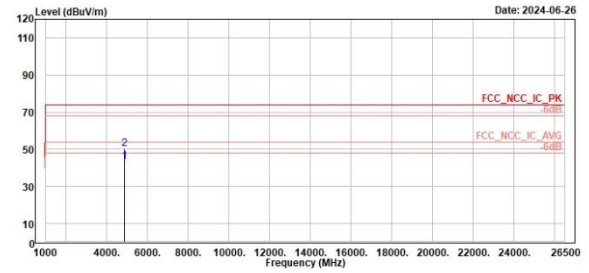

1	2
4880.00	4880.00
43.21	50.17
34.22	41.18
8.99	8.99
54.00	74.00
-10.79	-23.63
100	100
95	95
Average	Peak
Vertical	Vertical

BLE_2M

High Channel (Horizontal)

High Channel (Vertical)



TÜV Rheinland Taiwan Ltd.
No. 438-18, Sec 2, Fenfiao, Linkou Dist., New Taipei City 244, Taiwan(R.O.C.)
Tel: +886-2172-1000 Fax: +886-2172-1322

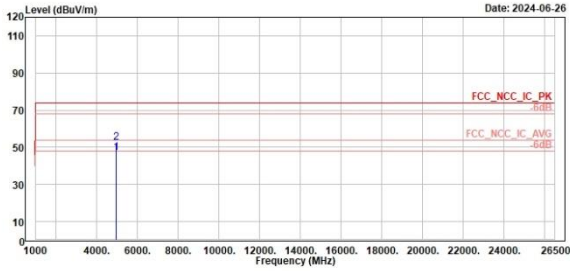

1	2
Level	Level
Factor	Factor
Line	Line
Limit	Limit
Over	Over
Limit	Limit
Apos	Apos
Tpos	Tpos
Remark	Remark
Pol/Phase	Pol/Phase
Note	Note
4968.00	4968.00
47.18	52.66
37.91	43.39
9.27	9.27
54.00	74.00
-6.82	-21.34
325	325
15	15
Average	Peak
Horizontal	Horizontal



TÜV Rheinland Taiwan Ltd.
No. 438-18, Sec 2, Fenfiao, Linkou Dist., New Taipei City 244, Taiwan(R.O.C.)
Tel: +886-2172-1000 Fax: +886-2172-1322

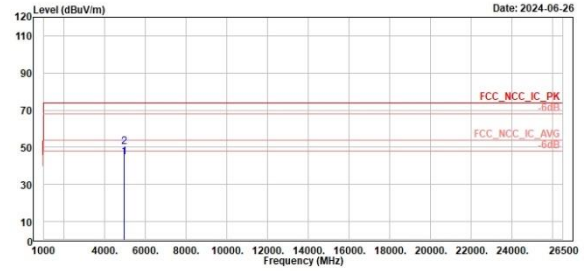

1	2
Level	Level
Factor	Factor
Line	Line
Limit	Limit
Over	Over
Limit	Limit
Apos	Apos
Tpos	Tpos
Remark	Remark
Pol/Phase	Pol/Phase
Note	Note
4968.00	4968.00
44.53	50.37
35.26	41.19
9.27	9.27
54.00	74.00
-9.47	-23.63
180	180
179	179
Average	Peak
Vertical	Vertical