

Partial FCC Test Report

Report No.: RF170927C20C-3

FCC ID: B94-8265D2WB

Test Model: TPN-Q200

Received Date: Oct. 27, 2017

Test Date: Jan. 11, 2018

Issued Date: Jan. 22, 2018

Applicant: HP Inc.

Address: 3390 East Harmony Road, Fort Collins, Colorado 80528, United States

Issued By: Bureau Veritas Consumer Products Services (H.K.) Ltd., Taoyuan Branch

Lab Address: No. 47-2, 14th Ling, Chia Pau Vil., Lin Kou Dist., New Taipei City, Taiwan (R.O.C)

Test Location (1): No. 19, Hwa Ya 2nd Rd, Wen Hwa Tsuen, Kwei Shan Hsiang, Taoyuan Hsien 333, Taiwan, R.O.C.

Test Location (2): B2F, No.215, Sec. 3, Beixin Rd. Xindian Dist. New Taipei City, R.O.C. Taiwan

**FCC Registration /
Designation Number:** 427177 / TW0011



This report is for your exclusive use. Any copying or replication of this report to or for any other person or entity, or use of our name or trademark, is permitted only with our prior written permission. This report sets forth our findings solely with respect to the test samples identified herein. The results set forth in this report are not indicative or representative of the quality or characteristics of the lot from which a test sample was taken or any similar or identical product unless specifically and expressly noted. Our report includes all of the tests requested by you and the results thereof based upon the information that you provided to us. You have 60 days from date of issuance of this report to notify us of any material error or omission caused by our negligence, provided, however, that such notice shall be in writing and shall specifically address the issue you wish to raise. A failure to raise such issue within the prescribed time shall constitute your unqualified acceptance of the completeness of this report, the tests conducted and the correctness of the report contents. Unless specific mention, the uncertainty of measurement has been explicitly taken into account to declare the compliance or non-compliance to the specification. The report must not be used by the client to claim product certification, approval, or endorsement by TAF or any government agencies.

Table of Contents

Release Control Record	3
1 Certificate of Conformity	4
2 Summary of Test Results.....	5
2.1 Measurement Uncertainty.....	5
2.2 Modification Record	5
3 General Information	6
3.1 General Description of EUT	6
3.2 Description of Test Modes.....	8
3.2.1 Test Mode Applicability and Tested Channel Detail.....	10
3.3 Description of Support Units	11
3.3.1 Configuration of System under Test	11
3.4 General Description of Applied Standards.....	11
4 Test Types and Results	12
4.1 Radiated Emission and Bandedge Measurement	12
4.1.1 Limits of Radiated Emission and Bandedge Measurement	12
4.1.2 Limits of Unwanted Emission Out of the Restricted Bands.....	13
4.1.3 Test Instruments	14
4.1.4 Test Procedures.....	15
4.1.5 Deviation from Test Standard	15
4.1.6 Test Set Up	16
4.1.7 EUT Operating Conditions.....	17
4.1.8 Test Results	18
4.2 Transmit Power Measurement.....	57
4.2.1 Limits of Transmit Power Measurement	57
4.2.2 Test Setup.....	57
4.2.3 Test Instruments	58
4.2.4 Test Procedure	58
4.2.5 Deviation from Test Standard	58
4.2.6 EUT Operating Conditions.....	58
4.2.7 Test Result.....	59
5 Pictures of Test Arrangements.....	61
Annex A- Radiated Out of Band Emision (OOBE) Measurement (For U-NII-3 band)	62
Appendix – Information on the Testing Laboratories	65

Release Control Record

Issue No.	Description	Date Issued
RF170927C20C-3	Original Release	Jan. 22, 2018

1 Certificate of Conformity

Product: Notebook Computer

Brand: HP

Test Model: TPN-Q200

Sample Status: Production Unit

Applicant: HP Inc.

Test Date: Jan. 11, 2018

Standards: 47 CFR FCC Part 15, Subpart E (Section 15.407)
ANSI C63.10:2013

The above equipment has been tested by **Bureau Veritas Consumer Products Services (H.K.) Ltd., Taoyuan Branch**, and found compliance with the requirement of the above standards. The test record, data evaluation & Equipment Under Test (EUT) configurations represented herein are true and accurate accounts of the measurements of the sample's RF characteristics under the conditions specified in this report.

Prepared by :  , **Date:** Jan. 22, 2018
Vera Huang / Specialist

Approved by :  , **Date:** Jan. 22, 2018
Dylan Chiou / Project Engineer

2 Summary of Test Results

47 CFR FCC Part 15, Subpart E (Section 15.407)			
FCC Clause	Test Item	Result	Remarks
15.407(b)(6)	AC Power Conducted Emissions	N/A	Refer to Note
15.407(b) (1/2/3/4(i/ii)/6)	Radiated Emissions & Band Edge Measurement	Pass	Meet the requirement of limit. Minimum passing margin is -1.2 dB at 5150 MHz.
15.407(a)(1/2/3)	Max Average Transmit Power	Pass	Meet the requirement of limit.
---	Occupied Bandwidth Measurement	N/A	Refer to Note
15.407(a)(1/2/3)	Peak Power Spectral Density	N/A	Refer to Note
15.407(e)	6 dB Bandwidth	N/A	Refer to Note
15.407(g)	Frequency Stability	N/A	Refer to Note
15.203	Antenna Requirement	N/A	Refer to Note

*For U-NII-3 band compliance with rule part 15.407(b)(4)(i), the OOB test plots were recorded in Annex A.

Note:

Only test items for Radiated Emissions and Transmit power tests were performed for this report. For other test data, please refer to Intel Report No.: 160321-02.TR01 / 160321-02.TR02 / 160321-02.TR03 for module (Brand: Intel, Model: 8265D2W).

2.1 Measurement Uncertainty

Where relevant, the following measurement uncertainty levels have been estimated for tests performed on the EUT as specified in CISPR 16-4-2:

Measurement	Frequency	Expanded Uncertainty (k=2) (±)
Conducted Emissions at mains ports	150 kHz ~ 30 MHz	2.44 dB
Radiated Emissions up to 1 GHz	30 MHz ~ 200 MHz	2.0153 dB
	200 MHz ~ 1000 MHz	2.0224 dB
Radiated Emissions above 1 GHz	1 GHz ~ 18 GHz	1.0121 dB
	18 GHz ~ 40 GHz	1.1508 dB

2.2 Modification Record

There were no modifications required for compliance.

3 General Information

3.1 General Description of EUT

Product	Notebook Computer
Brand	HP
Test Model	TPN-Q200
Status of EUT	Production Unit
Power Supply Rating	5 Vdc or 9 Vdc or 10 Vdc (adapter)
Modulation Type	256QAM, 64QAM, 16QAM, QPSK, BPSK
Modulation Technology	OFDM
Transfer Rate	802.11a: 54.0/ 48.0/ 36.0/ 24.0/ 18.0/ 12.0/ 9.0/ 6.0 Mbps 802.11n: up to 300 Mbps 802.11ac: up to 866.7 Mbps
Operating Frequency	5180 ~ 5240 MHz, 5260 ~ 5320 MHz, 5500 ~ 5700 MHz, 5745 ~ 5825 MHz
Number of Channel	5180 ~ 5240 MHz: 4 for 802.11a, 802.11n (HT20) 2 for 802.11n (HT40) 1 for 802.11ac (VHT80) 5260 ~ 5320 MHz: 4 for 802.11a, 802.11n (HT20) 2 for 802.11n (HT40) 1 for 802.11ac (VHT80) 5500 ~ 5700 MHz: 11 for 802.11a, 802.11n (HT20) 5 for 802.11n (HT40) 2 for 802.11ac (VHT80) 5745 ~ 5825 MHz: 5 for 802.11a, 802.11n (HT20) 2 for 802.11n (HT40) 1 for 802.11ac (VHT80)
Antenna Type	Refer to Note as below
Antenna Connector	N/A
Accessory Device	Refer to Note as below
Data Cable Supplied	N/A

Note:

1. The EUT incorporates a MIMO function. Physically, the EUT provides two completed transmitters and two receivers.

Modulation Mode	Tx Function
802.11a	2TX
802.11n (HT20)	2TX
802.11n (HT40)	2TX
802.11ac (VHT80)	2TX

* The modulation and bandwidth are similar for 802.11n mode for HT20 / HT40 and 802.11ac mode for VHT20 / VHT40, therefore investigated worst case to representative mode in test report. (Final test mode refer section 3.2.1)

2. The EUT contains following accessory devices.

Product	Brand	Model	Description
Adapter	hp	TPN-DA08	I/P: 100-240 Vac, 50/60 Hz, 1.8 A O/P: 5 Vdc, 3 A or 9 Vdc, 3 A or 10 Vdc, 5 A 1.76m shielded cable w/o core

3. The antenna information is listed as below.

Antenna Type	Mode	Manufacturer	Parts Number	Antenna Gain			
				WLAN 2.4 GHz / Bluetooth	WLAN 5.15~5.35 GHz	WLAN 5.47~5.725 GHz	WLAN 5.725~5.850 GHz
PIFA	NB Mode	WNC	WLAN Main Antenna: DQ6415GB200 WLAN Aux Antenna: DQ6415GB200	2.48	2.39	-0.16	-1.17
	Tablet Mode	WNC	WLAN Main Antenna: DQ6415GB200 WLAN Aux Antenna: DQ6415GB200	1.21	2.38	1.45	0.82

4. The above EUT information is declared by manufacturer and for more detailed features description, please refer to the manufacturer's specifications or user's manual.

3.2 Description of Test Modes

For 5180 ~ 5240 MHz

4 channels are provided for 802.11a, 802.11n (HT20):

Channel	Frequency (MHz)	Channel	Frequency (MHz)
36	5180	44	5220
40	5200	48	5240

2 channels are provided for 802.11n (HT40):

Channel	Frequency (MHz)	Channel	Frequency (MHz)
38	5190	46	5230

1 channel is provided for 802.11ac (VHT80):

Channel	Frequency (MHz)
42	5210

For 5260 ~ 5320 MHz

4 channels are provided for 802.11a, 802.11n (HT20):

Channel	Frequency (MHz)	Channel	Frequency (MHz)
52	5260	60	5300
56	5280	64	5320

2 channels are provided for 802.11n (HT40):

Channel	Frequency (MHz)	Channel	Frequency (MHz)
54	5270	62	5310

1 channel is provided for 802.11ac (VHT80):

Channel	Frequency (MHz)
58	5290

For 5500 ~ 5700 MHz

11 channels are provided for 802.11a, 802.11n (HT20):

Channel	Frequency (MHz)	Channel	Frequency (MHz)
100	5500	124	5620
104	5520	128	5640
108	5540	132	5660
112	5560	136	5680
116	5580	140	5700
120	5600		

5 channels are provided for 802.11n (HT40):

Channel	Frequency (MHz)	Channel	Frequency (MHz)
102	5510	126	5630
110	5550	134	5670
118	5590		

2 channels are provided for 802.11ac (VHT80):

Channel	Frequency (MHz)	Channel	Frequency (MHz)
106	5530	122	5610

For 5745 ~ 5825 MHz:

5 channels are provided for 802.11a, 802.11n (HT20):

Channel	Frequency (MHz)	Channel	Frequency (MHz)
149	5745	161	5805
153	5765	165	5825
157	5785		

2 channels are provided for 802.11n (HT40):

Channel	Frequency (MHz)	Channel	Frequency (MHz)
151	5755	159	5795

1 channel is provided for 802.11ac (VHT80):

Channel	Frequency (MHz)
155	5775

3.2.1 Test Mode Applicability and Tested Channel Detail

EUT Configure Mode	Applicable To		Description
	RE \geq 1G	RE $<$ 1G	
-	√	√	-

Where **RE \geq 1G**: Radiated Emission above 1 GHz **RE $<$ 1G**: Radiated Emission below 1 GHz

Note:

1. The EUT had been pre-tested on the positioned of each 3 axis. The worst case was found when positioned on Y-plane for 5180-5320 and Z-plane for 5500-5825.
2. "-" means no effect.

Radiated Emission Test (Above 1 GHz):

- Pre-Scan has been conducted to determine the worst-case mode from all possible combinations between available modulations, data rates and antenna ports (if EUT with antenna diversity architecture).
- Following channel(s) was (were) selected for the final test as listed below.

EUT Configure Mode	Frequency Band (MHz)	Mode	Available Channel	Tested Channel	Modulation Technology	Modulation Type	Data Rate (Mbps)	
-	5180-5240	802.11a	36 to 48	36, 44, 48	OFDM	BPSK	6.0	
-		802.11n (HT20)	36 to 48	36, 44, 48	OFDM	BPSK	MCS0	
-		802.11n (HT40)	38 to 46	38, 46	38, 46	OFDM	BPSK	MCS0
-		802.11ac (VHT80)	42	42	42	OFDM	BPSK	MCS0
-	5260-5320	802.11a	52 to 64	52, 60, 64	OFDM	BPSK	6.0	
-		802.11n (HT20)	52 to 64	52, 60, 64	OFDM	BPSK	MCS0	
-		802.11n (HT40)	54 to 62	54, 62	54, 62	OFDM	BPSK	MCS0
-		802.11ac (VHT80)	58	58	58	OFDM	BPSK	MCS0
-	5500-5700	802.11a	100 to 140	100, 116, 140	OFDM	BPSK	6.0	
-		802.11n (HT20)	100 to 140	100, 116, 140	OFDM	BPSK	MCS0	
-		802.11n (HT40)	102 to 134	102, 110, 134	102, 110, 134	OFDM	BPSK	MCS0
-		802.11ac (VHT80)	106 to 122	106, 122	106, 122	OFDM	BPSK	MCS0
-	5745-5825	802.11a	149 to 165	149, 157, 165	OFDM	BPSK	6.0	
-		802.11n (HT20)	149 to 165	149, 157, 165	OFDM	BPSK	MCS0	
-		802.11n (HT40)	151 to 159	151, 159	151, 159	OFDM	BPSK	MCS0
-		802.11ac (VHT80)	155	155	155	OFDM	BPSK	MCS0

Radiated Emission Test (Below 1 GHz):

- Pre-Scan has been conducted to determine the worst-case mode from all possible combinations between available modulations, data rates and antenna ports (if EUT with antenna diversity architecture).
- Following channel(s) was (were) selected for the final test as listed below.

EUT Configure Mode	Frequency Band (MHz)	Mode	Available Channel	Tested Channel	Modulation Technology	Modulation Type	Data Rate (Mbps)
-	5180-5240	802.11a	36 to 48	36	OFDM	BPSK	6.0

Test Condition:

Applicable To	Environmental Conditions	Input Power	Tested by
RE≥1G	25 deg. C, 65 % RH	120 Vac, 60 Hz	Karl Lee
RE<1G	25 deg. C, 65 % RH	120 Vac, 60 Hz	Karl Lee

3.3 Description of Support Units

The EUT has been tested as an independent unit together with other necessary accessories or support units.

3.3.1 Configuration of System under Test

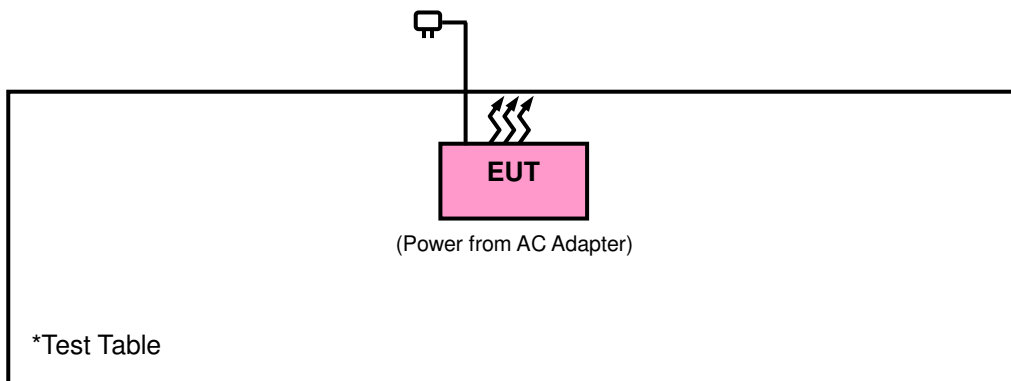

3.4 General Description of Applied Standards

The EUT is a RF Product. According to the specifications of the manufacturer, it must comply with the requirements of the following standards:

FCC Part 15, Subpart E (15.407)

789033 D02 General UNII Test Procedures New Rules v02r01

644545 D01 Guidance for IEEE 802 11ac v01r02

662911 D01 Multiple Transmitter Output v02r01

ANSI C63.10-2013

All test items have been performed and recorded as per the above standards.

Note: The EUT has been verified to comply with the requirements of FCC Part 15, Subpart B, Class B (DoC). The test report has been issued separately.

4 Test Types and Results

4.1 Radiated Emission and Bandedge Measurement

4.1.1 Limits of Radiated Emission and Bandedge Measurement

Radiated emissions which fall in the restricted bands must comply with the radiated emission limits specified as below table. Other emissions shall be at least 20 dB below the highest level of the desired power:

Frequencies (MHz)	Field Strength (microvolts/meter)	Measurement Distance (meters)
0.009 ~ 0.490	2400/F (kHz)	300
0.490 ~ 1.705	24000/F (kHz)	30
1.705 ~ 30.0	30	30
30 ~ 88	100	3
88 ~ 216	150	3
216 ~ 960	200	3
Above 960	500	3

Note:

1. The lower limit shall apply at the transition frequencies.
2. Emission level (dBuV/m) = 20 log Emission level (uV/m).
3. For frequencies above 1000 MHz, the field strength limits are based on average detector, however, the peak field strength of any emission shall not exceed the maximum permitted average limits, specified above by more than 20 dB under any condition of modulation.

4.1.2 Limits of Unwanted Emission Out of the Restricted Bands

Applicable To		Limit	
789033 D02 General UNII Test Procedures New Rules v02r01		Field Strength at 3 m	
		PK: 74 (dBμV/m)	AV: 54 (dBμV/m)
Frequency Band	Applicable To	EIRP Limit	Equivalent Field Strength at 3 m
5150~5250 MHz	15.407(b)(1)	PK: -27 (dBm/MHz)	PK: 68.2 (dBμV/m)
5250~5350 MHz	15.407(b)(2)		
5470~5725 MHz	15.407(b)(3)		
5725~5850 MHz	15.407(b)(4)(i)	PK:-27 (dBm/MHz) ^{*1} PK:10 (dBm/MHz) ^{*2} PK:15.6 (dBm/MHz) ^{*3} PK:27 (dBm/MHz) ^{*4}	PK: 68.2 (dBμV/m) ^{*1} PK:105.2 (dBμV/m) ^{*2} PK: 110.8 (dBμV/m) ^{*3} PK:122.2 (dBμV/m) ^{*4}
	15.407(b)(4)(ii)	Emission limits in section 15.247(d)	
^{*1} beyond 75 MHz or more above of the band edge. ^{*2} below the band edge increasing linearly to 10 dBm/MHz at 25 MHz above. ^{*3} below the band edge increasing linearly to a level of 15.6 dBm/MHz at 5 MHz above. ^{*4} from 5 MHz above or below the band edge increasing linearly to a level of 27 dBm/MHz at the band edge.			

Note:

The following formula is used to convert the equipment isotropic radiated power (eirp) to field strength:

$$E = \frac{1000000\sqrt{30P}}{3} \mu\text{V/m, where } P \text{ is the eirp (Watts).}$$

4.1.3 Test Instruments

Description & Manufacturer	Model No.	Serial No.	Date of Calibration	Due Date of Calibration
Test Receiver Agilent Technologies	N9038A	MY52260177	Jul. 05, 2017	Jul. 04, 2018
Spectrum Analyzer ROHDE & SCHWARZ	FSU43	101261	Jan. 11, 2018	Jan. 10, 2019
BILOG Antenna SCHWARZBECK	VULB9168	9168-472	Dec. 06, 2017	Dec. 05, 2018
HORN Antenna ETS-Lindgren	3117	00143293	Jun. 26, 2017	Jun. 25, 2018
HORN Antenna SCHWARZBECK	BBHA 9170	9170-480	Dec. 01, 2017	Nov. 30, 2018
Fixed Attenuator Mini-Circuits	BW-N10W5+	NA	Jul. 07, 2017	Jul. 06, 2018
Bluetooth Tester	CBT	100980	Jun. 28, 2017	Jun. 27, 2019
Loop Antenna	EM-6879	269	Aug. 11, 2017	Aug. 10, 2018
Preamplifier Agilent	310N	187226	Jun. 23, 2017	Jun. 22, 2018
Preamplifier Agilent	83017A	MY39501357	Jun. 23, 2017	Jun. 22, 2018
Power Meter Anritsu	ML2495A	1012010	Aug. 15, 2017	Aug. 14, 2018
Power Sensor Anritsu	MA2411B	1315050	Aug. 15, 2017	Aug. 14, 2018
RF signal cable ETS-LINDGREN	5D-FB	Cable-CH1-01(R FC-SMS-100-SM S-120+RFC-SMS -100-SMS-400)	Jun. 26, 2017	Jun. 25, 2018
RF signal cable ETS-LINDGREN	8D-FB	Cable-CH1-02(R FC-SMS-100-SM S-24)	Jun. 26, 2017	Jun. 25, 2018
Software BV ADT	E3 8.130425b	NA	NA	NA
Antenna Tower MF	NA	NA	NA	NA
Turn Table MF	NA	NA	NA	NA
Antenna Tower & Turn Table Controller MF	MF-7802	NA	NA	NA

- Note: 1. The calibration interval of the above test instruments is 12 months and the calibrations are traceable to NML/ROC and NIST/USA.
2. The test was performed in HsinTien Chamber 1.
3. The horn antenna and preamplifier (model: 83017A) are used only for the measurement of emission frequency above 1 GHz if tested.
4. The IC Site Registration No. is IC7450I-1.

4.1.4 Test Procedures

- a. The EUT was placed on the top of a rotating table 0.8 meters (for below 1 GHz) / 1.5 meters (for above 1 GHz) above the ground at 3 meter chamber room for test. The table was rotated 360 degrees to determine the position of the highest radiation.
- b. The EUT was set 3 meters away from the interference-receiving antenna, which was mounted on the top of a variable-height antenna tower.
- c. The height of antenna is varied from one meter to four meters above the ground to determine the maximum value of the field strength. Both horizontal and vertical polarizations of the antenna are set to make the measurement.
- d. For each suspected emission, the EUT was arranged to its worst case and then the antenna was tuned to heights from 1 meter to 4 meters and the rotatable table was turned from 0 degrees to 360 degrees to find the maximum reading.
- e. The test-receiver system was set to quasi-peak detect function and specified bandwidth with maximum hold mode when the test frequency is below 1 GHz.
- f. The test-receiver system was set to peak and average detected function and specified bandwidth with maximum hold mode when the test frequency is above 1 GHz. If the peak reading value also meets average limit, measurement with the average detector is unnecessary.

Note:

1. The resolution bandwidth and video bandwidth of test receiver/spectrum analyzer is 120 kHz & 360 kHz for Quasi-peak detection (QP) at frequency below 1 GHz.
2. The resolution bandwidth of test receiver/spectrum analyzer is 1 MHz and the video bandwidth is 3 MHz for Peak detection (PK) at frequency above 1 GHz.
3. The resolution bandwidth of test receiver/spectrum analyzer is 1 MHz and the video bandwidth is 1/T for Average (Duty cycle < 98 %) detection at frequency above 1 GHz.
4. The resolution bandwidth of test receiver/spectrum analyzer is 1 MHz and the video bandwidth is 10 Hz (Duty cycle ≥ 98 %) for Average detection (AV) at frequency above 1 GHz.
5. All modes of operation were investigated and the worst-case emissions are reported.

4.1.5 Deviation from Test Standard

No deviation.

4.1.6 Test Set Up

<Radiated emission below 30 MHz>

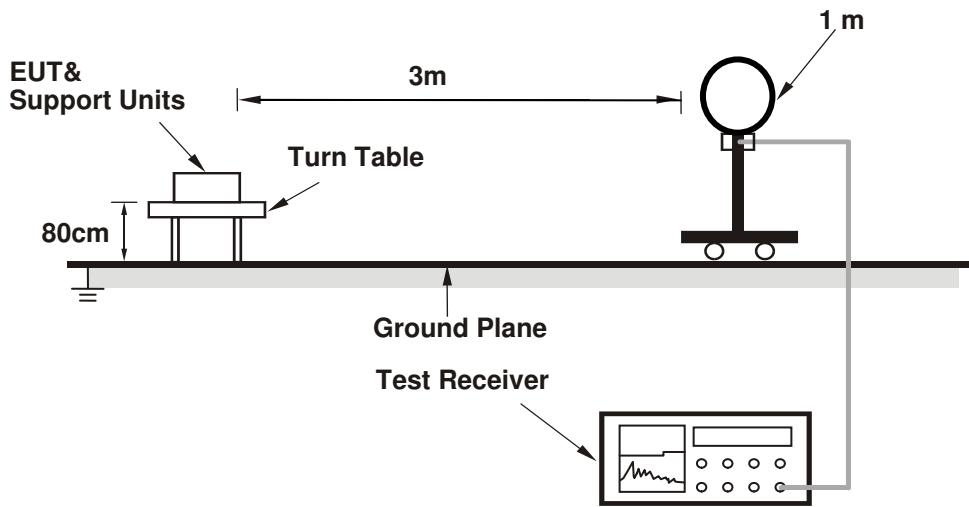

<Frequency Range below 1 GHz>

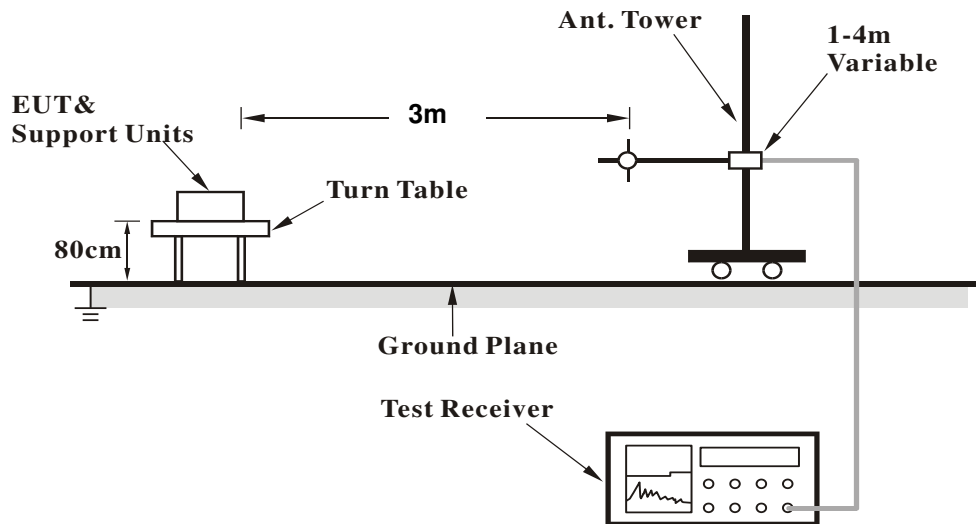

<Frequency Range above 1 GHz>

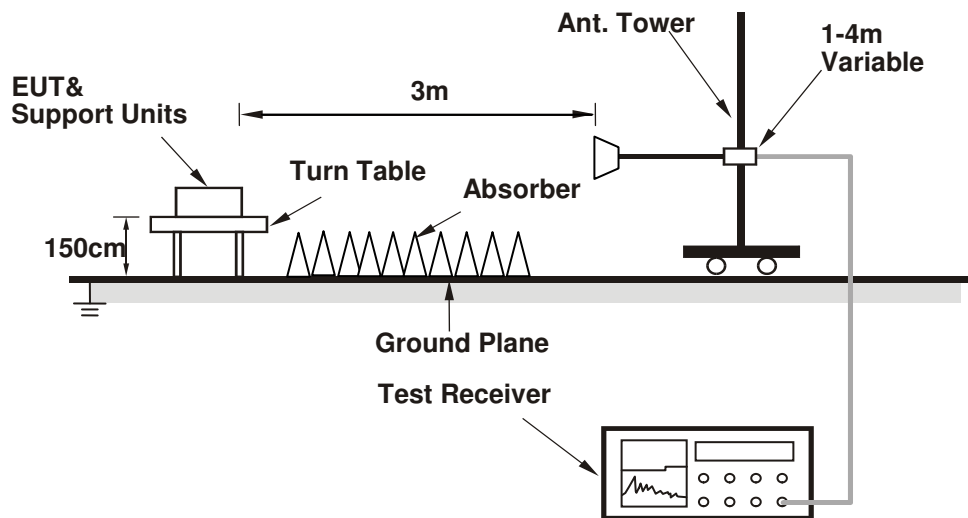

For the actual test configuration, please refer to the attached file (Test Setup Photo).

4.1.7 EUT Operating Conditions

- a. Placed the EUT on a testing table.
- b. Use the software to control the EUT under transmission condition continuously at specific channel frequency.

4.1.8 Test Results
Above 1 GHz Data :
802.11a

EUT Test Condition		Measurement Detail	
Channel	Channel 36	Frequency Range	1 GHz ~ 40 GHz
Input Power	120 Vac, 60 Hz	Detector Function	Peak (PK) Average (AV)
Environmental Conditions	25 deg. C, 65 % RH	Tested By	Karl Lee

Antenna Polarity & Test Distance: Horizontal at 3 m										
Frequency (MHz)	Emission Level (dBuV/m)	Read Level (dBuV)	Limit (dBuV/m)	Margin (dB)	Antenna Factor (dB/m)	Cable Loss (dB)	Preamp Factor (dB)	Antenna Height (cm)	Table Angle (Degree)	Remark
5149.7	47.56	39.31	54	-6.44	34.12	8.13	34	172	138	Average
5149.7	58.8	50.55	74	-15.2	34.12	8.13	34	172	138	Peak
5180	98.05	89.74			34.15	8.16	34	172	138	Average
5180	105.25	96.94			34.15	8.16	34	172	138	Peak
10360	55.44	41.14	74	-18.56	37.12	12.3	35.12	187	162	Peak

Antenna Polarity & Test Distance: Vertical at 3 m										
Frequency (MHz)	Emission Level (dBuV/m)	Read Level (dBuV)	Limit (dBuV/m)	Margin (dB)	Antenna Factor (dB/m)	Cable Loss (dB)	Preamp Factor (dB)	Antenna Height (cm)	Table Angle (Degree)	Remark
5150	52.8	44.55	54	-1.2	34.12	8.13	34	162	22	Average
5150	66.09	57.84	74	-7.91	34.12	8.13	34	162	22	Peak
5180	101.22	92.91			34.15	8.16	34	162	22	Average
5180	108.59	100.28			34.15	8.16	34	162	22	Peak
10360	55.81	41.51	74	-18.19	37.12	12.3	35.12	139	265	Peak

Remarks:

- Emission Level = Read Level + Antenna Factor + Cable Loss - Preamp Factor
 Margin value = Emission level – Limit value
- 5180 MHz: Fundamental Frequency

EUT Test Condition		Measurement Detail	
Channel	Channel 44	Frequency Range	1 GHz ~ 40 GHz
Input Power	120 Vac, 60 Hz	Detector Function	Peak (PK) Average (AV)
Environmental Conditions	25 deg. C, 65 % RH	Tested By	Karl Lee

Antenna Polarity & Test Distance: Horizontal at 3 m										
Frequency (MHz)	Emission Level (dBuV/m)	Read Level (dBuV)	Limit (dBuV/m)	Margin (dB)	Antenna Factor (dB/m)	Cable Loss (dB)	Preamp Factor (dB)	Antenna Height (cm)	Table Angle (Degree)	Remark
5150	43.82	35.57	54	-10.18	34.12	8.13	34	100	34	Average
5150	53.9	45.65	74	-20.1	34.12	8.13	34	100	34	Peak
5220	98.92	90.53			34.17	8.22	34	100	34	Average
5220	106.67	98.28			34.17	8.22	34	100	34	Peak
5378.93	43.41	34.73	54	-10.59	34.31	8.41	34.04	100	34	Average
5378.93	54.05	45.37	74	-19.95	34.31	8.41	34.04	100	34	Peak

Antenna Polarity & Test Distance: Vertical at 3 m										
Frequency (MHz)	Emission Level (dBuV/m)	Read Level (dBuV)	Limit (dBuV/m)	Margin (dB)	Antenna Factor (dB/m)	Cable Loss (dB)	Preamp Factor (dB)	Antenna Height (cm)	Table Angle (Degree)	Remark
5111.75	42.79	34.59	54	-11.21	34.09	8.1	33.99	103	55	Average
5111.75	54.39	46.19	74	-19.61	34.09	8.1	33.99	103	55	Peak
5220	94.52	86.13			34.17	8.22	34	103	55	Average
5220	102.05	93.66			34.17	8.22	34	103	55	Peak
5374.64	42.82	34.16	54	-11.18	34.29	8.41	34.04	103	55	Average
5374.64	53.84	45.18	74	-20.16	34.29	8.41	34.04	103	55	Peak

Remarks:

- Emission Level = Read Level + Antenna Factor + Cable Loss - Preamp Factor
Margin value = Emission level – Limit value
- 5220 MHz: Fundamental Frequency

EUT Test Condition		Measurement Detail	
Channel	Channel 48	Frequency Range	1 GHz ~ 40 GHz
Input Power	120 Vac, 60 Hz	Detector Function	Peak (PK) Average (AV)
Environmental Conditions	25 deg. C, 65 % RH	Tested By	Karl Lee

Antenna Polarity & Test Distance: Horizontal at 3 m										
Frequency (MHz)	Emission Level (dBuV/m)	Read Level (dBuV)	Limit (dBuV/m)	Margin (dB)	Antenna Factor (dB/m)	Cable Loss (dB)	Preamp Factor (dB)	Antenna Height (cm)	Table Angle (Degree)	Remark
5240	98.98	90.54			34.19	8.26	34.01	100	34	Average
5240	106.34	97.9			34.19	8.26	34.01	100	34	Peak
5402.14	43.19	34.47	54	-10.81	34.32	8.44	34.04	100	34	Average
5402.14	53.8	45.08	74	-20.2	34.32	8.44	34.04	100	34	Peak
*10480	54.31	39.8	68.2	-13.89	37.19	12.53	35.21	164	203	Peak

Antenna Polarity & Test Distance: Vertical at 3 m										
Frequency (MHz)	Emission Level (dBuV/m)	Read Level (dBuV)	Limit (dBuV/m)	Margin (dB)	Antenna Factor (dB/m)	Cable Loss (dB)	Preamp Factor (dB)	Antenna Height (cm)	Table Angle (Degree)	Remark
5240	94.97	86.53			34.19	8.26	34.01	103	55	Average
5240	102.07	93.63			34.19	8.26	34.01	103	55	Peak
5387.62	42.81	34.13	54	-11.19	34.31	8.41	34.04	103	55	Average
5387.62	53.81	45.13	74	-20.19	34.31	8.41	34.04	103	55	Peak
*10480	54.89	40.38	68.2	-13.31	37.19	12.53	35.21	186	215	Peak

Remarks:

- Emission Level = Read Level + Antenna Factor + Cable Loss - Preamp Factor
Margin value = Emission level – Limit value
- 5240 MHz: Fundamental Frequency
- *: Out of Restricted Band

EUT Test Condition		Measurement Detail	
Channel	Channel 52	Frequency Range	1 GHz ~ 40 GHz
Input Power	120 Vac, 60 Hz	Detector Function	Peak (PK) Average (AV)
Environmental Conditions	25 deg. C, 65 % RH	Tested By	Karl Lee

Antenna Polarity & Test Distance: Horizontal at 3 m										
Frequency (MHz)	Emission Level (dBuV/m)	Read Level (dBuV)	Limit (dBuV/m)	Margin (dB)	Antenna Factor (dB/m)	Cable Loss (dB)	Preamp Factor (dB)	Antenna Height (cm)	Table Angle (Degree)	Remark
5108	42.39	34.19	54	-11.61	34.09	8.1	33.99	111	60	Average
5108	53	44.8	74	-21	34.09	8.1	33.99	111	60	Peak
5260	98.94	90.48			34.21	8.26	34.01	111	60	Average
5260	106.96	98.5			34.21	8.26	34.01	111	60	Peak
*10520	56.51	41.92	68.2	-11.69	37.21	12.61	35.23	195	151	Peak

Antenna Polarity & Test Distance: Vertical at 3 m										
Frequency (MHz)	Emission Level (dBuV/m)	Read Level (dBuV)	Limit (dBuV/m)	Margin (dB)	Antenna Factor (dB/m)	Cable Loss (dB)	Preamp Factor (dB)	Antenna Height (cm)	Table Angle (Degree)	Remark
5133.2	42.14	33.89	54	-11.86	34.11	8.13	33.99	109	62	Average
5133.2	53.59	45.34	74	-20.41	34.11	8.13	33.99	109	62	Peak
5260	97.44	88.98			34.21	8.26	34.01	109	62	Average
5260	104.64	96.18			34.21	8.26	34.01	109	62	Peak
*10520	54.84	40.25	68.2	-13.36	37.21	12.61	35.23	131	176	Peak

Remarks:

- Emission Level = Read Level + Antenna Factor + Cable Loss - Preamp Factor
Margin value = Emission level – Limit value
- 5260 MHz: Fundamental Frequency
- *: Out of Restricted Band

EUT Test Condition		Measurement Detail	
Channel	Channel 60	Frequency Range	1 GHz ~ 40 GHz
Input Power	120 Vac, 60 Hz	Detector Function	Peak (PK) Average (AV)
Environmental Conditions	25 deg. C, 65 % RH	Tested By	Karl Lee

Antenna Polarity & Test Distance: Horizontal at 3 m										
Frequency (MHz)	Emission Level (dBuV/m)	Read Level (dBuV)	Limit (dBuV/m)	Margin (dB)	Antenna Factor (dB/m)	Cable Loss (dB)	Preamp Factor (dB)	Antenna Height (cm)	Table Angle (Degree)	Remark
5144.9	42.53	34.28	54	-11.47	34.12	8.13	34	111	60	Average
5144.9	53.42	45.17	74	-20.58	34.12	8.13	34	111	60	Peak
5300	99.23	90.69			34.24	8.32	34.02	111	60	Average
5300	106.82	98.28			34.24	8.32	34.02	111	60	Peak
5350.66	45.82	37.19	54	-8.18	34.28	8.38	34.03	111	60	Average
5350.66	54.71	46.08	74	-19.29	34.28	8.38	34.03	111	60	Peak

Antenna Polarity & Test Distance: Vertical at 3 m										
Frequency (MHz)	Emission Level (dBuV/m)	Read Level (dBuV)	Limit (dBuV/m)	Margin (dB)	Antenna Factor (dB/m)	Cable Loss (dB)	Preamp Factor (dB)	Antenna Height (cm)	Table Angle (Degree)	Remark
5136.8	42.31	34.06	54	-11.69	34.11	8.13	33.99	109	62	Average
5136.8	52.81	44.56	74	-21.19	34.11	8.13	33.99	109	62	Peak
5300	97.57	89.03			34.24	8.32	34.02	109	62	Average
5300	104.73	96.19			34.24	8.32	34.02	109	62	Peak
5350.66	44.31	35.68	54	-9.69	34.28	8.38	34.03	109	62	Average
5350.66	54.24	45.61	74	-19.76	34.28	8.38	34.03	109	62	Peak

Remarks:

- Emission Level = Read Level + Antenna Factor + Cable Loss - Preamp Factor
Margin value = Emission level – Limit value
- 5300 MHz: Fundamental Frequency

EUT Test Condition		Measurement Detail	
Channel	Channel 64	Frequency Range	1 GHz ~ 40 GHz
Input Power	120 Vac, 60 Hz	Detector Function	Peak (PK) Average (AV)
Environmental Conditions	25 deg. C, 65 % RH	Tested By	Karl Lee

Antenna Polarity & Test Distance: Horizontal at 3 m										
Frequency (MHz)	Emission Level (dBuV/m)	Read Level (dBuV)	Limit (dBuV/m)	Margin (dB)	Antenna Factor (dB/m)	Cable Loss (dB)	Preamp Factor (dB)	Antenna Height (cm)	Table Angle (Degree)	Remark
5320	100.39	91.81			34.25	8.35	34.02	113	22	Average
5320	107.26	98.68			34.25	8.35	34.02	113	22	Peak
5350.11	48.35	39.72	54	-5.65	34.28	8.38	34.03	113	22	Average
5350.11	58.56	49.93	74	-15.44	34.28	8.38	34.03	113	22	Peak
10640	48.16	33.43	54	-5.84	37.31	12.71	35.29	160	175	Average
10640	57.02	42.29	74	-16.98	37.31	12.71	35.29	160	175	Peak

Antenna Polarity & Test Distance: Vertical at 3 m										
Frequency (MHz)	Emission Level (dBuV/m)	Read Level (dBuV)	Limit (dBuV/m)	Margin (dB)	Antenna Factor (dB/m)	Cable Loss (dB)	Preamp Factor (dB)	Antenna Height (cm)	Table Angle (Degree)	Remark
5320	96.88	88.3			34.25	8.35	34.02	172	138	Average
5320	104.54	95.96			34.25	8.35	34.02	172	138	Peak
5351.21	44.05	35.42	54	-9.95	34.28	8.38	34.03	172	138	Average
5351.21	54.04	45.41	74	-19.96	34.28	8.38	34.03	172	138	Peak
10640	48.2	33.47	54	-5.8	37.31	12.71	35.29	135	283	Average
10640	57.5	42.77	74	-16.5	37.31	12.71	35.29	135	283	Peak

Remarks:

- Emission Level = Read Level + Antenna Factor + Cable Loss - Preamp Factor
Margin value = Emission level – Limit value
- 5320 MHz: Fundamental Frequency

EUT Test Condition		Measurement Detail	
Channel	Channel 100	Frequency Range	1 GHz ~ 40 GHz
Input Power	120 Vac, 60 Hz	Detector Function	Peak (PK) Average (AV)
Environmental Conditions	25 deg. C, 65 % RH	Tested By	Karl Lee

Antenna Polarity & Test Distance: Horizontal at 3 m										
Frequency (MHz)	Emission Level (dBuV/m)	Read Level (dBuV)	Limit (dBuV/m)	Margin (dB)	Antenna Factor (dB/m)	Cable Loss (dB)	Preamp Factor (dB)	Antenna Height (cm)	Table Angle (Degree)	Remark
5459.44	46.28	37.46	54	-7.72	34.36	8.51	34.05	121	303	Average
5459.44	57.54	48.72	74	-16.46	34.36	8.51	34.05	121	303	Peak
*5470.64	61.9	53.07	68.2	-6.3	34.37	8.51	34.05	121	303	Peak
5500	95.45	86.53			34.4	8.57	34.05	121	303	Average
5500	102.07	93.15			34.4	8.57	34.05	121	303	Peak
11000	47.92	32.84	54	-6.08	37.6	12.96	35.48	164	205	Average
11000	57.99	42.91	74	-16.01	37.6	12.96	35.48	164	205	Peak
Antenna Polarity & Test Distance: Vertical at 3 m										
Frequency (MHz)	Emission Level (dBuV/m)	Read Level (dBuV)	Limit (dBuV/m)	Margin (dB)	Antenna Factor (dB/m)	Cable Loss (dB)	Preamp Factor (dB)	Antenna Height (cm)	Table Angle (Degree)	Remark
5459.92	50.39	41.57	54	-3.61	34.36	8.51	34.05	255	26	Average
5459.92	61.54	52.72	74	-12.46	34.36	8.51	34.05	255	26	Peak
*5470.32	66.46	57.63	68.2	-1.74	34.37	8.51	34.05	255	26	Peak
5500	101.15	92.23			34.4	8.57	34.05	255	26	Average
5500	108.63	99.71			34.4	8.57	34.05	255	26	Peak
11000	48.11	33.03	54	-5.89	37.6	12.96	35.48	132	95	Average
11000	58.2	43.12	74	-15.8	37.6	12.96	35.48	132	95	Peak

Remarks:

- Emission Level = Read Level + Antenna Factor + Cable Loss - Preamp Factor
Margin value = Emission level – Limit value
- 5500 MHz: Fundamental Frequency
- *: Out of Restricted Band

EUT Test Condition		Measurement Detail	
Channel	Channel 116	Frequency Range	1 GHz ~ 40 GHz
Input Power	120 Vac, 60 Hz	Detector Function	Peak (PK) Average (AV)
Environmental Conditions	25 deg. C, 65 % RH	Tested By	Karl Lee

Antenna Polarity & Test Distance: Horizontal at 3 m										
Frequency (MHz)	Emission Level (dBuV/m)	Read Level (dBuV)	Limit (dBuV/m)	Margin (dB)	Antenna Factor (dB/m)	Cable Loss (dB)	Preamp Factor (dB)	Antenna Height (cm)	Table Angle (Degree)	Remark
5446.16	42.87	34.04	54	-11.13	34.36	8.51	34.04	100	300	Average
5446.16	53.72	44.89	74	-20.28	34.36	8.51	34.04	100	300	Peak
*5468.72	52.28	43.45	68.2	-15.92	34.37	8.51	34.05	100	300	Peak
5580	91.47	82.48			34.47	8.6	34.08	100	300	Average
5580	99.64	90.65			34.47	8.6	34.08	100	300	Peak
*5725.32	53.17	44.01	68.2	-15.03	34.62	8.65	34.11	100	300	Peak

Antenna Polarity & Test Distance: Vertical at 3 m										
Frequency (MHz)	Emission Level (dBuV/m)	Read Level (dBuV)	Limit (dBuV/m)	Margin (dB)	Antenna Factor (dB/m)	Cable Loss (dB)	Preamp Factor (dB)	Antenna Height (cm)	Table Angle (Degree)	Remark
5458.48	44.13	35.31	54	-9.87	34.36	8.51	34.05	200	332	Average
5458.48	54.15	45.33	74	-19.85	34.36	8.51	34.05	200	332	Peak
*5469.52	54.12	45.29	68.2	-14.08	34.37	8.51	34.05	200	332	Peak
5580	98.77	89.78			34.47	8.6	34.08	200	332	Average
5580	106.95	97.96			34.47	8.6	34.08	200	332	Peak
*5724.12	54.1	44.94	68.2	-14.1	34.62	8.65	34.11	200	332	Peak

Remarks:

- Emission Level = Read Level + Antenna Factor + Cable Loss - Preamp Factor
Margin value = Emission level – Limit value
- 5580 MHz: Fundamental Frequency
- *: Out of Restricted Band

EUT Test Condition		Measurement Detail	
Channel	Channel 140	Frequency Range	1 GHz ~ 40 GHz
Input Power	120 Vac, 60 Hz	Detector Function	Peak (PK) Average (AV)
Environmental Conditions	25 deg. C, 65 % RH	Tested By	Karl Lee

Antenna Polarity & Test Distance: Horizontal at 3 m										
Frequency (MHz)	Emission Level (dBuV/m)	Read Level (dBuV)	Limit (dBuV/m)	Margin (dB)	Antenna Factor (dB/m)	Cable Loss (dB)	Preamp Factor (dB)	Antenna Height (cm)	Table Angle (Degree)	Remark
5700	88.52	79.39			34.59	8.64	34.1	100	300	Average
5700	96.21	87.08			34.59	8.64	34.1	100	300	Peak
*5724.6	54.88	45.72	68.2	-13.32	34.62	8.65	34.11	100	300	Peak
11400	47.25	32.15	54	-6.75	37.84	12.67	35.41	105	24	Average
11400	57.72	42.62	74	-16.28	37.84	12.67	35.41	105	24	Peak

Antenna Polarity & Test Distance: Vertical at 3 m										
Frequency (MHz)	Emission Level (dBuV/m)	Read Level (dBuV)	Limit (dBuV/m)	Margin (dB)	Antenna Factor (dB/m)	Cable Loss (dB)	Preamp Factor (dB)	Antenna Height (cm)	Table Angle (Degree)	Remark
5700	95.46	86.33			34.59	8.64	34.1	195	343	Average
5700	103.35	94.22			34.59	8.64	34.1	195	343	Peak
*5725.72	60.96	51.8	68.2	-7.24	34.62	8.65	34.11	195	343	Peak
11400	47.7	32.6	54	-6.3	37.84	12.67	35.41	132	225	Average
11400	56.72	41.62	74	-17.28	37.84	12.67	35.41	132	225	Peak

Remarks:

- Emission Level = Read Level + Antenna Factor + Cable Loss - Preamp Factor
Margin value = Emission level – Limit value
- 5700 MHz: Fundamental Frequency
- *: Out of Restricted Band

EUT Test Condition		Measurement Detail	
Channel	Channel 149	Frequency Range	1 GHz ~ 40 GHz
Input Power	120 Vac, 60 Hz	Detector Function	Peak (PK) Average (AV)
Environmental Conditions	25 deg. C, 65 % RH	Tested By	Karl Lee

<Spurious Emission>

Antenna Polarity & Test Distance: Horizontal at 3 m										
Frequency (MHz)	Emission Level (dBuV/m)	Read Level (dBuV)	Limit (dBuV/m)	Margin (dB)	Antenna Factor (dB/m)	Cable Loss (dB)	Preamp Factor (dB)	Antenna Height (cm)	Table Angle (Degree)	Remark
5745	95.31	86.12			34.64	8.66	34.11	121	296	Average
5745	103.02	93.83			34.64	8.66	34.11	121	296	Peak
11490	47.39	32.27	54	-6.61	37.89	12.62	35.39	141	352	Average
11490	58.17	43.05	74	-15.83	37.89	12.62	35.39	141	352	Peak
Antenna Polarity & Test Distance: Vertical at 3 m										
Frequency (MHz)	Emission Level (dBuV/m)	Read Level (dBuV)	Limit (dBuV/m)	Margin (dB)	Antenna Factor (dB/m)	Cable Loss (dB)	Preamp Factor (dB)	Antenna Height (cm)	Table Angle (Degree)	Remark
5745	100.42	91.23			34.64	8.66	34.11	255	26	Average
5745	108.35	99.16			34.64	8.66	34.11	255	26	Peak
11490	47.42	32.3	54	-6.58	37.89	12.62	35.39	105	233	Average
11490	58.03	42.91	74	-15.97	37.89	12.62	35.39	105	233	Peak

<Out of Band Emission (OOBE)>

Antenna Polarity & Test Distance: Horizontal at 3 m										
Frequency (MHz)	Emission Level (dBuV/m)	Read Level (dBuV)	Limit (dBuV/m)	Margin (dB)	Antenna Factor (dB/m)	Cable Loss (dB)	Preamp Factor (dB)	Antenna Height (cm)	Table Angle (Degree)	Remark
*5600.275	54.11	45.09	68.2	-14.09	34.5	8.6	34.08	121	296	Peak
5654.875	54.49	45.4	71.81	-17.32	34.56	8.63	34.1	121	296	Peak
5923.675	51.8	42.4	69.18	-17.38	34.83	8.73	34.16	121	296	Peak
*5989.825	53.55	44.07	68.2	-14.65	34.9	8.75	34.17	121	296	Peak
Antenna Polarity & Test Distance: Vertical at 3 m										
Frequency (MHz)	Emission Level (dBuV/m)	Read Level (dBuV)	Limit (dBuV/m)	Margin (dB)	Antenna Factor (dB/m)	Cable Loss (dB)	Preamp Factor (dB)	Antenna Height (cm)	Table Angle (Degree)	Remark
*5504.2	54.6	45.69	68.2	-13.6	34.4	8.57	34.06	255	26	Peak
5652.25	50.89	41.8	69.86	-18.97	34.56	8.62	34.09	255	26	Peak
5923.675	51.68	42.28	69.18	-17.5	34.83	8.73	34.16	255	26	Peak
*5943.1	54.58	45.15	68.2	-13.62	34.85	8.74	34.16	255	26	Peak

Remarks:

- Emission Level = Read Level + Antenna Factor + Cable Loss - Preamp Factor
Margin value = Emission level – Limit value
- 5745 MHz: Fundamental Frequency
- *: Out of Restricted Band

EUT Test Condition		Measurement Detail	
Channel	Channel 157	Frequency Range	1 GHz ~ 40 GHz
Input Power	120 Vac, 60 Hz	Detector Function	Peak (PK) Average (AV)
Environmental Conditions	25 deg. C, 65 % RH	Tested By	Karl Lee

<Spurious Emission>

Antenna Polarity & Test Distance: Horizontal at 3 m										
Frequency (MHz)	Emission Level (dBuV/m)	Read Level (dBuV)	Limit (dBuV/m)	Margin (dB)	Antenna Factor (dB/m)	Cable Loss (dB)	Preamp Factor (dB)	Antenna Height (cm)	Table Angle (Degree)	Remark
5785	95.64	86.41			34.68	8.68	34.13	100	48	Average
5785	103.24	94.01			34.68	8.68	34.13	100	48	Peak
11570	47.18	31.87	54	-6.82	38	12.68	35.37	132	177	Average
11570	56.9	41.59	74	-17.1	38	12.68	35.37	132	177	Peak
Antenna Polarity & Test Distance: Vertical at 3 m										
Frequency (MHz)	Emission Level (dBuV/m)	Read Level (dBuV)	Limit (dBuV/m)	Margin (dB)	Antenna Factor (dB/m)	Cable Loss (dB)	Preamp Factor (dB)	Antenna Height (cm)	Table Angle (Degree)	Remark
5785	101.26	92.03			34.68	8.68	34.13	185	332	Average
5785	108.66	99.43			34.68	8.68	34.13	185	332	Peak
11570	46.35	31.04	54	-7.65	38	12.68	35.37	159	228	Average
11570	56.31	41	74	-17.69	38	12.68	35.37	159	228	Peak

<Out of Band Emission (OOBE)>

Antenna Polarity & Test Distance: Horizontal at 3 m										
Frequency (MHz)	Emission Level (dBuV/m)	Read Level (dBuV)	Limit (dBuV/m)	Margin (dB)	Antenna Factor (dB/m)	Cable Loss (dB)	Preamp Factor (dB)	Antenna Height (cm)	Table Angle (Degree)	Remark
*5597.65	53.13	44.12	68.2	-15.07	34.49	8.6	34.08	100	48	Peak
5651.725	51.06	41.97	69.48	-18.42	34.56	8.62	34.09	100	48	Peak
5922.625	51.28	41.88	69.96	-18.68	34.83	8.73	34.16	100	48	Peak
*5989.3	52.78	43.32	68.2	-15.42	34.88	8.75	34.17	100	48	Peak
Antenna Polarity & Test Distance: Vertical at 3 m										
Frequency (MHz)	Emission Level (dBuV/m)	Read Level (dBuV)	Limit (dBuV/m)	Margin (dB)	Antenna Factor (dB/m)	Cable Loss (dB)	Preamp Factor (dB)	Antenna Height (cm)	Table Angle (Degree)	Remark
*5623.9	53.89	44.84	68.2	-14.31	34.52	8.61	34.08	185	332	Peak
5651.725	50.25	41.16	69.48	-19.23	34.56	8.62	34.09	185	332	Peak
5923.675	50.88	41.48	69.18	-18.3	34.83	8.73	34.16	185	332	Peak
*6009.775	53.36	43.85	68.2	-14.84	34.92	8.76	34.17	185	332	Peak

Remarks:

- Emission Level = Read Level + Antenna Factor + Cable Loss - Preamp Factor
Margin value = Emission level – Limit value
- 5785 MHz: Fundamental Frequency
- *: Out of Restricted Band

EUT Test Condition		Measurement Detail	
Channel	Channel 165	Frequency Range	1 GHz ~ 40 GHz
Input Power	120 Vac, 60 Hz	Detector Function	Peak (PK) Average (AV)
Environmental Conditions	25 deg. C, 65 % RH	Tested By	Karl Lee

<Spurious Emission>

Antenna Polarity & Test Distance: Horizontal at 3 m										
Frequency (MHz)	Emission Level (dBuV/m)	Read Level (dBuV)	Limit (dBuV/m)	Margin (dB)	Antenna Factor (dB/m)	Cable Loss (dB)	Preamp Factor (dB)	Antenna Height (cm)	Table Angle (Degree)	Remark
5825	96.47	87.18			34.73	8.69	34.13	100	48	Average
5825	103.46	94.17			34.73	8.69	34.13	100	48	Peak
11650	47.45	31.92	54	-6.55	38.09	12.8	35.36	187	245	Average
11650	57.62	42.09	74	-16.38	38.09	12.8	35.36	187	245	Peak
Antenna Polarity & Test Distance: Vertical at 3 m										
Frequency (MHz)	Emission Level (dBuV/m)	Read Level (dBuV)	Limit (dBuV/m)	Margin (dB)	Antenna Factor (dB/m)	Cable Loss (dB)	Preamp Factor (dB)	Antenna Height (cm)	Table Angle (Degree)	Remark
5825	101.41	92.12			34.73	8.69	34.13	185	332	Average
5825	108.72	99.43			34.73	8.69	34.13	185	332	Peak
11650	46.23	30.7	54	-7.77	38.09	12.8	35.36	162	68	Average
11650	56.04	40.51	74	-17.96	38.09	12.8	35.36	162	68	Peak

<Out of Band Emission (OOBE)>

Antenna Polarity & Test Distance: Horizontal at 3 m										
Frequency (MHz)	Emission Level (dBuV/m)	Read Level (dBuV)	Limit (dBuV/m)	Margin (dB)	Antenna Factor (dB/m)	Cable Loss (dB)	Preamp Factor (dB)	Antenna Height (cm)	Table Angle (Degree)	Remark
*5588.725	52.7	43.69	68.2	-15.5	34.49	8.6	34.08	100	48	Peak
5652.25	49.93	40.84	69.86	-19.93	34.56	8.62	34.09	100	48	Peak
5922.625	51.29	41.89	69.96	-18.67	34.83	8.73	34.16	100	48	Peak
*5943.1	53.99	44.56	68.2	-14.21	34.85	8.74	34.16	100	48	Peak
Antenna Polarity & Test Distance: Vertical at 3 m										
Frequency (MHz)	Emission Level (dBuV/m)	Read Level (dBuV)	Limit (dBuV/m)	Margin (dB)	Antenna Factor (dB/m)	Cable Loss (dB)	Preamp Factor (dB)	Antenna Height (cm)	Table Angle (Degree)	Remark
*5592.4	53.72	44.71	68.2	-14.48	34.49	8.6	34.08	185	332	Peak
5651.2	49.36	40.27	69.09	-19.73	34.56	8.62	34.09	185	332	Peak
5923.675	49.93	40.53	69.18	-19.25	34.83	8.73	34.16	185	332	Peak
*5945.2	52.9	43.47	68.2	-15.3	34.85	8.74	34.16	185	332	Peak

Remarks:

- Emission Level = Read Level + Antenna Factor + Cable Loss - Preamp Factor
Margin value = Emission level – Limit value
- 5825 MHz: Fundamental Frequency
- *: Out of Restricted Band

802.11n (HT20)

EUT Test Condition		Measurement Detail	
Channel	Channel 36	Frequency Range	1 GHz ~ 40 GHz
Input Power	120 Vac, 60 Hz	Detector Function	Peak (PK) Average (AV)
Environmental Conditions	25 deg. C, 65 % RH	Tested By	Karl Lee

Antenna Polarity & Test Distance: Horizontal at 3 m

Frequency (MHz)	Emission Level (dBuV/m)	Read Level (dBuV)	Limit (dBuV/m)	Margin (dB)	Antenna Factor (dB/m)	Cable Loss (dB)	Preamp Factor (dB)	Antenna Height (cm)	Table Angle (Degree)	Remark
5149.85	46.58	38.33	54	-7.42	34.12	8.13	34	101	28	Average
5149.85	58.09	49.84	74	-15.91	34.12	8.13	34	101	28	Peak
5180	98.57	56.26			34.15	8.16	0	101	35	Average
5180	106.47	64.16			34.15	8.16	0	101	35	Peak
*10360	54.6	40.3	68.2	-13.6	37.12	12.3	35.12	119	148	Peak

Antenna Polarity & Test Distance: Vertical at 3 m

Frequency (MHz)	Emission Level (dBuV/m)	Read Level (dBuV)	Limit (dBuV/m)	Margin (dB)	Antenna Factor (dB/m)	Cable Loss (dB)	Preamp Factor (dB)	Antenna Height (cm)	Table Angle (Degree)	Remark
5148.5	43.04	34.79	54	-10.96	34.12	8.13	34	126	62	Average
5148.5	52.98	44.73	74	-21.02	34.12	8.13	34	126	62	Peak
5180	91.21	82.9			34.15	8.16	34	126	62	Average
5180	99.15	90.84			34.15	8.16	34	126	62	Peak
*10360	54.63	40.33	68.2	-13.57	37.12	12.3	35.12	149	215	Peak

Remarks:

- Emission Level = Read Level + Antenna Factor + Cable Loss - Preamp Factor
Margin value = Emission level – Limit value
- 5180 MHz: Fundamental Frequency
- *: Out of Restricted Band

EUT Test Condition		Measurement Detail	
Channel	Channel 44	Frequency Range	1 GHz ~ 40 GHz
Input Power	120 Vac, 60 Hz	Detector Function	Peak (PK) Average (AV)
Environmental Conditions	25 deg. C, 65 % RH	Tested By	Karl Lee

Antenna Polarity & Test Distance: Horizontal at 3 m										
Frequency (MHz)	Emission Level (dBuV/m)	Read Level (dBuV)	Limit (dBuV/m)	Margin (dB)	Antenna Factor (dB/m)	Cable Loss (dB)	Preamp Factor (dB)	Antenna Height (cm)	Table Angle (Degree)	Remark
5149.4	46.18	37.93	54	-7.82	34.12	8.13	34	123	32	Average
5149.4	56.17	47.92	74	-17.83	34.12	8.13	34	123	32	Peak
5220	101.73	93.34			34.17	8.22	34	123	32	Average
5220	109.6	101.21			34.17	8.22	34	123	32	Peak
5372.66	43.28	34.61	54	-10.72	34.29	8.41	34.03	123	32	Average
5372.66	53.77	45.1	74	-20.23	34.29	8.41	34.03	123	32	Peak

Antenna Polarity & Test Distance: Vertical at 3 m										
Frequency (MHz)	Emission Level (dBuV/m)	Read Level (dBuV)	Limit (dBuV/m)	Margin (dB)	Antenna Factor (dB/m)	Cable Loss (dB)	Preamp Factor (dB)	Antenna Height (cm)	Table Angle (Degree)	Remark
5141.75	43.08	34.82	54	-10.92	34.12	8.13	33.99	126	62	Average
5141.75	53.86	45.6	74	-20.14	34.12	8.13	33.99	126	62	Peak
5220	94.67	86.28			34.17	8.22	34	126	62	Average
5220	102.79	94.4			34.17	8.22	34	126	62	Peak
5376.84	42.65	33.99	54	-11.35	34.29	8.41	34.04	126	62	Average
5376.84	53.1	44.44	74	-20.9	34.29	8.41	34.04	126	62	Peak

Remarks:

- Emission Level = Read Level + Antenna Factor + Cable Loss - Preamp Factor
Margin value = Emission level – Limit value
- 5220 MHz: Fundamental Frequency

EUT Test Condition		Measurement Detail	
Channel	Channel 48	Frequency Range	1 GHz ~ 40 GHz
Input Power	120 Vac, 60 Hz	Detector Function	Peak (PK) Average (AV)
Environmental Conditions	25 deg. C, 65 % RH	Tested By	Karl Lee

Antenna Polarity & Test Distance: Horizontal at 3 m										
Frequency (MHz)	Emission Level (dBuV/m)	Read Level (dBuV)	Limit (dBuV/m)	Margin (dB)	Antenna Factor (dB/m)	Cable Loss (dB)	Preamp Factor (dB)	Antenna Height (cm)	Table Angle (Degree)	Remark
5240	102.09	93.65			34.19	8.26	34.01	123	32	Average
5240	109.59	101.15			34.19	8.26	34.01	123	32	Peak
5353.74	42.97	34.34	54	-11.03	34.28	8.38	34.03	123	32	Average
5353.74	53.55	44.92	74	-20.45	34.28	8.38	34.03	123	32	Peak
*10480	54.44	39.93	68.2	-13.76	37.19	12.53	35.21	165	312	Peak

Antenna Polarity & Test Distance: Vertical at 3 m										
Frequency (MHz)	Emission Level (dBuV/m)	Read Level (dBuV)	Limit (dBuV/m)	Margin (dB)	Antenna Factor (dB/m)	Cable Loss (dB)	Preamp Factor (dB)	Antenna Height (cm)	Table Angle (Degree)	Remark
5240	94.46	86.02			34.19	8.26	34.01	126	62	Average
5240	102.43	93.99			34.19	8.26	34.01	126	62	Peak
5374.31	42.58	33.92	54	-11.42	34.29	8.41	34.04	126	62	Average
5374.31	53.84	45.18	74	-20.16	34.29	8.41	34.04	126	62	Peak
*10480	54.73	40.22	68.2	-13.47	37.19	12.53	35.21	152	76	Peak

Remarks:

- Emission Level = Read Level + Antenna Factor + Cable Loss - Preamp Factor
Margin value = Emission level – Limit value
- 5240 MHz: Fundamental Frequency
- *: Out of Restricted Band

EUT Test Condition		Measurement Detail	
Channel	Channel 52	Frequency Range	1 GHz ~ 40 GHz
Input Power	120 Vac, 60 Hz	Detector Function	Peak (PK) Average (AV)
Environmental Conditions	25 deg. C, 65 % RH	Tested By	Karl Lee

Antenna Polarity & Test Distance: Horizontal at 3 m										
Frequency (MHz)	Emission Level (dBuV/m)	Read Level (dBuV)	Limit (dBuV/m)	Margin (dB)	Antenna Factor (dB/m)	Cable Loss (dB)	Preamp Factor (dB)	Antenna Height (cm)	Table Angle (Degree)	Remark
5023.1	43.96	35.93	54	-10.04	34.03	7.97	33.97	123	57	Average
5023.1	54.69	46.66	74	-19.31	34.03	7.97	33.97	123	57	Peak
5260	101.5	93.04			34.21	8.26	34.01	123	57	Average
5260	109.47	101.01			34.21	8.26	34.01	123	57	Peak
*10520	56.37	41.78	68.2	-11.83	37.21	12.61	35.23	191	325	Peak

Antenna Polarity & Test Distance: Vertical at 3 m										
Frequency (MHz)	Emission Level (dBuV/m)	Read Level (dBuV)	Limit (dBuV/m)	Margin (dB)	Antenna Factor (dB/m)	Cable Loss (dB)	Preamp Factor (dB)	Antenna Height (cm)	Table Angle (Degree)	Remark
5147	42.54	34.29	54	-11.46	34.12	8.13	34	116	59	Average
5147	53.79	45.54	74	-20.21	34.12	8.13	34	116	59	Peak
5260	97.5	89.04			34.21	8.26	34.01	116	59	Average
5260	103.36	94.9			34.21	8.26	34.01	116	59	Peak
*10520	54.71	40.12	68.2	-13.49	37.21	12.61	35.23	182	223	Peak

Remarks:

- Emission Level = Read Level + Antenna Factor + Cable Loss - Preamp Factor
Margin value = Emission level – Limit value
- 5260 MHz: Fundamental Frequency
- *: Out of Restricted Band

EUT Test Condition		Measurement Detail	
Channel	Channel 60	Frequency Range	1 GHz ~ 40 GHz
Input Power	120 Vac, 60 Hz	Detector Function	Peak (PK) Average (AV)
Environmental Conditions	25 deg. C, 65 % RH	Tested By	Karl Lee

Antenna Polarity & Test Distance: Horizontal at 3 m										
Frequency (MHz)	Emission Level (dBuV/m)	Read Level (dBuV)	Limit (dBuV/m)	Margin (dB)	Antenna Factor (dB/m)	Cable Loss (dB)	Preamp Factor (dB)	Antenna Height (cm)	Table Angle (Degree)	Remark
5143.1	44.36	36.1	54	-9.64	34.12	8.13	33.99	123	57	Average
5143.1	54.68	46.42	74	-19.32	34.12	8.13	33.99	123	57	Peak
5300	101.85	93.31			34.24	8.32	34.02	123	57	Average
5300	109.28	100.74			34.24	8.32	34.02	123	57	Peak
5351.32	45.89	37.26	54	-8.11	34.28	8.38	34.03	123	57	Average
5351.32	56.82	48.19	74	-17.18	34.28	8.38	34.03	123	57	Peak

Antenna Polarity & Test Distance: Vertical at 3 m										
Frequency (MHz)	Emission Level (dBuV/m)	Read Level (dBuV)	Limit (dBuV/m)	Margin (dB)	Antenna Factor (dB/m)	Cable Loss (dB)	Preamp Factor (dB)	Antenna Height (cm)	Table Angle (Degree)	Remark
5142.35	42.61	34.35	54	-11.39	34.12	8.13	33.99	116	59	Average
5142.35	52.77	44.51	74	-21.23	34.12	8.13	33.99	116	59	Peak
5300	94.79	86.25			34.24	8.32	34.02	116	59	Average
5300	103.4	94.86			34.24	8.32	34.02	116	59	Peak
5362.87	43.27	34.63	54	-10.73	34.29	8.38	34.03	116	59	Average
5362.87	53.72	45.08	74	-20.28	34.29	8.38	34.03	116	59	Peak

Remarks:

- Emission Level = Read Level + Antenna Factor + Cable Loss - Preamp Factor
Margin value = Emission level – Limit value
- 5300 MHz: Fundamental Frequency

EUT Test Condition		Measurement Detail	
Channel	Channel 64	Frequency Range	1 GHz ~ 40 GHz
Input Power	120 Vac, 60 Hz	Detector Function	Peak (PK) Average (AV)
Environmental Conditions	25 deg. C, 65 % RH	Tested By	Karl Lee

Antenna Polarity & Test Distance: Horizontal at 3 m										
Frequency (MHz)	Emission Level (dBuV/m)	Read Level (dBuV)	Limit (dBuV/m)	Margin (dB)	Antenna Factor (dB/m)	Cable Loss (dB)	Preamp Factor (dB)	Antenna Height (cm)	Table Angle (Degree)	Remark
5320	95.25	86.67			34.25	8.35	34.02	100	352	Average
5320	103.1	94.52			34.25	8.35	34.02	100	352	Peak
5351.32	44	35.37	54	-10	34.28	8.38	34.03	100	352	Average
5351.32	54.02	45.39	74	-19.98	34.28	8.38	34.03	100	352	Peak
10640	45.72	30.99	54	-8.28	37.31	12.71	35.29	124	225	Average
10640	57.11	42.38	74	-16.89	37.31	12.71	35.29	124	225	Peak

Antenna Polarity & Test Distance: Vertical at 3 m										
Frequency (MHz)	Emission Level (dBuV/m)	Read Level (dBuV)	Limit (dBuV/m)	Margin (dB)	Antenna Factor (dB/m)	Cable Loss (dB)	Preamp Factor (dB)	Antenna Height (cm)	Table Angle (Degree)	Remark
5320	89.52	80.94			34.25	8.35	34.02	250	230	Average
5320	97.08	88.5			34.25	8.35	34.02	250	230	Peak
5350.33	42.97	34.34	54	-11.03	34.28	8.38	34.03	250	230	Average
5350.33	53.74	45.11	74	-20.26	34.28	8.38	34.03	250	230	Peak
10640	46.2	31.47	54	-7.8	37.31	12.71	35.29	134	310	Average
10640	58.82	44.09	74	-15.18	37.31	12.71	35.29	134	310	Peak

Remarks:

- Emission Level = Read Level + Antenna Factor + Cable Loss - Preamp Factor
Margin value = Emission level – Limit value
- 5320 MHz: Fundamental Frequency

EUT Test Condition		Measurement Detail	
Channel	Channel 100	Frequency Range	1 GHz ~ 40 GHz
Input Power	120 Vac, 60 Hz	Detector Function	Peak (PK) Average (AV)
Environmental Conditions	25 deg. C, 65 % RH	Tested By	Karl Lee

Antenna Polarity & Test Distance: Horizontal at 3 m										
Frequency (MHz)	Emission Level (dBuV/m)	Read Level (dBuV)	Limit (dBuV/m)	Margin (dB)	Antenna Factor (dB/m)	Cable Loss (dB)	Preamp Factor (dB)	Antenna Height (cm)	Table Angle (Degree)	Remark
5458.96	44.18	35.36	54	-9.82	34.36	8.51	34.05	161	29	Average
5458.96	53.9	45.08	74	-20.1	34.36	8.51	34.05	161	29	Peak
*5469.36	56.34	47.51	68.2	-11.86	34.37	8.51	34.05	161	29	Peak
5500	97.44	88.52			34.4	8.57	34.05	161	26	Average
5500	106.25	97.33			34.4	8.57	34.05	161	26	Peak
11000	47.27	32.19	54	-6.73	37.6	12.96	35.48	148	192	Average
11000	56.46	41.38	74	-17.54	37.6	12.96	35.48	148	192	Peak
Antenna Polarity & Test Distance: Vertical at 3 m										
Frequency (MHz)	Emission Level (dBuV/m)	Read Level (dBuV)	Limit (dBuV/m)	Margin (dB)	Antenna Factor (dB/m)	Cable Loss (dB)	Preamp Factor (dB)	Antenna Height (cm)	Table Angle (Degree)	Remark
5438.48	42.68	33.89	54	-11.32	34.35	8.48	34.04	129	67	Average
5438.48	53.12	44.33	74	-20.88	34.35	8.48	34.04	129	67	Peak
*5469.36	53.35	44.52	68.2	-14.85	34.37	8.51	34.05	129	67	Peak
5500	89.19	80.27			34.4	8.57	34.05	129	67	Average
5500	97.54	88.62			34.4	8.57	34.05	129	67	Peak
11000	47.16	32.08	54	-6.84	37.6	12.96	35.48	167	125	Average
11000	56.25	41.17	74	-17.75	37.6	12.96	35.48	167	125	Peak

Remarks:

- Emission Level = Read Level + Antenna Factor + Cable Loss - Preamp Factor
Margin value = Emission level – Limit value
- 5500 MHz: Fundamental Frequency
- *: Out of Restricted Band

EUT Test Condition		Measurement Detail	
Channel	Channel 116	Frequency Range	1 GHz ~ 40 GHz
Input Power	120 Vac, 60 Hz	Detector Function	Peak (PK) Average (AV)
Environmental Conditions	25 deg. C, 65 % RH	Tested By	Karl Lee

Antenna Polarity & Test Distance: Horizontal at 3 m										
Frequency (MHz)	Emission Level (dBuV/m)	Read Level (dBuV)	Limit (dBuV/m)	Margin (dB)	Antenna Factor (dB/m)	Cable Loss (dB)	Preamp Factor (dB)	Antenna Height (cm)	Table Angle (Degree)	Remark
5448.88	45.46	36.63	54	-8.54	34.36	8.51	34.04	169	28	Average
5448.88	55.71	46.88	74	-18.29	34.36	8.51	34.04	169	28	Peak
*5470.8	55.28	46.42	68.2	-12.92	34.37	8.54	34.05	169	28	Peak
5580	99.91	90.92			34.47	8.6	34.08	169	28	Average
5580	109.23	100.24			34.47	8.6	34.08	169	28	Peak
*5725.24	52.99	43.83	68.2	-15.21	34.62	8.65	34.11	169	28	Peak

Antenna Polarity & Test Distance: Vertical at 3 m										
Frequency (MHz)	Emission Level (dBuV/m)	Read Level (dBuV)	Limit (dBuV/m)	Margin (dB)	Antenna Factor (dB/m)	Cable Loss (dB)	Preamp Factor (dB)	Antenna Height (cm)	Table Angle (Degree)	Remark
5445.68	43.01	34.18	54	-10.99	34.36	8.51	34.04	130	67	Average
5445.68	52.85	44.02	74	-21.15	34.36	8.51	34.04	130	67	Peak
*5469.84	52.19	43.36	68.2	-16.01	34.37	8.51	34.05	130	67	Peak
5580	91.98	82.99			34.47	8.6	34.08	130	67	Average
5580	100.48	91.49			34.47	8.6	34.08	130	67	Peak
*5724.2	52.28	43.12	68.2	-15.92	34.62	8.65	34.11	130	67	Peak

Remarks:

- Emission Level = Read Level + Antenna Factor + Cable Loss - Preamp Factor
Margin value = Emission level – Limit value
- 5580 MHz: Fundamental Frequency
- *: Out of Restricted Band

EUT Test Condition		Measurement Detail	
Channel	Channel 140	Frequency Range	1 GHz ~ 40 GHz
Input Power	120 Vac, 60 Hz	Detector Function	Peak (PK) Average (AV)
Environmental Conditions	25 deg. C, 65 % RH	Tested By	Karl Lee

Antenna Polarity & Test Distance: Horizontal at 3 m										
Frequency (MHz)	Emission Level (dBuV/m)	Read Level (dBuV)	Limit (dBuV/m)	Margin (dB)	Antenna Factor (dB/m)	Cable Loss (dB)	Preamp Factor (dB)	Antenna Height (cm)	Table Angle (Degree)	Remark
5700	88.49	79.36			34.59	8.64	34.1	100	24	Average
5700	96.4	87.27			34.59	8.64	34.1	100	24	Peak
*5724.52	53.18	44.02	68.2	-15.02	34.62	8.65	34.11	100	24	Peak
11400	47.06	31.96	54	-6.94	37.84	12.67	35.41	100	360	Average
11400	57.54	42.44	74	-16.46	37.84	12.67	35.41	100	360	Peak

Antenna Polarity & Test Distance: Vertical at 3 m										
Frequency (MHz)	Emission Level (dBuV/m)	Read Level (dBuV)	Limit (dBuV/m)	Margin (dB)	Antenna Factor (dB/m)	Cable Loss (dB)	Preamp Factor (dB)	Antenna Height (cm)	Table Angle (Degree)	Remark
5700	96.35	87.22			34.59	8.64	34.1	228	218	Average
5700	104.44	95.31			34.59	8.64	34.1	228	218	Peak
*5724.76	54.95	45.79	68.2	-13.25	34.62	8.65	34.11	228	218	Peak
11400	47.16	32.06	54	-6.84	37.84	12.67	35.41	100	0	Average
11400	57.62	42.52	74	-16.38	37.84	12.67	35.41	100	0	Peak

Remarks:

- Emission Level = Read Level + Antenna Factor + Cable Loss - Preamp Factor
Margin value = Emission level – Limit value
- 5700 MHz: Fundamental Frequency
- *: Out of Restricted Band

EUT Test Condition		Measurement Detail	
Channel	Channel 149	Frequency Range	1 GHz ~ 40 GHz
Input Power	120 Vac, 60 Hz	Detector Function	Peak (PK) Average (AV)
Environmental Conditions	25 deg. C, 65 % RH	Tested By	Karl Lee

<Spurious Emission>

Antenna Polarity & Test Distance: Horizontal at 3 m										
Frequency (MHz)	Emission Level (dBuV/m)	Read Level (dBuV)	Limit (dBuV/m)	Margin (dB)	Antenna Factor (dB/m)	Cable Loss (dB)	Preamp Factor (dB)	Antenna Height (cm)	Table Angle (Degree)	Remark
5745	100.11	90.92			34.64	8.66	34.11	149	2	Average
5745	108.6	99.41			34.64	8.66	34.11	149	2	Peak
11490	47.04	31.92	54	-6.96	37.89	12.62	35.39	143	237	Average
11490	56.85	41.73	74	-17.15	37.89	12.62	35.39	143	237	Peak

Antenna Polarity & Test Distance: Vertical at 3 m										
Frequency (MHz)	Emission Level (dBuV/m)	Read Level (dBuV)	Limit (dBuV/m)	Margin (dB)	Antenna Factor (dB/m)	Cable Loss (dB)	Preamp Factor (dB)	Antenna Height (cm)	Table Angle (Degree)	Remark
5745	91.89	82.7			34.64	8.66	34.11	102	58	Average
5745	101.97	92.78			34.64	8.66	34.11	102	58	Peak
11490	46.68	31.56	54	-7.32	37.89	12.62	35.39	135	268	Average
11490	56.41	41.29	74	-17.59	37.89	12.62	35.39	135	268	Peak

<Out of Band Emission (OOBE)>

Antenna Polarity & Test Distance: Horizontal at 3 m										
Frequency (MHz)	Emission Level (dBuV/m)	Read Level (dBuV)	Limit (dBuV/m)	Margin (dB)	Antenna Factor (dB/m)	Cable Loss (dB)	Preamp Factor (dB)	Antenna Height (cm)	Table Angle (Degree)	Remark
*5644.9	55.3	46.23	68.2	-12.9	34.54	8.62	34.09	149	2	Peak
5651.725	54.12	45.03	69.48	-15.36	34.56	8.62	34.09	149	2	Peak
5923.15	49.25	39.85	69.57	-20.32	34.83	8.73	34.16	149	2	Peak
*5966.725	53.88	44.43	68.2	-14.32	34.87	8.75	34.17	149	2	Peak

Antenna Polarity & Test Distance: Vertical at 3 m										
Frequency (MHz)	Emission Level (dBuV/m)	Read Level (dBuV)	Limit (dBuV/m)	Margin (dB)	Antenna Factor (dB/m)	Cable Loss (dB)	Preamp Factor (dB)	Antenna Height (cm)	Table Angle (Degree)	Remark
*5619.7	53.24	44.19	68.2	-14.96	34.52	8.61	34.08	102	58	Peak
5652.25	51.81	42.72	69.86	-18.05	34.56	8.62	34.09	102	58	Peak
5923.675	50.1	40.7	69.18	-19.08	34.83	8.73	34.16	102	58	Peak
*5996.125	53.8	44.31	68.2	-14.4	34.9	8.76	34.17	102	58	Peak

Remarks:

- Emission Level = Read Level + Antenna Factor + Cable Loss - Preamp Factor
Margin value = Emission level – Limit value
- 5745 MHz: Fundamental Frequency
- *: Out of Restricted Band

EUT Test Condition		Measurement Detail	
Channel	Channel 157	Frequency Range	1 GHz ~ 40 GHz
Input Power	120 Vac, 60 Hz	Detector Function	Peak (PK) Average (AV)
Environmental Conditions	25 deg. C, 65 % RH	Tested By	Karl Lee

<Spurious Emission>

Antenna Polarity & Test Distance: Horizontal at 3 m										
Frequency (MHz)	Emission Level (dBuV/m)	Read Level (dBuV)	Limit (dBuV/m)	Margin (dB)	Antenna Factor (dB/m)	Cable Loss (dB)	Preamp Factor (dB)	Antenna Height (cm)	Table Angle (Degree)	Remark
5785	99.63	90.4			34.68	8.68	34.13	100	356	Average
5785	107.07	97.84			34.68	8.68	34.13	100	356	Peak
11570	47.85	32.54	54	-6.15	38	12.68	35.37	134	158	Average
11570	57.85	42.54	74	-16.15	38	12.68	35.37	134	158	Peak
Antenna Polarity & Test Distance: Vertical at 3 m										
Frequency (MHz)	Emission Level (dBuV/m)	Read Level (dBuV)	Limit (dBuV/m)	Margin (dB)	Antenna Factor (dB/m)	Cable Loss (dB)	Preamp Factor (dB)	Antenna Height (cm)	Table Angle (Degree)	Remark
5785	94.41	85.18			34.68	8.68	34.13	100	324	Average
5785	102.74	93.51			34.68	8.68	34.13	100	324	Peak
11570	46.81	31.5	54	-7.19	38	12.68	35.37	174	131	Average
11570	56.69	41.38	74	-17.31	38	12.68	35.37	174	131	Peak

<Out of Band Emission (OOBE)>

Antenna Polarity & Test Distance: Horizontal at 3 m										
Frequency (MHz)	Emission Level (dBuV/m)	Read Level (dBuV)	Limit (dBuV/m)	Margin (dB)	Antenna Factor (dB/m)	Cable Loss (dB)	Preamp Factor (dB)	Antenna Height (cm)	Table Angle (Degree)	Remark
*5624.95	54.63	45.58	68.2	-13.57	34.52	8.61	34.08	100	356	Peak
5651.725	52.98	43.89	69.48	-16.5	34.56	8.62	34.09	100	356	Peak
5919.475	53.44	44.06	72.29	-18.85	34.81	8.73	34.16	100	356	Peak
*5939.95	54.35	44.92	68.2	-13.85	34.85	8.74	34.16	100	356	Peak
Antenna Polarity & Test Distance: Vertical at 3 m										
Frequency (MHz)	Emission Level (dBuV/m)	Read Level (dBuV)	Limit (dBuV/m)	Margin (dB)	Antenna Factor (dB/m)	Cable Loss (dB)	Preamp Factor (dB)	Antenna Height (cm)	Table Angle (Degree)	Remark
*5624.425	54.23	45.18	68.2	-13.97	34.52	8.61	34.08	100	324	Peak
5655.4	51.97	42.88	72.2	-20.23	34.56	8.63	34.1	100	324	Peak
5923.675	53.75	44.35	69.18	-15.43	34.83	8.73	34.16	100	324	Peak
*5940.475	55.06	45.63	68.2	-13.14	34.85	8.74	34.16	100	324	Peak

Remarks:

- Emission Level = Read Level + Antenna Factor + Cable Loss - Preamp Factor
Margin value = Emission level – Limit value
- 5785 MHz: Fundamental Frequency
- *: Out of Restricted Band

EUT Test Condition		Measurement Detail	
Channel	Channel 165	Frequency Range	1 GHz ~ 40 GHz
Input Power	120 Vac, 60 Hz	Detector Function	Peak (PK) Average (AV)
Environmental Conditions	25 deg. C, 65 % RH	Tested By	Karl Lee

<Spurious Emission>

Antenna Polarity & Test Distance: Horizontal at 3 m										
Frequency (MHz)	Emission Level (dBuV/m)	Read Level (dBuV)	Limit (dBuV/m)	Margin (dB)	Antenna Factor (dB/m)	Cable Loss (dB)	Preamp Factor (dB)	Antenna Height (cm)	Table Angle (Degree)	Remark
5825	101.5	92.21			34.73	8.69	34.13	149	4	Average
5825	109.45	100.16			34.73	8.69	34.13	149	4	Peak
11650	47.25	31.72	54	-6.75	38.09	12.8	35.36	136	180	Average
11650	56.76	41.23	74	-17.24	38.09	12.8	35.36	136	180	Peak
Antenna Polarity & Test Distance: Vertical at 3 m										
Frequency (MHz)	Emission Level (dBuV/m)	Read Level (dBuV)	Limit (dBuV/m)	Margin (dB)	Antenna Factor (dB/m)	Cable Loss (dB)	Preamp Factor (dB)	Antenna Height (cm)	Table Angle (Degree)	Remark
5825	93.04	83.75			34.73	8.69	34.13	102	58	Average
5825	101.96	92.67			34.73	8.69	34.13	102	58	Peak
11650	46.44	30.91	54	-7.56	38.09	12.8	35.36	118	164	Average
11650	56.31	40.78	74	-17.69	38.09	12.8	35.36	118	164	Peak

<Out of Band Emission (OOBE)>

Antenna Polarity & Test Distance: Horizontal at 3 m										
Frequency (MHz)	Emission Level (dBuV/m)	Read Level (dBuV)	Limit (dBuV/m)	Margin (dB)	Antenna Factor (dB/m)	Cable Loss (dB)	Preamp Factor (dB)	Antenna Height (cm)	Table Angle (Degree)	Remark
*5580.325	54.47	45.48	68.2	-13.73	34.47	8.6	34.08	149	4	Peak
5651.725	52.29	43.2	69.48	-17.19	34.56	8.62	34.09	149	4	Peak
5922.625	52.05	42.65	69.96	-17.91	34.83	8.73	34.16	149	4	Peak
*5973.55	53.77	44.31	68.2	-14.43	34.88	8.75	34.17	149	4	Peak
Antenna Polarity & Test Distance: Vertical at 3 m										
Frequency (MHz)	Emission Level (dBuV/m)	Read Level (dBuV)	Limit (dBuV/m)	Margin (dB)	Antenna Factor (dB/m)	Cable Loss (dB)	Preamp Factor (dB)	Antenna Height (cm)	Table Angle (Degree)	Remark
*5597.65	53.26	44.25	68.2	-14.94	34.49	8.6	34.08	102	58	Peak
5652.25	51.74	42.65	69.86	-18.12	34.56	8.62	34.09	102	58	Peak
5923.675	49.38	39.98	69.18	-19.8	34.83	8.73	34.16	102	58	Peak
*6020.8	52.32	42.81	68.2	-15.88	34.92	8.77	34.18	102	58	Peak

Remarks:

- Emission Level = Read Level + Antenna Factor + Cable Loss - Preamp Factor
Margin value = Emission level – Limit value
- 5825 MHz: Fundamental Frequency
- *: Out of Restricted Band

802.11n (HT40)

EUT Test Condition		Measurement Detail	
Channel	Channel 38	Frequency Range	1 GHz ~ 40 GHz
Input Power	120 Vac, 60 Hz	Detector Function	Peak (PK) Average (AV)
Environmental Conditions	25 deg. C, 65 % RH	Tested By	Karl Lee

Antenna Polarity & Test Distance: Horizontal at 3 m

Frequency (MHz)	Emission Level (dBuV/m)	Read Level (dBuV)	Limit (dBuV/m)	Margin (dB)	Antenna Factor (dB/m)	Cable Loss (dB)	Preamp Factor (dB)	Antenna Height (cm)	Table Angle (Degree)	Remark
5149.25	43.88	35.63	54	-10.12	34.12	8.13	34	124	32	Average
5149.25	53.61	45.36	74	-20.39	34.12	8.13	34	124	32	Peak
5190	91.36	83.02			34.15	8.19	34	124	32	Average
5190	99.71	91.37			34.15	8.19	34	124	32	Peak
5424.91	42.52	33.75	54	-11.48	34.33	8.48	34.04	124	32	Average
5424.91	53.1	44.33	74	-20.9	34.33	8.48	34.04	124	32	Peak

Antenna Polarity & Test Distance: Vertical at 3 m

Frequency (MHz)	Emission Level (dBuV/m)	Read Level (dBuV)	Limit (dBuV/m)	Margin (dB)	Antenna Factor (dB/m)	Cable Loss (dB)	Preamp Factor (dB)	Antenna Height (cm)	Table Angle (Degree)	Remark
5145.05	42.31	34.06	54	-11.69	34.12	8.13	34	126	62	Average
5145.05	53.45	45.2	74	-20.55	34.12	8.13	34	126	62	Peak
5190	84.16	75.82			34.15	8.19	34	126	62	Average
5190	92.49	84.15			34.15	8.19	34	126	62	Peak
5362.32	42.42	33.78	54	-11.58	34.29	8.38	34.03	126	62	Average
5362.32	53.38	44.74	74	-20.62	34.29	8.38	34.03	126	62	Peak

Remarks:

- Emission Level = Read Level + Antenna Factor + Cable Loss - Preamp Factor
Margin value = Emission level – Limit value
- 5190 MHz: Fundamental Frequency

EUT Test Condition		Measurement Detail	
Channel	Channel 46	Frequency Range	1 GHz ~ 40 GHz
Input Power	120 Vac, 60 Hz	Detector Function	Peak (PK) Average (AV)
Environmental Conditions	25 deg. C, 65 % RH	Tested By	Karl Lee

Antenna Polarity & Test Distance: Horizontal at 3 m										
Frequency (MHz)	Emission Level (dBuV/m)	Read Level (dBuV)	Limit (dBuV/m)	Margin (dB)	Antenna Factor (dB/m)	Cable Loss (dB)	Preamp Factor (dB)	Antenna Height (cm)	Table Angle (Degree)	Remark
5150	45.42	37.17	54	-8.58	34.12	8.13	34	100	8	Average
5150	54.58	46.33	74	-19.42	34.12	8.13	34	100	8	Peak
5230	99.25	90.85			34.19	8.22	34.01	100	8	Average
5230	106.09	97.69			34.19	8.22	34.01	100	8	Peak
5352.86	44.08	35.45	54	-9.92	34.28	8.38	34.03	100	8	Average
5352.86	54.35	45.72	74	-19.65	34.28	8.38	34.03	100	8	Peak

Antenna Polarity & Test Distance: Vertical at 3 m										
Frequency (MHz)	Emission Level (dBuV/m)	Read Level (dBuV)	Limit (dBuV/m)	Margin (dB)	Antenna Factor (dB/m)	Cable Loss (dB)	Preamp Factor (dB)	Antenna Height (cm)	Table Angle (Degree)	Remark
5130.8	43.69	35.47	54	-10.31	34.11	8.1	33.99	250	231	Average
5130.8	53.8	45.58	74	-20.2	34.11	8.1	33.99	250	231	Peak
5230	93.5	85.1			34.19	8.22	34.01	250	231	Average
5230	100.47	92.07			34.19	8.22	34.01	250	231	Peak
5451.75	43.48	34.66	54	-10.52	34.36	8.51	34.05	250	231	Average
5451.75	53.66	44.84	74	-20.34	34.36	8.51	34.05	250	231	Peak

Remarks:

- Emission Level = Read Level + Antenna Factor + Cable Loss - Preamp Factor
Margin value = Emission level – Limit value
- 5230 MHz: Fundamental Frequency

EUT Test Condition		Measurement Detail	
Channel	Channel 54	Frequency Range	1 GHz ~ 40 GHz
Input Power	120 Vac, 60 Hz	Detector Function	Peak (PK) Average (AV)
Environmental Conditions	25 deg. C, 65 % RH	Tested By	Karl Lee

Antenna Polarity & Test Distance: Horizontal at 3 m										
Frequency (MHz)	Emission Level (dBuV/m)	Read Level (dBuV)	Limit (dBuV/m)	Margin (dB)	Antenna Factor (dB/m)	Cable Loss (dB)	Preamp Factor (dB)	Antenna Height (cm)	Table Angle (Degree)	Remark
5121.2	44.25	36.05	54	-9.75	34.09	8.1	33.99	123	57	Average
5121.2	54.55	46.35	74	-19.45	34.09	8.1	33.99	123	57	Peak
5270	98.41	89.92			34.21	8.29	34.01	123	57	Average
5270	106.22	97.73			34.21	8.29	34.01	123	57	Peak
5350	45.25	36.62	54	-8.75	34.28	8.38	34.03	123	57	Average
5350	55.07	46.44	74	-18.93	34.28	8.38	34.03	123	57	Peak

Antenna Polarity & Test Distance: Vertical at 3 m										
Frequency (MHz)	Emission Level (dBuV/m)	Read Level (dBuV)	Limit (dBuV/m)	Margin (dB)	Antenna Factor (dB/m)	Cable Loss (dB)	Preamp Factor (dB)	Antenna Height (cm)	Table Angle (Degree)	Remark
5143.7	42.84	34.58	54	-11.16	34.12	8.13	33.99	116	59	Average
5143.7	52.98	44.72	74	-21.02	34.12	8.13	33.99	116	59	Peak
5270	90.78	82.29			34.21	8.29	34.01	116	59	Average
5270	99.24	90.75			34.21	8.29	34.01	116	59	Peak
5350.33	43.46	34.83	54	-10.54	34.28	8.38	34.03	116	59	Average
5350.33	53.13	44.5	74	-20.87	34.28	8.38	34.03	116	59	Peak

Remarks:

- Emission Level = Read Level + Antenna Factor + Cable Loss - Preamp Factor
Margin value = Emission level – Limit value
- 5270 MHz: Fundamental Frequency

EUT Test Condition		Measurement Detail	
Channel	Channel 62	Frequency Range	1 GHz ~ 40 GHz
Input Power	120 Vac, 60 Hz	Detector Function	Peak (PK) Average (AV)
Environmental Conditions	25 deg. C, 65 % RH	Tested By	Karl Lee

Antenna Polarity & Test Distance: Horizontal at 3 m										
Frequency (MHz)	Emission Level (dBuV/m)	Read Level (dBuV)	Limit (dBuV/m)	Margin (dB)	Antenna Factor (dB/m)	Cable Loss (dB)	Preamp Factor (dB)	Antenna Height (cm)	Table Angle (Degree)	Remark
5147.15	42.7	34.45	54	-11.3	34.12	8.13	34	123	57	Average
5147.15	53.02	44.77	74	-20.98	34.12	8.13	34	123	57	Peak
5310	89.59	81.04			34.25	8.32	34.02	123	57	Average
5310	98.13	89.58			34.25	8.32	34.02	123	57	Peak
5351.32	44.16	35.53	54	-9.84	34.28	8.38	34.03	123	57	Average
5351.32	54.14	45.51	74	-19.86	34.28	8.38	34.03	123	57	Peak

Antenna Polarity & Test Distance: Vertical at 3 m										
Frequency (MHz)	Emission Level (dBuV/m)	Read Level (dBuV)	Limit (dBuV/m)	Margin (dB)	Antenna Factor (dB/m)	Cable Loss (dB)	Preamp Factor (dB)	Antenna Height (cm)	Table Angle (Degree)	Remark
5115.05	42.49	34.29	54	-11.51	34.09	8.1	33.99	116	59	Average
5115.05	52.78	44.58	74	-21.22	34.09	8.1	33.99	116	59	Peak
5310	84.39	75.84			34.25	8.32	34.02	116	59	Average
5310	92.41	83.86			34.25	8.32	34.02	116	59	Peak
5450.87	42.72	33.9	54	-11.28	34.36	8.51	34.05	116	59	Average
5450.87	53.56	44.74	74	-20.44	34.36	8.51	34.05	116	59	Peak

Remarks:

- Emission Level = Read Level + Antenna Factor + Cable Loss - Preamp Factor
Margin value = Emission level – Limit value
- 5310 MHz: Fundamental Frequency

EUT Test Condition		Measurement Detail	
Channel	Channel 102	Frequency Range	1 GHz ~ 40 GHz
Input Power	120 Vac, 60 Hz	Detector Function	Peak (PK) Average (AV)
Environmental Conditions	25 deg. C, 65 % RH	Tested By	Karl Lee

Antenna Polarity & Test Distance: Horizontal at 3 m										
Frequency (MHz)	Emission Level (dBuV/m)	Read Level (dBuV)	Limit (dBuV/m)	Margin (dB)	Antenna Factor (dB/m)	Cable Loss (dB)	Preamp Factor (dB)	Antenna Height (cm)	Table Angle (Degree)	Remark
5459.44	44.03	35.21	54	-9.97	34.36	8.51	34.05	149	25	Average
5459.44	54.1	45.28	74	-19.9	34.36	8.51	34.05	149	25	Peak
*5468.24	55.96	47.13	68.2	-12.24	34.37	8.51	34.05	149	25	Peak
5510	91.19	82.28			34.4	8.57	34.06	161	26	Average
5510	99	90.09			34.4	8.57	34.06	161	26	Peak
*5724.28	52.25	43.09	68.2	-15.95	34.62	8.65	34.11	161	26	Peak

Antenna Polarity & Test Distance: Vertical at 3 m										
Frequency (MHz)	Emission Level (dBuV/m)	Read Level (dBuV)	Limit (dBuV/m)	Margin (dB)	Antenna Factor (dB/m)	Cable Loss (dB)	Preamp Factor (dB)	Antenna Height (cm)	Table Angle (Degree)	Remark
5453.52	43.37	34.55	54	-10.63	34.36	8.51	34.05	129	67	Average
5453.52	53.34	44.52	74	-20.66	34.36	8.51	34.05	129	67	Peak
*5470.64	53.61	44.78	68.2	-14.59	34.37	8.51	34.05	129	67	Peak
5510	83.05	74.14			34.4	8.57	34.06	129	67	Average
5510	91.38	82.47			34.4	8.57	34.06	129	67	Peak
*5725.56	52.64	43.48	68.2	-15.56	34.62	8.65	34.11	129	67	Peak

Remarks:

- Emission Level = Read Level + Antenna Factor + Cable Loss - Preamp Factor
Margin value = Emission level – Limit value
- 5510 MHz: Fundamental Frequency
- *: Out of Restricted Band

EUT Test Condition		Measurement Detail	
Channel	Channel 110	Frequency Range	1 GHz ~ 40 GHz
Input Power	120 Vac, 60 Hz	Detector Function	Peak (PK) Average (AV)
Environmental Conditions	25 deg. C, 65 % RH	Tested By	Karl Lee

Antenna Polarity & Test Distance: Horizontal at 3 m										
Frequency (MHz)	Emission Level (dBuV/m)	Read Level (dBuV)	Limit (dBuV/m)	Margin (dB)	Antenna Factor (dB/m)	Cable Loss (dB)	Preamp Factor (dB)	Antenna Height (cm)	Table Angle (Degree)	Remark
5455.76	45.44	36.62	54	-8.56	34.36	8.51	34.05	169	28	Average
5455.76	55.34	46.52	74	-18.66	34.36	8.51	34.05	169	28	Peak
*5468.72	54.86	46.03	68.2	-13.34	34.37	8.51	34.05	169	28	Peak
5550	96.03	87.06			34.45	8.59	34.07	169	28	Average
5550	104.38	95.41			34.45	8.59	34.07	169	28	Peak
*5724.68	53.65	44.49	68.2	-14.55	34.62	8.65	34.11	169	28	Peak

Antenna Polarity & Test Distance: Vertical at 3 m										
Frequency (MHz)	Emission Level (dBuV/m)	Read Level (dBuV)	Limit (dBuV/m)	Margin (dB)	Antenna Factor (dB/m)	Cable Loss (dB)	Preamp Factor (dB)	Antenna Height (cm)	Table Angle (Degree)	Remark
5456.88	43.41	34.59	54	-10.59	34.36	8.51	34.05	130	67	Average
5456.88	53.23	44.41	74	-20.77	34.36	8.51	34.05	130	67	Peak
*5470.8	52.74	43.88	68.2	-15.46	34.37	8.54	34.05	130	67	Peak
5550	88.29	79.32			34.45	8.59	34.07	130	67	Average
5550	95.88	86.91			34.45	8.59	34.07	130	67	Peak
*5725.72	52.09	42.93	68.2	-16.11	34.62	8.65	34.11	130	67	Peak

Remarks:

- Emission Level = Read Level + Antenna Factor + Cable Loss - Preamp Factor
Margin value = Emission level – Limit value
- 5550 MHz: Fundamental Frequency
- *: Out of Restricted Band

EUT Test Condition		Measurement Detail	
Channel	Channel 134	Frequency Range	1 GHz ~ 40 GHz
Input Power	120 Vac, 60 Hz	Detector Function	Peak (PK) Average (AV)
Environmental Conditions	25 deg. C, 65 % RH	Tested By	Karl Lee

Antenna Polarity & Test Distance: Horizontal at 3 m										
Frequency (MHz)	Emission Level (dBuV/m)	Read Level (dBuV)	Limit (dBuV/m)	Margin (dB)	Antenna Factor (dB/m)	Cable Loss (dB)	Preamp Factor (dB)	Antenna Height (cm)	Table Angle (Degree)	Remark
5436.72	43.4	34.61	54	-10.6	34.35	8.48	34.04	146	13	Average
5436.72	54.66	45.87	74	-19.34	34.35	8.48	34.04	146	13	Peak
*5468.56	52.88	44.05	68.2	-15.32	34.37	8.51	34.05	146	13	Peak
5670	94.3	85.2			34.57	8.63	34.1	146	13	Average
5670	103.18	94.08			34.57	8.63	34.1	146	13	Peak
*5724.36	54.75	45.59	68.2	-13.45	34.62	8.65	34.11	146	13	Peak

Antenna Polarity & Test Distance: Vertical at 3 m										
Frequency (MHz)	Emission Level (dBuV/m)	Read Level (dBuV)	Limit (dBuV/m)	Margin (dB)	Antenna Factor (dB/m)	Cable Loss (dB)	Preamp Factor (dB)	Antenna Height (cm)	Table Angle (Degree)	Remark
5436.24	42.87	34.08	54	-11.13	34.35	8.48	34.04	101	57	Average
5436.24	53.49	44.7	74	-20.51	34.35	8.48	34.04	101	57	Peak
*5469.04	51.93	43.1	68.2	-16.27	34.37	8.51	34.05	101	57	Peak
5670	86.41	77.31			34.57	8.63	34.1	101	57	Average
5670	95.1	86			34.57	8.63	34.1	101	57	Peak
*5724.2	52.87	43.71	68.2	-15.33	34.62	8.65	34.11	101	57	Peak

Remarks:

- Emission Level = Read Level + Antenna Factor + Cable Loss - Preamp Factor
Margin value = Emission level – Limit value
- 5670 MHz: Fundamental Frequency
- *: Out of Restricted Band

EUT Test Condition		Measurement Detail	
Channel	Channel 151	Frequency Range	1 GHz ~ 40 GHz
Input Power	120 Vac, 60 Hz	Detector Function	Peak (PK) Average (AV)
Environmental Conditions	25 deg. C, 65 % RH	Tested By	Karl Lee

<Spurious Emission>

Antenna Polarity & Test Distance: Horizontal at 3 m										
Frequency (MHz)	Emission Level (dBuV/m)	Read Level (dBuV)	Limit (dBuV/m)	Margin (dB)	Antenna Factor (dB/m)	Cable Loss (dB)	Preamp Factor (dB)	Antenna Height (cm)	Table Angle (Degree)	Remark
5755	96.3	87.09			34.66	8.66	34.11	149	4	Average
5755	104.88	95.67			34.66	8.66	34.11	149	4	Peak
11510	46.67	31.56	54	-7.33	37.9	12.6	35.39	151	326	Average
11510	56.48	41.37	74	-17.52	37.9	12.6	35.39	151	326	Peak
Antenna Polarity & Test Distance: Vertical at 3 m										
Frequency (MHz)	Emission Level (dBuV/m)	Read Level (dBuV)	Limit (dBuV/m)	Margin (dB)	Antenna Factor (dB/m)	Cable Loss (dB)	Preamp Factor (dB)	Antenna Height (cm)	Table Angle (Degree)	Remark
5755	88.34	79.13			34.66	8.66	34.11	102	58	Average
5755	97.09	87.88			34.66	8.66	34.11	102	58	Peak
11510	46.99	31.88	54	-7.01	37.9	12.6	35.39	145	266	Average
11510	56.84	41.73	74	-17.16	37.9	12.6	35.39	145	266	Peak

<Out of Band Emission (OOBE)>

Antenna Polarity & Test Distance: Horizontal at 3 m										
Frequency (MHz)	Emission Level (dBuV/m)	Read Level (dBuV)	Limit (dBuV/m)	Margin (dB)	Antenna Factor (dB/m)	Cable Loss (dB)	Preamp Factor (dB)	Antenna Height (cm)	Table Angle (Degree)	Remark
*5552.5	53.85	44.88	68.2	-14.35	34.45	8.59	34.07	149	4	Peak
5652.25	52.59	43.5	69.86	-17.27	34.56	8.62	34.09	149	4	Peak
5922.625	49.73	40.33	69.96	-20.23	34.83	8.73	34.16	149	4	Peak
*5981.425	53.55	44.09	68.2	-14.65	34.88	8.75	34.17	149	4	Peak
Antenna Polarity & Test Distance: Vertical at 3 m										
Frequency (MHz)	Emission Level (dBuV/m)	Read Level (dBuV)	Limit (dBuV/m)	Margin (dB)	Antenna Factor (dB/m)	Cable Loss (dB)	Preamp Factor (dB)	Antenna Height (cm)	Table Angle (Degree)	Remark
*5557.225	53.24	44.27	68.2	-14.96	34.45	8.59	34.07	102	58	Peak
5651.725	49.61	40.52	69.48	-19.87	34.56	8.62	34.09	102	58	Peak
5923.675	50.47	41.07	69.18	-18.71	34.83	8.73	34.16	102	58	Peak
*6000.85	53.43	43.94	68.2	-14.77	34.9	8.76	34.17	102	58	Peak

Remarks:

- Emission Level = Read Level + Antenna Factor + Cable Loss - Preamp Factor
Margin value = Emission level – Limit value
- 5755 MHz: Fundamental Frequency
- *: Out of Restricted Band

EUT Test Condition		Measurement Detail	
Channel	Channel 159	Frequency Range	1 GHz ~ 40 GHz
Input Power	120 Vac, 60 Hz	Detector Function	Peak (PK) Average (AV)
Environmental Conditions	25 deg. C, 65 % RH	Tested By	Karl Lee

<Spurious Emission>

Antenna Polarity & Test Distance: Horizontal at 3 m										
Frequency (MHz)	Emission Level (dBuV/m)	Read Level (dBuV)	Limit (dBuV/m)	Margin (dB)	Antenna Factor (dB/m)	Cable Loss (dB)	Preamp Factor (dB)	Antenna Height (cm)	Table Angle (Degree)	Remark
5795	96.35	87.11			34.69	8.68	34.13	149	4	Average
5795	104.92	95.68			34.69	8.68	34.13	149	4	Peak
11590	46.34	30.97	54	-7.66	38.02	12.72	35.37	159	287	Average
11590	56.82	41.45	74	-17.18	38.02	12.72	35.37	159	287	Peak

Antenna Polarity & Test Distance: Vertical at 3 m										
Frequency (MHz)	Emission Level (dBuV/m)	Read Level (dBuV)	Limit (dBuV/m)	Margin (dB)	Antenna Factor (dB/m)	Cable Loss (dB)	Preamp Factor (dB)	Antenna Height (cm)	Table Angle (Degree)	Remark
5795	88.38	79.14			34.69	8.68	34.13	102	58	Average
5795	97.11	87.87			34.69	8.68	34.13	102	58	Peak
11590	47.24	31.87	54	-6.76	38.02	12.72	35.37	170	133	Average
11590	56.52	41.15	74	-17.48	38.02	12.72	35.37	170	133	Peak

<Out of Band Emission (OOBE)>

Antenna Polarity & Test Distance: Horizontal at 3 m										
Frequency (MHz)	Emission Level (dBuV/m)	Read Level (dBuV)	Limit (dBuV/m)	Margin (dB)	Antenna Factor (dB/m)	Cable Loss (dB)	Preamp Factor (dB)	Antenna Height (cm)	Table Angle (Degree)	Remark
*5630.725	53.52	44.47	68.2	-14.68	34.52	8.62	34.09	149	4	Peak
5651.725	51.01	41.92	69.48	-18.47	34.56	8.62	34.09	149	4	Peak
5922.625	51.81	42.41	69.96	-18.15	34.83	8.73	34.16	149	4	Peak
*6006.1	52.8	43.31	68.2	-15.4	34.9	8.76	34.17	149	4	Peak

Antenna Polarity & Test Distance: Vertical at 3 m										
Frequency (MHz)	Emission Level (dBuV/m)	Read Level (dBuV)	Limit (dBuV/m)	Margin (dB)	Antenna Factor (dB/m)	Cable Loss (dB)	Preamp Factor (dB)	Antenna Height (cm)	Table Angle (Degree)	Remark
*5567.2	53.03	44.04	68.2	-15.17	34.47	8.59	34.07	102	58	Peak
5651.725	50.3	41.21	69.48	-19.18	34.56	8.62	34.09	102	58	Peak
5923.15	51.06	41.66	69.57	-18.51	34.83	8.73	34.16	102	58	Peak
*6023.425	53.14	43.63	68.2	-15.06	34.92	8.77	34.18	102	58	Peak

Remarks:

- Emission Level = Read Level + Antenna Factor + Cable Loss - Preamp Factor
Margin value = Emission level – Limit value
- 5795 MHz: Fundamental Frequency
- *: Out of Restricted Band

802.11ac (VHT80)

EUT Test Condition		Measurement Detail	
Channel	Channel 42	Frequency Range	1 GHz ~ 40 GHz
Input Power	120 Vac, 60 Hz	Detector Function	Peak (PK) Average (AV)
Environmental Conditions	25 deg. C, 65 % RH	Tested By	Karl Lee

Antenna Polarity & Test Distance: Horizontal at 3 m

Frequency (MHz)	Emission Level (dBuV/m)	Read Level (dBuV)	Limit (dBuV/m)	Margin (dB)	Antenna Factor (dB/m)	Cable Loss (dB)	Preamp Factor (dB)	Antenna Height (cm)	Table Angle (Degree)	Remark
5149.4	44.7	36.45	54	-9.3	34.12	8.13	34	123	32	Average
5149.4	55.1	46.85	74	-18.9	34.12	8.13	34	123	32	Peak
5210	87.27	78.91			34.17	8.19	34	123	32	Average
5210	95.11	86.75			34.17	8.19	34	123	32	Peak
5374.53	42.83	34.17	54	-11.17	34.29	8.41	34.04	123	32	Average
5374.53	52.99	44.33	74	-21.01	34.29	8.41	34.04	123	32	Peak

Antenna Polarity & Test Distance: Vertical at 3 m

Frequency (MHz)	Emission Level (dBuV/m)	Read Level (dBuV)	Limit (dBuV/m)	Margin (dB)	Antenna Factor (dB/m)	Cable Loss (dB)	Preamp Factor (dB)	Antenna Height (cm)	Table Angle (Degree)	Remark
5144	42.78	34.53	54	-11.22	34.12	8.13	34	126	62	Average
5144	53.03	44.78	74	-20.97	34.12	8.13	34	126	62	Peak
5210	79.95	71.59			34.17	8.19	34	126	62	Average
5210	88.56	80.2			34.17	8.19	34	126	62	Peak
5370.57	42.88	34.21	54	-11.12	34.29	8.41	34.03	126	62	Average
5370.57	53.01	44.34	74	-20.99	34.29	8.41	34.03	126	62	Peak

Remarks:

- Emission Level = Read Level + Antenna Factor + Cable Loss - Preamp Factor
Margin value = Emission level – Limit value
- 5210 MHz: Fundamental Frequency

EUT Test Condition		Measurement Detail	
Channel	Channel 58	Frequency Range	1 GHz ~ 40 GHz
Input Power	120 Vac, 60 Hz	Detector Function	Peak (PK) Average (AV)
Environmental Conditions	25 deg. C, 65 % RH	Tested By	Karl Lee

Antenna Polarity & Test Distance: Horizontal at 3 m										
Frequency (MHz)	Emission Level (dBuV/m)	Read Level (dBuV)	Limit (dBuV/m)	Margin (dB)	Antenna Factor (dB/m)	Cable Loss (dB)	Preamp Factor (dB)	Antenna Height (cm)	Table Angle (Degree)	Remark
5125.85	43.03	34.81	54	-10.97	34.11	8.1	33.99	123	57	Average
5125.85	52.89	44.67	74	-21.11	34.11	8.1	33.99	123	57	Peak
5290	85.43	76.9			34.23	8.32	34.02	123	57	Average
5290	93.87	85.34			34.23	8.32	34.02	123	57	Peak
5350.55	43.74	35.11	54	-10.26	34.28	8.38	34.03	123	57	Average
5350.55	53.89	45.26	74	-20.11	34.28	8.38	34.03	123	57	Peak

Antenna Polarity & Test Distance: Vertical at 3 m										
Frequency (MHz)	Emission Level (dBuV/m)	Read Level (dBuV)	Limit (dBuV/m)	Margin (dB)	Antenna Factor (dB/m)	Cable Loss (dB)	Preamp Factor (dB)	Antenna Height (cm)	Table Angle (Degree)	Remark
5082.65	42.71	34.55	54	-11.29	34.07	8.07	33.98	116	59	Average
5082.65	53.06	44.9	74	-20.94	34.07	8.07	33.98	116	59	Peak
5290	79.59	71.06			34.23	8.32	34.02	116	59	Average
5290	87.6	79.07			34.23	8.32	34.02	116	59	Peak
5442.73	43.18	34.39	54	-10.82	34.35	8.48	34.04	116	59	Average
5442.73	52.83	44.04	74	-21.17	34.35	8.48	34.04	116	59	Peak

Remarks:

- Emission Level = Read Level + Antenna Factor + Cable Loss - Preamp Factor
Margin value = Emission level – Limit value
- 5290 MHz: Fundamental Frequency

EUT Test Condition		Measurement Detail	
Channel	Channel 106	Frequency Range	1 GHz ~ 40 GHz
Input Power	120 Vac, 60 Hz	Detector Function	Peak (PK) Average (AV)
Environmental Conditions	25 deg. C, 65 % RH	Tested By	Karl Lee

Antenna Polarity & Test Distance: Horizontal at 3 m										
Frequency (MHz)	Emission Level (dBuV/m)	Read Level (dBuV)	Limit (dBuV/m)	Margin (dB)	Antenna Factor (dB/m)	Cable Loss (dB)	Preamp Factor (dB)	Antenna Height (cm)	Table Angle (Degree)	Remark
5459.12	45.19	36.37	54	-8.81	34.36	8.51	34.05	157	26	Average
5459.12	54.19	45.37	74	-19.81	34.36	8.51	34.05	157	26	Peak
*5470.64	53.91	45.08	68.2	-14.29	34.37	8.51	34.05	157	26	Peak
5530	86.87	77.94			34.42	8.58	34.07	161	26	Average
5530	95.46	86.53			34.42	8.58	34.07	161	26	Peak
*5724.68	52.35	43.19	68.2	-15.85	34.62	8.65	34.11	161	26	Peak

Antenna Polarity & Test Distance: Vertical at 3 m										
Frequency (MHz)	Emission Level (dBuV/m)	Read Level (dBuV)	Limit (dBuV/m)	Margin (dB)	Antenna Factor (dB/m)	Cable Loss (dB)	Preamp Factor (dB)	Antenna Height (cm)	Table Angle (Degree)	Remark
5444.24	43.4	34.61	54	-10.6	34.35	8.48	34.04	129	67	Average
5444.24	53.35	44.56	74	-20.65	34.35	8.48	34.04	129	67	Peak
*5470.32	51.04	42.21	68.2	-17.16	34.37	8.51	34.05	129	67	Peak
5530	79.24	70.31			34.42	8.58	34.07	129	67	Average
5530	87.23	78.3			34.42	8.58	34.07	129	67	Peak
*5725.32	52.24	43.08	68.2	-15.96	34.62	8.65	34.11	129	67	Peak

Remarks:

- Emission Level = Read Level + Antenna Factor + Cable Loss - Preamp Factor
Margin value = Emission level – Limit value
- 5530 MHz: Fundamental Frequency
- *: Out of Restricted Band

EUT Test Condition		Measurement Detail	
Channel	Channel 122	Frequency Range	1 GHz ~ 40 GHz
Input Power	120 Vac, 60 Hz	Detector Function	Peak (PK) Average (AV)
Environmental Conditions	25 deg. C, 65 % RH	Tested By	Karl Lee

Antenna Polarity & Test Distance: Horizontal at 3 m										
Frequency (MHz)	Emission Level (dBuV/m)	Read Level (dBuV)	Limit (dBuV/m)	Margin (dB)	Antenna Factor (dB/m)	Cable Loss (dB)	Preamp Factor (dB)	Antenna Height (cm)	Table Angle (Degree)	Remark
5451.6	44.73	35.91	54	-9.27	34.36	8.51	34.05	169	28	Average
5451.6	54.36	45.54	74	-19.64	34.36	8.51	34.05	169	28	Peak
*5468.4	53.53	44.7	68.2	-14.67	34.37	8.51	34.05	169	28	Peak
5610	92.32	83.29			34.5	8.61	34.08	169	28	Average
5610	101.08	92.05			34.5	8.61	34.08	169	28	Peak
*5725.16	51.87	42.71	68.32	-16.45	34.62	8.65	34.11	169	28	Peak

Antenna Polarity & Test Distance: Vertical at 3 m										
Frequency (MHz)	Emission Level (dBuV/m)	Read Level (dBuV)	Limit (dBuV/m)	Margin (dB)	Antenna Factor (dB/m)	Cable Loss (dB)	Preamp Factor (dB)	Antenna Height (cm)	Table Angle (Degree)	Remark
5454.16	43.36	34.54	54	-10.64	34.36	8.51	34.05	130	67	Average
5454.16	53.26	44.44	74	-20.74	34.36	8.51	34.05	130	67	Peak
*5470.64	51.81	42.98	68.2	-16.39	34.37	8.51	34.05	130	67	Peak
5610	84.97	75.94			34.5	8.61	34.08	130	67	Average
5610	93.43	84.4			34.5	8.61	34.08	130	67	Peak
*5725.48	51.86	42.7	68.2	-16.34	34.62	8.65	34.11	130	67	Peak

Remarks:

- Emission Level = Read Level + Antenna Factor + Cable Loss - Preamp Factor
Margin value = Emission level – Limit value
- 5610 MHz: Fundamental Frequency
- *: Out of Restricted Band

EUT Test Condition		Measurement Detail	
Channel	Channel 155	Frequency Range	1 GHz ~ 40 GHz
Input Power	120 Vac, 60 Hz	Detector Function	Peak (PK) Average (AV)
Environmental Conditions	25 deg. C, 65 % RH	Tested By	Karl Lee

<Spurious Emission>

Antenna Polarity & Test Distance: Horizontal at 3 m										
Frequency (MHz)	Emission Level (dBuV/m)	Read Level (dBuV)	Limit (dBuV/m)	Margin (dB)	Antenna Factor (dB/m)	Cable Loss (dB)	Preamp Factor (dB)	Antenna Height (cm)	Table Angle (Degree)	Remark
5775	92.99	83.76			34.68	8.67	34.12	149	4	Average
5775	101.28	92.05			34.68	8.67	34.12	149	4	Peak
11550	46.35	31.08	54	-7.65	37.97	12.68	35.38	144	213	Average
11550	56.55	41.28	74	-17.45	37.97	12.68	35.38	144	213	Peak

Antenna Polarity & Test Distance: Vertical at 3 m										
Frequency (MHz)	Emission Level (dBuV/m)	Read Level (dBuV)	Limit (dBuV/m)	Margin (dB)	Antenna Factor (dB/m)	Cable Loss (dB)	Preamp Factor (dB)	Antenna Height (cm)	Table Angle (Degree)	Remark
5775	85.7	76.47			34.68	8.67	34.12	102	58	Average
5775	93.78	84.55			34.68	8.67	34.12	102	58	Peak
11550	46.72	31.45	54	-7.28	37.97	12.68	35.38	136	159	Average
11550	56.63	41.36	74	-17.37	37.97	12.68	35.38	136	159	Peak

<Out of Band Emission (OOBE)>

Antenna Polarity & Test Distance: Horizontal at 3 m										
Frequency (MHz)	Emission Level (dBuV/m)	Read Level (dBuV)	Limit (dBuV/m)	Margin (dB)	Antenna Factor (dB/m)	Cable Loss (dB)	Preamp Factor (dB)	Antenna Height (cm)	Table Angle (Degree)	Remark
*5550.925	52.98	44.01	68.2	-15.22	34.45	8.59	34.07	149	4	Peak
5652.25	51.06	41.97	69.86	-18.8	34.56	8.62	34.09	149	4	Peak
5923.675	51.27	41.87	69.18	-17.91	34.83	8.73	34.16	149	4	Peak
*5953.6	53.12	43.69	68.2	-15.08	34.85	8.74	34.16	149	4	Peak

Antenna Polarity & Test Distance: Vertical at 3 m										
Frequency (MHz)	Emission Level (dBuV/m)	Read Level (dBuV)	Limit (dBuV/m)	Margin (dB)	Antenna Factor (dB/m)	Cable Loss (dB)	Preamp Factor (dB)	Antenna Height (cm)	Table Angle (Degree)	Remark
*5569.825	53.15	44.16	68.2	-15.05	34.47	8.59	34.07	102	58	Peak
5652.25	51.37	42.28	69.86	-18.49	34.56	8.62	34.09	102	58	Peak
5923.15	50.14	40.74	69.57	-19.43	34.83	8.73	34.16	102	58	Peak
*6002.425	53.52	44.03	68.2	-14.68	34.9	8.76	34.17	102	58	Peak

Remarks:

- Emission Level = Read Level + Antenna Factor + Cable Loss - Preamp Factor
Margin value = Emission level – Limit value
- 5775 MHz: Fundamental Frequency
- *: Out of Restricted Band

9 kHz ~ 30 MHz Data:

The amplitude of spurious emissions attenuated more than 20 dB below the permissible value is not required to be report.

30 MHz ~ 1 GHz Worst-Case Data:

802.11a

EUT Test Condition		Measurement Detail	
Channel	Channel 36	Frequency Range	30 MHz ~ 1 GHz
Input Power	120 Vac, 60 Hz	Detector Function	Peak (PK) Quasi-peak (QP)
Environmental Conditions	25 deg. C, 65 % RH	Tested By	Karl Lee

Antenna Polarity & Test Distance: Horizontal at 3 m										
Frequency (MHz)	Emission Level (dBuV/m)	Read Level (dBuV)	Limit (dBuV/m)	Margin (dB)	Antenna Factor (dB/m)	Cable Loss (dB)	Preamp Factor (dB)	Antenna Height (cm)	Table Angle (Degree)	Remark
47.28	28.74	45.55	40	-11.26	14.51	0.9	32.22	121	107	Peak
107.22	32.02	50.8	43.5	-11.48	12.19	1.28	32.25	198	164	Peak
184.17	36.81	57.33	43.5	-6.69	10.11	1.61	32.24	136	155	Peak
344.8	28.49	44.22	46	-17.51	14.15	2.19	32.07	183	167	Peak
708.1	24	33.64	46	-22	19.35	3.11	32.1	150	156	Peak
893.6	23.65	30.26	46	-22.35	21.42	3.49	31.52	147	168	Peak

Antenna Polarity & Test Distance: Vertical at 3 m										
Frequency (MHz)	Emission Level (dBuV/m)	Read Level (dBuV)	Limit (dBuV/m)	Margin (dB)	Antenna Factor (dB/m)	Cable Loss (dB)	Preamp Factor (dB)	Antenna Height (cm)	Table Angle (Degree)	Remark
47.01	30.51	47.32	40	-9.49	14.51	0.9	32.22	155	96	Peak
102.36	23.03	41.65	43.5	-20.47	12.36	1.28	32.26	161	134	Peak
201.72	37.05	56.6	43.5	-6.45	11.09	1.65	32.29	122	180	Peak
328.7	26.39	42.55	46	-19.61	13.75	2.19	32.1	147	152	Peak
540.8	22.53	35.05	46	-23.47	16.9	2.76	32.18	131	116	Peak
798.4	28.05	36.48	46	-17.95	20.31	3.32	32.06	100	245	Peak

Remarks:

- Emission Level = Read Level + Antenna Factor + Cable Loss - Preamp Factor
Margin value = Emission level – Limit value

4.2 Transmit Power Measurement

4.2.1 Limits of Transmit Power Measurement

Operation Band	EUT Category		Limit
U-NII-1		Outdoor Access Point	1 Watt (30 dBm) (Max. e.i.r.p \leq 125 mW (21 dBm) at any elevation angle above 30 degrees as measured from the horizon)
		Fixed point-to-point Access Point	1 Watt (30 dBm)
		Indoor Access Point	1 Watt (30 dBm)
	√	Mobile and Portable client device	250 mW (24 dBm)
U-NII-2A		√	250 mW (24 dBm) or 11 dBm + 10 log B*
U-NII-2C		√	250 mW (24 dBm) or 11 dBm + 10 log B*
U-NII-3		√	1 Watt (30 dBm)

*B is the 26 dB emission bandwidth in megahertz

Per KDB 662911 Method of conducted output power measurement on IEEE 802.11 devices,

Array Gain = 0 dB (i.e., no array gain) for $N_{ANT} \leq 4$;

Array Gain = 0 dB (i.e., no array gain) for channel widths ≥ 40 MHz for any N_{ANT} ;

Array Gain = $5 \log(N_{ANT}/N_{SS})$ dB or 3 dB, whichever is less for 20 MHz channel widths with $N_{ANT} \geq 5$.

For power measurements on all other devices: Array Gain = $10 \log(N_{ANT}/N_{SS})$ dB.

4.2.2 Test Setup

<Power Output Measurement>

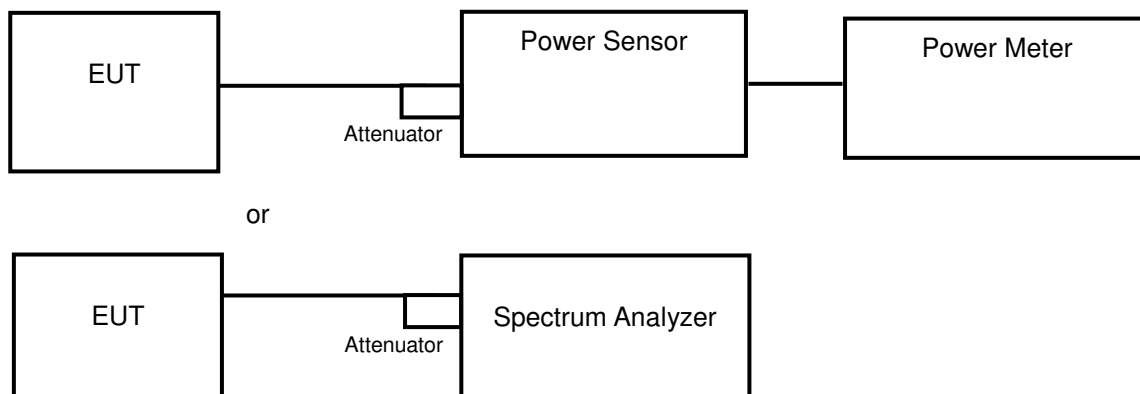

4.2.3 Test Instruments

Refer to section 4.1.2 to get information of above instrument.

4.2.4 Test Procedure

Average Power Measurement

<802.11a, 802.11n (HT20), 802.11n (HT40)>

Method PM is used to perform output power measurement, trigger and gating function of wide band power meter is enabled to measure max output power of TX on burst. Duty factor is not added to measured value.

<802.11ac (VHT80)>

Method SA-1 is used to perform output power measurement, trigger and gating function of spectrum analyzer is enabled to measure max output power of TX on burst. Duty factor is not added to measured value.

4.2.5 Deviation from Test Standard

No deviation.

4.2.6 EUT Operating Conditions

The software provided by client to enable the EUT under transmission condition continuously at lowest, middle and highest channel frequencies individually.

4.2.7 Test Result

Power Output:

802.11a

Channel	Frequency (MHz)	Maximum Conducted Power (dBm)	
		Chain 0	Chain 1
36	5180	17.67	17.83
44	5220	19.61	19.88
48	5240	19.64	19.89
52	5260	19.72	19.85
60	5300	19.64	19.85
64	5320	16.64	16.91
100	5500	17.52	17.78
116	5580	19.72	19.94
140	5700	16.58	16.77
149	5745	19.62	19.83
157	5785	19.64	19.86
165	5825	19.74	19.85

802.11n (HT20)

Channel	Frequency (MHz)	Maximum Conducted Power (dBm)		Total Power (mW)	Total Power (dBm)
		Chain 0	Chain 1		
36	5180	12.57	12.77	36.98	15.68
44	5220	15.57	15.89	74.82	18.74
48	5240	15.74	15.87	76.21	18.82
52	5260	15.68	15.74	74.47	18.72
60	5300	15.61	15.79	74.30	18.71
64	5320	9.55	9.89	18.75	12.73
100	5500	12.61	13.10	38.64	15.87
116	5580	15.67	15.74	74.47	18.72
140	5700	11.88	12.05	31.48	14.98
149	5745	15.86	16.08	79.07	18.98
157	5785	15.89	15.98	78.52	18.95
165	5825	15.72	16.10	77.98	18.92

802.11n (HT40)

Channel	Frequency (MHz)	Maximum Conducted Power (dBm)		Total Power (mW)	Total Power (dBm)
		Chain 0	Chain 1		
38	5190	8.43	8.76	14.49	11.61
46	5230	15.45	15.87	73.79	18.68
54	5270	15.82	15.98	77.80	18.91
62	5310	7.47	8.36	12.45	10.95
102	5510	9.76	9.93	19.32	12.86
110	5550	14.76	14.86	60.53	17.82
134	5670	13.70	14.11	49.20	16.92
151	5755	14.50	14.68	57.54	17.60
159	5795	14.65	14.78	59.29	17.73

802.11ac (VHT80)

Channel	Frequency (MHz)	Maximum Conducted Power (dBm)		Total Power (mW)	Total Power (dBm)
		Chain 0	Chain 1		
42	5210	6.56	7.14	9.71	9.87
58	5290	5.25	6.34	7.66	8.84
106	5530	7.43	8.22	12.16	10.85
122	5610	13.38	13.75	45.50	16.58
155	5775	13.19	13.65	44.06	16.44

5 Pictures of Test Arrangements

Please refer to the attached file (Test Setup Photo).

Annex A- Radiated Out of Band Emisison (OOBE) Measurement (For U-NII-3 band)

802.11a

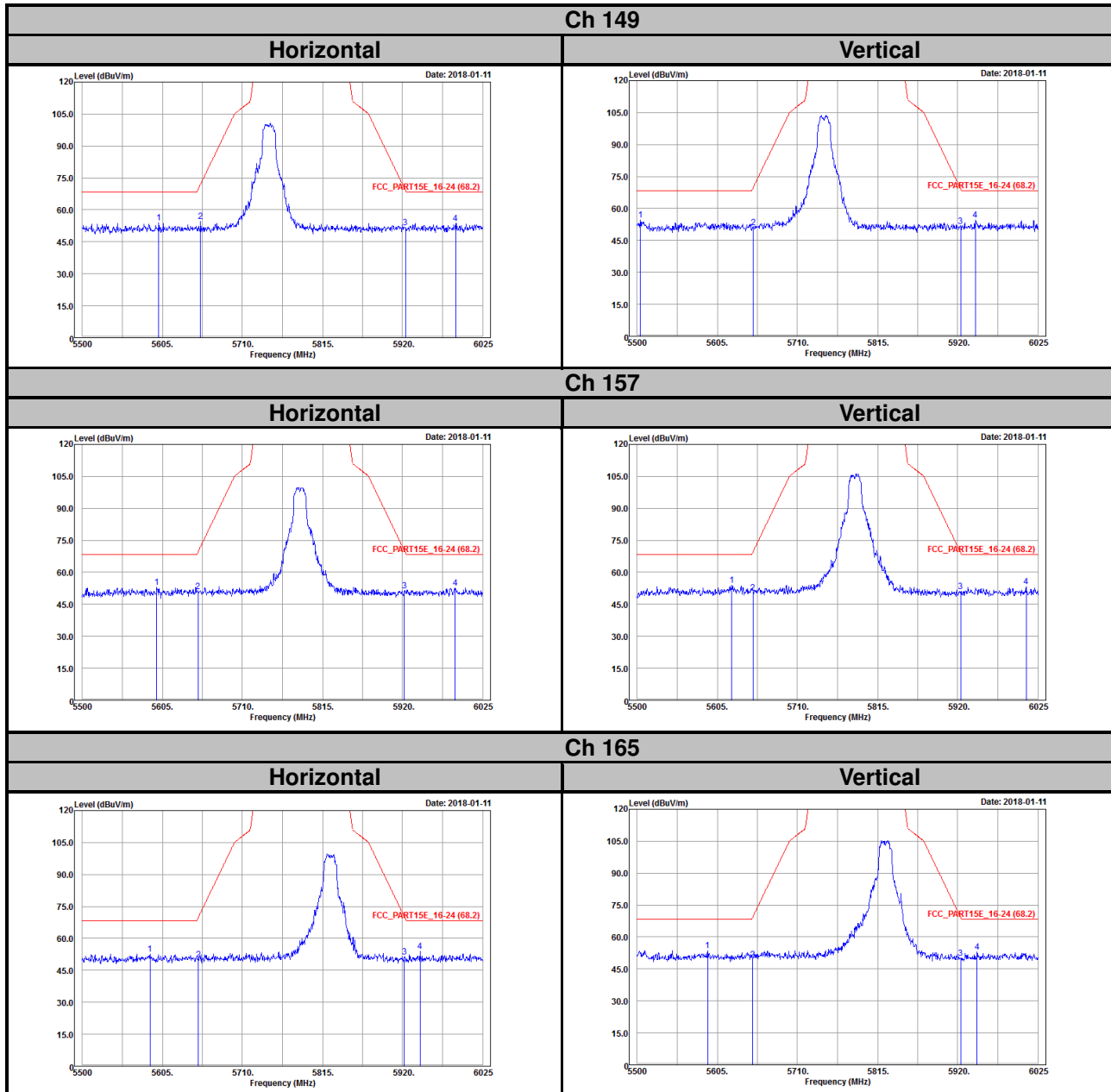

802.11n (HT20)

Ch 149

Horizontal

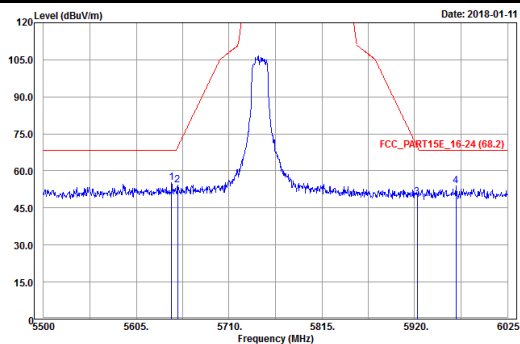

Vertical

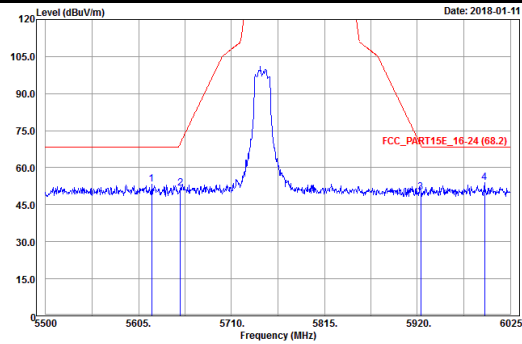

Ch 157

Horizontal

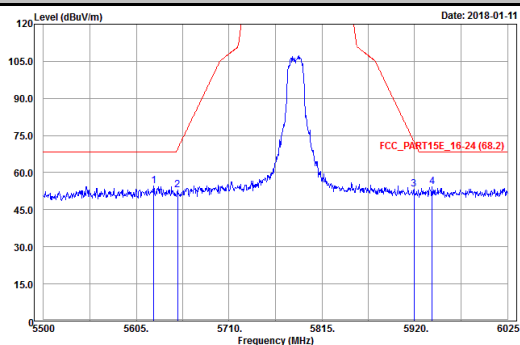

Vertical

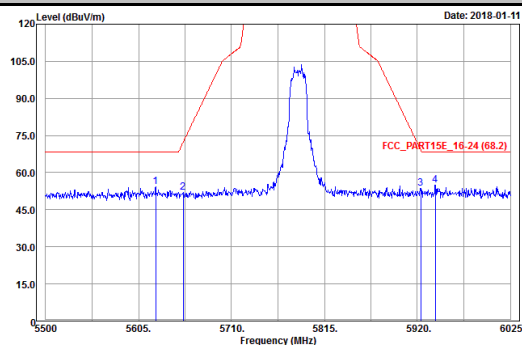

Ch 165

Horizontal

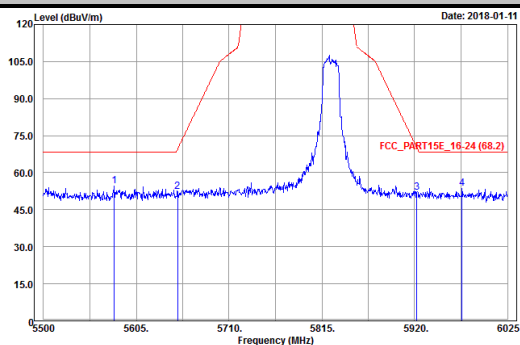

Vertical

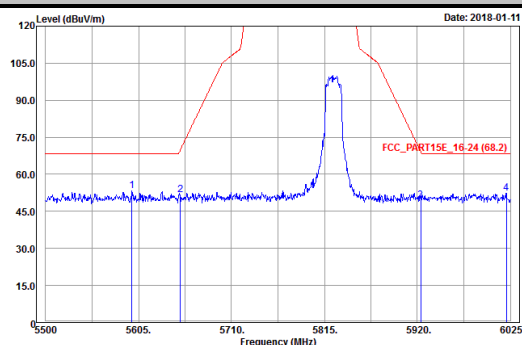

802.11n (HT40)

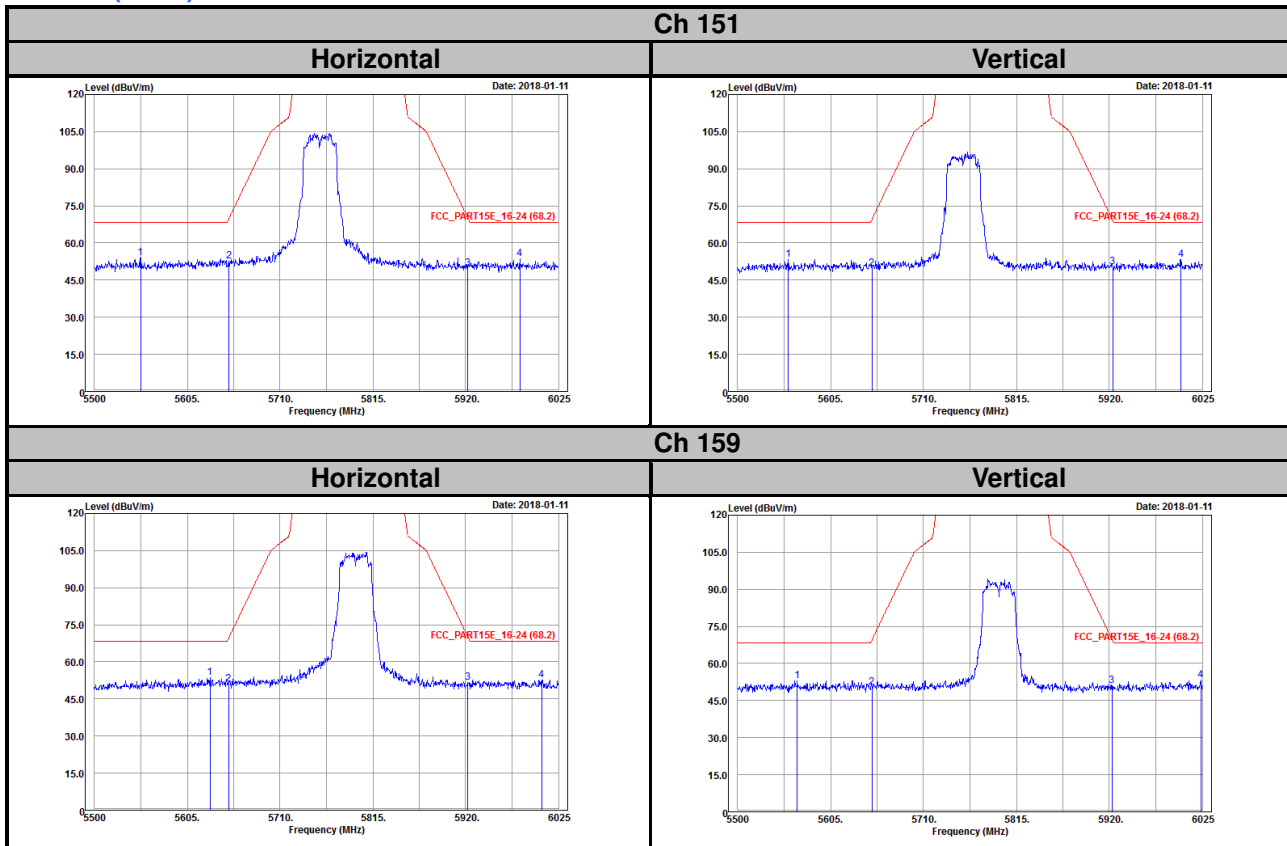

802.11ac (VHT80)

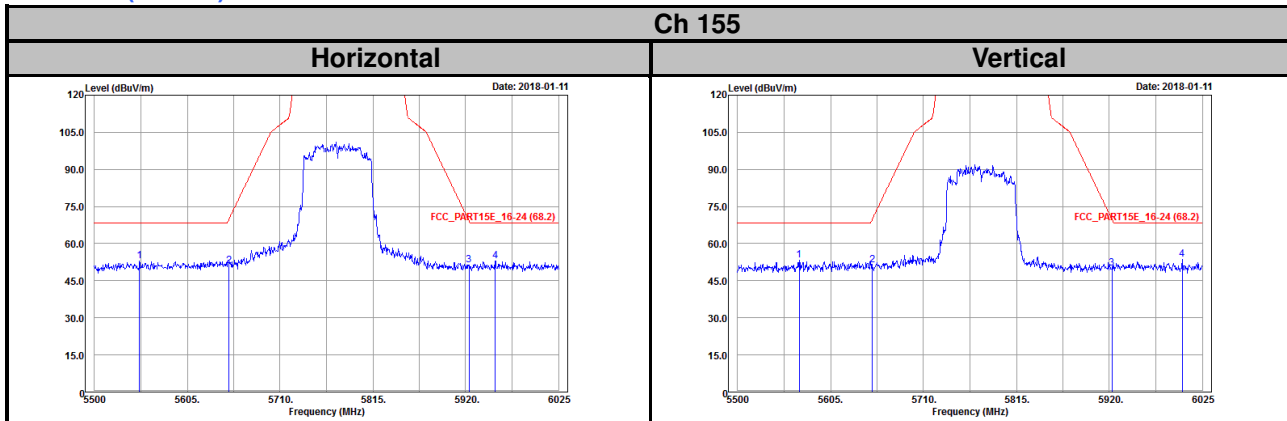

Appendix – Information on the Testing Laboratories

We, Bureau Veritas Consumer Products Services (H.K.) Ltd., Taoyuan Branch, were founded in 1988 to provide our best service in EMC, Radio, Telecom and Safety consultation. Our laboratories are FCC recognized accredited test firms and accredited according to ISO/IEC 17025.

If you have any comments, please feel free to contact us at the following:

Linko EMC/RF Lab

Tel: 886-2-26052180

Fax: 886-2-26051924

Hsin Chu EMC/RF/Telecom Lab

Tel: 886-3-6668565

Fax: 886-3-6668323

Hwa Ya EMC/RF/Safety

Tel: 886-3-3183232

Fax: 886-3-3270892

Email: service.adt@tw.bureauveritas.com

Web Site: www.bureauveritas-adt.com

The address and road map of all our labs can be found in our web site also.

--- END ---