



America

**Choose certainty.
Add value.**

Limited Report On

Application for Class II Permissive Change of the
DICKEY-John, Corp.

RVS III Radar Sensor, Model: 46783

FCC Part 15 Subpart C §15.245

IC RSS-210 Issue 8 December 2010

* Harmonic Emissions only

Report No. SD72120079-0916

September 2016



America

TÜV SÜD America Inc., 10040 Mesa Rim Road, San Diego, CA 92121
Tel: (858) 678-1400. Website: www.TUVamerica.com

REPORT ON Radio Testing of the
DICKY-John, Corp.
RVS III Radar Sensor

TEST REPORT NUMBER SD72120079-0916

PREPARED FOR DICKY-John, Corp.
5200 DICKY-John Road
Auburn, IL 62615

CONTACT PERSON Dr Barry C Mears
Senior Staff Engineer
(217) 438-2253
bmears@dickey-john.com

PREPARED BY 
Nikolay Shtin
Name
Authorized Signatory
Title: EMC/Wireless Test Engineer

APPROVED BY 
Juan Manuel Gonzalez
Name
Authorized Signatory
Title: Commercial/Wireless EMC Lab Manager

DATED September 26, 2016



America

TÜV SÜD America Inc., 10040 Mesa Rim Road, San Diego, CA 92121
Tel: (858) 678-1400. Website: www.TUVamerica.com

Revision History

SD72120079-0916 DICKY-John, Corp. RVS III Radar Sensor					
DATE	OLD REVISION	NEW REVISION	REASON	PAGES AFFECTED	APPROVED BY
09/26/16	Initial Release				Juan M. Gonzalez



CONTENTS

Section	Page No
1	REPORT SUMMARY5
1.1	Introduction.....6
1.2	Brief Summary of Results.....7
1.3	Product Information8
1.4	EUT Test configuration10
1.5	Deviations from the Standard.....12
1.6	Modification Record12
1.7	Test methodology.....12
1.8	Test facility location.....12
1.9	Test facility registration13
2	TEST DETAILS.....14
2.1	Field Strength Limits for Fundamental and Harmonics15
3	TEST EQUIPMENT USED23
3.1	Test Equipment Used.....24
3.2	Measurement Uncertainty25
4	DIAGRAM OF TEST SETUP26
4.1	Radiated Emission Test Setup27
5	ACCREDITATION, DISCLAIMERS AND COPYRIGHT28
5.1	Accreditation, Disclaimers and Copyright29



SECTION 1

REPORT SUMMARY

Radio Testing of the
DICKEY-John, Corp.
RVS III Radar Sensor
Model: 46783



1.1 INTRODUCTION

The information contained in this report is intended to show limited verification of the DICKEY-John, Corp. Radar Velocity Sensor to the requirements of FCC Part 15 Subpart C §15.245 and IC RSS-210 Issue 8 December 2010.

Objective	To perform Class II Permissive Change Verification to determine the Equipment Under Test's (EUT's) compliance with the Test Specification, for the series of tests carried out. The EUT is being assessed due to a change in the antenna feeding waveguide.
Manufacturer	DICKEY-John, Corp.
Product Name	RVSIII
Model Number(s)	46783
FCC ID Number	B7JDJCRVSIII
IC Number	5682A-DJCRVSIII
Serial Number(s)	N/A
Number of Samples Tested	1
Test Specification/Issue/Date	<ul style="list-style-type: none">• FCC Part 15 Subpart C §15.245 (October 1, 2015).• RSS-210 – License-exempt Radio Apparatus (All Frequency Bands): Category I Equipment (Issue 8, December 2010).
Start of Test	September 16, 2016
Finish of Test	September 16, 2016
Name of Engineer(s)	Nikolay Shtin
Related Document(s)	None. Supporting documents for EUT certification are separate exhibits.



1.2 BRIEF SUMMARY OF RESULTS

A brief summary of the tests carried out in accordance with FCC Part 15 Subpart C §15.245 with cross-reference to the corresponding ISED RSS standard is shown below.

Section	Spec Clause	RSS	Test Description	Result	Comments/Base Standard
-		RSS-Gen 4.6.1	99% Emission Bandwidth	N/A	
-	§15.245(b)	RSS-210 A7.1(1)	Field Strength Limits for Fundamental Emissions	N/A	
2.1	§15.245(b)(1)	RSS-210 A7.1(2)(3)	Harmonic Emissions	Compliant	
-	§15.245(b)(3)	RSS-210 A7.1(4)	Spurious Radiated Emissions	N/A	

N/A Not performed. Results under this section are covered by the original Report Number: SD72107714-0715B FCC Part 15 Subpart C §15.245 and IC RSS-210 Issue 8 Test Report for DICKEY-John Corp. RVS III Radar Sensor issued by TÜV SÜD America Inc.

1.3 PRODUCT INFORMATION

1.3.1 Technical Description

The Equipment Under Test (EUT) was a DICKEY-John, Corp. Radar Velocity Sensor, Model 46783 as shown in the photograph below. The EUT is a third-generation ground speed sensor. The EUT operates on 24.125 GHz nominal frequency in the 24.075-24.175 GHz band.

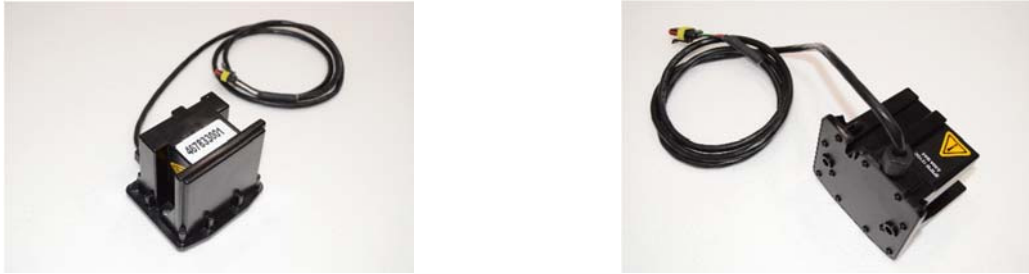

Equipment Under Test

1.3.2 Customer declaration of the changes:

We have inserted a harmonic filter plate (part 6) between the transceiver and the antenna waveguide. What we have found is that we get better signal to noise at our mixing diode if we extend the waveguide slightly. We would accomplish this by adding four spacer plates (part 7) between the transceiver and antenna waveguide, keeping the harmonic filter.

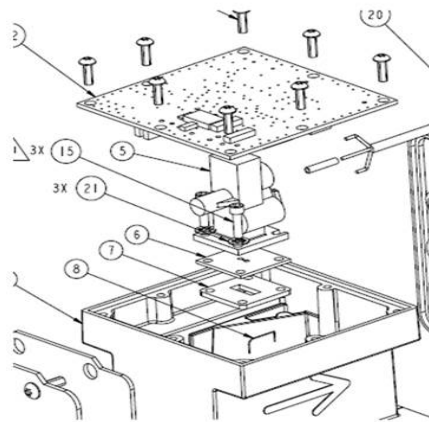

Increasing the waveguide length doesn't impact our power output or antenna characteristics, it only repositions the peaks of the standing wave in the waveguide so that a peak occurs at our mixing diode. This improves our sensitivity to the returned signal. As an additional verification we have performed Harmonic testing with TUV SUD America (project #: SD72120079-0916 Dickey-John) and results are within specification.



1.3.3 EUT General Description

EUT Description	Radar Velocity Sensor
Product Name	RVS III Radar Sensor
Model Number(s)	46783
Rated Voltage	12.0 VDC
Output Power	125.2 dB μ V/m @ 3 meters
Frequency Range	24125 MHz in the 24075 MHz to 24175 MHz Band
Number of Operating Frequencies	1
Channels Verified	24125 MHz
Antenna Type (used during evaluation)	Integral (Complies with Part 15.203 requirements)

1.3.4 Antenna Details

Manufacturer	Dickey-john Corp.
Antenna Type	Planar array antenna
Antenna Gain	23 dBi
EUT Antenna Connector	N/A .
Maximum Dimensions	3.4" H x 3.325" W x 0.02" T

1.4 EUT TEST CONFIGURATION

1.4.1 Test Configuration Description

Test Configurations	Description
Default	Radiated only configuration. EUT transmitting through the integral antenna.

1.4.2 EUT Exercise Software

No test firmware is required.

1.4.3 Support Equipment and I/O cables

No support equipment is required.

1.4.4 Worst Case Configuration

For radiated measurements X and Y orientations were verified. Identical result obtained between these two orientations Verification performed using X orientation.

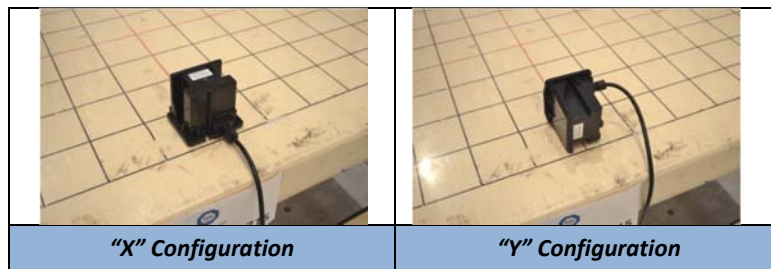

1.4.5 Simplified Test Configuration Diagram

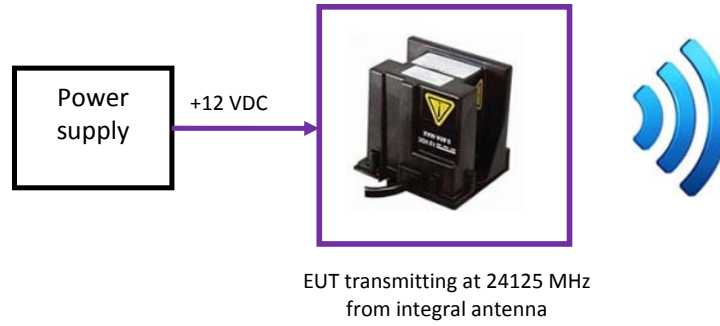

For Illustration Purpose Only
Image presented may not represent the
actual EUT or support equipment



1.5 DEVIATIONS FROM THE STANDARD

No deviations from the applicable test standards or test plan were made during testing.

1.6 MODIFICATION RECORD

Description of Modification	Modification Fitted By	Date Modification Fitted
Serial Number N/A		
N/A		

The table above details modifications made to the EUT during the test programme. The modifications incorporated during each test (if relevant) are recorded on the appropriate test pages.

1.7 TEST METHODOLOGY

All measurements contained in this report were conducted with ANSI C63.10-2013, American National Standard of Procedures for Compliance Testing of Unlicensed Wireless Devices. For radiated emissions the equipment under test (EUT) was configured to measure its highest possible emission level. The test modes were adapted according to the Operating Instructions provided by the manufacturer/client.

1.8 TEST FACILITY LOCATION

1.8.1 TÜV SÜD America Inc. (Mira Mesa)

10040 Mesa Rim Road, San Diego, CA 92121-2912 (32.901268,-117.177681). Phone: 858 678 1400 FAX: 858-546 0364

1.8.2 TÜV SÜD America Inc. (Rancho Bernardo)

16530 Via Esprillo, San Diego, CA 92127-1708 (33.018644,-117.092409). Phone: 858 942 5542 FAX: 858-546 0364



1.9 TEST FACILITY REGISTRATION

1.9.1 FCC – Registration No.: US1146

TUV SUD America Inc. (San Diego), is an accredited test facility with the site description report on file and has met all the requirements specified in §2.498 of the FCC rules. The acceptance letter from the FCC is maintained in our files and the Registration is US1146.

1.9.2 Innovation, Science and Economic Development Canada Registration No.: 3067A

The 10m Semi-anechoic chamber of TUV SUD America Inc. (San Diego) has been registered by Certification and Engineering Bureau of Innovation, Science and Economic Development Canada for radio equipment testing with Registration No. 3067A.



SECTION 2

TEST DETAILS

Radio Testing of the
DICKEY-John, Corp.
RVS III Radar Sensor
Model: 46783



2.1 FIELD STRENGTH LIMITS FOR HARMONICS

2.1.1 Specification Reference

Part 15 Subpart C §15.245(a)

2.1.2 Standard Applicable

(b) The field strength of emissions from intentional radiators operated within these frequency bands shall comply with the following:

Fundamental frequency	Field strength of fundamental (millivolts/meter)	Field strength of harmonics (millivolts/meter)
902–928 MHz	500	1.6
2400–2483.5 MHz	500	1.6
5725–5875 MHz	500	1.6
10500–10550 MHz	2500	25
24075–24175 MHz	2500	25

(1) Regardless of the limits shown in the above table, harmonic emissions in the restricted bands below 17.7 GHz, as specified in § 15.205, shall not exceed the field strength limits shown in § 15.209. Harmonic emissions in the restricted bands at and above 17.7 GHz shall not exceed the following field strength limits:

- (i) For the second and third harmonics of field disturbance sensors operating in the 24075-24175 MHz band and for other field disturbance sensors designed for use only within a building or to open building doors, 25.0 mV/m.
- (ii) For all other field disturbance sensors, 7.5 mV/m.
- (iii) Field disturbance sensors designed to be used in motor vehicles or aircraft must include features to prevent continuous operation unless their emissions in the restricted bands, other than the second and third harmonics from devices operating in the 24075-24175 MHz band, fully comply with the limits given in § 15.209. Continuous operation of field disturbance sensors designed to be used in farm equipment, vehicles such as forklifts that are intended primarily for use indoors or for very specialized operations, or railroad locomotives, railroad cars and other equipment which travels on fixed tracks is permitted. A field disturbance sensor will be considered not to be operating in a continuous mode if its operation is limited to specific activities of limited duration (e.g., putting a vehicle into reverse gear, activating a turn signal, etc.).

2.1.3 Equipment Under Test and Modification State

Serial No: N/A / Default Test Configuration

2.1.4 Date of Test/Initial of test personnel who performed the test

September 16, 2016/NS

2.1.5 Test Equipment Used

The major items of test equipment used for the above tests are identified in Section 3.1.



2.1.6 Environmental Conditions/ Test Location

Test performed at TÜV SÜD America Inc. Rancho Bernardo facility

Ambient Temperature 26.2°C
Relative Humidity 44.4%
ATM Pressure 98.9 kPa

2.1.7 Additional Observations

- This is a radiated test. The spectrum was searched up to 4th harmonic (96.7 GHz).
- The 2nd and 3rd harmonics emissions were evaluated at 3 m distance. For the 4th harmonic measurements, test distance was reduced to 1.5 m to assure that the noise floor is below the applicable limit.
- Corrections factor of 6 dB was used to extrapolate the field strength measured at 1.5 metres to the 3 meters distance as specified in § 15.31.

2.1.8 Test Results

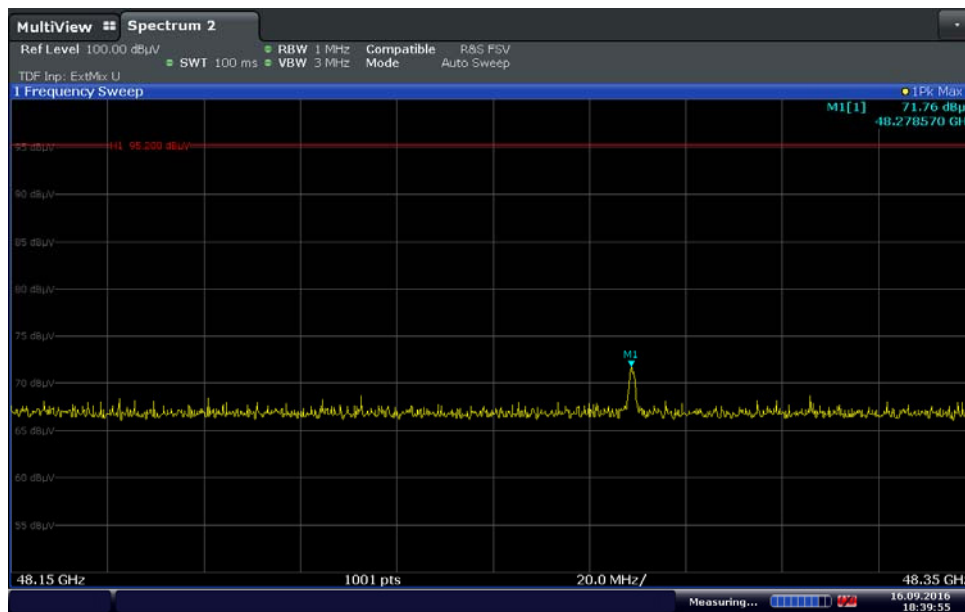

18:39:56 16.09.2016

2nd Harmonic (Peak detector)

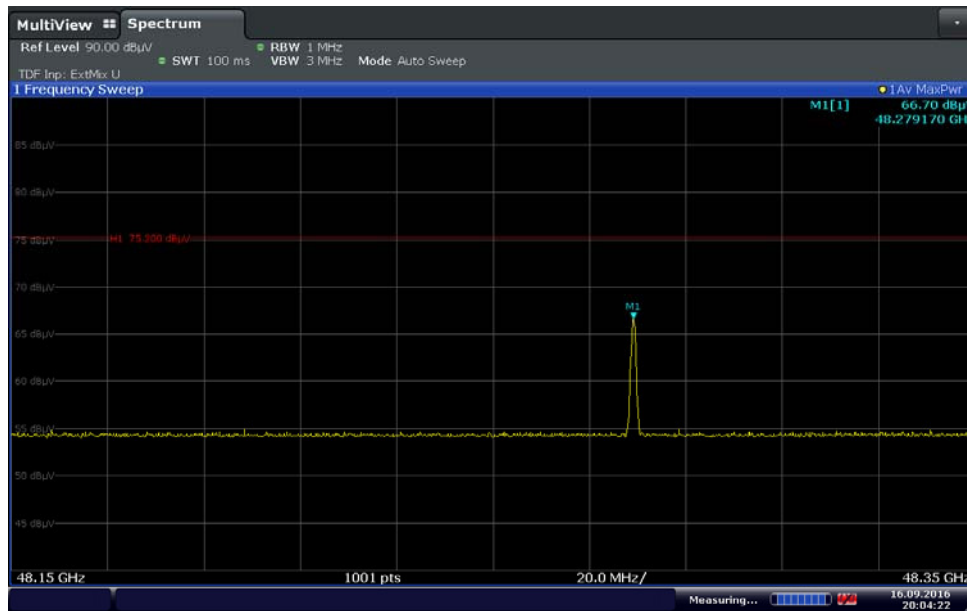

20:04:22 16.09.2016

2nd Harmonic (Average detector)

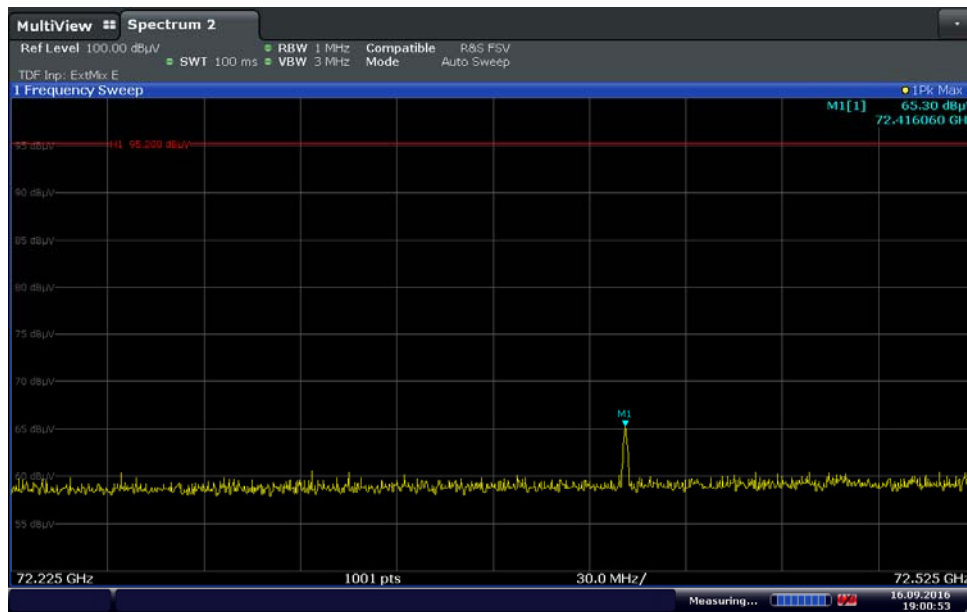

19:00:53 16.09.2016

3rd Harmonic (Peak detector)

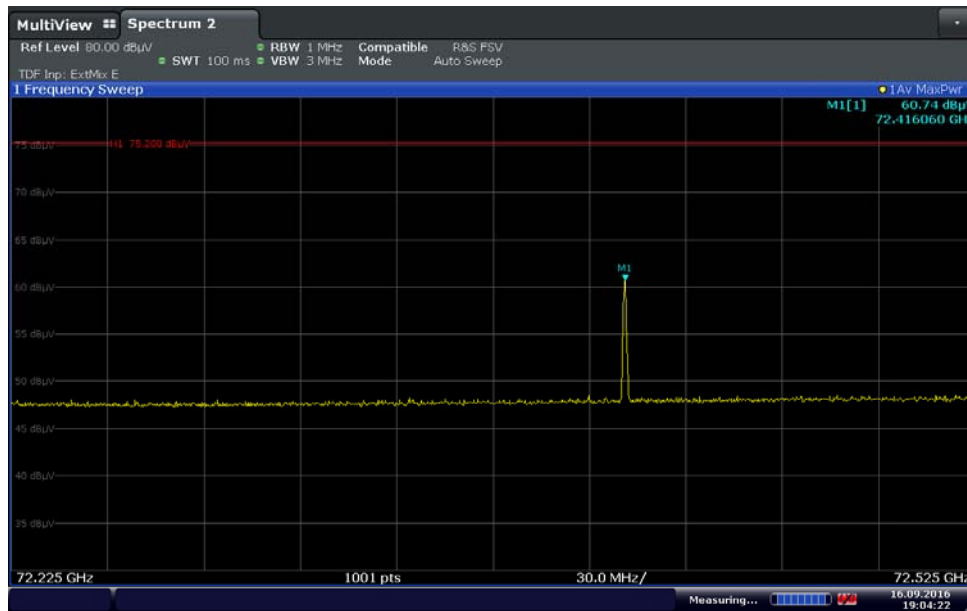

19:04:23 16.09.2016

3rd Harmonic (Average detector)

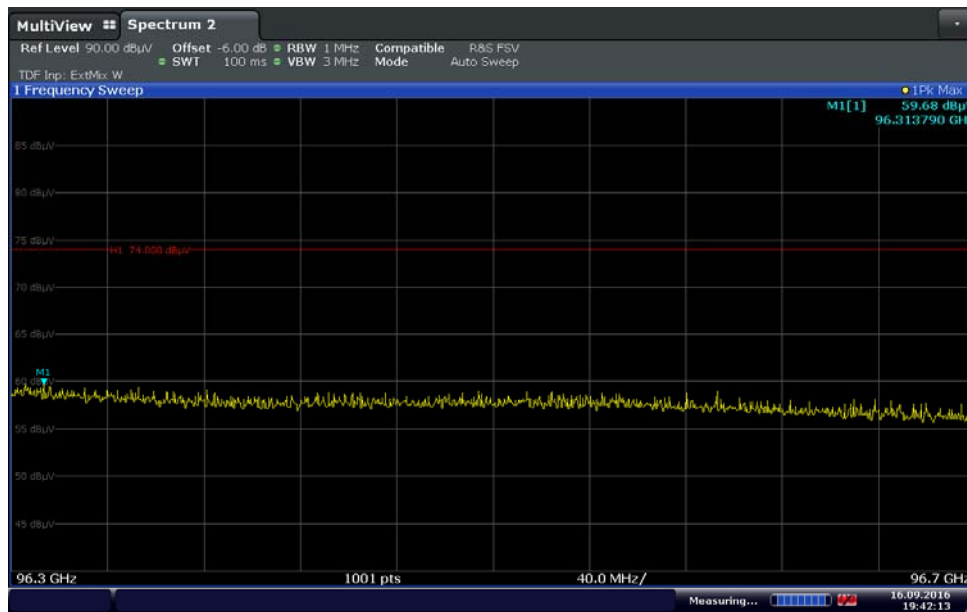

19:42:14 16.09.2016

4th Harmonic (Peak detector)

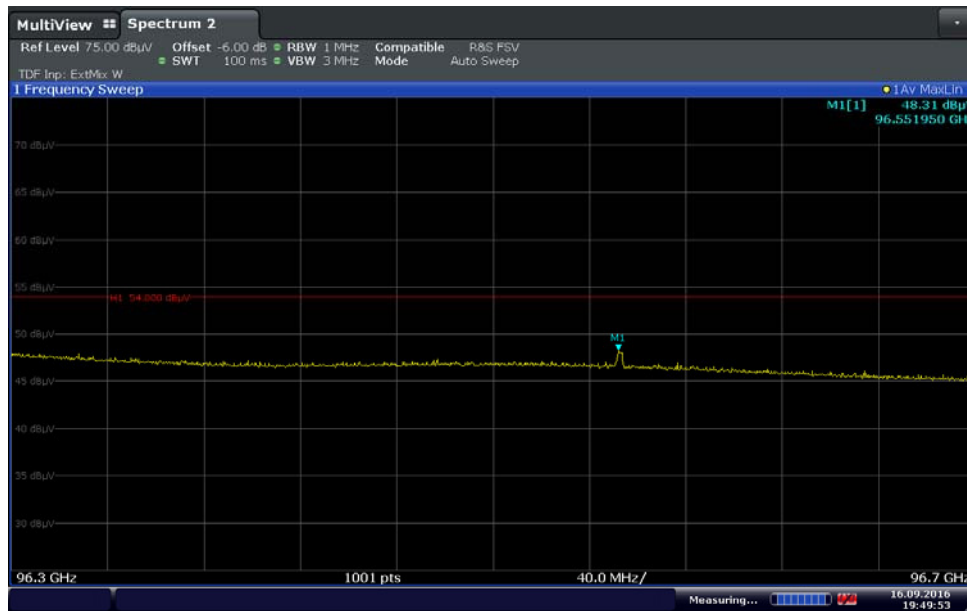

19:49:54 16.09.2016

4th Harmonic (Peak detector)

2.1.9 Test Setup Photo (2nd harmonic)

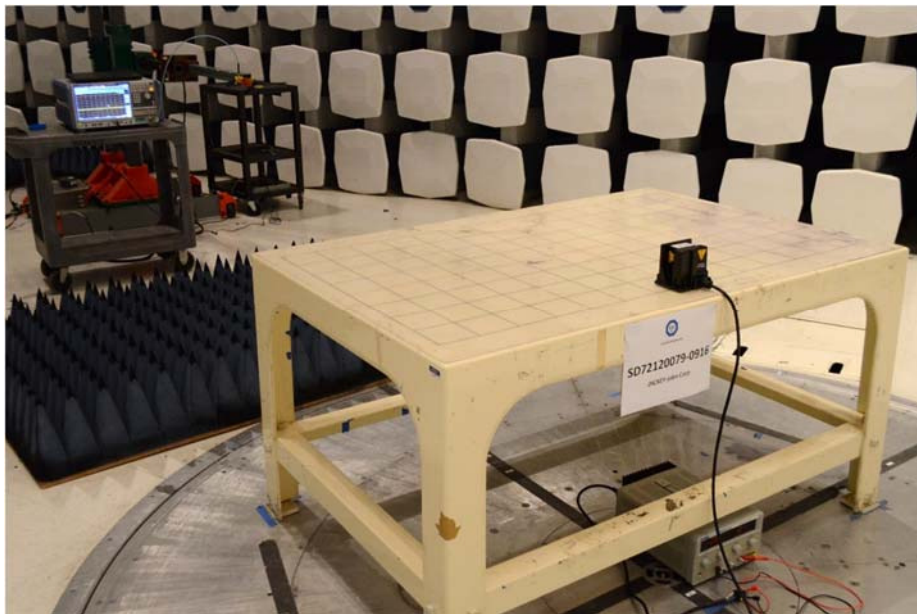
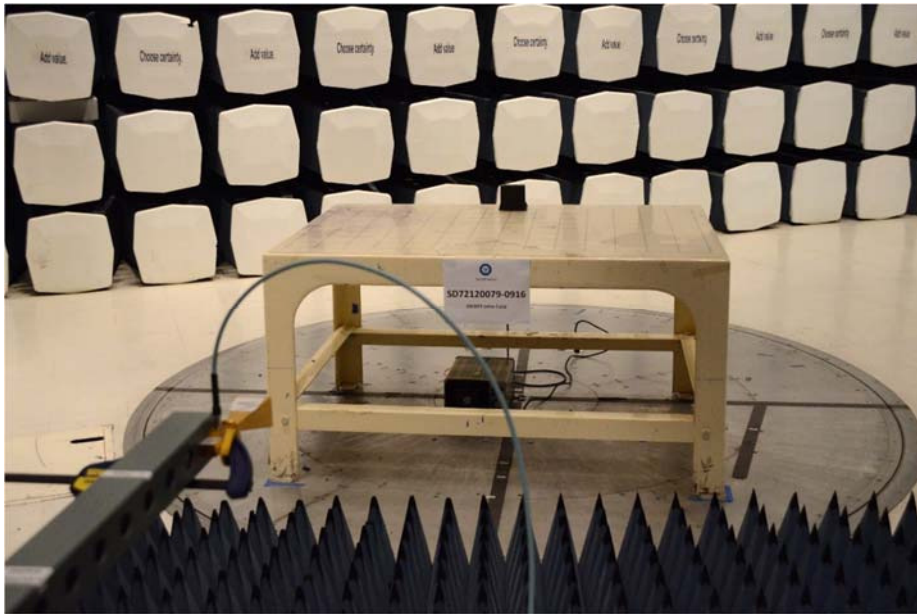

2.1.10 Test Setup Photo (3rd harmonic)

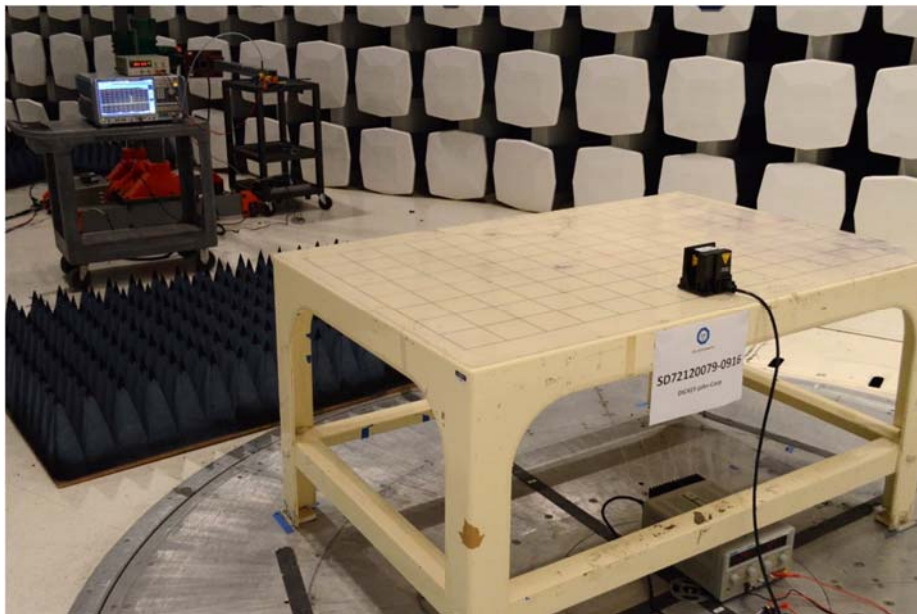
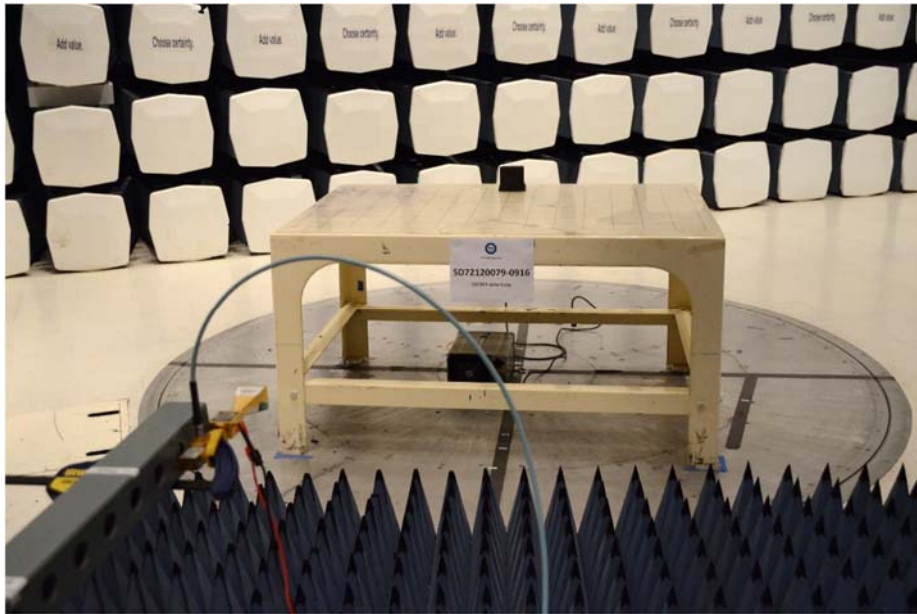

2.1.11 Test Setup Photo (4th harmonic)

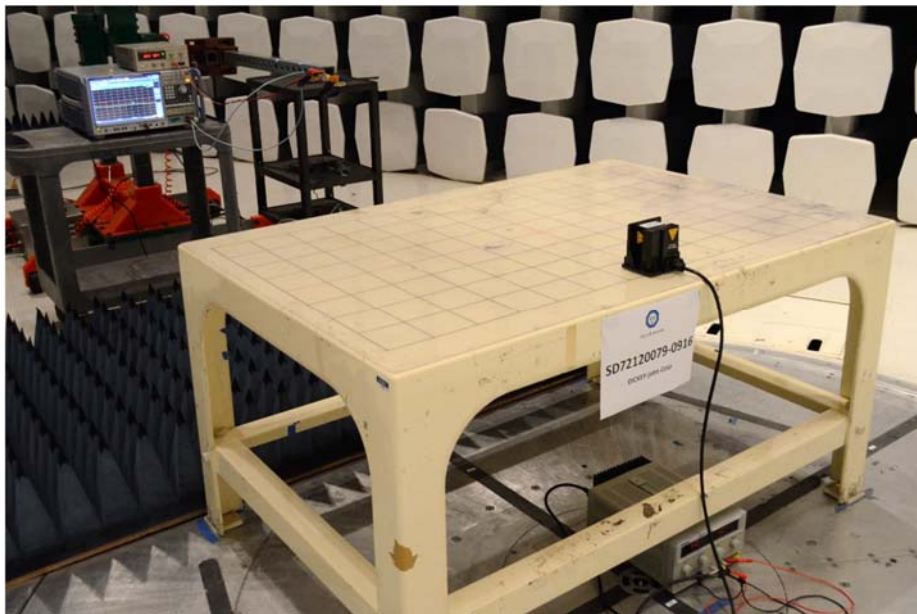
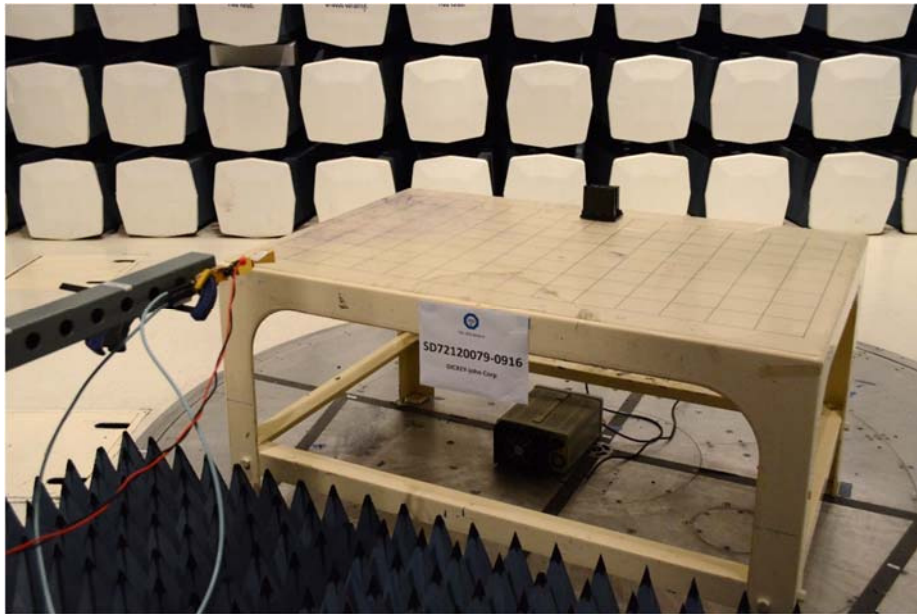



SECTION 3

TEST EQUIPMENT USED



3.1 TEST EQUIPMENT USED

List of absolute measuring and other principal items of test equipment.

ID Number (SDGE/SDRB)	Test Equipment	Type	Serial Number	Manufacturer	Cal Date	Cal Due Date
Radiated Test Setup						
1003	Signal Generator	SMR-40	1104.0002.40	Rhode & Schwarz	05/16/16	05/16/17
7611	Signal/Spectrum Analyzer	FSW26	102017	Rhode & Schwarz	02/01/16	02/01/17
9003	Horn antenna (40-60 GHz)	HO19R	103	Custom Microwaves	04/18/2016	04/18/17
9004	Horn antenna (50-75 GHz)	HO15R	104	Custom Microwaves	04/18/2016	04/18/17
9005	Horn antenna (75-110 GHz)	HO10R	105	Custom Microwaves	04/27/2016	04/27/17
8892	Pre-amplifier (50-75 GHz)	SBL-5037533050-1515-E1	12020-01	Sage Millimeter, Inc.	Verified	
8912	Pre-amplifier (75-110 GHz)	FLNA-10-0005	FTL10839	Farran Technology Ltd.	Verified	
7637	Harmonic mixer (40-60 GHz)	FS-Z60	100009	Rhode & Schwarz	01/26/16	01/26/18
7636	Harmonic mixer (60-90 GHz)	FS-Z90	100092	Rhode & Schwarz	10/26/15	10/26/17
7633	Harmonic mixer (75-110 GHz)	HM-110-7	101000	Radiometer Physics	Verified	
8872	Direct Reading Attenuator	STA-60-19-D1	11875-01	Sage Millimeter, Inc.	Verified	
8860	Direct Reading Attenuator	STA-60-15-D1	11466-01	Sage Millimeter, Inc.	Verified	
8861	Direct Reading Attenuator	STA-60-10-D1	11466-01	Sage Millimeter, Inc.	Verified	
8873	Active Multiplier (40-60 GHz)	AMC-19-RFH00	124	Millitech, Inc.	Verified	
8914	Active Multiplier (50-75 GHz)	AMC-15-RFH00	283	Millitech, Inc.	Verified	
8915	Active Multiplier (75-110 GHz)	AMC-10-RFH00	606	Millitech, Inc.	Verified	
Miscellaneous						
6792	Multimeter	3478A	2911A70964	Hewlett Packard	08/29/16	08/29/17
11312	Mini Environmental Quality Meter	850027	CF099-56010-340	Sper Scientific	04/09/16	04/09/17
118208	DC Power Supply	Pad 250-4.5L	29051058	Kikusui Electronics Corp.	Verified by 6792	



3.2 MEASUREMENT UNCERTAINTY

For a 95% confidence level, the measurement uncertainties for defined systems are:

3.2.1 Radiated Emission Measurements

Contribution		Probability Distribution Type	Probability Distribution x_i	Standard Uncertainty $u(x_i)$	$[u(x_i)]^2$
1	Spectrum Analyzer/External Mixer	Rectangular	3.34	1.93	3.72
2	Cables	Rectangular	0.70	0.40	0.16
3	Preamp	Rectangular	0.50	0.29	0.08
4	Antenna	Rectangular	2.70	1.56	2.43
6	EUT Setup	Rectangular	1.50	0.87	0.75
Combined Uncertainty (u_c):					2.67
Coverage Factor (k):					2
Expanded Uncertainty:					5.35



SECTION 4

DIAGRAM OF TEST SETUP

4.1 RADIATED EMISSION TEST SETUP

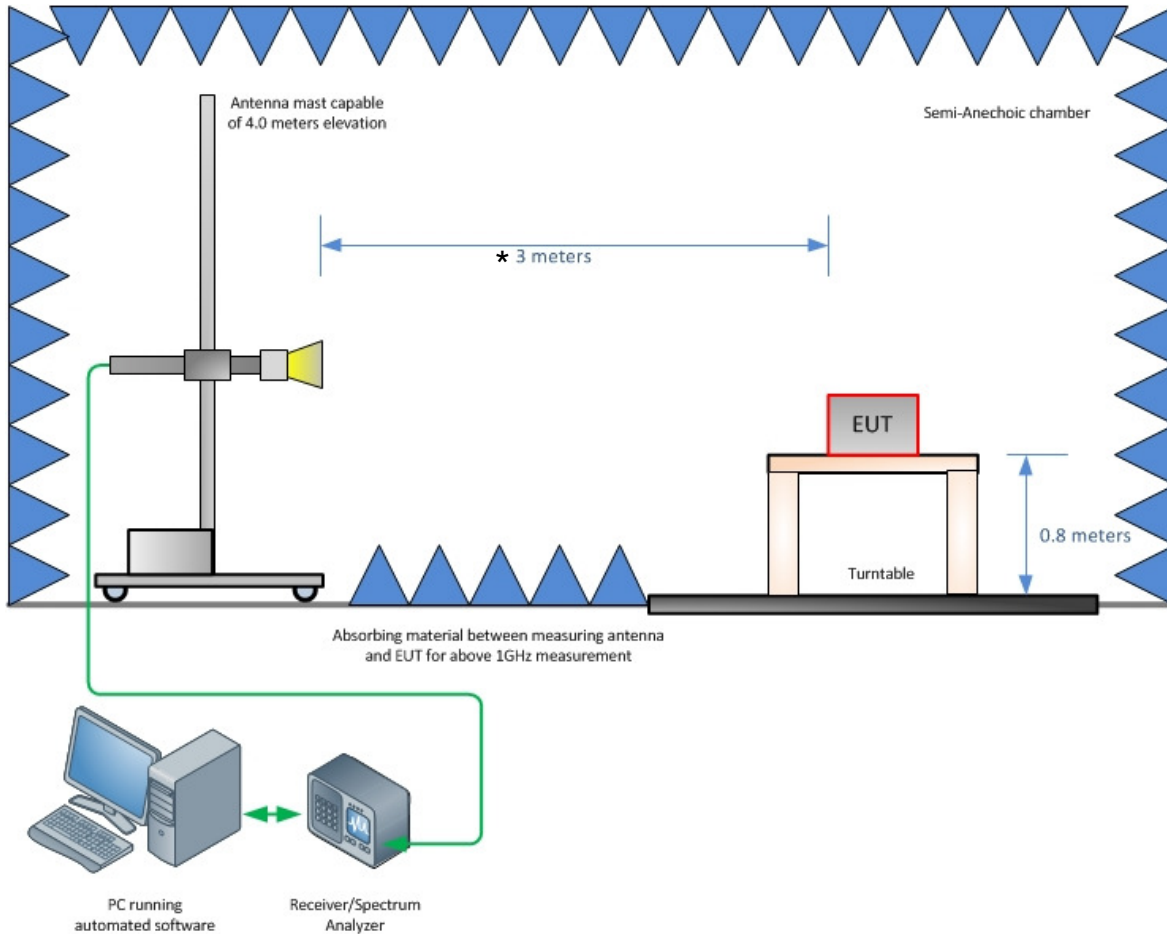

*A test distance of 3 m was used for measurements below 75 GHz. The emissions in the range from 75 GHz to 110 GHz were evaluated at 1.5 m distance to assure that the noise floor is below the applicable limit.



SECTION 5

ACCREDITATION, DISCLAIMERS AND COPYRIGHT



5.1 ACCREDITATION, DISCLAIMERS AND COPYRIGHT

TÜV SÜD America Inc.'s reports apply only to the specific sample tested under stated test conditions. It is the manufacturer's responsibility to assure the continued compliance of production units of this model. TÜV SÜD America, Inc. shall have no liability for any deductions, inferences or generalizations drawn by the client or others from TÜV SÜD America, Inc.'s issued reports.

This report is the confidential property of the client. As a mutual protection to our clients, the public and TÜV SÜD America, Inc., extracts from the test report shall not be reproduced, except in full without TÜV SÜD America, Inc.'s written approval.

This report must not be used to claim product certification, approval, or endorsement by A2LA, NIST, or any agency of the federal government.

TÜV SÜD America, Inc. and its professional staff hold government and professional organization certifications for AAMI, ACIL, AEA, ANSI, IEEE, A2LA, NIST and VCCI.



A2LA Cert. No. 2955.13

