



RADAR III SENSOR

COMPLIANCE

This equipment has been tested and found to comply with the limits for a Class B digital device pursuant to part 15 of the FCC Rules. These limits are designed to provide reasonable protection against harmful interference in a residential installation. This equipment generates, uses, and can radiate radio frequency energy and, if not installed and used in accordance with the instructions, may cause harmful interference to radio communications.

However, there is no guarantee that interference will not occur in a particular installation. If this equipment does cause harmful interference to radio or television reception which can be determined by turning the equipment off and on, the user is encouraged to try to correct the interference by one or more of the following measures:

- Reorient or relocate the receiving antenna
- Increase the separation between the equipment and receiver
- Connect the equipment into an outlet on a circuit different from that to which the receiver is connected
- Consult the dealer or an experienced radio/TV technician for help

DISCLAIMER

DICKEY-john reserves the right to make engineering refinements or procedural changes that may not be reflected in this manual. Material included in this manual is for informational purposes and is subject to change without notice.

INSTALLATION INSTRUCTIONS



INSTALLATION INSTRUCTIONS



RADAR III SENSOR

IMPORTANT: Changes or modifications to the RVS ground speed sensor not expressly approved by DICKEY-john Corporation could void the user's authority to operate the equipment.

The RVS III Radar Sensor is a streamlined sensor that views ground surface for accurate ground speed detection. High-tech planar array provides velocity measurement with velocity errors of less than or equal to 1-3% after infield calibration.

MOUNTING BRACKET KITS

Several mounting options are available with the RVS III Radar. Two bracket kits are available that meet most application requirements.

- A standard pipe mounting plate for use when the implement already has a 3/4" diameter pipe mount in a suitable location, and
- A mounting pipe kit to be used in combination with the standard pipe mounting plate.

NOTE: 2006 models of the Vibration Isolation Mount hardware kit use 1/4" hardware (kit 467830781)

RVS III RADAR SENSOR KIT

1. RVS III Radar Sensor
2. Installation Instruction
3. Vibration Isolation Mount Hardware Kit
 - Isolation Mounts (3)
 - 6 mm Nuts (6)
 - 6 mm Flat Lockwashers (6)
 - 6 mm Split Ring Lockwashers (6)

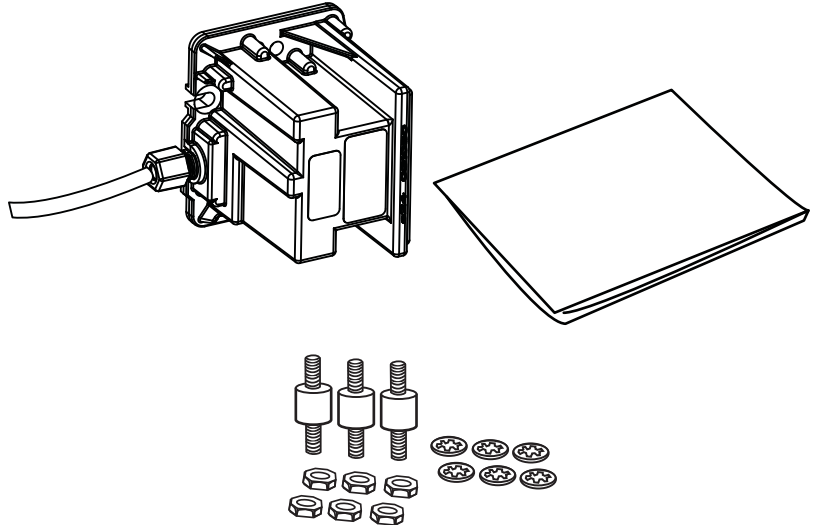

INSTALLATION INSTRUCTIONS



RVS III MOUNTING BRACKET KIT

1. Mounting Bracket
2. U-Bolts 1 1/8" x 2" x 1/4 - 20 (2)
3. 1/4" Split Ring Lock Washers (4)
4. 1/4 - 20 Nuts (4)

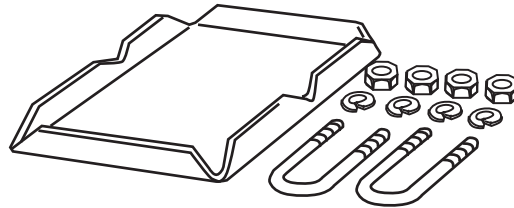

RVS III "L" PIPE MOUNTING BRACKET KIT

1. "L" Pipe Mounting Bracket
2. 3/8 - 16 x 1 1/2" Bolts (2)
3. 3/8 Split Ring Lock Washers (2)
4. 3/8 Nuts (2)

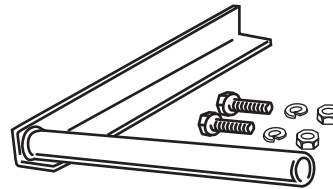

24V RVS III ADAPTER CABLE ASSEMBLY



INSTALLATION INSTRUCTIONS



MOUNTING

SELECT A MOUNTING LOCATION

1. Park the vehicle on level ground. This is necessary in order to install the radar at the proper angle with respect to the ground. Refer to Figure 1 for illustration.

NOTE: Rear facing orientation is the preferred mount for more physical protection of the radar, however, there can be instances where the radar orientation must face forward.

Figure 1

Proper Radar Placement

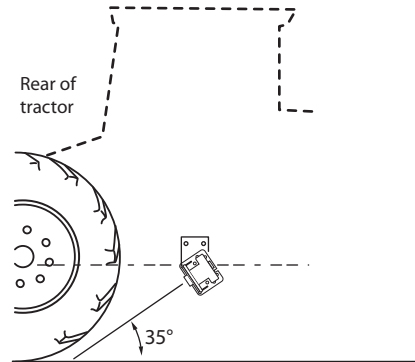

NOTE: The radar must have an unobstructed cone-shaped view of the ground. If a vehicle tire, hose, or liquid line is within the cone-shaped area, erroneous readings can result.

2. The following list describes some of the precautions that must be followed when selecting a mounting location.

- The face of the radar must have an unobstructed view of the ground. The area that must remain unobstructed is cone-shaped from the face of the radar to the ground, as illustrated in Figure 2. The pattern of the radar signal on the ground is oval-shaped due to the installation angle. The size of the oval pattern is dependent on the radar height above ground.

Figure 2

Unobstructed Mounting Location

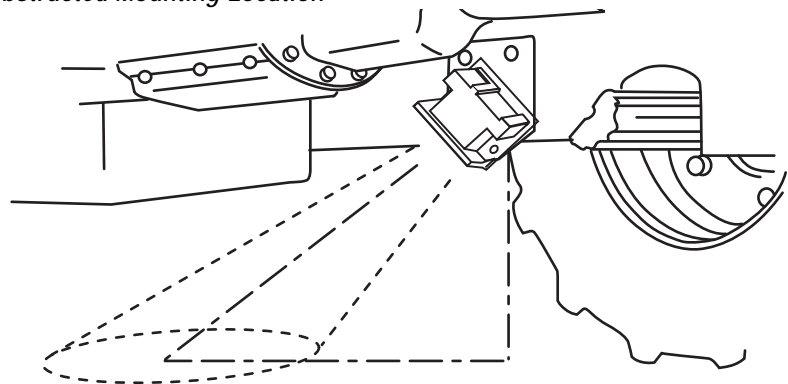

INSTALLATION INSTRUCTIONS



Following is the pattern size for the indicated height.

RADAR HEIGHT	PATTERN SIZE (OVAL)
18 inches	18.8 x 12.7 inches
24 inches	24.17 x 17.2 inches
48 inches	31.0 x 25.6 inches

- Fluids must not drip on radar face area.
- Ensure that radar is away from all heat sources.
- The radar face housing must not touch the vehicle.
- Keep radar away from stubble and debris.
- It is recommended that the radar be installed facing the rear of the vehicle.
- The radar mounting location can have a minimal amount of vibration; however, excessive vibration can cause erroneous MPH readings with the vehicle stationary.

NOTE: The most critical dimensions are the placement of the three Radar III sensor mounting holes. These holes can be oveled out if they are not drilled in the exact location.

IMPORTANT: Operational vibration limits (with isolation mounts) are 0.75 grms from 200 Hz - 350 Hz and 3 grms from 351 Hz - 2000 Hz.

*Figure 3
Radar Placement*

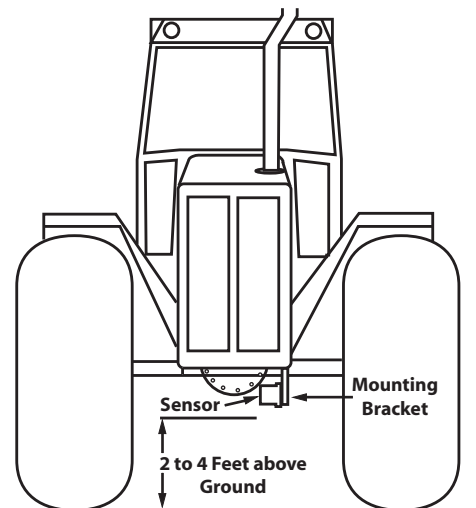

INSTALLATION INSTRUCTIONS



PIPE MOUNTING BRACKET KIT

The Pipe Mounting Bracket Kit consists of a mounting plate and two U-bolts with lock washers and nuts. This kit is used to install the Radar on the “L” pipe mounting bracket per Figure 4. If the pipe mounting bracket is already installed, proceed to step 3; otherwise continue as follows.

Figure 4

Typical Pipe Mounting Locations

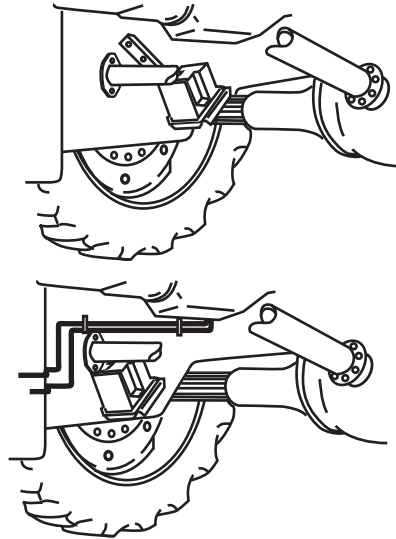

1. Select a location (on the inside of the main frame, when possible) to install the radar “L” pipe mounting bracket. If possible, select a location where two existing bolts can be used and drill matching holes in the angle iron on the pipe mounting bracket. Figure 4 shows some typical mounting positions.
2. If two existing bolts are not at the selected location, drill two holes in the mounting surface and two matching holes in the angle iron on the pipe mounting bracket (check the opposite side of the drilling surface for wires, hoses, etc.). Before installing the pipe mounting bracket, ensure the radar can be positioned over the pipe extending from the bracket. If not, the radar will have to be installed on the pipe before the mounting bracket is secured to the mounting surface.

NOTE: Operational vibration limits (with isolation mounts) are 0.75 grms from 200 Hz - 350 Hz and 3 grms from 351- Hz - 2000 Hz.

IMPORTANT: Welding the bracket to the mounting surface is NOT RECOMMENDED. Excessive frame vibration may necessitate the relocation of the mounting bracket to a more stable location. Also, do not weld the bracket in a location that inhibits the removal of the radar.

INSTALLATION INSTRUCTIONS



CAUTION

If at any time an arc welder is used on the vehicle, or anything connected to the vehicle, disconnect all power and ground leads that provide power for the system. Failure to do so can result in damaged electronic components, in which case the warranty will be VOID.

3. Refer to the following illustration and install the radar mounting hardware as shown.
4. Ensure the radar is above the pipe with its face toward the rear of the vehicle (if possible) and the enclosure seam placed down toward the mounting plate.
5. Tighten the three nuts holding the isolation mounts to the sensor.
6. Tighten the radar to the Mounting Plate using three nuts and lock washers.
7. Tighten the U-bolts until the radar will hold position but can still be adjusted as needed on the pipe.

Figure 5

Radar Mounting

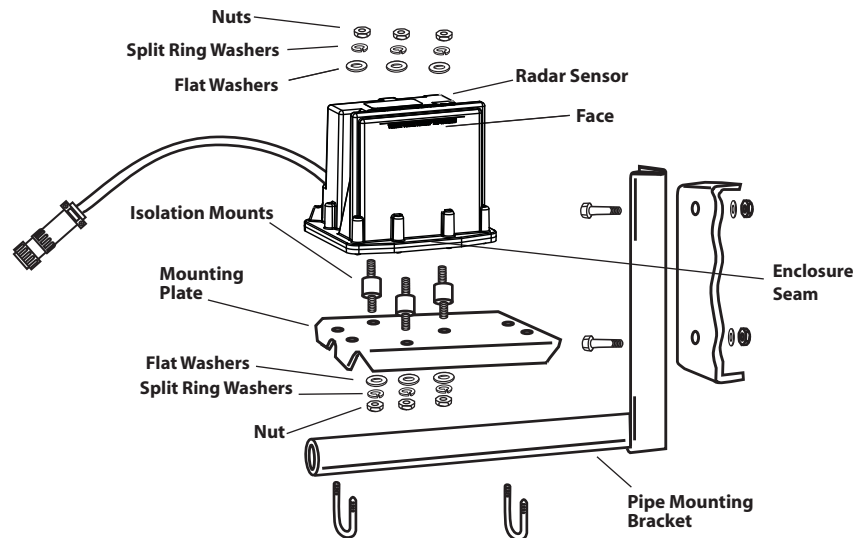

CAUTION

Do not exceed 30 - 35 in-lbs (3.0 - 3.5 Nm) of torque when tightening the nuts of the three Isolation mounts when securing the Radar III to the mounting bracket. Overtightening the nuts can fracture the Radar sensor housing. Ensure the rubber isolation mounts do not twist when tightening. Overtightening can cause the rubber to tear compromising radar mounting.

INSTALLATION INSTRUCTIONS



8. Refer to Figure 6 and hold the mounting bracket template for pipe installation behind the the radar sensor over the pipe as shown. (Template is located on page 13 of this instruction.)

Figure 6

Pipe Mounting Installation

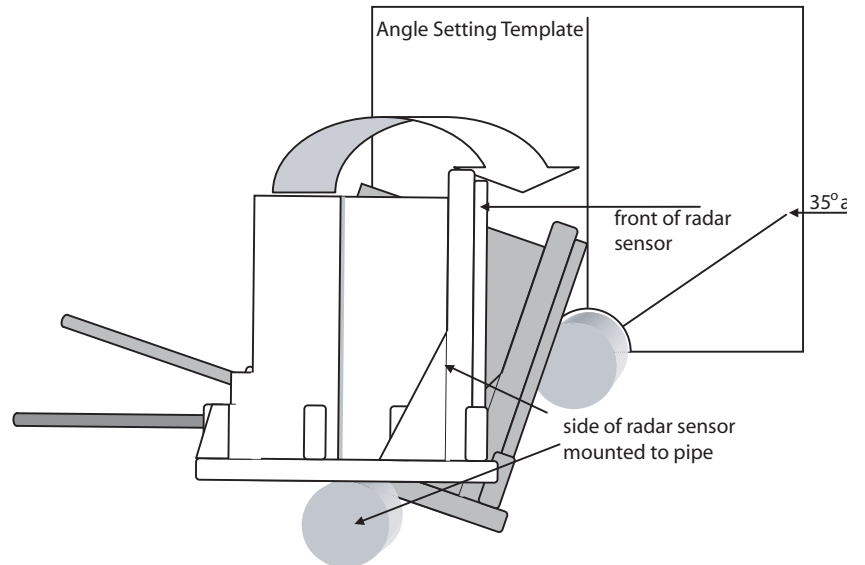

9. Rotate the radar on the mounting pipe until the front of the radar aligns with the 35° angle on the template.
10. Tighten the mounting hardware.

IMPORTANT: The vehicle must be on level ground when the angle is set.

IMPORTANT: The radar housing must not come in contact with the vehicle frame or the mounting bracket. Such contact can cause erratic readings by introducing electrical noise into the radar and could potentially cause electrical damage to the radar.

INSTALLATION INSTRUCTIONS



POWER CONNECTION

Refer to the following diagrams (Figure 7 and 8) illustrating the connection relationship for both 12V and 24V systems.

- The Radar is a 12V system that can be connected to an implement operating on 12V by routing the radar harness to the console and attaching the mating connectors.

Figure 7

12V Power Connection

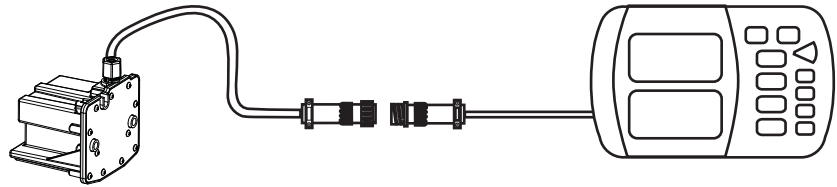

- A 24V adapter assembly is available for implements operating with 24V systems. The adapter assembly is attached between the console and radar and connected to the corresponding mating connectors.

Figure 8

24V Power Connection

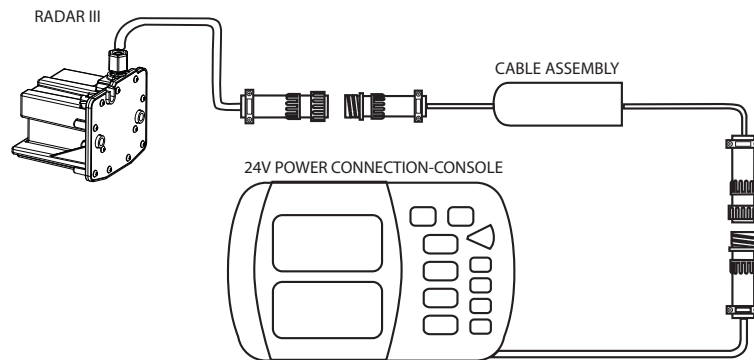

CAUTION

All 24V vehicles must use the adapter cable assembly provided with the kit. Failure to do so can cause electrical damage to the radar.

INSTALLATION INSTRUCTIONS



NOTE: Operational vibration limits (with isolation mounts) are 0.75 grms from 200 Hz - 350 Hz and 3 grms from 351 Hz - 2000 Hz.

IMPORTANT: Do not secure the cable until the radar has been checked for vibration. Excessive vibration can cause ground speed (MPH) readings to be above zero when the vehicle is stationary.

VIBRATION CHECK

To check for vibration, start the vehicle engine and slowly increase engine RPM (while watching the ground speed readout) to approximately 1800. If the ground speed readings are above zero, the radar must be mounted in an alternate, more stable location. After the radar readings are checked and found to be stable, secure the radar cable in a protected location.

CONSOLE CALIBRATION

After radar installation and the system is operational, the radar or console must be calibrated.

Refer to the Monitor Console Installation and Operation Manual and perform the ground speed (distance) calibration procedure as described.

INSTALLATION INSTRUCTIONS



PLATE MOUNTING BRACKET

(Fabricated By User)

For applications that cannot use the provided DICKEY-john mounting brackets, Figure 9 provides a dimensional drawing of a plate mounting bracket that can be fabricated by the installer. The mounting plate must be made of 5/16 inch or thicker steel plate.

IMPORTANT: Using a steel plate less than 5/16 inch can cause the radar velocity sensor to vibrate causing erroneous MPH (kph) readings.

NOTE: Operational vibration limits (with isolation mounts) are 0.75 grms from 200 Hz - 350 Hz and 3 grms from 351 Hz - 2000 Hz.

Figure 9

Plate Mounting Bracket Dimensions for Fabricated Mounting Bracket

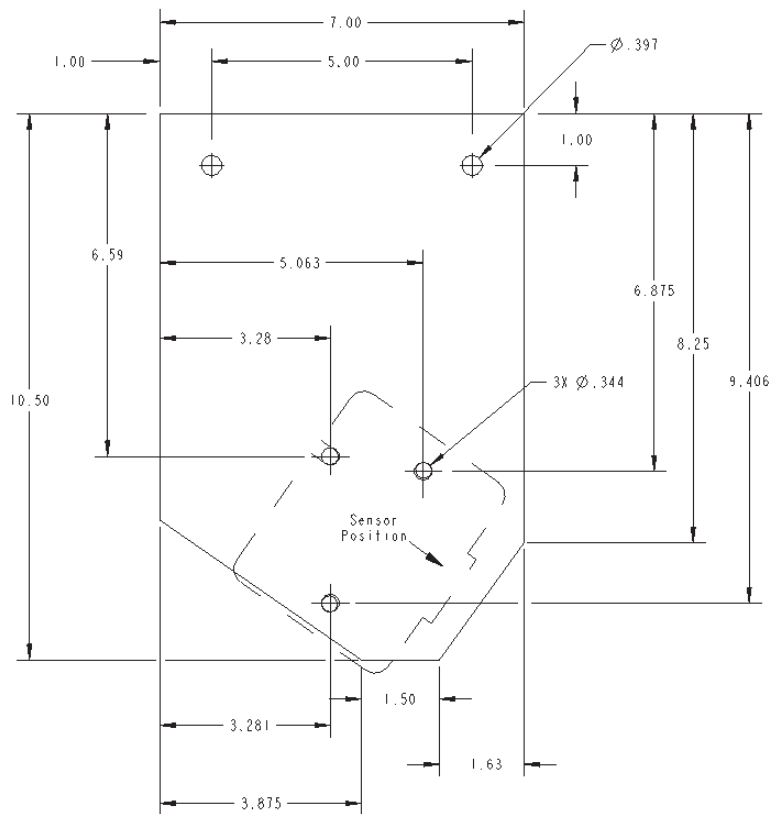

NOTE: The mounting plate must not extend past the radar housing. Metal beside the face area can cause improper operation of the radar.

Suggested mounting hardware for a 5/16 inch plate is as follows:

1. 3/8 - 16 x 1 1/2" Bolts (2)
2. 3/8 Split Ring Lockwashers (2)
3. 3/8 Nuts (2)
4. Vibration Isolation Mounting Hardware Kit
 - 6 mm Nuts (6)
 - 6 mm Isolation Mounts (3)
 - 6 mm Flat Lockwashers (6)
 - 6 mm Split Ring Lock Washers (6)

INSTALLATION INSTRUCTIONS



FABRICATED MOUNTING PLATE INSTALLATION

NOTE: 2006 models of the Vibration Isolation Mount hardware kit use 1/4" hardware (kit 467830781)

Figure 10 illustrates installing the Radar on a flat plate mounting bracket with the enclosure seam on the side. Ensure spacers are installed as shown.

Figure 10

Fabricated Mounting Plate Installation

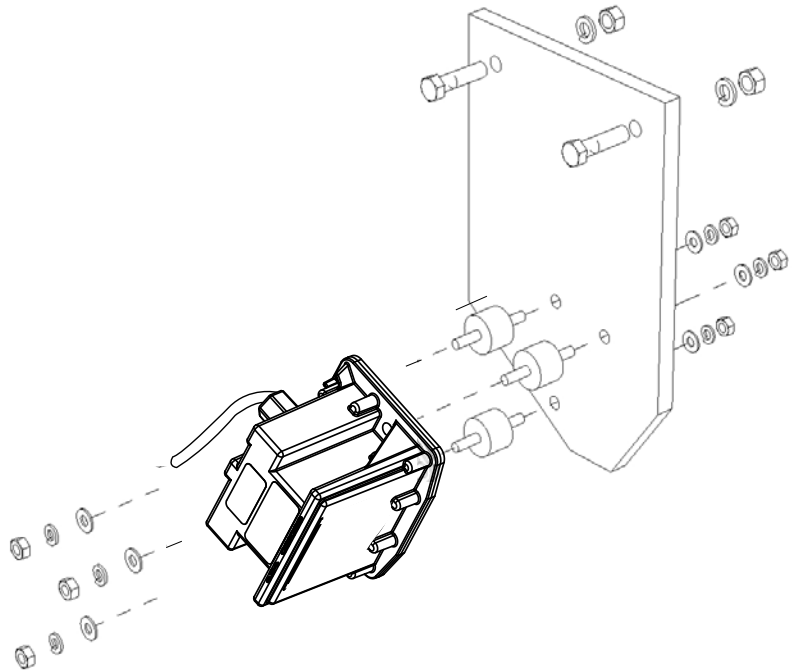

CAUTION

Do not exceed 30 - 35 in-lbs (3.0 - 3.5 Nm) of torque when tightening the nuts of the three isolation mounts when securing the Radar III to the mounting bracket. Over tightening the nuts can fracture the Radar sensor housing. Ensure rubber isolation mounts do not twist when tightening. Overtightening can cause the rubber to tear compromising radar mounting.

INSTALLATION INSTRUCTIONS



Mounting Plate Installation:

1. Drill out the "A" mounting hole.
2. Install a 3/8 inch bolt, lock washer, and nut.
3. Tighten the bolt enough so the mounting plate will hold position without slipping.
4. Tape the alignment template to the radar.
5. Using a small carpenter's level, rotate the mounting plate until the dotted line on the template is level.
6. Drill out the "B" mounting hole. If necessary, the "B" mounting hole can be oveled out to provide the rotation necessary to adjust the radar angle.

Figure 11

Mounting Plate

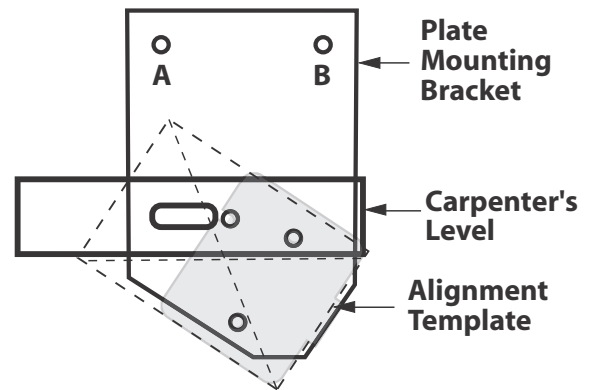

INSTALLATION INSTRUCTIONS



MOUNTING BRACKET TEMPLATE FOR PLATE

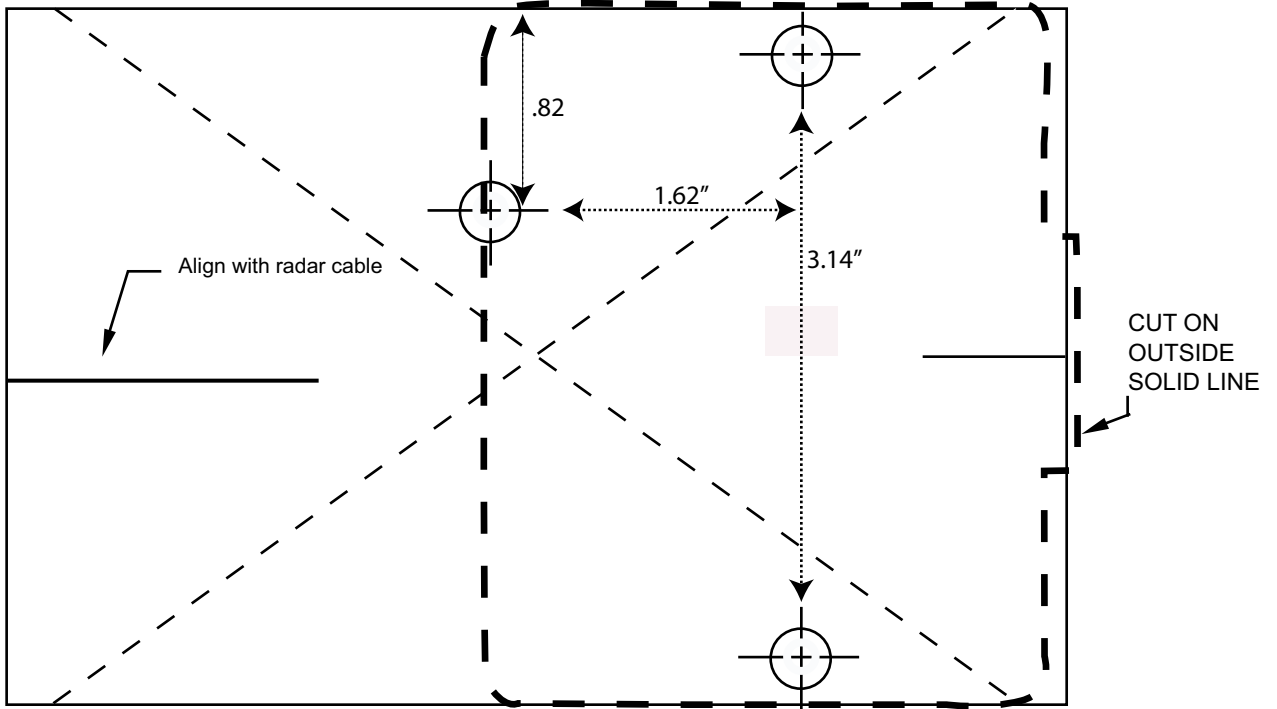

MOUNTING BRACKET TEMPLATE FOR PIPE

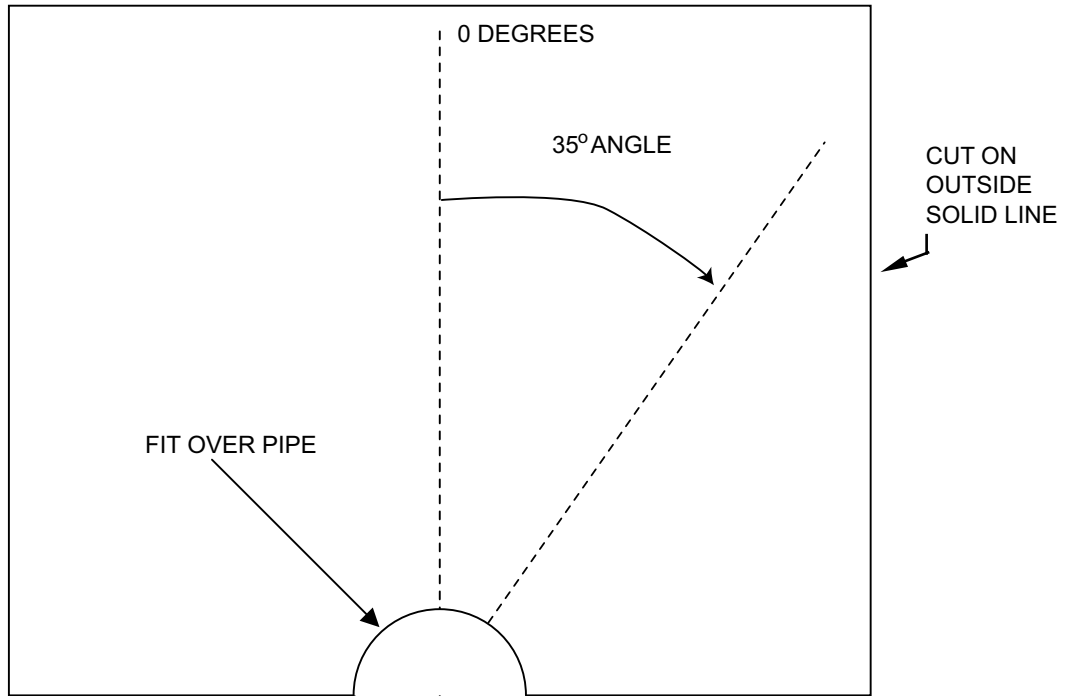

SAFETY INFORMATION

INSTALLATION INSTRUCTIONS



POWER - 12V VERSION

Voltage: 13.0V nominal (9.0 - 16.0V)
Current: Less than.60A

POWER - 24V VERSION (REQUIRES 24V DJ RVS III ADAPTER CABLE ASSEMBLY P/N 467830812)

Voltage: 26.0V nominal (18.0 - 32.0V)
Current: Less than.63A

ELECTRICAL PROTECTION

On both versions, power is to be supplied to the radar by a 5A automotive type fuse (or less) to protect the circuit. Reverse Polarity protection is built into the Radar using series diode (radar has open circuit to protect against reverse polarity on power lines).

SAFETY

The DICKEY-john RVS III Radar is an intentional radiator of RF energy. Although its radiated energy level is far below the limits set by En 61010-1: 1993 \ A2: 1995 - Chapter 12.4, it is advisable not to look directly into the face of the unit.

The radar must radiate toward the ground and at least 20 cm (8 inches) away from a human during use to comply with the RF human exposure limits as called out in FCC 47 CRFR sec. 2.1091. **DO NOT MOUNT THE RADAR IN A MANNER INCONSISTENT WITH ITS DEFINED USE.**

MAINTENANCE

The DICKEY-john RVSIII Radar requires no periodic maintenance. It has been designed to withstand typical environmental conditions found on the underside of an agricultural tractor or vehicle. If the radar is spray washed, do not exceed 65 Bars of pressure and maintain a distance of at least 1 meter.

MANUFACTURER

DICKEY-john Corporation
5200 Dickey-john Road
Auburn, Illinois 62615
Tel: (217) 438-3371
Fax: (217) 438-6012

EUROPEAN SUBSIDIARY

DICKEY-john Europe S.A.
165, Boulevard de Valmy
92706 Colombes, France
Tel: 33 1 41 19 21 80
Fax: 33 1 47 86 00 07