



FCC CFR47 PART 95H REQUIREMENT

CERTIFICATION TEST REPORT

FOR

MEDICAL TELEMETRY TRANSMITTER

MODEL: ZM-530PA

FCC ID: B6BZM-530PA

REPORT NUMBER: 31JE0089-HO-A

ISSUE DATE: JUNE 15, 2011

**Prepared for
NIHON KOHDEN CORPORATION
1-31-4, NISHIOCHIAI SHINJUKU-KU
TOKYO 161-8560, JAPAN**

**Prepared by
UL Japan, Inc.
Head Office EMC Lab.
4383-326 Asama-cho, Ise-shi, Mie-ken 516-0021 JAPAN
TEL: +81 596 24 8116
FAX: +81 596 24 8124**



NVLAP LAB CODE: 200572-0

This laboratory is accredited by the NVLAP LAB CODE 200572-0, U.S.A. The tests reported herein have been performed in accordance with its terms of accreditation. *As for the range of Accreditation in NVLAP, you may refer to the WEB address, <http://www.ul.com/japan/jpn/pages/services/emc/about/mark1/index.jsp#nvlap>

Revision History

<u>Rev.</u>	<u>Issue Date</u>	<u>Revisions</u>	<u>Revised By</u>
--	06/15/11	Initial Issue	T. Hatakeda

TABLE OF CONTENTS

1. ATTESTATION OF TEST RESULTS	4
2. TEST METHODOLOGY	5
3. FACILITIES AND ACCREDITATION	5
4. CALIBRATION AND UNCERTAINTY	5
4.1. <i>MEASURING INSTRUMENT CALIBRATION.....</i>	5
4.2. <i>SAMPLE CALCULATION.....</i>	5
4.3. <i>MEASUREMENT UNCERTAINTY</i>	6
5. EQUIPMENT UNDER TEST.....	7
5.1. <i>DESCRIPTION OF EUT.....</i>	7
5.2. <i>DESCRIPTION OF AVAILABLE ANTENNAS.....</i>	7
5.3. <i>SOFTWARE AND FIRMWARE.....</i>	7
5.4. <i>WORST-CASE CONFIGURATION AND MODE</i>	7
5.5. <i>DESCRIPTION OF TEST SETUP</i>	8
6. TEST AND MEASUREMENT EQUIPMENT	11
7. ANTENNA PORT TEST RESULTS.....	12
7.1. <i>26 dB AND 99% BW</i>	12
7.2. <i>PEAK OUTPUT POWER.....</i>	15
7.3. <i>AVERAGE POWER</i>	16
7.4. <i>SPURIOUS EMISSIONS AT ANTENNA TERMINAL.....</i>	17
7.5. <i>FREQUENCY STABILITY MEASUREMENT.....</i>	19
8. RADIATED EMISSION TEST RESULTS.....	23
8.1. <i>FUNDAMENTAL OUTPUT POWER.....</i>	24
8.2. <i>RADIATED EMISSIONS BELOW 960 MHz.....</i>	25
8.3. <i>RADIATED EMISSIONS ABOVE 960 MHz.....</i>	30
9. SETUP PHOTOS.....	32

1. ATTESTATION OF TEST RESULTS

COMPANY NAME: NIHON KOHDEN CORPORATION
1-31-4, NISHIOCHIAI SHINJUKU-KU
TOKYO 161-8560, JAPAN

EUT DESCRIPTION: MEDICAL TELEMETRY TRANSMITTER

MODEL: ZM-530PA

SERIAL NUMBER: 93001

DATE TESTED: MAY 19 – JUNE 13, 2011

APPLICABLE STANDARDS	
STANDARD	TEST RESULTS
FCC PART 95 SUBPART H	Pass

UL Japan, Inc. tested the above equipment in accordance with the requirements set forth in the above standards. All indications of Pass/Fail in this report are opinions expressed by UL Japan, Inc. based on interpretations and/or observations of test results. Measurement Uncertainties were not taken into account and are published for informational purposes only. The test results show that the equipment tested is capable of demonstrating compliance with the requirements as documented in this report.

Note: The results documented in this report apply only to the tested sample, under the conditions and modes of operation as described herein. This document may not be altered or revised in any way unless done so by UL Japan, Inc. and all revisions are duly noted in the revisions section. Any alteration of this document not carried out by UL Japan, Inc. will constitute fraud and shall nullify the document. This report must not be used by the client to claim product certification, approval, or endorsement by NVLAP, NIST, any agency of the Federal Government, or any agency of any government.

Approved & Released For UL Japan, Inc. By: Tested By:



TAKAHIRO HATAKEDA
Leader of WiSE Japan
UL Verification Services
UL Japan, Inc.



KATSUNORI OKAI
Engineer of WiSE Japan
UL Verification Services
UL Japan, Inc.

2. TEST METHODOLOGY

The tests documented in this report were performed in accordance with ANSI/TIA-603-C-2004, FCC CFR 47 Part 2 and FCC CFR 47 Part 95.

3. FACILITIES AND ACCREDITATION

The test sites and measurement facilities used to collect data are located at 4383-326 Asama-cho, Ise-shi, Mie-ken 516-0021 JAPAN.

UL Japan, Inc. is accredited by NVLAP, Laboratory Code 200572-0
The full scope of accreditation can be viewed at
<http://www.ul.com/japan/jpn/pages/services/emc/about/mark1/index.jsp#nvlap>

4. CALIBRATION AND UNCERTAINTY

4.1. MEASURING INSTRUMENT CALIBRATION

The measuring equipment utilized to perform the tests documented in this report has been calibrated in accordance with the manufacturer's recommendations, and is traceable to recognized national standards.

4.2. SAMPLE CALCULATION

Where relevant, the following sample calculation is provided:

$$\begin{aligned} \text{Field Strength (dBuV/m)} &= \text{Measured Voltage (dBuV)} + \text{Antenna Factor (dB/m)} + \text{Cable} \\ &\text{Loss (dB)} - \text{Preamp Gain (dB)} \\ 36.5 \text{ dBuV} + 18.7 \text{ dB/m} + 0.6 \text{ dB} - 26.9 \text{ dB} &= 28.9 \text{ dBuV/m} \end{aligned}$$

4.3. MEASUREMENT UNCERTAINTY

Where relevant, the following measurement uncertainty levels have been estimated for tests performed on the apparatus:

The following uncertainties have been calculated to provide a confidence level of 95% using a coverage factor k=2.

Test room (semi-anechoic chamber)	Radiated emission						
	(3m*)(±dB)				(1m*)(±dB)		(0.5m*)(±dB)
	9kHz -30MHz	30MHz - 300MHz	300MHz -1GHz	1GHz -10GHz	10GHz -18GHz	18GHz -26.5GHz	26.5GHz -40GHz
No.1	3.5dB	5.1dB	5.2dB	4.8dB	5.1dB	4.4dB	4.3dB
No.2	4.0dB	5.1dB	5.2dB	4.8dB	5.0dB	4.3dB	4.2dB
No.3	4.2dB	4.7dB	5.2dB	4.8dB	5.0dB	4.5dB	4.2dB
No.4	4.0dB	5.0dB	5.1dB	4.8dB	5.0dB	5.1dB	4.2dB

*3m/1m/0.5m = Measurement distance

Power meter (±dB)	
Below 1GHz	Above 1GHz
1.0dB	1.0dB

Antenna terminal conducted emission and Power density (±dB)			Antenna terminal conducted emission (±dB)		Channel power (±dB)
Below 1GHz	1GHz-3GHz	3GHz-18GHz	18GHz-26.5GHz	26.5GHz-40GHz	
1.0dB	1.1dB	2.7dB	3.2dB	3.3dB	1.5dB

5. EQUIPMENT UNDER TEST

5.1. DESCRIPTION OF EUT

a).	Type of EUT:	WMTS TRANSMITTER
b).	Brand Name:	NIHON KOHDEN
c).	Model No:	ZM-530PA
d).	FCC ID:	B6BZM-530PA
e).	Battery Type:	Two AA (LR6)
f).	Channel Number:	608.0250 MHz (channel number 9002) to 613.9750 MHz (channel number 9478)
g).	Frequency Range:	608.025-613.975 MHz
h).	RF Conducted Output Power:	1mW
i).	Channel Spacing:	50kHz or 37.5kHz (12.5kHz when interleave)
j).	Modulation	Frequency Shift Keying
k).	Type of Modulation:	F1D
l).	Occupied Bandwidth	<20 kHz
m).	Antenna Type:	Internal

5.2. DESCRIPTION OF AVAILABLE ANTENNAS

The radio utilizes a Helical Monopole antenna, with a maximum gain of 0 dBi.

5.3. SOFTWARE AND FIRMWARE

The test utility software used during testing was Channel Writer, ver. 02-04.
The test utility firmware used during testing was EUT, ver. 01-01.

5.4. WORST-CASE CONFIGURATION AND MODE

The worst-case channel is determined as the channel with the highest output power.

During emission tests the antenna orientations as X, Y, and Z were investigated to determine the worst-case. The outcome showed that X-orientation for Horizontal and Y-orientation for Vertical as the worst-case.

5.5. DESCRIPTION OF TEST SETUP

SUPPORT EQUIPMENT

PERIPHERAL SUPPORT EQUIPMENT LIST				
Description	Manufacturer	Model	Serial Number	FCC ID
Laptop	IBM	T42	L3NHT3F	DoC
AC/DC Adapter	IBM	92P1020	11S92P1020Z1Z9RM64CH86	DoC
Channel Writer	Nihon Kohden	QI-901PK	00349	N/A

I/O CABLES

I/O CABLE LIST						
Cable No.	Port	# of Identical Ports	Connector Type	Cable Type	Cable Length	Remarks
1	AC	1	US120V	Un-shielded	1.0m	N/A
2	DC	1	DC	Un-shielded	1.8m	Ferrite on laptop's end
3	USB	1	USB	Shielded	1.8m	No
4	ECG	1	ECG	Un-shielded	0.3m	No
5	ECG	1	ECG	Un-shielded	0.7 / 0.9 m	N/A
6	Sp02	1	Sp02	Un-shielded	1.6 m	Probe

TEST SETUP

The EUT is standalone unit and just use a host laptop computer to configure the mode during the tests. Test software exercised the radio card.

SETUP DIAGRAM FOR TESTS

RF Conducted test

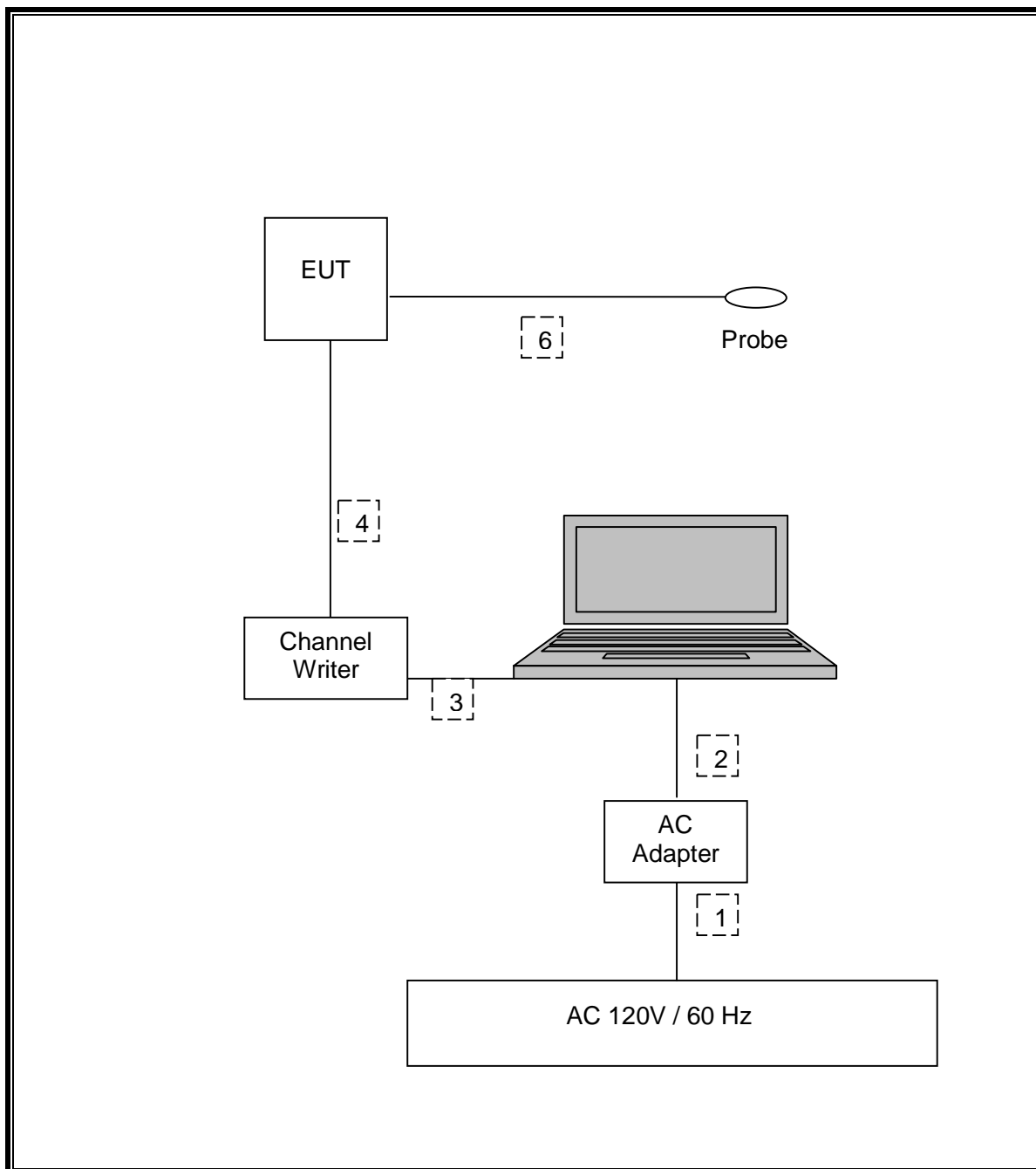

SETUP DIAGRAM FOR TESTS

RF Radiated test

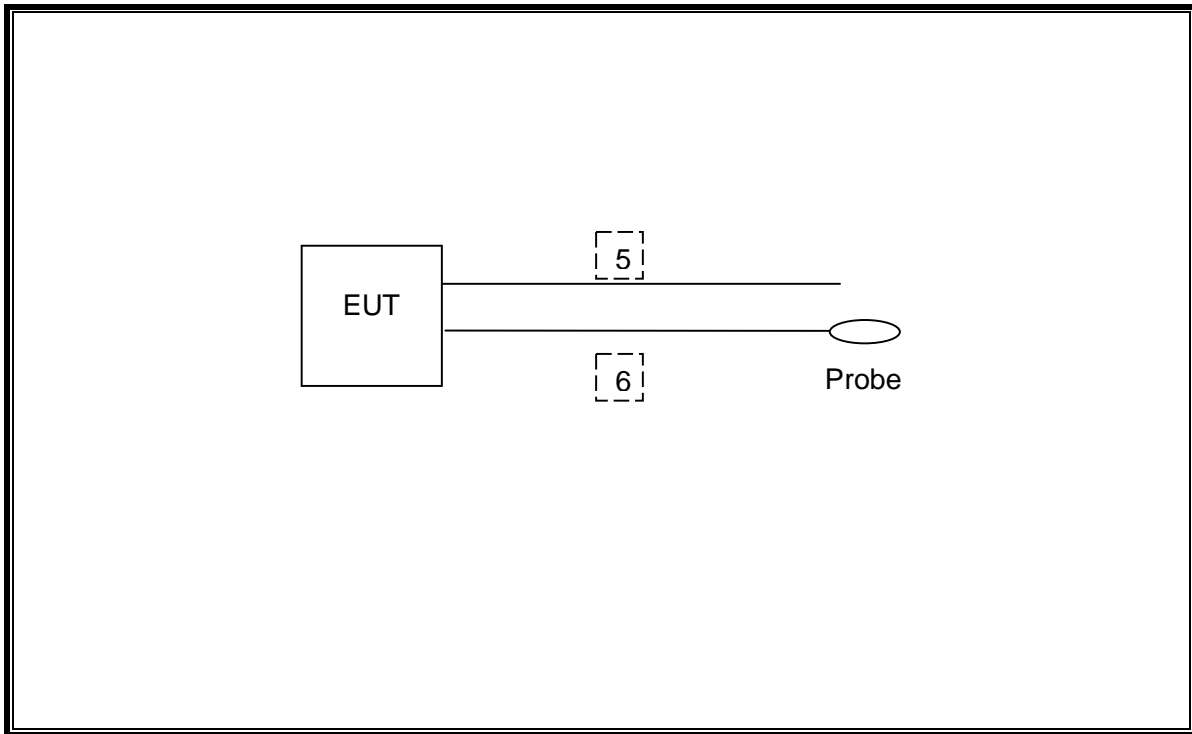

6. TEST AND MEASUREMENT EQUIPMENT

The following test and measurement equipment was utilized for the tests documented in this report:

Control No.	Instrument	Manufacturer	Model No	Serial No	Calibration Date * Interval(month)
COTS-MEMI	EMI measurement program	TSJ	TEPTO-DV	-	-
MAEC-03	Semi Anechoic Chamber(NSA)	TDK	Semi Anechoic Chamber 3m	DA-10005	2011/02/22 * 12
MOS-13	Thermo-Hygrometer	Custom	CTH-180	-	2011/02/23 * 12
MJM-06	Measure	PROMART	SEN1955	-	-
MSA-03	Spectrum Analyzer	Agilent	E4448A	MY44020357	2010/11/30 * 12
MTR-08	Test Receiver	Rohde & Schwarz	ESCI	100767	2010/08/23 * 12
MBA-03	Biconical Antenna	Schwarzbeck	BBA9106	1915	2010/10/11 * 12
MLA-03	Logperiodic Antenna	Schwarzbeck	USLP9143	174	2010/10/11 * 12
MCC-51	Coaxial cable	UL Japan	-	-	2010/07/06 * 12
MAT-09	Attenuator(6dB)	Weinschel Corp	2	BK7973	2010/11/05 * 12
MPA-13	Pre Amplifier	SONOMA INSTRUMENT	310	260834	2011/03/04 * 12
MHA-20	Horn Antenna 1-18GHz	Schwarzbeck	BBHA9120D	258	2011/05/23 * 12
MCC-18	Microwave Cable 1G-26.5GHz	Suhner	SUCOFLEX 104	148048-143(1m) / 292410(5m)	2010/09/30 * 12
MPA-11	MicroWave System Amplifier	Agilent	83017A	MY39500779	2011/03/10 * 12
MHF-04	High Pass Filter 1.22-4.60GHz	Mini-Circuit	VHF-1200	10435	2010/08/17 * 12
MCC-64	Coaxial Cable	UL Japan	-	-	2011/03/10 * 12
MAT-10	Attenuator(10dB)	Weinschel Corp	2	BL1173	2010/11/05 * 12
MSA-04	Spectrum Analyzer	Agilent	E4448A	US44300523	2011/04/08 * 12
MAT-23	Attenuator(10dB) 1-18GHz	Orient Microwave	BX10-0476-00	-	2011/03/14 * 12
MOS-04	Digital Humidity Indicator	N.T	NT-1800	MOS04	2011/02/23 * 12
MBM-11	Barometer	Sunoh	SBR121	839	2010/12/13 * 36
MPM-12	Power Meter	Anritsu	ML2495A	0825002	2010/08/20 * 12
MPSE-17	Power sensor	Anritsu	MA2411B	0738285	2010/08/20 * 12

The expiration date of the calibration is the end of the expired month.

All equipment is calibrated with traceable calibrations. Each calibration is traceable to the national or international standards.

As for some calibrations performed after the tested dates, those test equipment have been controlled by means of an unbroken chains of calibrations.

7. ANTENNA PORT TEST RESULTS

7.1. 26 dB AND 99% BW

LIMITS

§2.1049, for reporting purposes only, also the 26dB bandwidth shall be less than 20 KHz (F1D).

TEST PROCEDURE

ANSI C63.4

The transmitter output is connected to the spectrum analyzer.

26dB Bandwidth: The RBW is set to 1% to 3% of the 26dB bandwidth. The VBW is set to 3 times the RBW. The sweep time is coupled. The spectrum analyzer internal 26dB bandwidth function is utilized.

99% Bandwidth: The RBW is set to 1% to 3% of the 99 % bandwidth. The VBW is set to 3 times the RBW. The sweep time is coupled. The spectrum analyzer internal 99% bandwidth function is utilized.

RESULTS

26dB Bandwidth

Channel	Frequency (MHz)	26dB Bandwidth (kHz)
9002	608.025	17.776
9478	613.975	17.565

99% Bandwidth

Channel	Frequency (MHz)	99% Bandwidth (kHz)
9002	608.025	13.959
9478	613.975	14.126

26dB and 99% BANDWIDTH

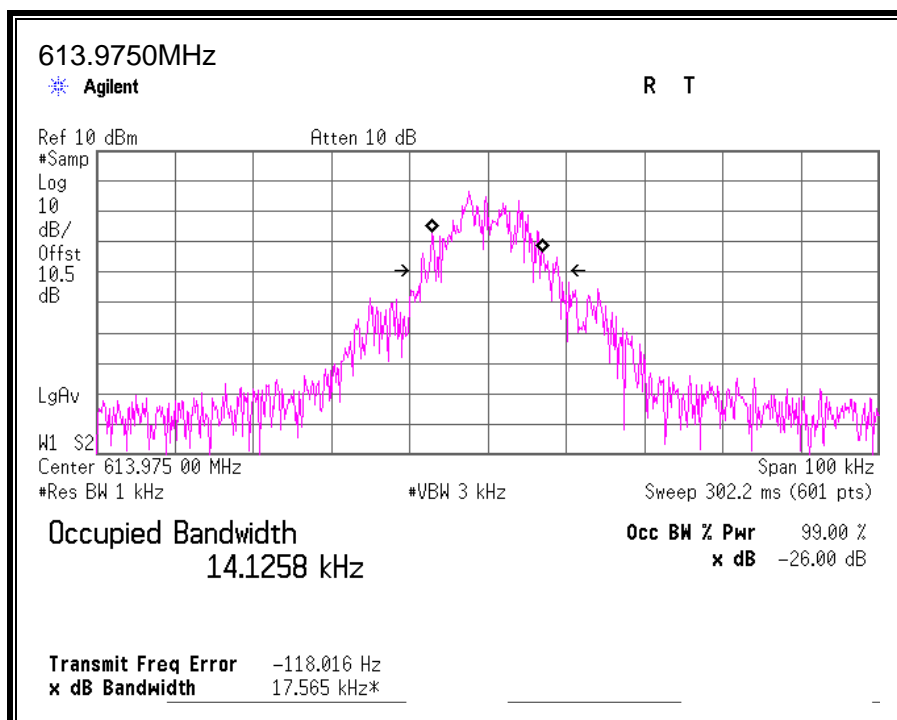
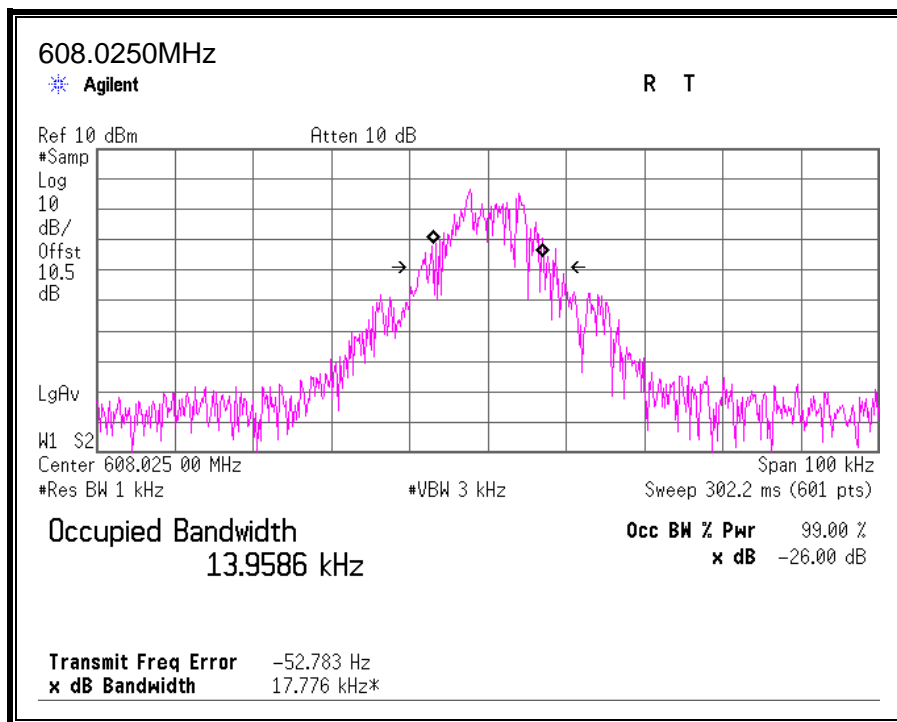

7.2. PEAK OUTPUT POWER

LIMITS

§2.1046, for reporting purposes only.

TEST PROCEDURE

The transmitter output is connected to a power meter.

RESULTS

The cable assembly insertion loss of 9.88 dB (including 9.88dB pad) was entered as an offset in the power meter to allow for direct reading of power.

Channel	Frequency (MHz)	Output Power (dBm)
9002	608.025	0.28
9478	613.975	0.25

7.3. AVERAGE POWER

LIMITS

None; for reporting purposes only.

TEST PROCEDURE

The transmitter output is connected to a power meter.

RESULTS

The cable assembly insertion loss of 10.5 dB (including 9.88dB pad & 0.62dB cable loss) was entered as an offset in the power meter to allow for direct reading of power.

Channel	Frequency (MHz)	Output Power (dBm)
9002	608.025	-0.24
9478	613.975	-0.11

7.4. SPURIOUS EMISSIONS AT ANTENNA TERMINAL

LIMIT

§2.1051 All the conducted emission spurious level shall be at least -20dBc below the band that contains the highest level of desired power.

TEST PROCEDURE

The transmitter output is connected to a spectrum analyzer. The RBW=1MHz , VBW=3MHz.

The spectrum from 30 MHz to 10th harmonic is investigated with the transmitter set to the lowest and highest channels.

TEST RESULTS

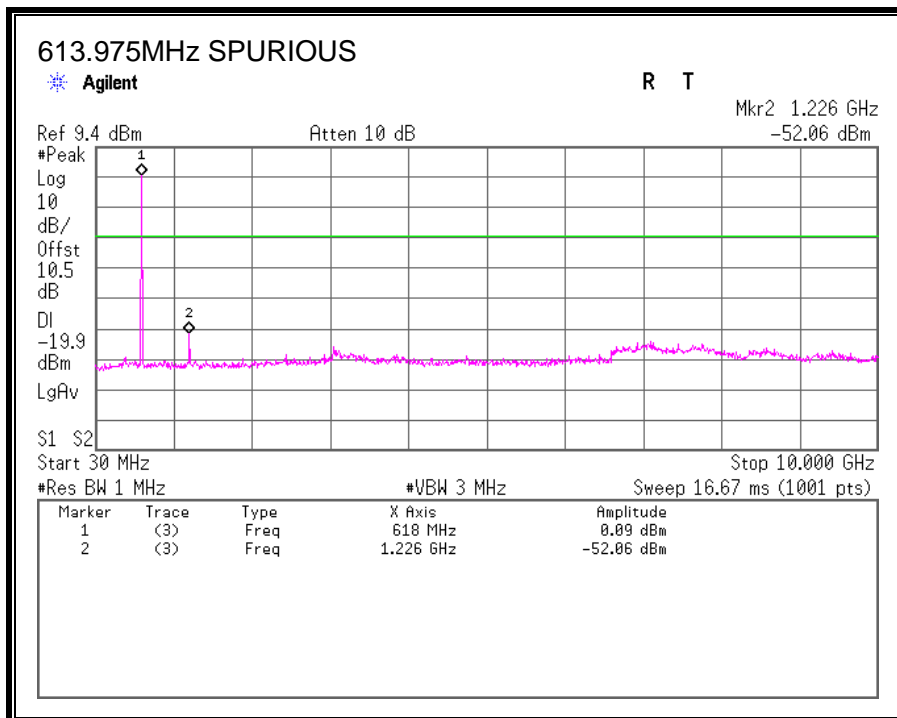
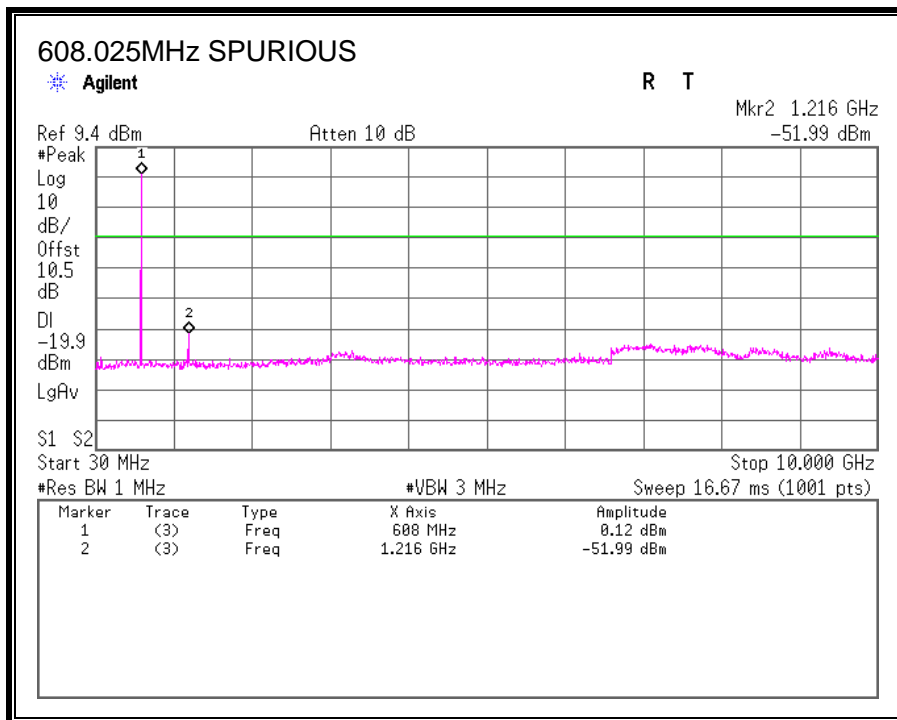

7.5. FREQUENCY STABILITY MEASUREMENT

LIMIT

§95.115 (e) Frequency stability.

Manufacturers of wireless medical telemetry devices are responsible for ensuring frequency stability such that an emission is maintained within the band of operation under all of the manufacturer's specified conditions.

TEST PROCEDURE

Frequency stability versus environmental temperature

- 1) Set the temperature of chamber to 25°C @ low/high channel. Allow sufficient time (approximately 30 min) for the temperature of the chamber to stabilize. While maintaining a constant temperature inside the chamber, turn the EUT on and measure the EUT operating frequency.
- 2) Set SA Resolution Bandwidth to 300 Hz and Video Resolution Bandwidth to 300 Hz and Frequency Span to 20 KHz. Record this frequency as reference frequency.
- 3) Repeat step 2 with a 10°C decreased per stage until the lowest temperature -30°C is measured, record all measured frequencies on each temperature step.
- 3) Repeat step 2 with a 10°C increased per stage until the highest temperature +50°C is measured; record all measured frequencies on each temperature step.

Frequency stability versus input voltage

- 1). Setup the configuration as shown below for frequencies measured at temperature if it is 25°C.
- 2). Set SA center frequency to the EUT radiated frequency. Set SA Resolution Bandwidth to 300 Hz and Video Resolution Bandwidth to 300 Hz and Frequency Span to 20 KHz. Record this frequency as reference frequency.
- 3). For battery operated only device, supply the EUT primary voltage at the operating end point which is specified by manufacturer and record the frequency.

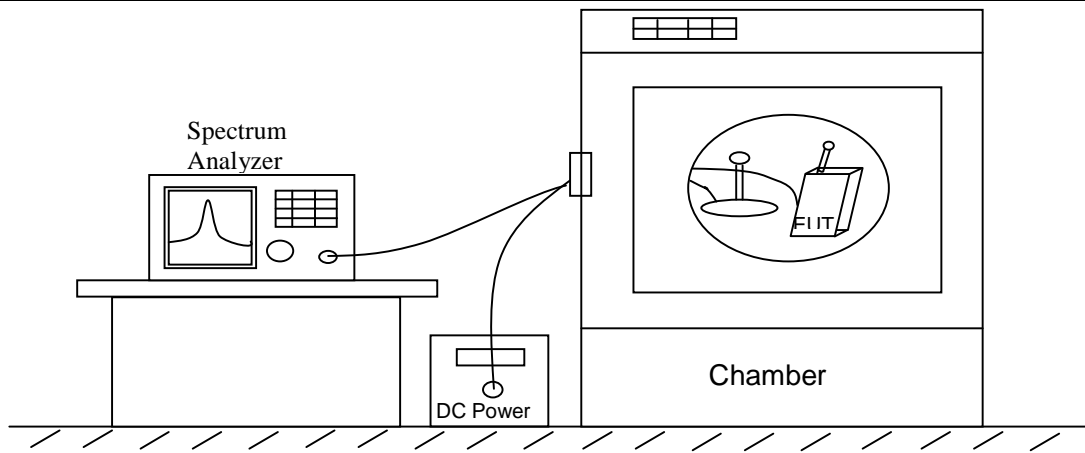

Frequency stability measurement configuration

TEST RESULTS

LOW CHANNEL

20°C Reference Frequency:			608.025000	MHz	
Limit: +/-	2.5	ppm =	0.001520	MHz	
Power Supply	Environment	Frequency	Delta (MHz)	Limit +/- (MHz)	
VDC	Temperature (°)	(MHz)			
3.00	Normal (100%)	50	608.023647	-0.001353	0.001520
		40	608.024042	-0.000958	0.001520
		30	608.024529	-0.000471	0.001520
		20	608.025753	0.000753	0.001520
		10	608.026231	0.001231	0.001520
		0	608.026211	0.001211	0.001520
		-10	608.025564	0.000564	0.001520
		-20	608.023803	-0.001197	0.001520
		-30	608.023904	-0.001096	0.001520
3.00	Normal	608.025753	0.000753	0.001520	
1.10	Low	608.025424	0.000424	0.001520	
1.00	End Point				

HIGH CHANNEL

20°C Reference Frequency:		613.975000		MHz	
Limit: +/- 2.5 ppm =		0.001535		MHz	
Power Supply	Environment	Frequency	Delta (MHz)	Limit +/- (MHz)	
VDC	Temperature (°)	(MHz)			
3.00	Normal (100%)	50	613.973645	-0.001355	0.001535
		40	613.974015	-0.000985	0.001535
		30	613.974661	-0.000339	0.001535
		20	613.975769	0.000769	0.001535
		10	613.976241	0.001241	0.001535
		0	613.976213	0.001213	0.001535
		-10	613.975593	0.000593	0.001535
		-20	613.974171	-0.000829	0.001535
		-30	613.973875	-0.001125	0.001535
3.00	Normal	613.975769	0.000769	0.001535	
1.10	Low	613.975444	0.000444	0.001535	
1.00	End Point				

8. RADIATED EMISSION TEST RESULTS

LIMITS

§95.115

(a) Field strength limits

(1) In the 608–614 MHz band, the maximum allowable field strength is 200 mV/m, as measured at a distance of 3 meters, using measuring instrumentation with a CISPR quasi-peak detector.

(b) Undesired emissions.

(1) Out-of-band emissions below 960 MHz are limited to 200 microvolts/meter, as measured at a distance of 3 meters, using measuring instrumentation with a CISPR quasi-peak detector.

(2) Out-of-band emissions above 960 MHz are limited to 500 microvolts/meter as measured at a distance of 3 meters, using measuring equipment with an averaging detector and a 1 MHz measurement bandwidth.

TEST PROCEDURE

ANSI/TIA-603-C-2004

RESULTS

8.1. FUNDAMENTAL OUTPUT POWER

Report No. : 31JE0089-HO
 Test Place : Head Office EMC Lab.
 Semi Anechoic Chamber: : No. 3
 Date : 2011/05/19
 Temperature/Humidity : 21 deg.C / 46% RH
 Engineer: : Katsunori Okai
 Mode: : Tx

Polarity	Frequency [MHz]	Detector	Reading [dBuV]	Ant.Fac. [dB/m]	Loss [dB]	Gain [dB]	Result [dBuV/m]	Limit [dBuV/m]	Margin [dB]	Remark
Hori	608.025	QP	92.3	20.2	11.6	32.2	91.9	106.0	14.1	X-axis
Vert	608.025	QP	87.9	20.2	11.6	32.2	87.5	106.0	18.5	Y-axis
Hori	613.975	QP	92.1	20.3	11.6	32.2	91.8	106.0	14.2	X-axis
Vert	613.975	QP	87.3	20.3	11.6	32.2	87.0	106.0	19.0	Y-axis

Result = Reading + Ant Factor + Loss (Cable+Attenuator+Filter) - Gain(Amplifier)

8.2. RADIATED EMISSIONS BELOW 960 MHz

Note 1: The measurements in this section show that Peak values are less than the Quasi-Peak limit.

Note 2: Plots in the range of 960 to 1000 MHz in this section are shown for reporting purposes only.

SPURIOUS EMISSIONS 30 TO 960 MHz (HORIZONTAL)

608.025MHz

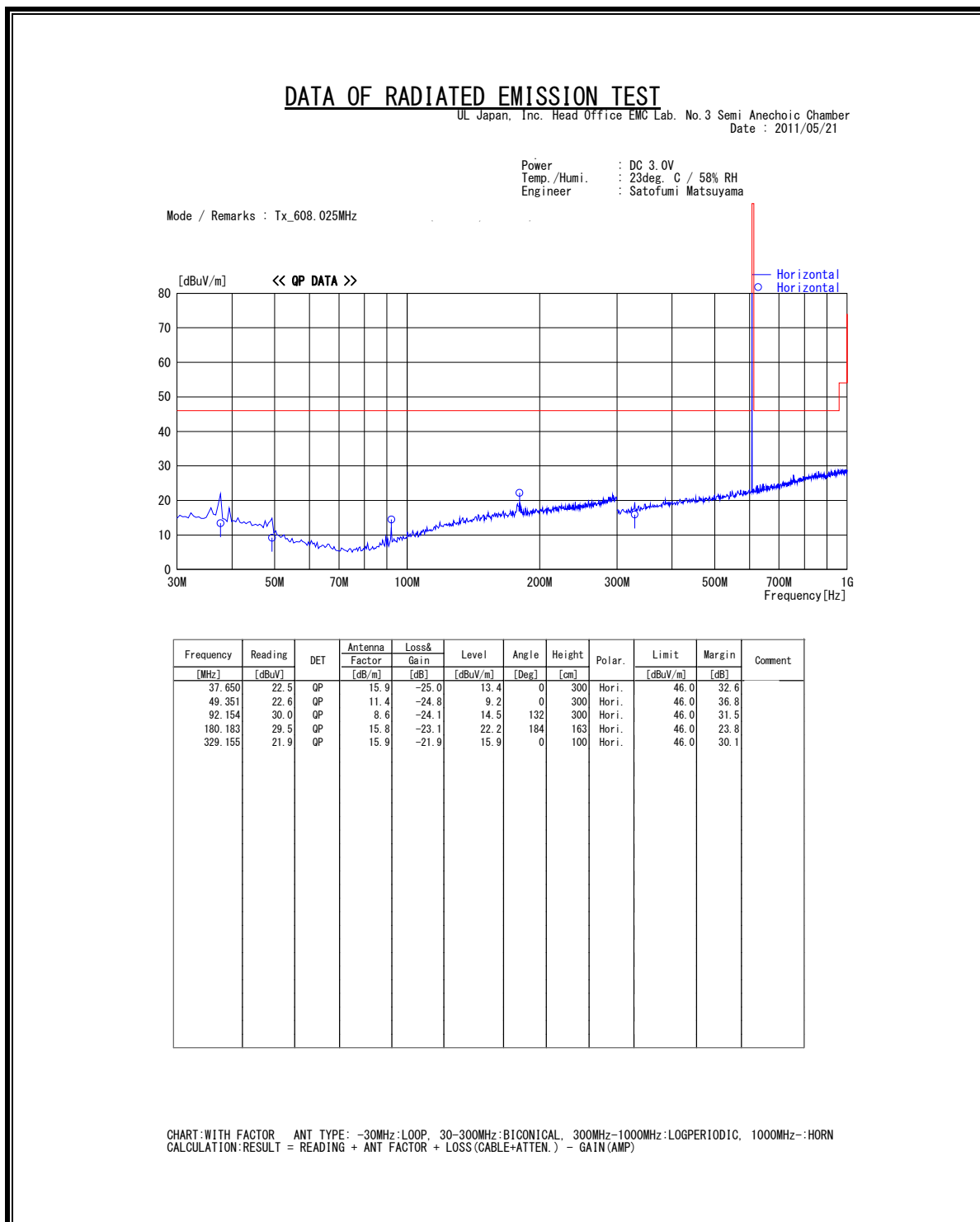

SPURIOUS EMISSIONS 30 TO 960 MHz (VERTICAL)

608.025MHz

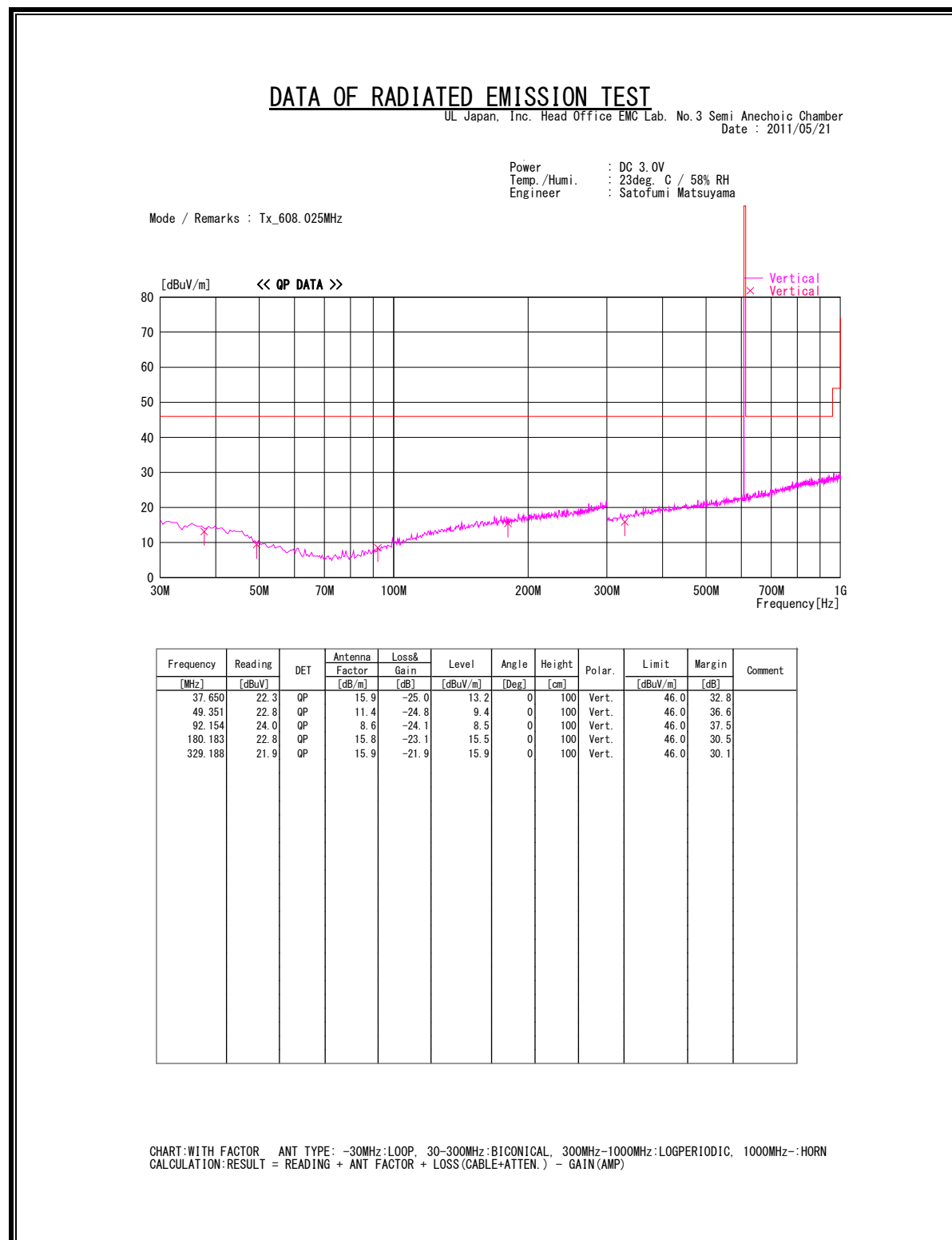

SPURIOUS EMISSIONS 30 TO 960 MHz (HORIZONTAL)

613.975MHz

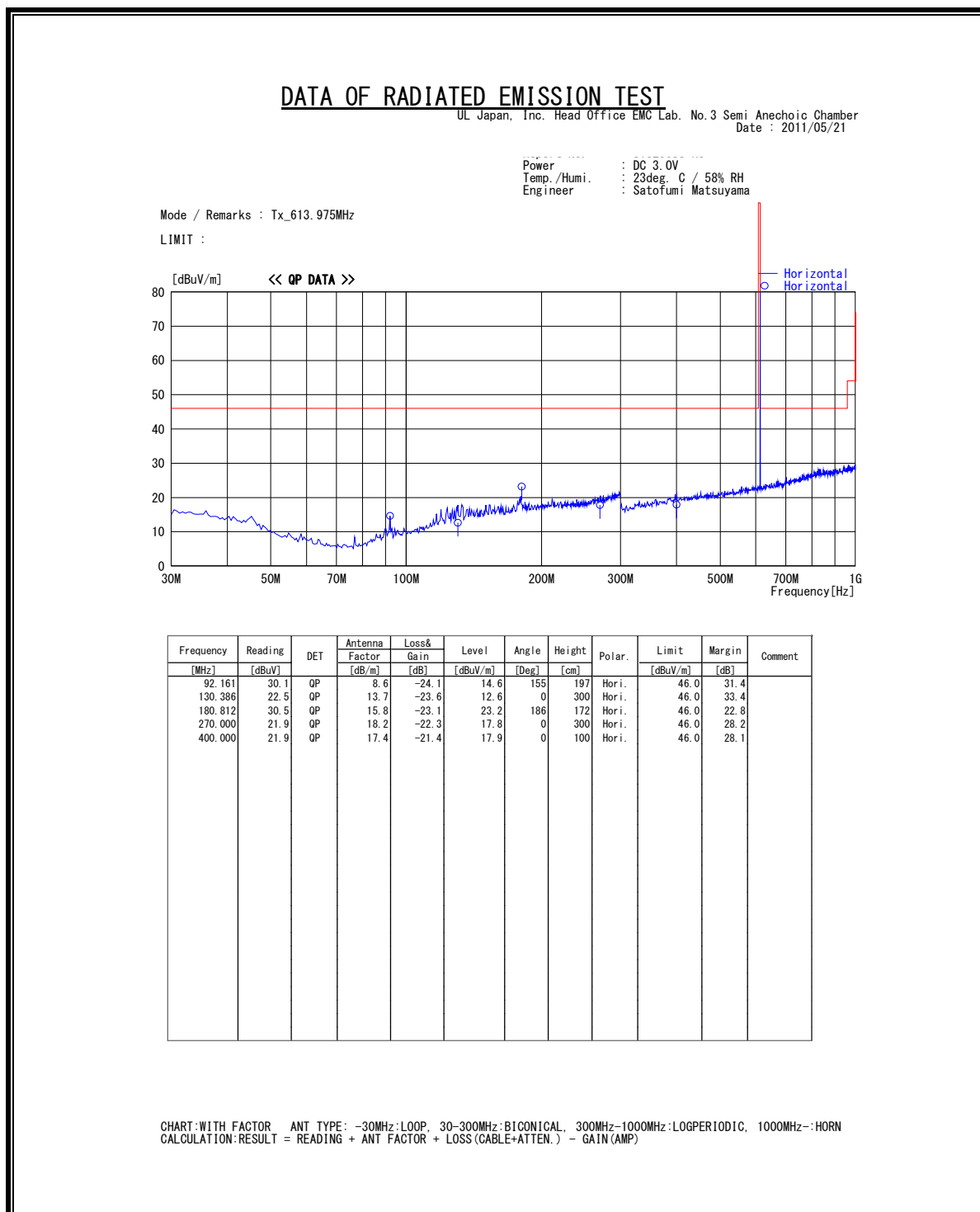

SPURIOUS EMISSIONS 30 TO 960 MHz (VERTICAL)

613.975MHz

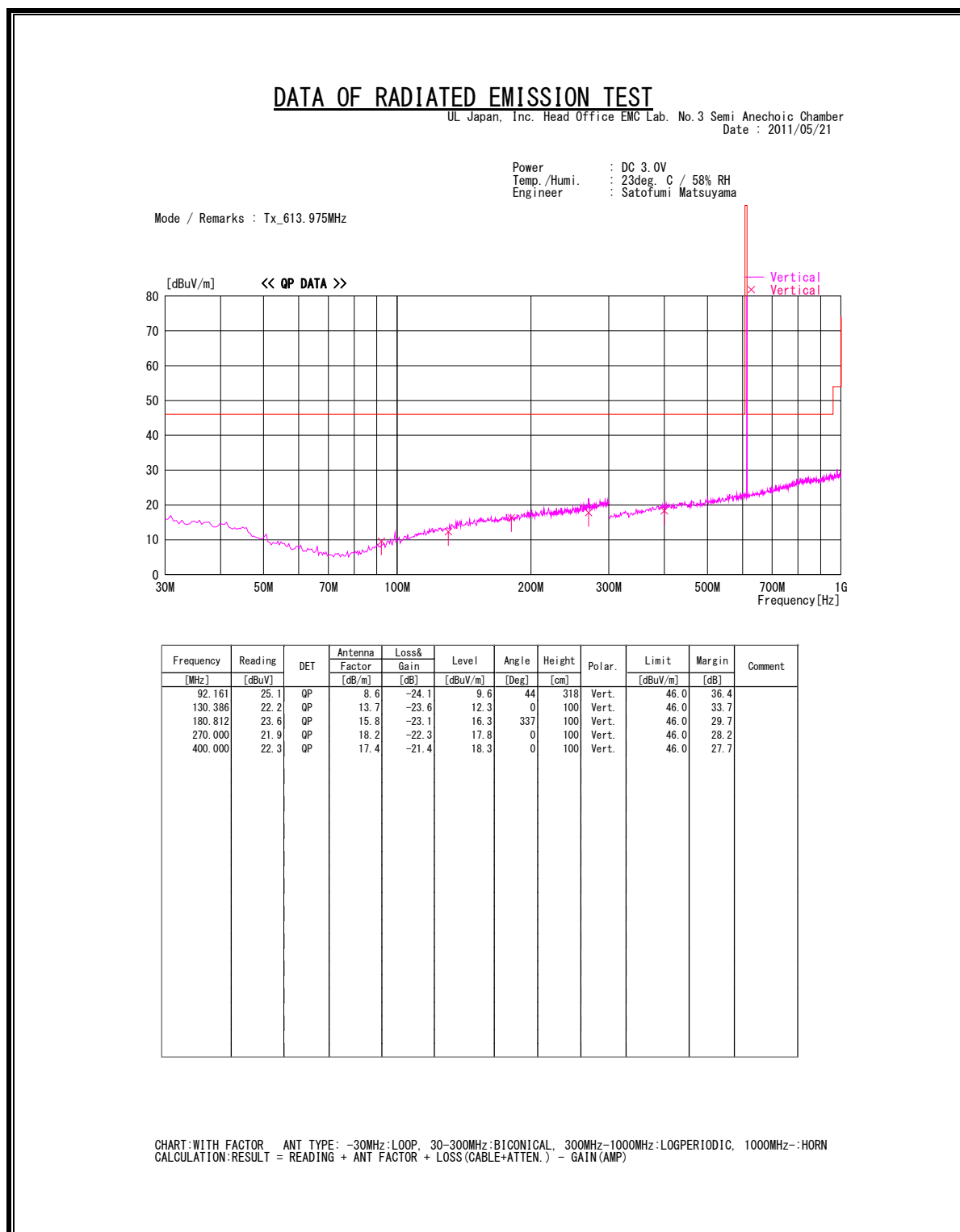

8.3. RADIATED EMISSIONS ABOVE 960 MHz

HARMONICS AND TX SPURIOUS EMISSIONS ABOVE 960 MHz 608.025MHz

Report No. : 31JE0089-HO
 Test Place : Head Office EMC Lab.
 Semi Anechoic Chamber: : No. 3
 Date : 2011/05/23
 Temperature/Humidity : 23 deg.C / 59% RH
 Engineer: : Keisuke Kawamura
 Mode: : Tx 608.025MHz

Polarity	Frequency [MHz]	Detector	Reading [dBuV]	Ant.Fac. [dB/m]	Loss [dB]	Gain [dB]	Result [dBuV/m]	Limit [dBuV/m]	Margin [dB]	Remark
Hori	1216.050	AV	35.3	25.8	3.9	34.7	30.3	54.0	23.7	
Hori	1824.075	AV	35.7	27.8	2.7	33.2	33.0	54.0	21.0	
Hori	2432.100	AV	53.2	27.7	2.8	32.6	51.1	54.0	2.9	
Hori	3040.125	AV	39.0	29.2	3.2	32.3	39.1	54.0	15.0	
Hori	3648.150	AV	40.5	30.0	3.9	32.0	42.4	54.0	11.6	
Hori	4256.175	AV	45.0	30.4	4.5	31.9	48.0	54.0	6.0	
Hori	4864.200	AV	30.6	31.8	5.5	31.9	36.0	54.0	18.0	
Hori	5472.225	AV	31.9	32.2	6.7	32.0	38.8	54.0	15.2	
Hori	6080.250	AV	30.7	33.4	7.8	32.1	39.8	54.0	14.2	
Vert	1216.050	AV	39.0	25.8	3.9	34.7	34.0	54.0	20.0	
Vert	1824.075	AV	37.3	27.8	2.7	33.2	34.6	54.0	19.4	
Vert	2432.100	AV	52.7	27.7	2.8	32.6	50.6	54.0	3.4	
Vert	3040.125	AV	40.7	29.2	3.2	32.3	40.8	54.0	13.2	
Vert	3648.150	AV	36.9	30.0	3.9	32.0	38.8	54.0	15.2	
Vert	4256.175	AV	40.7	30.4	4.5	31.9	43.7	54.0	10.3	
Vert	4864.200	AV	29.0	31.8	5.5	31.9	34.4	54.0	19.6	
Vert	5472.225	AV	30.0	32.2	6.7	32.0	36.9	54.0	17.1	
Vert	6080.250	AV	30.1	33.4	7.8	32.1	39.2	54.0	14.8	

Result = Reading + Ant Factor + Loss (Cable+Attenuator+Filter-Distance factor) - Gain(Amplifier)

HARMONICS AND TX SPURIOUS EMISSIONS ABOVE 960 MHz
613.975MHz

Report No. : 31JE0089-HO
Test Place : Head Office EMC Lab.
Semi Anechoic Chamber: : No. 3
Date : 2011/05/23
Temperature/Humidity : 23 deg.C / 59% RH
Engineer: : Keisuke Kawamura
Mode: : Tx 613.975MHz

Polarity	Frequency [MHz]	Detector	Reading [dBuV]	Ant.Fac. [dB/m]	Loss [dB]	Gain [dB]	Result [dBuV/m]	Limit [dBuV/m]	Margin [dB]	Remark
Hori	1227.950	AV	36.3	25.9	3.7	34.7	31.2	54.0	22.8	
Hori	1841.925	AV	36.5	27.8	2.7	33.2	33.8	54.0	20.2	
Hori	2455.900	AV	54.9	27.6	2.8	32.6	52.7	54.0	1.3	
Hori	3069.875	AV	39.8	29.2	3.2	32.2	40.0	54.0	14.0	
Hori	3683.850	AV	35.1	30.0	3.9	32.0	37.0	54.0	17.0	
Hori	4297.825	AV	41.7	30.4	4.7	31.9	44.9	54.0	9.1	
Hori	4911.800	AV	31.4	32.0	5.7	31.9	37.2	54.0	16.8	
Hori	5525.755	AV	30.1	32.3	6.8	32.0	37.2	54.0	16.8	
Hori	6139.750	AV	30.1	33.5	7.9	32.1	39.4	54.0	14.6	
Vert	1227.950	AV	41.0	25.9	3.7	34.7	35.9	54.0	18.1	
Vert	1841.925	AV	36.6	27.8	2.7	33.2	33.9	54.0	20.1	
Vert	2455.900	AV	53.0	27.6	2.8	32.6	50.8	54.0	3.2	
Vert	3069.875	AV	37.2	29.2	3.2	32.2	37.4	54.0	16.6	
Vert	3683.850	AV	34.3	30.0	3.9	32.0	36.2	54.0	17.8	
Vert	4297.825	AV	39.9	30.4	4.7	31.9	43.1	54.0	10.9	
Vert	4911.800	AV	31.6	32.0	5.7	31.9	37.4	54.0	16.6	
Vert	5525.755	AV	29.8	32.3	6.8	32.0	36.9	54.0	17.2	
Vert	6139.750	AV	31.6	33.5	7.9	32.1	40.9	54.0	13.2	

Result = Reading + Ant Factor + Loss (Cable+Attenuator+Filter-Distance factor) - Gain(Amplifier)