







RADIO TEST REPORT

Test Report No. 14202035S-B-R1

Customer	NIHON KOHDEN CORPORATION
Description of EUT	SDIO Wireless Module
Model Number of EUT	SX-SDMAC
FCC ID	B6BGZ-1XXP2
Test Regulation	FCC Part 15 Subpart C: 2021
Test Result	Complied (Refer to SECTION 3)
Issue Date	June 24, 2022
Remarks	Average Output Power only

Representative Test Engineer	Approved By
	
Kenichi Adachi Engineer	Toyokazu Imamura Leader
 	
CERTIFICATE 1266.03	
<input type="checkbox"/> The testing in which "Non-accreditation" is displayed is outside the accreditation scopes in UL Japan, Inc.	
<input checked="" type="checkbox"/> There is no testing item of "Non-accreditation".	

Report Cover Page - Form-ULID-003532 (DCS:13-EM-F0429) Issue# 20.0

ANNOUNCEMENT

- This test report shall not be reproduced in full or partial, without the written approval of UL Japan, Inc.
- The results in this report apply only to the sample tested.
- This sample tested is in compliance with the limits of the above regulation.
- The test results in this test report are traceable to the national or international standards.
- This test report must not be used by the customer to claim product certification, approval, or endorsement by the A2LA accreditation body.
- This test report covers Radio technical requirements.
It does not cover administrative issues such as Manual or non-Radio test related Requirements. (if applicable)
- The all test items in this test report are conducted by UL Japan, Inc Shonan EMC Lab.
- The opinions and the interpretations to the result of the description in this report are outside scopes where UL Japan, Inc. has been accredited.
- The information provided from the applicant for this report is identified in Section 1.
- For test report(s) referred in this report, the latest version (including any revisions) is always referred.

REVISION HISTORY

Original Test Report No.: 14202035S-B

This report is a revised version of 14202035S-B. 14202035S-B is replaced with this report.

Revision	Test Report No.	Date	Page Revised Contents
- (Original)	14202035S-B	March 29, 2022	-
1	14202035S-B-R1	June 24, 2022	p.5: Additional Receipt Date & Test Date. p.6: Replaced to the power value to retried data. p.8: Additional software information that used at June 15, 2022. p.12: Replaced to the retried data (at June 15, 2022). p.16-p.17: Additional the table of test instruments of at June 15, 2022. p.18-p.19: Additional the photo at June 15, 2022.

Reference: Abbreviations (Including words undescribed in this report)

A2LA	The American Association for Laboratory Accreditation	ICES	Interference-Causing Equipment Standard
AC	Alternating Current	IEC	International Electrotechnical Commission
AFH	Adaptive Frequency Hopping	IEEE	Institute of Electrical and Electronics Engineers
AM	Amplitude Modulation	IF	Intermediate Frequency
Amp, AMP	Amplifier	ILAC	International Laboratory Accreditation Conference
ANSI	American National Standards Institute	ISED	Innovation, Science and Economic Development Canada
Ant, ANT	Antenna	ISO	International Organization for Standardization
AP	Access Point	JAB	Japan Accreditation Board
ASK	Amplitude Shift Keying	LAN	Local Area Network
Atten., ATT	Attenuator	LIMS	Laboratory Information Management System
AV	Average	MCS	Modulation and Coding Scheme
BPSK	Binary Phase-Shift Keying	MRA	Mutual Recognition Arrangement
BR	Bluetooth Basic Rate	N/A	Not Applicable
BT	Bluetooth	NIST	National Institute of Standards and Technology
BT LE	Bluetooth Low Energy	NS	No signal detect.
BW	BandWidth	NSA	Normalized Site Attenuation
Cal Int	Calibration Interval	NVLAP	National Voluntary Laboratory Accreditation Program
CCK	Complementary Code Keying	OBW	Occupied Band Width
Ch., CH	Channel	OFDM	Orthogonal Frequency Division Multiplexing
CISPR	Comite International Special des Perturbations Radioelectriques	P/M	Power meter
CW	Continuous Wave	PCB	Printed Circuit Board
DBPSK	Differential BPSK	PER	Packet Error Rate
DC	Direct Current	PHY	Physical Layer
D-factor	Distance factor	PK	Peak
DFS	Dynamic Frequency Selection	PN	Pseudo random Noise
DQPSK	Differential QPSK	PRBS	Pseudo-Random Bit Sequence
DSSS	Direct Sequence Spread Spectrum	PSD	Power Spectral Density
EDR	Enhanced Data Rate	QAM	Quadrature Amplitude Modulation
EIRP, e.i.r.p.	Equivalent Isotropically Radiated Power	QP	Quasi-Peak
EMC	ElectroMagnetic Compatibility	QPSK	Quadri-Phase Shift Keying
EMI	ElectroMagnetic Interference	RBW	Resolution Band Width
EN	European Norm	RDS	Radio Data System
ERP, e.r.p.	Effective Radiated Power	RE	Radio Equipment
EU	European Union	RF	Radio Frequency
EUT	Equipment Under Test	RMS	Root Mean Square
Fac.	Factor	RSS	Radio Standards Specifications
FCC	Federal Communications Commission	Rx	Receiving
FHSS	Frequency Hopping Spread Spectrum	SA, S/A	Spectrum Analyzer
FM	Frequency Modulation	SG	Signal Generator
Freq.	Frequency	SVSWR	Site-Voltage Standing Wave Ratio
FSK	Frequency Shift Keying	TR	Test Receiver
GFSK	Gaussian Frequency-Shift Keying	Tx	Transmitting
GNSS	Global Navigation Satellite System	VBW	Video BandWidth
GPS	Global Positioning System	Vert.	Vertical
Hori.	Horizontal	WLAN	Wireless LAN

CONTENTS	PAGE
SECTION 1: Customer Information.....	5
SECTION 2: Equipment Under Test (EUT).....	5
SECTION 3: Test results	6
SECTION 4: Operation of EUT during testing.....	8
SECTION 5: Antenna Terminal Conducted Tests.....	11
APPENDIX 1: Test Data	12
Average Output Power.....	12
Duty cycle.....	13
APPENDIX 2: Test Instruments.....	16
APPENDIX 3: Photographs of Test Setup.....	18
Antenna Terminal Conducted Tests.....	18

SECTION 1: Customer Information

Company Name	NIHON KOHDEN CORPORATION
Address	1-31-4, Nishiochiai, Shinjuku-ku, Tokyo, 161-8560, Japan
Telephone Number	+81-3-5996-8354
Contact Person	Yuki Ayama

The information provided from the customer is as follows;

- Customer, Description of EUT, Model Number of EUT, FCC ID on the cover and other relevant pages
- Operating/Test Mode(s) (Mode(s)) on all the relevant pages
- SECTION 1: Customer Information
- SECTION 2: Equipment Under Test (EUT) other than the Receipt Date and Test Date
- SECTION 4: Operation of EUT during testing
- * The laboratory is exempted from liability of any test results affected from the above information in SECTION 2 and 4.

SECTION 2: Equipment Under Test (EUT)

2.1 Identification of EUT

Description	SDIO Wireless Module
Model Number	SX-SDMAC
Serial Number	Refer to SECTION 4.2
Condition	Production prototype (Not for Sale: This sample is equivalent to mass-produced items.)
Modification	No Modification by the test lab
Receipt Date	for duty chart measurement: March 4, 2022, for power measurement: June 15, 2022
Test Date	March 17, 2022 to June 15, 2022

2.2 Product Description

General Specification

Rating	DC 1.2 V (Host equipment: DC 3 V)
Operating temperature	-10 deg. C to 70 deg. C

Radio Specification

WLAN (IEEE802.11a/11b/11g/11n-20)

Equipment Type	Transceiver
Frequency of Operation	2412 MHz to 2462 MHz 5180 MHz to 5240 MHz 5260 MHz to 5320 MHz 5500 MHz to 5720 MHz 5745 MHz to 5825 MHz
Type of Modulation	DSSS, OFDM
Antenna Type	Mini-Nanoblade antenna: Laird Technologies Stand Alone antenna: Molex
Antenna Gain: G _{ANT}	Mini-Nanoblade antenna: 2.5 dBi (2.4 GHz), 4.8 dBi (5 GHz) Stand Alone antenna: 3.0 dBi (2.4 GHz), 4.6 dBi (5 GHz)

* The table shows the specification of the case that the EUT is installed in host device.

Rate of WLAN 11b mode is used between 5.5 Mbps and 11 Mbps (not used 1 Mbps and 2 Mbps) when the EUT is installed in host device.

SECTION 3: Test results

3.1 Test results

KDB 447498D01 (v06) has the following exclusion for portable devices:

This device $f = 2.48$ GHz, distance = 5 mm (minimum separation distance: 5 mm was used in the calculation) and the measured maximum average output power was 2 mW.

So for this device:

$2 \text{ mW [measured maximum average output power]} / 5 \text{ mm [minimum separation distance]} * (\text{Square root } (2.48)) = 0.6$

This is less than 3.0, so no SAR is required.

Note: UL Japan's Work Procedures No. ULID-003593 (13-EM-W0422).

3.2 Uncertainty

There is no applicable rule of uncertainty in this applied standard. Therefore, the following results are derived depending on whether or not laboratory uncertainty is applied.

The following uncertainties have been calculated to provide a confidence level of 95 % using a coverage factor $k=2$.
Shonan EMC Lab.

Antenna terminal test	Uncertainty (+/-)
Power Measurement above 1 GHz (Average Detector)_SPM-06	1.2 dB
Power Measurement above 1 GHz (Peak Detector)_SPM-06	2.0 dB
Power Measurement above 1 GHz (Average Detector)_SPM-07	1.2 dB
Power Measurement above 1 GHz (Peak Detector)_SPM-07	1.3 dB
Power Measurement above 1 GHz (Average Detector)_SPM-13	1.3 dB
Power Measurement above 1 GHz (Peak Detector)_SPM-13	1.3 dB
Duty cycle and Time Measurement	0.27 %

3.3 Test Location

UL Japan, Inc. Shonan EMC Lab.

1-22-3, Megumigaoka, Hiratsuka-shi, Kanagawa-ken 259-1220 JAPAN

Telephone: +81 463 50 6400, Facsimile: +81 463 50 6401

A2LA Certificate Number: 1266.03

(FCC test firm registration number: 626366, ISED lab company number: 2973D / CAB identifier: JP0001)

Test site	IC Registration Number	Width x Depth x Height (m)	Size of reference ground plane (m) / horizontal conducting plane	Maximum measurement distance
No.1 Semi-anechoic chamber	2973D-1	20.6 x 11.3 x 7.65	20.6 x 11.3	10 m
No.2 Semi-anechoic chamber	2973D-2	20.6 x 11.3 x 7.65	20.6 x 11.3	10 m
No.3 Semi-anechoic chamber	2973D-3	12.7 x 7.7 x 5.35	12.7 x 7.7	5 m
No.4 Semi-anechoic chamber	-	8.1 x 5.1 x 3.55	8.1 x 5.1	-
No.1 Shielded room	-	6.8 x 4.1 x 2.7	6.8 x 4.1	-
No.2 Shielded room	-	6.8 x 4.1 x 2.7	6.8 x 4.1	-
No.3 Shielded room	-	6.3 x 4.7 x 2.7	6.3 x 4.7	-
No.4 Shielded room	-	4.4 x 4.7 x 2.7	4.4 x 4.7	-
No.5 Shielded room	-	7.8 x 6.4 x 2.7	7.8 x 6.4	-
No.6 Shielded room	-	7.8 x 6.4 x 2.7	7.8 x 6.4	-
No.8 Shielded room	-	3.45 x 5.5 x 2.4	3.45 x 5.5	-
No.1 Measurement room	-	2.55 x 4.1 x 2.5	-	-

3.4 Test Data, Test Instruments, and Test Set Up

Refer to APPENDIX.

SECTION 4: Operation of EUT during testing

4.1 Operating Mode(s)

Test operating mode was determined as follows according to “Section 1 of 6 802.11 a/b/g/n testing - Managing Complex Regulatory Approvals - ” of TCB Council Workshop October 2009.

Mode	Remarks*
IEEE 802.11b (11b)	5.5 Mbps
IEEE 802.11g (11g)	6 Mbps
IEEE 802.11n 20 MHz BW (11n-20)	MCS 0
<p>*Power of the EUT was set by the software as follows; Power Setting: Fixed The EUT transmits vital signs to 4 monitors. The lowest rate was selected since ON time of transmitting is longest.</p> <p>*1) Software (Firmware): Ver.02-05B (Date: 2022.06.14, Storage location: EUT memory) (for power measurement) Ver.22-0227 (Date: 2022.03.10, Storage location: EUT memory) (for duty chart measurement)</p> <p>*2) After the pre-check of Antenna port 1 and Antenna port 2, the test was performed with the antenna that had higher power as a representative.</p> <p>*This setting of software is the worst case. Any conditions under the normal use do not exceed the condition of setting. In addition, end users cannot change the settings of the output power of the product.</p>	

*The Details of Operating Mode(s)

Test Item	Operating Mode	Tested Antenna	Tested Frequency
Average Output Power	Tx 11b Tx 11g Tx 11n-20	1	2412 MHz 2437 MHz 2462 MHz
Duty cycle	Tx 11b Tx 11g Tx 11n-20	1	2412 MHz

4.2 Configuration and Peripherals

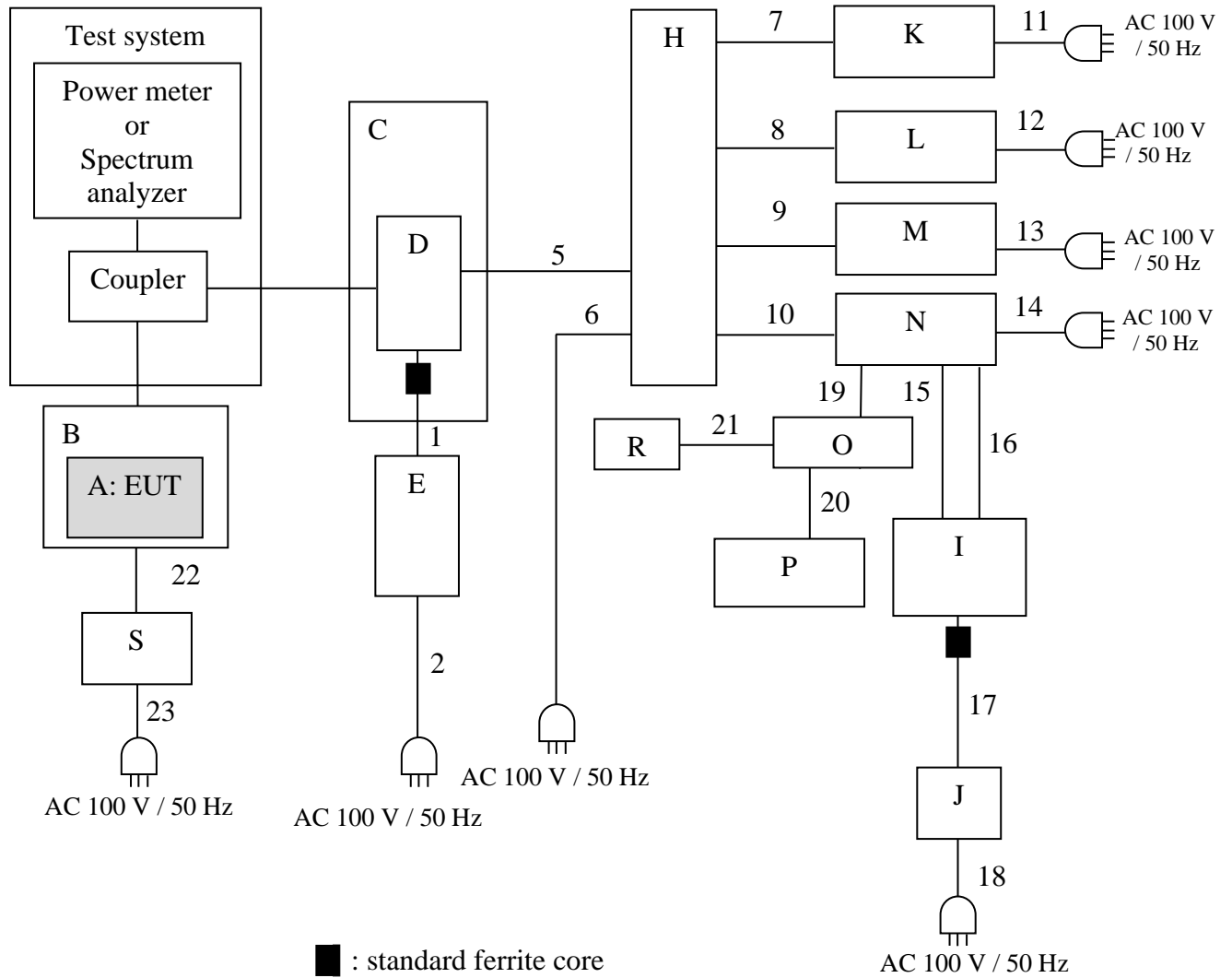

Description of EUT and Support Equipment

No.	Item	Model number	Serial number	Manufacturer	Remarks
A	SDIO Wireless Module	SX-SDMAC	84:25:3F:CB:AC:F6	silex technology, Inc.	EUT
B	Vital sign telemeter	GZ-130P OP No.30G	00399	Nihon Kohden	-
C	Shield tent	-	-	Sondecx	-
D	Wireless LAN access point	AIR-CAP3702E-A-K9	FTX18227609	Cisco Systems	-
E	AC adaptor	AA25480L	ALD02510FEW	Cisco Systems	-
H	HUB	CG-SW16TXR	1088620120700972 Rev.C1	Corega	-
I	LCD display unit	VL-611R	00617	Nihon Kohden	-
J	AC adaptor	HEMP100G-S120650-7L	3316007801F0- H-1246-002E	HiTRON	-
K	Central monitor	CNS-6201	Z4229766-01	Nihon Kohden	-
L	Central monitor	CNS-6201	02330	Nihon Kohden	-
M	Central monitor	CNS-6201	03237	Nihon Kohden	-
N	Central monitor	CNS-6201	01121	Nihon Kohden	-
O	USB HUB	A7513	22HA2ANE	ANKER	-
P	Keyboard	KB212-B	CN-0N290F-71581-530-0250-A01	DELL	-
R	Mouse	MS116t1	CN-0PRDV9-LO300-94B-0WKH	DELL	-
S	DC power supply	PW8-5ADPS	14086035	TEXIO	-

List of Cables Used

No.	Name	Length (m)	Shield		Remarks
			Cable	Connector	
1	DC	1.8	Unshielded	Unshielded	-
2	AC	1.7	Unshielded	Unshielded	-
5	LAN	2.0	Unshielded	Unshielded	-
6	AC	2.2	Unshielded	Unshielded	-
7	LAN	2.0	Unshielded	Unshielded	-
8	LAN	1.0	Unshielded	Unshielded	-
9	LAN	0.9	Unshielded	Unshielded	-
10	LAN	0.9	Unshielded	Unshielded	-
11	AC	2.5	Unshielded	Unshielded	-
12	AC	2.3	Unshielded	Unshielded	-
13	AC	2.5	Unshielded	Unshielded	-
14	AC	2.5	Unshielded	Unshielded	-
15	USB	2.5	Shielded	Shielded	-
16	DVI	2.5	Shielded	Shielded	-
17	DC	0.9	Unshielded	Unshielded	-
18	AC	1.7	Unshielded	Unshielded	-
19	USB	0.4	Shielded	Shielded	-
20	USB	2.1	Shielded	Shielded	-
21	USB	1.8	Shielded	Shielded	-
22	DC	0.04 + 1.9	Unshielded	Unshielded	-
23	AC	2.0	Unshielded	Unshielded	-

SECTION 5: Antenna Terminal Conducted Tests

Test Procedure

The tests were made with below setting connected to the antenna port.

Test	Span	RBW	VBW	Sweep time	Detector	Trace	Instrument Used
Average Output Power	-	-	-	Auto	Average	-	Power Meter (Sensor: 50 MHz BW)
Duty cycle	Zero	8 MHz	50 MHz	-	Peak	-	Spectrum analyzer

The test results and limit are rounded off to two decimals place, so some differences might be observed.
The equipment and cables were not used for factor 0 dB of the data sheets.

Test Data : **APPENDIX**

Test Result : **Pass**

APPENDIX 1: Test Data

Average Output Power

Test place	Shonan EMC Lab. No.1 Measurement Room
Date	June 15, 2022
Temperature / Humidity	24 deg. C / 54 % RH
Engineer	Kenichi Adachi
Mode	Tx

11b **5.5 Mbps** antenna port 1

Freq. [MHz]	Reading [dBm]	Cable Loss [dB]	Atten. Loss [dB]	Result (Time average)		Antenna gain [dBi]	Result (e.i.r.p)	
				[dBm]	[mW]		[dBm]	[mW]
2412	-10.62	1.79	10.04	1.21	1.32	3.00	4.21	2.63
2437	-9.84	1.79	10.04	2.00	1.58	3.00	5.00	3.16
2462	-9.22	1.80	10.04	2.62	1.83	3.00	5.62	3.65

11g **6 Mbps** antenna port 1

Freq. [MHz]	Reading [dBm]	Cable Loss [dB]	Atten. Loss [dB]	Result (Time average)		Antenna gain [dBi]	Result (e.i.r.p)	
				[dBm]	[mW]		[dBm]	[mW]
2412	-15.84	1.79	10.04	-4.01	0.40	3.00	-1.01	0.79
2437	-13.41	1.79	10.04	-1.57	0.70	3.00	1.43	1.39
2462	-15.72	1.80	10.04	-3.88	0.41	3.00	-0.88	0.82

11n-20 **MCS 0** antenna port 1

Freq. [MHz]	Reading [dBm]	Cable Loss [dB]	Atten. Loss [dB]	Result (Time average)		Antenna gain [dBi]	Result (e.i.r.p)	
				[dBm]	[mW]		[dBm]	[mW]
2412	-15.96	1.79	10.04	-4.13	0.39	3.00	-1.13	0.77
2437	-13.64	1.79	10.04	-1.80	0.66	3.00	1.20	1.32
2462	-16.27	1.80	10.04	-4.43	0.36	3.00	-1.43	0.72

Sample Calculation:

Result (Time average) = Reading + Cable Loss (including the cable(s) customer supplied) + Attenuator Loss

Result (e.i.r.p.) = Time average + Antenna gain

*The equipment and cables were not used for factor 0 dB of the data sheets.

The average output power was measured with the lowest order modulation and lowest data rate configuration in each IEEE 802.11 mode based on KDB 248227 D01.

Duty cycle

Test place Shonan EMC Lab. No.1 Measurement Room
Date March 18, 2022
Temperature / Humidity 24 deg. C / 33 % RH
Engineer Kenichi Adachi
Mode Tx 11b

11b 5.5 Mbps with antenna port 1 1 cycle = 256 ms

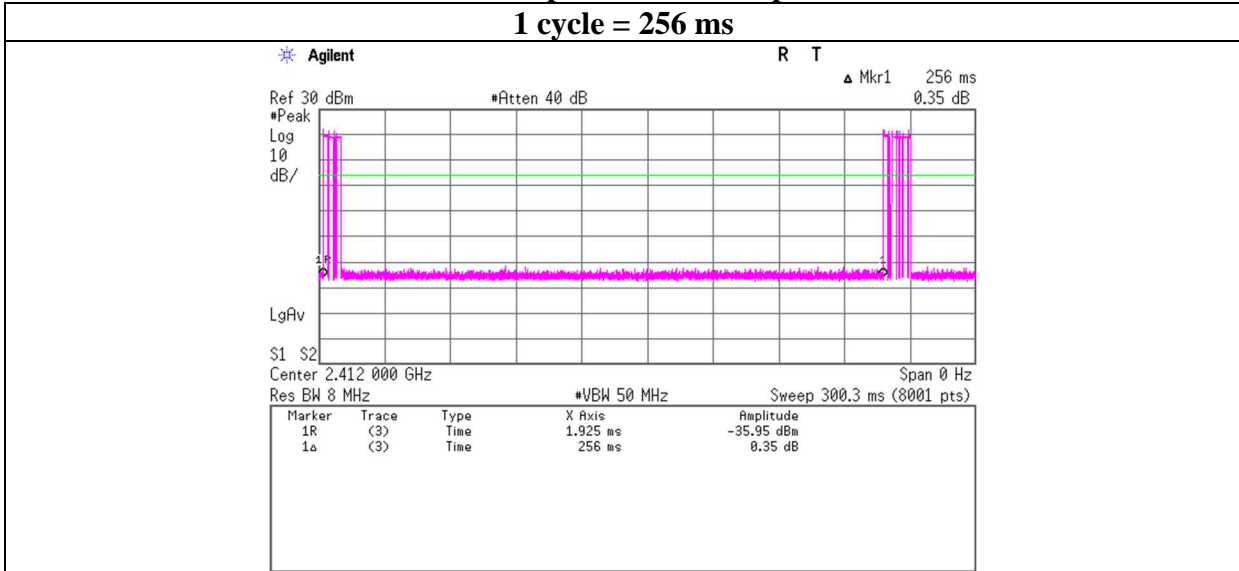

On time = 9.4666 ms (Duty cycle: 3.7 %)

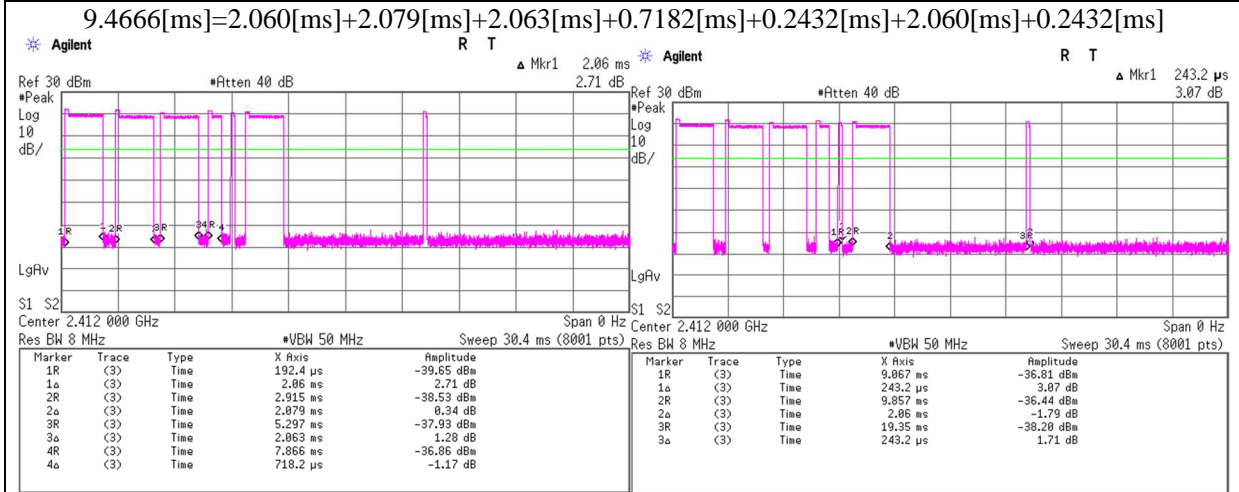

* Since the burst rate is not different between the channels, the data has been obtained on the representative channel.

Duty cycle

Test place Shonan EMC Lab. No.1 Measurement Room
Date March 17, 2022
Temperature / Humidity 24 deg. C / 37 % RH
Engineer Kenichi Adachi
Mode Tx 11g

11g 6 Mbps with antenna port 1 1 cycle = 256 ms

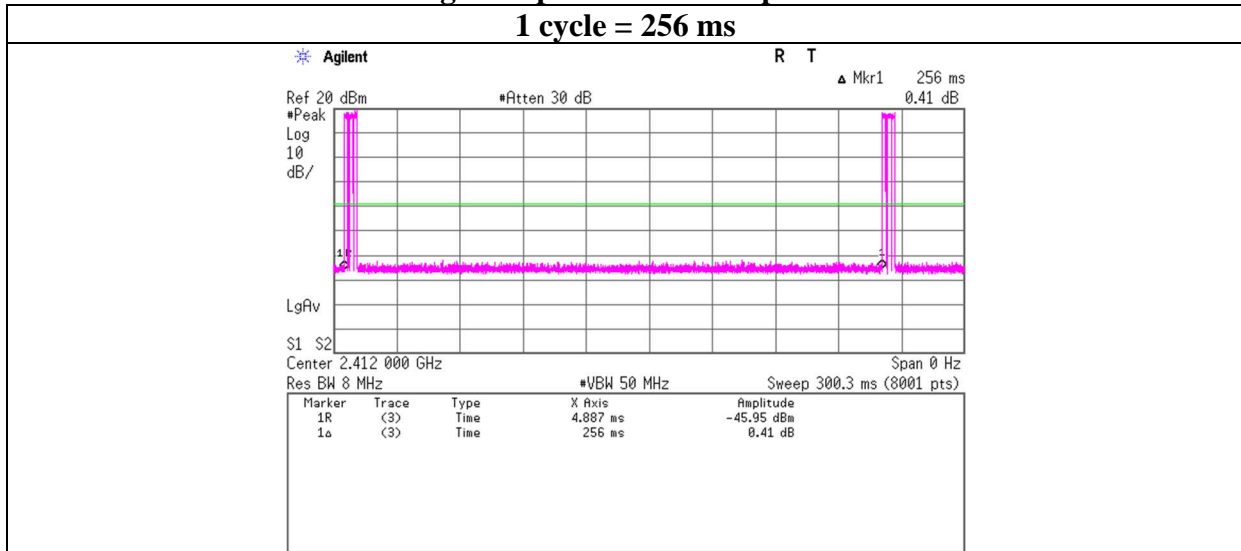

On time = 7.7105 ms (Duty cycle: 3.0 %)

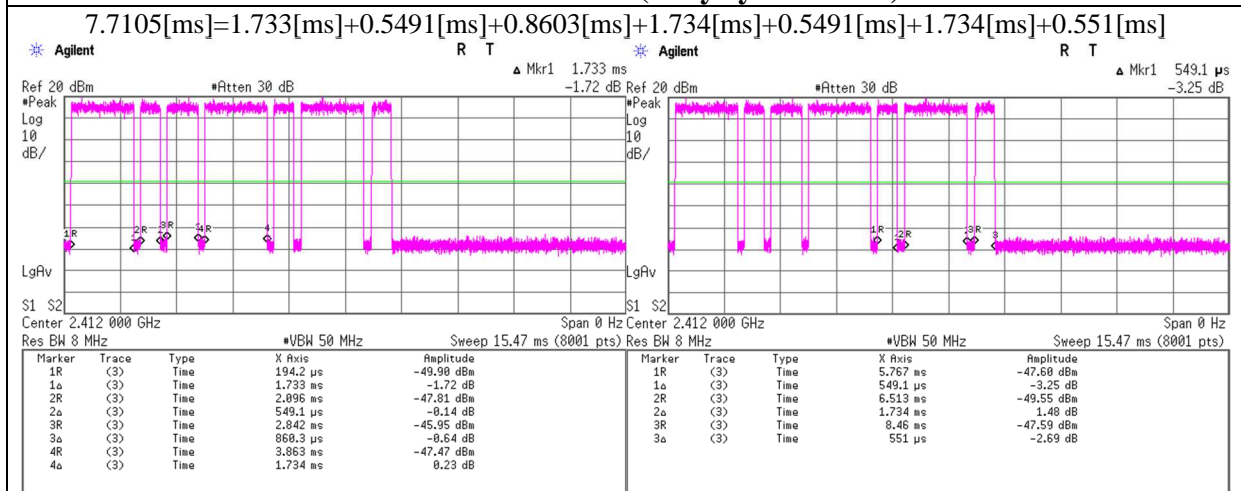

* Since the burst rate is not different between the channels, the data has been obtained on the representative channel.

Duty cycle

Test place	Shonan EMC Lab. No.1 Measurement Room
Date	March 17, 2022
Temperature / Humidity	24 deg. C / 37 % RH
Engineer	Kenichi Adachi
Mode	Tx 11n-20

11n-20 MCS 0 with antenna port 1 1 cycle = 256 ms

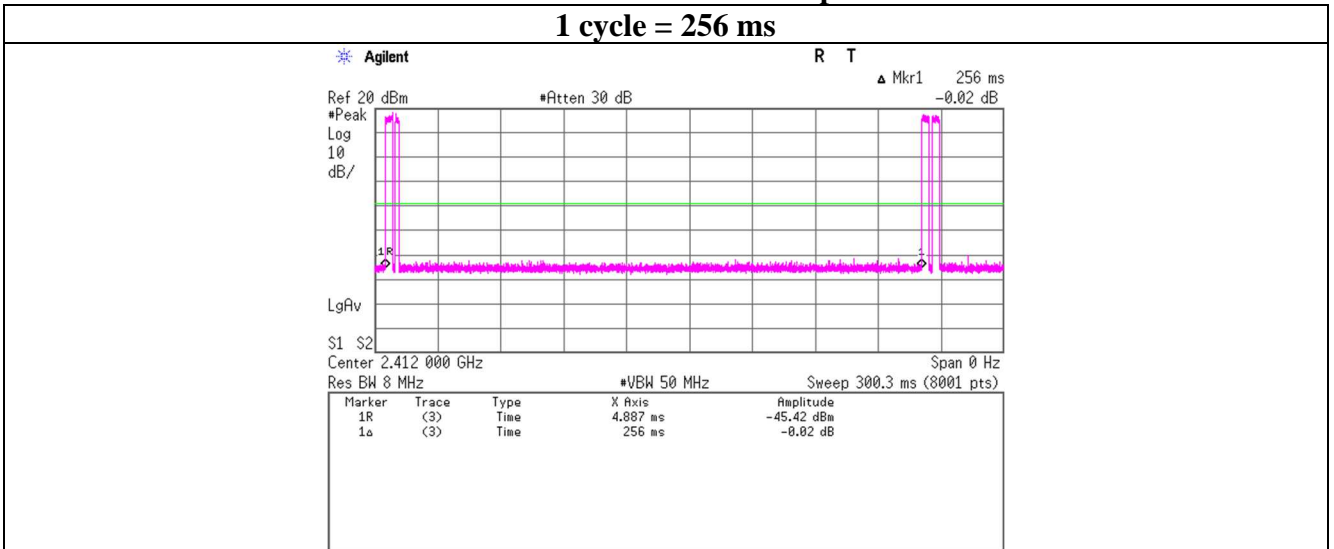

On time = 8.447 ms (Duty cycle: 3.3 %)

$$8.447[\text{ms}] = 3.687[\text{ms}] + 0.5297[\text{ms}] + 3.689[\text{ms}] + 0.5413[\text{ms}]$$

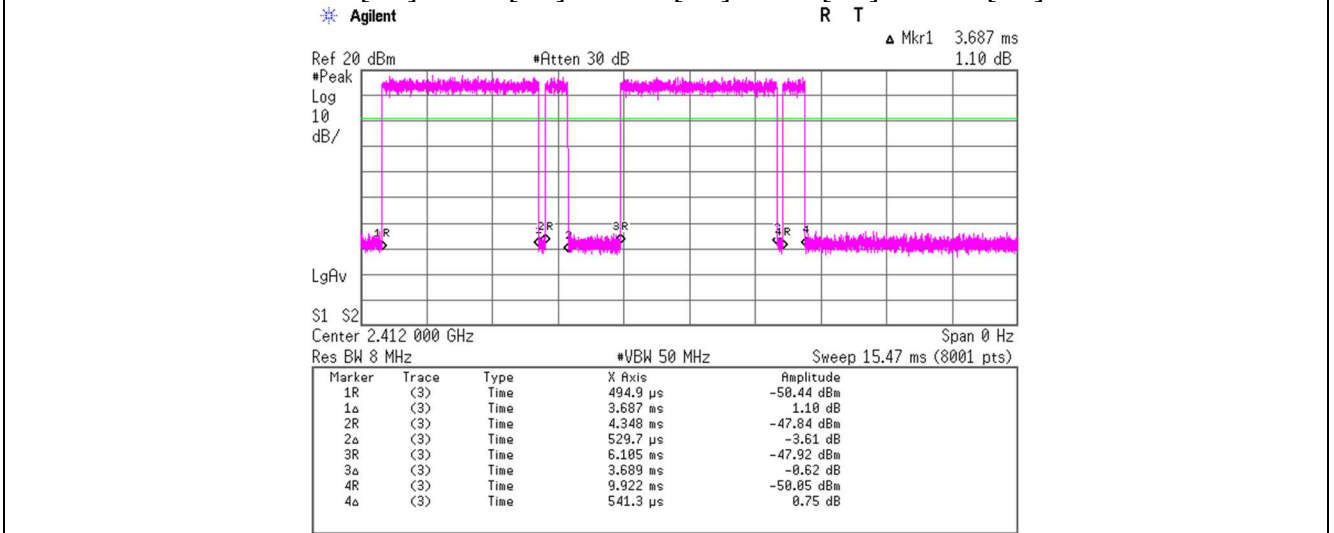

* Since the burst rate is not different between the channels, the data has been obtained on the representative channel.

APPENDIX 2: Test Instruments

Test Equipment (1/2)

(March 17 to 18, 2022)

Test Item	Local ID	LIMS ID	Description	Manufacturer	Model	Serial	Last Calibration Date	Cal Int
AT	KTS-08	145095	Digital Tester	SANWA	PC500	7019224	2021/04/26	12
AT	SCC-G12	145040	Coaxial Cable	Suhner	SUCOFLEX 102	30790/2	2021/03/04	12
AT	SCC-G63	196946	Coaxial Cable	Huber+Suhner	SUCOFLEX 102	803411/2	2021/03/01	12
AT	SCC-G64	196945	Coaxial Cable	Huber+Suhner	SUCOFLEX 102	803414/2	2021/03/01	12
AT	SCC-G67	196949	Coaxial Cable	Huber+Suhner	SUCOFLEX 102	803480/2	2021/03/01	12
AT	SCC-H21	197395	Microwave cable	RS Pro	R-132G7210 100CO	-	2021/04/08	12
AT	SCC-H23	199603	Microwave cable	RS Pro	R-132G7210 100CO	-	2021/06/14	12
AT	SDCPL-11	145439	Directional Coupler	Mini-Circuits	ZGDC35-93HP+	210	2021/07/01	12
AT	SOS-28	191846	Humidity Indicator	CUSTOM. Inc	CTH-201	-	2021/08/02	12
AT	SPM-07	146247	Power Meter	Keysight Technologies Inc	8990B	MY5100272	2021/05/25	12
AT	SPSS-04	146310	Power sensor	Keysight Technologies Inc	N1923A	MY5326009	2021/05/25	12
AT	SRENT-15	160899	Spectrum Analyzer	Keysight Technologies Inc	E4440A	MY46185516	2022/02/02	12
AT	SSAT-01	167151	Step Attenuator	Keysight Technologies Inc	8494B	MY42157639	2022/02/21	12
AT	SSAT-02	167152	Step Attenuator	Keysight Technologies Inc	8496B	MY42151198	2022/02/21	12
AT	STM-G9	171616	Terminator	Weinschel - API Technologies Corp	M1459A	89025	2021/05/18	12

*Hyphens for Last Calibration Date and Cal Int (month) are instruments that Calibration is not required (e.g. software), or instruments checked in advance before use.

The expiration date of the calibration is the end of the expired month.

As for some calibrations performed after the tested dates, those test equipment have been controlled by means of an unbroken chains of calibrations.

All equipment is calibrated with valid calibrations. Each measurement data is traceable to the national or international standards.

Test item: AT: Antenna Terminal Conducted

Test Equipment (2/2)

(June 15, 2022)

Test Item	Local ID	LIMS ID	Description	Manufacturer	Model	Serial	Last Calibration Date	Cal Int
AT	KTS-08	145095	Digital Tester	SANWA	PC500	7019224	2022/04/07	12
AT	SAT10-22	204926	Attenuator	Weinschel Corp.	54A-10	-	2022/02/21	12
AT	SCC-G24	145181	Coaxial Cable	Suhner	141PE	-	2021/07/01	12
AT	SCC-G52	179106	Coaxial Cable	Junkosha	MWX241-01000KMSKMS/B	1901Q061-R	2022/04/01	12
AT	SCC-G53	179107	Coaxial Cable	Junkosha	MWX241-01000KMSKMS/B	1901Q062-R	2022/04/01	12
AT	SCC-G54	179108	Coaxial Cable	Junkosha	MWX241-03000KMSKMS/B	1901Q033-R	2022/04/01	12
AT	SCC-H25	202919	Microwave cable	RS Pro	R-132G7210100CO	-	2021/11/10	12
AT	SCC-H27	202921	Microwave cable	RS Pro	R-132G7210100CO	-	2021/11/09	12
AT	SDCPL-11	145439	Directional Coupler	Mini-Circuits	ZGDC35-93HP+	210	2021/07/01	12
AT	SOS-28	191846	Humidity Indicator	CUSTOM. Inc	CTH-201	-	2021/08/02	12
AT	SPM-06	146267	Power Meter	Anritsu Corporation	ML2495A	850009	2022/05/24	12
AT	SPSC-08	146277	Power Splitters/Combiners	Mini-Circuits	ZFSC-2-10G+	-	2021/11/05	12
AT	SPSS-03	146309	Power sensor	Anritsu Corporation	MA2411B	917063	2022/05/24	12
AT	SRE-157	145693	Wireless LAN access point	Cisco Systems, Inc.	AIR-CAP3702E-A-K9	FTX18227609	-	-
AT	SRENT-09	150461	Spectrum Analyzer	Keysight Technologies Inc	E4440A	MY46186392	2022/03/14	12
AT	SSAT-01	167151	Step Attenuator	Keysight Technologies Inc	8494B	MY42157639	2022/02/21	12
AT	SSAT-02	167152	Step Attenuator	Keysight Technologies Inc	8496B	MY42151198	2022/02/21	12
AT	STM-G9	171616	Terminator	Weinschel - API Technologies Corp	M1459A	89025	2022/05/12	12

*Hyphens for Last Calibration Date and Cal Int (month) are instruments that Calibration is not required (e.g. software), or instruments checked in advance before use.

The expiration date of the calibration is the end of the expired month.

As for some calibrations performed after the tested dates, those test equipment have been controlled by means of an unbroken chains of calibrations.

All equipment is calibrated with valid calibrations. Each measurement data is traceable to the national or international standards.

Test item: AT: Antenna Terminal Conducted