

FCC and ISED Test Report

ACR Electronics Inc
EPIRB Model: RLB-44

In accordance with FCC 47 CFR Part 2, FCC 47
CFR Part 80, ISED RSS-182, ISED RSS-287 and
ISED RSS-GEN
(121.5 MHz Homing and AIS Locating Signal)

Prepared for: Ocean Signal Limited
Ocivan Way, Margate
CT9 4NN
United Kingdom



Add value.
Inspire trust.

FCC ID: B66ACR-RLB-44

IC: 1322A-ACRRLB44E1E2

COMMERCIAL-IN-CONFIDENCE

Document 75953445-04 Issue 01

SIGNATURE

| NAME | JOB TITLE | RESPONSIBLE FOR | ISSUE DATE |
|-----------------|----------------------|----------------------|-----------------|
| Matthew Russell | Senior Engineer (RF) | Authorised Signatory | 13 October 2022 |

Signatures in this approval box have checked this document in line with the requirements of TÜV SÜD document control rules.

ENGINEERING STATEMENT

The measurements shown in this report were made in accordance with the procedures described on test pages. All reported testing was carried out on a sample equipment to demonstrate limited compliance with FCC 47 CFR Part 2, FCC 47 CFR Part 80, ISED RSS-182, ISED RSS-287 and ISED RSS-GEN. The sample tested was found to comply with the requirements defined in the applied rules.

| RESPONSIBLE FOR | NAME | DATE | SIGNATURE |
|-----------------|-----------------|-----------------|-----------|
| Testing | Matthew Sellers | 13 October 2022 | |

FCC Accreditation
90987 Octagon House, Fareham Test Laboratory

ISED Accreditation
12669A Octagon House, Fareham Test Laboratory

EXECUTIVE SUMMARY

A sample of this product was tested and found to be compliant with FCC 47 CFR Part 2: 2020, FCC 47 CFR Part 80: 2020, ISED RSS-182: Issue 6 (2021-06), ISED RSS-287: Issue 2 (2014-03) + A1 (2021-06) and ISED RSS-GEN: Issue 5 (2018-04) + A2 (2021-02) for the tests detailed in section 1.3.



DISCLAIMER AND COPYRIGHT

This non-binding report has been prepared by TÜV SÜD with all reasonable skill and care. The document is confidential to the potential Client and TÜV SÜD. No part of this document may be reproduced without the prior written approval of TÜV SÜD. © 2022 TÜV SÜD. This report relates only to the actual item/items tested.

ACCREDITATION

Our UKAS Accreditation does not cover opinions and interpretations and any expressed are outside the scope of our UKAS Accreditation. Results of tests not covered by our UKAS Accreditation Schedule are marked NUA (Not UKAS Accredited).

TÜV SÜD
is a trading name of TÜV SÜD Ltd
Registered in Scotland at East Kilbride,
Glasgow G75 0QF, United Kingdom
Registered number: SC215164

TÜV SÜD Ltd is a
TÜV SÜD Group Company

Phone: +44 (0) 1489 558100
Fax: +44 (0) 1489 558101
www.tuvsud.com/en

TÜV SÜD
Octagon House
Concorde Way
Fareham
Hampshire PO15 5RL
United Kingdom



Contents

| | | |
|----------------|---|------------|
| 1 | Report Summary | 2 |
| 1.1 | Report Modification Record..... | 2 |
| 1.2 | Introduction..... | 2 |
| 1.3 | Brief Summary of Results | 3 |
| 1.4 | Application Form | 4 |
| 1.5 | Product Information | 5 |
| 1.6 | Deviations from the Standard..... | 5 |
| 1.7 | EUT Modification Record | 5 |
| 1.8 | Test Location | 6 |
| 2 | Test Details | 7 |
| 2.1 | Bandwidths | 7 |
| 2.2 | Transmitter Frequency Tolerances | 10 |
| 2.3 | Spurious Emissions at Antenna Terminals | 13 |
| 2.4 | Radiated Spurious Emissions | 18 |
| 2.5 | Modulation Requirements | 26 |
| 2.6 | Bandwidths | 31 |
| 2.7 | Transmitter Frequency Tolerances | 34 |
| 2.8 | Spurious Emissions at Antenna Terminals | 37 |
| 2.9 | Radiated Spurious Emissions | 41 |
| 2.10 | Modulation Characteristics | 46 |
| 2.11 | Spectrum Characteristics | 50 |
| 3 | Photographs | 52 |
| 3.1 | Test Setup Photographs | 52 |
| 4 | Measurement Uncertainty | 58 |
| ANNEX A | Test Results from 75953445 Report 05 | A.2 |
| ANNEX B | Manufacturer Supplied Documents | B.2 |



1 Report Summary

1.1 Report Modification Record

Alterations and additions to this report will be issued to the holders of each copy in the form of a complete document.

| Issue | Description of Change | Date of Issue |
|-------|-----------------------|-----------------|
| 1 | First Issue | 13 October 2022 |

Table 1

1.2 Introduction

| | |
|-------------------------------|--|
| Applicant | Ocean Signal Limited |
| Manufacturer | ACR Electronics Inc |
| Model Number(s) | RLB-44 |
| Serial Number(s) | TA000022 |
| Hardware Version(s) | Issue 01.00 |
| Firmware Version(s) | Issue 00.03.00 |
| Number of Samples Tested | 1 |
| Test Specification/Issue/Date | FCC 47 CFR Part 2: 2020 FCC 47 CFR Part 80: 2020 ISED RSS-182: Issue 6 (2021-06) ISED RSS-287: Issue 2 (2014-03) + A1 (2021-06) ISED RSS-GEN: Issue 5 (2018-04) + A2 (2021-02) |
| Order Number | 13429 |
| Date | 16-September-2021 |
| Date of Receipt of EUT | 30-March-2022 |
| Start of Test | 15-June-2022 |
| Finish of Test | 18-July-2022 |
| Name of Engineer(s) | Matthew Sellers |
| Related Document(s) | ANSI C63.26: 2015 |



1.3 Brief Summary of Results

A brief summary of the tests carried out in accordance with FCC 47 CFR Part 2, FCC 47 CFR Part 80, ISED RSS-182, ISED RSS-287 and ISED RSS-GEN is shown below.

| Section | Specification Clause | | | | | Test Description | Result | Comments/Base Standard |
|--|----------------------|-------------------|---------|---------|---------|---|--------|------------------------|
| | Part 2 | Part 80 | RSS-182 | RSS-287 | RSS-GEN | | | |
| Configuration and Mode: AIS | | | | | | | | |
| 2.1 | 2.1049 | 80.205 | - | - | 6.7 | Bandwidths | Pass | |
| 2.2 | 2.1055 | 80.209 | 5.5 | - | 6.11 | Transmitter Frequency Tolerances | Pass | |
| 2.3 | 2.1051 | 80.211 | 5.9 | - | 6.13 | Spurious Emissions at Antenna Terminals | Pass | |
| 2.4 | 2.1051 | 80.211 | 5.9 | - | 6.13 | Radiated Spurious Emissions | Pass | |
| 2.5 | 2.1047 | 80.213 | 5.4 | - | - | Modulation Requirements | Pass | |
| 2.6 | 2.1046 | 80.215 | 5.6 | - | 6.12 | Transmitter Power | - | Refer to Annex A |
| Configuration and Mode: 121.5 MHz Homing Transmitter | | | | | | | | |
| 2.7 | 2.1049 | 80.205 | - | - | 6.7 | Bandwidths | Pass | |
| 2.8 | 2.1055 | 80.209 | - | 7.4.2 | 6.11 | Transmitter Frequency Tolerances | Pass | |
| 2.9 | 2.1051 | 80.211 | - | 7.4.4 | 6.13 | Spurious Emissions at Antenna Terminals | Pass | |
| 2.10 | 2.1053 | 80.211 | - | 7.4.4 | 6.13 | Radiated Spurious Emissions | Pass | |
| 2.11 | 2.1047 | 80.213 or 80.1061 | - | 7.4.1 | - | Modulation Characteristics | Pass | |
| 2.12 | 2.1046 | 80.215 | - | 7.4.3 | 6.12 | Transmitter Power | - | Refer to Annex A |
| 2.13 | - | - | - | 7.4.5 | - | Spectrum Characteristics | Pass | |

Table 2



1.4 Application Form

| MAIN EUT | |
|---|---|
| MANUFACTURING DESCRIPTION | Emergency Position Indicating Radio Beacon |
| MANUFACTURER | Ocean Signal Ltd, ACR Electronics Inc. |
| MODEL | RLB-44 (GlobalFix V5) |
| PART NUMBER | 900S-03858 |
| HARDWARE VERSION | Issue 01.00 |
| SOFTWARE VERSION | Not Applicable |
| FIRMWARE VERSION | 500S-03885 Issue 00.03.00 |
| PSU VOLTAGE/FREQUENCY/CURRENT | 9V |
| HIGHEST INTERNALLY GENERATED FREQUENCY | 406.031 MHz |
| FCC ID (if applicable) | B66ACR-RLB-44 |
| INDUSTRY CANADA ID (if applicable) | 1322A-ACRRLB44E1E2 |
| TECHNICAL DESCRIPTION (a brief technical description of the intended use and operation) | Emergency Position Indicating Radio Beacon incorporating 162 MHz AIS Man Overboard positioning, 406MHz Cospas Sarsat Satellite rescue and 121.5MHz homing capabilities. |
| COUNTRY OF ORIGIN | UK and USA |
| RF CHARACTERISTICS (if applicable) | |
| TRANSMITTER FREQUENCY OPERATING RANGE (MHz) | 121.5MHz, 161.975MHz, 162.025 MHz & 406.031MHz |
| RECEIVER FREQUENCY OPERATING RANGE (MHz) | N/A |
| INTERMEDIATE FREQUENCIES | N/A |
| EMISSION DESIGNATOR(S): https://fccid.io/Emissions-Designator/ | 3K20A3X, 16K0GXW, 16K0G1D |
| MODULATION TYPES: (i.e. GMSK, QPSK) | Swept tone AM, GMSK, BPSK |
| OUTPUT POWER (W or dBm) | 16 ±2dBm (121.5MHz), 31.5 ±0.5 dBm (AIS), 37dBm (406MHz) |

Table 3

I hereby declare that the information supplied is correct and complete.

Name: Mark Newton
 Position held: Approvals Manager
 Date: 15-June-2022



1.5 Product Information

1.5.1 Technical Description

The RLB-44 is a 406 MHz emergency locating beacon with a 121.5 MHz homing transmitter and AIS signal locating function; the EUT is designed to be used to alert emergency services to aide rescue in grave and imminent danger.

1.6 Deviations from the Standard

No deviations from the applicable test standard were made during testing.

1.7 EUT Modification Record

The table below details modifications made to the EUT during the test programme.

The modifications incorporated during each test are recorded on the appropriate test pages.

| Modification State | Description of Modification still fitted to EUT | Reasons for modification | Date Modification Fitted |
|--|--|--|--------------------------|
| Model: RLB-44, Serial Number: TA000022, TA000007 | | | |
| 0 - All test samples | As supplied by manufacturer. Hardware: 01.00 Firmware: 00.10.00 Software: N/A | N/A | Not Applicable |
| 1 - All test samples | Hardware: 01.00 Firmware: 00.10.00 Software: N/A | Update to fix GNSS Timings via factory NVM settings and AIS Timings (self test burst) via factory NVM settings | 22-February-2022 |
| 2 - All test samples | Hardware: 01.00 Firmware: 00.30.00 Software: N/A | Change to AIS stack for True Heading parameter | 07-April-2022 |
| 3 - TA000016 only | Hardware: 01.00 Firmware: 00.30.00 Software: N/A | PCB mount – not applicable to this test report | 22-June-2022 |
| 4 - TA000007 only | Hardware: 02.00 Firmware: 00.03.00 Software: N/A | Change to C164 - See Annex B for information | 18-July-2022 |

Table 4



1.8 Test Location

TÜV SÜD conducted the following tests at our Fareham Test Laboratory.

| Test Name | Name of Engineer(s) | Accreditation |
|--|---------------------|---------------|
| Configuration and Mode: AIS | | |
| Bandwidths | Matthew Sellers | UKAS |
| Transmitter Frequency Tolerances | Matthew Sellers | UKAS |
| Spurious Emissions at Antenna Terminals | Matthew Sellers | UKAS |
| Radiated Spurious Emissions | Matthew Sellers | UKAS |
| Modulation Requirements | Matthew Sellers | UKAS |
| Configuration and Mode: 121.5 MHz Homing Transmitter | | |
| Bandwidths | Matthew Sellers | UKAS |
| Transmitter Frequency Tolerances | Matthew Sellers | UKAS |
| Spurious Emissions at Antenna Terminals | Matthew Sellers | UKAS |
| Radiated Spurious Emissions | Matthew Sellers | UKAS |
| Modulation Characteristics | Matthew Sellers | UKAS |
| Spectrum Characteristics | Matthew Sellers | UKAS |

Table 5

Office Address:

TÜV SÜD
Octagon House
Concorde Way
Fareham
Hampshire
PO15 5RL
United Kingdom



2 Test Details

2.1 Bandwidths

2.1.1 Specification Reference

FCC 47 CFR Part 2, Clause 2.1049
FCC 47 CFR Part 80, Clause 80.205
ISED RSS-GEN, Clause 6.7

2.1.2 Equipment Under Test and Modification State

RLB-44, S/N: TA000022 - Modification State 2

2.1.3 Date of Test

16-June-2022

2.1.4 Test Method

AIS

The test was applied in accordance with the test method requirements of FCC CFR 47 Part 80.205, Part 2.1049 and Industry Canada RSS-GEN Clause 6.7.

The EUT was transmitting at maximum power, modulated by the standard AIS test signals using PRBS packet payloads. The EUT was connected to a spectrum analyser via a cable and attenuator, the RBW of the spectrum analyser was set to at least 1% of the emission bandwidth, the occupied bandwidth measurement function of the analyser was used and the 99% bandwidth recorded.

The plots on the following pages show the resultant display from the Spectrum Analyser.

2.1.5 Environmental Conditions

| | |
|---------------------|---------|
| Ambient Temperature | 24.2 °C |
| Relative Humidity | 38.5 % |



2.1.6 Test Results

AIS

| Occupied Bandwidth (kHz) | |
|--------------------------|-------------|
| 161.975 MHz | 162.025 MHz |
| 9.497 | 9.500 |

Table 6 - Occupied Bandwidth Result

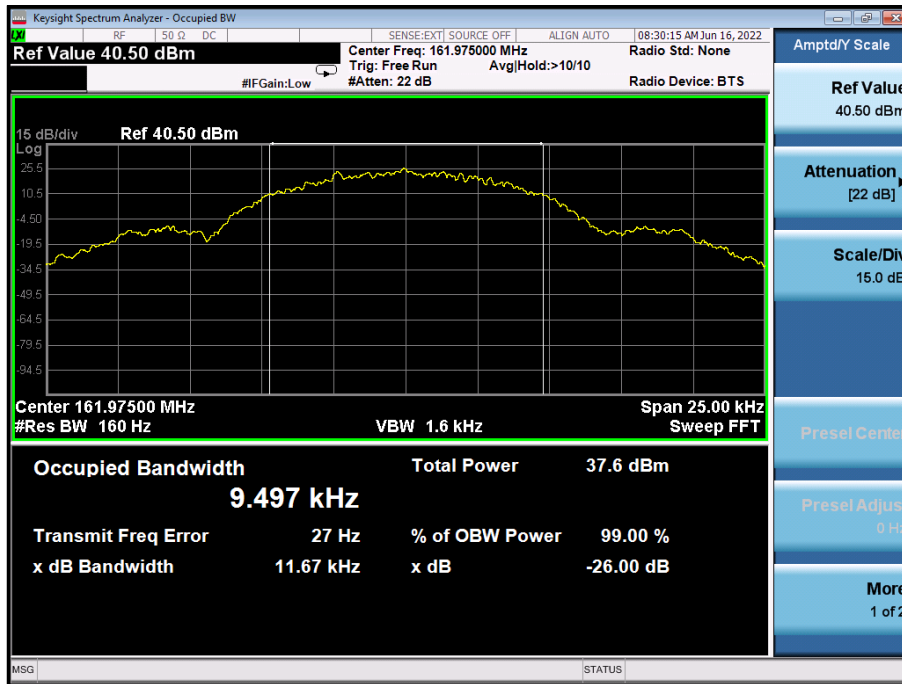

Figure 1 – 161.975 MHz Occupied Bandwidth



Figure 2 – 162.025 MHz Occupied Bandwidth

FCC 47 CFR Part 80, Limit Clause 80.205

Emission Designator: 16K0GXW (Note: Emission Designator for AIS not specified in Part 80.205)
 Authorised Bandwidth: < 20 kHz

2.1.7 Test Location and Test Equipment Used

This test was carried out in RF Laboratory 3.

| Instrument | Manufacturer | Type No. | TE No. | Calibration Period (months) | Calibration Expiry Date |
|------------------------|-----------------------|---------------------------|--------|-----------------------------|-------------------------|
| Attenuator (20dB, 10W) | Weinschel | 37-20-34 | 482 | 12 | 17-Jan-2023 |
| Hygrometer | Rotronic | I-1000 | 2891 | 12 | 04-Nov-2022 |
| Frequency Standard | Spectracom | SecureSync 1200-0408-0601 | 4393 | 6 | 30-Jun-2022 |
| PXA Signal Analyser | Keysight Technologies | N9030A | 4653 | 12 | 08-Mar-2023 |
| Cable (18 GHz) | Rosenberger | LU7-036-2000 | 5037 | - | O/P Mon |

Table 7

O/P Mon – Output Monitored using calibrated equipment



2.2 Transmitter Frequency Tolerances

2.2.1 Specification Reference

FCC 47 CFR Part 2, Clause 2.1055
FCC 47 CFR Part 80, Clause 80.209
ISED RSS-182, Clause 5.5
ISED RSS-GEN, Clause 6.11.

2.2.2 Equipment Under Test and Modification State

RLB-44, S/N: TA000022 - Modification State 2

2.2.3 Date of Test

17-June-2022 to 21-June-2022

2.2.4 Test Method

AIS

The EUT was transmitting at maximum power in turn on either, AIS channel. The EUT was modulated using the standard AIS test signal with PRBS packet payload. The EUT was connected to the spectrum analyser via a cable and attenuator. The external frequency reference of the spectrum analyser was locked to a 10 MHz rubidium frequency reference. The FM DEMOD function of the spectrum analyser was used which records the carrier frequency error. The temperature was varied from -30°C to +55°C in 10°C steps. At 20°C the voltage was also reduced to the manufacturer's declared operating battery endpoint voltage.

2.2.5 Environmental Conditions

| | |
|---------------------|----------------|
| Ambient Temperature | 24.9 - 27.9 °C |
| Relative Humidity | 33.6 - 34.0 % |



2.2.6 Test Results

AIS

| Voltage | Frequency Error (ppm) | |
|----------------------|-----------------------|-------------|
| | 161.975 MHz | 162.025 MHz |
| 5.5 V DC (End-Point) | -0.20 | -0.22 |
| 9.0 V DC (Nominal) | 0.34 | 0.41 |

Table 8 - Frequency Stability Under Voltage Variations

| Temperature | Frequency Error (ppm) | |
|-------------|-----------------------|-------------|
| | 161.975 MHz | 162.025 MHz |
| +55.0 °C | -0.28 | -0.3 |
| +50.0 °C | -0.07 | -0.09 |
| +40.0 °C | 0.10 | 0.09 |
| +30.0 °C | 0.29 | 0.16 |
| +20.0 °C | 0.34 | 0.41 |
| +10.0 °C | 0.28 | 0.25 |
| 0 °C | 0.28 | 0.33 |
| -10.0 °C | 0.14 | -0.14 |
| -20.0 °C | -0.44 | -0.38 |
| -30.0 °C | -0.46 | -0.56 |

Table 9 - Frequency Stability Under Temperature Variations

FCC 47 CFR Part 80, Limit Clause 80.209

± 10 ppm.

ISED RSS-182, Limit Clause 5.5

Coast Station: ±10.0 ppm for transmitter power less than 3 W.
 ±5.0 ppm for transmitter power between 3 W and 50 W.

Ship Station: ±10 ppm.



2.2.7 Test Location and Test Equipment Used

This test was carried out in RF Laboratory 3.

| Instrument | Manufacturer | Type No. | TE No. | Calibration Period (months) | Calibration Expiry Date |
|--------------------------|-----------------------|---------------------------|--------|-----------------------------|-------------------------|
| Attenuator (20dB, 10W) | Weinschel | 37-20-34 | 482 | 12 | 17-Jan-2023 |
| Hygrometer | Rotronic | I-1000 | 2891 | 12 | 04-Nov-2022 |
| Thermocouple Data Logger | Pico Technology Ltd | TC-08 | 3783 | 12 | 24-Jun-2022 |
| Frequency Standard | Spectracom | SecureSync 1200-0408-0601 | 4393 | 6 | 30-Jun-2022 |
| PXA Signal Analyser | Keysight Technologies | N9030A | 4653 | 12 | 08-Mar-2023 |
| Cable (18 GHz) | Rosenberger | LU7-036-2000 | 5037 | - | O/P Mon |
| Environmental Chamber | ACS | DY110TC | 5589 | - | O/P Mon |
| Signal Analyzer | Keysight Technologies | N9020B-ATO-43105 | 5742 | 12 | 03-Feb-2023 |

Table 10

O/P Mon – Output Monitored using calibrated equipment



2.3 Spurious Emissions at Antenna Terminals

2.3.1 Specification Reference

FCC 47 CFR Part 2, Clause 2.1051
FCC 47 CFR Part 80, Clause 80.211
ISED RSS-182, Clause 5.9
ISED RSS-GEN, Clause 6.13.

2.3.2 Equipment Under Test and Modification State

RLB-44, S/N: TA000022 - Modification State 2

2.3.3 Date of Test

16-June-2022 & 25-July-2022

2.3.4 Test Method

AIS

For emissions where the frequency is removed less than 250% of the authorized bandwidth measurements were performed conducted as follows:

The EUT was connected to a spectrum analyser via a cable and attenuator. The path loss between the EUT and analyser was calibrated using a network analyser and entered into the spectrum analyser as a reference level offset. The reference level for the mask was established with an RBW approximately 2 or 3 times the emission bandwidth. The RBW was then reduced to at least 1% of the emission bandwidth, with a VBW of 3 times RBW. The mask as per FCC CFR 47 Part 80.211 (f) was applied.

For emissions where the frequency is removed more than 250% of the authorized bandwidth measurements were performed both conducted and radiated as follows:

Conducted: A network analyser was used to measure the path loss and the worst case was entered as a reference level offset into the spectrum analyser. The EUT was connected to a spectrum analyser via an attenuator and cable. The spectrum analyser was configured with an RBW of 30 kHz with the trace set to max hold using a peak detector.

2.3.5 Environmental Conditions

| | |
|---------------------|---------|
| Ambient Temperature | 24.2 °C |
| Relative Humidity | 38.5 % |



2.3.6 Test Results

AIS



Figure 3 – 161.975 MHz - Transmitter Spectrum Mask

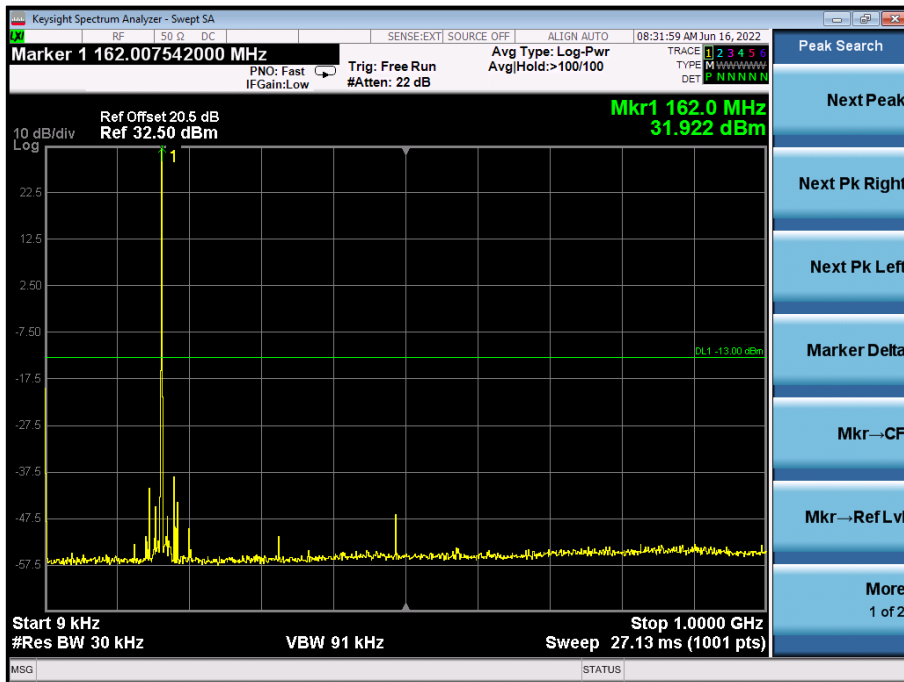

Figure 4 – 161.975 MHz - 9 kHz to 1 GHz

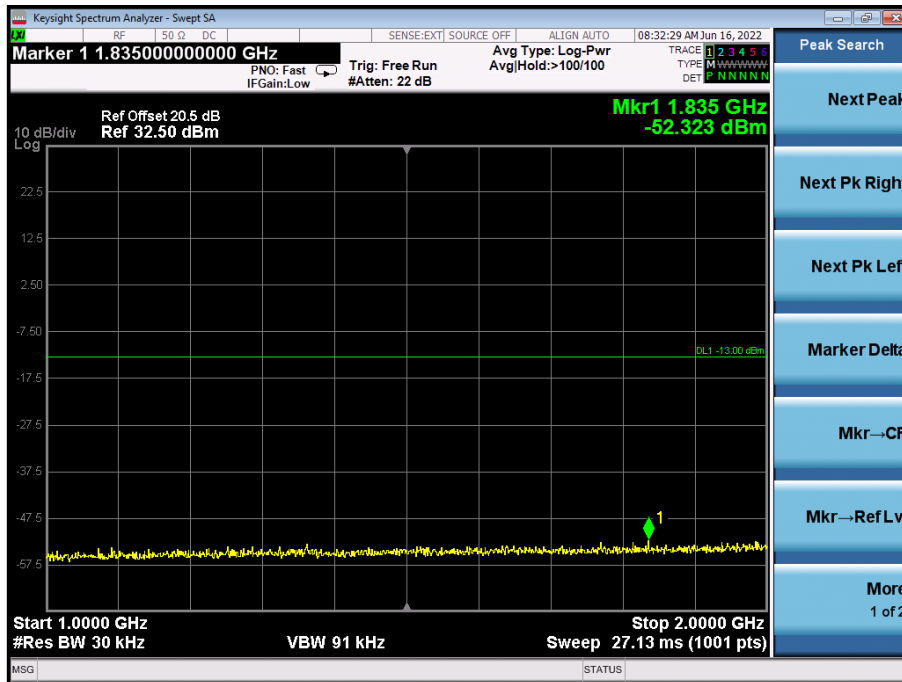

Figure 5 – 161.975 MHz - 1 GHz to 2 GHz



Figure 6 – 162.025 MHz - Transmitter Spectrum Mask

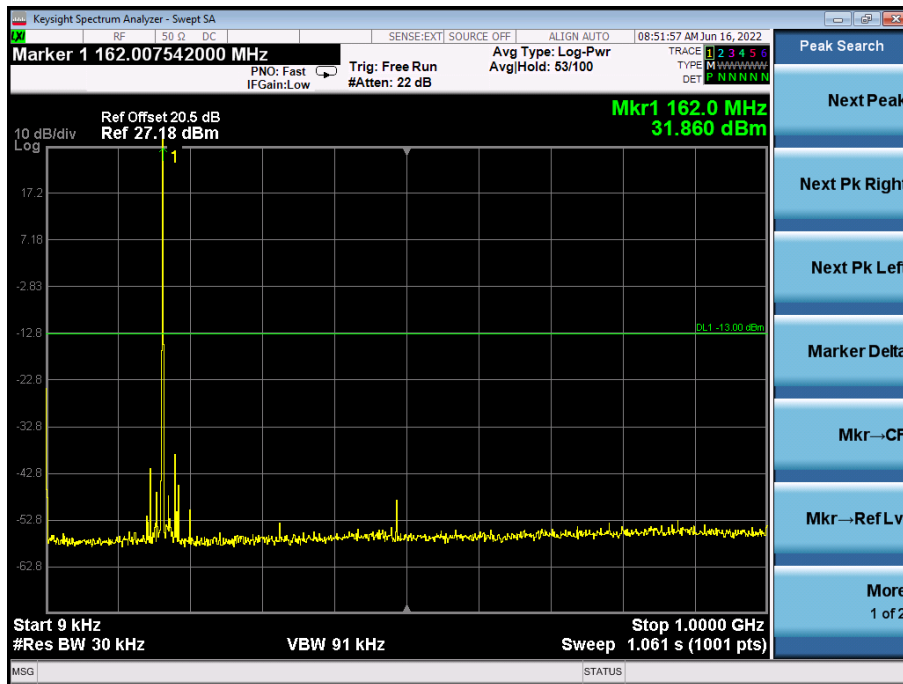

Figure 7 – 162.025 MHz - 9 kHz to 1 GHz

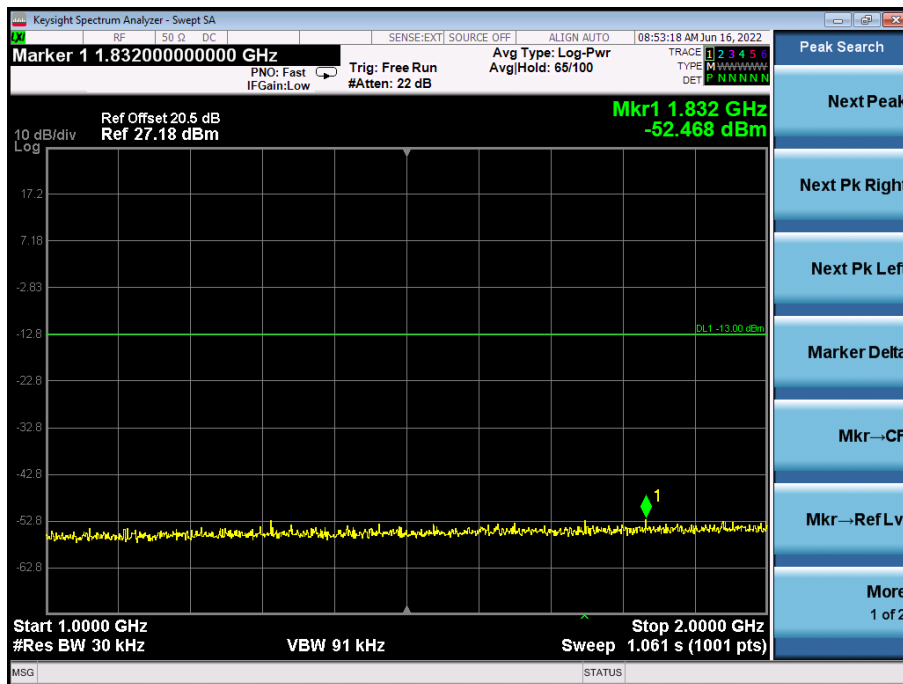

Figure 8 – 162.025 MHz - 1 GHz to 2 GHz



FCC 47 CFR Part 80, Limit Clause 80.211

Within 250% of the Authorised Bandwidth:

On any frequency removed from the assigned frequency by more than 50 percent up to and including 100 percent of the authorized bandwidth: At least 25 dB;

On any frequency removed from the assigned frequency by more than 100 percent up to and including 250 percent of the authorized bandwidth: At least 35 dB

More than 250% of the Authorised Bandwidth:

On any frequency removed from the assigned frequency by more than 250 percent of the authorized bandwidth: At least 43 plus $10\log_{10}$ (mean power in watts) dB.

ISED RSS-182, Limit Clause 7.9.1

On any frequency removed from the carrier frequency by more than 50%, but not more than 100% of the authorized bandwidth: at least 25 dB, measured with a bandwidth of 300 Hz.

On any frequency removed from the carrier frequency by more than 100%, but not more than 250% of the authorized bandwidth: at least 35 dB, measured with a bandwidth of 300 Hz.

On any frequency removed from the carrier frequency by more than 250% of the authorized bandwidth: at least $43 + 10 \log_{10} p(\text{watts})$ dB, measured with a bandwidth of 30 kHz

2.3.7 Test Location and Test Equipment Used

This test was carried out in RF Laboratory 3.

| Instrument | Manufacturer | Type No. | TE No. | Calibration Period (months) | Calibration Expiry Date |
|------------------------|-----------------------|---------------------------|--------|-----------------------------|-------------------------|
| Attenuator (20dB, 10W) | Weinschel | 37-20-34 | 482 | 12 | 17-Jan-2023 |
| Hygrometer | Rotronic | I-1000 | 2891 | 12 | 04-Nov-2022 |
| Network Analyser | Rohde & Schwarz | ZVA 40 | 3548 | 12 | 24-Feb-2023 |
| Calibration Unit | Rohde & Schwarz | ZV-Z54 | 4368 | 12 | 24-Feb-2023 |
| Frequency Standard | Spectracom | SecureSync 1200-0408-0601 | 4393 | 6 | 30-Jun-2022 |
| PXA Signal Analyser | Keysight Technologies | N9030A | 4653 | 12 | 08-Mar-2023 |
| Cable (18 GHz) | Rosenberger | LU7-036-2000 | 5037 | - | O/P Mon |

Table 11

O/P Mon – Output Monitored using calibrated equipment



2.4 Radiated Spurious Emissions

2.4.1 Specification Reference

FCC 47 CFR Part 2, Clause 2.1051
FCC 47 CFR Part 80, Clause 80.211
ISED RSS-182, Clause 5.9
ISED RSS-GEN, Clause 6.13.

2.4.2 Equipment Under Test and Modification State

RLB-44, S/N: TA000007 - Modification State 4

2.4.3 Date of Test

18-July-2022

2.4.4 Test Method

AIS

A preliminary profile of the Radiated Spurious Emissions was obtained up to the 10th harmonic by operating the EUT on a remotely controlled turntable within a semi-anechoic chamber. Measurements of emissions from the EUT were obtained with the Measurement Antenna in both Horizontal and Vertical Polarisations. The profiling produced a list of the worst-case emissions together with the EUT azimuth and antenna polarisation.

Testing was performed in accordance with ANSI C63.26, Clause 5.5.

Prescans and final measurements were performed using the direct field strength method.

Field strength measurements were performed and then converted to Equivalent Power Measurements in accordance with ANSI C63.26, Clause 5.2.7 equation c)

Example calculation:

$E \text{ (dBuV/m)} + 20\log(d) - 104.8 = \text{EIRP (dBm)}$ where (d) is the measurement distance.
 $82.2 \text{ (dBuV/m)} + 20\log(3) - 104.8 = \text{EIRP (dBm)}$
 $-13.0 = \text{EIRP (dBm)}$

2.4.5 Environmental Conditions

| | |
|---------------------|----------------|
| Ambient Temperature | 19.3 - 19.7 °C |
| Relative Humidity | 54.5 - 57.7 % |



2.4.6 Test Results

AIS

| Frequency (MHz) | Level (dBm) | Limit (dBm) | Margin (dB) | Detector | Angle (°) | Height (cm) | Polarisation |
|-----------------|-------------|-------------|-------------|----------|-----------|-------------|--------------|
| 323.969 | -34.2 | -13.0 | -21.2 | RMS | 360 | 100 | Vertical |

Table 12 – 161.975 MHz, 30 MHz to 2 GHz, X Orientation

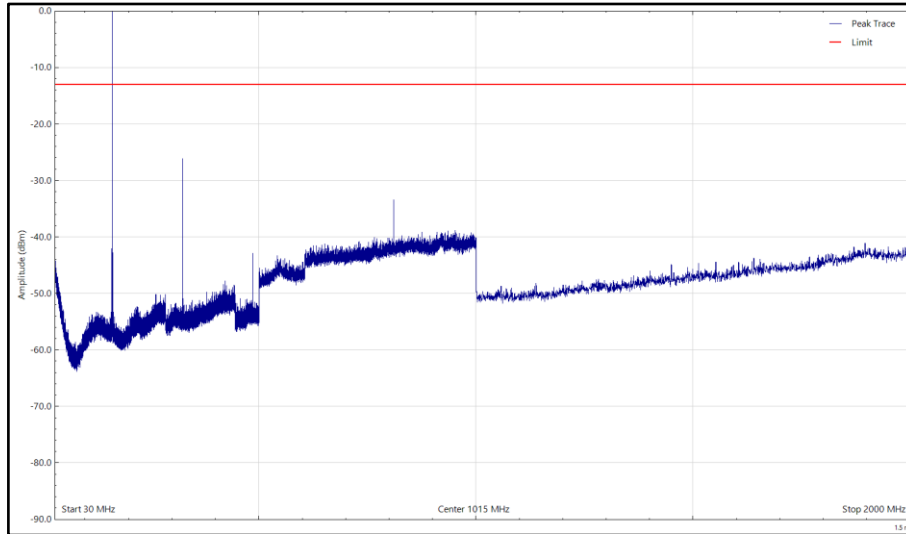

Figure 9 – 161.975 MHz, 30 MHz to 2 GHz, Horizontal, X Orientation

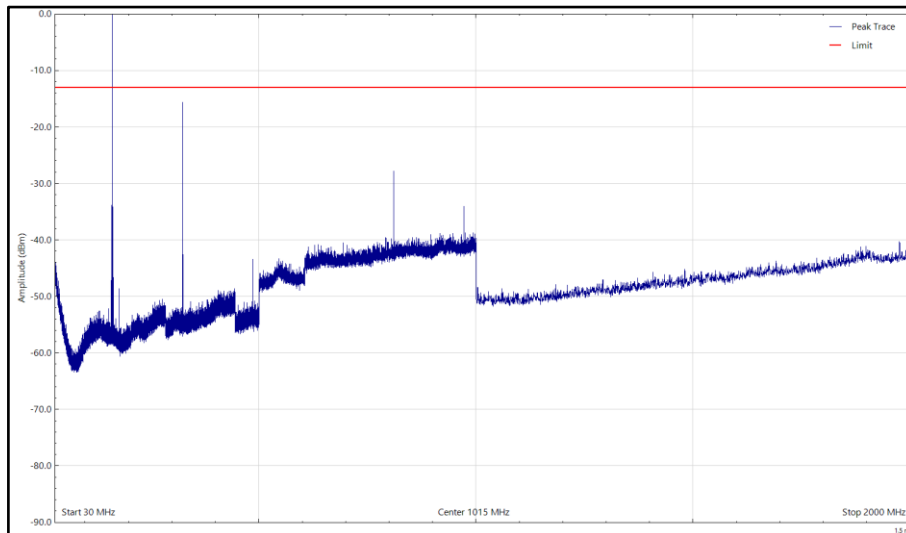

Figure 10 – 161.975 MHz, 30 MHz to 2 GHz, Vertical, X Orientation



| Frequency (MHz) | Level (dBm) | Limit (dBm) | Margin (dB) | Detector | Angle (°) | Height (cm) | Polarisation |
|-----------------|-------------|-------------|-------------|----------|-----------|-------------|--------------|
| 323.972 | -18.1 | -13.0 | -5.1 | RMS | 130 | 110 | Horizontal |

Table 13 – 161.975 MHz, 30 MHz to 2 GHz, Y Orientation

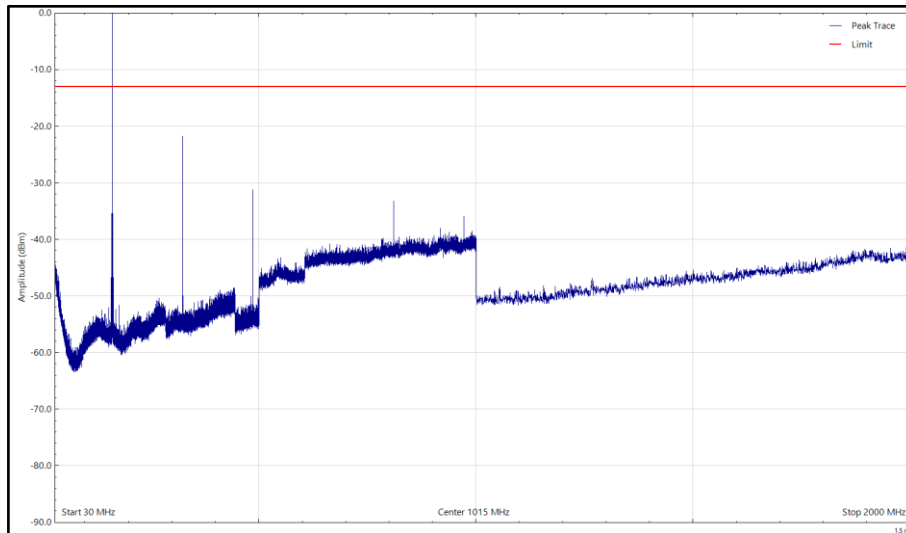

Figure 11 – 161.975 MHz, 30 MHz to 2 GHz, Horizontal, Y Orientation

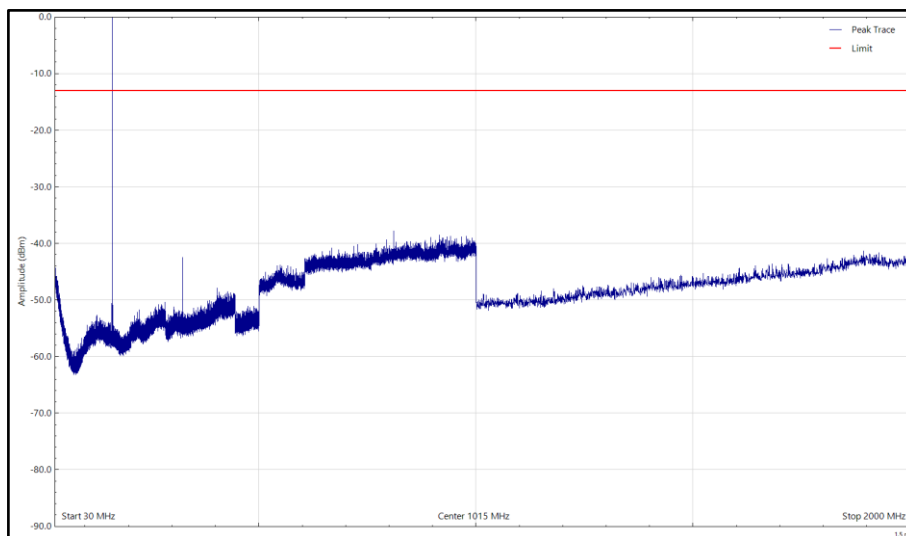

Figure 12 – 161.975 MHz, 30 MHz to 2 GHz, Vertical, Y Orientation



| Frequency (MHz) | Level (dBm) | Limit (dBm) | Margin (dB) | Detector | Angle (°) | Height (cm) | Polarisation |
|-----------------|-------------|-------------|-------------|----------|-----------|-------------|--------------|
| 323.950 | -19.9 | -13.0 | -6.9 | RMS | 321 | 100 | Vertical |

Table 14 – 161.975 MHz, 30 MHz to 2 GHz, Z Orientation

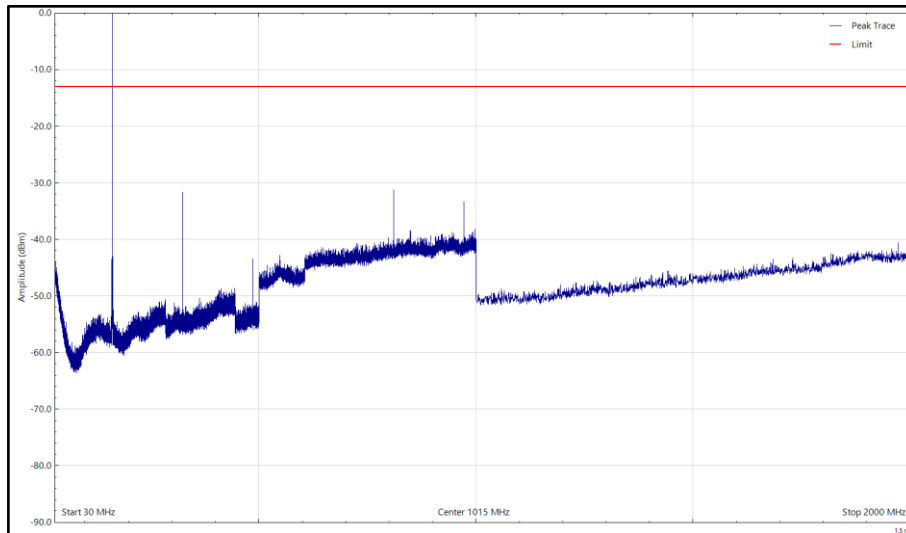

Figure 13 – 161.975 MHz, 30 MHz to 2 GHz, Horizontal, Z Orientation

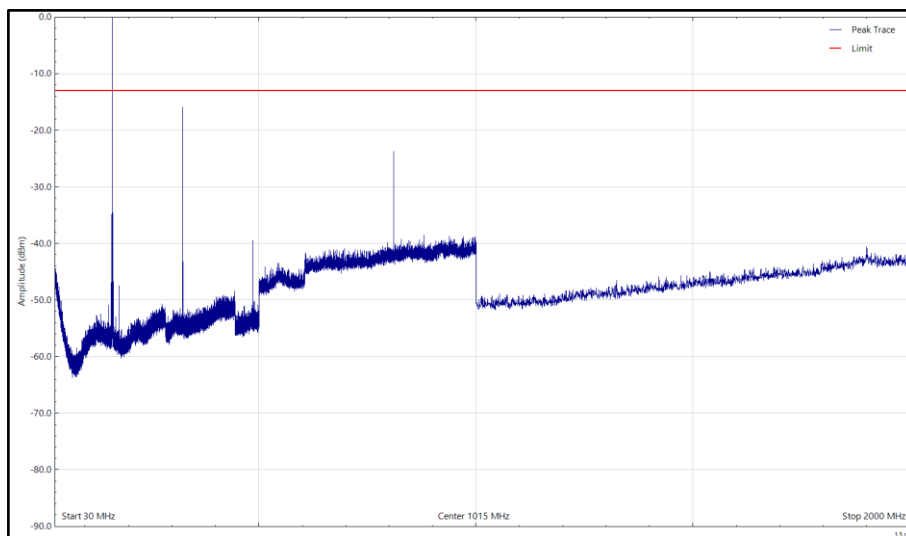

Figure 14 – 161.975 MHz, 30 MHz to 2 GHz, Vertical, Z Orientation



| Frequency (MHz) | Level (dBm) | Limit (dBm) | Margin (dB) | Detector | Angle (°) | Height (cm) | Polarisation |
|-----------------|-------------|-------------|-------------|----------|-----------|-------------|--------------|
| 324.047 | -19.2 | -13.0 | -6.2 | RMS | 266 | 100 | Vertical |

Table 15 – 162.025 MHz, 30 MHz to 2 GHz, X Orientation

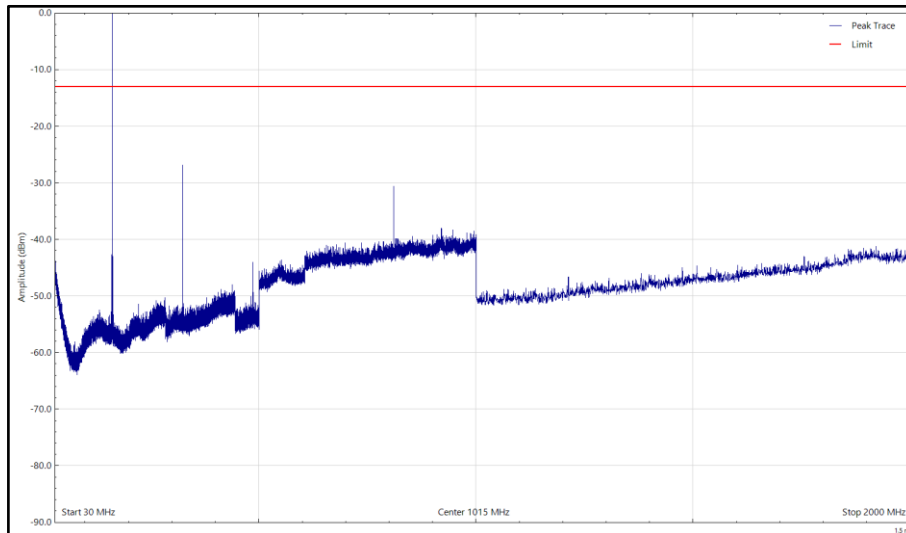

Figure 15 – 162.025 MHz, 30 MHz to 2 GHz, Horizontal, X Orientation

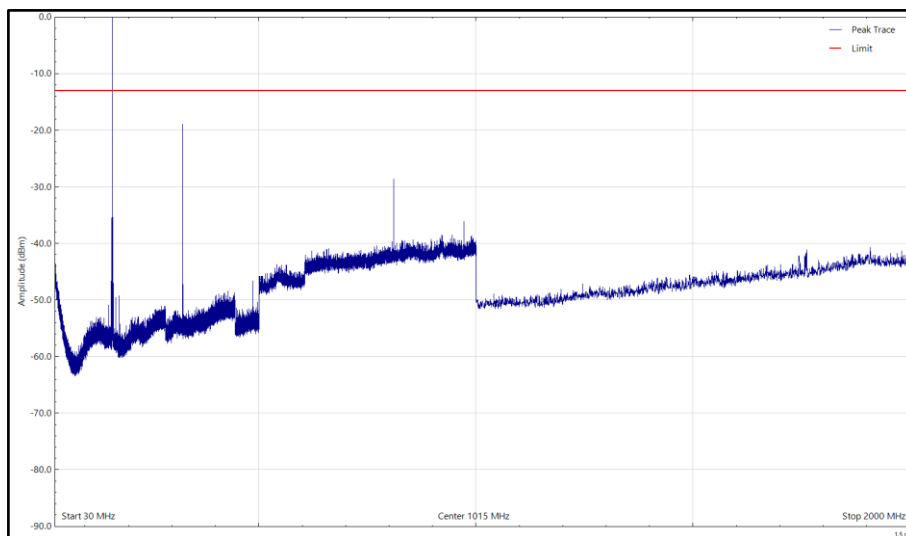

Figure 16 – 162.025 MHz, 30 MHz to 2 GHz, Vertical, X Orientation



| Frequency (MHz) | Level (dBm) | Limit (dBm) | Margin (dB) | Detector | Angle (°) | Height (cm) | Polarisation |
|-----------------|-------------|-------------|-------------|----------|-----------|-------------|--------------|
| 323.919 | -17.8 | -13.0 | -4.8 | RMS | 8 | 197 | Horizontal |

Table 16 – 162.025 MHz, 30 MHz to 2 GHz, Y Orientation

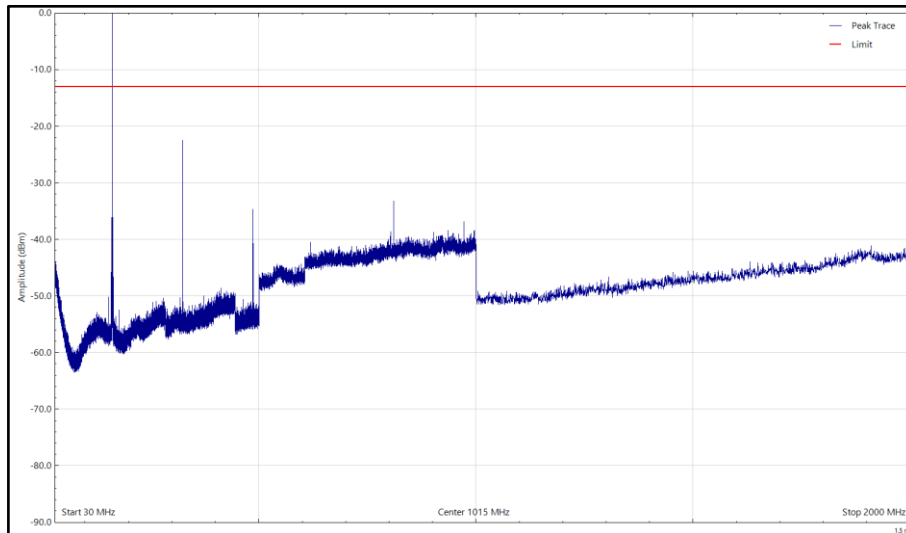

Figure 17 – 162.025 MHz, 30 MHz to 2 GHz, Horizontal, Y Orientation

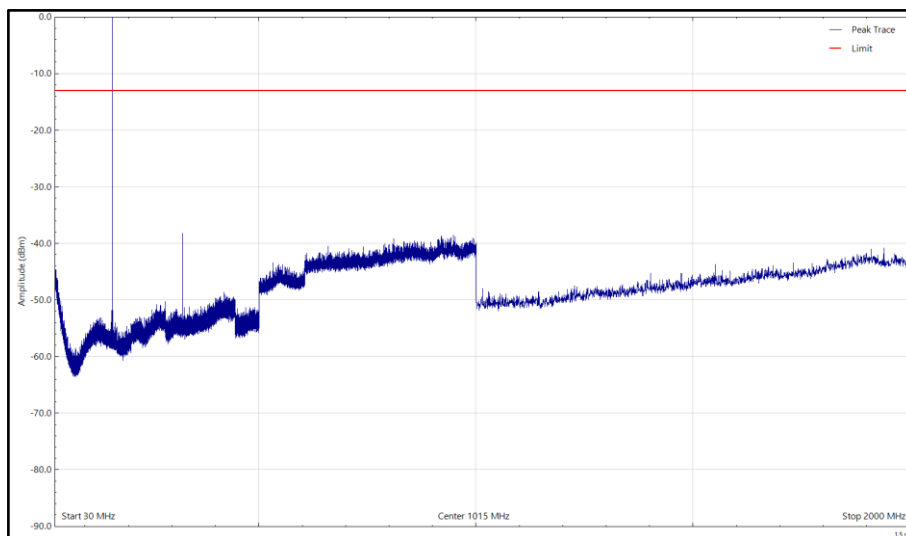

Figure 18 – 162.025 MHz, 30 MHz to 2 GHz, Vertical, Y Orientation



| Frequency (MHz) | Level (dBm) | Limit (dBm) | Margin (dB) | Detector | Angle (°) | Height (cm) | Polarisation |
|-----------------|-------------|-------------|-------------|----------|-----------|-------------|--------------|
| 324.051 | -13.5 | -13.0 | -0.4 | RMS | 352 | 100 | Vertical |

Table 17 – 162.025 MHz, 30 MHz to 2 GHz, Z Orientation

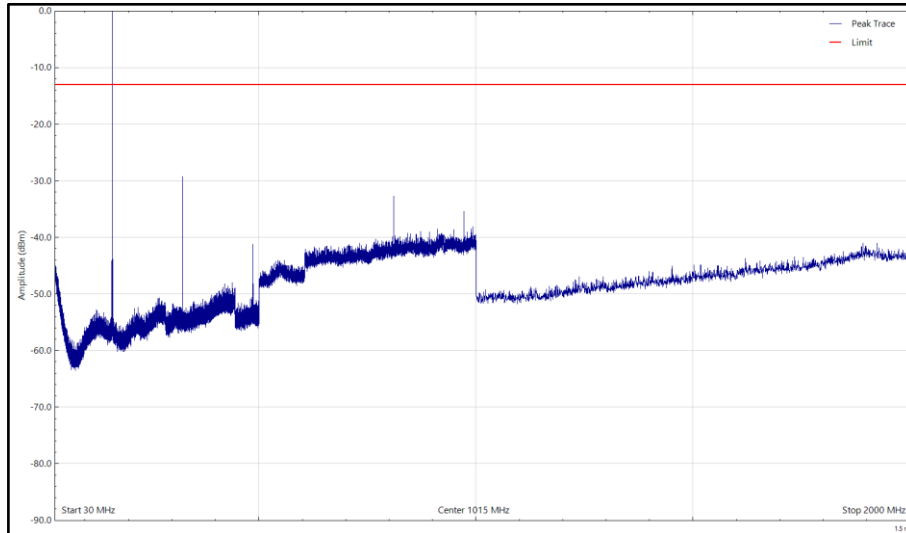

Figure 19 – 162.025 MHz, 30 MHz to 2 GHz, Horizontal, Z Orientation

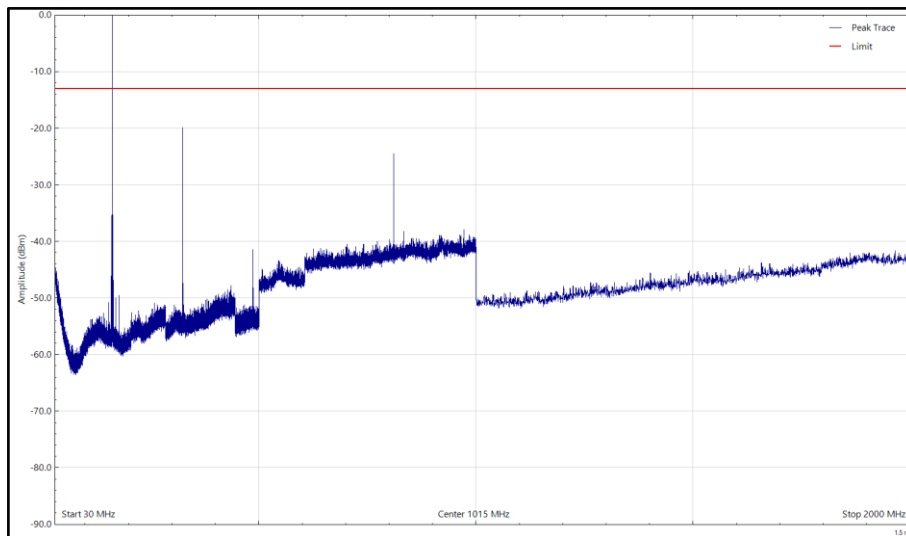

Figure 20 – 162.025 MHz, 30 MHz to 2 GHz, Vertical, Z Orientation

FCC 47 CFR Part 80, Limit Clause 80.211

More than 250% of the Authorised Bandwidth:

On any frequency removed from the assigned frequency by more than 250 percent of the authorized bandwidth: At least 43 plus $10\log_{10}$ (mean power in watts) dB.

ISED RSS-182, Limit Clause 7.9.1

On any frequency removed from the carrier frequency by more than 250% of the authorized bandwidth: at least $43 + 10 \log_{10}$ p(watts) dB, measured with a bandwidth of 30 kHz.



2.4.7 Test Location and Test Equipment Used

This test was carried out in EMC Chamber 12.

| Instrument | Manufacturer | Type No | TE No | Calibration Period (months) | Calibration Expires |
|--|-----------------|---------------------|-------|-----------------------------|---------------------|
| Antenna with attenuator (Bilog, 30 MHz to 3 GHz) | Schaffner | CBL6143 | 287 | 24 | 14-Oct-2022 |
| Test Receiver | Rohde & Schwarz | ESU40 | 3506 | 12 | 25-Mar-2023 |
| Cable (SMA to SMA, 2 m) | Rhophase | 3PS-1801A-2000-3PS | 4113 | 12 | 27-Jan-2023 |
| Emissions Software | TUV SUD | EmX V3.1.0 | 5125 | - | Software |
| Cable (N-Type to N-Type, 8 m) | Teledyne | PR90-088-8MTR | 5450 | 6 | 06-Oct-2022 |
| Thermo-Hygro-Barometer | PCE Instruments | PCE-THB-40 | 5481 | 12 | 06-Apr-2023 |
| Turntable & Mast Controller | Maturo Gmbh | NCD/498/2799.01 | 5612 | - | TU |
| Tilt Antenna Mast | Maturo Gmbh | TAM 4.0-P | 5613 | - | TU |
| Turntable | Maturo Gmbh | Turntable 1.5 SI-2t | 5614 | - | TU |
| Screened Room (12) | MVG | EMC-3 | 5621 | 36 | 11-Aug-2023 |

Table 18

TU – Traceability Unscheduled



2.5 Modulation Requirements

2.5.1 Specification Reference

FCC 47 CFR Part 2, Clause 2.1047
FCC 47 CFR Part 80, Clause 80.213
ISED RSS-182, Clause 5.4

2.5.2 Equipment Under Test and Modification State

RLB-44, S/N: TA000022 - Modification State 2

2.5.3 Date of Test

16-June-2022

2.5.4 Test Method

AIS

The test was applied in accordance with the test method requirements of FCC CFR 47 Part 80.213 (d).

The EUT was transmitting at maximum power, modulated by the standard AIS test signals using either PRBS, 01010101 or 00001111 packet payloads. The EUT was connected to a spectrum analyser via a cable and attenuator, using the FM demodulation function of the spectrum analyser, the peak frequency deviation was observed and shown in the plots on the following pages.

2.5.5 Environmental Conditions

| | |
|---------------------|---------|
| Ambient Temperature | 24.2 °C |
| Relative Humidity | 38.5 % |



2.5.6 Test Results

AIS

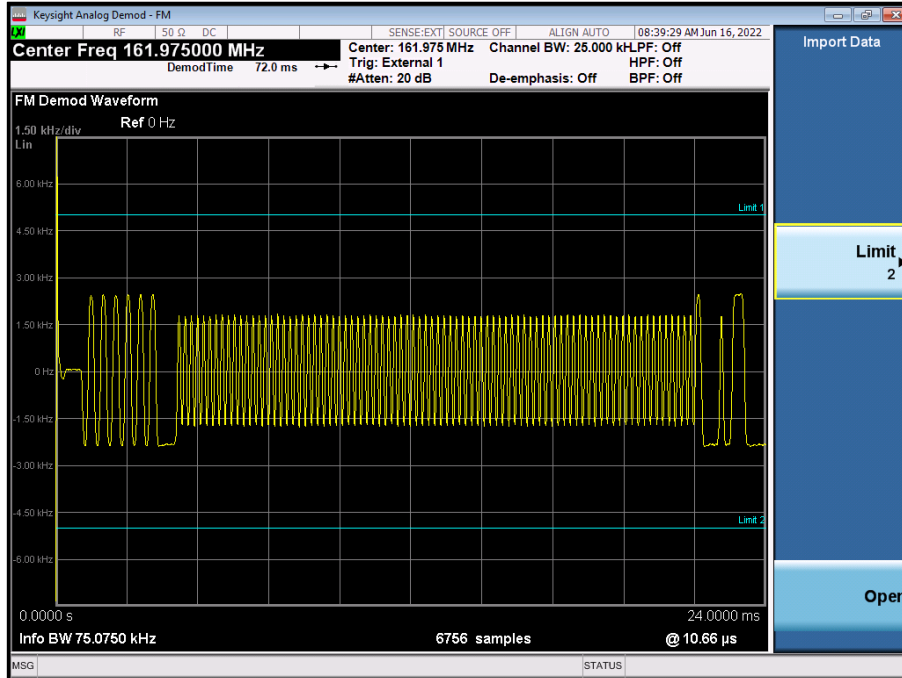

Figure 21 - 161.975 MHz - 01010101

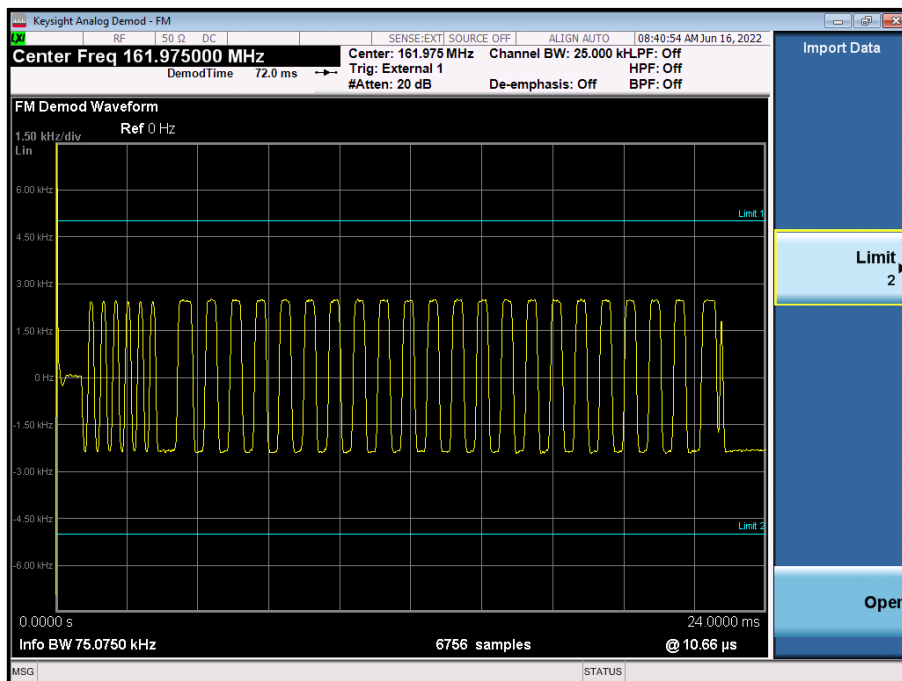

Figure 22- 161.975 MHz - 00001111

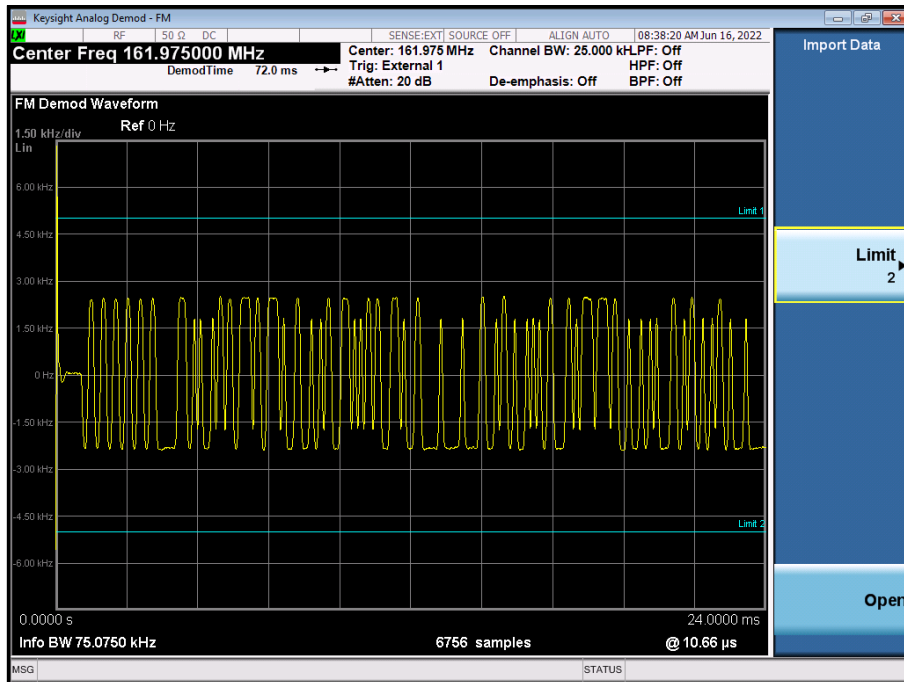

Figure 23- 161.975 MHz - PRBS

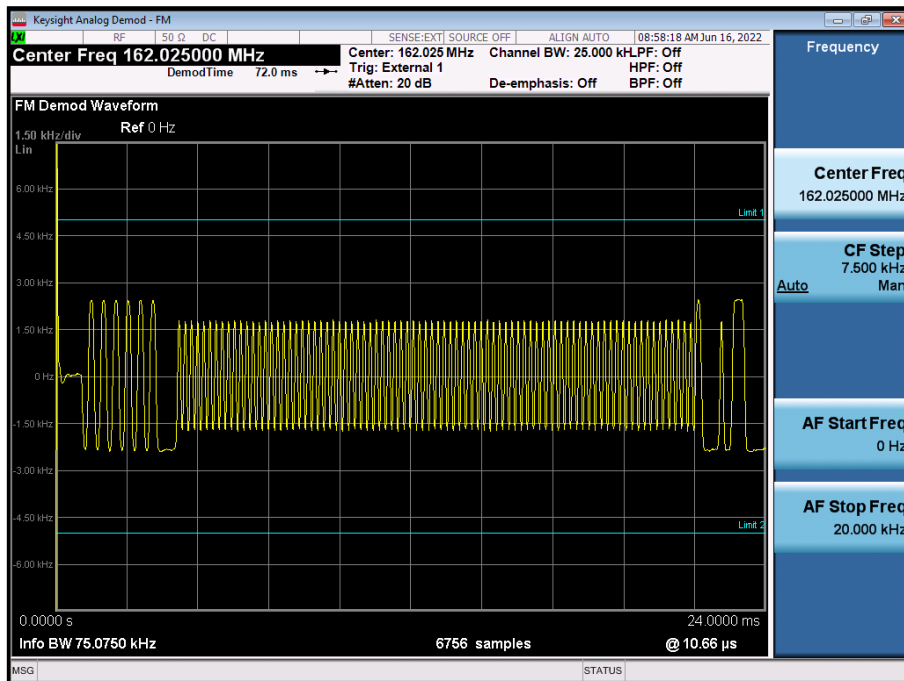

Figure 24 - 162.025 MHz - 01010101

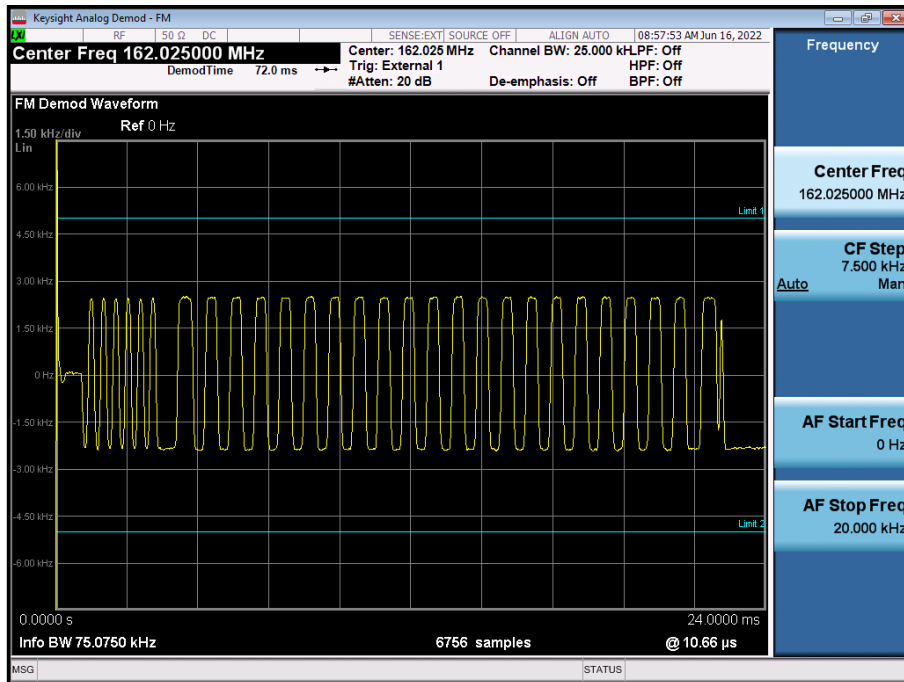

Figure 25- 162.025 MHz - 00001111

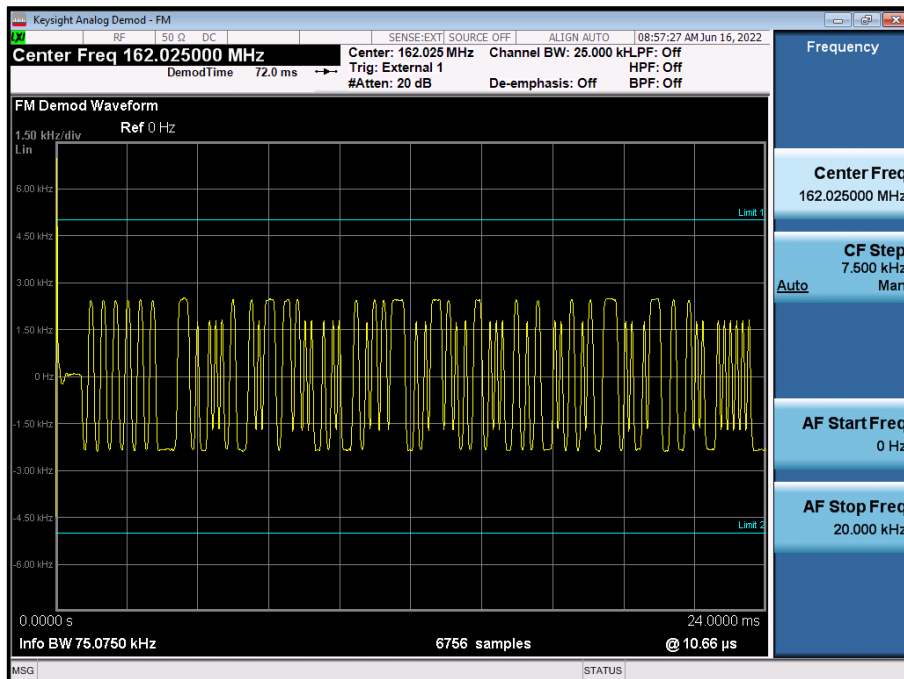

Figure 26- 162.025 MHz - PRBS



FCC 47 CFR Part 80, Limit Clause 80.213(d)

Ship and coast station transmitters operating in the 156–162 MHz and 216–220 bands must be capable of proper operation with a frequency deviation that does not exceed ± 5 kHz when using any emission authorized by § 80.207

ISED RSS-182, Limit Clause 5.7

The VHF AIS equipment shall comply with the following characteristics.

Transmitter frequency: 161.975 MHz (channel AIS1)
 162.025 MHz (channel AIS2)
 Channel spacing: 25 kHz or 12.5 kHz
 Modulation scheme: GMSK/FM
 Modulation index: 0.5 max. for 25 kHz channel spacing
 0.25 max. for 12.5 kHz channel spacing
 Transmission rate: 9600 bps

2.5.7 Test Location and Test Equipment Used

This test was carried out in RF Laboratory 3.

| Instrument | Manufacturer | Type No. | TE No. | Calibration Period (months) | Calibration Expiry Date |
|------------------------|-----------------------|---------------------------|--------|-----------------------------|-------------------------|
| Attenuator (20dB, 10W) | Weinschel | 37-20-34 | 482 | 12 | 17-Jan-2023 |
| Hygrometer | Rotronic | I-1000 | 2891 | 12 | 04-Nov-2022 |
| Frequency Standard | Spectracom | SecureSync 1200-0408-0601 | 4393 | 6 | 30-Jun-2022 |
| PXA Signal Analyser | Keysight Technologies | N9030A | 4653 | 12 | 08-Mar-2023 |
| Cable (18 GHz) | Rosenberger | LU7-036-2000 | 5037 | - | O/P Mon |

Table 19

O/P Mon – Output Monitored using calibrated equipment



2.6 Bandwidths

2.6.1 Specification Reference

FCC 47 CFR Part 2, Clause 2.1049
FCC 47 CFR Part 80, Clause 80.205
ISED RSS-GEN, Clause 6.7

2.6.2 Equipment Under Test and Modification State

RLB-44, S/N: TA000022 - Modification State 2

2.6.3 Date of Test

15-June-2022

2.6.4 Test Method

121.5 MHz Homing Transmitter

The test was applied in accordance with the test method requirements of FCC CFR 47 Part 80.205 and Part 2.1049.

The EUT was transmitting at maximum power, with normal modulation as described in FCC CFR 47 Part 2.1049. The EUT was connected to a spectrum analyser via a cable and attenuator, the RBW of the spectrum analyser was set to at least 1% of the emission bandwidth, the occupied bandwidth measurement function of the analyser was used and the 99% bandwidth recorded.

The plots on the following pages show the resultant display from the Spectrum Analyser.

2.6.5 Environmental Conditions

| | |
|---------------------|---------|
| Ambient Temperature | 25.3 °C |
| Relative Humidity | 35.0 % |



2.6.6 Test Results

121.5 MHz Homing Transmitter

| |
|--------------------------|
| Occupied Bandwidth (kHz) |
| 16.641 |

Table 20 - Occupied Bandwidth Results - 121.5 MHz

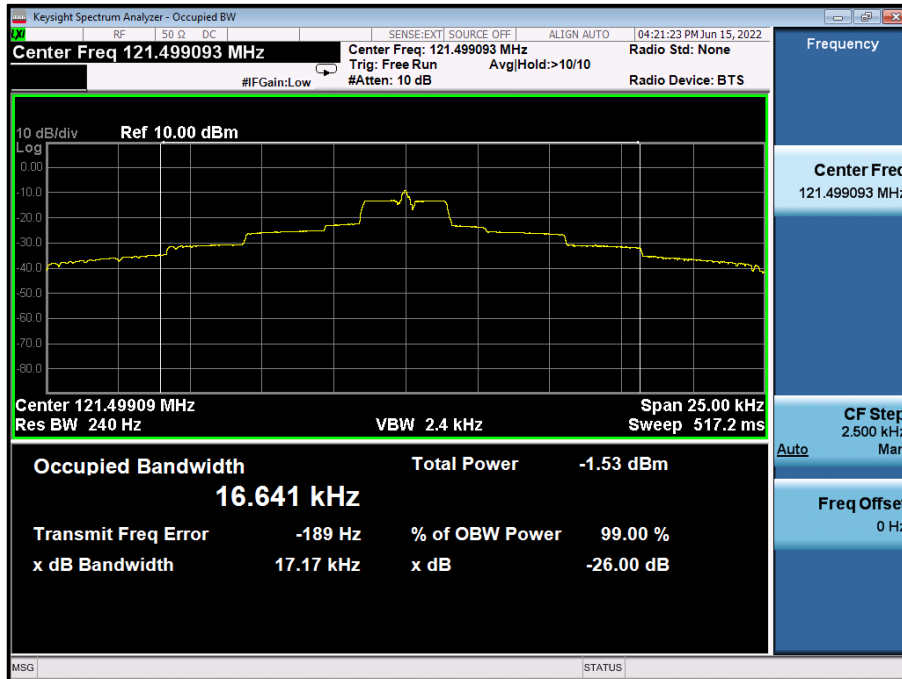

Figure 27 - Occupied Bandwidth

FCC 47 CFR Part 80, Limit Clause 80.205

< 25 kHz



2.6.7 Test Location and Test Equipment Used

This test was carried out in RF Laboratory 3.

| Instrument | Manufacturer | Type No. | TE No. | Calibration Period (months) | Calibration Expiry Date |
|------------------------|-----------------------|---------------------------|--------|-----------------------------|-------------------------|
| Attenuator (20dB, 10W) | Weinschel | 37-20-34 | 482 | 12 | 17-Jan-2023 |
| Hygrometer | Rotronic | I-1000 | 2891 | 12 | 04-Nov-2022 |
| Frequency Standard | Spectracom | SecureSync 1200-0408-0601 | 4393 | 6 | 30-Jun-2022 |
| PXA Signal Analyser | Keysight Technologies | N9030A | 4653 | 12 | 08-Mar-2023 |
| Cable (18 GHz) | Rosenberger | LU7-036-2000 | 5037 | - | O/P Mon |

Table 21

O/P Mon – Output Monitored using calibrated equipment



2.7 Transmitter Frequency Tolerances

2.7.1 Specification Reference

FCC 47 CFR Part 2, Clause 2.1055
FCC 47 CFR Part 80, Clause 80.209
ISED RSS-287, Clause 7.4.2
ISED RSS-GEN, Clause 6.11.

2.7.2 Equipment Under Test and Modification State

RLB-44, S/N: TA000022 - Modification State 2

2.7.3 Date of Test

17-June-2022 to 21-June-2022

2.7.4 Test Method

121.5 MHz Homing Transmitter

The test was applied in accordance with the test method requirements of FCC CFR 47 Part 80.209 (a).

The EUT was connected to a spectrum analyser via a cable and attenuator. The external frequency reference of the spectrum analyser was locked to a 10 MHz rubidium frequency standard reference. The spectrum analyser was used to record the carrier frequency error. The temperature was varied from -30°C to +55°C in 10° steps. At 20°C the voltage was also reduced to the manufacturers declared operating battery endpoint voltage.

2.7.5 Environmental Conditions

| | |
|---------------------|----------------|
| Ambient Temperature | 24.9 - 27.9 °C |
| Relative Humidity | 33.6 - 34.0 % |



2.7.6 Test Results

121.5 MHz Homing Transmitter

| Voltage | Frequency Error (ppm) |
|----------------------|-----------------------|
| 5.5 V DC (End-Point) | -7.25 |
| 9.0 V DC (Nominal) | -5.73 |

Table 22 - Frequency Stability Under Voltage Variations

| Temperature | Frequency Error (ppm) |
|-------------|-----------------------|
| +55.0 °C | -14.32 |
| +50.0 °C | -13.88 |
| +40.0 °C | -11.62 |
| +30.0 °C | -8.55 |
| +10.0 °C | -2.72 |
| 0 °C | -1.18 |
| -10.0 °C | -1.33 |
| -20.0 °C | -2.88 |
| -30.0 °C | -8.31 |

Table 23 - Frequency Stability Under Temperature Variations

FCC 47 CFR Part 80, Limit Clause 80.209

± 50 ppm.

ISED RSS-287, Limit Clause 7.4.2

The carrier frequency shall not depart by more than 0.005% (±50 ppm) from that measured at 20 °C and the rated supply voltage. If the 121.5 MHz and 243 MHz frequencies are derived from the same oscillator circuitry, it is not necessary to repeat the frequency stability test for the other frequency.



2.7.7 Test Location and Test Equipment Used

This test was carried out in RF Laboratory 3.

| Instrument | Manufacturer | Type No. | TE No. | Calibration Period (months) | Calibration Expiry Date |
|--------------------------|-----------------------|---------------------------|--------|-----------------------------|-------------------------|
| Attenuator (20dB, 10W) | Weinschel | 37-20-34 | 482 | 12 | 17-Jan-2023 |
| Hygrometer | Rotronic | I-1000 | 2891 | 12 | 04-Nov-2022 |
| Thermocouple Data Logger | Pico Technology Ltd | TC-08 | 3783 | 12 | 24-Jun-2022 |
| Frequency Standard | Spectracom | SecureSync 1200-0408-0601 | 4393 | 6 | 30-Jun-2022 |
| PXA Signal Analyser | Keysight Technologies | N9030A | 4653 | 12 | 08-Mar-2023 |
| Cable (18 GHz) | Rosenberger | LU7-036-2000 | 5037 | - | O/P Mon |
| Environmental Chamber | ACS | DY110TC | 5589 | - | O/P Mon |
| Signal Analyzer | Keysight Technologies | N9020B-ATO-43105 | 5742 | 12 | 03-Feb-2023 |

Table 24

O/P Mon – Output Monitored using calibrated equipment



2.8 Spurious Emissions at Antenna Terminals

2.8.1 Specification Reference

FCC 47 CFR Part 2, Clause 2.1051
FCC 47 CFR Part 80, Clause 80.211
ISED RSS-287, Clause 7.4.4
ISED RSS-GEN, Clause,6.13.

2.8.2 Equipment Under Test and Modification State

RLB-44, S/N: TA000022 - Modification State 2

2.8.3 Date of Test

15-June-2022 to 17-June-2022 & 25-July-2022

2.8.4 Test Method

121.5 MHz Homing Transmitter

For emissions where the frequency is removed less than 250% of the authorized bandwidth measurements were performed as follows:

The EUT was connected to a spectrum analyser via a cable and attenuator. The path loss between the EUT and analyser was calibrated using a network analyser and entered into the spectrum analyser as a reference level offset. The RBW was configured to 300 Hz using an average detector with max hold.

For emissions where the frequency is removed more than 250% of the authorized bandwidth measurements were performed as follows:

A network analyser was used to measure the path loss and the worst case was entered as a reference level offset into the spectrum analyser. The EUT was connected to a spectrum analyser via an attenuator and cable. The analyser was configured with an RBW of 100 kHz below 1 GHz and was set to 1 MHz for above 1 GHz with the trace set to max hold using a peak detector.

2.8.5 Environmental Conditions

| | |
|---------------------|----------------|
| Ambient Temperature | 25.3 - 27.9 °C |
| Relative Humidity | 33.6 - 35.0 % |



2.8.6 Test Results

121.5 MHz Homing Transmitter

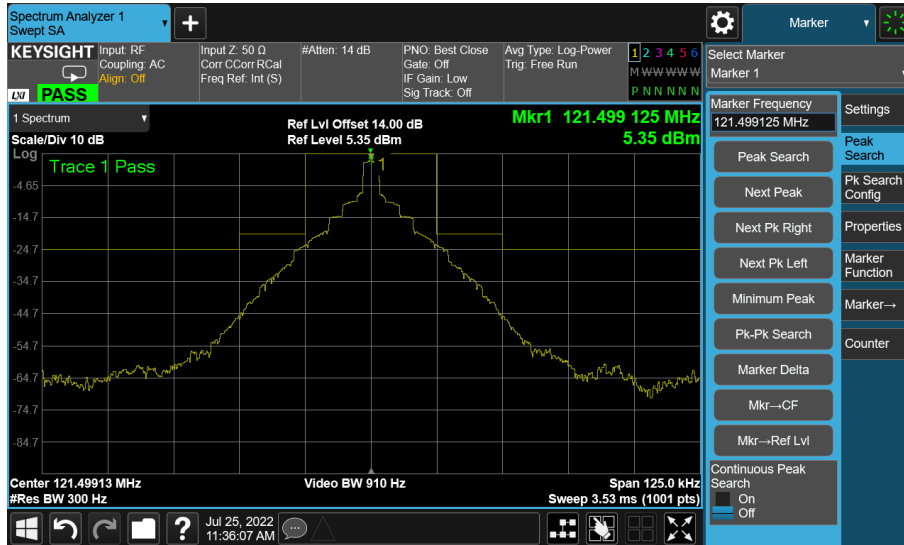

Figure 28 - Transmitter Spectrum Mask

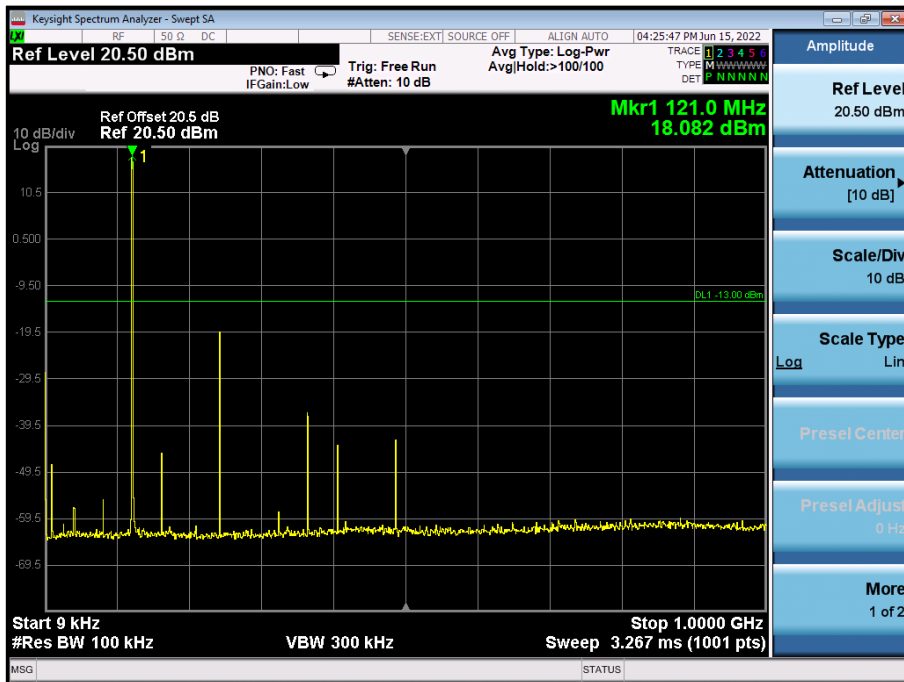

Figure 29 - 9 kHz to 1 GHz

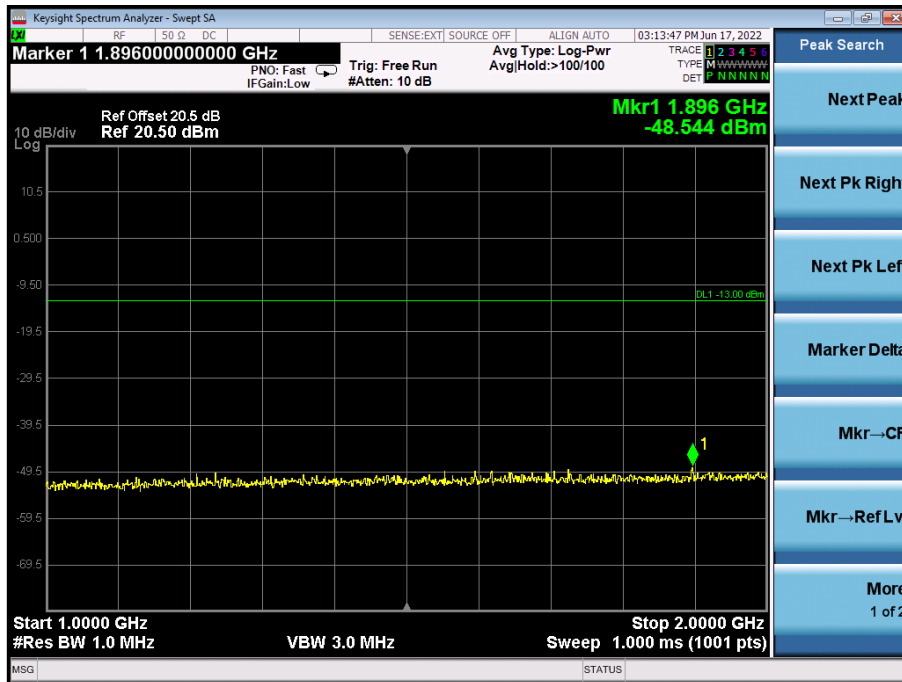

Figure 30 - 1 GHz to 2 GHz



FCC 47 CFR Part 80, Limit Clause 80.211

Within 250% of the Authorised Bandwidth:

On any frequency removed from the assigned frequency by more than 50 percent up to and including 100 percent of the authorized bandwidth: At least 25 dB;

On any frequency removed from the assigned frequency by more than 100 percent up to and including 250 percent of the authorized bandwidth: At least 35 dB

More than 250% of the Authorised Bandwidth:

On any frequency removed from the assigned frequency by more than 250 percent of the authorized bandwidth: At least 43 plus $10\log_{10}$ (mean power in watts) dB.

ISED RSS-287, Limit Clause 7.4.4

The average power of unwanted emissions in a 300 Hz resolution bandwidth shall be attenuated below the level of the average transmitter power P (dBW) by:

- (a) at least 25 dB on any frequency removed from the centre of the authorized bandwidth by more than 50%, up to and including 100% of the authorized bandwidth; and
- (b) at least 30 dB on any frequency removed from the centre of the authorized bandwidth by more than 100%

where the authorized bandwidth is set at 25 kHz with the transmit frequency at the centre of the bandwidth.

2.8.7 Test Location and Test Equipment Used

This test was carried out in RF Laboratory 3.

| Instrument | Manufacturer | Type No. | TE No. | Calibration Period (months) | Calibration Expiry Date |
|------------------------|-----------------------|---------------------------|--------|-----------------------------|-------------------------|
| Attenuator (20dB, 10W) | Weinschel | 37-20-34 | 482 | 12 | 17-Jan-2023 |
| Hygrometer | Rotronic | I-1000 | 2891 | 12 | 04-Nov-2022 |
| Network Analyser | Rohde & Schwarz | ZVA 40 | 3548 | 12 | 24-Feb-2023 |
| Calibration Unit | Rohde & Schwarz | ZV-Z54 | 4368 | 12 | 24-Feb-2023 |
| Frequency Standard | Spectracom | SecureSync 1200-0408-0601 | 4393 | 6 | 30-Jun-2022 |
| PXA Signal Analyser | Keysight Technologies | N9030A | 4653 | 12 | 08-Mar-2023 |
| Cable (18 GHz) | Rosenberger | LU7-036-2000 | 5037 | - | O/P Mon |

Table 25

O/P Mon – Output Monitored using calibrated equipment



2.9 Radiated Spurious Emissions

2.9.1 Specification Reference

FCC 47 CFR Part 2, Clause 2.1053
FCC 47 CFR Part 80, Clause 80.211
ISED RSS-287, Clause 7.9
ISED RSS-GEN, Clause,6.13.

2.9.2 Equipment Under Test and Modification State

RLB-44, S/N: TA000007 - Modification State 2
RLB-44, S/N: TA000007 - Modification State 4

2.9.3 Date of Test

21-June-2021 and 18-July-2022*

*NOTE: The testing was performed on two dates. The 30 MHz – 1 GHz was performed on the 21-June-2022 and the 1 GHz – 2 GHz was performed on the 18-July-2022. This was due to a finding during the AIS radiated emission measurements which the sample had to be returned to the customer for a modification. See Annex B for further details about the finding and how only the AIS was affected.

2.9.4 Test Method

This test was performed in accordance with ANSI C63.26, clause 5.5.

Measurements were made at a distance of 3m. Field strength limits were calculated using the following formula:

Limit (Field Strength) = Limit (EIRP) + 95.2 dB
82.2 dB μ V/m = -13 dBm + 95.2 dB

2.9.5 Environmental Conditions

Ambient Temperature 18.9 - 24.2 °C
Relative Humidity 36.8 - 55.9 %

2.9.6 Test Results

121.5 MHz Homing Transmitter

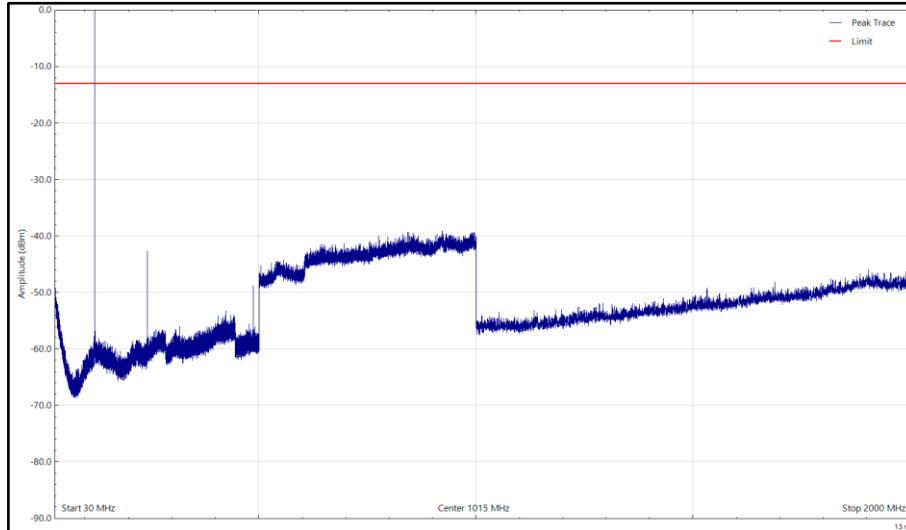

Figure 31 - 121.5MHz, 30 MHz to 2 GHz, Horizontal, X Orientation

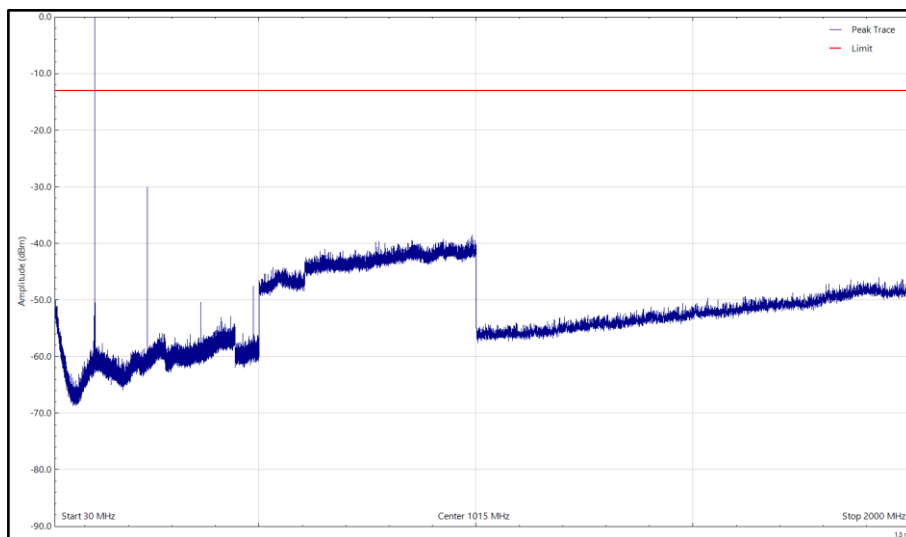

Figure 32 - 121.5MHz, 30 MHz to 2 GHz, Vertical, X Orientation

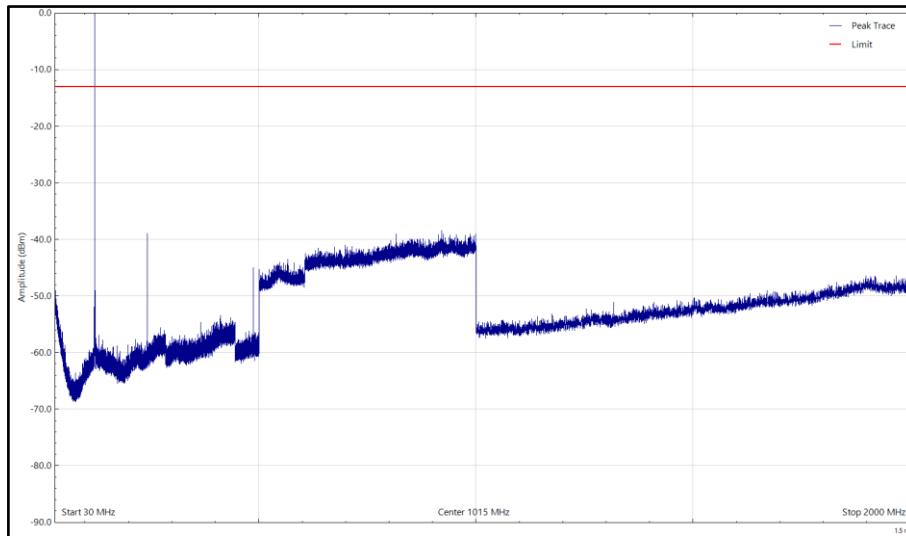

Figure 33 - 121.5MHz, 30 MHz to 2 GHz, Horizontal, Y Orientation

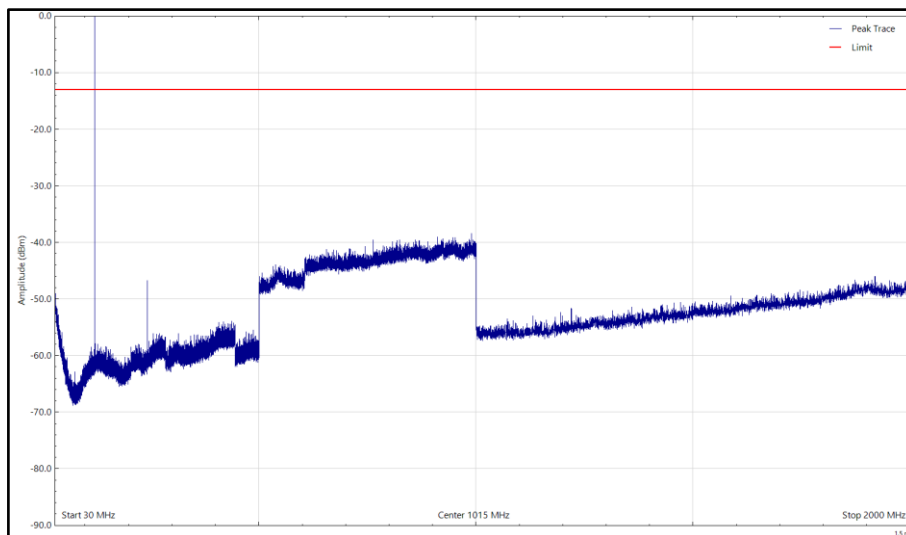

Figure 34 - 121.5MHz, 30 MHz to 2 GHz, Vertical, Y Orientation

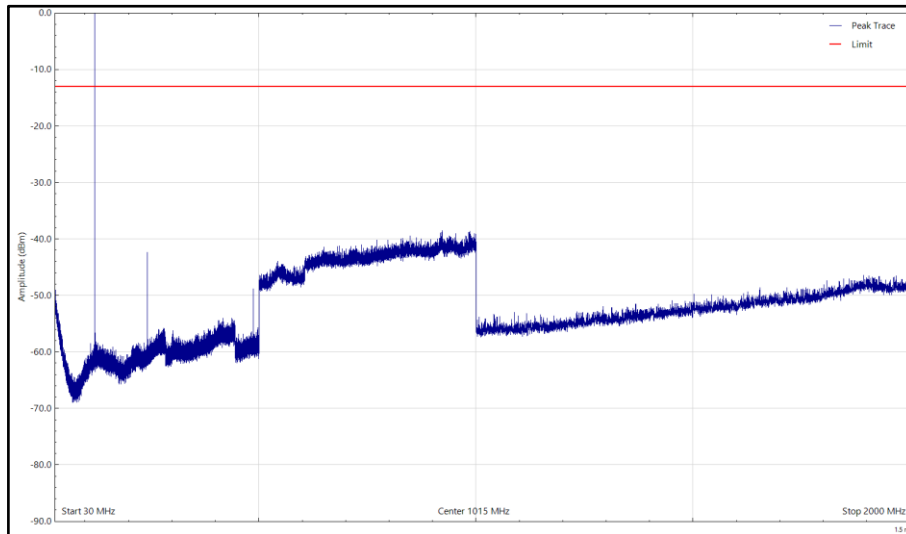

Figure 35 - 121.5MHz, 30 MHz to 2 GHz, Horizontal, Z Orientation

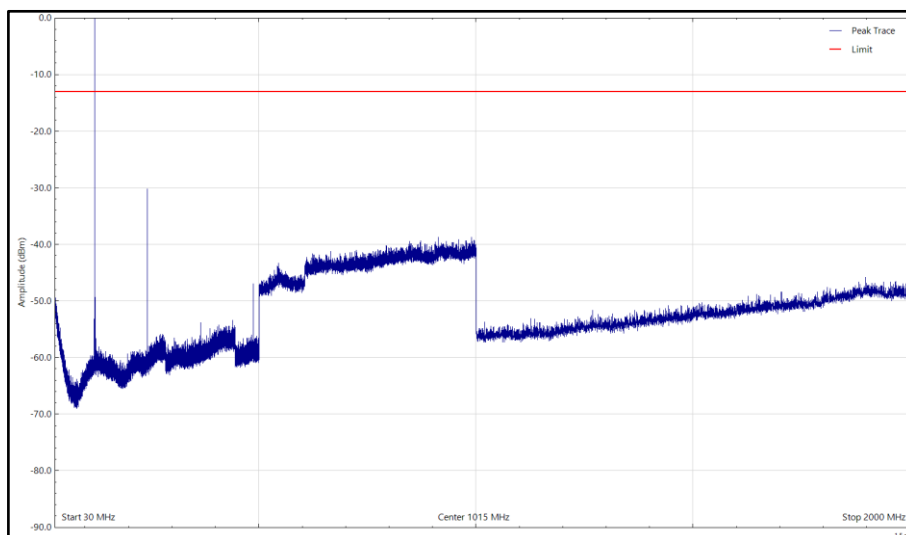

Figure 36 - 121.5MHz, 30 MHz to 2 GHz, Vertical, Z Orientation

FCC 47 CFR Part 80, Limit Clause 80.211

More than 250% of the Authorised Bandwidth:

On any frequency removed from the assigned frequency by more than 250 percent of the authorized bandwidth: At least 43 plus $10\log_{10}$ (mean power in watts) dB.



2.9.7 Test Location and Test Equipment Used

This test was carried out in EMC Chamber 12.

| Instrument | Manufacturer | Type No | TE No | Calibration Period (months) | Calibration Expires |
|--|-----------------|---------------------|-------|-----------------------------|---------------------|
| Antenna with attenuator (Bilog, 30 MHz to 3 GHz) | Schaffner | CBL6143 | 287 | 24 | 14-Oct-2022 |
| Test Receiver | Rohde & Schwarz | ESU40 | 3506 | 12 | 25-Mar-2023 |
| Cable (SMA to SMA, 2 m) | Rhophase | 3PS-1801A-2000-3PS | 4113 | 12 | 27-Jan-2023 |
| Emissions Software | TUV SUD | EmX V3.1.0 | 5125 | - | Software |
| Cable (N-Type to N-Type, 8 m) | Teledyne | PR90-088-8MTR | 5450 | 6 | 06-Oct-2022 |
| Thermo-Hygro-Barometer | PCE Instruments | PCE-THB-40 | 5481 | 12 | 06-Apr-2023 |
| Turntable & Mast Controller | Maturo Gmbh | NCD/498/2799.01 | 5612 | - | TU |
| Tilt Antenna Mast | Maturo Gmbh | TAM 4.0-P | 5613 | - | TU |
| Turntable | Maturo Gmbh | Turntable 1.5 SI-2t | 5614 | - | TU |
| Screened Room (12) | MVG | EMC-3 | 5621 | 36 | 11-Aug-2023 |

Table 26

TU – Traceability Unscheduled



2.10 Modulation Characteristics

2.10.1 Specification Reference

FCC 47 CFR Part 2, Clause 2.1047
FCC 47 CFR Part 80, Clause 80.213
ISED RSS-287, Clause 7.4.1

2.10.2 Equipment Under Test and Modification State

RLB-44, S/N: TA000022 - Modification State 2

2.10.3 Date of Test

15-June-2022 to 16-June-2022

2.10.4 Test Method

121.5 MHz Homing Transmitter

This test EUT antenna was connected either directly to the oscilloscope via a cable and attenuator or was connected to the spectrum analyser and then the demodulated output of the spectrum analyser was connected to the oscilloscope.

The markers on the oscilloscope were used to measure the parameters specified in the table below.

2.10.5 Environmental Conditions

| | |
|---------------------|----------------|
| Ambient Temperature | 24.2 - 25.3 °C |
| Relative Humidity | 35.0 - 38.5 % |



2.10.6 Test Results

121.5 MHz Homing Transmitter

| Requirement | Result | Unit |
|---|-----------|---------|
| Audio Sweep Frequency (low) | 437.9 | Hz |
| Audio Sweep Frequency (high) | 1325.5 | Hz |
| Audio Sweep Frequency Range | 887.6 | Hz |
| Audio Sweep Frequency Direction | Downwards | - |
| Audio Sweep Repetition Rate | 3.01 | Hz |
| Modulation Factor | 0.89 | - |
| The transmitter can be interrupted for up to two seconds during the transmission of the 406 MHz burst | 0.55 | Seconds |
| 30% Occupied Bandwidth | 7 | Hz |
| Modulation Duty Cycle (low) | 37.8 | % |
| Modulation Duty Cycle (mid) | 38.1 | % |
| Modulation Duty Cycle (high) | 39.2 | % |

Table 27 - Modulation Characteristics



FCC 47 CFR Part 80, Limit Clause 80.1061(b)

The 406.0-406.1 EPIRB must contain as an integral part a “homing” beacon operating only on 121.500 MHz that meets all the requirements described in the RTCM Recommended Standards document described in paragraph (a) of this section. The 121.500 MHz “homing” beacon must have a continuous duty cycle that may be interrupted during the transmission of the 406.0-406.1 MHz signal only.

ISED RSS-287, Limit Clause 7.4.1

| Requirement | Limit |
|--|-----------------------|
| The carrier is not interrupted (except for two seconds encompassing the transmission of the 406 MHz pulse plus the additional time required for the Morse “P” transmission). | True |
| Lower Audio Frequency | > 300 Hz |
| Upper Audio Frequency | < 1600 Hz |
| Audio Frequency Range | > 700 Hz |
| Sweep Repetition Rate | Between 2 Hz and 4 Hz |
| Modulation Duty Cycle | Between 33% and 55% |
| Modulation Factor | Between 85% and 100% |
| 30% of the total power emitted shall be contained within ± 30 Hz of the carrier frequency | < 60 Hz |
| Morse Letter P: | |
| Dot Length | 115 ms \pm 5% |
| Dash Length | 345 ms \pm 5% |
| Gap Length | 115 ms \pm 5% |
| Modulating Frequency | 1000 Hz \pm 50 Hz |

Table 28 - Modulation Characteristic Limits



2.10.7 Test Location and Test Equipment Used

This test was carried out in RF Laboratory 3.

| Instrument | Manufacturer | Type No. | TE No. | Calibration Period (months) | Calibration Expiry Date |
|------------------------|-----------------------|---------------------------|--------|-----------------------------|-------------------------|
| Attenuator (20dB, 10W) | Weinschel | 37-20-34 | 482 | 12 | 17-Jan-2023 |
| Hygrometer | Rotronic | I-1000 | 2891 | 12 | 04-Nov-2022 |
| Oscilloscope | Agilent Technologies | DSO9104A | 4142 | 12 | 13-Oct-2022 |
| Frequency Standard | Spectracom | SecureSync 1200-0408-0601 | 4393 | 6 | 30-Jun-2022 |
| PXA Signal Analyser | Keysight Technologies | N9030A | 4653 | 12 | 08-Mar-2023 |
| Cable (18 GHz) | Rosenberger | LU7-036-2000 | 5037 | - | O/P Mon |

Table 29

O/P Mon – Output Monitored using calibrated equipment



2.11 Spectrum Characteristics

2.11.1 Specification Reference

ISED RSS-287, Clause 7.4.5

2.11.2 Equipment Under Test and Modification State

RLB-44, S/N: TA000022 - Modification State 2

2.11.3 Date of Test

15-June-2022

2.11.4 Test Method

121.5 MHz Homing Transmitter

This test was performed in accordance with RSS-287, clause 6.5.

2.11.5 Environmental Conditions

Ambient Temperature 25.3 °C
Relative Humidity 35.0 %

2.11.6 Test Results

121.5 MHz Homing Transmitter

| Parameter | Result |
|---|--------|
| Total (Wideband) Power (dBm) | 14.134 |
| Power within the resolution bandwidth (dBm) | 9.807 |
| Difference (dB) | 4.327 |

Table 30 - Spectrum Characteristics

ISED RSS-287 Limit Clause 7.4.5

The total power in the resolution bandwidth shall not drop by more than 5 dB below the transmitter mean output power that is measured by a wideband meter, indicating that at least 30% of the power resides within the band $f_c \pm 30$ Hz (at 121.5 MHz) and within the band $f_c \pm 60$ Hz (at 243 MHz).



2.11.7 Test Location and Test Equipment Used

This test was carried out in RF Laboratory 3.

| Instrument | Manufacturer | Type No. | TE No. | Calibration Period (months) | Calibration Expiry Date |
|------------------------|-----------------------|---------------------------|--------|-----------------------------|-------------------------|
| Attenuator (20dB, 10W) | Weinschel | 37-20-34 | 482 | 12 | 17-Jan-2023 |
| Hygrometer | Rotronic | I-1000 | 2891 | 12 | 04-Nov-2022 |
| Frequency Standard | Spectracom | SecureSync 1200-0408-0601 | 4393 | 6 | 30-Jun-2022 |
| PXA Signal Analyser | Keysight Technologies | N9030A | 4653 | 12 | 08-Mar-2023 |
| Cable (18 GHz) | Rosenberger | LU7-036-2000 | 5037 | - | O/P Mon |

Table 31

O/P Mon – Output Monitored using calibrated equipment

3 Photographs

3.1 Test Setup Photographs

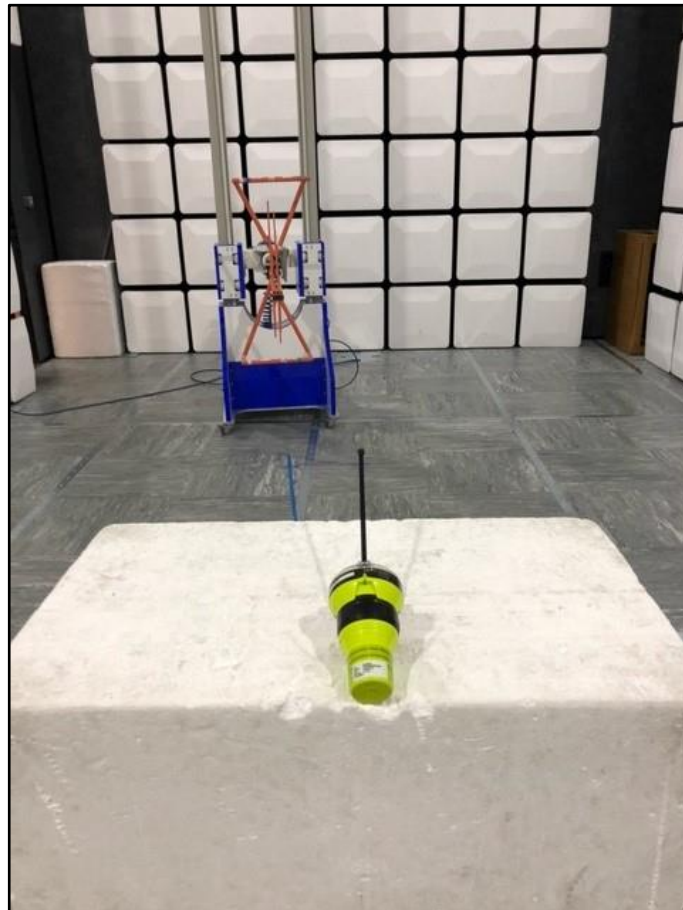

Figure 37 - 30 MHz to 1 GHz, X Orientation

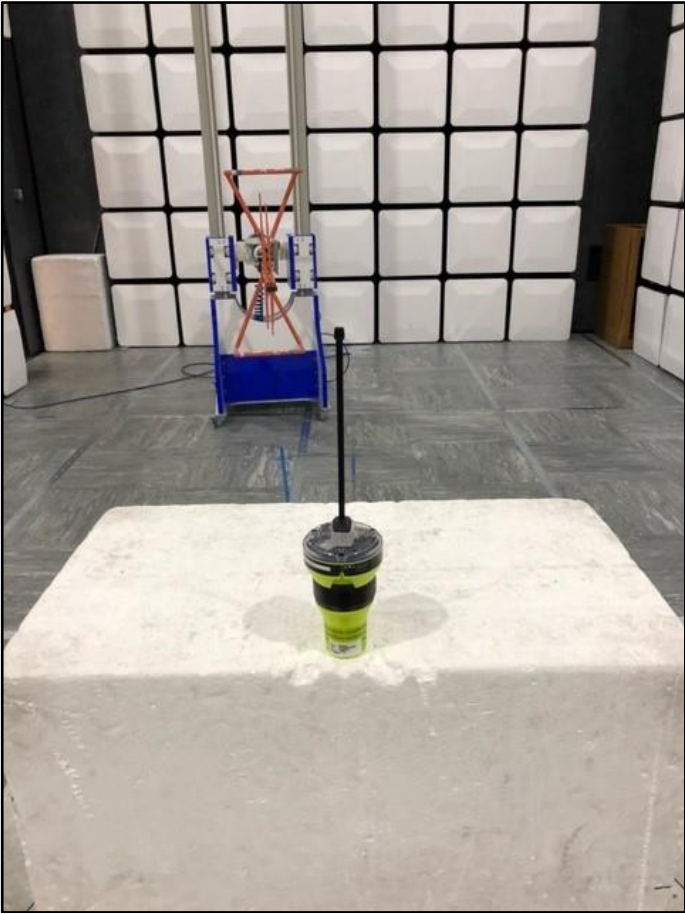

Figure 38 - 30 MHz to 1 GHz, Y Orientation

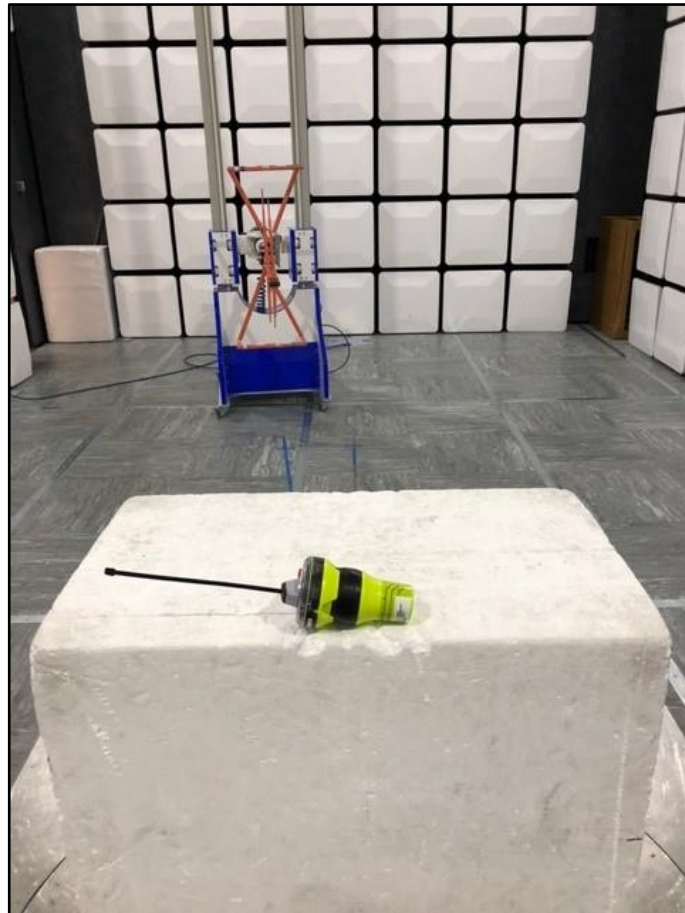

Figure 39 - 30 MHz to 1 GHz, Z Orientation



Figure 40 – 1 GHz to 2 GHz, X Orientation



Figure 41 – 1 GHz to 2 GHz, Y Orientation

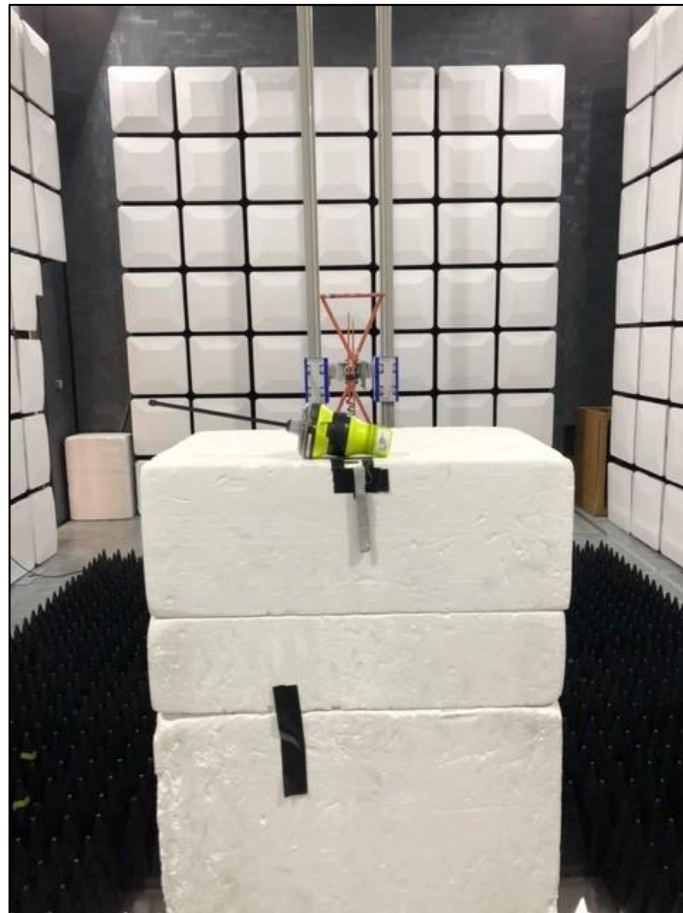

Figure 42 – 1 GHz to 2 GHz, Z Orientation



4 Measurement Uncertainty

For a 95% confidence level, the measurement uncertainties for defined systems are:

| Test Name | Measurement Uncertainty |
|---|---|
| Bandwidths | ± 58.05 Hz |
| Transmitter Frequency Tolerances | ± 11 Hz |
| Spurious Emissions at Antenna Terminals | ± 3.45 dB |
| Radiated Spurious Emissions | 30 MHz to 1 GHz: ± 5.2 dB 1 GHz to 18 GHz: ± 6.3 dB |
| Modulation Requirements | - |
| Transmitter Power | ± 3.2 dB |
| Bandwidths | ± 58.05 Hz |
| Transmitter Frequency Tolerances | ± 11 Hz |
| Spurious Emissions at Antenna Terminals | ± 3.45 dB |
| Radiated Spurious Emissions | 30 MHz to 1 GHz: ± 5.2 dB 1 GHz to 18 GHz: ± 6.3 dB |
| Modulation Characteristics | Minimum Audio Frequency: ± 22.4 Hz Maximum Audio Frequency: ± 121.56 Hz Audio Frequency Range: ± 123.6 Hz Sweep Repetition Rate: ± 5 % Modulation Factor: ± 5% Modulation Duty Cycle: ± 5% 30% Occupied Bandwidth: ± 5% |
| Transmitter Power | ± 3.2 dB |
| Spectrum Characteristics | ± 1.8 dB |

Table 32

Measurement Uncertainty Decision Rule – Accuracy Method

Determination of conformity with the specification limits is based on the decision rule according to IEC Guide 115:2007, Clause 4.4.3 and 4.5.1. (Procedure 2). The measurement results are directly compared with the test limit to determine conformance with the requirements of the standard.

Risk: The uncertainty of measurement about the measured result is negligible with regard to the final pass/fail decision. The measurement result can be directly compared with the test limit to determine conformance with the requirement (compare IEC Guide 115). The level of risk to falsely accept and falsely reject items is further described in ILAC-G8.



ANNEX A

Test Results from 75953445 Report 05

Physical Radio Tests

Specification Reference

IEC 61097-2, Clauses E.5.2 and E.5.3

Equipment Under Test and Modification State

RLB-44, S/N: TA000007 - Modification State 1

Date of Test

03-April-2022 & 23-April-2022 – IEC 61097-2 Clauses E.5.2 and E.5.3

Test Equipment Used

The major items of test equipment used for the above tests are identified in Section 3.1.

Environmental Conditions

Ambient Temperature 14.5 – 16.8°C
Relative Humidity 55.1 – 62.5 %

Test Setup

Off Ground Plane Radiated Power Test



Figure 43

On-Ground Plane Radiated Power Test



Figure 44

On-Ground Plane Radiated Power – Clause E.5.2

This test is only required to be performed at ambient temperature and shall use an EPIRB whose battery has been ON for a minimum of 44 h.

If the test exceeds 4 h, the battery may be replaced by another which has been pre-conditioned with at least 44 h of ON time.

The measurement procedure consists in a determination of 12 values of PERP made by direct measurement of radiated power.

The measurements are taken every $30^{\circ} \pm 3^{\circ}$ in azimuth from 0° to 360° . The starting point for the 12 azimuth measurements shall be defined by the manufacturer and shall be noted in the test report. All EIRP measurements shall be made at the same elevation angle; the elevation used shall be the angle between 5° and 20° for which the EPIRB exhibits a maximum antenna gain (Note this may not be the elevation at which maximum output is achieved). The nominal value of EIRP shall be 1 W (30 dBm) and the minimum level at any of the measurement points shall be 0,5 W (27 dBm).

The test site shall be on level ground, which has uniform electrical characteristics. The site shall be clear of metal objects, overhead wires, etc., and as free as possible from undesired signals such as ignition noise or RF carriers, for at least 30 m from the EPIRB, and the search antenna. The EPIRB shall be placed in the centre of a ground plane with a radius of no less than 75 cm.

The EPIRB shall be positioned vertically so that the nominal waterline of the EPIRB is level with the ground plane. The ground plane shall be resting on ground level and shall be extended so that it completely encloses and presents a snug fit to the portion of the EPIRB which is below the waterline.



Measurement of the radiated signals shall be made at a point 10 m from the EPIRB. At this point, a wooden pole or insulated tripod with a movable horizontal boom shall be arranged so that a search antenna can be raised and lowered through an elevation angle of 5° to 20°. The search antenna shall be mounted on the end of the boom with its cable lying horizontally on the boom and run back to the supporting mast. The other end of the search antenna cable shall be connected to a spectrum analyser located at the foot of the mast.

Off-Ground Plane Radiated Power – Clause E.5.3

This test is effectively a repeat of the EIRP test in E.5.2 except that the EPIRB is raised off the ground plane.

This test is only required to be performed at ambient temperature and shall use an EPIRB whose battery has been ON for a minimum of 44 h. If the test exceeds 4 h, the battery may be replaced with another which has been preconditioned with at least 44 h of ON time.

The measurement procedure includes a determination of four values of EIRP made by direct measurement of radiated power. Four measurements are taken every 90° ± 3° in azimuth. The four azimuth EIRP measurements shall be made at the same elevation angle; the elevation used shall be the angle between 5° and 20° for which the EPIRB exhibits a maximum antenna gain (it should be noted that this may not be the same elevation angle as that determined in E.5.1). The starting point for the four azimuth measurements shall be defined by the manufacturer and shall be noted in the test report. The nominal value of EIRP shall be 1 W (30 dBm) and the minimum level at any of the measurement points shall be 0,1 W (20 dBm).

The test site shall be the same as used in C/S T.007, Figure B.5 (note that this same test configuration is also used for the 121,5 MHz homer in SGBs as well as FGBs) except that the distance between the beacon under test and the RF receiver antenna shall be 10 m (instead of that in C/S T.007). The RF absorbing material (RAM) shall be positioned in such a way that the centre of the 3,6 m by 2,4 m section of RAM is positioned at the specular reflection point for the ground reflected path signal between the beacon under test and the RF receiver positioned at the elevation angle between 5° and 20° for which the EPIRB exhibits a maximum antenna gain. The EPIRB shall be placed upright on a non-conductive stand (for example a dry wooden or strong dry cardboard box) that raises the height of the base of the EPIRB 450 mm ± 25 mm above ground level.

Test Method

On-Ground Plane Radiated Power – Clause E.5.2

The elevation angle between 5° and 20° which produces a maximum gain is determined with the EPIRB at an arbitrary azimuth. The EIRP shall be measured, and the elevation angle noted and shall remain fixed for the remainder of the test. The remaining 11 measurements of EIRP may be obtained by rotating the EPIRB in increments of 30° ± 3°. For each measurement, the EPIRB's EIRP shall be computed using the following equation:

$$EIRP = 10^{\frac{(P_{REC} - G_{REC} + L_C + L_P)}{10}}$$

where:

P_{REC} is the measured power level from the spectrum analyser (dBm);

G_{REC} is the antenna gain of the search antenna (dB);

L_C is the receive system attenuator and cable loss (dB);

L_P is the free space propagation loss (dB).



Off-Ground Plane Radiated Power – Clause E.5.3

The elevation angle between 5° and 20° which produces a maximum gain is determined with the EPIRB at an arbitrary azimuth. The EIRP shall be measured, and the elevation angle noted and shall remain fixed for the remainder of the test. The remaining 3 measurements of EIRP may be obtained by rotating the EPIRB in increments of 90° ± 3°. For each measurement, the EPIRB's EIRP shall be computed using the following equation:

$$EIRP = 10^{\frac{(P_{REC} - G_{REC} + L_C + L_P)}{10}}$$

where:

- P_{REC} is the measured power level from the spectrum analyser (dBm);
- G_{REC} is the antenna gain of the search antenna (dB);
- L_C is the receive system attenuator and cable loss (dB);
- L_P is the free space propagation loss (dB).

Test Results

Battery Powered – AIS Homing Signal

On-Ground Plane Radiated Power – Clause E.5.2

| Azimuth (°) | EIRP at Elevation Producing Maximum Gain (mW) 7.91° |
|-------------|---|
| 0 | 903.82 |
| 30 | 914.29 |
| 60 | 916.39 |
| 90 | 877.17 |
| 120 | 912.18 |
| 150 | 887.32 |
| 180 | 849.34 |
| 210 | 912.18 |
| 240 | 847.39 |
| 270 | 903.82 |
| 300 | 877.17 |
| 330 | 853.26 |

IEC 61097-2, Limit Clause E.5.2.1

The nominal value of EIRP shall be 1 W (30 dBm) and the minimum level at any of the measurement points shall be 0.5 W (27 dBm)



Off-Ground Plane Radiated Power – Clause E.5.3

| Azimuth (°) | EIRP at Elevation Producing Maximum Gain (mW) 20° |
|-------------|---|
| 0 | 293.63 |
| 90 | 268.41 |
| 180 | 253.40 |
| 270 | 263.52 |

IEC 61097-2, Limit Clause E.5.3.1

The nominal value of EIRP shall be 1 W (30 dBm) and the minimum level at any of the measurement points shall be 0.1 W (20 dBm)

Summary

The EPIRB complies with Clauses E.5.2 and E.5.3 of IEC 61097-2:2021.



121.5 MHz Homing Device Tests

Specification Reference

IEC 61097-2:2021, Clause 2.14 - Annex D.

Equipment Under Test and Modification State

RLB-44, S/N: TA000007 - Modification State 1

Date of Test

03-April-2022 & 23-April-2022 – Clauses D.4.3 and D.4.4.

Test Method

The following tests were performed in accordance with BS IEC 61097-2:2021.

Peak Effective Radiated Power

This test was performed in accordance with BS IEC 61097-2:2021, Clause D.4.3.

Off Ground Plane Radiated Power Test

This test was performed in accordance with BS IEC 61097-2:2021, Clause D.4.4.

Environmental Conditions

| | |
|---------------------|----------------|
| Ambient Temperature | 14.5 – 26.1 °C |
| Relative Humidity | 36.1 – 62.5 % |



Test Results

121.5 MHz Homing Transmitter

Peak Effective Radiated Power

| Azimuth (°) | EIRP at Elevation Producing Maximum Gain (mW) 5.37° |
|-------------|---|
| 0 | 78.81 |
| 30 | 81.02 |
| 60 | 80.09 |
| 90 | 75.09 |
| 120 | 75.79 |
| 150 | 76.67 |
| 180 | 69.92 |
| 210 | 77.02 |
| 240 | 77.91 |
| 270 | 78.09 |
| 300 | 75.27 |
| 330 | 66.93 |

Table 33 - Measurements (Dipole Boresighted)

| Parameter | Result |
|--|------------------|
| Median value of PERP | 76.84 mW |
| Ratio of maximum to minimum of 11 highest values | 1.16:1 (0.41 dB) |

Table 34 - Peak Effective Radiated Power Results

BS IEC 61097-2:2021, Limit Clause D.4.3

The median value of PERP shall be between 25 mW and 100 mW
 The ratio of maximum to minimum of the 11 highest values of PERP shall not exceed 4 to 1 (6 dB).

Off Ground Plane Radiated Power Test

| Azimuth (°) | EIRP at Elevation Producing Maximum Gain (mW) 20° |
|-------------|---|
| 0 | 4.45 |
| 90 | 4.73 |
| 180 | 4.77 |
| 270 | 4.51 |

Table 35 - Measurements (Dipole Bore sighted)

BS IEC 61097-2:2021, Limit Clause D.4.4

The minimum value of PERP measured at each of the four azimuth angle increments shall be 2 mW.



ANNEX B

Manufacturer Supplied Documents



| | | |
|-------------------------|---|-----------------------|
| Technical Report | OSL Part No. | 9215-04397 |
| | Other Part No. | |
| Approved: | Issue | 01.00 |
| | Date Last Amended | 21/07/22 |
| | Last Amended by | Stefan Kennedy |
| Document Title | EPIRB3/V5 FCC Emissions Modification | |



Introduction:

During FCC Emissions testing at TUV SUD it was reported that the Ocean Signal EPIRB3 (TA00013/TSR003) and ACR V5 (TA00007/TSR004) were failing FCC Part 80, Clause 80.211 (f)(3) "Emissions Limitations" during AIS transmissions. The results provided suggested that the Radiated Emissions at some harmonic frequencies were exceeding the limit by up to 9.3dB.

Investigation:

These units were returned to Ocean Signal for investigation and the reported Radiated Emissions at the harmonic frequencies confirmed. It was observed that during the radiated AIS transmission turn-on period, a short transient pulse (~100us) was being generated at the start of the harmonic emissions. This was not seen when conducted measurements were made and only occurred when radiating from the antenna. Examples of these at the 2nd harmonic are shown in Fig.1 and Fig.2 for the EPIRB3 and V5 respectively.

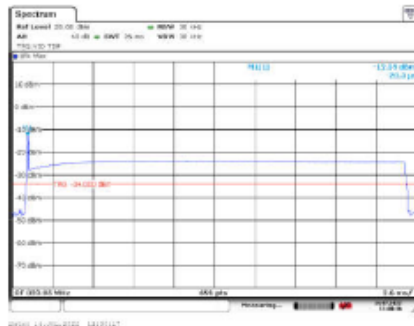

Fig.1: EPIRB3 2nd Harmonic Transient

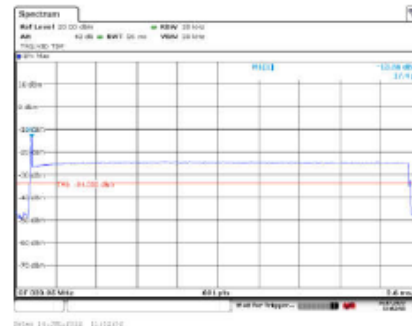

Fig.2: V5 2nd Harmonic Transient

Modification:

To limit the transient generation at the harmonic frequencies during the turn on period, the RF de-coupling provided by capacitor C164, at the gate bias of TR12 (AIS RF Power Amplifier), was increased. The value of C164 was changed from 47nF to 100nF. This is shown in Fig.3.

Company Confidential

Page 1 of 7
 Document Printed on 21/07/2022



| | | |
|-------------------------|---|-----------------------|
| Technical Report | OSL Part No. | 9215-04397 |
| | Other Part No. | |
| | Issue | 01.00 |
| | Date Last Amended | 21/07/22 |
| | Last Amended by | Stefan Kennedy |
| Document Title | EPIRB3/V5 FCC Emissions Modification | |

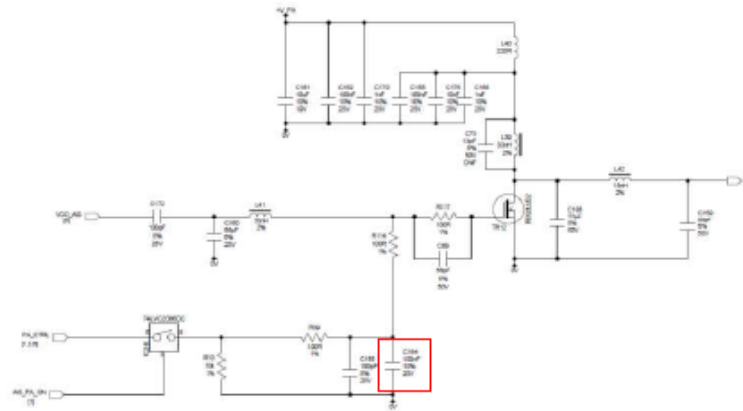

Fig.3: AIS RF PA Amplifier Stage showing increased decoupling capacitor C164 value

De-coupling Capacitor C164 does not affect the DC bias conditions of the PA amplifier and does not affect the RF power level generated. Evidence of this is shown in the results section of this document, which provides measurements of conducted and radiated power both before and after the value of C164 is changed. The AIS RF PA amplifier stage is only used for the AIS transmissions and is turned off at all other times. The 406MHz and 121.5 MHz transmissions are unaffected by this change as these both have separate transmitter stages.

Company Confidential

Page 2 of 7
 Document Printed on 21/07/2022



| | | |
|-------------------------|---|-----------------------|
| Technical Report | OSL Part No. | 9215-04397 |
| | Other Part No. | |
| | Issue | 01.00 |
| | Date Last Amended | 21/07/22 |
| | Last Amended by | Stefan Kennedy |
| Document Title | EPIRB3/V5 FCC Emissions Modification | |



Results:

EPIRB3 (TA00013/TSR003) Results

Fig.4 & Fig.5 show the EPIRB3 2nd harmonic Radiated Emissions with C164 unchanged (47nF) and then changed to 100nF.

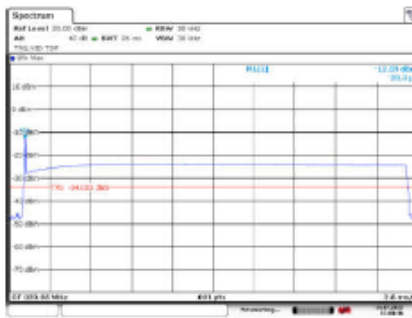

Fig.4: EPIRB3 2nd Harmonic Transient (C164: 47nF)

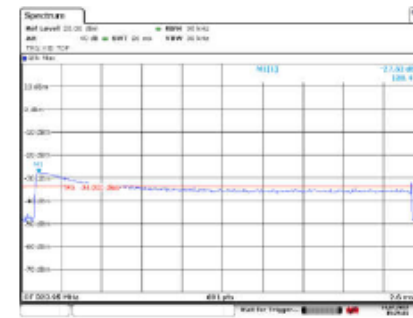

Fig.5: EPIRB3 2nd Harmonic Transient (C164: 100nF)

Fig.6 & Fig.7 show the EPIRB3 3rd harmonic Radiated Emissions with C164 unchanged (47nF) and then changed to 100nF

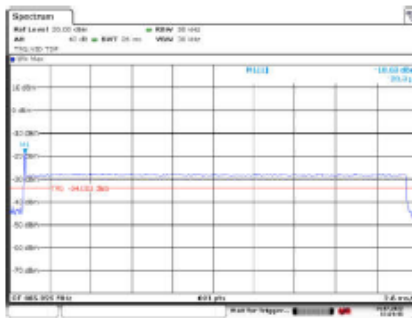

Fig.6: EPIRB3 3rd Harmonic Transient (C164: 47nF)

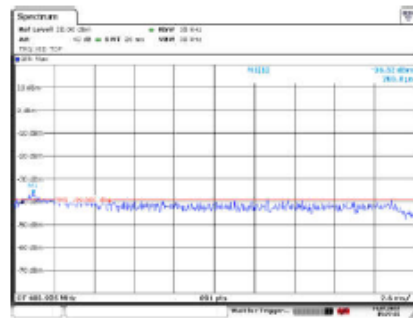

Fig.7: EPIRB3 3rd Harmonic Transient (C164: 100nF)

These results show that the transient is suppressed giving a ~15 to 18dB improvement in harmonic Emission level.

Company Confidential

Page 3 of 7
 Document Printed on 21/07/2022



| | | |
|-------------------------|---|-----------------------|
| Technical Report | OSL Part No. | 921S-04397 |
| | Other Part No. | |
| | Issue | 01.00 |
| | Date Last Amended | 21/07/22 |
| | Last Amended by | Stefan Kennedy |
| Document Title | EPIRB3/V5 FCC Emissions Modification | |



Fig.8 & Fig.9 show the EPIRB3 AIS Frequency Radiated Power with C164 unchanged (47nF) and then changed to 100nF. The Radiated Power after C164 is changed is within 0.05dB and therefore within measurement uncertainty.

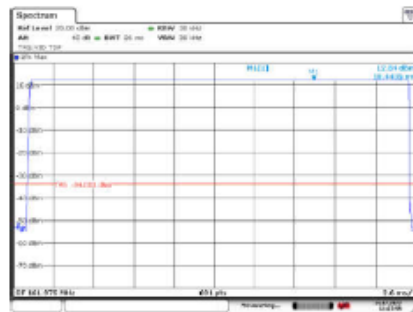

Fig.8: EPIRB3 AIS Radiated Power (C164: 47nF)

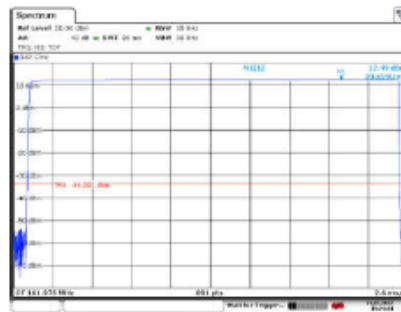

Fig.9: EPIRB3 AIS Radiated Power (C164: 100nF)

Fig.10 & Fig.11 show the EPIRB3 AIS Frequency Conducted Power with C164 unchanged (47nF) and then changed to 100nF. The Conducted Power after C164 is changed is within 0.02dB and therefore within measurement uncertainty.

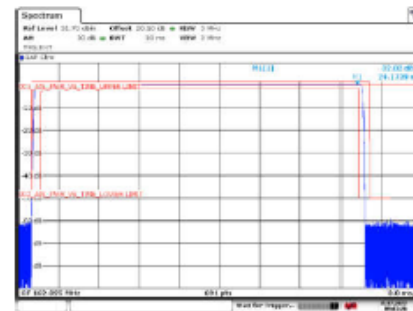

Fig.10: EPIRB3 AIS Conducted Power (C164: 47nF)

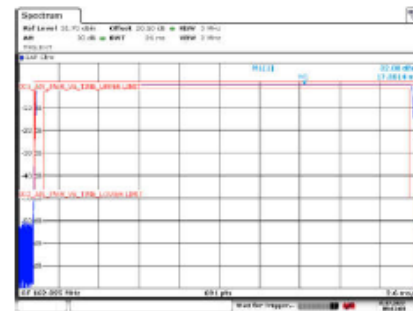

Fig.11: EPIRB3 AIS Conducted Power (C164: 100nF)

Company Confidential

Page 4 of 7
 Document Printed on 21/07/2022



| | | |
|-------------------------|---|-----------------------|
| Technical Report | OSL Part No. | 921S-04397 |
| | Other Part No. | |
| | Issue | 01.00 |
| | Date Last Amended | 21/07/22 |
| | Last Amended by | Stefan Kennedy |
| Document Title | EPIRB3/V5 FCC Emissions Modification | |



V5 (TA00007/TSR004) Results

Fig.12 & Fig.13 show the V5 2nd harmonic Radiated Emissions with C164 unchanged (47nF) and then changed to 100nF.

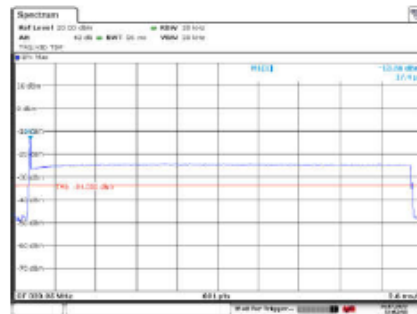

Fig.12: V5 2nd Harmonic Transient (C164: 47nF)

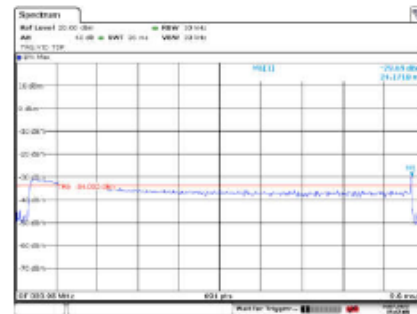

Fig.13: V5 2nd Harmonic Transient (C164: 100nF)

Fig.14 & Fig.15 show the V5 3rd harmonic Radiated Emissions with C164 unchanged (47nF) and then changed to 100nF.

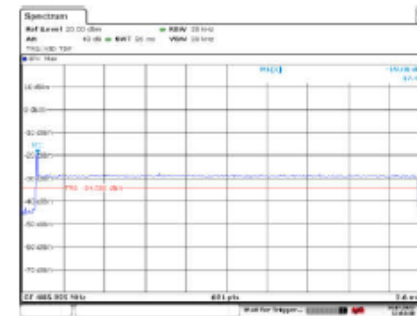

Fig.14: V5 3rd Harmonic Transient (C164: 47nF)

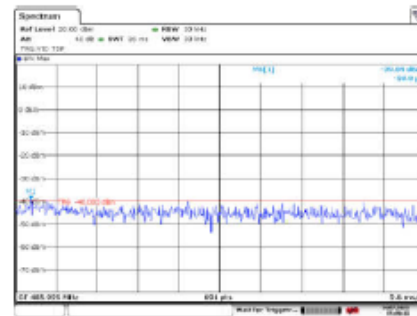

Fig.15: V5 3rd Harmonic Transient (C164: 100nF)

These results show a ~16 to 20dB improvement in harmonic Emission level.

Company Confidential

Page 5 of 7
 Document Printed on 21/07/2022



| | | |
|-------------------------|---|-----------------------|
| Technical Report | OSL Part No. | 921S-04397 |
| | Other Part No. | |
| | Issue | 01.00 |
| | Date Last Amended | 21/07/22 |
| | Last Amended by | Stefan Kennedy |
| Document Title | EPIRB3/V5 FCC Emissions Modification | |



Fig.16 & Fig.17 show the V5 AIS Frequency Radiated Power with C164 unchanged (47nF) and then changed to 100nF. The Radiated Power after C164 is changed is within 0.07dB and therefore within measurement uncertainty.

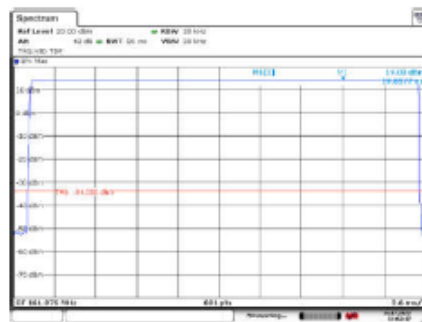

Fig.16: V5 AIS Radiated Power (C164: 47nF)

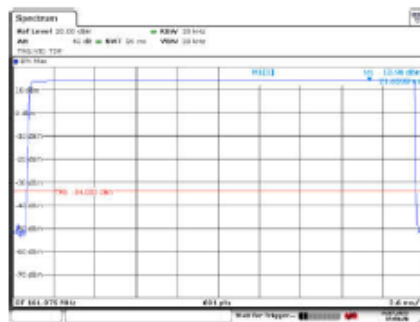

Fig.17: V5 AIS Radiated Power (C164: 100nF)

Fig.18 & Fig.19 show the V5 AIS Frequency Conducted Power with C164 unchanged (47nF) and then changed to 100nF. The Conducted Power after C164 is changed is within 0.01dB and therefore within measurement uncertainty.

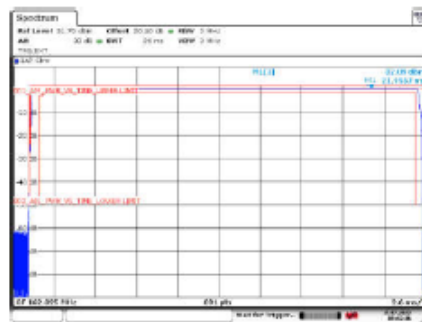

Fig.18: V5 AIS Conducted Power (C164: 47nF)

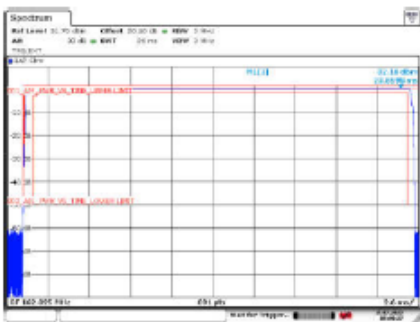

Fig.19: V5 AIS Conducted Power (C164: 100nF)



| | | |
|-------------------------|---|-----------------------|
| Technical Report | OSL Part No. | 9215-04397 |
| | Other Part No. | |
| | Issue | 01.00 |
| | Date Last Amended | 21/07/22 |
| | Last Amended by | Stefan Kennedy |
| Document Title | EPIRB3/V5 FCC Emissions Modification | |



Conclusion:

These results demonstrate that the modification made makes a significant improvement to the harmonic emission transients. The modification, which increases the value of RF decoupling capacitor C164, does not affect the DC operating conditions about the PA amplifier and therefore does not change the operating current or power output - It can be seen that the conducted and radiated power at the AIS frequencies is unchanged when the value of C164 is increased. Capacitor C164 is in the AIS transmitter circuit which is only used for AIS transmissions and has no effect on any other circuits, including the 406MHz and 121.5MHz transmitters.

Company Confidential

Page 7 of 7
 Document Printed on 21/07/2022

