

APPLICANT:
Ericsson Radio System AB

EXHIBIT 8
Page 1

FCC ID NO.
B5KKRC12103-31

EXHIBIT 8 - COVER SHEET

Table of Contents

Description RBS 884-1900

27 pages

Uppgjord - Prepared ERA/AR/SL KSN	Faktaansvarig - Subject responsible	Nr - No 28/1551-ANT 244 01 Uen		
Dokansv/Godk - Doc respons/Approved ERA/AR/SLC (L-O Sundell)	Kontr - Checked	Datum - Date 1996-03-29	Rev A	File

RBS 884-1900

Abstract

The hardware structure of the macro base station RBS 884-1900 is described in this document. RBS 884-1900 is designed for D-AMPS 1900.

Application

This description applies to MBS in CMS 88.

The limitations on the Friendly User System are mentioned separately.

Uppgjord - Prepared ERA/AR/SL KSN	Faktaansvarig - Subject responsible	Nr - No 28/1551-ANT 244 01 Uen	
Dokansv/Godk - Doc respons/Approved ERA/AR/SLC (L-O Sundell)	Kontr - Checked	Datum - Date 1996-03-29	Rev A

Table of Contents

1	Introduction	3
2	D-AMPS 1900	3
3	MBS	4
4	Base Station Structure	4
4.1	Control Part	4
4.2	RF Block Diagrams	7
4.3	Modem Part	13
4.4	Antenna Near Part	14
4.5	Support Part	17
4.6	Building Practice	18
5	Interfaces	18
5.1	External BS Interfaces	18
5.2	Internal BS Interfaces	19
6	Performance	21
6.1	Radio Network Characteristics	21
6.2	Radio Performance	21
6.3	Environmental Characteristics	21
6.4	Transmission Performance	21
6.5	Power Consumption	22
6.6	Traffic Capacity	22
7	Functions	22
7.1	Traffic	22
7.2	Operation and Maintenance	22
8	Placing of Cabinets	23
9	Co-siting	24
10	Terminology	24
11	References	25
12	Revision Information	27

Uppgjord - Prepared ERA/AR/SL KSN	Faktaansvarig - Subject responsible	Nr - No 28/1551-ANT 244 01 Uen
Dokansv/Godk - Doc respons/Approved ERA/AR/SLC (L-O Sundell)	Kontr - Checked	Datum - Date 1996-03-29
		Rev A
		File

1 INTRODUCTION

The base station RBS 884-1900 is designed for D-AMPS 1900, which is an all digital system. The air interface standard is defined by PN3388.

The building practice of RBS 884-1900 is the same as for the macro base station RBS 884. The transceiver and the antenna near parts of RBS 884-1900 are new designs, while the control part of RBS 884 is reused.

The purpose of this document is to give an overview of the hardware structure of the base station. A number of references are mentioned, where more detailed information on the hardware, the interfaces, and the performance can be found.

2 D-AMPS 1900

The frequency band used for D-AMPS 1900 is divided into six bands according to table 1. The following bands and combinations of bands are supported by the base station: A, B, C, D, E, F, A+D, D+B, B+E, F+C, and E+F.

Table 1. Frequency band D-AMPS 1900

Band	Bandwidth [MHz]	No. of channels	RX band [MHz]	TX band [MHz]
A	15	497	1850-1865	1930-1945
D	5	164	1865-1870	1945-1950
B	15	498	1870-1885	1950-1965
E	5	165	1885-1890	1965-1970
F	5	164	1890-1895	1970-1975
C	15	497	1895-1910	1975-1990

In addition to the channels specified above, there are 12 channels that do not entirely fall into a single band. These channels are also supported by the base station, so in all there are 1997 channels available.

The transceiver is designed for the entire band (1850-1910, 1930-1990). The ANP units except the autotuned combiner and some filters (see 4.4.2, 4.4.3) cover the entire band as well.

It is possible for an operator to have two non-consecutive bands. In that case, two separate antenna systems must be used.

Uppgjord - Prepared ERA/AR/SL KSN	Faktaansvarig - Subject responsible	Nr - No 28/1551-ANT 244 01 Uen
Dokansv/Godk - Doc respons/Approved ERA/AR/SLC (L-O Sundell)	Kontr - Checked	Datum - Date 1996-03-29
		Rev A
		File

3 MBS

The subsystem MBS handles the communication between the MSC and the mobile station. MBS consists of both hardware and software in the MSC and in the base station. An outline of MBS is shown in figure 1. Note, the group switch (GS) does not belong to MBS.

Figure 1. MBS hardware structure.

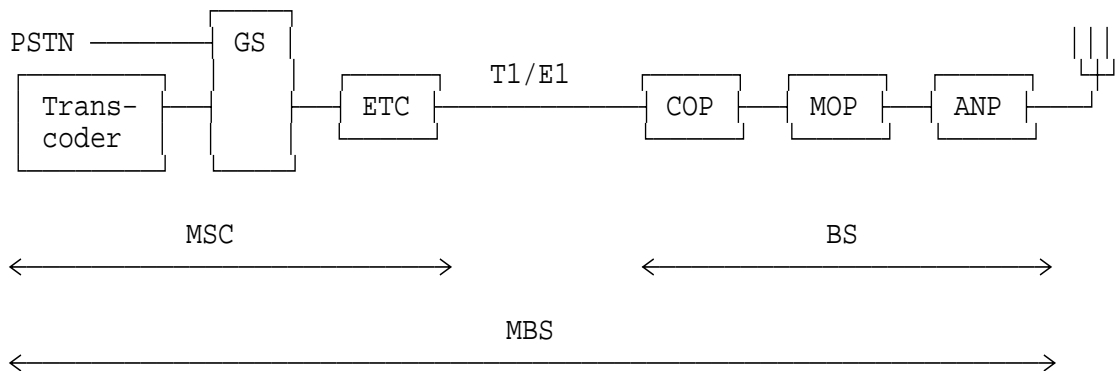

Besides the control part (COP), the modem part (MOP), and the antenna near part (ANP), the base station contains a support part (SUP).

In this document the base station part of MBS is described.

4 BASE STATION STRUCTURE

4.1 CONTROL PART

The control part communicates with the MSC and it also controls the MOP, ANP, and SUP.

In the macro base station, the control part consists of the CRI. A block diagram of the CRI is shown in figure 2.

Uppgjord - Prepared ERA/AR/SL KSN	Faktaansvarig - Subject responsible	Nr - No 28/1551-ANT 244 01 Uen
Dokansv/Godk - Doc respons/Approved ERA/AR/SLC (L-O Sundell)	Kontr - Checked	Datum - Date 1996-03-29
		Rev A
		File

Figure 2. CRI

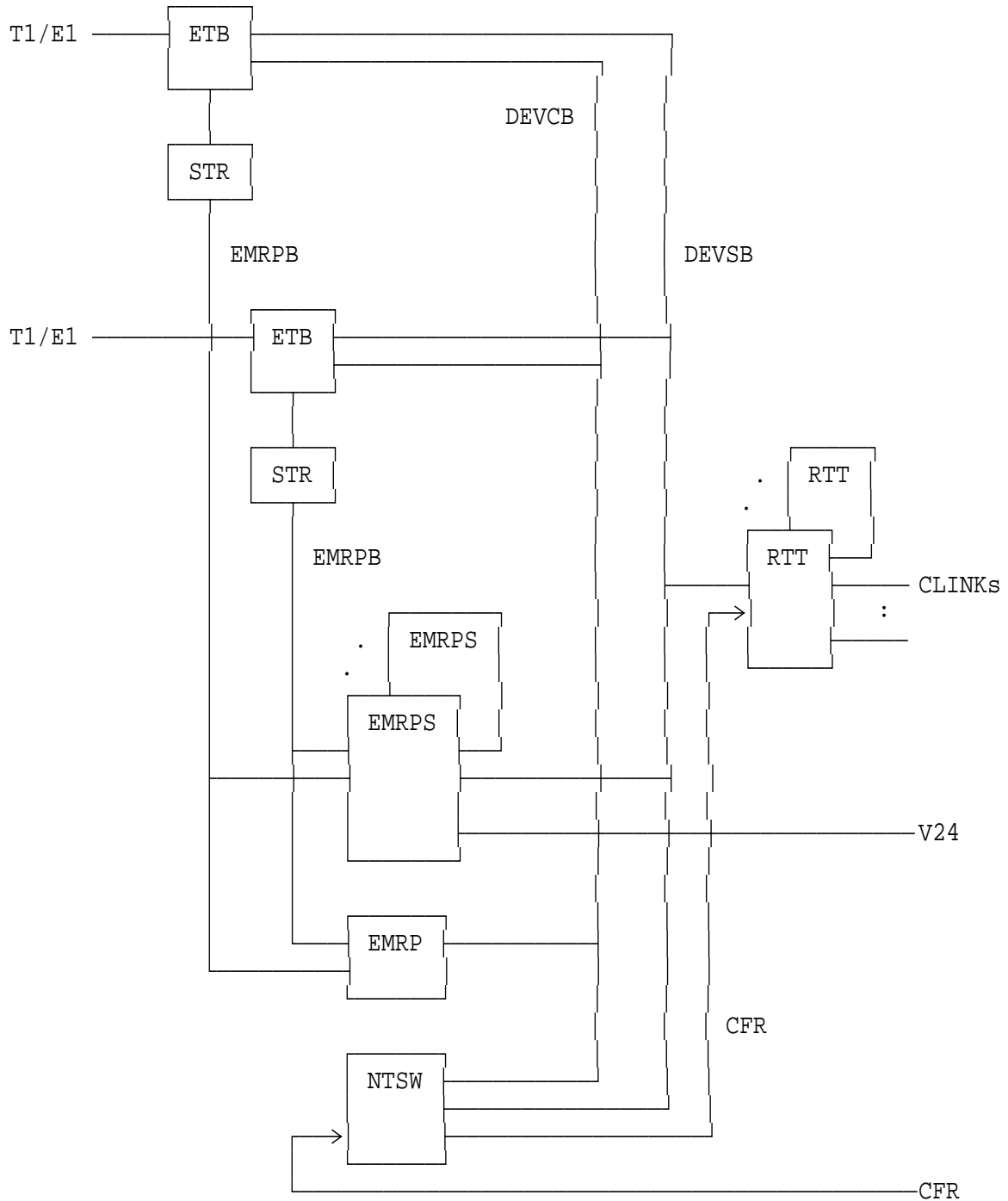

Uppgjord - Prepared ERA/AR/SL KSN	Faktaansvarig - Subject responsible	Nr - No 28/1551-ANT 244 01 Uen		
Dokansv/Godk - Doc respons/Approved ERA/AR/SLC (L-O Sundell)	Kontr - Checked	Datum - Date 1996-03-29	Rev A	File

There are two versions of the ETB. ETB24 is used for 1.544 Mbit/s PCM links and ETB32 for 2.048 Mbit/s PCM links. It is possible to connect two PCM links to the CRI. However, in D-AMPS 1900 where all the channels are digital, the CRI cannot carry traffic from more than one PCM link.

The STR handles the signalling to and from the MSC. Depending on the PCM system used, the control signals are sent in time slot number 9 or number 16. In ETB24 it is time slot number 9 that can be extracted and forwarded to the STR, and in ETB32 it is time slot number 16.

The EMRP controls the time switch (NTSW) and the ETB.

The NTSW switches the time slots. The time slots contain control signals or speech.

The EMRPS controls the devices in the base station and it collects the internal CRI alarms from the DC/DC converter and the fans. The EMRPS also has an operator interface (V24).

The devices that are controlled by the EMRPS are connected through CLINKs. The CLINK is a 2.048 Mbit/s communication interface (32 time slots numbered 0-31, 64 kbit/s/time slot). Each RTT board has 8 CLINK connections. The following devices in MOP and ANP are controlled by the EMRPS: TRX, TIM, CTC, RFTL, and ALM.

Between the EMRPS and the TRX, both speech and control signals are transferred on the CLINK. The control signals are sent in time slot 0 and the speech is sent in time slot 1.

The carrier frequency reference is generated by TIM. The data on the CLINK is clocked by the CFR. The data to and from the NTSW is clocked by the NTSW clock. The carrier frequency generators on TRX and RFTL use the CLINK clock as reference. The CLINK clock and the CLINK data have the same stability as the CFR.

The EMRPS/EMRP software is loaded from the MSC and it is stored in RAM.

In the CRI there is one redundant EMRPS. To bring this unit into operation, a reconfiguration has to be done manually from the MSC. The EMRP, the NTSW, and the RTT cannot be duplicated. There are two fans in the cabinet, one fan is sufficient to keep the temperature within the allowed range.

Reference [1] contains more information on the control part.

Uppgjord - Prepared	Faktaansvarig - Subject responsible	Nr - No		
ERA/AR/SL KSN		28/1551-ANT 244 01 Uen		
Dokansv/Godk - Doc respons/Approved	Kontr - Checked	Datum - Date	Rev	File
ERA/AR/SLC (L-O Sundell)		1996-03-29	A	

Friendly User System: TIM is not used. NTSW is replaced by RITSW. In order to maintain the stability of the carrier frequency, there will be restrictions on the transmission lines regarding jitter and wander.

4.2 RF BLOCK DIAGRAMS

The RF part of the base station includes the transceivers and the antenna near part.

There are two types of antenna configurations:

- antennas with duplex filter
- separate TX and RX antennas

The base station is designed to handle 32 carriers per cell. Up to 16 carriers can be connected to the same antenna. When 17-32 carriers are used, two antennas will be needed if the RF power output level should be maintained.

The following configurations are shown in the block diagrams:

- One antenna with duplex filter, 16 carriers (figure 3)
- Separate TX and RX antennas, 16 carriers (figure 4)
- Two antennas with duplex filter, 32 carriers (figure 5)
- Separate TX and RX antennas, 32 carriers (figure 6)
- Two antennas with duplex filter but without LNA, 32 carriers (figure 7)

The reference points indicated in figure 3 show where the radio performance of the base station is defined. If LNAs are used, the reference point is the mast-head and otherwise it is the antenna feeder.

Figure 3-6: The LNAs and the filters in front of the LNAs (DPX or RXBP) are placed at the mast-head and the other units are placed in the base station.

Figure 7: All the units are placed in the base station.

Friendly User System: Only separate TX and RX antennas.

Uppgjord - Prepared ERA/AR/SL KSN	Faktaansvarig - Subject responsible	Nr - No 28/1551-ANT 244 01 Uen
Dokansv/Godk - Doc respons/Approved ERA/AR/SLC (L-O Sundell)	Kontr - Checked	Datum - Date 1996-03-29
		Rev A
		File

Figure 3. One antenna with duplex filter, 16 carriers.

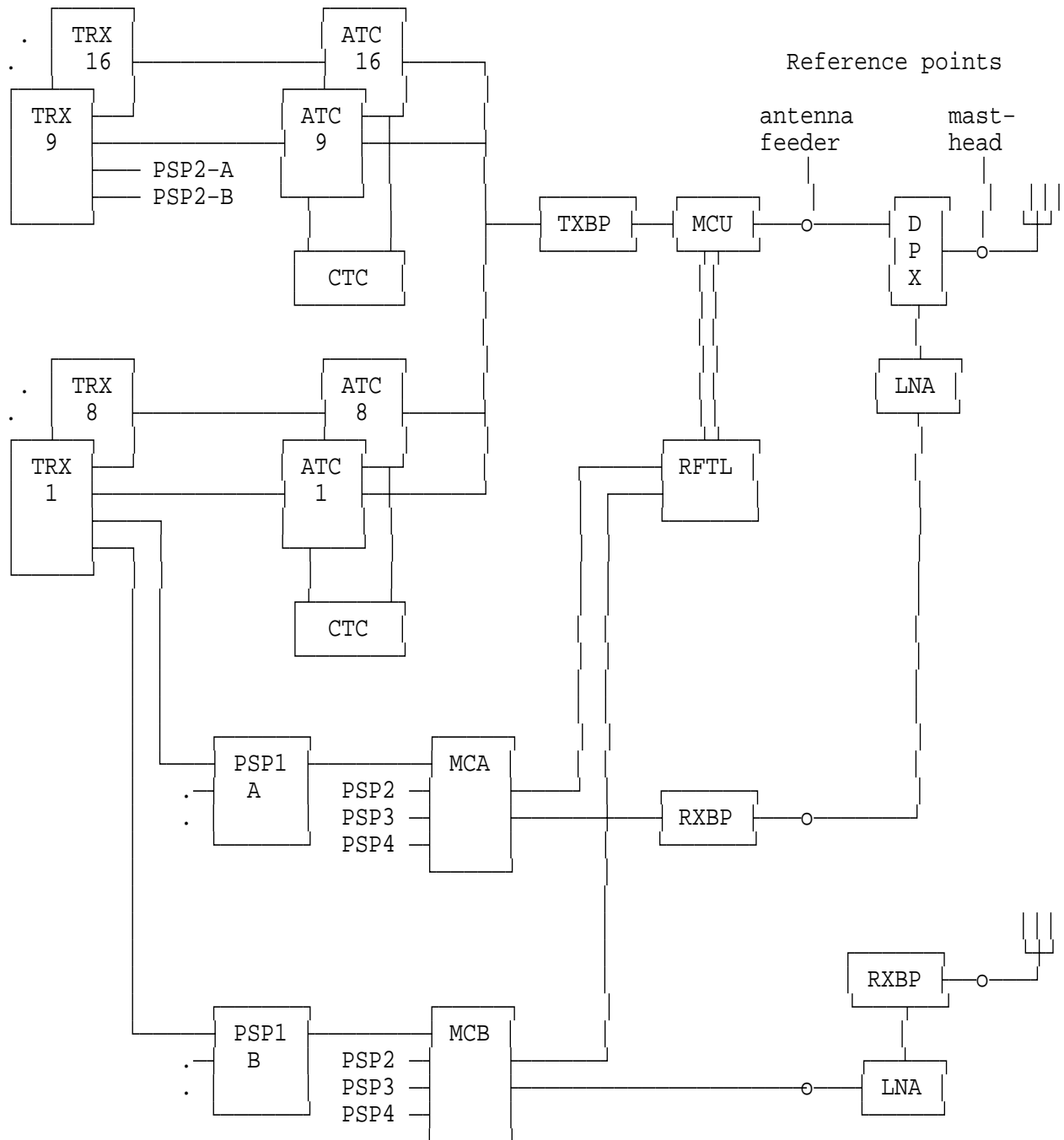

Uppgjord - Prepared ERA/AR/SL KSN	Faktaansvarig - Subject responsible	Nr - No 28/1551-ANT 244 01 Uen
Dokansv/Godk - Doc respons/Approved ERA/AR/SLC (L-O Sundell)	Kontr - Checked	Datum - Date 1996-03-29
		Rev A
		File

Figure 4. Separate TX and RX antennas, 16 carriers.

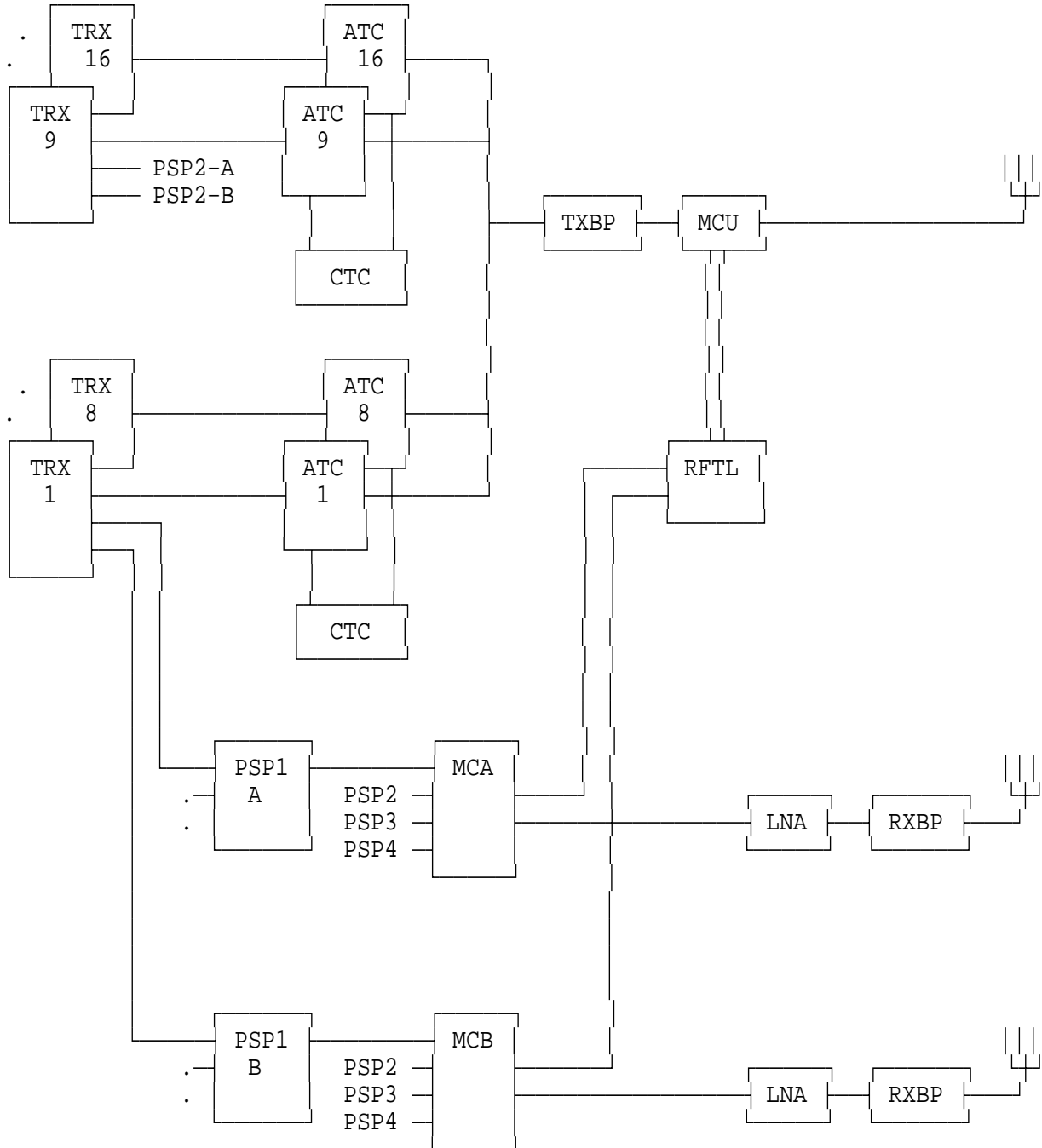

Uppgjord - Prepared ERA/AR/SL KSN	Faktaansvarig - Subject responsible	Nr - No 28/1551-ANT 244 01 Uen
Dokansv/Godk - Doc respons/Approved ERA/AR/SLC (L-O Sundell)	Kontr - Checked	Datum - Date 1996-03-29
		Rev A
		File

Figure 5. Two antennas with duplex filter, 32 carriers.

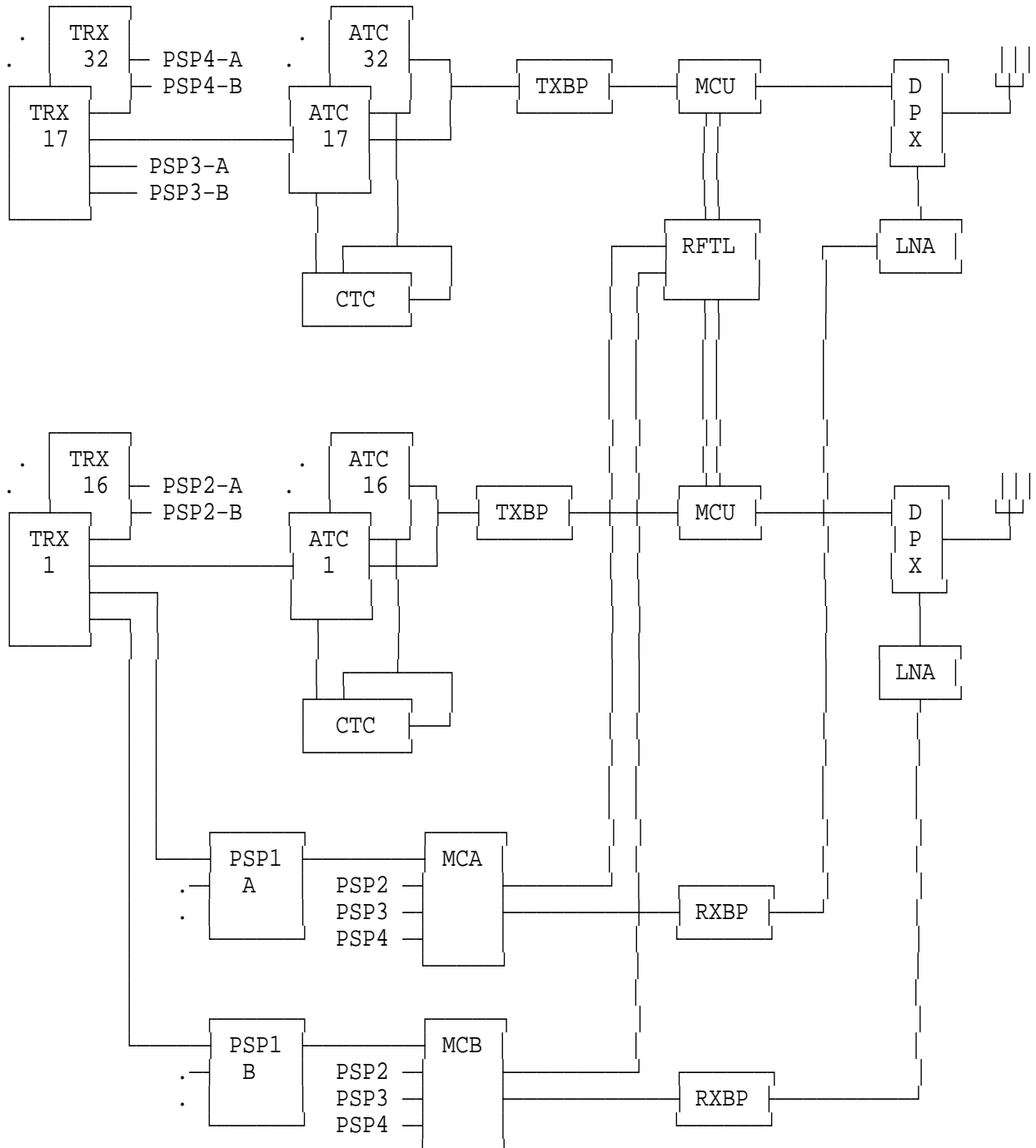

Uppgjord - Prepared ERA/AR/SL KSN	Faktaansvarig - Subject responsible	Nr - No 28/1551-ANT 244 01 Uen
Dokansv/Godk - Doc respons/Approved ERA/AR/SLC (L-O Sundell)	Kontr - Checked	Datum - Date 1996-03-29
		Rev A
		File

Figure 6. Separate TX and RX antennas, 32 carriers.

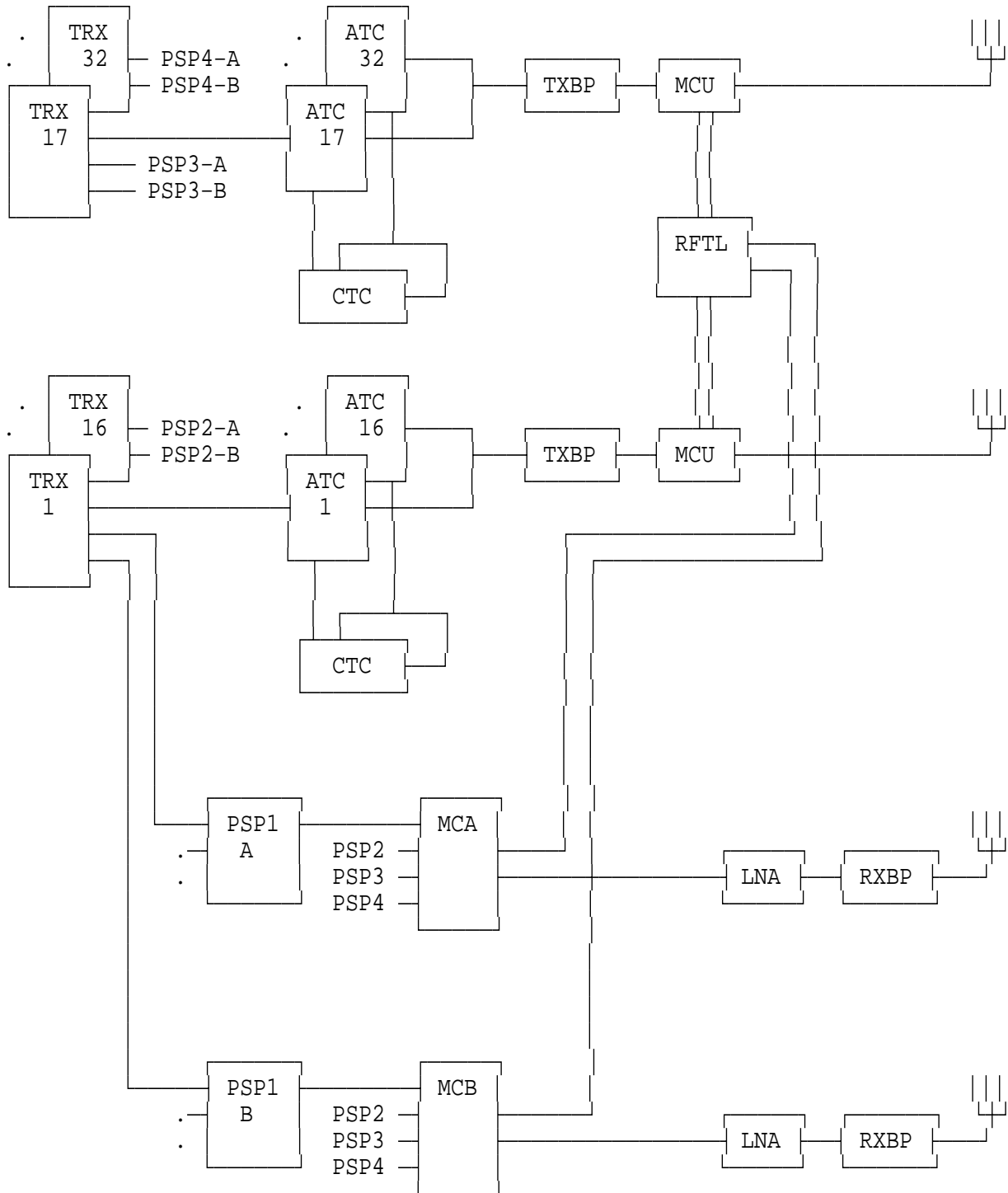

Uppgjord - Prepared ERA/AR/SL KSN	Faktaansvarig - Subject responsible	Nr - No 28/1551-ANT 244 01 Uen
Dokansv/Godk - Doc respons/Approved ERA/AR/SLC (L-O Sundell)	Kontr - Checked	Datum - Date 1996-03-29
		Rev A
		File

Figure 7. Two antennas with duplex filter but without LNA, 32 carriers.

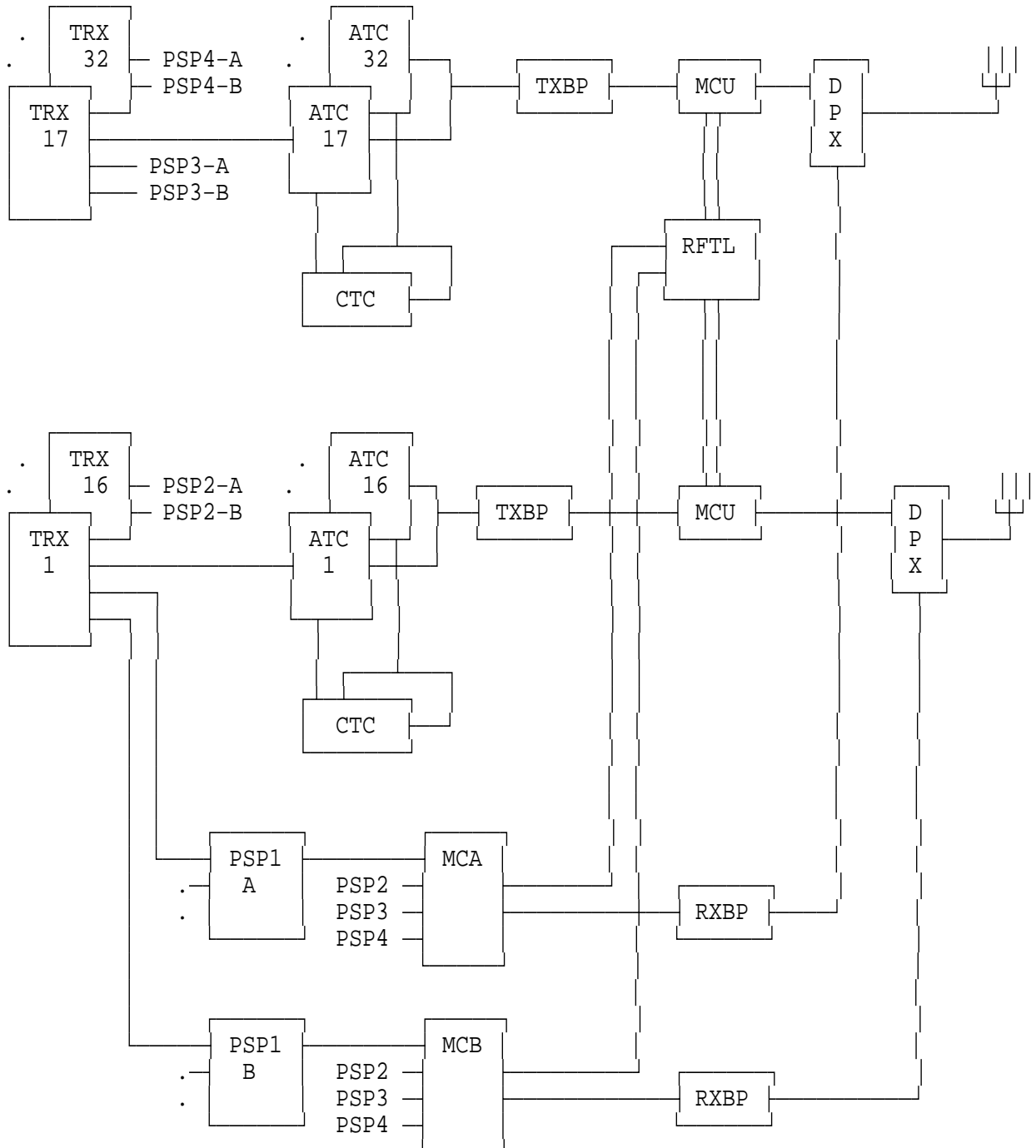

Uppgjord - Prepared ERA/AR/SL KSN	Faktaansvarig - Subject responsible	Nr - No 28/1551-ANT 244 01 Uen	
Dokansv/Godk - Doc respons/Approved ERA/AR/SLC (L-O Sundell)	Kontr - Checked	Datum - Date 1996-03-29	Rev A File

4.3 MODEM PART

The modem part consists of the TRX and the TIM.

The TRX performs the channel coding/decoding, interleaving/deinterleaving, wave form generation, power amplification, RF detection, equalization, and data detection. In order to get a measure of the quality of the radio channel, the TRX contains a number of detectors (RSSI, BER, residual BER, FER, frequency error, fading frequency, time synchronization error, burst quality). The speech coding/decoding is done by the transcoder (TRAB) in the MSC.

Any TRX can be assigned any channel function (DTC, DCCH, DVER).

The RF power output of the transceiver is 30 W. There are maximum 8 TRXs per TCB. The TRXs in one cabinet can be allocated to one or two cells.

The TRXs are located in the TCB along with the power splitter and two types of connection boards (DCON and PFCON). The CLINK and the AFS are connected through the DCON board to the TRXs (via the backplane). These signals are converted from balanced signals to unbalanced signals on the DCON board. The following signals are connected through the PFCON board: power, CID, and fan alarm.

The TIM generates the carrier frequency reference and the air frame synchronization signal. Internal AFS means that the carriers in one base station site are TDMA frame and slot synchronized. External AFS means that the carriers in several sites are synchronized. The hardware is prepared for AFS but there is not yet any software support for AFS.

The TIM is duplicated and the TIM boards are located in the ANPC (4.4.3).

The carrier frequency reference is 64 kHz and it has a stability of +/-0.1 ppm. An air frame synchronization signal is generated every 40 ms. The synchronization and the carrier frequency stabilization are described in reference [7].

The device software is loaded from the MSC via the EMRPS and it is stored in non-volatile memories on TRX and TIM respectively.

Reference [2] contains more information on the modem part. The base station detectors are described in reference [11].

Uppgjord - Prepared ERA/AR/SL KSN	Faktaansvarig - Subject responsible	Nr - No 28/1551-ANT 244 01 Uen	
Dokansv/Godk - Doc respons/Approved ERA/AR/SLC (L-O Sundell)	Kontr - Checked	Datum - Date 1996-03-29	Rev A File

Friendly User System: Maximum 4 TRXs for traffic and 2 TRXs for verification per TCB. TIM is not used.

4.4 ANTENNA NEAR PART

4.4.1 General

The antenna near part consists of ALM and all the units shown in the RF block diagrams (figure 3-7) except the TRXs.

The main functions of the ANP are listed below.

- combination of the output signals from the TRXs
- filtering of the TX and RX signals
- preamplification and distribution of the RX signals
- protect the TRXs from high reflected power
- provide isolation between the TRXs
- calibration and supervision

The ANP products are located in the ATCC, ANPC, TCB, and at the mast-head.

An overview of the ANP is given below and more information can be found in reference [3].

4.4.2 ATCC

The ATCC contains a number of autotuned combiners, a control unit for the combiners, a TX filter, and an MCU.

The ATC is a waveguide combiner. There are maximum 8 ATCs per ATCC. The number of ATCs can be increased by two at a time.

It is possible to connect up to 16 ATCs to the same antenna. In such a configuration with two ATCCs, ATCC1 is fully equipped (8 ATCs, CTC, TX filter, MCU) while ATCC2 contains 8 ATCs and a CTC only.

In the standard configuration, the ATCs in one ATCC are connected to the same antenna (cell). If required, the ATCs can be allocated to two cells. There is a special version of the ATCC (ATCC1D) for that case. ATCC1D contains 8 ATCs, 1 CTC, 2 TX filters, and 2 MCUs.

The tuning range per combiner is 25 MHz. To be able to support all the combinations of frequency bands mentioned in section 2, the ATC products have the following tuning ranges: 1930-1955 MHz (channel no. 2-832), 1945-1970 MHz (channel no. 499-1334), and 1965-1990 MHz (channel no. 1166-1998).

Uppgjord - Prepared ERA/AR/SL KSN	Faktaansvarig - Subject responsible	Nr - No 28/1551-ANT 244 01 Uen	
Dokansv/Godk - Doc respons/Approved ERA/AR/SLC (L-O Sundell)	Kontr - Checked	Datum - Date 1996-03-29	Rev A File

The passband of TXBP covers the entire TX band (1930-1990 MHz).

The CTC controls the tuning of the ATCs, so that the RF power output becomes the highest possible. The CTC measures the RF power via the measuring coupler unit.

The channel number and the power level of the TRX are reported from the MSC to the CTC. The initial tuning is performed on a CW signal. During operation the CTC supervises the ATCs. To compensate for temperature changes etc, the fine tuning of the ATCs is performed continuously. The CTC cannot be duplicated. In case of a CTC failure, the ATCs will keep their current tuning but the fine tuning will not work. The ATCs cannot be tuned to any new frequencies when the CTC is faulty.

The device software of the CTC is loaded from the MSC via the EMRPS and it is stored in a non-volatile memory.

The internal alarm from the fan unit is collected by the CTC. There are two fans in the ATCC for redundancy reasons.

4.4.3 ANPC

The ANPC contains the multicouplers (MCA, MCB), ALM, RFTL, TIM, and a connection board (POC) for power, CID and fan alarm. RFTL is optional. RX filters are also placed in the ANPC.

In the configuration shown in figure 7, the filters DPX and RXBP are placed in the base station. There is no space in the ANPC for the duplex filters so they are placed in a separate cabinet (DPXC).

There are two versions of the ANPC, ANPC1 and ANPC2 respectively. ANPC1 contains all the units needed in one cell and ANPC2 contains the units needed for two additional cells. ANPC2 does not contain any TIM since it is sufficient to have TIM in one ANPC per site.

The multicouplers have four outputs (PSP1-PSP4 in figure 3-7). These outputs are connected to the power splitters, which are located in the TCBs. The multicouplers have two different gains, depending on whether LNAs are used or not. The purpose is to have a fixed gain from the reference point to the input of the TRX.

There is one ALM in ANPC1 and ANPC2 respectively. The ALM can collect 32 external alarms and it has 8 outputs for control of external equipment. Presently, there is

Uppgjord - Prepared ERA/AR/SL KSN	Faktaansvarig - Subject responsible	Nr - No 28/1551-ANT 244 01 Uen	
Dokansv/Godk - Doc respons/Approved ERA/AR/SLC (L-O Sundell)	Kontr - Checked	Datum - Date 1996-03-29	Rev A File

no software support for control of any external equipment. The internal alarms from the multicouplers, the fan unit, and the LNAs are connected to the ALM as well.

For the RX filter (RXBP) the bandwidth of the passband is 15 MHz and for the duplex filter (DPX) the bandwidth is 15 MHz or 60 MHz. The following narrow band filters are available: A band (channel no. 2-501), B band (channel no. 666-1167) and C band (channel no. 1499-1998). The wide band filter covers the entire RX band (1850-1910 MHz).

The table below shows what combinations of filters that are valid. The filters are identified by their bandwidth.

	DPX	RXBP (mast-head)	RXBP (BS)
with LNA	15 MHz	-	15 MHz
	-	15 MHz	-
without LNA	60 MHz	-	15 MHz
	-	-	15 MHz

There is one RFTL board per cell. The functions listed below are performed by RFTL.

- power measurement
- return loss measurement
- RSSI calibration
- TRX loop test

All these functions are prepared in the hardware but the software only supports the functions "power measurement" and "return loss measurement". The "RSSI calibration" is replaced by the function "RSSI measurement". The output power is measured at the antenna feeder (figure 3), no matter where the reference point for the radio performance is defined. The return loss is measured on the TX antenna.

The device software is loaded from the MSC via the EMRPS and it is stored in non-volatile memories on ALM and RFTL respectively.

In the ANPC, it is only the TIM and the fans that are duplicated. If an error occurs in any of the multi-couplers, the base station still works but with reduced radio performance. A fault in ALM or RFTL does not prevent the traffic handling, but the supervision will be reduced.

Friendly User System: The LNA alarms will not be forwarded from the ALM board to the MSC. There is no DPXC.

Uppgjord - Prepared ERA/AR/SL KSN	Faktaansvarig - Subject responsible	Nr - No 28/1551-ANT 244 01 Uen	
Dokansv/Godk - Doc respons/Approved ERA/AR/SLC (L-O Sundell)	Kontr - Checked	Datum - Date 1996-03-29	Rev A File

4.4.4 Mast-Head Equipment

At 1900 MHz, the attenuation of the RF signal is much higher than at 800 MHz. In order to increase the RF sensitivity of the uplink, an LNA is mounted at the mast-head.

The mast-head equipment consists of an LNA, a receive filter (RXBP), and in some configurations also a duplex filter. The equipment mounted at the mast-head is optional. If the mast-head LNA is excluded, the filters will be placed in the base station.

To get full radio performance, the attenuation from the output of the LNA to the input of the multicoupler has to be 6 dB. If the feeder loss is less than 6 dB, an attenuator with appropriate loss has to be inserted.

4.5 SUPPORT PART

The support part provides power supply to the base station.

The base station is prepared for external and internal power supply. In RBS 884-1900, the support part consists of a passive power distribution network (POWD). There is an external system for power supply containing AC/DC converters and a battery backup. The external power supply is not controlled by the EMRPS.

All the cabinets except the TCB, have a duplicated DC supply. In the TCB, there is one single DC supply per two 30 W TRXs. The DC voltage is +24 V. The LNAs are DC supplied (+15 V) from the ANPC via the RX feeders.

Reference [4] contains more information on the support part.

Uppgjord - Prepared ERA/AR/SL KSN	Faktaansvarig - Subject responsible	Nr - No 28/1551-ANT 244 01 Uen
Dokansv/Godk - Doc respons/Approved ERA/AR/SLC (L-O Sundell)	Kontr - Checked	Datum - Date 1996-03-29
		Rev A
		File

- 4.6 BUILDING PRACTICE
 - Building practice BYB 401 001
 - Size of cabinet 400*600*400 mm (height*width*depth)
Maximum 5 cabinets can be piled on top of one another.
 - Size of subrack 19"
 - Size of board K2 (CRI)
Double Euro Size (TCB, ATCC, ANPC)
 - Size of LNA box 260*160*90 mm
 - Weight of cabinet
 - CRI 35 kg
 - TCB 55 kg
 - ATCC 45 kg
 - ANPC1 30 kg
 - ANPC2 35 kg
 - DC/DC 35 kg
 - Weight of cables 50 kg (3-sector site, 8 TRXs/cell)

5 INTERFACES

5.1 EXTERNAL BS INTERFACES

5.1.1 Radio

Antenna interface, reference [15].

External AFS, reference [16].

5.1.2 Transmission

T1, 1.544 Mbit/s PCM, reference [17].

E1, 2.048 Mbit/s PCM, reference [18].

5.1.3 Power Supply

DC supply and battery backup, reference [19].

5.1.4 Alarm

External alarms and external control, reference [20].

Uppgjord - Prepared ERA/AR/SL KSN	Faktaansvarig - Subject responsible	Nr - No 28/1551-ANT 244 01 Uen		
Dokansv/Godk - Doc respons/Approved ERA/AR/SLC (L-O Sundell)	Kontr - Checked	Datum - Date 1996-03-29	Rev A	File

- 5.1.5 Operator Interface
V24 terminal interface, reference [21].
- 5.2 INTERNAL BS INTERFACES
- 5.2.1 Data
CLINK layer 1, reference [22].
CLINK layer 2-6, reference [23].
TLINK, reference [24].
TRAB-TRX, reference [25].
- 5.2.2 Radio
Carrier frequency reference (TIM-NTSW-RTT),
reference [26].
Internal AFS (TIM-TRX), reference [16].
RF interface TCB-ATCC, TCB-ANPC, reference [28].
- 5.2.3 Power Supply
DC distribution, reference [27].
- 5.2.4 Alarm
Internal alarms (COP, MOP, ANP), reference [1]-[3].

Uppgjord - Prepared ERA/AR/SL KSN	Faktaansvarig - Subject responsible	Nr - No 28/1551-ANT 244 01 Uen
Dokansv/Godk - Doc respons/Approved ERA/AR/SLC (L-O Sundell)	Kontr - Checked	Datum - Date 1996-03-29
		Rev A
		File

Figure 8. Control and timing interfaces.

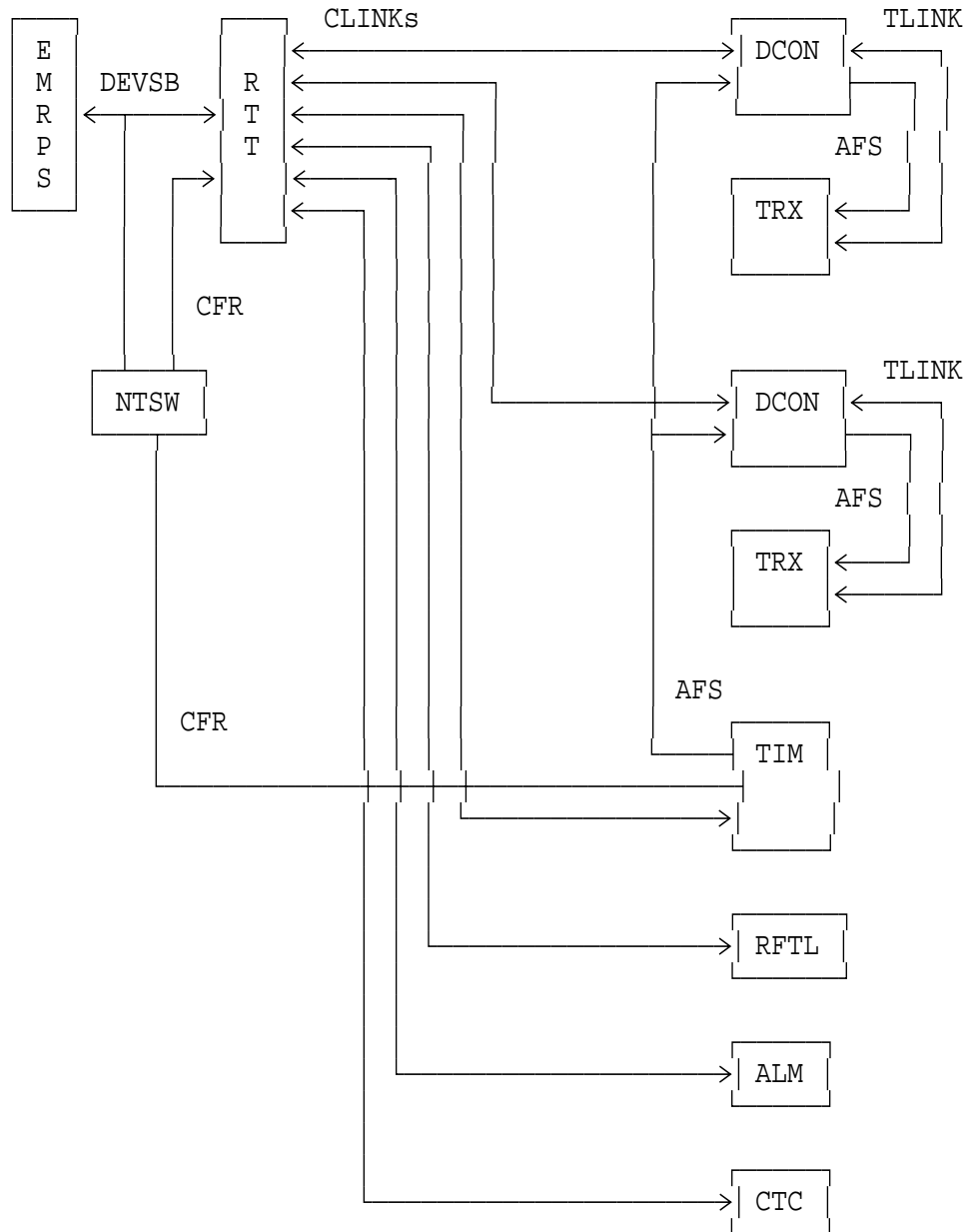

Uppgjord - Prepared ERA/AR/SL KSN	Faktaansvarig - Subject responsible	Nr - No 28/1551-ANT 244 01 Uen	
Dokansv/Godk - Doc respons/Approved ERA/AR/SLC (L-O Sundell)	Kontr - Checked	Datum - Date 1996-03-29	Rev A File

6 PERFORMANCE

6.1 RADIO NETWORK CHARACTERISTICS

The cell plan 7/21 is supported.

The maximum number of carriers that can be combined to the same antenna is 16. If 17-32 carriers are needed, two antennas have to be used.

The channel spacing for the carriers connected to the same antenna is 630 kHz. When there are two TX antennas, the channels could be interleaved between the antennas. In that way, the channel spacing within the cell would be 300 or 330 kHz. Presently, there is no software support for "interleaved channels" together with adaptive channel allocation.

6.2 RADIO PERFORMANCE

TX and RX performance of the base station, reference [29].

Performance of the BS detectors, reference [11].

Carrier frequency stabilization, reference [7].

6.3 ENVIRONMENTAL CHARACTERISTICS

EMC, reference [30].

Climate and mechanics, reference [31].

Product safety, reference [32].

6.4 TRANSMISSION PERFORMANCE

Jitter, wander etc, reference [7].

Round trip delay in MBS (downlink TRAB-TRX, uplink TRX-TRAB), reference [7].

Uppgjord - Prepared ERA/AR/SL KSN	Faktaansvarig - Subject responsible	Nr - No 28/1551-ANT 244 01 Uen
Dokansv/Godk - Doc respons/Approved ERA/AR/SLC (L-O Sundell)	Kontr - Checked	Datum - Date 1996-03-29
		Rev A
		File

6.5 POWER CONSUMPTION

Cabinet	Power consumption
CRI	145 W
TCB (30 W TRX, 8 TRXs)	1740 W
ATCC	60 W
ANPC1	125 W
ANPC2	150 W
Mast mounted LNA	5 W

6.6 TRAFFIC CAPACITY

12 DTC/EMRPS
 [1 DCCH + 8 DTC]/EMRPS
 1 DVER requires a capacity corresponding 1-2 DTC.

7 FUNCTIONS

7.1 TRAFFIC

D-AMPS 1900 is an all digital system. There are three different channel functions: DTC, DCCH, and DVER. These functions work in the same way as in the 800 MHz D-AMPS system.

The digital channel functions are described in reference [14].

7.2 OPERATION AND MAINTENANCE

The operation and maintenance functions of D-AMPS 1900 are the same as the ones for the 800 MHz system. The descriptions of the O&M functions can be found in the following references: [5], [6], [8]-[10], [12], [13].

The TX antenna is supervised by measuring the return loss. An alarm is issued if the measured value is out of range. When a duplex filter is used, the return loss cannot be measured since the duplex filter is placed between the measurement point (MCU) and the

Uppgjord - Prepared ERA/AR/SL KSN	Faktaansvarig - Subject responsible	Nr - No 28/1551-ANT 244 01 Uen	
Dokansv/Godk - Doc respons/Approved ERA/AR/SLC (L-O Sundell)	Kontr - Checked	Datum - Date 1996-03-29	Rev A File

antenna (figures 3, 5, 7). In that case it is only the diversity supervision of the TX/RX antennas that will detect if the antennas are faulty.

All the cabinets have an identity switch (CID) showing the cabinet address (position). The boards that have a device processor can read the CID. On the front of the boards there are a number of indicators (power, error, status). The numbering of the cabinets as well as the logical functions of the indicators are defined in reference [33].

8

PLACING OF CABINETS

In order to get the best possible RF performance, the cabinets should be placed as shown in figure 9. The basic configuration is a three-sector site with 8 TRXs per cell. It is also shown how this site can be extended to 16 TRXs per cell.

The maximum number of TRXs per cell is 32. Figure 10 shows a site with 3*32 TRXs. The following cabinets have to be added to a 3*16 site to get a 3*32 site: 6 TCBs, 3 ATCC1s, 3 ATCC2s, 2 CRIs, and 1 POWD.

Figure 9. Placing of cabinets in a 3-sector site.

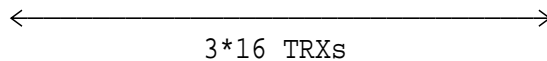
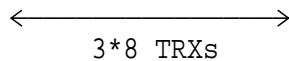
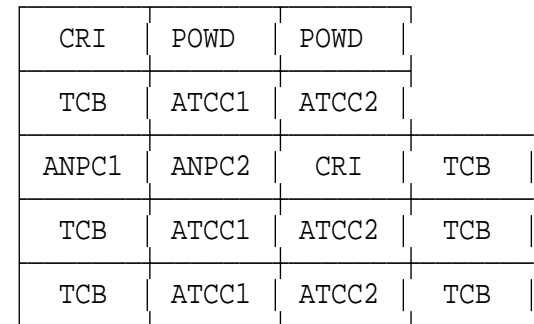

8 TRXs → 20 DTC, 1 DCCH, 1 DVER

Uppgjord - Prepared ERA/AR/SL KSN	Faktaansvarig - Subject responsible	Nr - No 28/1551-ANT 244 01 Uen
Dokansv/Godk - Doc respons/Approved ERA/AR/SLC (L-O Sundell)	Kontr - Checked	Datum - Date 1996-03-29
		Rev A
		File

Figure 10. 3-sector site (32 TRXs/cell).

CRI	POWD	POWD	POWD					
TCB	ATCC1	ATCC2	CRI	CRI				
ANPC1	ANPC2	CRI	TCB	TCB	ATCC1	ATCC2	TCB	
TCB	ATCC1	ATCC2	TCB	TCB	ATCC1	ATCC2	TCB	
TCB	ATCC1	ATCC2	TCB	TCB	ATCC1	ATCC2	TCB	

9 CO-SITING

The base stations RBS 884-1900 and RBS 884 can be connected to the same EMG, i.e. they can have a common CRI. The prerequisite is that the stability of the carrier frequency reference meets the requirement for D-AMPS 1900.

10 TERMINOLOGY

- AFS air frame synchronization
- ALM alarm module
- ANP antenna near part
- ANPC ANP complementary equipment cabinet
- ATC autotuned combiner
- ATCC ATC and CTC cabinet
- BER bit error rate
- BS base station
- CFR carrier frequency reference
- CID cabinet identity
- CLINK communication link
- COP control part
- CRI control and radio interface
- CTC combiner tuning controller
- CW continuous wave
- DCCH digital control channel
- DCON data connection board
- DEVCB device control bus
- DEVSB device speech bus
- DPX duplex filter
- DPXC duplex filter cabinet
- DTC digital traffic channel
- DVER digital verification
- EMC electro magnetic compatibility
- EMG extension module group
- EMRP extension module regional processor

Uppgjord - Prepared ERA/AR/SL KSN	Faktaansvarig - Subject responsible	Nr - No 28/1551-ANT 244 01 Uen
Dokansv/Godk - Doc respons/Approved ERA/AR/SLC (L-O Sundell)	Kontr - Checked	Datum - Date 1996-03-29
		Rev A
		File

EMRPB	EMRP bus
EMRPS	EMRP with speech bus interface
ETB	exchange terminal board
ETC	exchange terminal circuit
FER	frame erasure rate
GS	group switch
LNA	low noise amplifier
MBS	mobile telephony base station subsystem
MCA	multicoupler branch A
MCB	multicoupler branch B
MCU	measuring coupler unit
MOP	modem part
MSC	mobile services switching centre
NTSW	node time switch
PCM	pulse code modulation
PFCON	power and fan connection board
POC	power connection board
POWD	power distribution
PSP	power splitter
PSTN	public switching telephone network
RF	radio frequency
RFTL	radio frequency test loop
RSSI	received signal strength indicator
RTT	radio transceiver terminal
RX	receiver
RXBP	receiver bandpass filter
STR	signalling terminal regional
SUP	support part
TCB	transceiver cabinet
TDMA	time division multiple access
TIM	timing module
TLINK	CLINK with TTL interface
TRAB	transcoder board
TRX	transceiver
TX	transmitter
TXBP	transmitter bandpass filter
T1	The American standard for 1.544 Mbit/s PCM, 24 channels numbered 1-24, 64 kbit/s per channel.
E1	The European standard for 2.048 Mbit/s PCM, 32 channels numbered 0-31, 64 kbit/s per channel.

 11 REFERENCES

- [1] Control Part, 1551-COA 109 294.
- [2] Modem Part, 1551-COA 109 295.
- [3] Antenna Near Part, 1551-COA 109 296.
- [4] Support Part, 1551-COA 109 298.

Uppgjord - Prepared ERA/AR/SL KSN	Faktaansvarig - Subject responsible	Nr - No 28/1551-ANT 244 01 Uen	
Dokansv/Godk - Doc respons/Approved ERA/AR/SLC (L-O Sundell)	Kontr - Checked	Datum - Date 1996-03-29	Rev A File

- [5] Program Loading, 110/155 16-ANT 244 01.
- [6] Channel Equipment Coordination and Administration, 111/155 16-ANT 244 01.
- [7] Synchronization and Carrier Frequency Stabilization, 112/155 16-ANT 244 01.
- [8] Supervision and Fault Handling, 113/155 16-ANT 244 01.
- [9] Blocking Control, 114/155 16-ANT 244 01.
- [10] Start and Restart, 115/155 16-ANT 244 01.
- [11] BS Detectors, 116/155 16-ANT 244 01.
- [12] Test in MBS, 119/155 16-ANT 244 01.
- [13] Voice Path and Transmission Line Coordination and Administration, 121/155 16-ANT 244 01.
- [14] Digital Traffic Control, 123/155 16-ANT 244 01.
- [15] Interface of Antenna System, 4/155 19-ANT 244 01.
- [16] Airframe Time Reference in RBS 884, 85/155 19-ANT 244 01.
- [17] Interface to Transmission Network, MSC-BS and BS-BS, 1544 kbit/s, 31/155 19-ANT 244 01.
- [18] Interface to Transmission Network, MSC-BS and BS-BS, 2048 kbit/s, 77/155 19-ANT 244 01.
- [19] DC Supply to RBS 884, 86/155 19-ANT 244 01.
- [20] External Alarms and External Control in RBS 884, 47/155 19-ANT 244 01.
- [21] CRI/V24 Terminal Interface, 48/155 19-ANT 244 01.
- [22] CLINK Layer 1, 26/155 19-ANT 244 01.
- [23] CLINK Layer 2-6, 27/155 19-ANT 244 01.
- [24] TLINK Concept in RBS 884M/RBS 884C, 56/155 19-ANT 244 01.
- [25] TRAB-TRX, 74/155 19-ANT 244 01.
- [26] Carrier Frequency Reference, 88/155 19-ANT 244 01.

Uppgjord - Prepared ERA/AR/SL KSN	Faktaansvarig - Subject responsible	Nr - No 28/1551-ANT 244 01 Uen	
Dokansv/Godk - Doc respons/Approved ERA/AR/SLC (L-O Sundell)	Kontr - Checked	Datum - Date 1996-03-29	Rev A File

- [27] Power Distribution in RBS 884,
29/155 19-ANT 244 01.
- [28] RBS 884-1900 Radio Performance Verification
of ANPC, ATCC and TCB, 2/1551-HRB 104 44.
- [29] Radio Performance RBS 884-1900,
73/155 17-ANT 244 01.
- [30] EMC, 1/155 02-HRB 104 44.
- [31] Climate and Mechanics, 2/155 02-HRB 104 44.
- [32] Product Safety, 3/155 02-HRB 104 44.
- [33] Product Characteristics, 10/102 60-ANT 244 01.

12

REVISION INFORMATION

Revision Comments