

Exhibit 8 Manual

Prepared (also subject responsible if other) / XSNJOER		No. 174/1551-LZA 701 0001 Uen		
Approved EAB/ FJG/YP (Louise Cederlund)	Checked	Date 2007-06-12	Rev A	Reference

RBS Product Description

RBS 2207

Copyright

© Copyright Ericsson 2005, 2007. All rights reserved.

Disclaimer

No part of this document may be reproduced in any form without the written permission of the copyright owner.

The contents of this document are subject to revision without notice due to continued progress in methodology, design and manufacturing. Ericsson shall have no liability for any error or damage of any kind resulting from the use of this document.

Contents		Page
1	RBS 2207 Product Description	3
2	Product Overview	3
2.1	Main Features	3
2.2	Variants	4
2.3	Optional Equipment	4
3	Dimensions	5
4	Space Requirements	5
5	Environment	8
5.1	Operating Environment	8
5.2	Environmental Impact	9
5.3	Compliance Distances for Electromagnetic Exposure	9
5.4	Materials	12
6	Hardware Units	12
6.1	Standard Hardware Units	13
6.2	Optional Hardware Units	15
7	Interfaces	15
7.1	External Connections	17
7.2	Test Interface	18
7.3	Operator Interface	18

Prepared (also subject responsible if other) / XSNJOER		No. 174/1551-LZA 701 0001 Uen		
Approved EAB/ FJG/YP (Louise Cederlund)	Checked	Date 2007-06-12	Rev A	Reference

8	Power System	19
8.1	AC mains supply voltage	19
8.2	+24 V DC Supply Voltage	20
8.3	–48 to –60 V DC Supply Voltage	21
8.4	Battery Backup	21
8.5	Power Consumption	22
9	Transmission	22
10	Alarms	23
11	Standards, Regulations and Dependability	23
11.1	Safety Standards	23
11.2	Other Standards and Regulations	23

Prepared (also subject responsible if other) / XSNJOER		No. 174/1551-LZA 701 0001 Uen		
Approved EAB/ FJG/YP (Louise Cederlund)	Checked	Date 2007-06-12	Rev A	Reference

1 RBS 2207 Product Description

The RBS 2207, a member of the RBS 2000 family, is a 6-TRX radio base station for indoor applications. This cabinet covers the same floor area as the RBS 2202 and RBS 2206, but the cabinet height is lower.

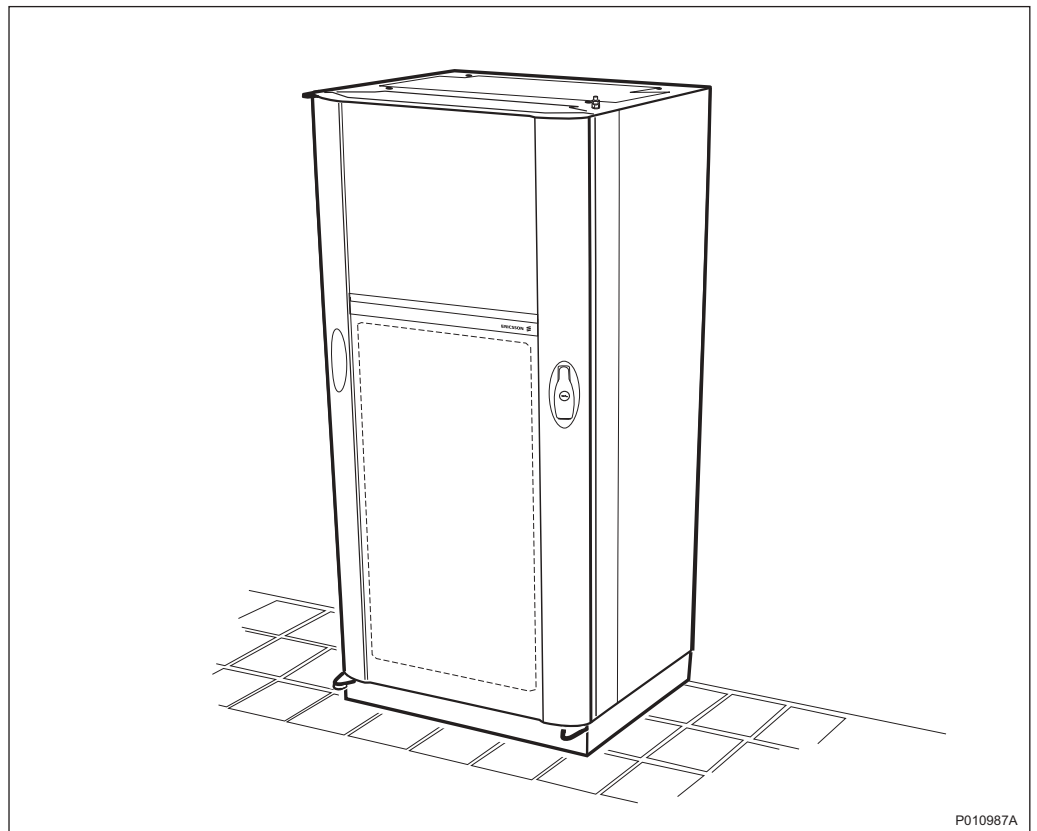

2 Product Overview

The RBS 2207 is a medium capacity indoor base station. It is used for indoor applications, with up to three double Transceiver Units (dTRU). The RBS 2207 is designed to be transported as a fully-assembled cabinet to the site. All interior units are easily accessible from the front of the cabinet, which means that the cabinets can be mounted side by side with their backs against a wall.

2.1 Main Features

The RBS 2207 can support the following features:

- 1, 2 or 3 sectors in one cabinet using CDU-G and/or CDU-J

Prepared (also subject responsible if other) / XSNJOER		No. 174/1551-LZA 701 0001 Uen		
Approved EAB/ FJG/YP (Louise Cederlund)	Checked	Date 2007-06-12	Rev A	Reference

- Discontinuous transmission/reception
- Duplex filters
- Dynamic power regulation
- Encryption/ciphering
- EDGE
- Expansion by Transceiver Group (TG) synchronization
- External alarms
- Frequency hopping
- Global positioning system (GPS) synchronization
- Radio configurations supported on 800, 900, 1800 and 1900 MHz
- Receiver diversity
- Transmission Interface: The following transport network interface alternatives exist:
 - T1 1.5 Mbit/s, 100 Ω , with internal synchronization
 - E1 2 Mbit/s, 75 Ω , with PCM synchronization
 - E1 2 Mbit/s, 120 Ω , with PCM synchronization
- Wide range power input 120–250 V AC
- Wide range power input –48 to –60 V DC

2.2 Variants

There are three RBS 2207 cabinet versions:

- –48 to –60 V DC
- 120–250 V AC, 50 to 60 Hz, +24 V DC, with optional battery backup
- +24 V DC (without PSUs)

2.3 Optional Equipment

The equipment listed below is available, but is not necessary for basic functionality.

- Battery backup (in a separate cabinet)
- Bias injectors

Prepared (also subject responsible if other) / XSNJOER		No. 174/1551-LZA 701 0001 Uen		
Approved EAB/ FJG/YP (Louise Cederlund)	Checked	Date 2007-06-12	Rev A	Reference

- Dual duplex Tower Mounted Amplifier (ddTMA)
- External synchronization bus (ESB)
- Distribution Frame (DF) with OVP
- TMA-CM
- Transmission Adapter (TA)
- GPS receiver
- RX-Splitter 01

3 Dimensions

The following section describes the measurements of the RBS 2207.

Table 1 Weight

Unit	Weight
RBS cabinet (fully equipped including base frame)	180 kg (397 lbs.)
Base frame	8 kg (18 lbs.)

Table 2 Color

Color	Reference No.
Grey	NCS 1002-R

4 Space Requirements

The following sections indicate the required space and recommended floor layout.

Prepared (also subject responsible if other) / XSNJOER		No. 174/1551-LZA 701 0001 Uen		
Approved EAB/ FJG/YP (Louise Cederlund)	Checked	Date 2007-06-12	Rev A	Reference

Free Space above the RBS Cabinet

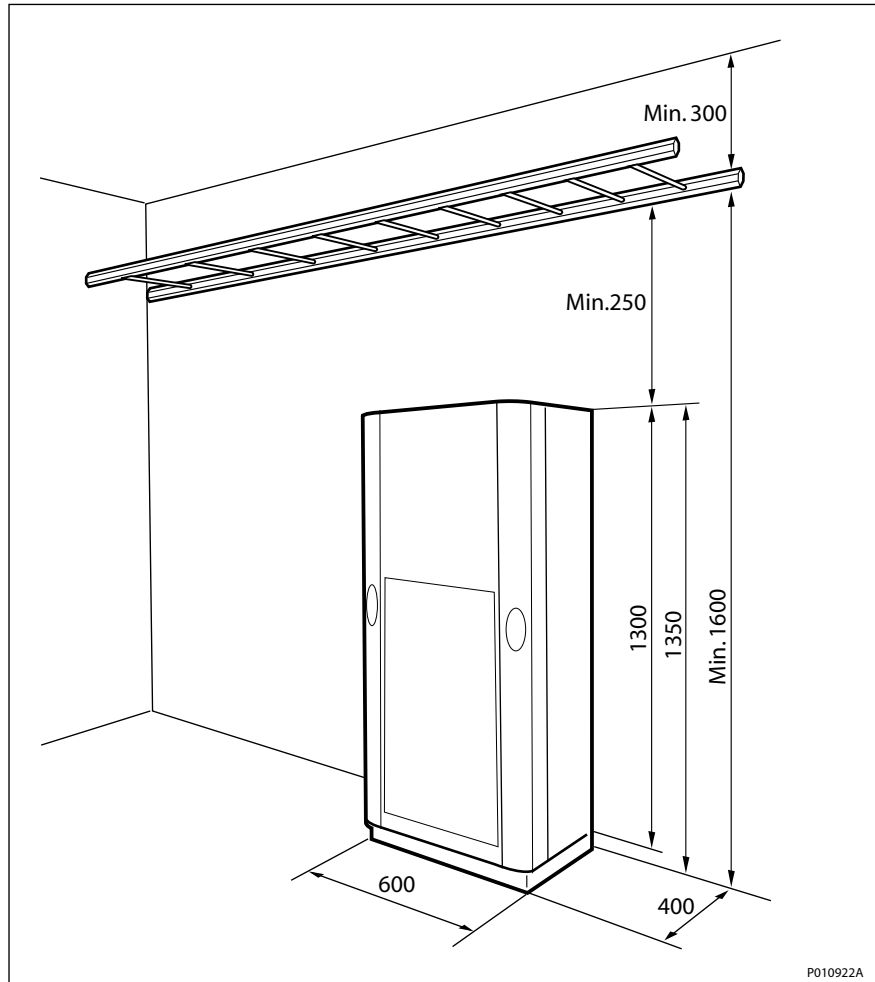

Figure 1 RBS 2207, Free Space Above the Cabinet

The recommended distance between the cabinet and cable ladder is 250 mm. A shorter distance makes it difficult to exchange fans and may restrict the air flow. A space of 300 mm is recommended above the cable ladder, in order to simplify the cable installation work.

The door projects 70 mm in front of the cabinet.

Prepared (also subject responsible if other) / XSNJOER		No. 174/1551-LZA 701 0001 Uen		
Approved EAB/ FJG/YP (Louise Cederlund)	Checked	Date 2007-06-12	Rev A	Reference

Layout for RBS Cabinets

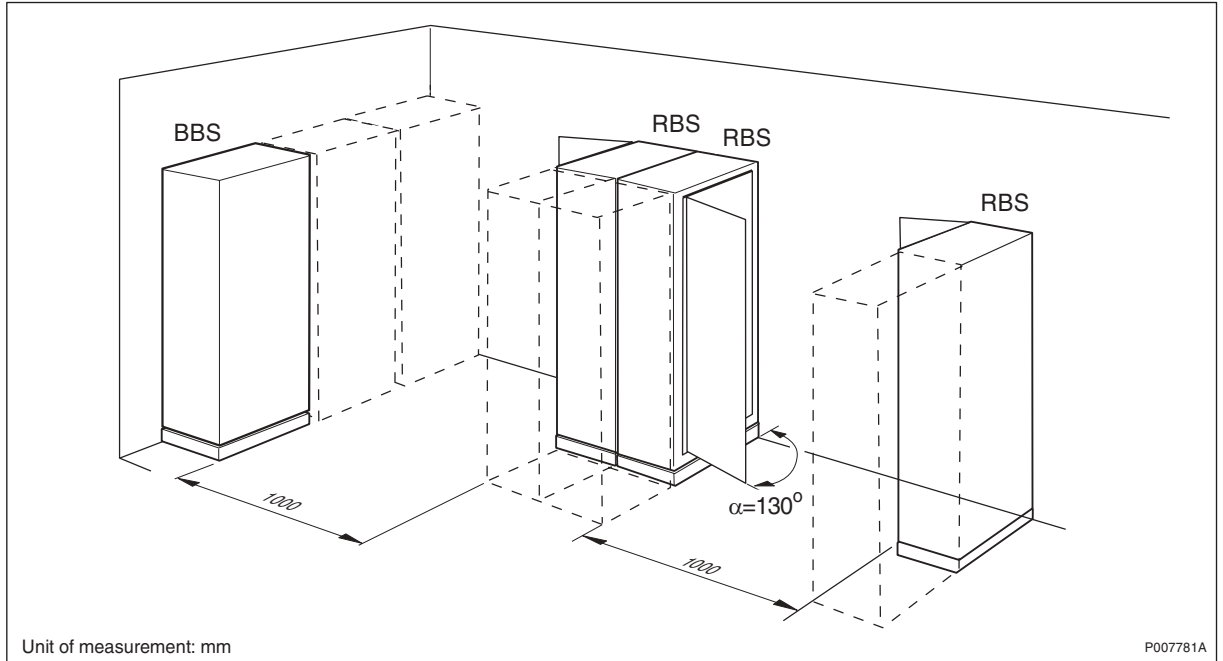

Figure 2 Floor Layout and Space Requirements

The RBS cabinets and battery backup system (BBS) racks are mounted on the floor, and may be positioned against a wall, back to back, or free standing without contact with other cabinets.

Additional cabinets and racks can be positioned to the left or right of the first installed cabinet. However, expansion to the right is recommended in order to follow the same global standard.

A distance of 1000 mm in front of the cabinets and racks for maintenance work is recommended.

Note: Space for future expansion must be considered as indicated in the dotted line in the figure above.

Earthquake Requirements

If the RBS cabinet is to fulfill the requirements for earthquake protection, the space between wall and cabinet is to be at least 100 mm and between cabinets at least 150 mm.

Prepared (also subject responsible if other) / XSNJOER		No. 174/1551-LZA 701 0001 Uen		
Approved EAB/ FJG/YP (Louise Cederlund)	Checked	Date 2007-06-12	Rev A	Reference

Footprint

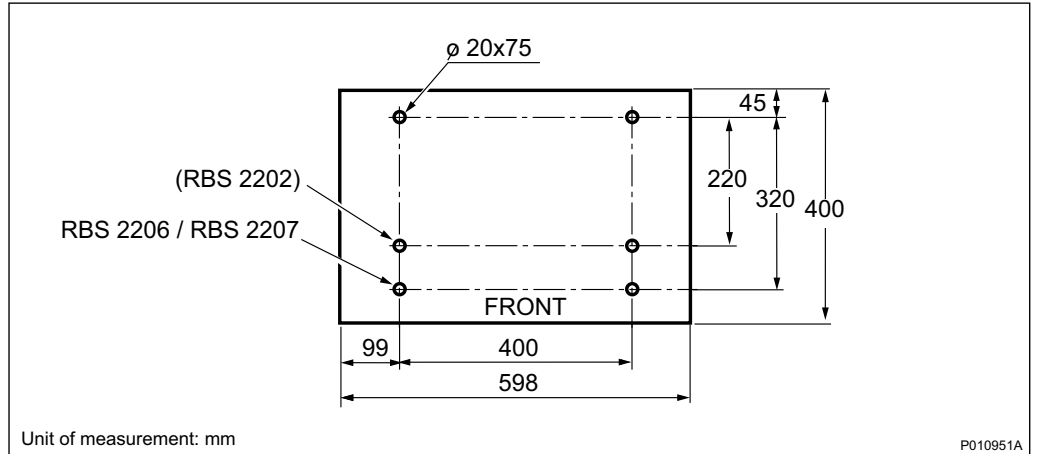

Figure 3 Hole Pattern Overview

The RBS 2207 has the same footprint as the RBS 2202 and 2206 cabinets. The base frame can be used as a template to mark new holes. If an RBS 2202 or an RBS 2206 is being replaced by an RBS 2207, the holes for the old cabinet can be used for the new cabinet.

5 Environment

The RBS 2207 is designed to operate within limits stated for climatic requirements, and also to have a limited effect on the environment.

5.1 Operating Environment

The climatic requirements the RBS 2207 has on the site are shown in the table below.

Table 3 Environmental Specifications

Environmental Parameters	Normal Operation ⁽¹⁾	Safe Function	Non-destructive Conditions ⁽²⁾
Temperature	+5 to +40 C°	0 to +45 C°	-10 to +55 C°
Relative Humidity	5–85%	5–90%	5–90%

Prepared (also subject responsible if other) / XSNJOER		No. 174/1551-LZA 701 0001 Uen		
Approved EAB/ FJG/YP (Louise Cederlund)	Checked	Date 2007-06-12	Rev A	Reference

- (1) Normal operation describes the environmental conditions where all units function as specified.
- (2) Non-destructive conditions describe environmental stress above the limits for normal conditions with no function guaranteed and unspecified degradation. When the environmental stress has dropped to normal conditions, restoring full RBS performance requires no manual intervention on site. Non-destructive conditions refer to a maximum period of 96 consecutive hours, and a maximum total of 5.5 days in a three-year period.

Ground Vibrations

The RBS 2207 is tested to withstand random vibrations of up to 0.2 m/s². It is also tested for single shocks up to 40 m/s². The cabinet is tested for seismic exposure with a test frequency of 1–35 Hz. Maximum test level of the Required Response Spectrum (RRS) is 50 m/s² within 2–5 Hz. The shape of RRS is defined by the ETSI standard.

Levelling

For cabinet levelling purposes, the floor must be level to within ±3 mm/2000 mm and the floor gradient be within ±0.1°.

5.2 Environmental Impact

This section describes the effect that the cabinet has on the environment.

Heat Dissipation

The RBS 2207 generates an average heat load of 1000 W. The exact figure is dependent upon configuration, equipment and site-specific conditions.

5.3 Compliance Distances for Electromagnetic Exposure

The compliance distance is the minimum separation that should be kept between an antenna and a person in order to ensure that ICNIRP RF exposure limits are not exceeded.

Note: ICNIRP, "Guidelines for limiting exposure to time-varying electric, magnetic, and electromagnetic fields (up to 300 GHz)", International Commission on Non-Ionizing Radiation Protection, Health Physics, vol. 74, no. 4, 1998.

Ericsson has performed a free-space near-field RF exposure assessment of typical configurations of RBS 2207 with a recommended antenna. The resulting dimensions, in metre, for a compliance boundary for both public and occupational exposure are shown in Table 4.

The compliance boundary is defined as a cylinder around the antenna, see figure below. The antenna is not located at the centre of the cylinder. Instead it is located almost at the edge, facing towards the centre of the cylinder. The distance between the antenna's rear and the edge of the cylinder is the "Distance behind antenna". The height of the cylinder is the antenna height

Prepared (also subject responsible if other) / XSNJOER		No. 174/1551-LZA 701 0001 Uen		
Approved EAB/ FJG/YP (Louise Cederlund)	Checked	Date 2007-06-12	Rev A	Reference

plus equal distances above and below the antenna. The cylinder shape overestimates the compliance distances right beside the antenna.

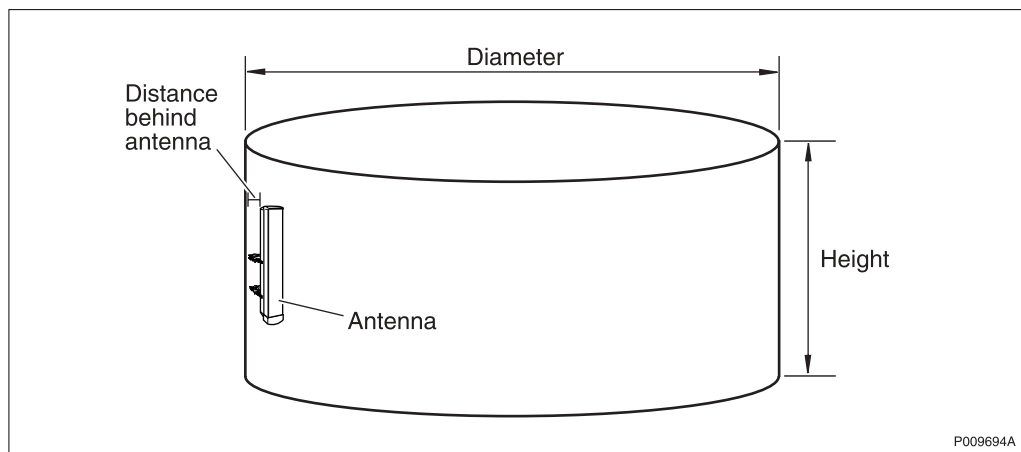

Figure 4 Compliance Boundary Cylinder

Note: Table 4 shows an example for a typical antenna. As the antenna field distributions will differ, complete calculations or measurements may be necessary in order to establish the compliance boundary for other configurations chosen by the customer. For further information on calculation methods, see document *Radio Frequency Electromagnetic Fields Safety Instructions*, EN/LZT 720 0399.

Prepared (also subject responsible if other) / XSNJOER		No. 174/1551-LZA 701 0001 Uen		
Approved EAB/ FJG/YP (Louise Cederlund)	Checked	Date 2007-06-12	Rev A	Reference

Table 4 Compliance Boundary Dimensions for the General Public (GP) and Occupational (O) Exposure for Typical Configurations.

		Dimensions of Cylindrical Compliance Boundary in Metre (m)					
		Diameter		Height		Distance behind	
Frequency (MHz)	RBS Configuration	GP	O	GP	O	GP	O
900	3x2 uncombined	7	3	1.7	1.4	0.1	0.1
1800	3x2 uncombined	5	1	1.6	1.4	0.1	0.05
900	3x2 combined	4	1	1.5	1.4	0.1	0.1
1800	3x2 combined	2	0.5	1.4	1.4	0.1	0.05
900	3x1 comb. TCC	6	3	1.7	1.4	0.1	0.1
1800	3x1 comb. TCC	5	1	1.6	1.4	0.1	0.05

Compliance distances to the side of the antenna for occupational exposure are 0.15 m for all configurations above. For characteristics of an antenna recommended for typical configurations of an RBS 2207, see table below.

Table 5 Characteristics for a Typical Antenna (KRE 101 1916/1)

Antenna Specifications	X-pol macro RBS sector antenna
Antenna Height	1.3 m
Horizontal Half-power Beam Width	65 degrees
Vertical Half-power Beam Width	14.5 degrees at 900 MHz, 7.8 degrees at 1800 MHz
Antenna Gain	14 dBi at 900 MHz, 16.5 dBi at 1800 MHz
Downtilt	0 degrees

The maximum power fed to the antenna, as a function of the number of transceiver units (TRUs) per antenna and maximum power (including tolerances and transmission loss) per TRU, for RBS 2207, are given in table below.

Prepared (also subject responsible if other) / XSNJOER		No. 174/1551-LZA 701 0001 Uen		
Approved EAB/ FJG/YP (Louise Cederlund)	Checked	Date 2007-06-12	Rev A	Reference

Table 6 Maximum Power to Antenna for Various RBS 2207 Configurations

RBS Configurations	Frequency (MHz)	Nominal Output Power per TRU (dBm)/(W)	Maximum Power into Antenna ⁽¹⁾ (dBm)/(W)
3x2 uncombined	900	45.5/35	47.5/56.2
	1800	44.5/28	46.5/44.7
3x2 combined	900	42/16	44/25
	1800	41/13	43/20
3x1 combined	900	48/63	47/50
TCC	1800	47/50	46/40

(1) Including power tolerance level (+2dB) and transmission losses (- 3dB).

5.4 Materials

All Ericsson products fulfill the legal, market and Ericsson requirements regarding:

- Fire resistance of material, components, wires and cables
- Declaration of materials
- Use of restricted material
- Recycling

Package Material

The package material is recyclable.

6 Hardware Units

A high level of availability is achieved using strict functional modularity with a system of standardized units. A failed unit can easily be replaced by a new one.

The RBS 2207 cabinet contains the radio equipment, power supply and the climate equipment (fans). All required transmission equipment and battery backup must be housed outside the cabinet.

Outside equipment is listed under optional units. Not all HW units are covered in this section, only those directly related to the RBS.

Prepared (also subject responsible if other) / XSNJOER		No. 174/1551-LZA 701 0001 Uen		
Approved EAB/ FJG/YP (Louise Cederlund)	Checked	Date 2007-06-12	Rev A	Reference

6.1 Standard Hardware Units

This section briefly describes the standard hardware units required for functionality, irrespective of configuration or frequency.

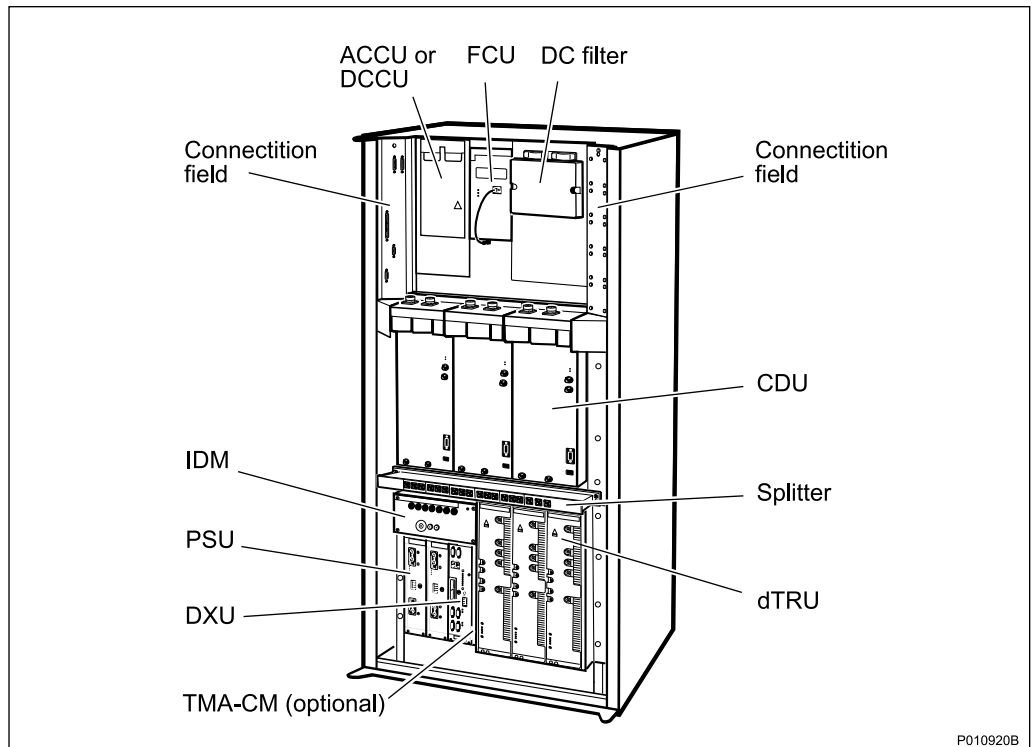

Figure 5 Standard Hardware Units

ACCU - AC Connection Unit

The ACCU distributes the incoming AC power supply voltages to the PSUs. The unit also contains AC filter equipment.

Number of units: 0–1

CDU - Combining and Distribution Unit

The CDU is the interface between the transceivers and the antenna system. All signals are filtered before transmission, and after reception, by means of bandpass filters. The CDU allows several dTRUs to share antennas. There is a maximum of three CDUs in one RBS 2207.

The CDU distributes the received signal to several transceivers. The CDU supports EDGE. Both CDU-G and CDU-J is used in the RBS 2207. CDU-G and CDU-J can be configured either for high capacity or for high coverage. It is a combiner that can be used for synthesizer hopping. To achieve capacity, the

Prepared (also subject responsible if other) / XSNJOER		No. 174/1551-LZA 701 0001 Uen		
Approved EAB/ FJG/YP (Louise Cederlund)	Checked	Date 2007-06-12	Rev A	Reference

CDU uses the hybrid combiner in the dTRU. To achieve coverage, the CDU is used in a configuration when the hybrid combiner in the dTRU is not used.

Number of units: 1–3

DCCU - DC Connection Unit

The DCCU distributes the incoming DC power supply voltages to the PSUs. The unit also contains DC filter equipment.

Number of units: 0–1

dTRU - double Transceiver Unit

The dTRU contains two TRXs for transmission and reception of two radio carriers. It has a built-in combiner with the optional possibility of combining two TX signals into one TX output. It is also prepared for four-branch RX diversity, for further improvements in sensitivity.

Number of units: 1–3

DXU-21 - Distribution Switch Unit

The DXU is the central control unit for the RBS. It supports the interface to the BSC, and it collects and transmits alarms. The DXU controls the power and climate equipment for the RBS. It has a removable compact flashcard, which makes it possible to replace a faulty DXU without the need for loading RBS software from the BSC. It can handle both 2 Mbit (E1) and 1.5 Mbit (T1) PCM links.

Number of units: 1

FCU - Fan Control Unit

The FCU controls the four fans in the cooling system by regulating fan speed. The FCU is controlled by the DXU.

Number of units: 1

IDM-02 - Internal Distribution Module

The IDM contains circuit breakers for distribution of the internal +24 V DC power to the various units.

Number of units: 1

PSU - Power Supply Units

The PSUs are available in two versions, PSU AC for connection to AC mains, or PSU DC for connection to –48 to –60 V DC power supply. The PSU AC converts 120–250 V to regulated +24 V DC. The PSU DC converts –48 to –60 V DC to regulated +24 V DC.

Number of units: 0–2

Prepared (also subject responsible if other) / XSNJOER		No. 174/1551-LZA 701 0001 Uen		
Approved EAB/ FJG/YP (Louise Cederlund)	Checked	Date 2007-06-12	Rev A	Reference

DC Filter

The DC filter unit is the interface for +24 V DC power supply or battery backup.

Number of units: 0–1

6.2 Optional Hardware Units

This section describes the optional RBS 2207 hardware units.

Bias injector

The bias injector is used to provide the ddTMA with DC power, from the TMA-CM, over the RX/TX feeder cables. Six bias injectors can be connected to one TMA-CM. The BIAS-IC is mounted outside the cabinet, as close to the RF output as possible.

Number of units: 0–6

BBS

The RBS 2207 can be provided with battery backup from an external cabinet, either a BBS 2000 or a BBS 2202 equipped with BFU-21 or BFU-22.

ddTMA - dual duplex Tower Mounted Amplifier

The ddTMA is to be mast-mounted and placed close to the antenna. It improves the receiver sensitivity. The ddTMA saves feeder cables by duplexing RX and TX signals to the same cable.

Number of units: 0–6

TMA-CM - Tower Mounted Amplifier - Control Module

The Control Module is used to provide up to six ddTMAs with 15 V DC power through the bias injector. It is also used to identify TMA faults and forward this information to the alarm module in the RBS.

Number of units per cabinet: 0–1

RX-Splitter 01

RX-Splitter 01 distributes the receiver signals from the CDUs to the dTRU in specific configurations of the RBS.

Number of units per cabinet: 0–1

7 Interfaces

In this section all external and internal connections are listed, as well as the test interface and the operator interface.

Prepared (also subject responsible if other) / XSNJOER		No. 174/1551-LZA 701 0001 Uen		
Approved EAB/ FJG/YP (Louise Cederlund)	Checked	Date 2007-06-12	Rev A	Reference

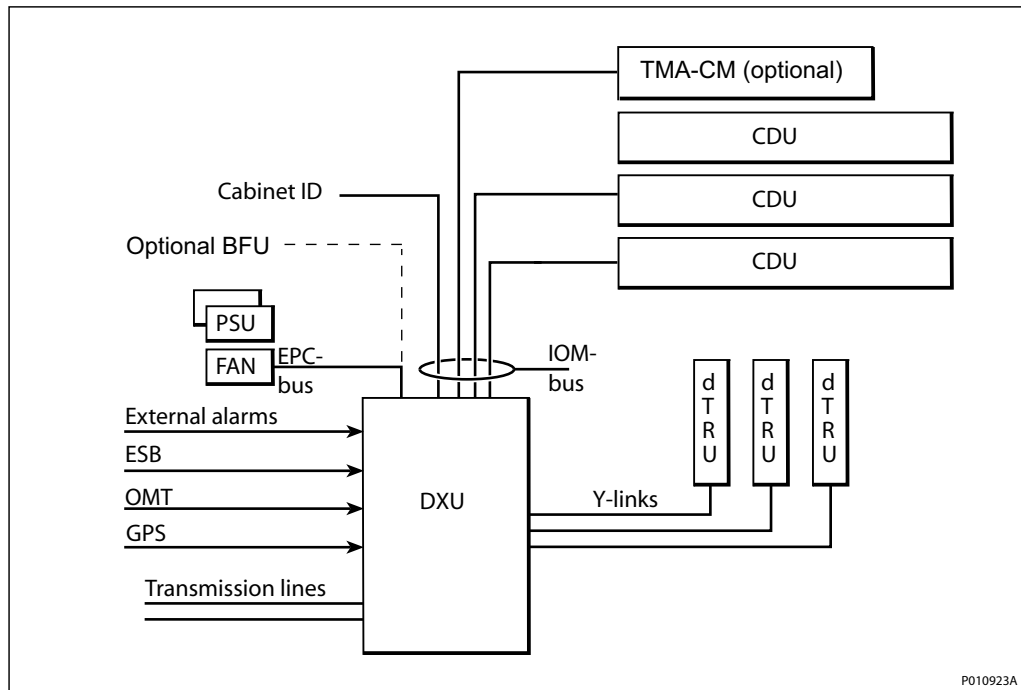

Figure 6 Block Diagram Showing Internal Power and Signal Paths

The connection field for external connectors is located at the top of the radio cabinet inside the door. Internal connections, the test interface and operator interface are located on some hardware units.

Prepared (also subject responsible if other) / XSNJOER		No. 174/1551-LZA 701 0001 Uen		
Approved EAB/ FJG/YP (Louise Cederlund)	Checked	Date 2007-06-12	Rev A	Reference

7.1 External Connections

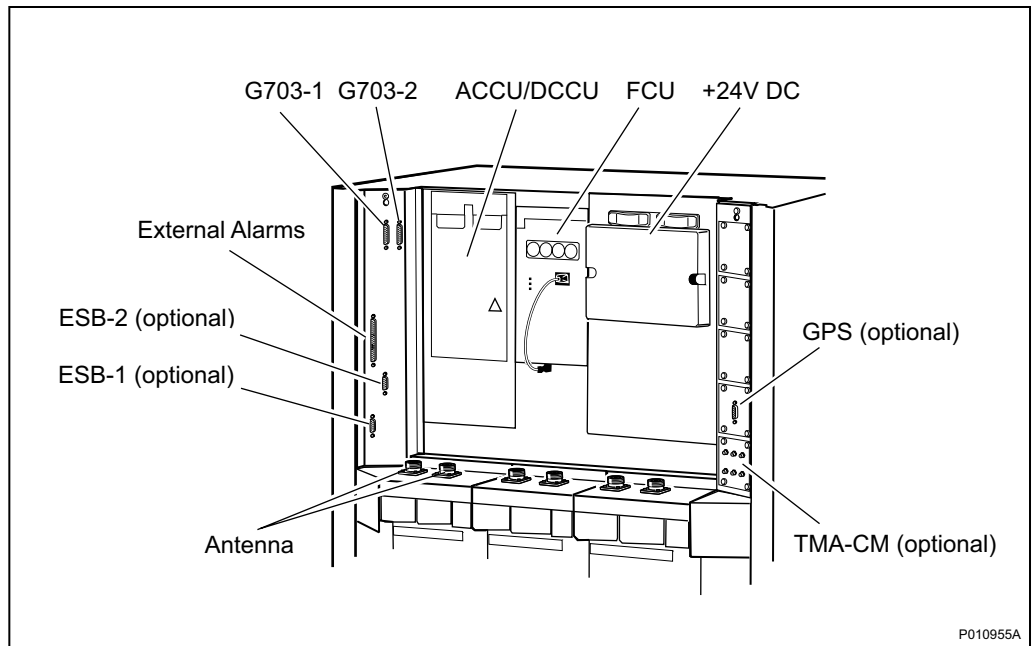

Figure 7 External Connectors

Antenna feeders are directly connected to the CDUs. If bias injectors are used, they are connected directly to the CDU and the antenna feeder is connected to the bias injector.

Table 7 External Connections

Connection Name	Description	Connector Type
CDU	Feeder (and bias injector) connection to antennas	7-16 female connector
G.703-1	Transmission Link 1	15-pin female, D-sub
G.703-2	Transmission Link 2	15-pin female, D-sub
External Alarms	External alarm inputs to DF	37-pin female, D-sub
ESB-1	ESB to co-sited cabinets	9-pin female, D-sub
ESB-2	ESB to co-sited cabinets	9-pin female, D-sub
FCU RD	Optical cable connector from the BBS	Opto connector
FCU TD	Optical cable connector to the BBS	Opto connector

Prepared (also subject responsible if other) / XSNJOER		No. 174/1551-LZA 701 0001 Uen		
Approved EAB/ FJG/YP (Louise Cederlund)	Checked	Date 2007-06-12	Rev A	Reference

Connection Name	Description	Connector Type
+24 V DC	DC filter + connection	Cable clamp
+24 V DC	DC filter - connection	Cable clamp
Earth	Earth stud M8 to main earth cable	M8 stud
ACCU 1-2	Mains connection to PSU-AC 1-2	Screw terminal
DCCU 1-2	-48 V connection to PSU-DC 1-2	Screw terminal

7.2 Test Interface

The Operation and Maintenance Tool (OMT) port is used to connect the OMT to the RBS. A remote OMT can also be used from the BSC, which sends signals over the Abis interface.

7.3 Operator Interface

The Man Machine Interface (MMI) in the RBS 2207 is based on visual indicators and buttons located on the hardware units in the cabinet.

Internal Indicators

Battery mode	Indicates that the RBS is running on battery
RBS fault	One or more faults are detected on RUs in the RBS
EPC bus fault	Indicates the state of the EPC bus
Ext alarm	One or more supervised external alarms are active
Fault	Fault detected and localized to the RU
Local mode	The RU is in local mode
Operational	The RU is operational
Test result	Indicates the result of tests
Transmission OK	Indicates state of transmission on ports A-D
RF off	RF not enabled

Buttons

dTRU reset	Resets the dTRU
DXU reset	Resets all subunits

Prepared (also subject responsible if other) / XSNJOER		No. 174/1551-LZA 701 0001 Uen		
Approved EAB/ FJG/YP (Louise Cederlund)	Checked	Date 2007-06-12	Rev A	Reference

- Local/remote mode Changes RU mode to local or remote mode
- Test call Initiates the test operation function

Barcode

The barcode for product identification is readable without disturbing the RBS function.

8 Power System

The power system of the RBS 2207 depends on the choice of power supply and may include a number of units outside the RBS.

The RBS 2207 can be connected either to AC mains supply voltage or to DC supply voltage.

Table 8 Power Supply Voltage Alternatives

Nominal Voltage	PSU
120–250 V AC, 50–60 Hz	PSU-AC
+24 V DC	PSU not needed
–48 to –60 V DC	PSU-DC

Note: It is mandatory that a readily accessible disconnect device is incorporated in the fixed wiring. The disconnect device must disconnect all live wires from the cabinet.

8.1 AC mains supply voltage

AC mains supply voltage is connected to the cabinet using two AC cables. If the power supply does not meet the AC power requirements, then filters and stabilizers must be installed to protect the equipment and ensure proper operation.

There are two ways to connect power to the RBS. They are:

- Single phase line to neutral
- Single phase line to line

Note: When single phase line to line is used, each PSU requires two circuit breakers or fuses.

Prepared (also subject responsible if other) / XSNJOER		No. 174/1551-LZA 701 0001 Uen		
Approved EAB/ FJG/YP (Louise Cederlund)	Checked	Date 2007-06-12	Rev A	Reference

Table 9 AC Mains Power Requirements

Voltage Range for Specified Performance (phase voltage)	120–250 V AC
Voltage range	90–275 V AC ⁽¹⁾
Frequency	45–65 Hz
Inrush current, max.	30 A (1–30 ms)
Maximum AC power	1.4 kW x 2
Non-destructive range	0–275 V AC
Oversvoltage <20 ms	325 V ⁽²⁾

(1) 90–108 V AC with reduced output power. 1000 W per PSU

(2) Install external filter and stabilizer if not met.

Mains Fuses

Table 10 Mains Fuses Recommendation

Minimum for Safe Function	Recommended for Maximum Selectivity	Maximum Allowed Fuse Rating
2x10 A /16 A ⁽¹⁾	2x16 A	2x20 A

(1) For 200–250 V range only.

External Earth Fault Circuit Breakers

If external earth fault (ground fault) circuit breakers are used, then the recommended minimum trip value is 100 mA.

8.2 +24 V DC Supply Voltage

Table 11 DC Power Requirements

Nominal	+24 V DC
Default	+27.2 V DC
Range	+20.5 to +29.0 V DC
Non-destructive range	+0 to +32 V DC
Inrush current	Max. 500 A (0.1–10 ms)

Prepared (also subject responsible if other) / XSNJOER		No. 174/1551-LZA 701 0001 Uen		
Approved EAB/ FJG/YP (Louise Cederlund)	Checked	Date 2007-06-12	Rev A	Reference

Fuses

Table 12 +24 V DC Fuse Recommendation

Minimum for Safe Function	Recommended for Maximum Selectivity	Maximum Allowed Fuse Rating
1x80 A ⁽¹⁾	1x100 A	1x200 A

(1) May be used when no transmission and/or optional equipment is installed.

8.3 –48 to –60 V DC Supply Voltage

Table 13 DC Supply Voltage Requirements

Nominal	–48 to –60 V DC
Range	–40.0 to –72.0 V DC
Non-destructive range	+0 to –80 V DC
Inrush current	200 A (0.1–5 ms)

Fuses

Table 14 –48 to –60 V DC Fuse Recommendation

Minimum for Safe Function	Recommended for Maximum Selectivity	Maximum Allowed Fuse Rating
2x32 A	2x35 A	2x40 A

8.4 Battery Backup

Battery backup can be used to power the site during mains failure and to protect the site from interruptions in the AC mains supply. It is available in an external cabinet.

In the event of mains failure, the batteries in the BBS 2000 or BBS 2202 deliver the necessary power to the radio cabinet as well as to the transmission equipment, if used. This enables the radio system to continue operating during mains failure. The transmission equipment is provided with power supply longer than the RBS.

Battery backup can be delivered for at least 1, 2, 4, 6 or 8 hours backup time, depending on the chosen configuration of the RBS. The BBS can feed +24 V DC or –48 V DC to transmission equipment. The –48 V DC supply requires an internal DC/DC converter in the BBS. It is possible to share battery backup between an RBS 2202 or 2206 and an RBS 2207.

Prepared (also subject responsible if other) / XSNJOER		No. 174/1551-LZA 701 0001 Uen		
Approved EAB/ FJG/YP (Louise Cederlund)	Checked	Date 2007-06-12	Rev A	Reference

8.5 Power Consumption

The power consumption figures in the table below show peak load. The figures in the table have been rounded off.

Table 15 Power Consumption

RBS 2207 Cabinet (fully equipped)	Power Supply Voltage		
	120–250 V AC	+24 V DC	–48 V DC
Maximum Power Consumption	1.7/2.9 ⁽¹⁾ kW	1.4 kW	1.7 kW

(1) Power consumption during maximum battery charging.

9 Transmission

The RBS 2207 is normally connected to a Distribution Frame (DF) that serves as an interface for the transmission (PCM) lines. Two PCM cables are connected to the ports on the connection field of the RBS. The RBS 2207 supports two transmission standards:

- T1 1.5 Mbit/s, 100 Ω balanced PCM line
- E1 2 Mbit/s, 75 Ω unbalanced (Transmission Adapter used), or 120 Ω balanced line

Link access procedures on C-channel (LAPD) concentration and LAPD multiplexing can be used to make the transmission resource more efficient.

PCM Overvoltage Module

This module is mounted in the DF and contains overvoltage protection for the PCM lines. If the PCM lines are terminated in equipment outside the RBS equipment room, these lines must then be protected by overvoltage protectors (OVP) in the DF. Failure to do so might damage the DXU-21, if a voltage transient is transported along the cable. The RBS 2207 is designed for 100/120 Ω balanced (twisted pair) cable. When a 75 Ω unbalanced (coaxial) cable is to be connected, the module contains a balun card that converts 75 Ω unbalanced to 100/120 Ω balanced line.

Optional Transmission Equipment

The cabinet can be connected to optional transmission equipment that is mounted externally. The optional transmission equipment used is:

- Transmission adapter to connect 75 Ω unbalanced line directly to the RBS
- MINI-LINK

Prepared (also subject responsible if other) / XSNJOER		No. 174/1551-LZA 701 0001 Uen		
Approved EAB/ FJG/YP (Louise Cederlund)	Checked	Date 2007-06-12	Rev A	Reference

- TMR 9202

10 Alarms

The RBS 2207 can be connected to a maximum of 16 external alarms. The DF is used for external alarm connection. Each alarm connection is provided with overvoltage protection. (One OVP module protects two alarm connections.) The alarm device can set the alarm by either an open or closed circuit.

The alarm device connected to the screw terminals should be isolated relay contacts. A closed contact (logic zero) is required to be below 2 k Ω , and an open contact (logic one) above 100 k Ω . The current through a closed 0 Ω contact is 1.2 mA. The voltage between terminals with an open contact is 24 V DC. The external alarms are defined during installation either using the Operation and Maintenance Terminal (OMT) or from the BSC.

11 Standards, Regulations and Dependability

In this section a brief overview of standards, type approval, and electromagnetic compatibility are stated.

11.1 Safety Standards

In accordance with the market requirements, the RBS 2207 complies with the following product safety standards:

- 73/23/EEC Low voltage directive
- IP 20 according to IEC/EN 60529
- Federal Communications Commission (FCC) rules, part 68
- EN 60950 / IEC 60950
- EN 60215 / IEC 60215
- UL 1950 / CSA C22.2 No.950

11.2 Other Standards and Regulations

Marking

The product is marked with signs to show compliance with product safety standards.

Prepared (also subject responsible if other) / XSNJOER		No. 174/1551-LZA 701 0001 Uen		
Approved EAB/ FJG/YP (Louise Cederlund)	Checked	Date 2007-06-12	Rev A	Reference

Type Approval Standards

The RBS complies with the European Community and the North America market requirements regarding radio performance. The product has the Conformité Européenne (CE) and FCC signs to show compliance to the legal requirements in respective region.

Electromagnetic Compatibility (EMC)

The RBS complies with the European Community and the North America market requirements regarding EMC. The product has the CE and FCC signs to show compliance to the legal requirements in each respective region.

Dependability

The RBS 2207 is designed for a technical lifetime of 20 years (24-hour operation). The following preventive maintenance conditions must be fulfilled to guarantee the availability of the RBS:

Fans	The fans must be inspected (cleaned if necessary) every year. The lifetime is estimated to be at least 7 years.
Air filters	The air filters must be regularly inspected and cleaned (interval depends on the environmental conditions at the site).

Vandal Resistance

Unauthorized access is not possible without damaging the unit.