

P009152A

Ericsson GSM System

# RBS 2106, RBS 2206 Hardware Reference Manual



Doc nr: 2/001 59-EN/LZT 720 0024 Uen

Rev B

**ERICSSON** 

---

**ERICSSON** 

---

Ericsson GSM System

**EN/LZT 720 0024 R2A**

**ERICSSON** 

**RBS 2106, RBS 2206 Hardware Reference Manual**

---

**ERICSSON** 

---

**ERICSSON** 

---

**ERICSSON** 

**ERICSSON** 



Uppgjord (även faktaansvarig om annan) - Prepared (also subject responsible if other) EAB/RKB/Z		Nr - No. 3/001 59-EN/LZT 720 0024 Uen
Dokansv/Godkänd - Doc respons/Approved EAB/RKB/Z	Kontr - Checked	Datum - Date 2002-11-04
		Rev B
		File

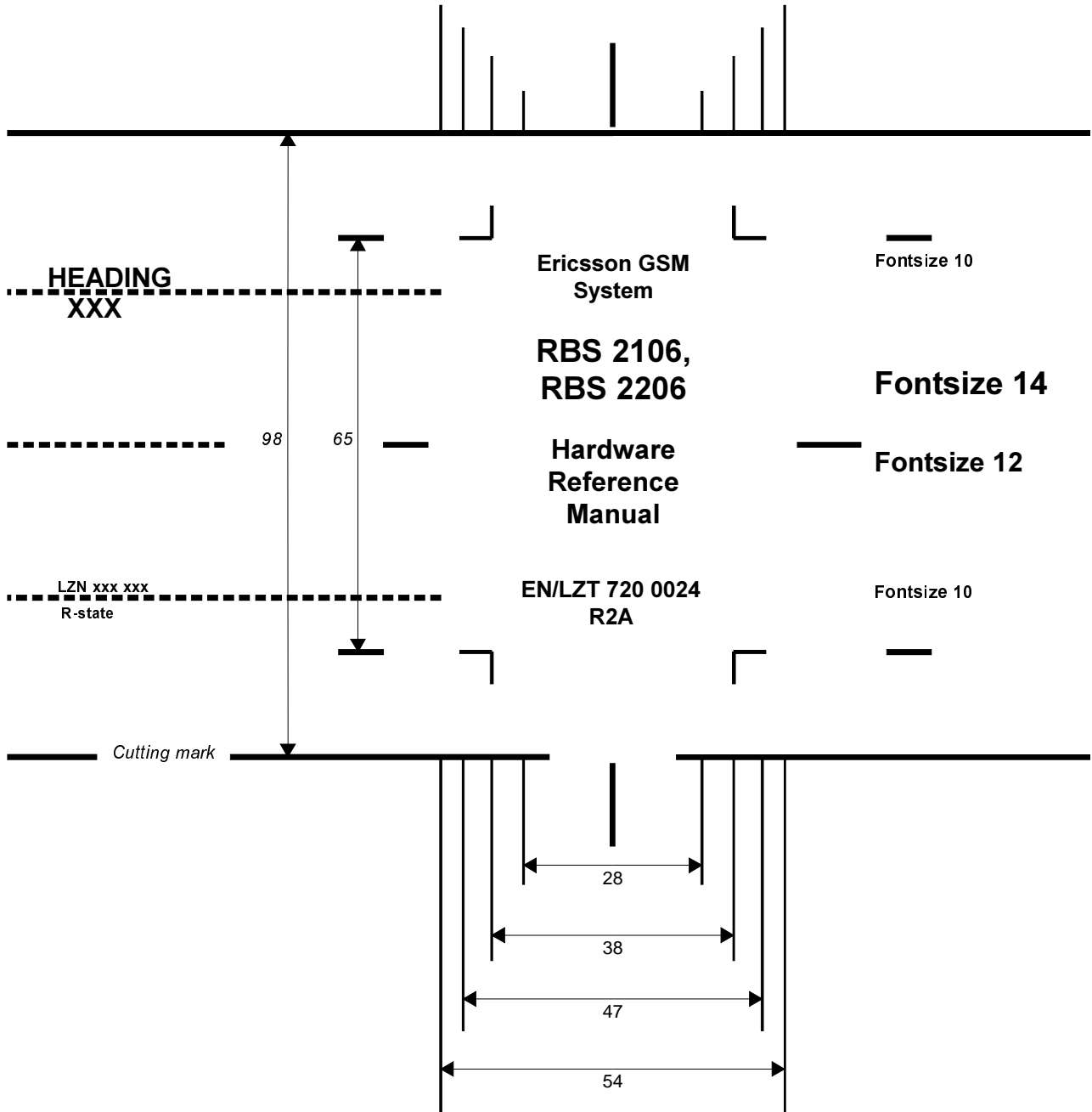



*CAPTION LIST*

Document No. 1/001 53-EN/LZT 720 0024  RBS 2106, RBS 2206 Hardware Reference Manual	Product Safety Requirements RBS 2000	2	
Date 2002-11-05	Rev A	Environmental Capabilities	3
EMC Capabilities		4	
Product and Configuration Descriptions		5	
Glossary		6	
		7	
		8	
		9	
		10	





# **RBS 2106, RBS 2206 Hardware Reference Manual**

© Ericsson Radio Systems AB — All Rights Reserved —

Due to continued progress in methodology, design and manufacturing, the contents of this document are subject to revision without notice.

# Contents

<b>1</b>	<b>Introduction .....</b>	<b>7</b>
1.1	Objectives.....	7
1.2	Target Groups.....	8
1.3	RBS 2000 Library Overview.....	8
1.4	How to Order CPI.....	8
1.4.1	Outside Ericsson.....	9
1.4.2	Inside Ericsson.....	10
1.5	Release History .....	10
1.5.1	R1A.....	10
1.5.2	R1A to R2A.....	10
<b>2</b>	<b>Product Safety Requirements RBS 2000.....</b>	<b>13</b>
2.1	References.....	13
2.2	Product Safety.....	13
2.2.1	Declaration of Conformity.....	14
<b>3</b>	<b>Environmental Capabilities.....</b>	<b>15</b>
3.1	Scope.....	15
3.2	Terminology.....	15
3.3	References.....	16
3.4	Transport -40°C - +70°C.....	16
3.4.1	General Conditions.....	16
3.4.2	Climatic Conditions.....	16
3.4.3	Biological Conditions .....	16
3.4.4	Chemically Active Substances .....	16
3.4.5	Mechanically Active Substances.....	17
3.4.6	Mechanical Conditions.....	17
3.5	Storage -25°C - +55°C.....	17
3.5.1	General Conditions.....	17
3.5.2	Climatic Conditions.....	17
3.5.3	Biological Conditions .....	18
3.5.4	Chemically Active Substances .....	18

3.5.5	Mechanically Active Substances .....	18
3.5.6	Mechanical Conditions.....	18
3.6	Handling -40°C - +70°C.....	19
3.6.1	General Conditions.....	19
3.6.2	Climatic Conditions.....	19
3.6.3	Biological Conditions .....	19
3.6.4	Chemically Active Substances .....	19
3.6.5	Mechanically Active Substances .....	19
3.6.6	Mechanical Conditions.....	19
3.7	Operation Indoor +5°C - +40°C .....	19
3.7.1	General Conditions.....	19
3.7.2	Climatic Conditions.....	20
3.7.3	Biological Conditions .....	20
3.7.4	Chemically Active Substances .....	20
3.7.5	Mechanically Active Substances.....	20
3.7.6	Mechanical Conditions.....	20
3.8	Operation Outdoor -33°C - +40°C .....	21
3.9	Operation Outdoor -33°C - +45°C .....	22
3.9.1	Climatic Conditions.....	22
3.9.2	Biological Conditions .....	22
3.9.3	Chemically Active Substances.....	22
3.9.4	Mechanically Active Substances.....	22
3.9.5	Mechanical Conditions.....	22
3.10	Operation Outdoor -33°C - +55°C .....	24
3.11	Operation Mast Mounted Equipment -33°C - +45°C.....	24
3.12	Operation Mast Mounted Equipment -33°C - +55°C.....	24
<b>4</b>	<b>EMC Capabilities.....</b>	<b>27</b>
4.1	References.....	27
4.2	Concepts.....	28
4.3	Capabilities .....	29
4.3.1	RBS Description .....	29

4.3.2	Conducted Emission.....	30
4.3.3	Radiated Emission from Enclosure.....	30
4.3.4	Conducted Immunity on AC Input Power Ports.....	31
4.3.5	Immunity on DC Input/Output Power Ports.....	32
4.3.6	Immunity on Telecommunication and External Signal Lines.....	32
4.3.7	Radiated Immunity of Enclosure Port.....	33
4.3.8	Electro-static Discharges.....	34

This page is intentionally left blank

# 1 Introduction

This Hardware Reference Manual is valid for the Ericsson GSM system BSS R8 except for the description of GSM 800, which is valid from BSS R9.

## 1.1 Objectives

This manual describes the hardware for RBS 2106 and RBS 2206, the Ericsson RBS 2000 Macro system based on 12-TRX cabinets for GSM 800, GSM 900, GSM 1800 and GSM 1900. The manual is comprised of two parts; general chapters (which apply to all RBS 2000 cabinets) and product documents (which deal with specific RBS cabinets and replaceable units).

### General Chapters

The general chapters, which apply to all RBS 2000 cabinets, are:

- Introduction
- RBS 2000 Product Safety Requirements
- Environmental capabilities
- EMC capabilities
- Glossary

### Product Documents

The product documents are designed to be modular; that is, each is an independent CPI product. Updated versions of each product document can be downloaded from CPI Store and used to update the manual. The titles and product numbers are given in the table below.

Table 1 Product documents

Title	Product Number
Radio Configurations, RBS 2106 and RBS 2206	EN/LZT 720 0318
RBS 2106 Antenna Configurations	EN/LZT 720 0319
RBS 2206 Antenna Configurations	EN/LZT 720 0320
RBS 2106 Product Description	EN/LZT 720 0222
RBS 2206 Product Description	EN/LZT 720 0225
ACCU-01, Description	EN/LZT 720 0229
ACCU-02, Description	EN/LZT 720 0230
ADM-01, Description	EN/LZT 720 0300
ASU, Description	EN/LZT 720 0232
BFU-21, Description	EN/LZT 720 0234
BFU-22, Description	EN/LZT 720 0276
CDU-F, Description	EN/LZT 720 0237
CDU-G, Description	EN/LZT 720 0236
Combined Climate Unit, Description	EN/LZT 720 0239
CXU-10, Description	EN/LZT 720 0240
DCCU, Description	EN/LZT 720 0224
DC/DC Converter, Description	EN/LZT 720 0301
DC Filter for RBS 2106, Description	EN/LZT 720 0302
DC Filter 01 for RBS 2206, Description	EN/LZT 720 0241
dTRU, Description	EN/LZT 720 0242
DXU-21, Description	EN/LZT 720 0244
FCU-01, Description	EN/LZT 720 0246
Heat Exchanger Climate Unit, Description	EN/LZT 720 0311
IDM, Description	EN/LZT 720 0247
PSU AC, Description	EN/LZT 720 0249
PSU DC, Description	EN/LZT 720 0248
TMA-CM, Description	EN/LZT 720 0250

## 1.2 Target Groups

Customers and Ericsson personnel involved in RBS activities.

## 1.3 RBS 2000 Library Overview

The Customer Product Information (CPI) for dTRU based RBS 2000 Macro comprises installation, test and maintenance, and reference manuals as well as spare parts catalogues.

For further information, see:



*Library Overview*

*LZN 302 73*



## 1.4 How to Order CPI

CPI can be ordered in the same way as all other Ericsson products using the product number to identify each product. Orders can be placed through any local Ericsson company, or alternatively, on the Internet. How operators and customers and Ericsson companies order CPI is described in detail below.

### 1.4.1 Outside Ericsson

To place an order for CPI, contact any Ericsson company and follow the same procedure as with all other Ericsson products.

The most up-to-date CPI can be downloaded from the Extranet by customers and contractors that have obtained access by visiting Ericsson's Extranet e-business site. See access information below.

#### How to Obtain Access to the Extranet

Access is granted by the Key Account Manager (KAM) from your local Ericsson company. The Extranet address is:

<https://ebusiness.ericsson.net>

To be able to access the Extranet site you need to ensure that:

- your company allows access to secure sites (HTTPS) through its firewall.
- your PC has either Microsoft Internet Explorer 4.01 with SP2 or later, or Netscape navigator 4.61 or later.
- your browser has the plug-ins necessary to view or download PDF and Microsoft office files.

If you are unsure of any of these preconditions, please check with your local IS/IT Support or help desks within your company.

#### The Access Process

- To access the site you must have an individual user name and password. To request access, send an e-mail to the support centre [asq.ex@era.ericsson.se](mailto:asq.ex@era.ericsson.se) stating your name, telephone number, e-mail address and with which customer or Ericsson company you work.

Once your access is setup, a reply with all the details you need will be sent to you.

Alternatively, you can download the Portal Order form from the Extranet.

- The first time you log in to the site, we recommend you to read the user instructions.

More information about Extranet can be found at the Extranet address below. For support on issues related to the Extranet, Tel.: +46 8 585 33085.

### 1.4.2 Inside Ericsson

The Intranet is an internal Ericsson web that can only be accessed by Ericsson personnel.

All CPI products are available on the Intranet at CPI Store:

**<http://cpistore.ericsson.se>**

Ericsson personnel, who may require access to CPI while operating outside Ericsson's firewall, can get more information about Extranet access from the following address:

**<http://inside.ericsson.se/ebusiness/>**

## 1.5 Release History

Except editorial changes such as correction of spelling, grammar and layout, this manual has been revised as follows:

### 1.5.1 R1A

The information in this manual replaces the corresponding information previously included in the following manual:



*RBS 2106, RBS 2206    EN/LZT 720 0008*  
*Reference Manual*

### 1.5.2 R1A to R2A

Chapters (documents) which have been added or updated for this release are listed in the table below.

Table 2 Revised or updated chapters (documents)

Title	New Revision No.	Reason for Revision
Radio Configurations, RBS 2106 and RBS 2206	R1A	Information has been added for CDU-G 1x4, 1x6 and 1+1+2 configurations. This chapter has been made into an independent CPI product.
RBS 2106 Antenna Configurations	R1A	Antenna connection field information has been updated for RF LMU connections. This chapter has been made into an independent CPI product.
RBS 2206 Antenna Configurations	R1A	This chapter has been made into an independent CPI product.
RBS 2106 Product Description	R3A	Information has been added for fuse requirements, ground leakage current, cable inlet measurements, acoustic dispersion, and the Heat Exchanger Climate Unit. Information has been updated for heat dissipation and RF LMU connections on the antenna connection field.
RBS 2206 Product Description	R3A	Information has been added for ground leakage current and external earth fault circuit breakers. Information has been updated for fuse requirements, battery back-up, and heat dissipation.
ADM-01, Description	R1A	This chapter is new.
Combined Climate Unit, Description	R1B	The title has been changed from <i>RBS 2106 Climate Unit, Unit Description</i> .
DC/DC Converter, Description	R1A	This chapter is new.
DC Filter for RBS 2106, Description	R1A	This chapter is new.
DC Filter 01 for RBS 2206, Description	R1B	The title has been changed from <i>DC Filter 01, Unit Description</i> .
Heat Exchanger Climate Unit, Description	R1A	This chapter is new.
PSU DC, Description	R1B	Minor editorial changes have been made.

This page is intentionally left blank

## 2 Product Safety Requirements RBS 2000

The purpose of this document is to specify the product safety requirements for RBS 2000.

### 2.1 References

73/23/EEC	Low Voltage Directive
CAN/CSA-C22.2	No 1-M94 Audio, Video and Similar Electronic Equipment
CAN/CSA-C22.2	No 950-95 Safety of Information Technology Equipment Including Electrical Business Equipment
EN 60950	Safety of Information Technology Equipment Including Electrical Business Equipment
IEC 215	Safety requirements for radio transmitting equipment
IEC 529	Classification of degrees of protection provided by enclosures (IP Code)
IEC 60950	Safety of Information Technology Equipment Including Electrical Business Equipment
UL 1419	Standard for Professional Video and Audio Equipment
UL 1950	Safety of Information Technology Equipment Including Electrical Business Equipment

### 2.2 Product Safety

This part of the document defines the Electrical, Mechanical, Heat and Fire Safety Requirements for the Radio Base Station.

#### General

The RBS is designed to comply with the following International Standards:

- 73/23/EEC Low Voltage Directive. (To achieve this, the RBS shall conform to the standards below.)
- EN 60950 "Safety of Information Technology Equipment Including Electrical Business Equipment".
- The RBS fulfils the requirements in the general IEC 60950 including national differences notified in EN 60950.
- IEC 215 Safety requirements for transmitting equipment.
- The RBS shall be listed by National Recognized Testing Laboratory (NRTL).
- The RBS fullfills encapsulation class IP XX according to IEC 529.

In addition to this the product fulfills the environmental requirements.

The RBS is so designed and constructed that, under all conditions of normal use and under a likely fault condition, it protects against personal injury from electrical shock and other hazards.

The RBS is protected against serious fire originating in the equipment as well as mechanical hazards in the equipment, as well as mechanical hazards in the meaning of the applicable standard.

**For the US the following standards are applicable:**

- UL 1950 "Safety of Information Technology Equipment Including Electrical Business Equipment".

**For Canada the following standards are applicable:**

- CAN/CSA-C22.2 No 1-M94 Audio, Video and Similar Electronic Equipment.

**2.2.1 Declaration of Conformity**

Tests and inspections shall be carried out according to ECMA requirements.

## 3 Environmental Capabilities

### 3.1 Scope

This chapter covers the environmental requirements for the indoor and outdoor temperature non-controlled operation conditions. The subjects are: Climatic, Biological, Chemically active substances, Mechanically active substances and Mechanical conditions.

### 3.2 Terminology

Definition of concepts:

#### **Normal Operation Conditions**

Environmental conditions where all units shall be able to function as specified.

#### **Safe Function**

Environmental stress above the limits for normal operation where all units shall continue to function during the stress, but performance or capacity may be reduced.

Reduction of performance or capacity shall be documented as a typical value.

When the environmental stress has dropped to normal operation conditions, function as specified shall automatically be achieved.

Safe function refers to an operation period of not more than 72 consecutive hours, and a total of not more than 15 days in one year.

#### **Non-destruction**

Environmental stress above the limits for safe function during which no function is guaranteed and performance may degrade in an unspecified manner.

When the environmental stress has dropped to normal operation conditions, no manual intervention (on site) is needed to restore full performance of the RBS.

Non-destruction refers to an operation period of not more than 96 consecutive hours, and a total of not more than 5.5 days in a 3-year period.

#### **GSM Concepts**

The GSM concepts for Normal operation and Extreme operation conditions as defined in GSM:11.20-12.3.2 are both equal to the Normal condition as defined and used in this document. This means that all RF parameters are guaranteed within the Normal condition range as defined in this document.

### 3.3 References

- IEC 721-3-.. Classification of groups of environmental parameters and their severities.
- ETSI 300 019-1-.. Classification of environmental conditions.

### 3.4 Transport -40°C - +70°C

#### 3.4.1 General Conditions

The severity of the requirements is in conformity with: IEC 721-3-2 classes 2K4/2B2/2C2/2S2/2M2. and ETS 300 019-1-2 Class 2.3 "PUBLIC transportation".

These requirements are valid for equipped cabinets (excluding batteries). The values in these conditions are valid for a maximum transport time of 3 months. The time is measured from the moment the packages are leaving the shipping store, and includes storing in connection with the transport.

**Note:** These requirements restrict flight transportation to aircrafts with pressure cabins. As modern aircrafts have pressure cabins, these limitations are expected to be only formal.

**Note:** The severity levels are chosen with equipped cabinets in mind. Therefore, transport of equipment outside the cabinets can result in extremes. These extremes shall be handled by its own packing.

#### 3.4.2 Climatic Conditions

During transportation the equipment could be exposed to extremes in temperature and humidity. The equipment must be packaged. The equipment shall be operational after being subjected to the ambient temperature and humidity stated hereafter.

The severity of these requirements are in conformity with: IEC 721-3-2 class 2K4. and ETS 300 019-1-2 Class 2.3.

#### Requirements

Table 3

Environmental Parameters	Unit	Value
Temperature	°C	-40 - +70
Relative humidity	%	5 - 100

#### 3.4.3 Biological Conditions

The severity of these requirements is in conformity with: IEC 721-3-2 class 2B2. and ETS 300 019-1-2 Class 2.3.

#### 3.4.4 Chemically Active Substances

The severity of these requirements is in conformity with: IEC 721-3-2 class 2C2. and ETS 300 019-1-2 Class 2.3.



**Note:** The values are average yearly levels of airborne contaminants that can be accepted. It is assumed that one of the contaminants is dominant at each site, and that the other is present in insignificant amounts.

### 3.4.5 Mechanically Active Substances

The severity of these requirements is in conformity with: IEC 721-3-2 class 2S2. and ETS 300 019-1-2 Class 2.3.

### 3.4.6 Mechanical Conditions

The packing and transport method shall be chosen in order not to expose the equipment to stress beyond these limits. The equipment shall function as specified when installed after test.

The severity of these requirements is in conformity with: IEC 721-3-2 class 2M2. and ETS 300 019-1-2 Class 2.3.

### Requirements

Table 4

Environmental Parameters	Unit	Value		
Vibration sinus:				
displacement	mm	3.5		
acceleration	m/s <sup>2</sup>		10	15
frequency	Hz	2 - 9	9 - 200	200 - 500
Random ASD:	m <sup>2</sup> /s <sup>3</sup>	1.0		
acceleration	m/s <sup>2</sup>	12.0		
frequency	Hz	2 - 200		
Shock:				
peak acceleration	m/s <sup>2</sup>	100		
duration	ms	11		

## 3.5 Storage -25°C - +55°C

### 3.5.1 General Conditions

The severity of the requirements is in conformity with: IEC 721-3-1 classes 1K4/1Z2/1Z3/1Z5/1B2/1C2/1S3/1M2, and ETS 300 019-1-1 Class 1.2. "WEATHERPROTECTED, not temperature-controlled storage".

During storage the equipment must be packaged. The values in these conditions are valid for a maximum storage time of 12 months. The time refers to equipment in its outer package and stored at the consignee in a conditioned store.

### 3.5.2 Climatic Conditions

The equipment must be in packaged condition.

The severity of these requirements is in conformity with IEC 721-3-1 classes 1K4/1Z2/1Z3/1Z5. and ETS 300 019-1-1 class 1.2.

**Requirements**

Table 5

Environmental Parameters	Unit	Value
Temperature	°C	-25 - +55
Relative humidity	%	10 - 100

**3.5.3 Biological Conditions**

The severity of these requirements is in conformity with IEC 721-3-1 class 1B2. and ETS 300 019-1-1 class 1.2.

**3.5.4 Chemically Active Substances**

The severity of these requirements is in conformity with: IEC 721-3-1 class IC2 and ETS 200 019-1-1 Class 1.2.

**Note:** The values are average yearly levels of airborne contaminants that can be accepted. It is assumed that one of the contaminants is dominant at each site, and that the other is present in insignificant amounts.

**3.5.5 Mechanically Active Substances**

The severity of these requirements is in conformity with: IEC 721-3-1 class 1S3. and ETS 300 019-1-1 Class 1.2.

**3.5.6 Mechanical Conditions**

The packing and transport method shall be chosen in order not to expose the equipment to stress beyond these limits. The equipment shall function as specified when installed after test.

The severity of these requirements is in conformity with: IEC 721-3-1 class 1M2. and ETS 300 019-1-1 Class 1.2.

**Requirements**

Table 6

Environmental Parameters	Unit	Value
Vibration sinus:		
displacement	mm	3.5
acceleration	m/s <sup>2</sup>	10
frequency	Hz	2 - 9      9 - 200
Shock:		
peak acceleration	m/s <sup>2</sup>	40
duration	ms	22

## 3.6 Handling -40°C - +70°C

### 3.6.1 General Conditions

This section refers to shorter periods of transport and storage in unpacked conditions. Precautions to avoid condensation before subjecting the equipment to operational conditions are necessary.

### 3.6.2 Climatic Conditions

During handling the equipment withstands the conditions stated in *Section 3.4.2 on page 16* in this document.

### 3.6.3 Biological Conditions

During Handling the equipment withstands the conditions stated in *Section 3.4.3 on page 16* in this document.

### 3.6.4 Chemically Active Substances

During Handling the equipment withstands the conditions stated in *Section 3.4.4 on page 16* in this document.

### 3.6.5 Mechanically Active Substances

During Handling the equipment withstands the conditions stated in *Section 3.4.5 on page 17* in this document.

### 3.6.6 Mechanical Conditions

The equipment endures stresses normal for handling, during handling the equipment withstand the conditions stated in *Section 3.4.6 on page 17* in this document.

## 3.7 Operation Indoor +5°C - +40°C

### 3.7.1 General Conditions

The severity of these requirements is in conformity with: IEC 721-3-3 classes 3K3/3Z2/3Z4/3B1/3C2(3C1)/3S2/3M1. and ETS 300 019-1-3 Class 3.1 "TEMPERATURE-controlled locations".

This clause refers to the environment which an RBS for indoor use shall endure.

**Note:** The different operating temperature levels according to Safe function and Non-destruction, refer to situations where the RBS is supposed to have been operating in "normal condition" mode for a certain time. Then the surrounding temperature in the compartment increases (decreases) according to these figures. Accordingly, this means that the surrounding temperature is allowed to change within the limits while the RBS still operates and has its own loss of energy.

### 3.7.2 Climatic Conditions

The severity of these requirements are in conformity with: IEC 721-3-3 classes 3K3/3Z2/3Z4. and ETS 300 019-1-3 Class 3.1.

Table 7

Environmental Parameters	Unit	Value		
		Normal Condition	Safe Function	Non-destruction
Temperature	°C	+5 - +40	0 - +45	-10 - +55
Relative humidity	%	5 - 85	5 - 90	5 - 90

### 3.7.3 Biological Conditions

#### Requirements

There are no requirements for this condition.

### 3.7.4 Chemically Active Substances

The severity of these requirements is in conformity with: IEC 721-3-3 classes /3C2(3C1)/. and ETS 300 019-1-3 Class 3.1.

**Note:** The values are average yearly levels of airborne contaminants that can be accepted. It is assumed that one of the contaminants is dominant at each site, and that the other is present in insignificant amounts.

### 3.7.5 Mechanically Active Substances

The severity of these requirements is in conformity with: IEC 721-3-3 class /3S2/. and ETS 300 019-1-3 Class 3.1.

### 3.7.6 Mechanical Conditions

The severity of these requirements is in conformity with: IEC 721-3-3 class/3MI/. and ETS 300 019-1-3 class 3.1.

Table 8

Environmental Parameters	Unit	Value	
Vibration sinus:			
displacement	mm	0.6	
acceleration	m/s <sup>2</sup>		2
frequency	Hz	2 - 9	9 - 200
Vibration random:			
ASD	m <sup>2</sup> /s <sup>3</sup>	0.1	1)
ASD	m <sup>2</sup> /s <sup>3</sup>	0.2	2)
acceleration	m/s <sup>2</sup>	3.8	1)
acceleration	m/s <sup>2</sup>	5.4	2)
frequency	Hz	2 - 200	
Shock:			
peak acceleration	m/s <sup>2</sup>	40	3)
duration	ms	11	

1) Safe function

2) Non-destruction

3) This requirement belongs to the Safe function with the exemption: performance of the RBS shall be verified as "no loss of calls".

### Seismic Exposure

The complete equipped RBS shall be tested for seismic exposure. Deviations shall be reported.

Safe function during seismic exposure. Deviations shall be reported.

Table 9

Test frequency range	1 - 15 Hz
Required Response Spectrum	RRS
Shape of RRS	as IEC fig. 3
Number of time scale histories	1/ testing direction
Duration of time scale histories	35 s
Number of testing directions	3

If necessary there are possibilities to equip the RBS with an optional Seismic Exposure protection device.

## 3.8 Operation Outdoor -33°C - +40°C

This Environmental class corresponds in full to Operation Outdoor -33°C - +45°C with the exception of the upper temperature limit.

### 3.9 Operation Outdoor -33°C - +45°C

The severity of the requirements is in conformity with: IEC 721-3-4 classes 4K2/4Z5/4Z7/4B1/4C2(4C3)/4S2/4M5. and ETS 300 019-1-4 Class 4.1. "NON-WEATHERPROTECTED location", except for the temperature range which is extended to +45°C.

This clause refers to the environment which an RBS for outdoor non-weather protected location endures.

The figures below refer to the environment that surrounds the cabinet, and the temperature is the shaded air temperature.

#### 3.9.1 Climatic Conditions

The severity of these requirements is in conformity with: IEC 721-3-4 classes 4K2/4Z5/4Z7. and ETS 300 019-1-4 Class 4.1. In addition to this Ericsson demands more rigorous values than stated by IEC and ETSI above.

The RBS shall be designed for a power loss of max. 48 hours. This applies both to installation and operation.

Table 10

Environmental Parameters	Unit	Value	
		Normal Condition	Non-destruction
Temperature	°C	-33 - +45	-40 - +70
Relative humidity	%	15 - 100	15 - 100

#### 3.9.2 Biological Conditions

The severity of these requirements is in conformity with: IEC 721-3-4 class /4B1/. and ETS 300 019-1-4 Class 4.1.

#### 3.9.3 Chemically Active Substances

The severity of these requirements is in conformity with: IEC 721-3-4 classes /4C2(4C1)/. and ETS 300 019-1-4 Class 4.1.

**Note:** The values are average yearly levels of airborne contaminants that can be accepted. It is assumed that one of the contaminants is dominant at each site, and that the other is present in insignificant amounts.

#### 3.9.4 Mechanically Active Substances

The severity of these requirements is in conformity with: IEC 721-3-4 class /4S2/. and ETS 300 019-1-4 Class 4.1.

#### 3.9.5 Mechanical Conditions

The severity of these requirements is in conformity with: IEC 721-3-4 class /4M5/. and ETS 300 019-1-4 Class 4.1.

Table 11

Environmental Parameters	Unit	Value	
Vibration sinus:			
displacement	mm	0.6	
acceleration	m/s <sup>2</sup>		2
frequency	Hz	2 - 9	9 - 200
no. of sweep cycles		5	
no. of test directions		3	
testing method		IEC 68-2-6	
Vibration random:			
ASD	m <sup>2</sup> /s <sup>3</sup>	0.1	1)
ASD	m <sup>2</sup> /s <sup>3</sup>	0.2	2)
acceleration	m/s <sup>2</sup>	3.8	1)
acceleration	m/s <sup>2</sup>	5.4	2)
frequency	Hz	2 - 200	
testing method		IEC 68-2-64	
Shock:			
		< 100 kg	> 100 kg
peak acceleration	m/s <sup>2</sup>	250	100
duration	ms	6	6
pulse shape		half sine	
no. of shock pulses		500 per direction	
no. of test directions		6	
testing method		IEC 68-2-27	

1) Safe function

2) Non-destruction

3) These requirements belong to the Safe function with one exemption: performance of the RBS shall be verified as "no loss of calls".

### Seismic Exposure

The complete equipped RBS shall be tested for seismic exposure. Deviations shall be reported.

Safe function during seismic exposure. Deviations shall be reported.

Table 12

Test frequency range	1 - 15 Hz
Required Response Spectrum	RRS
Shape of RRS	as IEC fig 3
Number of time scale histories	1/ testing direction
Duration of time scale histories	35 s
Number of testing directions	3

There are possibilities to equip the RBS with an optional Seismic Exposure protection device.

### 3.10 Operation Outdoor -33°C - +55°C

This Environmental class corresponds in full to Operation Outdoor -33°C - +45°C with the exception of the upper temperature limit.

### 3.11 Operation Mast Mounted Equipment -33°C - +45°C

This Environmental class corresponds to Operation Outdoor -33°C - +45°C with the exceptions stated below.

Table 13

Environmental Parameters	Unit	Value	
		Normal Condition	Non-destruction
Temperature	°C	-33 - +45	-40 - +70
Change of temperature	°C/min	6	6
Vibration sinus:			
displacement	mm	3.0	
acceleration	m/s <sup>2</sup>		10
frequency	Hz	2 - 9	9 - 200
Vibration random:			
ASD	m <sup>2</sup> /s <sup>3</sup>	0.5	
frequency	Hz	2 - 200	
duration of exposure	min	30	
no. of test directions	Hz	3	
Fauna	none	Not Appl.	Not Appl.

### 3.12 Operation Mast Mounted Equipment -33°C - +55°C

This Environmental class corresponds to Operation Outdoor -33°C - +55°C with the exceptions stated below.



Table 14

Environmental Parameters	Unit	Value	
		Normal Condition	Non-destruction
Temperature	°C	-33 - +55	-40 - +70
Relative humidity	%	5 - 100	5 - 100
Absolute humidity	g/m <sup>3</sup>	0.26 -40	0.26 - 40
Change of temperature	°C/min	6	6
Rain temperature	°C	5	5
Vibration sinus:			
displacement	mm	3	
acceleration	m/s <sup>2</sup>		10
frequency	Hz	2 - 9	9 - 200
Vibration random:			
ASD	m <sup>2</sup> /s <sup>3</sup>	0.5	0.2
frequency	Hz	2 - 200	200 - 500
Shock:			
peak acc.	m/s <sup>2</sup>	100	1)
duration	ms	11	
Fauna	none	Not Appl.	Not Appl.

1) The requirements belong to the Safe function with one exemption: performance of the RBS shall be verified as "no loss of calls".

This page is intentionally left blank

## 4 EMC Capabilities

This specification covers the capabilities of the RBS 2000 in respect of EMC (ElectroMagnetic Compatibility). The capabilities include conducted and radiated emission as well as conducted and radiated immunity thresholds.

The internal EMC capabilities of RBS 2000 and interference appearing on antenna ports are not covered by this chapter.

### 4.1 References

1. 89/336/EEC EMC directive  
Council directive of 3 May 1989 on approximation of laws of the Member States relating to electromagnetic compatibility
2. ETS 300 342-2, Nov 1994  
EMC for European digital cellular telecommunication (GSM) mobile radio and ancillary equipment.
3. EN 55 022, April 1987  
Limits and methods of Measurement of Radio Interference Characteristics of Information Technology Equipment
4. EN 50 081-1, January 1992  
Electromagnetic compatibility - Generic emission standard, Part 1: Residential, commercial and light industry
5. EN 50 082-1, January 1992  
Electromagnetic compatibility - Generic immunity standard, Part 1: Residential, commercial and light industry
6. IEC 801-3, 1984  
Radiated electromagnetic field requirement
7. EN 61000-3-2, EMC part 3, section 2  
limits for harmonic current emissions, 1995
8. EN 61000-3-3, EMC part 3, section 2  
limitation of voltage fluctuations and flicker in low-voltage supply systems for equipment with rated current <16 A, 1994
9. EN 61000-4-2, 1995  
Electrostatic discharge requirements
10. EN 61000-4-4, 1995  
Electrical fast transient/burst requirement
11. EN 61000-4-5  
Surge Immunity Requirements
12. EN 61000-4-8, 1993

- Power frequency magnetic fields immunity tests
13. EN 61000-4-11  
Voltage Dips, short interruptions and voltage variations.  
Immunity tests
  14. VDE 0878, 1986  
Radio Interface Suppression of Telecommunication Systems and Apparatus
  15. ITU-T Recommendation K.20, 1984  
Resistibility of Telecommunication Switching Equipment to Overvoltages and Overcurrents.

## 4.2 Concepts

External signal line - outdoor systems

	Cable or lead longer than 1 metre intended for connection to units located outside the cabinet
Telecommunication line	Cable intended for connection to a public network
Enclosure Port	The physical boundary of the RBS through which electromagnetic fields may radiate or impinge
Performance Criteria A	The system shall continue to operate as intended. During the test, no degradation of performance or loss of function is allowed below the specified test level
Performance Criteria B	The system shall continue to operate as intended after the test. During the test, degradation of performance is however allowed below the specified test level. No change of actual operating state or stored data is allowed
Performance Criteria C	Temporary loss of function is allowed, provided the function is self-recoverable or can be restored by the operation of the controls
Performance Criteria CT	Continuous phenomena applied to Transmitters. A communication link shall be established at the start of the test and maintained during the test. For the system the RXQUAL (as defined in GSM 05.08) of the downlink shall not exceed three, measured during each individual exposure in the test sequence

Performance Criteria TT	Transient phenomena applied to Transmitters. A communication link shall be established at the start of the test and maintained during and after injection of the transients
Performance Criteria CR	Continous phenomena applied to Receivers. A communication link shall be established at the start of the test and maintained during the test. For the system the RXQUAL (as defined in GSM 05.08) of the uplink shall not exceed three, measured during each individual exposure in the test sequence
Performance Criteria TR	Transient phenomena applied to Receivers. A communication link shall be established at the start of the test and maintained during and after injection of the transients
Performance Criteria A(K.20):	The test object shall withstand the test without damage or other disturbances after the test
Performance Criteria B(K.20):	A fire hazard should not arise in the test object. Any damage or permanent malfunction occuring should be confined to a small number of external line interface circuits.

## 4.3 Capabilities

### 4.3.1 RBS Description

#### Hardware

The capabilities are tested for an RBS equipped with a minimum representative configuration of units. This system is representative of installed systems in terms of function, which includes at least one of each function unit type, and electromagnetic radiation characteristics. The number and types of sub-units are given from results of investigations in accordance with ETS 300 342-2, Nov 1994.

#### Software

The capabilities are valid for a standard setup of system software with default parameters.

#### Performance

For the immunity capabilities the RBS is operating and will fulfil the performance criteria stated for each test.

For emission capabilities all equipment in the RBS was enabled during verification to create the worst emission case.

### EMC directive

The EMC capabilities of the RBS fulfills the mandatory requirements specified in the EMC directive, 89/336/EEC, which gives compliance for trade in EU member countries.

### Generic Standards

The following generic standards are fulfilled by the system:

EN 50 081–1, Jan 1992 Emission

EN 50 082–1, Jan 1992 Immunity

## 4.3.2 Conducted Emission

*Table 15 Voltage fluctuation on AC power supply leads*

Basic standard	EN 61000-3-3
Limit	Set by Table II in EN 61000-3-3

*Table 16 Harmonics on AC power supply leads*

Basic standard	EN 61000-3-2
Limit	Set by Table 1 in EN 61000-3-2

*Table 17 Interference on AC power supply leads*

Basic standard	EN 55 022
Limit	Class B

Limit standard	VDE 0878, Conducted emission, part 1
Limit	Class B

*Table 18 Interference on DC power supply leads*

Basic standard	EN 50 022 and proposed amendment to CISPR 22
Limit	Class B

Limit standard	ETS 300 342-2, Nov 1994
Limit	Class B

*Table 19 Interference on signal and telecommunication lines*

Basic standard	CISPR/G(sec) December 1993
----------------	----------------------------

## 4.3.3 Radiated Emission from Enclosure

*Table 20 Electric field emission*

Basic standard	EN 55 022
Limit	Class B

Table 21 *Magnetic field emission*

Limit standard	VDE 0878, Magnetic emission, part 1
Limit	Class B

#### 4.3.4 Conducted Immunity on AC Input Power Ports

Table 22 *Fast transient test*

Basic standard	EN 61000-4-4
Test level	4 kV common mode between all lines and cabinet ground reference
Performance	Criteria B

Limit standard	ETS 300 342-2
Test level	4 kV common mode between all lines and cabinet ground reference
Performance	Criteria A for a complete system Criteria TT for transmitter units Criteria TR for receiver units

Table 23 *Surge test*

Limit standard	ETS 300 342-2
Test level	2 kV common mode between all lines and cabinet ground reference <sup>1)</sup> 1 kV differential mode, between line and line
Performance	Criteria A for a complete system Criteria TT for transmitter units Criteria TR for receiver units

<sup>1)</sup> System primary protected

Table 24 *RF common mode test*

Limit standard	ETS 300 342-2
Test level	10 V(rms)
Performance	Criteria A for a complete system Criteria CT for transmitter units Criteria CR for receiver units

Table 25 *Voltage dips and interruptions on AC ports*

Basic standard	EN 61000-4-11
Performance	Criteria A for a complete system

### 4.3.5 Immunity on DC Input/Output Power Ports

Table 26 Fast transient test

Basic standard	EN 61000-4-4
Test level	2 kV common mode between all lines and cabinet ground reference
Performance	Criteria B for a complete system

Limit standard	ETS 300 342-2
Test level	2 kV common mode between all lines and cabinet ground reference
Performance	Criteria A for a complete system Criteria TT for transmitter units Criteria TR for receiver units

Table 27 Surge test

Limit standard	ETS 300 342-2
Test level	1 kV common mode between line and cabinet ground reference 0.5 kV differential mode, between line and line
Performance	Criteria A for a complete system Criteria TT for transmitter units Criteria TR for receiver units

Table 28 RF common mode test

Limit standard	ETS 300 342-2
Test level	3 V(rms)
Performance	Criteria A for a complete system Criteria CT for transmitter units Criteria CR for receiver units

### 4.3.6 Immunity on Telecommunication and External Signal Lines

Table 29 Fast transient test

Basic standard	EN 61000-4-4
Test level	2 kV common mode between line and cabinet ground reference
Performance	Criteria B

Limit standard	ETS 300 342-2
Test level	4 kV common mode between line and cabinet ground reference
Performance	Criteria A for a complete system Criteria TT for transmitter units Criteria TR for receiver units



Table 30 Surge test 1.2/50 pulses

Limit standard	EN 61000-4-5
Test level	2 kV common mode between line and cabinet ground reference 1 kV differential mode between line and line
Performance	Criteria B for a complete system Criteria TT for transmitter units Criteria TR for receiver units

Table 31 Surge test 10/700 pulses

Limit standard	EN 61000-4-5
Test level	1 kV common mode between line and cabinet ground reference 1 kV differential mode between line and line
Performance	Criteria B for a complete system Criteria TT for transmitter units Criteria TR for receiver units

Table 32 Power induction test

Basic standard	ITU-T K.20
Test level	600 V(rms) common mode
Performance	Criteria A(K.20)

Table 33 RF common mode test

Limit standard	ETS 300 342-2
Test level	10 V(rms)
Performance	Criteria A for a complete system Criteria CT for transmitter units Criteria CR for receiver units

### 4.3.7 Radiated Immunity of Enclosure Port

Table 34 Immunity of continuous electric fields

Basic standard	IEC 801-3
Test level	10 V/m
Performance	Criteria A

Limit standard	ETS 300 342-2
Test level	10 V/m, 80 MHz - 1 GHz
Frequency range	30 V/m, 1 GHz-20 GHz
Performance	Criteria A for a complete system

	Criteria CT for transmitter units Criteria CR for receiver units
--	---

*Table 35 Immunity of 50/60 Hz magnetic fields*

Basic standard	EN 61000-4-8
Test level	10 A/m, 50/60 Hz
Performance	Criteria A

### 4.3.8 Electro-static Discharges

*Table 36 Immunity of enclosure port*

Basic standard	EN 61000-4-2
Test level	Air discharges: 15 kV Contact discharges: 8 kV
Performance	Criteria B

Limit standard	ETS 300 342-2
Test level	Air discharges: 8 kV Contact discharges: 4 kV.
Performance	Criteria A for a complete system Criteria TT for transmitter units Criteria TR for receiver units

*CAPTION LIST*

		RBS 2106 Product Description	<b>1</b>
		RBS 2206 Product Description	<b>2</b>
		RBS 2106, RBS 2206 Radio Configurations	<b>3</b>
Document No. 2/001 53-EN/LZT 720 0024		RBS 2106 Antenna Configurations	<b>4</b>
RBS 2106, RBS 2206 Hardware Reference Manual		RBS 2206 Antenna Configurations	<b>5</b>
		ACCU-01, Description	<b>6</b>
Date 2002-11-05	Rev A	ACCU-02, Description	<b>7</b>
		ADM-01, Description	<b>8</b>
		ASU, Description	<b>9</b>
		BFU-21, Description	<b>10</b>
		BFU-22, Description	<b>11</b>
		CDU-F, Description	<b>12</b>
		CDU-G, Description	<b>13</b>
		Combined Climate Unit, Description	<b>14</b>
		CXU-10, Description	<b>15</b>
		DCCU, Description	<b>16</b>
		DC/DC Converter, Description	<b>17</b>
		DC Filter for RBS 2106, Description	<b>18</b>
		DC Filter 01 for RBS 2206, Description	<b>19</b>
		dTRU, Description	<b>20</b>
		DXU-21, Description	<b>21</b>
		FCU-01, Description	<b>22</b>
		Heat Exchanger Climate Unit, Description	<b>23</b>
		IDM, Description	<b>24</b>
		PSU AC, Description	<b>25</b>
		PSU DC, Description	<b>26</b>
		TMA-CM, Description	<b>27</b>
			<b>28</b>
			<b>29</b>
			<b>30</b>
			<b>31</b>



# RBS 2106

## Radio Base Station

### Product Description

The RBS 2106, a member of the RBS 2000 family, is a 12 TRX radio base station for outdoor applications. RBS 2106 can be configured for omni cells, or for multi-sector cells of up to three sectors.

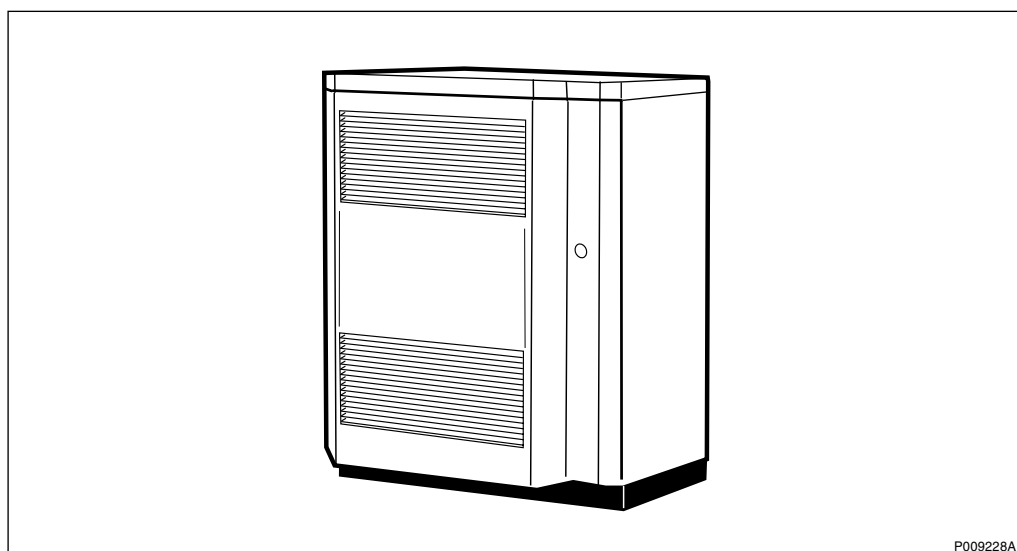

P009228A

## Contents

<b>1</b>	<b>Product Overview</b>	<b>3</b>
1.1	Main features	3
1.2	Variants	4
1.3	Optional Equipment	4
<b>2</b>	<b>Dimensions</b>	<b>5</b>
<b>3</b>	<b>Space requirements</b>	<b>6</b>
<b>4</b>	<b>Environment</b>	<b>7</b>
4.1	Operating Environment	8
4.2	Environmental Impact	8
4.3	Compliance Distances for Electromagnetic Exposure	10
4.4	Materials	12
<b>5</b>	<b>Hardware Units</b>	<b>12</b>
5.1	Standard Hardware Units	13
5.2	Optional Hardware Units	16
<b>6</b>	<b>Interfaces</b>	<b>18</b>
6.1	External connections	18
6.2	Test interface	22
6.3	Operator Interface	22
<b>7</b>	<b>Power System</b>	<b>24</b>
7.1	Power Supply	25
7.2	Battery Back-up	26
7.3	Output Power	26
7.4	Power Consumption	27
<b>8</b>	<b>Transmission</b>	<b>27</b>
<b>9</b>	<b>External Alarms</b>	<b>27</b>
<b>10</b>	<b>Standards, Regulations and Dependability</b>	<b>27</b>
10.1	Safety Standards	27
10.2	Other Standards and Regulations	28

# 1 Product Overview

The RBS 2106 is a high-capacity outdoor base station. It is used for outdoor applications, with up to six double Transceiver Units (dTRU). There is space inside the cabinet for transmission equipment and battery back-up.

The RBS 2106 is designed to be transported as a fully-assembled cabinet to the site. All units in the cabinet are easily accessible from the front of the cabinet, which means that the cabinet can be mounted against a wall.

## 1.1 Main features

The RBS 2106 can support the following features:

- 12 TRXs
- Co-siting (antenna sharing) with TDMA, WCDMA systems
- Discontinuous transmission/reception
- Duplex filters
- Dynamic power regulation
- Encryption/ciphering
- EDGE (hardware prepared)
- Expansion by TG-synchronisation
- External alarms
- Frequency hopping
- Internal battery back-up in three variants: One hour, half hour, or none.
- Positioning with GPS/LMU
- Power Supply System: Can be connected to 200 – 250 V AC mains supplies.
- Radio configurations supported on 800, 900, 1800 and 1900 MHz
- Receiver diversity
- Transmission Interface: The following transport network interface alternatives exist:
  - T1 1.5 Mbit/s, 100  $\Omega$ , with internal synchronisation
  - E1 2 Mbit/s, 75  $\Omega$ , with PCM synchronisation
  - E1 2 Mbit/s, 120  $\Omega$ , with PCM synchronisation
- Wide range power input

## 1.2 Variants

The following variants are available and can be combined according to ordering information:

- Two climate systems, Combined Climate Unit or Air-to-Air Heat Exchanger
- Available in two standard colours
- AC service outlet

## 1.3 Optional Equipment

The equipment listed below is available, but is not necessary for basic operation:

- ADM
- ASU
- Base frame
- Battery back-up
- Bias injector
- DC/DC converter
- DC Filter
- ddTMA
- DXX – two card
- ESB
- External alarms
- GPS/LMU (mounted internally or externally)
- Minilink
- Optional Expansion Unit
- Overvoltage protection (OVP) for external Alarms
- Smoke detector
- TMA-CM
- Transmission adapter



## 2 Dimensions

This section describes the RBS 2106 dimensions, space requirements and colour.

### Size and weight

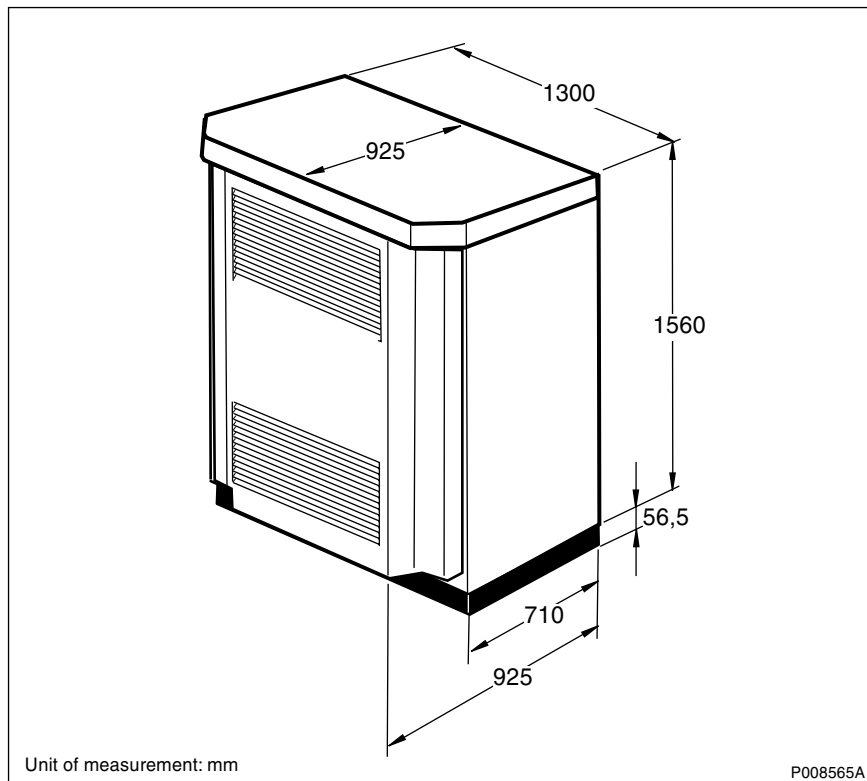

Figure 1 RBS 2106 dimensions

Table 1 RBS 2106 weights

Unit	Weight
Fully equipped including batteries	685 kg
Fully equipped excluding batteries	560 kg
Door with climate unit	150 kg

### Surface and Colour

The RBS 2106 has a surface quality according to Ericsson standard class A3/B6.

Table 2 RBS 2106 colours

Colour	Reference number	Ericsson number
Grey	RAL 7035	MZY 543 03/8119
Green	NCS 8010-G 10Y	MZY 543 03/685

### 3 Space requirements

Installation and maintenance require that the door can be opened at least 90°. In practice this means that the space in front of the cabinet must be kept clear for a distance of 1300 mm, see figure below. No free space is needed at the back of the cabinet, but to ensure that the door can be opened easily there must be at least 20 cm of free space to the left of the cabinet.

If the RBS is located next to another cabinet of the same depth, no adjacent space is required. If the RBS is placed next to a wall, or any object protrudes on the left side, then 175 mm clearance is required to the left of the cabinet.

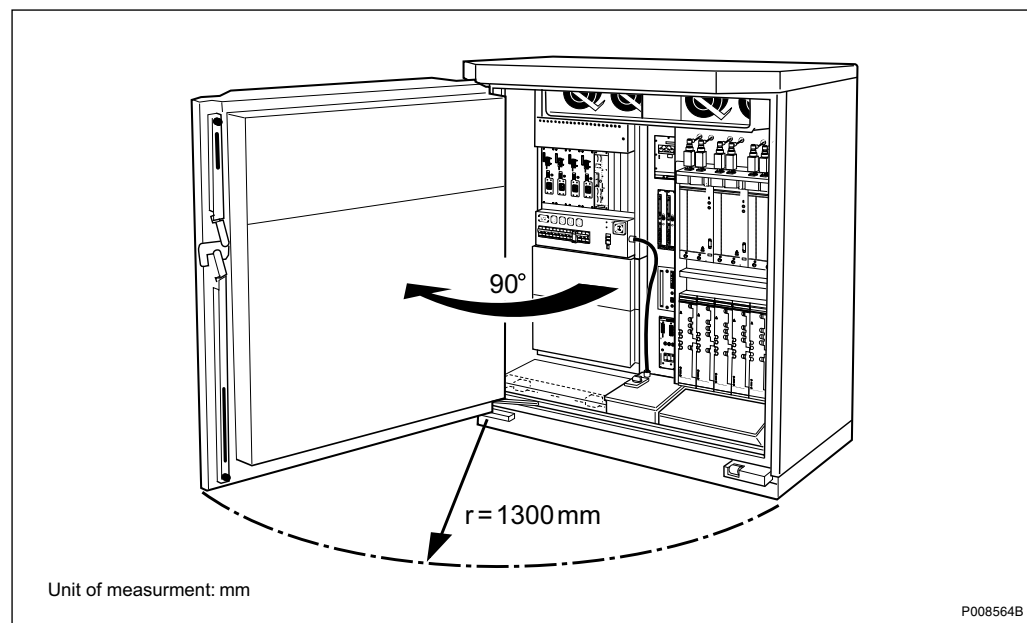

Figure 2 Door opening requirements

**Note:** All installation and maintenance work can be done with the door opened 90°.

During service a tent can be placed over the cabinet to protect the equipment from unsuitable weather conditions.

### Footprint

The footprint of the RBS 2106 is 1300 mm wide and 710 mm deep. Note that the door, which is 242 mm deep, is not included in the footprint, as it does not reach down to the ground. The installation frame of the RBS 2106 has the same bottom holing pattern as that of the RBS 2102.

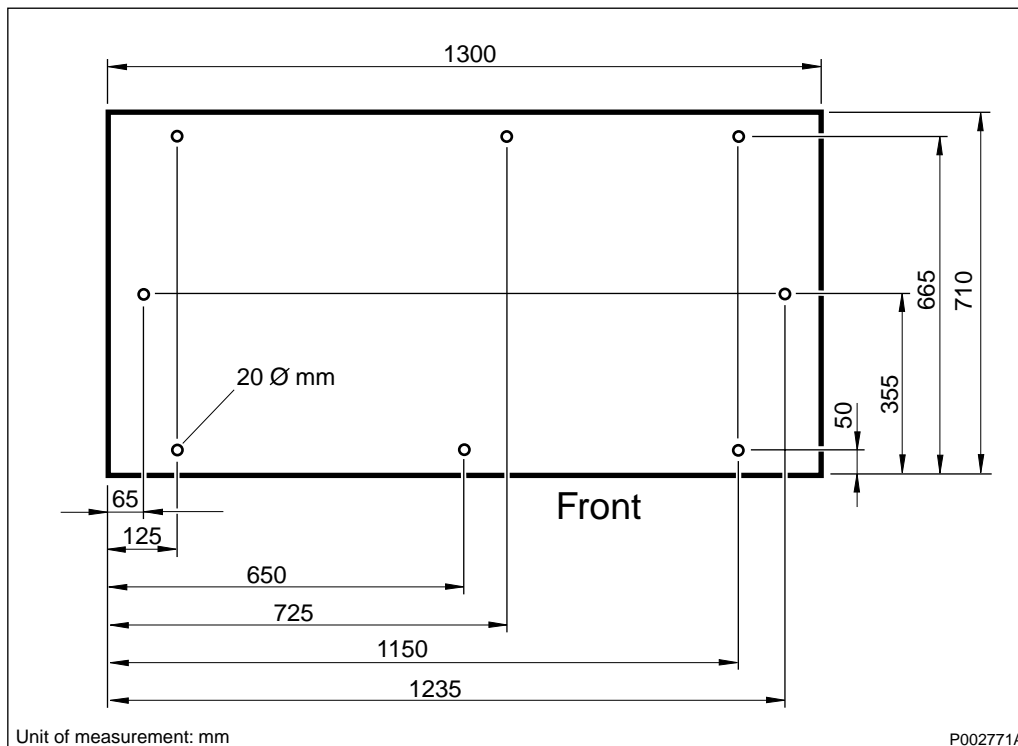

Figure 3 Base frame and installation frame holing pattern

## 4 Environment

The RBS 2106 is designed to operate within the limits stated for climatic requirements listed in the table below and to withstand ground vibrations as stated below.

## 4.1 Operating Environment

### Climatic Requirements

Table 3 Climatic requirements

Safe function	Temperature	Relative humidity
Normal Conditions	-33° – +45°C <sup>(1)</sup>	15 – 100%
Transport	-40° – +70°C	5 – 100%
Storage	-25° – +55°C	10 – 100%
Handling	-40° – +70°C	5 – 100%

(1) Upper limit +40°C with the Air-to-Air Heat Exchanger.

### Ground Vibrations

The RBS 2106 is designed to fulfill earthquake protection according to IEC 68–2–57.

### Levelling

In order to level the cabinet, the floor must be level to within  $\pm 3$  mm/2000 mm and the floor gradient be within  $\pm 0.1^\circ$ .

## 4.2 Environmental Impact

This section describes the effects that the cabinet has on the environment.

### Heat Dissipation

The RBS 2106 generates an average heat load of 3000 W. The exact figure is dependent upon configuration, equipment and site-specific conditions.

### Acoustic Dispersion

The cabinet noise dispersion for an RBS 2106 with Combined Climate Unit is shown in the two figures below. The figures show the noise dispersion generated by a free-standing cabinet and by a cabinet mounted against a wall.

**Note:** The acoustic noise dispersion values for a free-standing cabinet and a cabinet installed against a wall were tested according to the ISO 9614-2 standard, however deviations from these values may be experienced due to the nature of materials in the environment where the cabinet is installed. Objects may reflect or absorb sound and will affect acoustic dispersion.

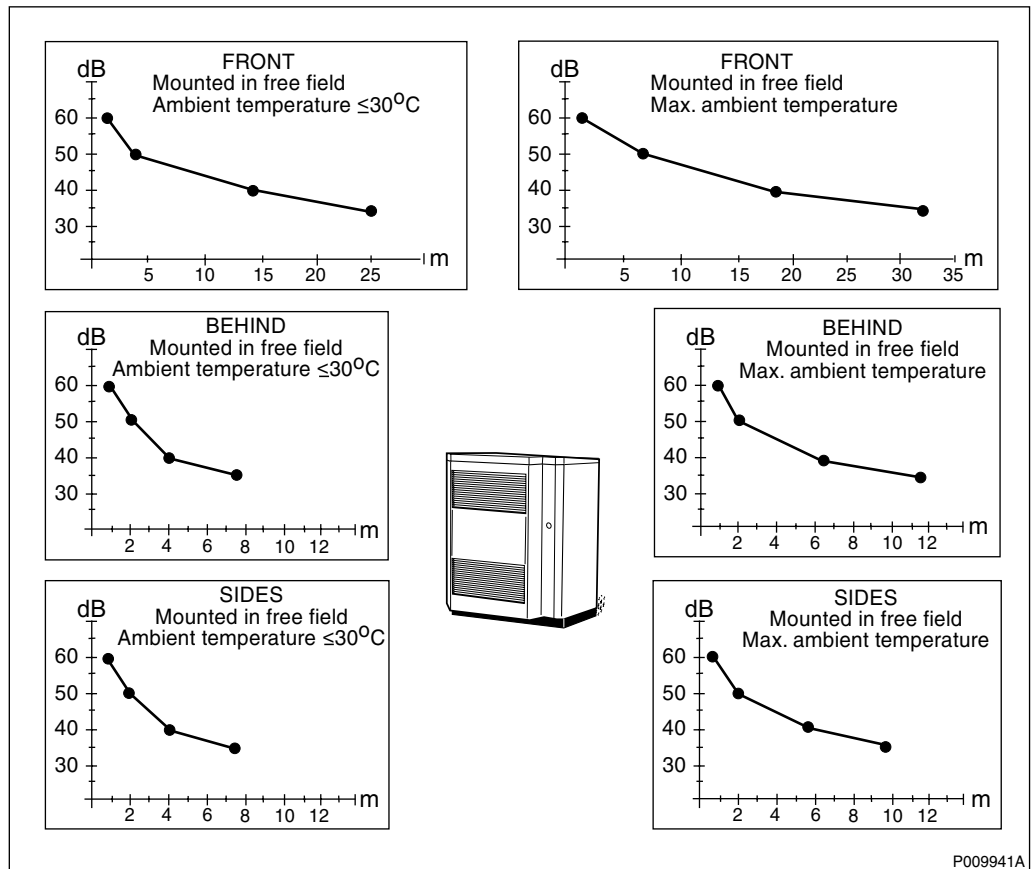

P009941A

Figure 4 Acoustic dispersion for a free-standing RBS 2106 with Combined Climate Unit

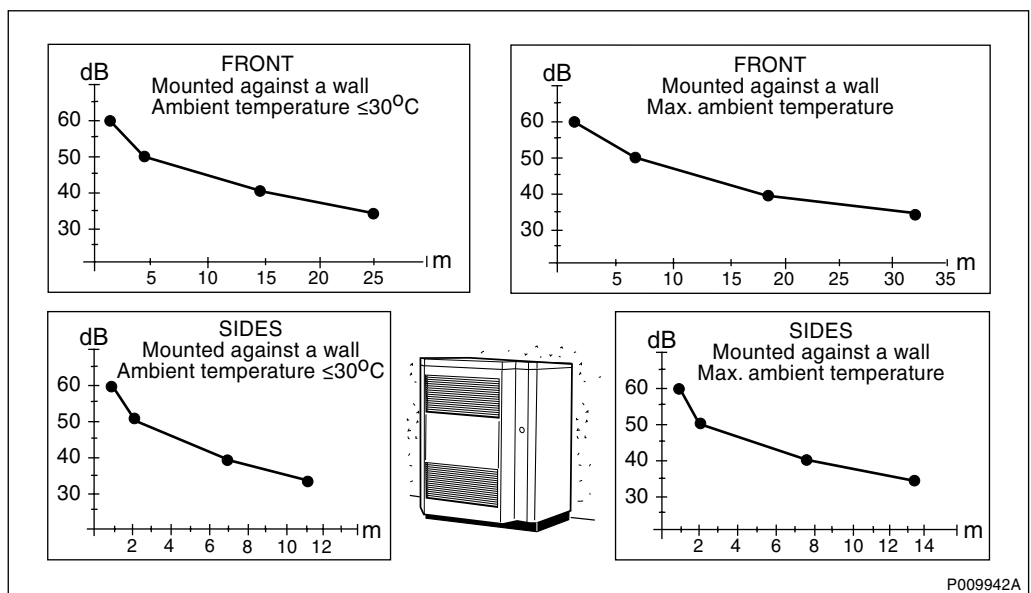

P009942A

Figure 5 Acoustic dispersion for a wall-mounted RBS 2106 with Combined Climate Unit

### 4.3 Compliance Distances for Electromagnetic Exposure

The compliance distance is the minimum separation that should be kept between an antenna and a person to ensure that RF exposure limits are not exceeded.

Ericsson has performed a near-field RF exposure assessment of typical configurations of the RBS 2106 with a recommended antenna. The resulting dimensions, in metres, for a compliance boundary for both public and occupational exposure, are shown in Table 4.

The compliance boundary is defined as a cylinder around the antenna, see figure below. The antenna is not located at the centre of the cylinder. Instead it is located almost at the edge, facing in towards the center of the cylinder. The distance between the antenna's rear and the edge of the cylinder is the "Distance behind antenna" in Table 4. The height of the cylinder is the antenna height plus a certain distance above and below the antenna.

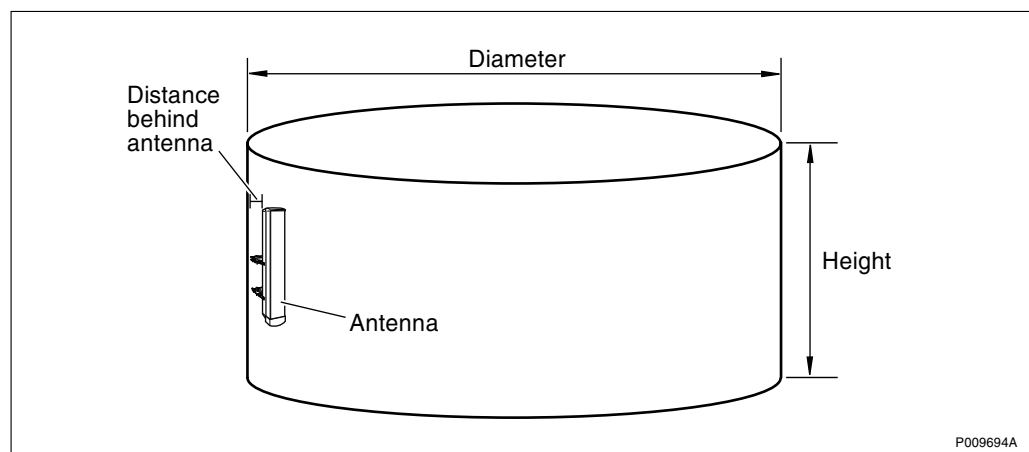

Figure 6 Compliance boundary cylinder

**Note:** Table 4 shows an example for a typical antenna. As the antenna field distributions will differ for different configurations and environments, complete calculations or measurements may be necessary in order to establish the compliance boundary for other configurations chosen by the customer. For further information on calculation methods, see:



Radio Site Installation Engineering  
Manual

EN/LZT 720 0069

*Table 4 Compliance boundary dimensions for the General Public (GP) and Occupational (O) exposure for typical configurations. Tilt: 0°.*

		Compliance distances (m) <sup>(1)</sup>					
		Diameter of cylinder		Height of cylinder		Distance behind antenna	
Frequency (MHz)	Configuration	GP	O	GP	O	GP	O
900	G:1x2, G:1x4	5	2	1.6	1.3	0.1	0.05
900	F:1x12	9	4	2.0	1.5	0.1	0.05
1800	G:1x2, G:1x4	4	1	1.6	1.6	0.1	0.05
1800	F:1x12	6	2	1.6	1.6	0.1	0.05

(2) *The numbers above are valid for these typical configurations and the specified antenna. Other installation configurations or antennas can result in different compliance distances.*

For characteristics of an antenna recommended for typical configurations of an RBS 2106, see *Table 5*.

*Table 5 Characteristics for a typical antenna (KRE 101 1916/1)*

Antenna specifications	X-pol macro RBS sector antenna
Antenna height	1.3 m
Half-power beam width	60 degrees
Antenna gain	14.5 dBi at 900 MHz, 17 dBi at 1800 MHz

The maximum power fed to the antenna, as a function of the number of transceiver units (TRUs) per antenna and the maximum power (including tolerances and transmission loss) per TRU, for RBS 2106 at 900 MHz and 1800 MHz, are given in *Table 6*.

Table 6 Maximum power to antenna for various RBS 2106 configurations

Frequency (MHz)	Configuration	No. TRUs per antenna	Maximum CDU output power <sup>(1)</sup> per TRU (dBm)/(W)	Maximum power into antenna <sup>(2)</sup> (dBm)/(W)
E-GSM 900	G:1x2	1	48.3 / 67.6	45.3 / 33.9
E-GSM 900	G:1x4	2	45 / 31.6	45.0 / 31.7
E-GSM 900	F:1x12	6	46 / 39.8	50.8 / 120
GSM 1800	G:1x2	1	46.8 / 47.9	43.8 / 24.0
GSM 1800	G:1x4	2	43.5 / 22.4	43.5 / 22.4
GSM 1800	F:1x12	6	43 / 20	47.8 / 60

(1) Including tolerance.

(2) Including 3 dB transmission loss.

## 4.4

### Materials

All Ericsson products fulfil legal, market and Ericsson requirements regarding:

- Fire resistance of material, components, wires and cables
- Declaration of materials
- Use of restricted materials
- Recycling

### Package Material

The package material is recyclable.

## 5

### Hardware Units

A high level of availability is achieved using strict functional modularity in a system of standardised Replaceable Units (RUs). A failed RU can easily be replaced by a new one.



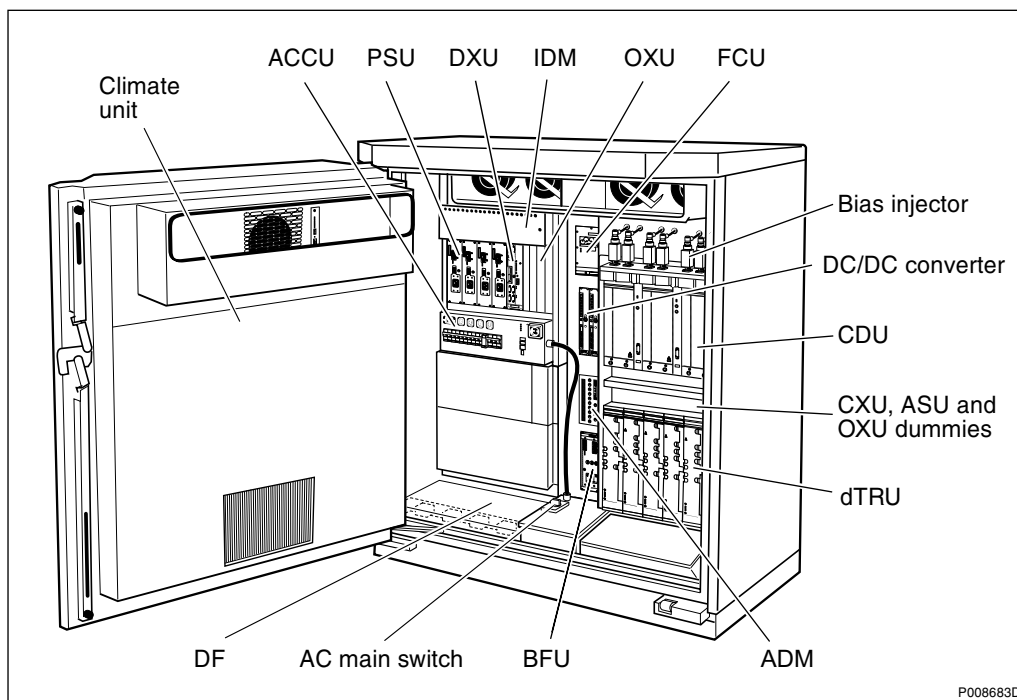

Figure 7 RBS 2106 overview

## 5.1 Standard Hardware Units

This section briefly describes the standard hardware units required for function, irrespective of configuration or frequency.

### ACCU – AC Connection Unit

The ACCU connects, disconnects, and distributes the incoming AC power supply to the PSUs and the climate unit. It consists of two parts: a Connection Unit and a Distribution Unit.

Number of units: 1

### BFU – Battery Fuse Unit

The Battery Fuse Unit (BFU) supervises connection or disconnection of the batteries. It can also be used to provide prioritized power supply, for example to the transmission equipment.

Each RBS cabinet will require its own BFU, regardless of battery back-up configuration.

Number of units: 1

## Climate Unit

The climate unit maintains the internal temperature and humidity inside the cabinet. The climate unit is mounted in the door of the cabinet.

Two types of climate unit are available:

- Combined Climate Unit. This unit provides both heating and refrigeration.
- Air-to-Air Heat Exchanger climate unit. This provides heating, and cooling through forced convection. It has no refrigerating capacity; thus the cabinet cannot be cooled to a temperature lower than that of the outside (ambient) temperature.

Number of units: 1

## CDU – Combining and Distributing Unit

The CDU is the interface between the transceivers and the antenna system. All signals are filtered before transmission and after reception by means of bandpass filters. The CDU allows several dTRUs to share antennas. There are a maximum of three CDUs in one RBS 2106.

The CDU combines transmitted signals from several transceivers, and distributes the received signal to several transceivers. The CDU is hardware-prepared to support EDGE. Two different CDU types are used in the RBS 2106 to support all configurations:

- **CDU-F** is a filter combiner intended for high capacity solutions.
- **CDU-G** can be configured either for high capacity or for high coverage. It is a combiner that can be used for synthesizer hopping.

Number of units: 1 – 3

## CXU – Configuration Switch Unit

The task of the CXU is to cross-connect the CDU and the dTRU in the receiver path. The CXU makes it possible to expand or reconfigure a cabinet without moving or replacing any RX cables.

The RX inputs/outputs on the dTRU and the CDU are placed in such positions that they minimise the amount of cable types for connecting the CXU with the dTRUs and the CDUs.

The CXU is software configured.

Number of units: 1

## **DF – Distribution Frame**

The Distribution Frame (DF) is a connection and overvoltage protection (OVP) device for external alarms and PCM links. The DF protects equipment inside the RBS from overvoltage and overcurrent which may occur in external lines. Examples of equipment requiring OVP include transmission lines, ESBs, external alarms and positioning devices (GPS and LMU).

Number of units: 1

## **DXU-21 – Distribution Switch Unit**

The DXU-21 is the central control unit for the RBS. It supports the interface to the BSC, and it collects and transmits the alarms. The DXU-21 controls the power and climate equipment for the RBS. It has a removable compact flashcard which makes it possible to replace a faulty DXU-21 without the need for loading RBS software from the BSC.

The DXU-21 is provided with four connections for transmission lines. It can handle 2 Mbit (E1) or 1.5 Mbit (T1) PCM links.

The DXU-21 has hardware support for EDGE on 12 TRXs.

Number of units: 1

## **dTRU – double Transceiver Unit**

The dTRU contains two TRXs for transmission and reception of two radio carriers.

It has a built-in combiner with the optional possibility of combining two TX signals into one TX output. It is also prepared for four-branch RX diversity for further improvements in sensitivity.

One version of the dTRU supports only GMSK and the other version supports both GMSK and EDGE.

Number of units: 1 – 6

## **FCU – Fan Control Unit**

The FCU is concerned with cooling RUs, not with controlling the general temperature or humidity conditions within the cabinet.

The FCU monitors the temperature sensors located on certain RUs and controls the speed of the four internal cabinet fans accordingly. The fans are positioned between the CDU subrack and the roof, giving a common suction area.

Number of units: 1

### **IDM – Internal Distribution Module**

The IDM is a panel for distributing the internal +24 V DC power to the various units. Each distribution circuit in the cabinet is connected to a circuit breaker in the IDM.

Number of units: 1

### **PSU – Power Supply Unit**

The PSU converts 120 – 250 V to regulated +24 V DC.

Number of units: 1 – 4

## **5.2 Optional Hardware Units**

This section describes the RBS 2106 optional hardware units.

### **ASU – Antenna Sharing Unit**

Antenna sharing is part of co-siting, that is, using another cabinet together with a GSM RBS 2106 cabinet in the same sector. The ASU allows a TDMA (or other) cabinet and a GSM RBS 2106 cabinet to share RX antennas.

Number of units: 0 – 1

### **ADM – Auxiliary Distribution Module**

The ADM handles distribution and fuse connection of system voltage (+24 V DC and -48 V DC) to the transport module (TM).

Number of units: 0 – 1

### **Battery Back-up**

Batteries can be installed inside the cabinet in either of the TM/BM spaces located to the left of the BFU. It is also possible to use an external source of battery supply via the DC filter; if this is done, internal batteries may not be used.

### **Bias injector**

The bias injectors are used to provide the TMA with DC power from the TMA-CM, over the RX/TX feeder cables. The bias injector is mounted between the antenna feeder and the CDU.

Number of units: 0 – 6

### **DC/DC Converter**

The DC/DC converter can supply -48 V DC power to transmission equipment in the TM compartment. It converts +24 V DC to -48 V DC.

Number of units: 0 – 2

### **ddTMA**

The ddTMA is to be mast-mounted and placed close to the antenna. It improves the receiver sensitivity. The ddTMA saves feeder cables by duplexing RX and TX signals to the same cable.

Number of units per cabinet: 0 – 6.

### **DXX – Digital Cross Connector**

Digital Cross Connect (DXX) is a plug-in unit which combines cross-connect, control and interface functions. It has four 2 Mbit/s interfaces complying with the G.703 standard. If the DXX option is used, it is located in an Optional Expansion Unit (OXU) position in the DXU/ PSU subrack.

Number of units: 0 – 1

### **OXU – Optional Expansion Unit**

The following Optional Expansion Unit (OXU) positions are available:

- Four spaces in the DXU/PSU subrack
- One 19-inch OXU position is available between the CXU and the dTRU subrack.

RUs which typically are located in the OXU slots include the DXX and the TMA-CM. The 19-inch position above the CXU is used for an Antenna Sharing Unit (ASU) in co-sited cabinets.

### **TM – Transport Module**

The Transport Module (TM) is a space in the cabinet reserved for transmission equipment.

### **TMA-CM – Tower Mounted Amplifier Control Module**

The TMA-CM is used to provide ddTMA with 15 V DC power through the bias injectors. It also identifies ddTMA faults and forwards this information to the alarm module in the RBS. If a TMA-CM is used, it is located in one of the four OXU positions in the DXU/PSU subrack.

Number of units: 0 – 2

## 6 Interfaces

In this section, all external and internal connections are listed, as well as the test interface and the operator interface.

All external connectors enter the cabinet through the bottom of the cabinet.

Internal connections, test interface and operator interface are located on some cabinet hardware units.

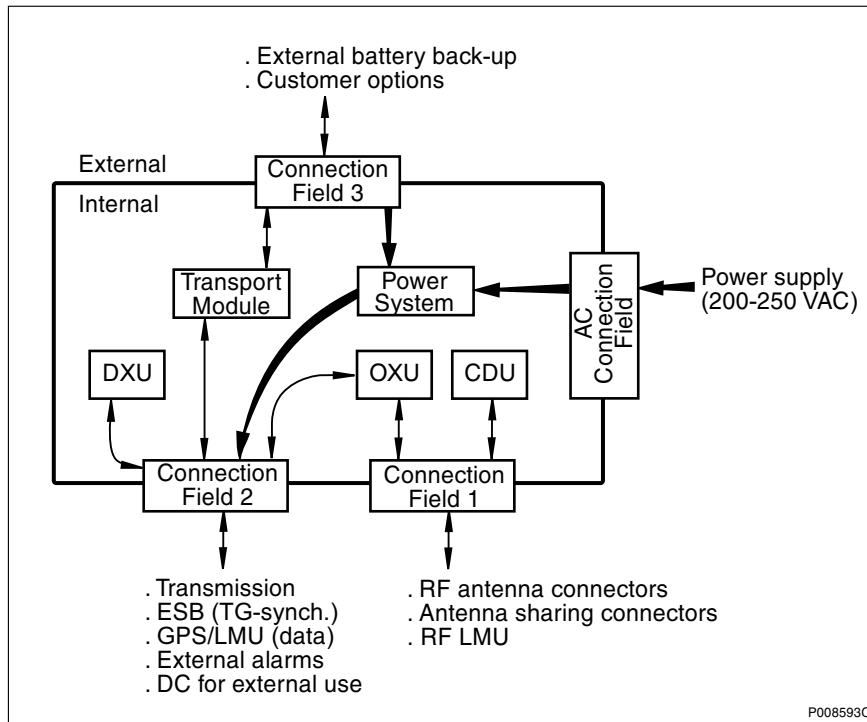

Figure 8 Internal and external interfaces

### 6.1 External connections

All external connectors enter the cabinet through the bottom of the cabinet. The approximate locations of the connection fields are shown in the figure below, to aid in planning cable inlet allowances.

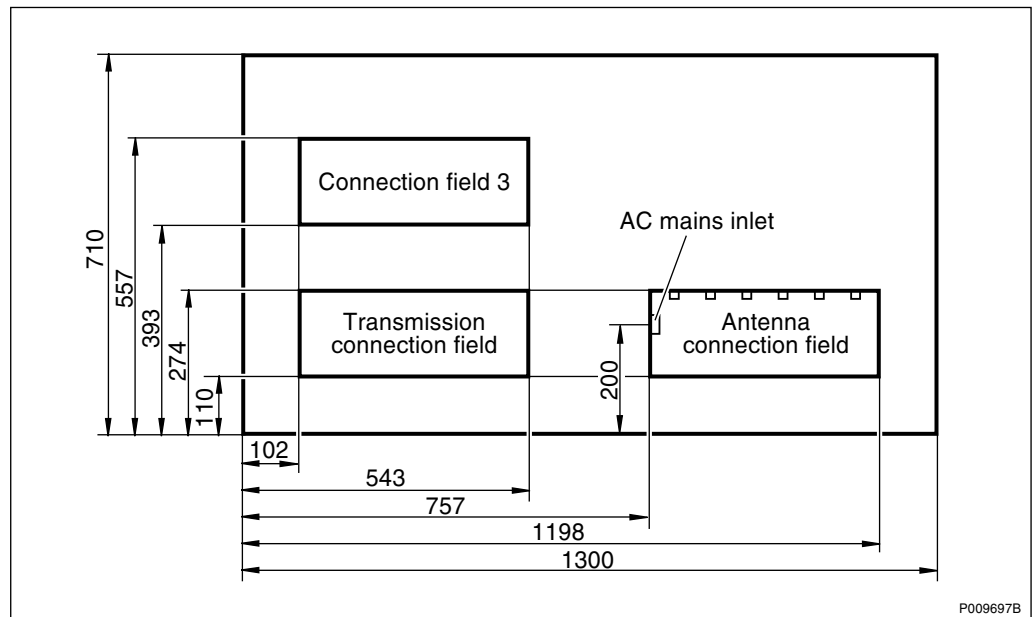

Figure 9 Cable inlet measurements

### Connections on Distribution Frame (DF)

The DF is a modular construction containing overvoltage arrestors for external alarms and OVP modules for PCM and ESB cables.

### Overvoltage Arrestors for External Alarms

All voltage arrestors, for example external alarms, have space for two alarms. The cable used should be single core, with a diameter of 0.3 – 0.8 mm.

*Table 7 Overvoltage arrestors*

<b>Alarm</b>	<b>Connector</b>
Alarm 1+	OVP 1, terminal 4
Alarm 1-	OVP 1, terminal 3
Alarm 2+	OVP 1, terminal 2
Alarm 2-	OVP 1, terminal 1
Alarm 3+	OVP 2, terminal 4
Alarm 3-	OVP 2, terminal 3
Alarm 4+	OVP 2, terminal 2
Alarm 4-	OVP 2, terminal 1
Alarm 5+	OVP 3, terminal 4
Alarm 5-	OVP 3, terminal 3
Alarm 6+	OVP 3, terminal 2
Alarm 6-	OVP 3, terminal 1
Alarm 7+	OVP 4, terminal 4
Alarm 7-	OVP 4, terminal 3
Alarm 8+	OVP 4, terminal 2
Alarm 8-	OVP 4, terminal 1

### **Antenna Connections**

The Antenna connectors are accessible from the antenna connection box in the bottom of the cabinet. The intake plate in the bottom of the cabinet is equipped with six antenna cable connectors.



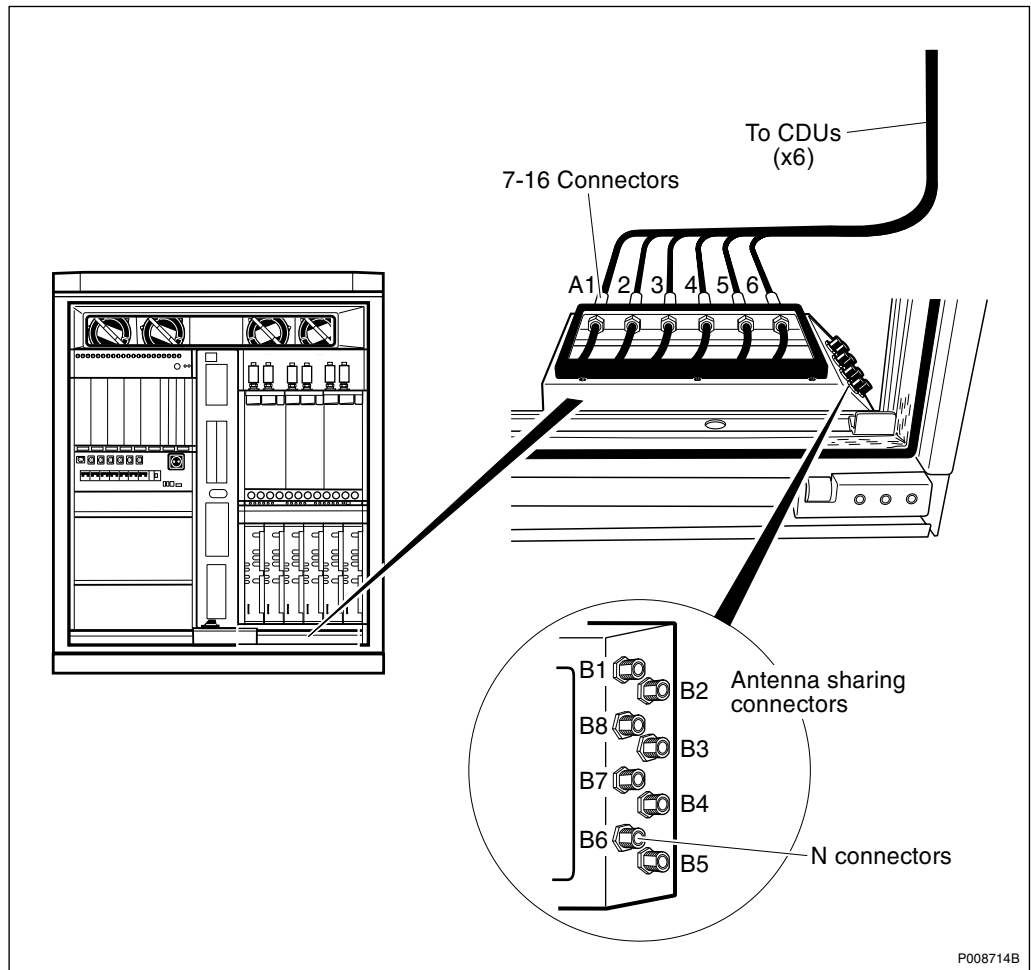

Figure 10 Antenna connections

Table 8 Antenna connections

Connection No.	Connection to	Type of connector
A1 – A6	Antenna	7/16" IEC 169 – 4
B1 – B6	Antenna sharing	N connector IEC 169-16
B7 – B8	RF LMU	N connector IEC 169-16

## Other External Connections

Table 9 External connections

Connection Location	Connection to	Type of connector
AC connection box	AC Mains connections	Screw terminal for wires 4 – 16 mm
ACCU	AC Service outlet	<ul style="list-style-type: none"> <li>IEC 83:1975 standard C 2b (Sweden, Germany and others)</li> <li>IEC 83:1975 standard B2, same as BS 1363:1984 standard 13A (UK)</li> <li>IEC 83:1975 standard A5-15 (USA)</li> </ul>
Reference Earth	Earthing connection	M8 screw, 50 mm <sup>2</sup> stranded copper wire

### External connections to TM

Optical fiber and MiniLink radio cables are connected to the TM via connection field 3. Twisted pair cables connect to the TM via the OVP.

### Transport Network to TM

The external line from the transport network interfaces to the transport module. The type and impedance of the connector may differ from operator to operator.

## 6.2 Test interface

The RBS 2106 is equipped with test interfaces for connection of external equipment.

13 MHz reference signal	The 13 MHz reference signal used to synchronise test equipment is located on the DXU.
System voltage test	The system voltage test port provides access to the system voltage (+24 V DC). It is located on the IDM.
OMT	The OMT interface is located on the front of the DXU.

## 6.3 Operator Interface

The Man-Machine Interface (MMI) in the RBS 2106 is comprised of indicators and buttons located on the hardware units in the cabinet.

<b>Indicators</b>	<b>Description</b>
Bat disconnect	Battery disconnected
Battery mode	Indicates that the RBS is running on battery
BS fault	One or more faults are detected on RUs in the RBS
External alarm	One or more supervised external alarms are active
Fault	Fault detected and localised to the RU
Local mode	The RU is in local mode
Operational	The RU is operational
Fan Fault	A fan is faulty
EPC Bus Fault	Communication to superior RU is lost
RF off	No RF antennas
TMA 1 – 6	The TMA is operational
Transmission OK	Signal and frame sync OK
H/E internal CCU	A fan is faulty
H/E external fan fault (Y)	A fan is faulty
Active cooler fan fault (Y)	A fan is faulty
Active cooler fault (Y)	The cooler is faulty
Heater fault (Y)	The heater is faulty
Power fault	AC or DC power is missing in the climate unit

## Buttons

Table 10 Switches and circuit breakers

Switch	Position	Function
DXU reset	DXU	Resets the DXU and all subunits
Local/remote	DXU, dTRU	Changes mode between local and remote
TRU reset	DTRU	Resets the dTRU
Battery disconnected	BFU	Disconnects the battery supply
DC out	BFU	Automatic CB for DC out
DC out 1	BFU	Automatic CB for DC out 1
DC out 2	BFU	Automatic CB for DC out 2
EC	BFU	Automatic CB for EC supply
Mains switch	ACCU	Mains switch for power supply
TMA/no TMA	ASU	Switch for TMA

## Barcode

The barcode for product identification is readable without disturbing the RBS function.

## 7 Power System

This section provides information on the power system of the RBS 2106.

The main characteristics of the RBS 2106 power supply are:

- Only alternating current (AC) mains supply is used.
- Battery back-up may be internal or external (but not both at the same time).
- The socket of the AC service outlet is available in three variants according to national standards.

An overview of the power distribution system within the RBS 2106 is given in the figure below:

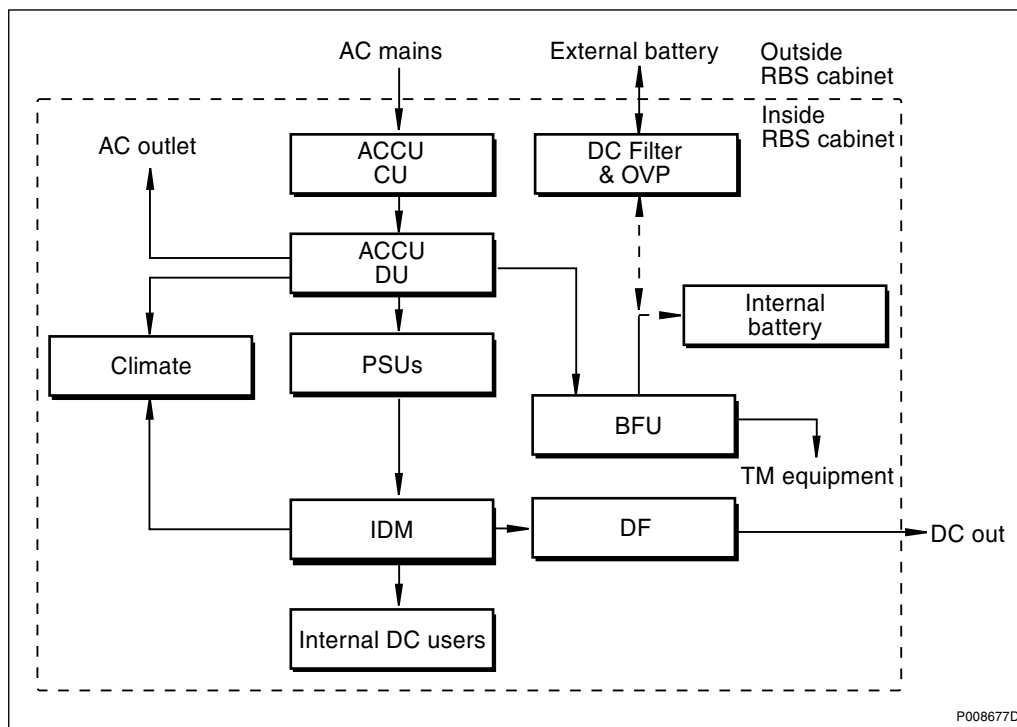

Figure 11 Power system

## 7.1 Power Supply

### AC Mains Supply Voltage

Single-phase, two-phase or three-phase AC may be used.

Table 11 Power parameters

Nominal voltage	200 – 250 V AC
Operating voltage	180 – 275 V AC
Nominal frequency	50 – 60 Hz
Operating frequency	45 – 65 Hz
Maximum inrush current (total, all phases)	60 A for 10 ms (typical duration)
Maximum ground leakage current	50 mA
PSU capacity	4 x 1200 W (4800 W total)
BFU	1 x 200 A

### External Earth Fault Circuit Breakers

If external earth fault circuit (ground fault) breakers are used, then the recommended minimum trip value is 100 mA.

## Mains Fuses

Table 12 Mains fuses recommendation

Minimum for Safe Function	Recommended for Maximum Selectivity	Maximum Allowed Fuse Rating
25 A/40 A <sup>(1)</sup>	32 A/50 A <sup>(1)</sup>	63 A

(1) Three-phase/Single phase

## 7.2 Battery Back-up

Battery back-up is used to power the site during mains failure and also to protect the site from short-term interruptions in the mains supply.

### Internal Battery Back-up

The following battery back-up levels can be achieved in the cabinet itself:

- Full: one hour back-up time
- Half: half an hour back-up time

If no TM equipment is used, it is possible to add additional batteries in the TMA compartment. The back-up time will then be enhanced by 100%.

### External Battery Back-up

Two external battery back-up alternatives are supplied by Ericsson: the BBS or the battery frame. Both are connected via the DC Filter.

## 7.3 Output Power

The RBS can supply the TM with power according to the table below:

Table 13 Output power

-48 V DC	2 x 200 W
+24 V DC	2 x 250 W
-48 V DC and +24 V DC	200 W + 250 W

**Note:** Power to the transport module can be distributed to up to 10 internal users via the optional RU/ADM.

## 7.4 Power Consumption

Table 14 Power consumption

Climate system	Power consumption, input voltage >200 V AC	Power consumption, input voltage < 120 V AC
Heater plus forced-air cooling only	5948 W	6049 W
Heater plus refrigerated cooling	6588 W	6049 W

## 8 Transmission

The RBS 2106 supports two transmission standards:

- T1 1.5 Mbit/s, 100  $\Omega$ , with internal synchronisation
- E1 2 Mbit/s, 75  $\Omega$ , with PCM synchronisation
- E1 2 Mbit/s, 120  $\Omega$ , with PCM synchronisation

## 9 External Alarms

The RBS 2106 supports a maximum of 16 external alarms. The external alarm device can set the alarm by either an open or a closed condition.

The alarm device connected to the screw terminals should be isolated relay contacts. A closed contact (logic zero) is required to be below 2 k $\Omega$ , and an open contact (logic one) above 100 k $\Omega$ . The current through a closed 0  $\Omega$  contact is 1.2 mA. The voltage between terminals with an open contact is 24 V DC.

The external alarms are defined at the installation. They are defined by using the Operation and Maintenance Terminal (OMT) or from the BSC using the remote OMT.

## 10 Standards, Regulations and Dependability

In this section a brief overview over standards, type approval and electromagnetic compatibility are stated.

### 10.1 Safety Standards

In accordance to the market requirements, the RBS 2106 complies with the following product safety standards:

- 73/23/EEC Low voltage directive

- IP 55 according to IEC 60529
- EN 60950 / IEC 60950
- EN 60215 / IEC 60215
- UL 1950
- CSA 22.2 No. 950

## 10.2 Other Standards and Regulations

### Marking

The product is marked with signs to show compliance with product safety standards.

### Type Approval Standards

The RBS complies with the European Community and the North America market requirements regarding radio performance. The product has the CE and FCC signs to show compliance to the legal requirements in respective region.

### Electromagnetic Compatibility (EMC)

The RBS complies with the European Community and the North America market requirements regarding EMC. The product has the CE and FCC signs to show compliance to the legal requirements in respective region.

### Dependability

The RBS 2106 is designed for a technical lifetime of 25 years (24-hour operation). The following preventive maintenance conditions must be fulfilled to guarantee the availability of the RBS:

Fans	The fans must be inspected (cleaned if necessary) every year. The lifetime is estimated to at least 5 years.
The Climate Unit	The climate unit must be regularly inspected and cleaned (interval is approximately one year, but depends on the environmental conditions at the site).
Batteries	The batteries must be regularly inspected every year (oxide on the pole terminals). The batteries should be replaced according to the recommendations of the battery supplier.



## **Vandal Resistance**

The RBS 2106 fulfils Ericsson's requirements for vandal resistance.

Ericsson AB  
SE-164 80 Stockholm  
Sweden

[implementation.GSMsupport@era.ericsson.se](mailto:implementation.GSMsupport@era.ericsson.se)

Due to continued progress in methodology, design and manufacturing,  
the contents of this document are subject to change without notice.

© Ericsson AB

# RBS 2206

## Radio Base Station

### Product Description

The RBS 2206, a member of the RBS 2000 family, is a 12-TRX radio base station for indoor applications. This cabinet covers the same floor area as the RBS 2202, its predecessor, and boasts double capacity.

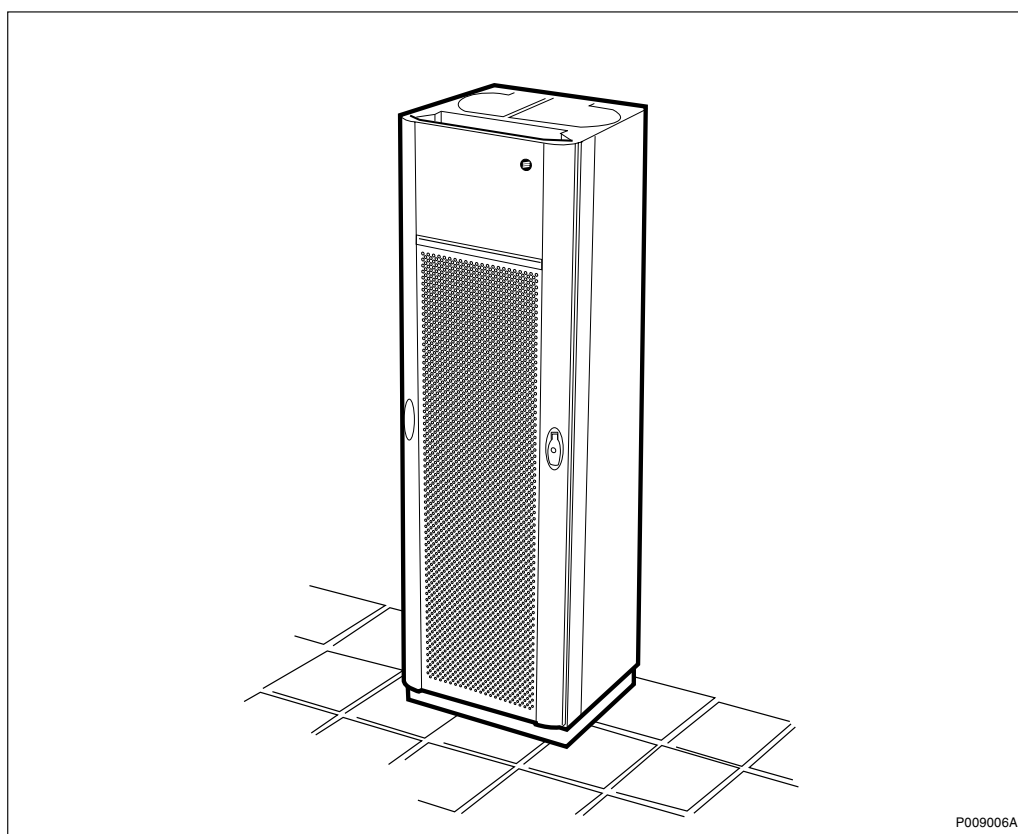

## Contents

<b>1</b>	<b>Product Overview</b>	<b>3</b>
1.1	Main Features	3
1.2	Variants	3
1.3	Optional Equipment	4
<b>2</b>	<b>Dimensions</b>	<b>4</b>
<b>3</b>	<b>Space Requirements</b>	<b>5</b>
<b>4</b>	<b>Environment</b>	<b>7</b>
4.1	Operating Environment	7
4.2	Environmental Impact	8
4.3	Compliance Distances for Electromagnetic Exposure	8
4.4	Materials	10
<b>5</b>	<b>Hardware Units</b>	<b>11</b>
5.1	Standard Hardware Units	11
5.2	Optional Hardware Units	13
<b>6</b>	<b>Interfaces</b>	<b>15</b>
6.1	External Connections	16
6.2	Test Interface	17
6.3	Operator Interface	17
<b>7</b>	<b>Power System</b>	<b>18</b>
7.1	AC mains supply voltage	18
7.2	+24 V DC Supply Voltage	20
7.3	–(48 – 60) V DC Supply Voltage	20
7.4	Battery Back-up	21
7.5	Power Consumption	21
<b>8</b>	<b>Transmission</b>	<b>21</b>
<b>9</b>	<b>Alarms</b>	<b>22</b>
<b>10</b>	<b>Standards, Regulations and Dependability</b>	<b>23</b>
10.1	Safety Standards	23
10.2	Other Standards and Regulations	23

# 1 Product Overview

The RBS 2206 is a high-capacity indoor base station. It is used for indoor applications, with up to six double Transceiver Units (dTRU). The RBS 2206 is designed to be transported as a fully-assembled cabinet to the site. All units in the cabinet are easily accessible from the front of the cabinet, which means that the cabinets can be mounted side by side with their backs against a wall.

## 1.1 Main Features

The RBS 2206 can support the following features:

- 1, 2 or 3 sectors in one cabinet using CDU-F or CDU-G
- Co-siting (antenna sharing) with TDMA or WCDMA systems
- Discontinuous transmission/reception
- Duplex filters
- Dynamic power regulation
- Encryption/ciphering
- EDGE (hardware prepared)
- Expansion by TG-synchronisation
- External alarms
- Frequency hopping
- Positioning with GPS/LMU
- Radio configurations supported on 800, 900, 1800 and 1900 MHz
- Receiver diversity
- Transmission Interface: The following transport network interface alternatives exist:
  - T1 1.5 Mbit/s, 100  $\Omega$ , with internal synchronisation
  - E1 2 Mbit/s, 75  $\Omega$ , with PCM synchronisation
  - E1 2 Mbit/s, 120  $\Omega$ , with PCM synchronisation
- Wide range power input 120 – 250 V AC

## 1.2 Variants

There are three RBS 2206 cabinet versions:

- –48 to –60 V DC
- 120 – 250 V AC/ +24 V DC, 50/60 Hz

- +24 V DC (without PSUs)

### 1.3 Optional Equipment

The equipment listed below is available, but is not necessary for basic functionality.

- ASU
- Battery back-up
- Bias injectors
- DM
- dual duplex Tower Mounted Amplifier (ddTMA)

**Note:** For GSM 1800 and GSM 1900 the ddTMA is mandatory equipment.

- DXX
- ESB
- Mini-DXC
- OVP
- TMA-CM
- Transmission Adapter (TA)

## 2 Dimensions

This section describes the physical characteristics of the RBS 2206; size and weight, as well as colour.

*Table 1 Size and weight*

Unit	Weight
RBS cabinet (fully equipped including base frame)	230 kg (507 lbs.)
Base frame	12 kg (26 lbs.)

*Table 2 Colour*

Colour	Reference No.
Grey	NCS 1002-R

Surface quality according to Ericsson standard class A3/B6.

### 3 Space Requirements

In the following sections the required space and recommended floor layout is indicated.

#### Free Space above the RBS Cabinet

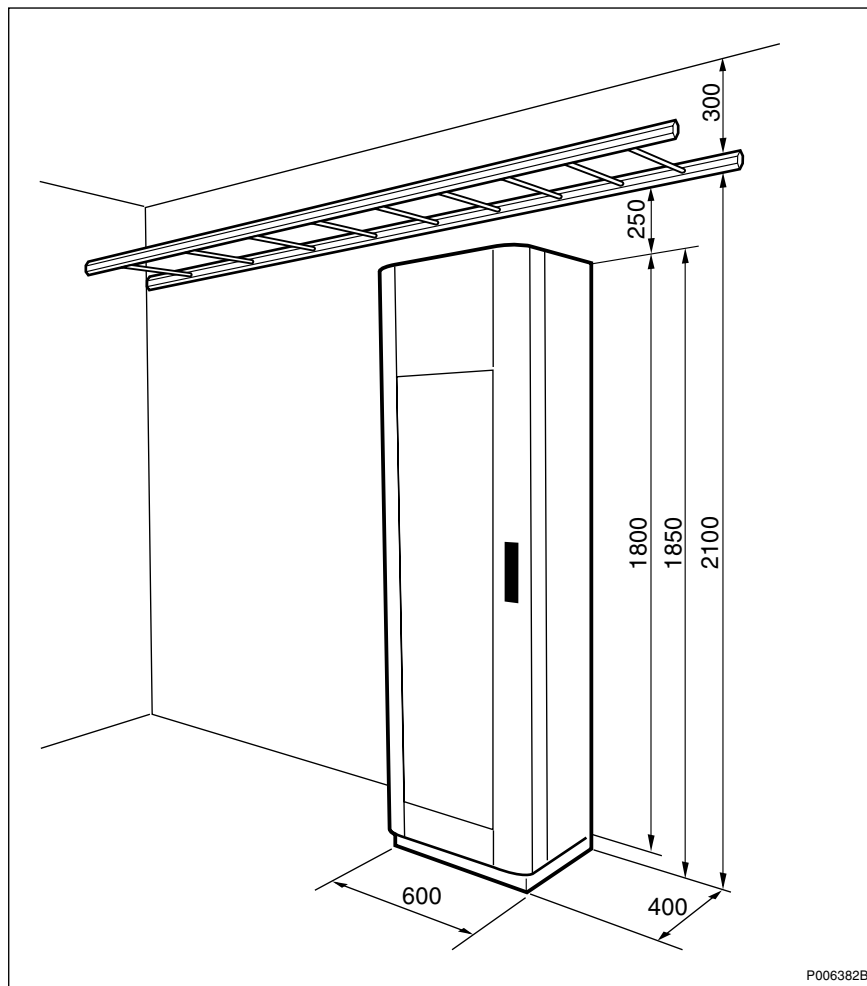
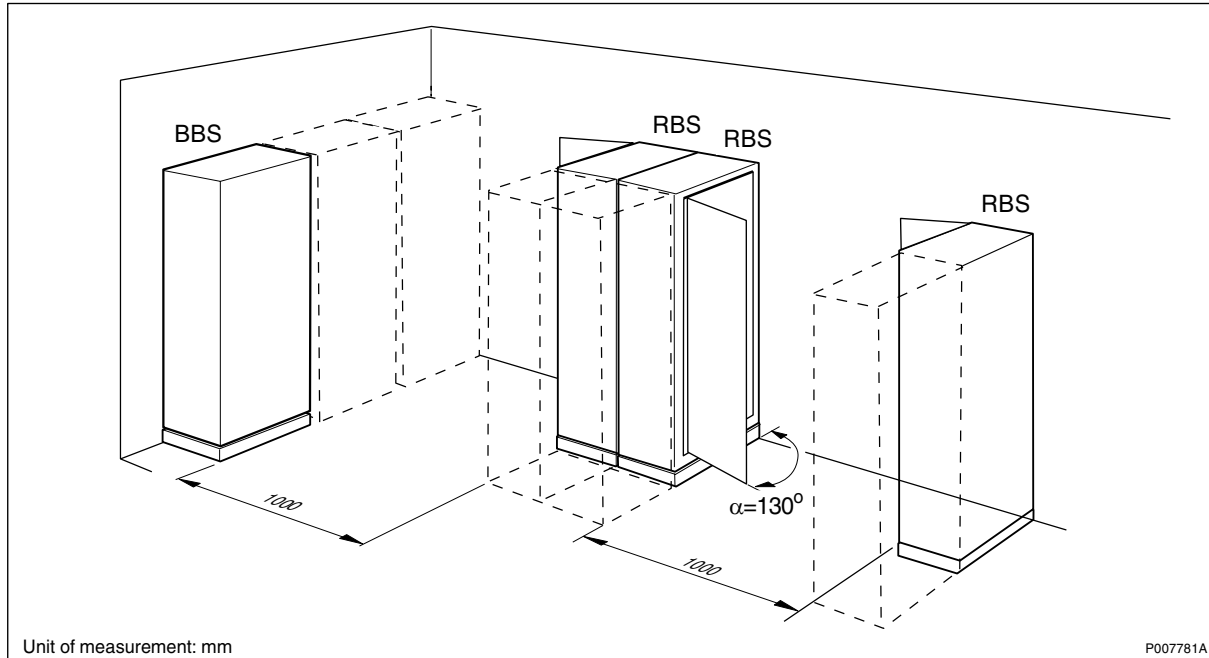

*Figure 1 RBS 2206, free space above the cabinet*

The recommended distance between the cabinet and cable ladder is 250 mm. A shorter distance makes it difficult to exchange fans and may restrict the air flow. A space of 300 mm is recommended above the cable ladder to make cable installation work easier.

The door projects 50 mm in front of the cabinet.

## Layout for RBS Cabinets



*Figure 2 Floor layout and space requirements*

The RBS cabinets and BBS racks are mounted on the floor, and may be positioned against a wall, back to back, or free standing without contact with other cabinets.

Expansion cabinets and racks can be positioned to the left or to the right of the master cabinet. However, expansion to the right is recommended in order to follow the same standard globally.

A distance of 1000 mm in front of the cabinets and racks for maintenance work is recommended.

**Note:** Space for future expansion must be considered as indicated in the dotted line in the figure above.

## Earthquake Requirements

If the RBS cabinet shall fulfill the requirements for earthquake protection, the space between wall and cabinet is to be at least 100 mm and between cabinets at least 150 mm.



### Footprint

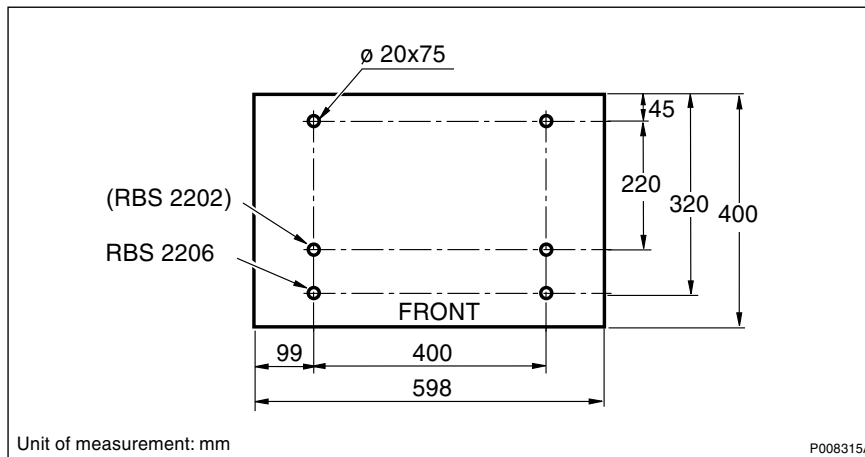

Figure 3 Hole pattern overview

The RBS 2206 has the same footprint as the RBS 2202 cabinet. The base frame is used as a template to mark new holes. If an RBS 2202 is being replaced by an RBS 2206, the holes for the old cabinet can be used for the new cabinet.

## 4 Environment

The RBS 2206 is designed to operate within limits stated for climatic requirements and also to have a limited effect on the environment.

### 4.1 Operating Environment

The climatic requirements the RBS 2206 has on the site are shown in the table below.

Table 3 Climatic requirements

Environmental Parameters	Normal Operation <sup>(1)</sup>	Safe Function	Non-destructive Conditions <sup>(2)</sup>
Temperature	+5 to +40 C°	0 to +45 C°	-10 to +55 C°
Relative Humidity	5 – 85%	5 – 90%	5 – 90%

- (1) Normal operation describe the environmental conditions where all units function as specified.
- (2) Non-destructive conditions describe environmental stress above the limits for normal conditions with no function guaranteed and unspecified degradation. When the environmental stress has dropped to normal conditions, restoring full RBS performance requires no manual intervention on site. Non-destructive conditions refer to a period of maximum 96 consecutive hours, and a total of maximum 5.5 days in a three-year period.

## Ground Vibrations

The RBS 2206 is tested to withstand random vibrations of up to 0.2 m<sup>2</sup>/s<sup>2</sup>. It is also tested for single shocks up to 40 m/s<sup>2</sup>. The cabinet is tested for seismic exposure with a test frequency of 1 – 35 Hz. Maximum test level of the Required Response Spectrum (RRS) is 50 m/s<sup>2</sup> within 2 – 5 Hz. The shape of RRS is defined by the ETSI standard.

## Levelling

For cabinet levelling purpose, the floor must be level to within ±3 mm/2000 mm and the floor gradient be within ±0.1°.

## 4.2 Environmental Impact

This section describes the effects that the cabinet has on the environment.

### Heat Dissipation

The RBS 2206 generates an average heat load of 1500 W. The exact figure is dependent upon configuration, equipment and site-specific conditions.

## 4.3 Compliance Distances for Electromagnetic Exposure

The compliance distance is the minimum separation that should be kept between an antenna and a person to ensure that RF exposure limits are not exceeded.

Ericsson has performed a near-field RF exposure assessment of typical configurations of the RBS 2206 with a recommended antenna. The resulting dimensions, in metres, for a compliance boundary for both general public and occupational exposure are *shown in Table 4*.

The compliance boundary is defined as a cylinder around the antenna, see *figure below*. The antenna is not located at the centre of the cylinder. Instead it is located almost at the edge, facing in towards the center of the cylinder. The distance between the antenna's rear and the edge of the cylinder is the "Distance behind antenna". The height of the cylinder is the antenna height plus a certain distance above and below the antenna.

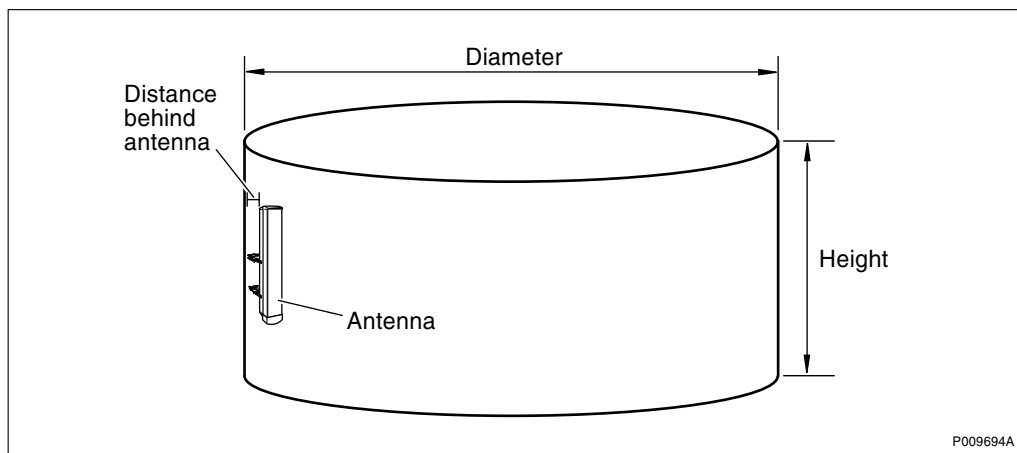

Figure 4 Compliance boundary cylinder

**Note:** Table 4 shows an example for a typical antenna. As the antenna field distributions will differ for different configurations and environments, complete calculations or measurements may be necessary in order to establish the compliance boundary for other configurations chosen by the customer. For further information on calculation methods, see:



Radio Site Installation Engineering Manual

EN/LZT 720 0069

Table 4 Compliance boundary dimensions for the General Public (GP) and Occupational (O) exposure for typical configurations. Tilt: 0°.

		Compliance distances (m) <sup>(1)</sup>					
		Diameter of cylinder		Height of cylinder		Distance behind antenna	
Frequency (MHz)	Configuration	GP	O	GP	O	GP	O
900	G:1x2, G:1x4	5	2	1.6	1.3	0.1	0.05
900	F:1x12	9	4	2.0	1.5	0.1	0.05
1800	G:1x2, G:1x4	4	1	1.6	1.6	0.1	0.05
1800	F:1x12	6	2	1.6	1.6	0.1	0.05

(1) The numbers above are valid for these typical configurations and the specified antenna. Other installation configurations or antennas can result in different compliance distances.

For characteristics of an antenna recommended for typical configurations of an RBS 2206, see Table 5.

*Table 5 Characteristics for a typical antenna (KRE 101 1916/1)*

Antenna specifications	X-pol macro RBS sector antenna
Antenna height	1.3 m
Half-power beam width	60 degrees
Antenna gain	14.5 dBi at 900 MHz, 17 dBi at 1800 MHz

The maximum power fed to the antenna, as a function of the number of transceiver units (TRUs) per antenna and the maximum power (including tolerances and transmission loss) per TRU, for RBS 2206 at 900 MHz and 1800 MHz, are given in *Table 6*.

*Table 6 Maximum power to antenna for various RBS 2206 configurations*

Frequency (MHz)	Configuration	No. TRUs per antenna	Maximum CDU output power <sup>(1)</sup> per TRU (dBm)/(W)	Maximum power into antenna <sup>(2)</sup> (dBm)/(W)
E-GSM 900	G:1x2	1	48.3 / 67.6	45.3 / 33.9
E-GSM 900	G:1x4	2	45 / 31.6	45.0 / 31.7
E-GSM 900	F:1x12	6	46 / 39.8	50.8 / 120
GSM 1800	G:1x2	1	46.8 / 47.9	43.8 / 24.0
GSM 1800	G:1x4	2	43.5 / 22.4	43.5 / 22.4
GSM 1800	F:1x12	6	43 / 20	47.8 / 60

(1) Including tolerance.

(2) Including 3 dB transmission loss.

## 4.4

### Materials

All Ericsson products fulfil the legal, market and Ericsson requirements regarding:

- Fire resistance of material, components, wires and cables
- Declaration of materials
- Use of restricted material
- Recycling

### Package Material

The package material is recyclable.

## 5 Hardware Units

A high level of availability is achieved using strict functional modularity with a system of standardised units. A failed unit can easily be replaced by a new one. It is possible to add up to three new units in the PSU/DXU magazine.

The RBS 2206 cabinet contains the radio equipment, power supply and the climate equipment (fans). All required transmission equipment and battery back-up must be housed outside the cabinet.

Outside equipment is listed under optional units. Not all HW units are covered in this section, only those directly related to RBS.

### 5.1 Standard Hardware Units

This section briefly describes the standard hardware units required for functionality, irrespective of configuration or frequency.

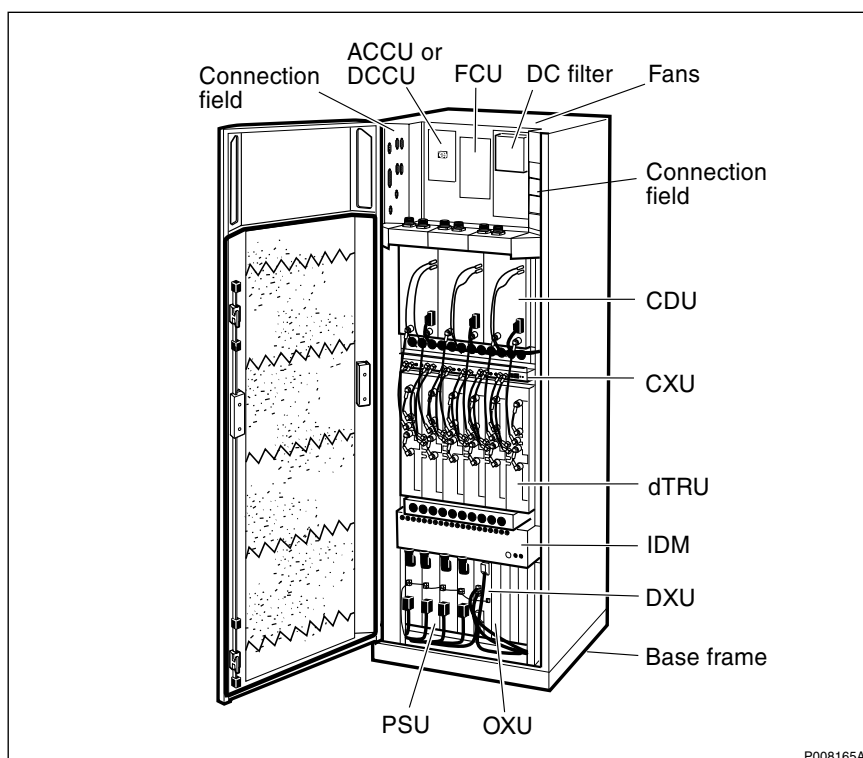

Figure 5 Standard hardware units

#### ACCU – AC Connection Unit

The ACCU handles distribution and connection/disconnection of the incoming AC power supply voltages to the PSUs. Connection/disconnection is performed by the main switch. The unit also contains filter equipment.

Number of units: 1

### **CDU – Combining and Distribution Unit**

The CDU is the interface between the transceivers and the antenna system. All signals are filtered before transmission and after reception by means of bandpass filters. The CDU allows several dTRUs to share antennas. There are a maximum of three CDUs in one RBS 2206.

The CDU combines transmitted signals from several transceivers, and distributes the received signal to several transceivers. The CDU is hardware-prepared to support EDGE. Two different CDU types are used in the RBS 2206 to support all configurations:

- **CDU-F** is a filter combiner intended for high capacity solutions.
- **CDU-G** can be configured either for high capacity or for high coverage. It is a combiner that can be used for synthesizer hopping.

Number of units: 1 – 3

### **CXU – Configuration Switch Unit**

The CXU cross-connects the CDU and the dTRU in the receiver path. The CXU makes it possible to expand or reconfigure a cabinet without moving or replacing any RX cables. The RX inputs/outputs on the dTRU and the CDU are placed in such positions that they minimize the amount of cable types for connecting the CXU with the dTRUs and the CDUs. The CXU is configured by means of software.

Number of units: 1

### **DCCU – DC Connection Unit**

The DCCU handles distribution and connection/disconnection of the incoming DC power supply voltages to the PSUs. Connection/disconnection is performed by the main switch. The unit also contains filter equipment.

### **dTRU – double Transceiver Unit**

The dTRU contains two TRXs for transmission and reception of two radio carriers. It has a built-in combiner with the optional possibility of combining two TX signals into one TX output. It is also prepared for four-branch RX diversity for further improvements in sensitivity. This version of the dTRU supports only GMSK and a later version will support both GMSK and EDGE.

Number of units: 1 – 6

### **DXU-21 – Distribution Switch Unit**

The DXU is the central control unit for the RBS. It supports the interface to the BSC, and it collects and transmits alarms. The DXU controls the power and

climate equipment for the RBS. It has a removable compact flashcard which makes it possible to replace a faulty DXU without the need for loading RBS software from the BSC. The DXU is also provided with four connections for transmission lines. It can handle both 2 Mbit (E1) and 1.5 Mbit (T1) PCM links. The DXU has hardware support for EDGE on 12 TRXs.

Number of units: 1

### **FCU – Fan Control Unit**

The FCU controls the four fans in the cooling system by regulating fan speed. The FCU is controlled by the DXU.

Number of units: 1

### **IDM – Internal Distribution Module**

The IDM is a panel for distributing the internal +24 V DC power to the various units. Each distribution circuit in the cabinet is connected to a circuit breaker in the IDM.

Number of units: 1

### **PSU – Power Supply Units**

The PSUs are available in two versions, PSU AC for connection to AC mains, or PSU DC for connection to -48 or -60 V DC power supply. The PSU AC converts 120 - 250 V to regulated +24 V DC. The PSU DC converts -(48 – 60) V DC to regulated +24 V DC.

Number of units: 0 – 4

### **DC Filter**

The DC filter unit is the interface for +24 V DC power supply or battery back-up.

Number of units: 1

## **5.2 Optional Hardware Units**

This section describes the optional RBS 2206 Hardware units.

### **ASU – Antenna Sharing Unit**

The ASU is part of co-siting, that is, using another cabinet together with a GSM RBS 2206 cabinet in the same sector. The ASU allows a TDMA (or other) cabinet and a GSM RBS 2206 cabinet to share RX antennas.

Number of units: 0 – 1

### **Bias injector**

The bias injector is used to provide the ddTMA with DC power, from the TMA-CM, over the RX/TX feeder cables. Six bias injectors can be connected to one TMA-CM. The BIAS-IC is mounted outside the cabinet, as close to the RF output as possible.

Number of units: 0 – 6

### **BBS**

The RBS 2206 can be provided with battery back-up from an external cabinet, either a BBS 2000 or a BBS 2202.

### **ddTMA – dual duplex Tower Mounted Amplifier**

The ddTMA is to be mast-mounted and placed close to the antenna. It improves the receiver sensitivity. The ddTMA saves feeder cables by duplexing RX and TX signals to the same cable.

Number of units: 0 – 6

### **DXX – Digital Cross Connector**

A 1 or 2-card DXX plug-in unit that is a digital cross-connector. The one card version has four G.703/G.704 ports. The 2-card version has four G.703/G.704 ports and one slot for two to four additional interfaces that can be G.703/G.704 ports, HDSL, LTE or optical fibre. It is installed in the OXU.

Number of units: 0 – 1

### **Mini-DXC**

A cross-connect unit that provides five G.703/G.704 ports. It is installed in the OXU.

Number of units: 0 – 1

### **OXU – Optional Expansion Unit**

There are four positions available for optional RUs in the DXU/PSU subrack, for example for TMA-CM and DXX. One 19-inch OXU-position is also available between the CXU and the dTRU subrack.

Number of units: 0 – 1



## TMA-CM – Tower Mounted Amplifier - Control Module

The Control Module is used to provide up to six ddTMAs with 15 V DC power through the bias injector. It is also used to identify TMA faults and forward this information to the alarm module in the RBS. The TMA-CM is mounted in an OXU position.

Number of units per cabinet: 0 – 2

## 6 Interfaces

In this section all external and internal connections are listed, as well as the test interface and the operator interface.

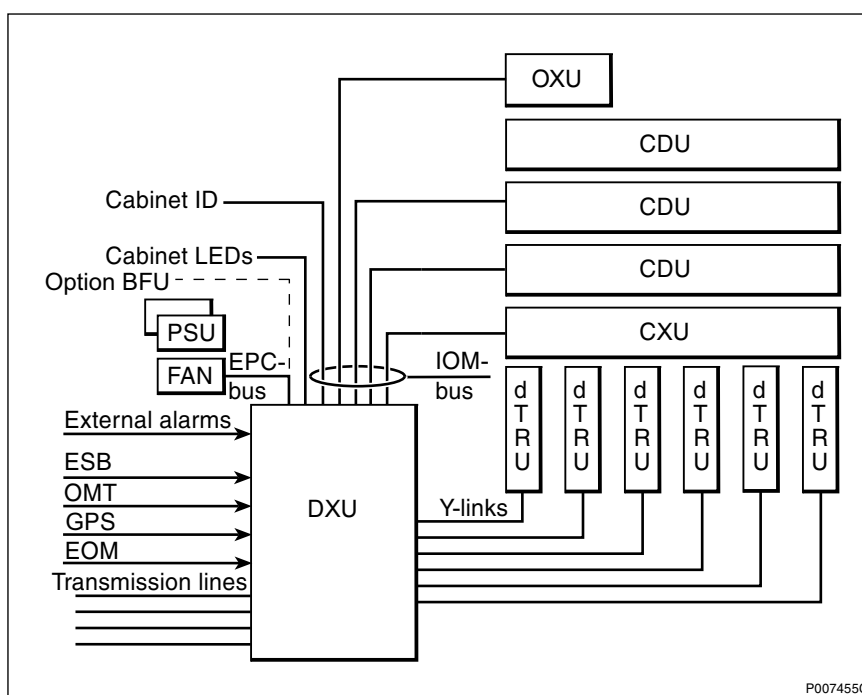

Figure 6 Block diagram showing internal power and signal paths

The connection field for external connectors is located at the top of the radio cabinet inside the door. Internal connections, the test interface and operator interface are located on some hardware units.

## 6.1 External Connections

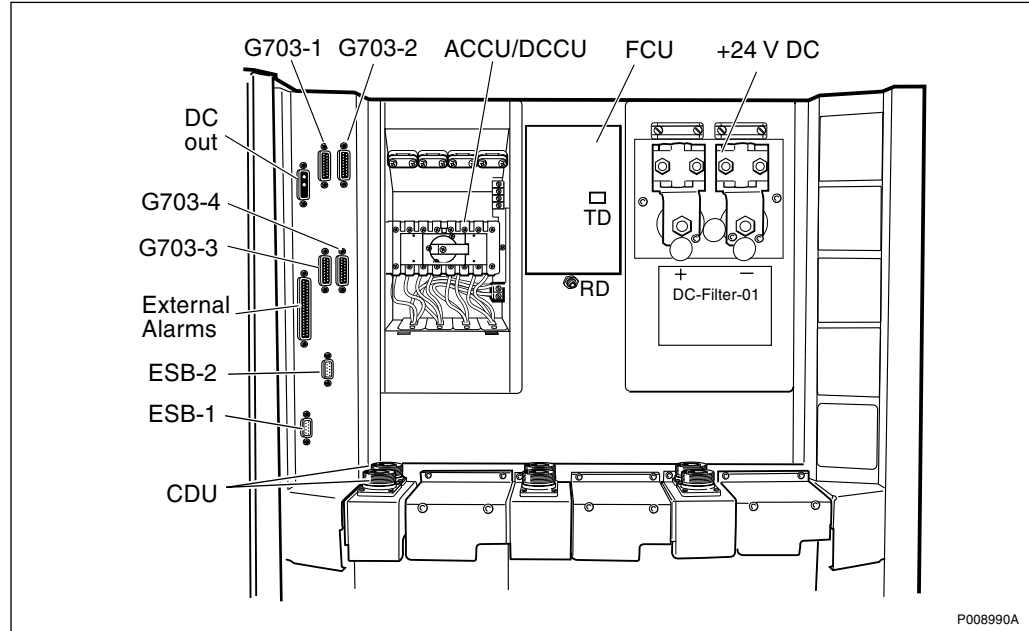

Figure 7 External connectors (shown here with CDU-F)

Antenna feeders are directly connected to the CDUs. If bias injectors are used, they are connected directly to the CDU and the antenna feeder is connected to the bias injector.

Table 7 External connections

Connection Name	Description	Connector Type
CDU	Feeder (and bias injector) connection to antennas	7-16 female connector
G703-1	Transmission Link 1	15-pin female, D-sub
G703-2	Transmission Link 2	15-pin female, D-sub
G703-3	Transmission Link 3	15-pin female, D-sub
G703-4	Transmission Link 4	15-pin female, D-sub
DC out	+24 V DC to external equipment	3-pole female, D-sub
External Alarms	External alarm inputs to DF	37-pin female, D-sub
ESB-1	ESB to co-sited cabinets	15-pin female, D-sub
ESB-2	ESB to co-sited cabinets	15-pin female, D-sub
FCU RD	Optical cable connector from the BBS	Opto connector
+24 V DC	DC filter + connection	Cable clamp
+24 V DC	DC filter - connection	Cable clamp
Earth	Earth stud M8 to main earth cable	M8 stud
ACCU 1 – 4	Mains connection to PSU-AC 1 – 4	Screw terminal

Connection Name	Description	Connector Type
DCCU 1 – 4	-48 V connection to PSU-DC 1 – 4	Screw terminal
ASU	Antenna sharing connections	SMA-connector

## 6.2 Test Interface

The test interface for the RBS 2206 is on the front panel of the DXU-21 unit.

The OMT port is used to connect the Operation and Maintenance Tool (OMT) to the RBS. A remote OMT can also be used from the BSC, which sends signals over the Abis interface.

## 6.3 Operator Interface

The Man Machine Interface (MMI) in the RBS 2206 is based on visual indicators and buttons located on the hardware units in the cabinet and on the cabinet door.

### Internal Indicators

AC Fault	One or more phases are faulty
Bat disconnect	Battery disconnected
ExternalBattery mode	Indicates that the RBS is running on battery
RBS fault	One or more faults are detected on RUs in the RBS
DC disconnected	Indicates that DC (system voltage) is disconnected
EOM bus fault	(For future use)
EPC bus fault	Indicates the state of the EPC bus
Ext alarm	One or more supervised external alarms are active
Fault	Fault detected and localised to the RU
Local mode	The RU is in local mode
Operational	The RU is operational
Test result	Indicates the result of tests
Transmission OK	Indicates state of transmission on ports A – D
RF off	RF not enabled

## External Indicators

The RBS 2206 has three indicators on the cabinet door:

RBS Fault	There is a fault in the RBS.
External Battery Mode	The RBS is operating on battery power.
External Alarm	There is at least one external alarm present in the RBS.

## Buttons

dTRU reset	Resets the dTRU
DXU reset	Resets all subunits
Local/remote mode	Changes RU mode to local or remote
Test call	Initiates the test operation function

## Barcode

The barcode for product identification is readable without disturbing the RBS function.

# 7 Power System

The power system of the RBS 2206 depends on the choice of power supply and may include a number of units outside the RBS.

The RBS 2206 can be connected either to AC mains supply voltage or to DC supply voltage.

*Table 8 Power supply voltage alternatives*

Nominal voltage	Range	PSU
120 – 250 V AC, 50 – 60 Hz	108 – 275 V AC, 45 – 65 Hz	PSU-AC
+24 V DC	+20.5 – +29 V DC	PSU not needed
-48 – -60 V DC	-40 – -72 V DC	PSU-DC

## 7.1 AC mains supply voltage

AC mains supply voltage is connected to the cabinet using four AC cables. If the power supply does not meet the AC power requirements, then filters and stabilisers must be installed to protect the equipment and ensure proper operation.

There are two ways to connect power to the base station. They are:

- Single phase line to neutral.
- Single phase line to line.

**Note:** When single phase line to line is used, each PSU requires two circuit breakers.

*Table 9 AC mains power requirements*

Voltage range for specified Performance (phase voltage)	120 – 250 V AC
Voltage range	108 – 275 V AC <sup>(1)</sup>
Frequency	45 – 65 Hz
Inrush current, max.	30 A (1 – 30 ms)
Maximum AC power	1.4 kW x 4
Non-destructive range	0 – 275 V AC
Overvoltage <20 ms	325 V <sup>(2)</sup>
Maximum ground leakage current	10 mA x 4

1) 90 – 108 V AC with reduced output power. 1000 W per PSU

2) Install external filter and stabiliser if not met.

## Mains Fuses

Table 10 Mains fuses recommendation

Minimum for Safe Function	Recommended for Maximum Selectivity	Maximum Allowed Fuse Rating
4x10 A <sup>(1)</sup> /16 A	4x16 A	4x20 A

1) For 200 – 250 V range only.

## External Earth Fault Circuit Breakers

If external earth fault (ground fault) circuit breakers are used, then the recommended minimum trip value is 100 mA.

## 7.2 +24 V DC Supply Voltage

Table 11 DC power requirements

Nominal	+24 V DC
Default	+27.2 V DC
Range	+20.5 – +29.0 V DC
Non-destructive range	+0 – +32 V DC
Inrush current	Max. 500 A (0.1 – 10 ms)

## Fuses

Table 12 +24 V DC fuse recommendation

Minimum for Safe Function	Recommended for Maximum Selectivity	Maximum Allowed Fuse Rating
1x160 A <sup>(1)</sup>	1x200 A	1x250 A

(1) May be used when no transmission and/or optional equipment is installed.

## 7.3 –(48 – 60) V DC Supply Voltage

Table 13 DC supply voltage requirements

Nominal	-48/-60 V DC
Range	-(40.0 – 72.0) V DC
Non-destructive range	+0 – (-80) V DC
Inrush current	200 A (0.1 – 5 ms)

## Fuses

Table 14 –(48 – 60) V DC fuse recommendation

Minimum for Safe Function	Recommended for Maximum Selectivity	Maximum Allowed Fuse Rating
4x32 A	4x35 A	4x40 A

### 7.4 Battery Back-up

Battery back-up is used to power the site during mains failure and to protect the site from short interruptions in the AC mains supply. It is available in an external cabinet.

It is possible to supply external transmission equipment from the battery cabinet. The transmission equipment is then provided with power supply longer than the RBS. In the event of mains failure, the batteries in the BBS 2000 or BBS 2202 will deliver the necessary power to the radio cabinet as well as to the transmission equipment, if used. This enables the radio system to continue operating during mains failure.

Battery back-up can be delivered for 1, 2, 4, 6 or 8 hours back-up time, depending on the chosen configuration of the RBS. The BBS can feed +24 V DC or -48 V DC to the TM equipment. The -48 V DC supply requires an internal DC/DC converter in the BBS. It is possible to share battery back-up between an RBS 2202 and an RBS 2206.

### 7.5 Power Consumption

The power consumption figures shown in the table below are for dimensioning cables and fuses. The figures in the table have been rounded off.

Table 15 Higher power consumption

RBS 2206 Cabinet (fully equipped)	Power Supply Voltage		
	120 –250 V AC	+24 V DC	-48 V DC
Maximum power consumption	3.2/5.7 kW <sup>(1)</sup>	2.7 kW	3.2 kW

(1) Power consumption during maximum battery charging

The RBS can supply transmission equipment with +24 V DC. The maximum power output is 250 W.

## 8 Transmission

The RBS 2206 is normally connected to a Distribution Frame (DF) for transmission (PCM lines). Four PCM cables are connected to the ports on the front of the DXU. The RBS 2206 supports two transmission standards:

- T1 1.5 Mbit/s, 100  $\Omega$  balanced PCM line.
- E1 2 Mbit/s, 75  $\Omega$  unbalanced (balun used), or 120  $\Omega$  balanced line.

### PCM Overvoltage Module

This module contains overvoltage protection for the PCM lines. If the PCM lines are terminated in equipment outside the RBS equipment room, these lines must be protected by overvoltage protectors (OVP) in the DF. Failure to do so might damage the DXU-21, if a voltage transient is transported along the cable. The RBS 2206 is designed for 100/120  $\Omega$  balanced (twisted pair) cable. If 75  $\Omega$  unbalanced (coaxial) cable is to be connected, the module must contain a balun card that converts 75  $\Omega$  unbalanced to 100/120  $\Omega$  balanced line.

LAPD concentration and LAPD multiplexing are used to make the transmission resource more efficient.

### Optional Transmission Equipment

The cabinet can be connected to optional transmission equipment that is mounted externally. The optional transmission equipment used is:

- Transmission adapter (not connected to DF)
- DXX (installed in the OXU)
- Mini-link
- Mini DXC (installed in the OXU)
- TMR 9202

The connectors used for this are:

- PCM cables
- +24 V DC cables
- Blank panels for connectors to the OXU

## 9

### Alarms

The RBS 2206 can be connected to a maximum of 16 external alarms. A DF is used for external alarm connection. Each alarm connection is provided with over-voltage protection. (One OVP module protects two alarm connections.)

The alarm device can set the alarm by either an open or closed circuit. The alarm device connected to the screw terminals should be isolated relay contacts. A closed contact (logic zero) is required to be below 2 k $\Omega$ , and an open contact (logic one) above 100 k $\Omega$ . The current through a closed 0  $\Omega$  contact is 1.2 mA. The voltage between terminals with an open contact is 24 V



DC. The external alarms are defined during installation using the Operation and Maintenance Terminal (OMT) or from the BSC.

## 10 Standards, Regulations and Dependability

In this section a brief overview of standards, type approval, and electromagnetic compatibility are stated.

### 10.1 Safety Standards

In accordance with the market requirements, the RBS 2206 complies with the following product safety standards:

- 73/23/EEC Low voltage directive
- IP 20 according to IEC/EN 60529
- FCC rules, part 68
- EN 60950 / IEC 60950
- EN 60215 / IEC 60215
- UL 1950 / CSA C22.2 No.950

### 10.2 Other Standards and Regulations

#### Marking

The product is marked with signs to show compliance with product safety standards.

#### Type Approval Standards

The RBS complies with the European Community and the North America market requirements regarding radio performance. The product has the CE and FCC signs to show compliance to the legal requirements in respective region.

#### Electromagnetic Compatibility (EMC)

The RBS complies with the European Community and the North America market requirements regarding EMC. The product has the CE and FCC signs to show compliance to the legal requirements in each respective region.

## Dependability

The RBS 2206 is designed for a technical lifetime of 25 years (24-hour operation). The following preventive maintenance conditions must be fulfilled to guarantee the availability of the RBS:

Fans	The fans must be inspected (cleaned if necessary) every year. The lifetime is estimated to at least 5 years.
Air filters	The air filters must be regularly inspected and cleaned (interval depends on the environmental conditions at the site).

## Vandal Resistance

Unauthorised access is not possible without damaging the unit.

# RBS 2106 and RBS 2206 Radio Configurations

## Description

This document describes the radio configurations for RBS 2106 and RBS 2206.

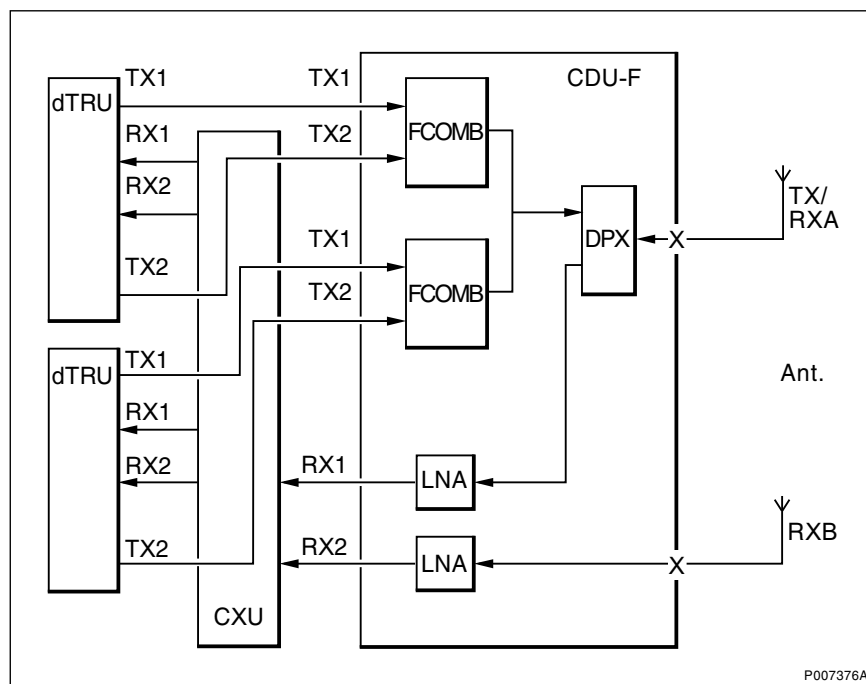

## Contents

<b>1</b>	<b>Introduction</b>	<b>3</b>
1.1	Mobile Telephone System	3
1.2	Radio Base Station	4
<b>2</b>	<b>References</b>	<b>4</b>
<b>3</b>	<b>Definitions</b>	<b>5</b>
3.1	Cabinet Types	6
3.2	Configurations Identity	7
<b>4</b>	<b>Frequency Bands</b>	<b>8</b>
<b>5</b>	<b>Basic Configurations</b>	<b>9</b>
5.1	dTRU Topology	10
5.2	CDU-F Configurations	11
5.3	CDU-G Configurations	25
5.4	RX Connection from Antenna to dTRU	52
<b>6</b>	<b>Site Cell Configurations (SCC)</b>	<b>57</b>
6.1	RBS 2106 and RBS 2206 Configurations	58
6.2	RBS 2106 and RBS 2206 Dual Band Configurations	68
6.3	SW Power Boost Configurations with CDU-G	76
6.4	Transmitter Coherent Combining (TCC) Configurations with CDU-G	77
<b>7</b>	<b>Co-Siting with RBS 200 or RBS 2000 Macro Cabinets</b>	<b>78</b>
7.1	RBS 200 Expanded with 12-TRX Cabinet	78
7.2	6-TRX RBS 2000 Macro Cabinets Expanded with 12-TRX Cabinet	81
7.3	12-TRX RBS 2000 Macro Cabinet Expanded with 12-TRX Cabinet	83
<b>8</b>	<b>Co-Siting with TDMA RBS Using an ASU</b>	<b>85</b>
8.1	Separate TX and Two Separate RX Antennas	85
8.2	One Duplex Antenna RX/TX	86
8.3	Two Separate Duplex Antennas	86
8.4	One RX and One Duplex Antenna	87

# 1 Introduction

The radio configurations described are valid for RBS 2106 and RBS 2206, equipped with a maximum of six dTRUs/12 TRXs per cabinet. The descriptions include basic configurations, site cell configurations, and co-siting. They also include information about configurations with CDU-G and CDU-F as well as valid GSM frequencies (the GSM 800 configurations are valid from BSS R9).

## 1.1 Mobile Telephone System

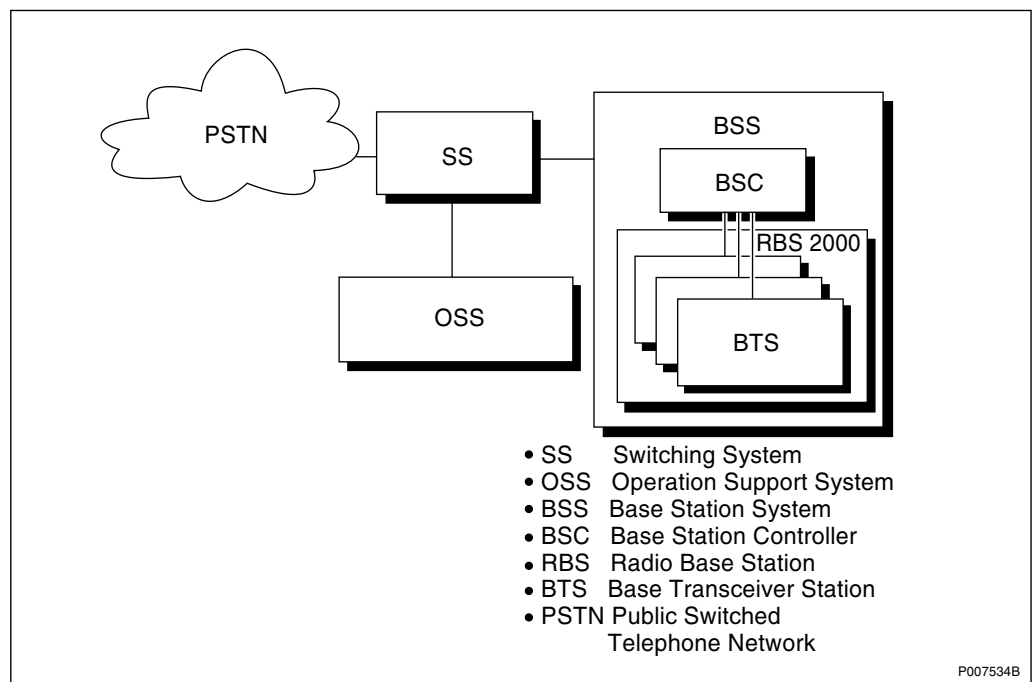

*Figure 1 RBS 2000 in the Ericsson GSM system*

The Base Station System (BSS) contains two functional entities; the Base Station Controller (BSC) and the Base Transceiver Station (BTS).

The BSC handles radio-related functions, such as handover, management of the radio network resources, and cell configuration data. It also controls radio frequency power levels in RBSs and MSs.

The BTS is a network component which serves one cell and is controlled by the BSC. The BTS contains a number of transceivers. It consists of the radio transceivers and all the digital signal processing equipment. RBS 2000 contains equipment for 1 – 3 BTSs.

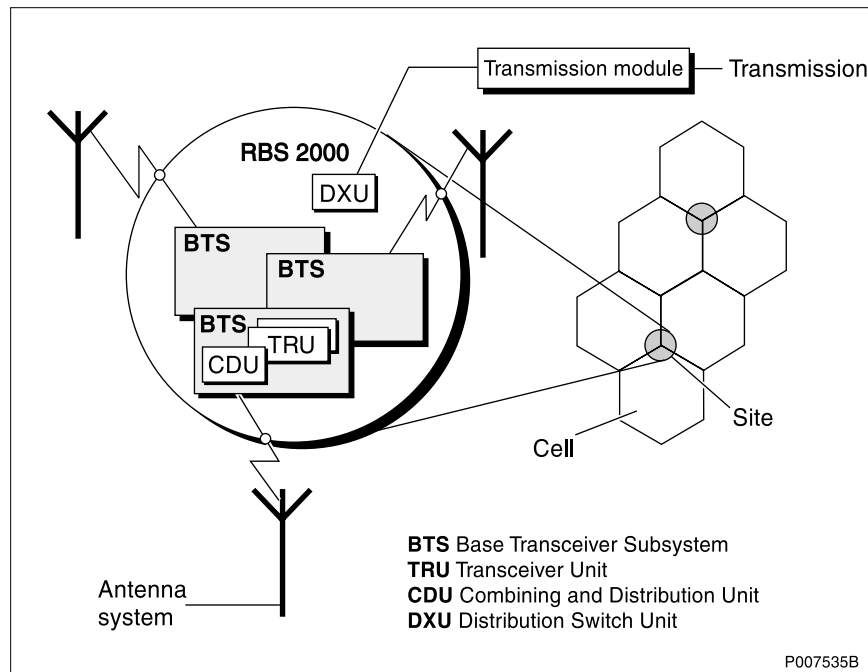

Figure 2 An example of an RBS 2000 servicing a three-cell site

## 1.2 Radio Base Station

The Radio Base Station 2000 (RBS 2000) is Ericsson's second generation of RBSs developed to meet the GSM specifications for BTSs.

## 2 References

- GSM:05.05** GSM Requirements 05.05 phase 2+ Radio Transmission and Reception.
- GSM:05.08** GSM Requirements 05.08 phase 2+ Radio Subsystem Link Control.

### 3 Definitions

#### Tower Mounted Amplifier (TMA)

The TMA compensates for signal loss in the receiver antenna cables, reduces system noise and improves uplink sensitivity. The TMA can consist of a duplex filter. Duplex is the function that allows communication in two directions (sending and receiving) on one channel.

The TMA used for 12 TRX products is Dual Duplex TMA (ddTMA).

Some configurations can use a TMA designed for reception only (rTMA).

#### Antenna Reference Point

The antenna reference point is the point where the radio signal crosses the RBS border, that is, the connector for the antenna feeder. See the figure below.

**Note:** The TMA is inside the RBS border.

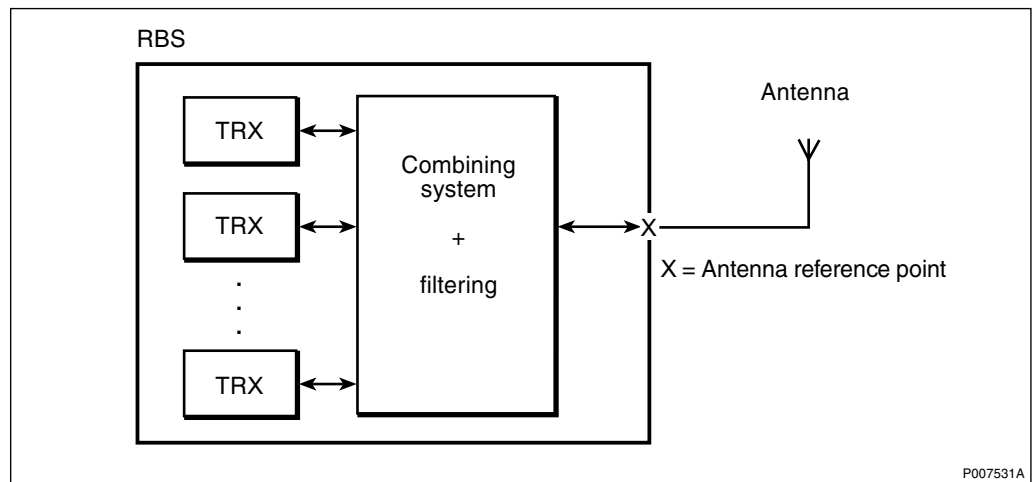

Figure 3 Antenna reference point

#### Antenna System

The antenna system is constituted by all RF transmission and reception antennas, directed to cover the same area or multi-casting configurations.

#### Antenna Sharing Unit (ASU)

An ASU is used for sharing RX antennas between RBSs.

### Base Transceiver Station (BTS)

A BTS is a unit operating on a set of frequencies in one cell.

### Basic Configuration

A basic configuration is a specified set of transceivers, CDUs, and in some cases, TMAs, connected to one antenna system.

A basic configuration can be multiplied or used in combination with other basic configurations to build the needed site equipment.

Variations of a basic configuration may exist, differing in cable lengths. This depends on factors such as implementation in different cabinets.

### Radio Base Station (RBS)

An RBS is all equipment in an Ericsson base station, and may be comprised of several BTSs.

Each RBS has one DXU, controlling a maximum of 12 TRXs.

### Site Cell Configuration (SCC)

The SCC is a geographical concept describing how an area around one RBS site is divided into radio traffic areas. The following types of site are defined:

<b>Omni-site</b>	Radio coverage in one 360 degree sector, that is in one area, using one BTS.
<b>2-sector site</b>	Radio coverage in two sectors, that is two distinct areas, using two BTSs.
<b>3-sector site</b>	Radio coverage in three sectors, that is three distinct areas, using three BTSs.

## 3.1

### Cabinet Types

<b>RBS 2106</b>	Outdoor cabinet with a maximum of six dTRUs/12 TRXs per cabinet
<b>RBS 2206</b>	Indoor cabinet with a maximum of six dTRUs/12 TRXs per cabinet



### 3.2 Configurations Identity

The figure below shows how a basic configuration identity is constructed.

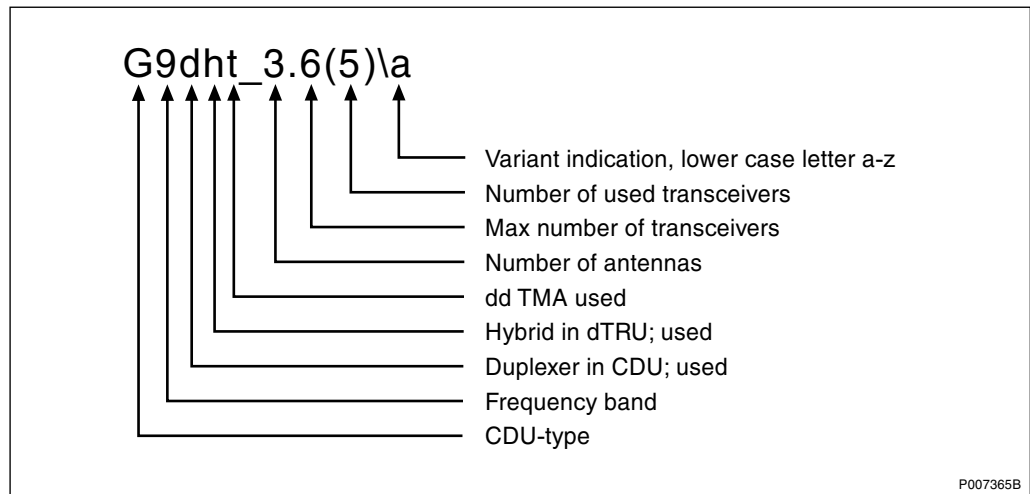

Figure 4 Basic configuration identity

## 4 Frequency Bands

GSM 800	Uplink:	824 – 849 MHz
	Downlink:	869 – 894 MHz
P-GSM 900	Uplink:	890 – 915 MHz
	Downlink:	935 – 960 MHz
E-GSM 900	Uplink:	880 – 915 MHz
	Downlink:	925 – 960 MHz
GSM 1800	Uplink:	1710 – 1785 MHz
	Downlink:	1805 – 1880 MHz
GSM 1900	Uplink:	1850 – 1910 MHz
	Downlink:	1930 – 1990 MHz

These frequency bands are supported by the configurations described in this document.

## 5 Basic Configurations

The GSM 800, GSM 900, GSM 1800 and GSM 1900 configurations meet the GSM requirements, except where otherwise stated.

The capacity of a configuration is defined at the TX and RX antenna reference points at the RBS border. There is an X close to every reference point in the following figures. The RBS border is not included in the figures.

The equivalent output power with SW power boost (TX diversity) configured is the original output power specified for the basic configuration increased with typically 3 dB, if separate TX antennas are used. The configurations that support SW power boost are listed in Section 6.3 on page 76.

Functional views of radio signal paths for various configurations are shown in Figure 5 on page 10 up to and including Figure 29 on page 51. Only components necessary to illustrate the configuration are shown.

In some configurations, the radio signal paths can differ depending on where in the cabinet the basic configuration is used. The figures show fully-equipped cabinets with two or three BTSs, that is two or three basic configurations are shown in the same figure. These are different physical implementations of the same basic configuration, not different configurations. The second BTS is drawn with dotted lines to show how an SCC in a fully-equipped cabinet is connected.

### 5.1 dTRU Topology

#### Configuration of Hybrid Combiner

The dTRU can be configured with or without the hybrid combiner, using two external cables.

#### RX Signals Distributed from Two Ports

The RX signals can be distributed from the RX1 and RX2 ports to all four receivers when both transceivers are connected to the same antenna system.

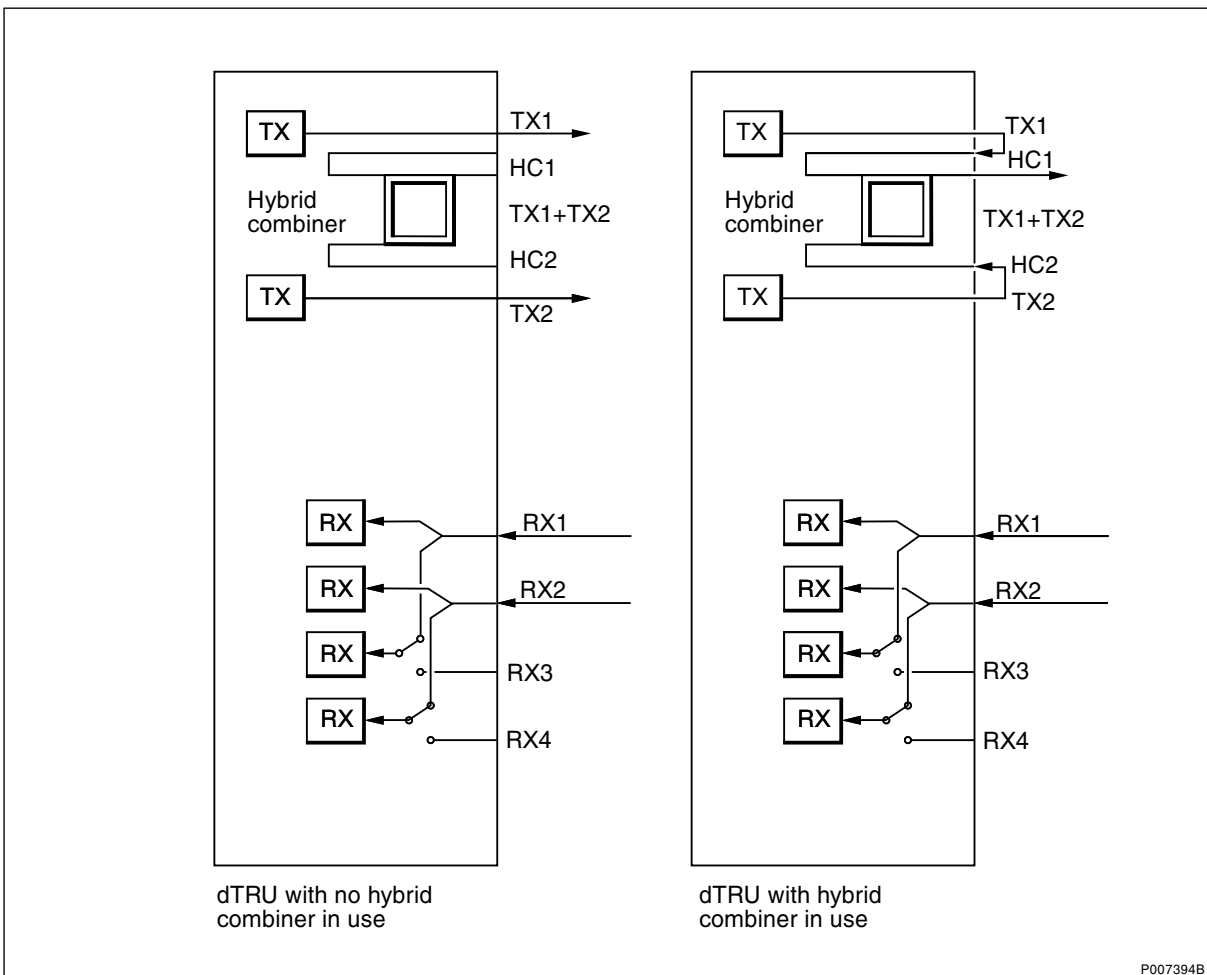

Figure 5 dTRU with and without hybrid combiner in use

## 5.2 CDU-F Configurations

### Basic Configuration F9d\_2.4 and F18d\_2.4

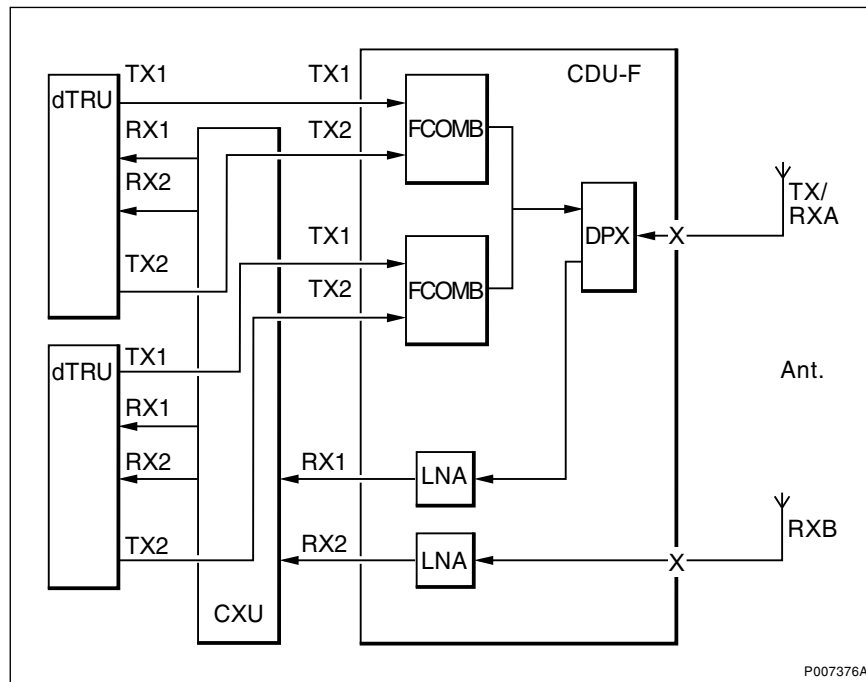

Figure 6 F9d\_2.4 and F18d\_2.4

#### Characteristics

Number of CDUs	1	
Frequency band	E-GSM	(F9d_2.4)
	GSM 1800	(F18d_2.4)
Max. number of TRXs	4	
Number of feeders	2	
Number of antennas	2	
Antenna configuration	TX/RX + RX	

**Basic Configuration F9dt\_2.4 and F18dt\_2.4**

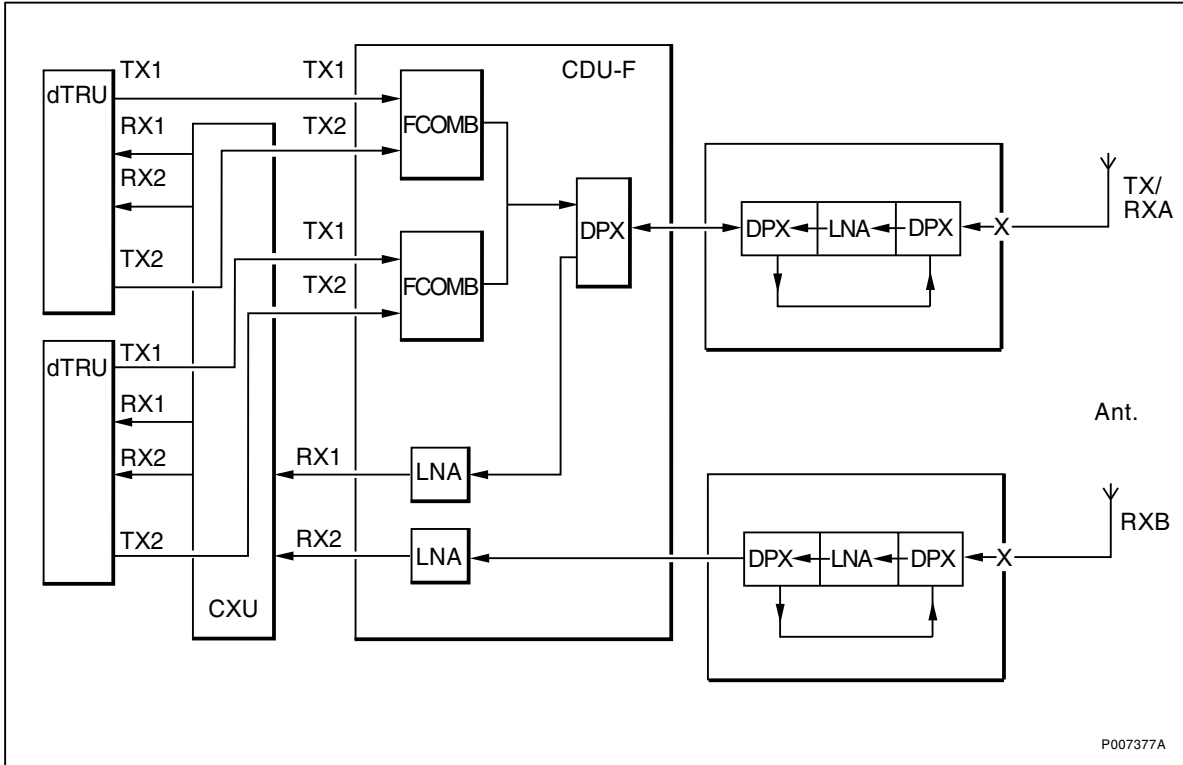

Figure 7 F9dt\_2.4 and F18dt\_2.4

**Characteristics**

Number of CDUs	1	
Frequency band	E-GSM	(F9dt_2.4)
	GSM 1800	(F18dt_2.4)
Max. number of TRXs	4	
Number of feeders	2	
Number of antennas	2	
Antenna configuration	TX/RX + RX	
TMA configuration	ddTMA + ddTMA or ddTMA + rTMA	

**Basic Configuration F9d\_2.6 and F18d\_2.6**

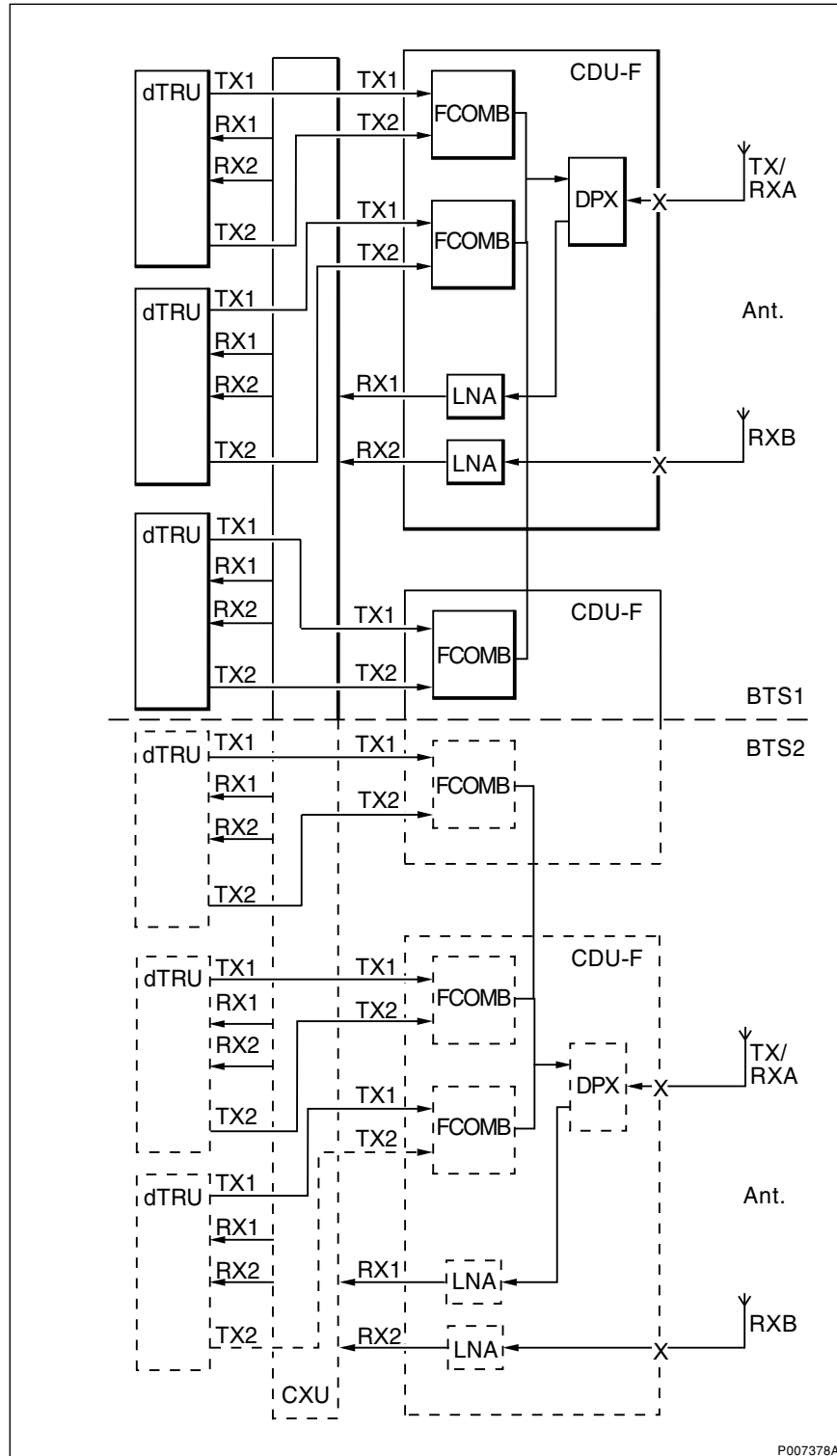

Figure 8 F9d\_2.6 and F18d\_2.6

**Characteristics**

Number of CDUs	2*	
Frequency band	E-GSM	(F9d_2.6)
	GSM 1800	(F18d_2.6)
Max. number of TRXs	6	
Number of feeders	2	
Number of antennas	2	
Antenna configuration	TX/RX + RX	

\* Three CDU-Fs support two sectors.

**Note:** The second BTS is only shown to illustrate a 2 x 6 configuration. BTS1 and BTS2 are two different physical implementations of the same basic configuration.



**Basic Configuration F9dt\_2.6 and F18dt\_2.6**

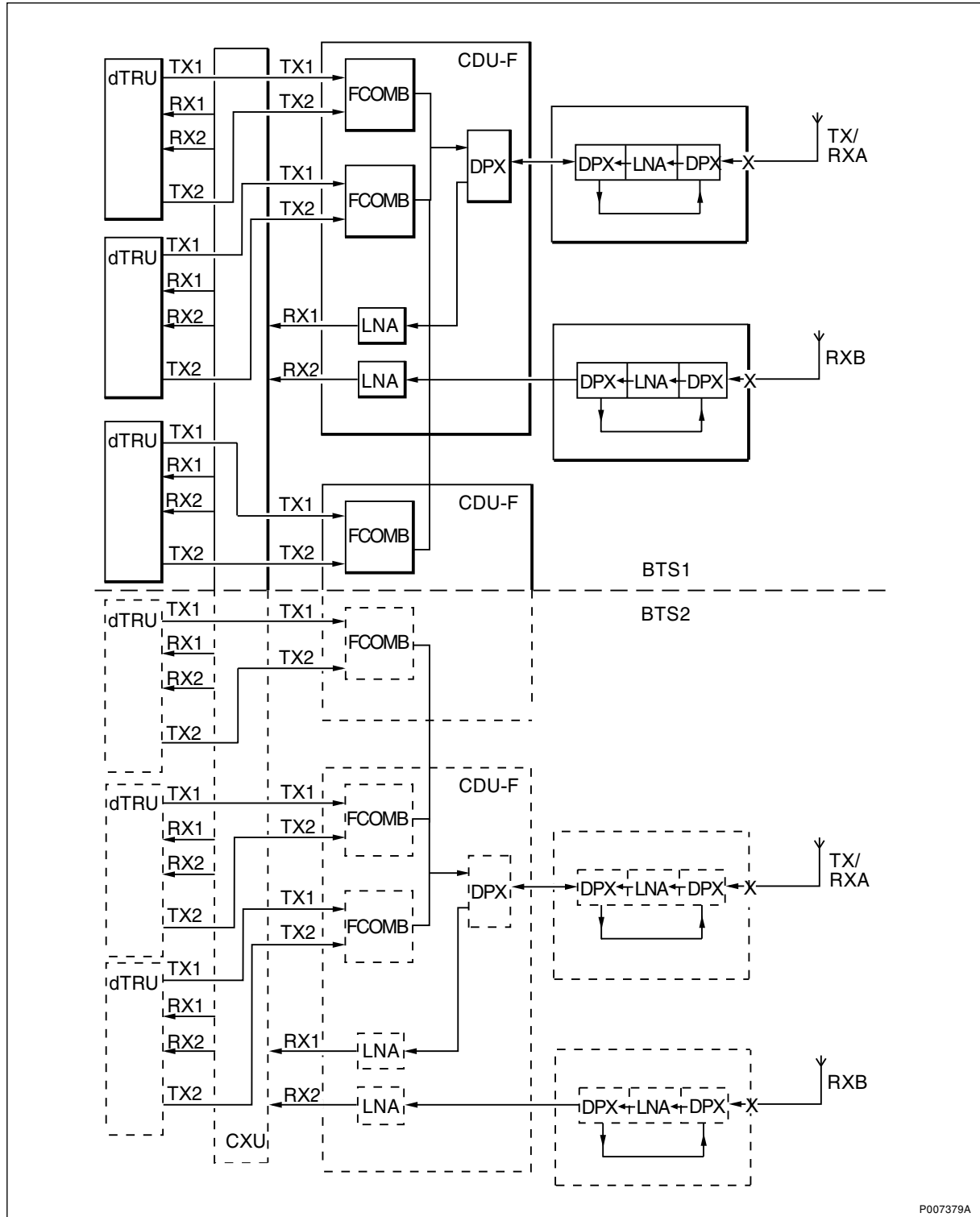

P007379A

Figure 9 F9dt\_2.6 and F18dt\_2.6

**Characteristics**

Number of CDUs	2*	
Frequency band	E-GSM	(F9dt_2.6)
	GSM 1800	(F18dt_2.6)
Max. number of TRXs	6	
Number of feeders	2	
Number of antennas	2	
Antenna configuration	TX/RX + RX	
TMA configuration	ddTMA + ddTMA or ddTMA + rTMA	

\* Three CDU-Fs support two sectors.

**Note:** The second BTS is only shown to illustrate a 2 x 6 configuration. BTS1 and BTS2 are two different physical implementations of the same basic configuration.

**Basic Configuration F9d\_2.8 and F18d\_2.8**

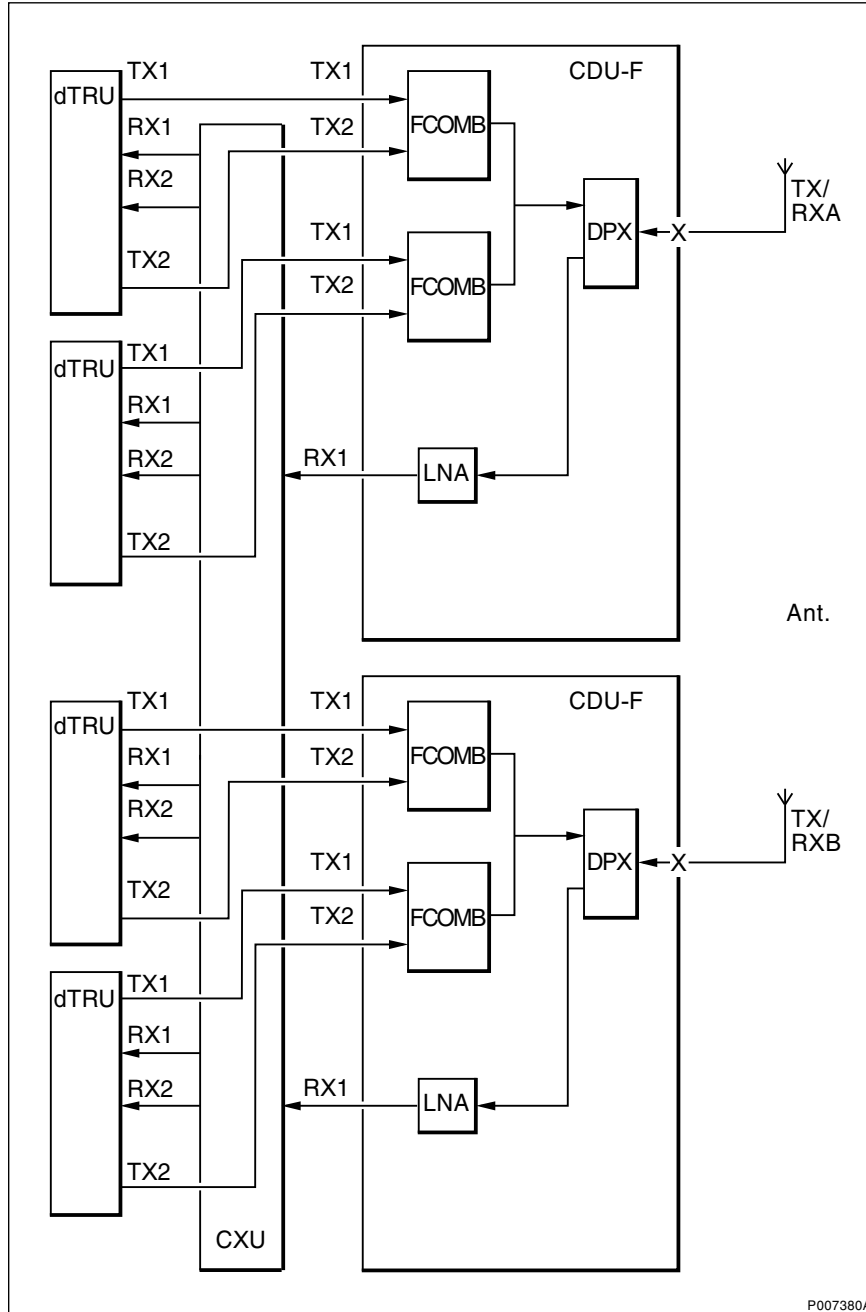

Figure 10 F9d\_2.8 and F18d\_2.8

**Characteristics**

Number of CDUs	2	
Frequency band	E-GSM	(F9d_2.8)
	GSM 1800	(F18d_2.8)
Max. number of TRXs	8	
Number of feeders	2	
Number of antennas	2	
Antenna configuration	TX/RX + TX/RX	

**Basic Configuration F9dt\_2.8 and F18dt\_2.8**

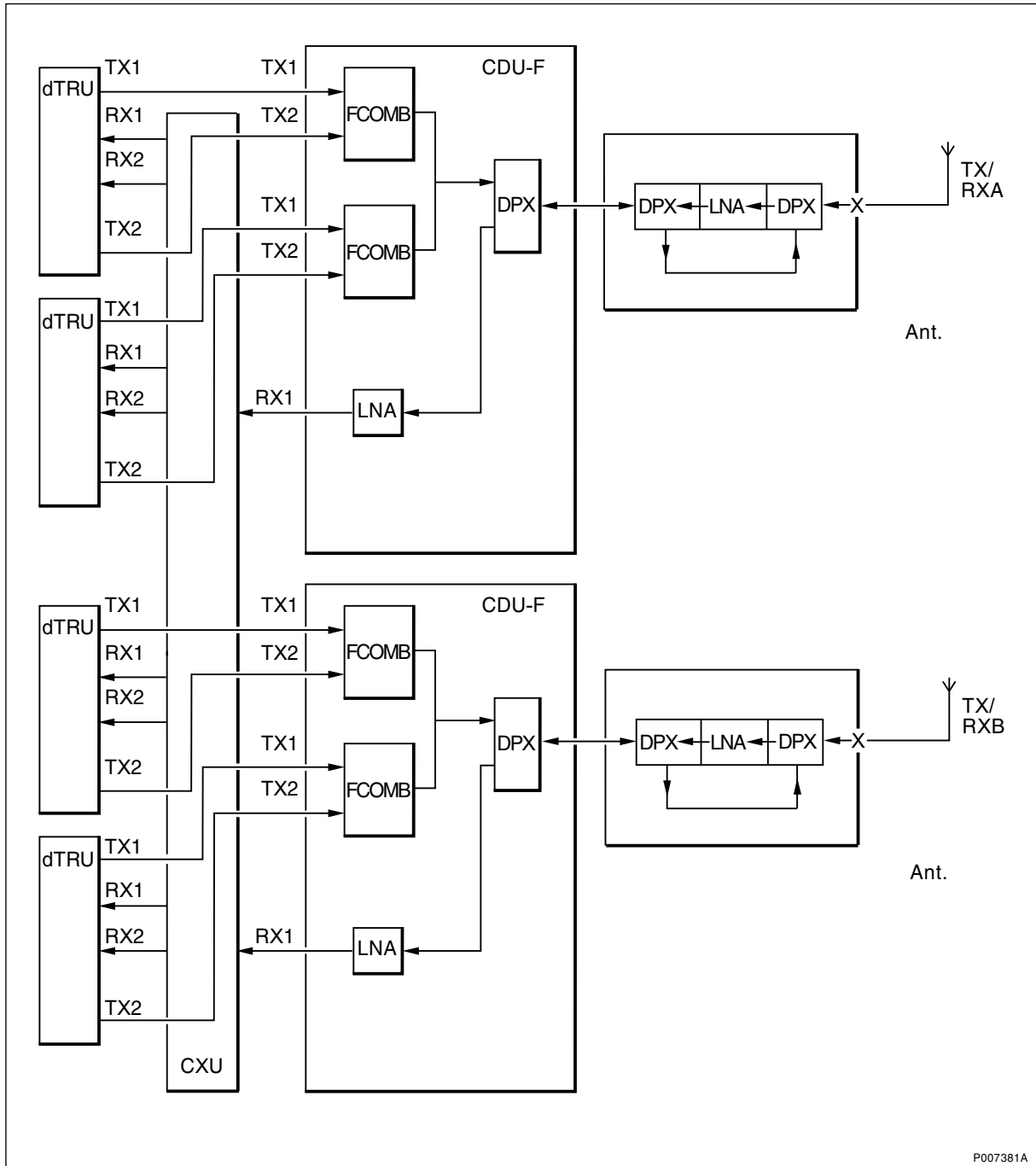

Figure 11 F9dt\_2.8 and F18dt\_2.8

**Characteristics**

Number of CDUs	2	
Frequency band	E-GSM	(F9dt_2.8)
	GSM 1800	(F18dt_2.8)
Max. number of TRXs	8	
Number of feeders	2	
Number of antennas	2	
Antenna configuration	TX/RX + TX/RX	
TMA configuration	ddTMA + ddTMA	

**Basic Configuration F9d\_2.12 and F18d\_2.12**

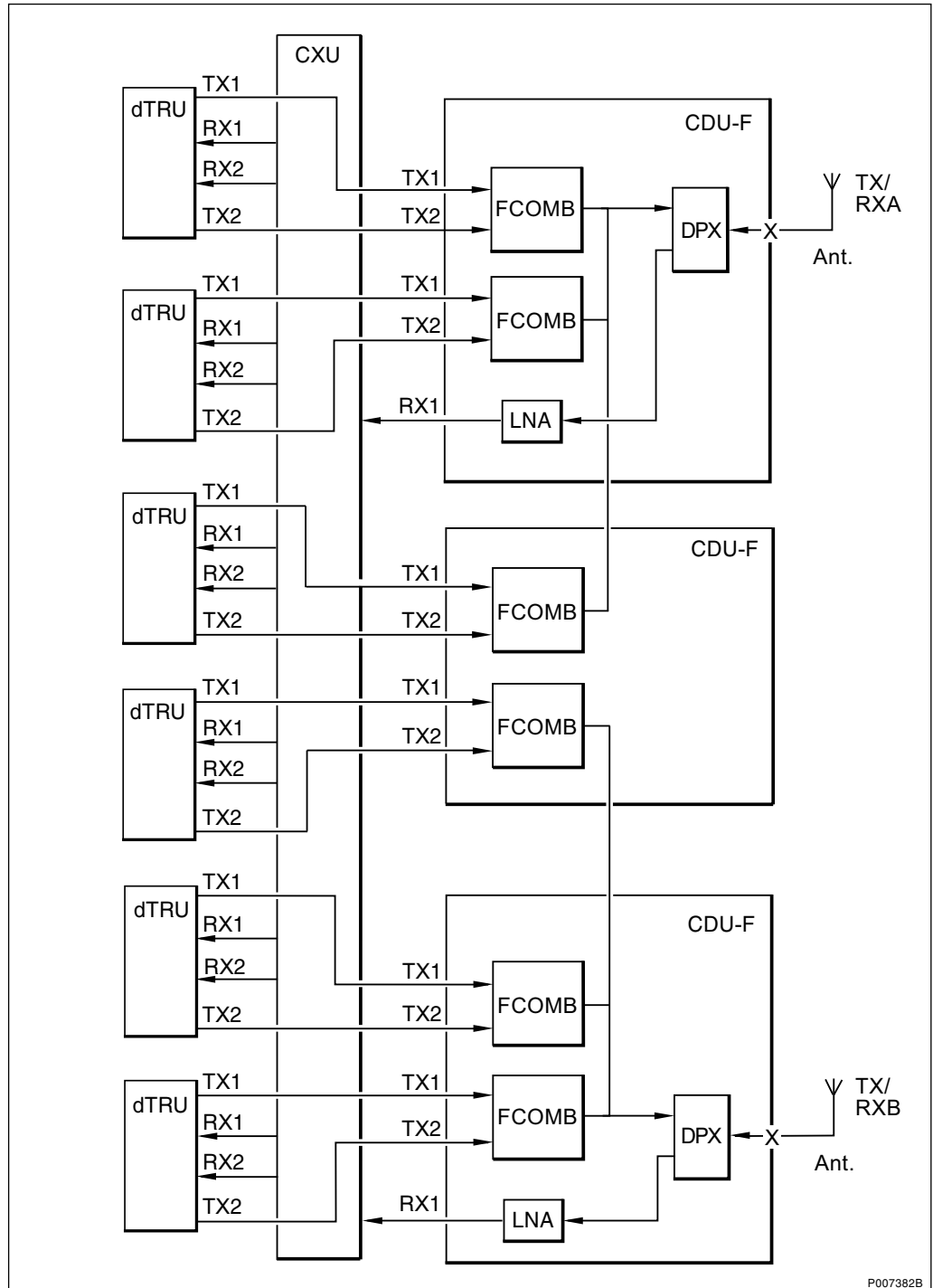

Figure 12 F9d\_2.12 and F18d\_2.12

**Characteristics**

Number of CDUs	3	
Frequency band	E-GSM	(F9d_2.12)
	GSM 1800	(F18d_2.12)
Max. number of TRXs	12	
Number of feeders	2	
Number of antennas	2	
Antenna configuration	TX/RX + TX/RX	



**Basic Configuration F9dt\_2.12 and F18dt\_2.12**

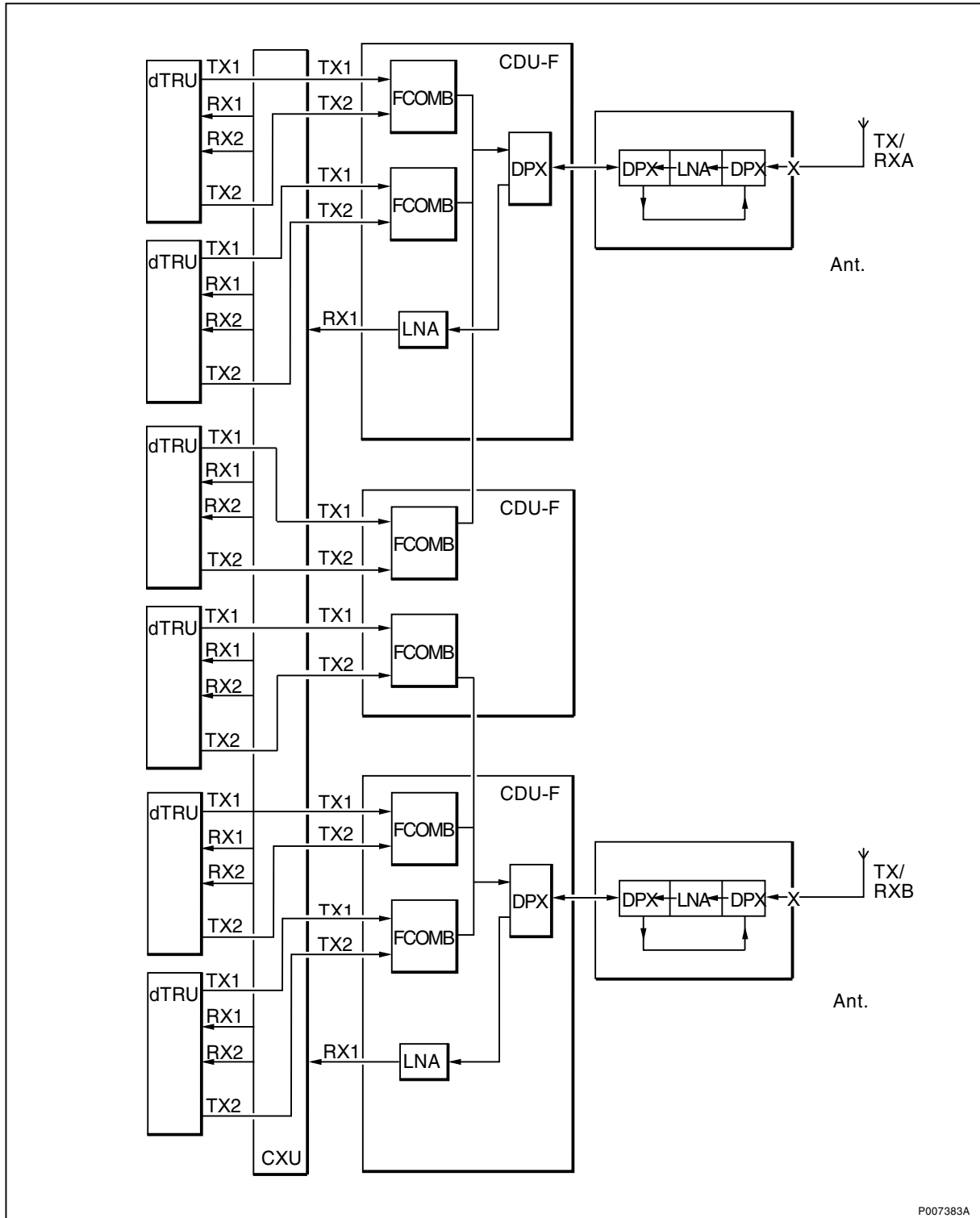

P007383A

Figure 13 F9d\_2.12 and F18dt\_2.12

**Characteristics**

Number of CDUs	3	
Frequency band	E-GSM	(F9dt_2.12)
	GSM 1800	(F18dt_2.12)
Max. number of TRXs	12	
Number of feeders	2	
Number of antennas	2	
Antenna configuration	TX/RX + TX/RX	
TMA configuration	ddTMA + ddTMA	

### 5.3 CDU-G Configurations

#### Basic Configuration G8d\_2.1, G9d\_2.1, G18d\_2.1 and G19d\_2.1

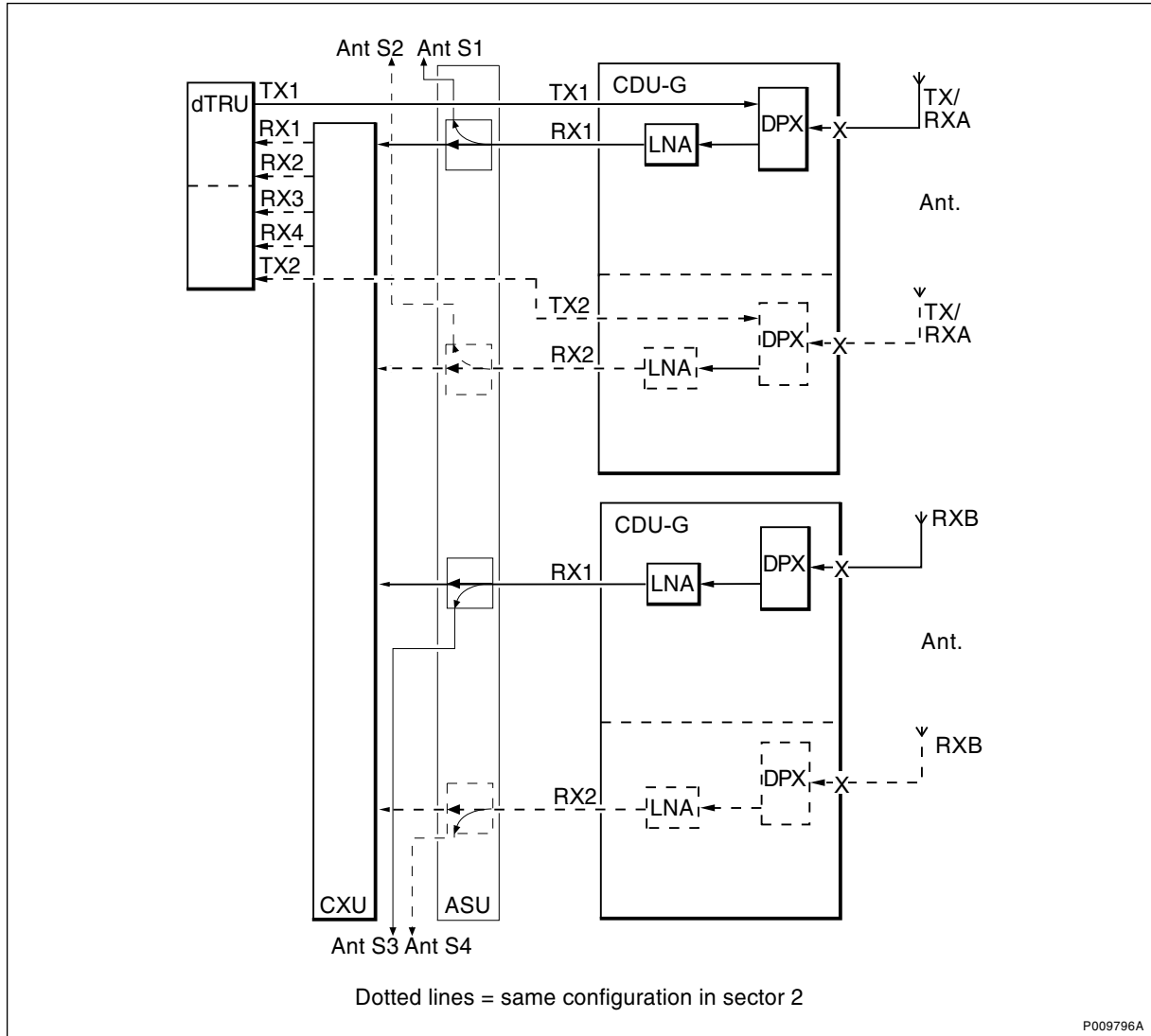

Figure 14 G8d\_2.1, G9d\_2.1, G18d\_2.1 and G19d\_2.1

**Characteristics**

Number of CDUs	2 (2 CDUs support two sectors)
Frequency band	GSM 800 (G8d_2.1)
	E-GSM (G9d_2.1)
	GSM 1800 (G18d_2.1)
	GSM 1900 (G19d_2.1)
Max. number of TRXs	1 (1 dTRU supports two sectors)
Number of feeders	2
Number of antennas	2
Antenna configuration	TX/RX + RX

**Note:** The ASU is optional equipment.

**Basic Configuration G8dt\_2.1, G9dt\_2.1, G18dt\_2.1 and G19dt\_2.1**

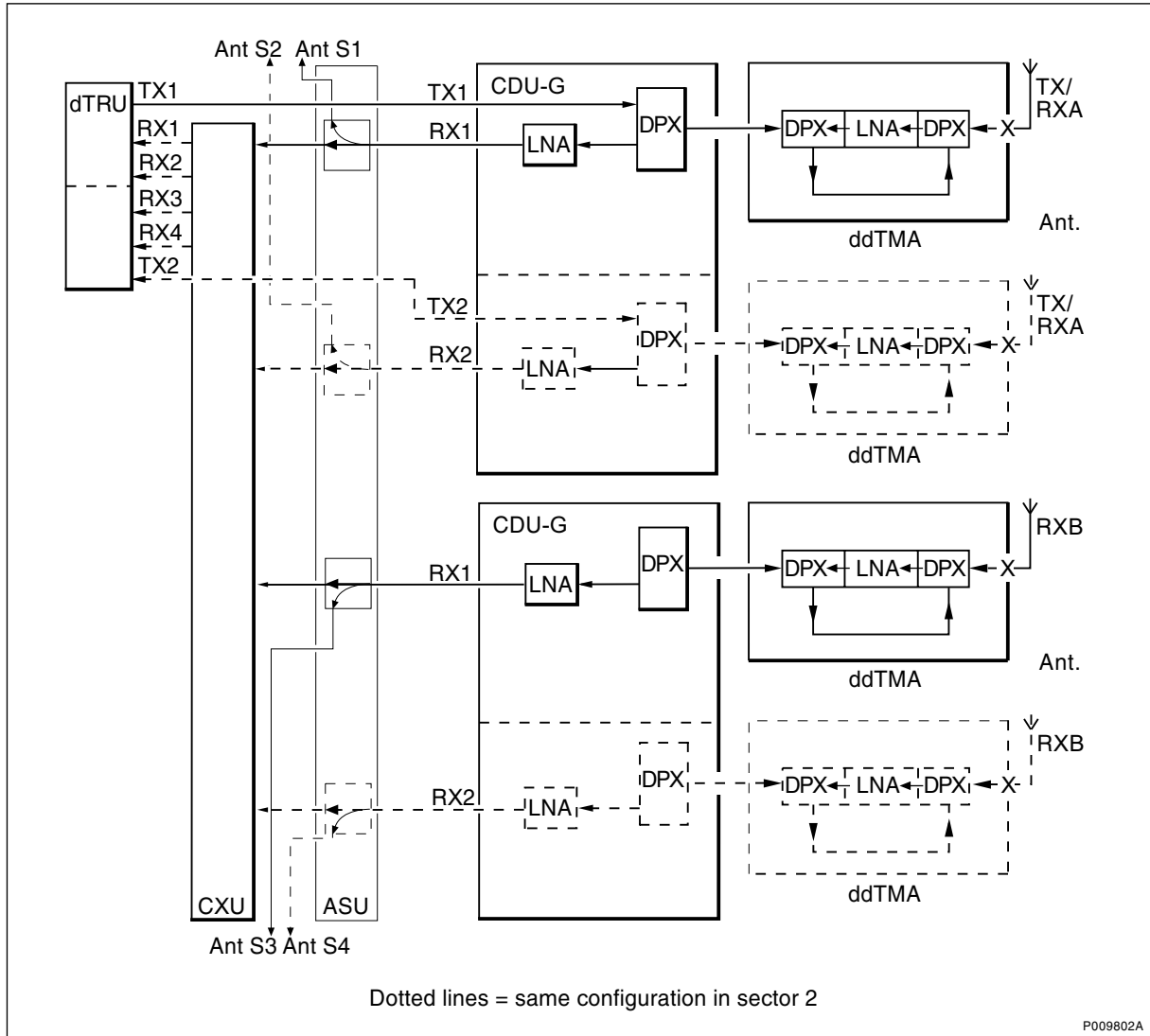

Figure 15 G8dt\_2.1, G9dt\_2.1, G18dt\_2.1 and G19dt\_2.1

**Characteristics**

Number of CDUs	2 (2 CDUs support two sectors)
Frequency band	GSM 800 (G8dt_2.1)
	E-GSM (G9dt_212)
	GSM 1800 (G18dt_2.1)
	GSM 1900 (G19dt_2.1)
Max. number of TRXs	1 (1 dTRU supports two sectors)
Number of feeders	2
Number of antennas	2
Antenna configuration	TX/RX + RX
TMA configuration	ddTMA + ddTMA

**Note:** The ASU is optional equipment.

### Basic Configuration G8d\_2.2, G9d\_2.2, G18d\_2.2 and G19d\_2.2

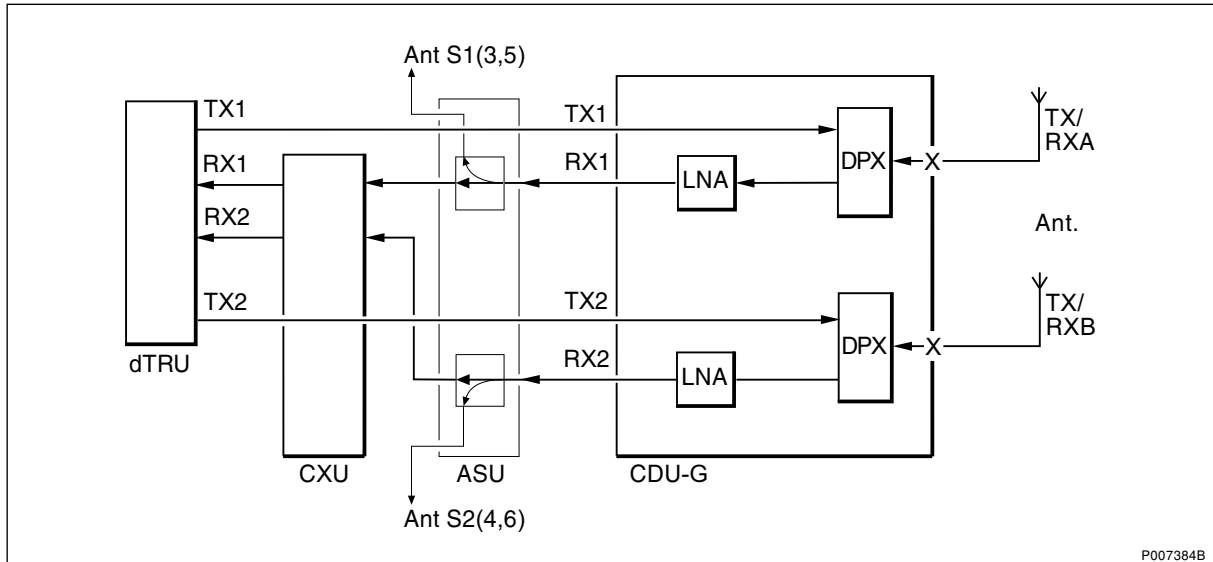

Figure 16 Gd8\_2.2, G9d\_2.2, G18d\_2.2 and G19d\_2.2

#### Characteristics

Number of CDUs	1	
Frequency band	GSM 800	(G8d_2.2)
	E-GSM	(G9d_2.2)
	GSM 1800	(G18d_2.2)
	GSM 1900	(G19d_2.2)
Max. number of TRXs	2	
Number of feeders	2	
Number of antennas	2	
Antenna configuration	TX/RX + TX/RX	

**Note:** The ASU is optional equipment.

**Basic Configuration G8dt\_2.2, G9dt\_2.2, G18dt\_2.2 and G19dt\_2.2**

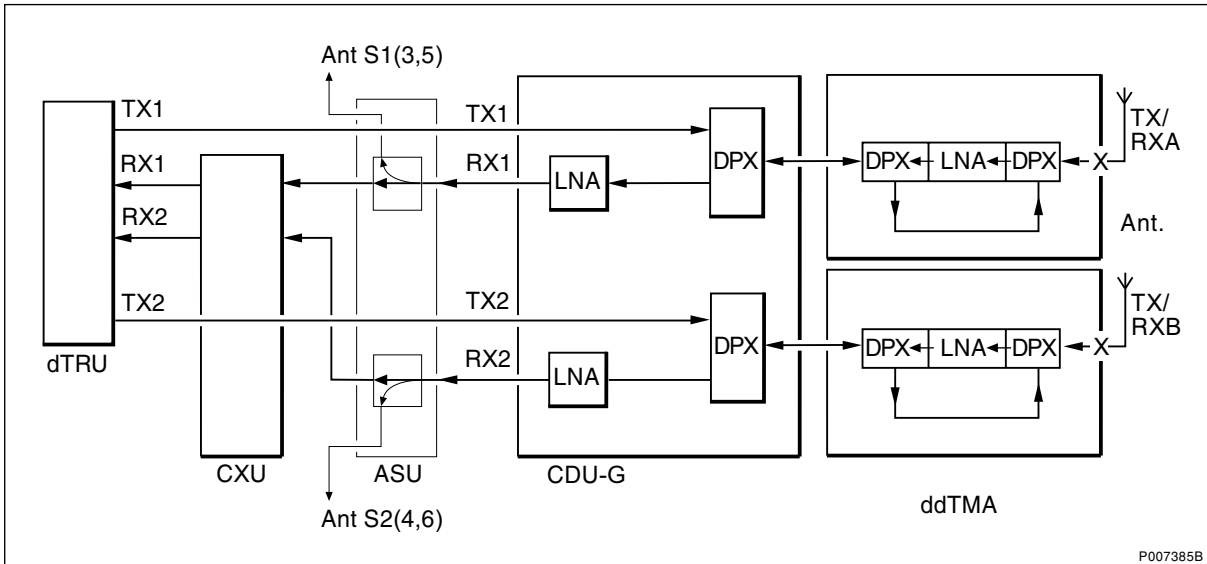

Figure 17 G8dt\_2.2, G9dt\_2.2, G18dt\_2.2 and G19dt\_2.2

**Characteristics**

Number of CDUs	1	
Frequency band	GSM 800	(G8dt_2.2)
	E-GSM	(G9dt_2.2)
	GSM 1800	(G18dt_2.2)
	GSM 1900	(G19dt_2.2)
Max. number of TRXs	2	
Number of feeders	2	
Number of antennas	2	
Antenna configuration	TX/RX + TX/RX	
TMA configuration	ddTMA + ddTMA	

**Note:** The ASU is optional equipment.



**Basic Configuration G8d\_4.4, G9d\_4.4, G18d\_4.4 and G19d\_4.4**

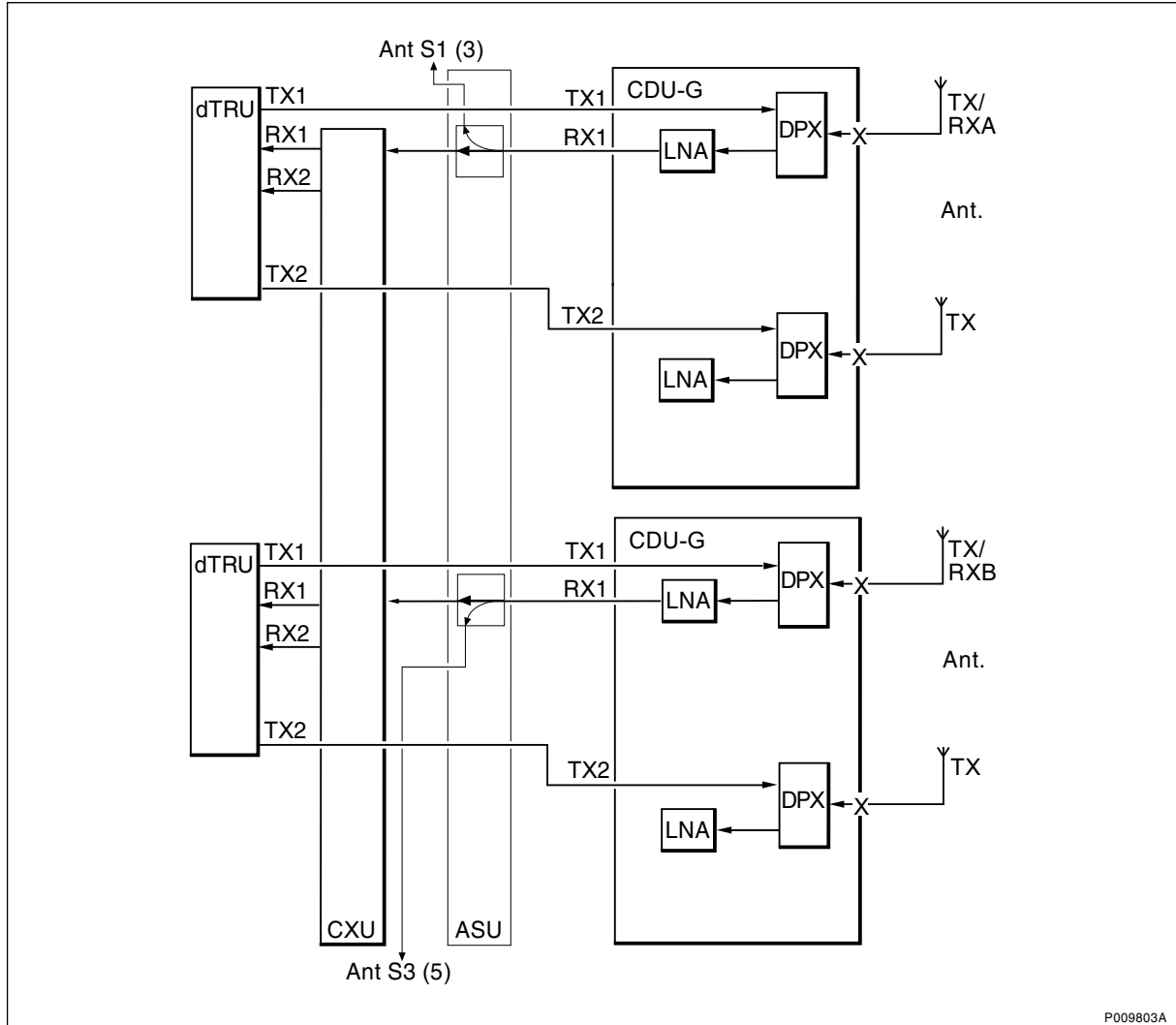

P009803A

Figure 18 G8d\_4.4, G9d\_4.4, G18d\_4.4, G19d\_4.4

**Characteristics**

Number of CDUs	2	
Frequency band	GSM 800	(G8d_4.4)
	E-GSM	(G9d_4.4)
	GSM 1800	(G18d_4.4)
	GSM 1900	(G19d_4.4)
Max. number of TRXs	4	
Number of feeders	4	
Number of antennas	4	
Antenna configuration	TX/RX + TX + TX/RX + TX	

**Note:** The ASU is optional equipment.

**Basic Configuration G8dt\_4.4, G9dt\_4.4, G18dt\_4.4, and G19dt\_4.4**

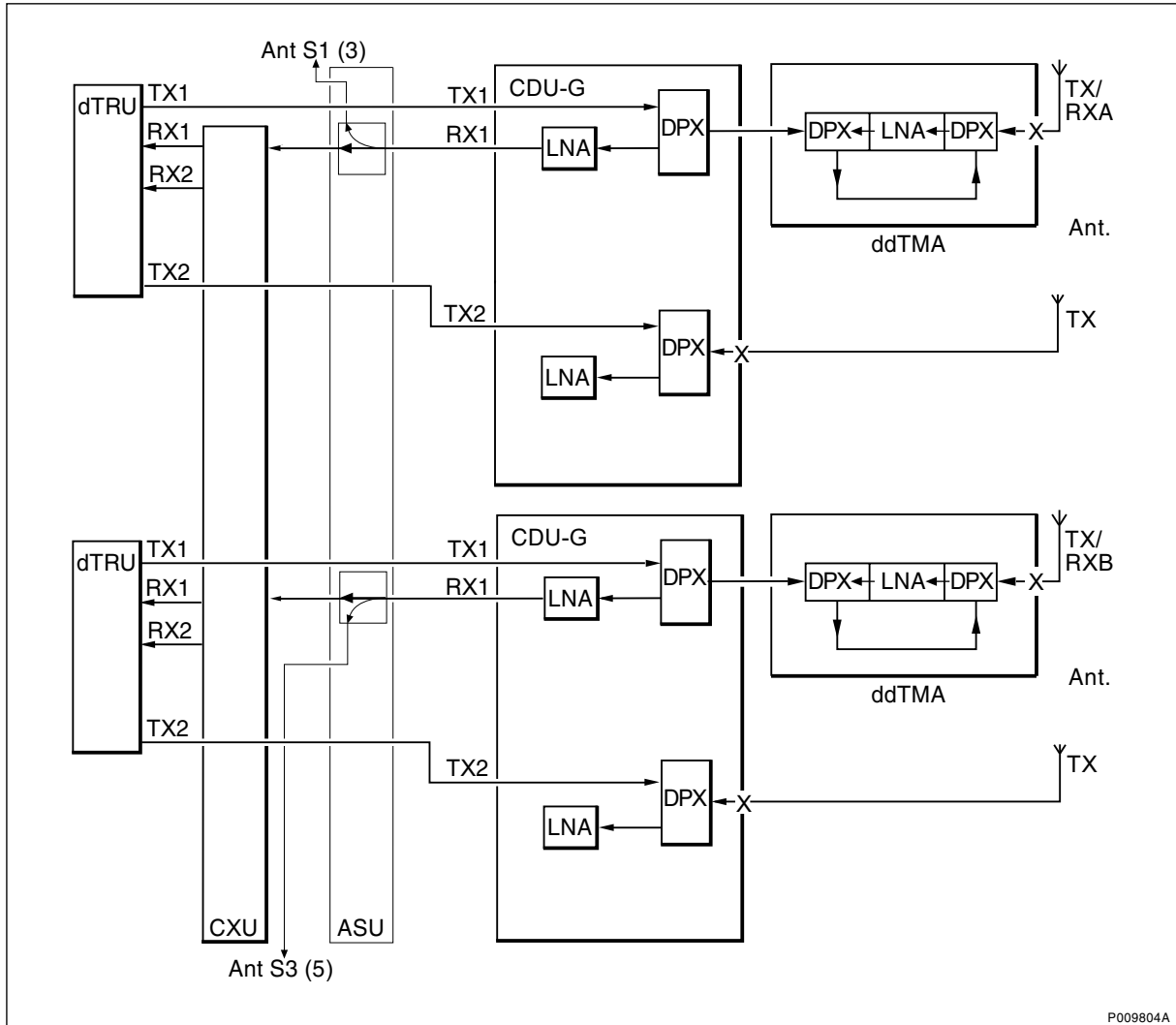

Figure 19 G8dt\_4.4, G9dt\_4.4, G18dt\_4.4 and G19dt\_4.4

**Characteristics**

Number of CDUs	2	
Frequency band	GSM 800	(G8dt_4.4)
	E-GSM	(G9dt_4.4)
	GSM 1800	(G18dt_4.4)
	GSM 1900	(G19dt_4.4)
Max. number of TRXs	4	
Number of feeders	4	
Number of antennas	4	
Antenna configuration	TX/RX + TX + TX/RX + TX	
TMA configuration	ddTMA + ddTMA	

**Note:** The ASU is optional equipment.

**Basic Configuration G8d\_6.6, G9d\_6.6, G18d\_6.6 and G19d\_6.6**

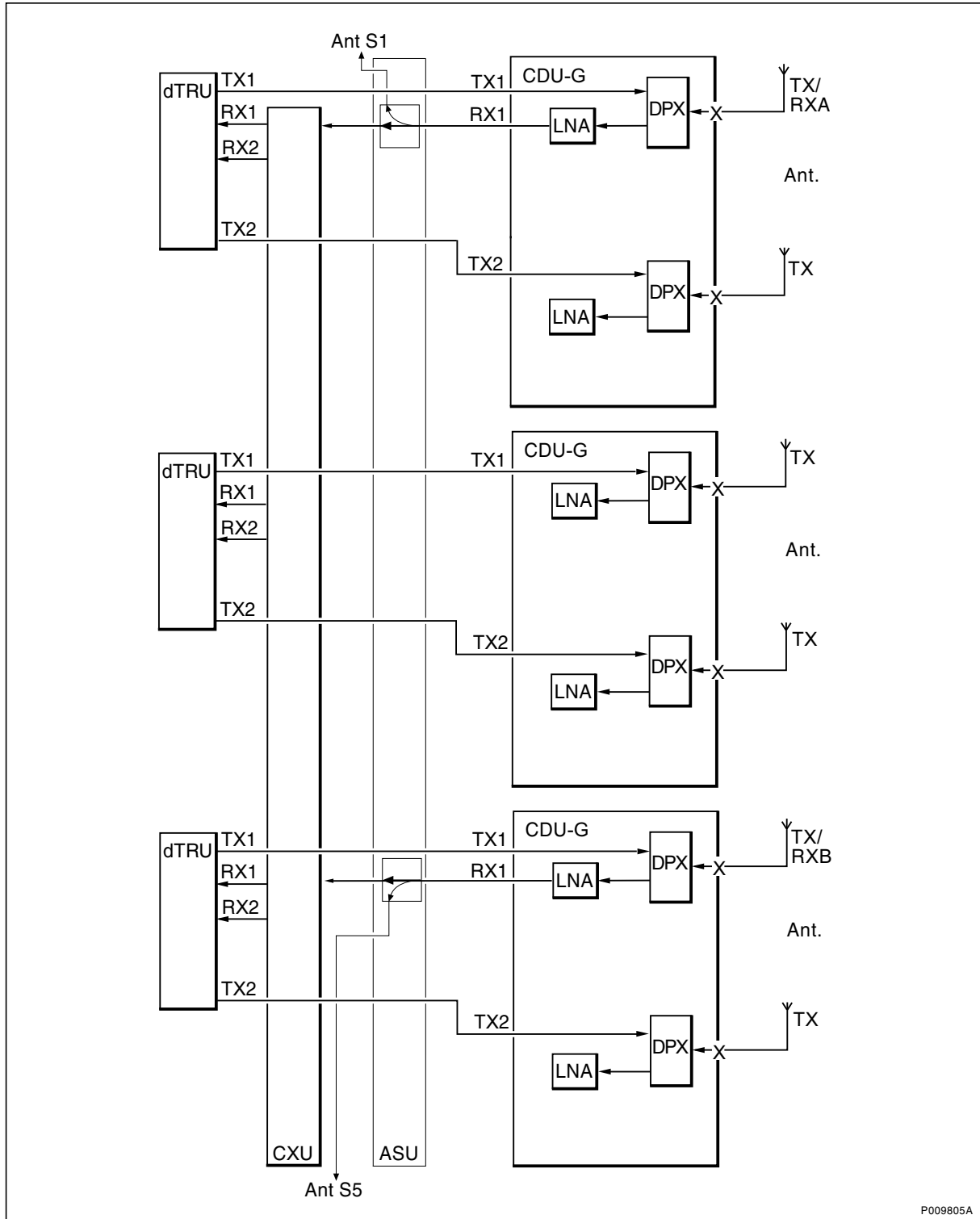

Figure 20 G8d\_6.6, G9d\_6.6, G18d\_6.6 and G19d\_6.6

**Characteristics**

Number of CDUs	3	
Frequency band	GSM 800	(G8d_6.6)
	E-GSM	(G9d_6.6)
	GSM 1800	(G18d_6.6)
	GSM 1900	(G19d_6.6)
Max. number of TRXs	6	
Number of feeders	6	
Number of antennas	6	
Antenna configuration	TX/RX + TX + TX + TX + TX/RX + TX	

**Note:** The ASU is optional equipment.

**Basic Configuration G8dt\_6.6, G9dt\_6.6, G18dt\_6.6 and G19dt\_6.6**

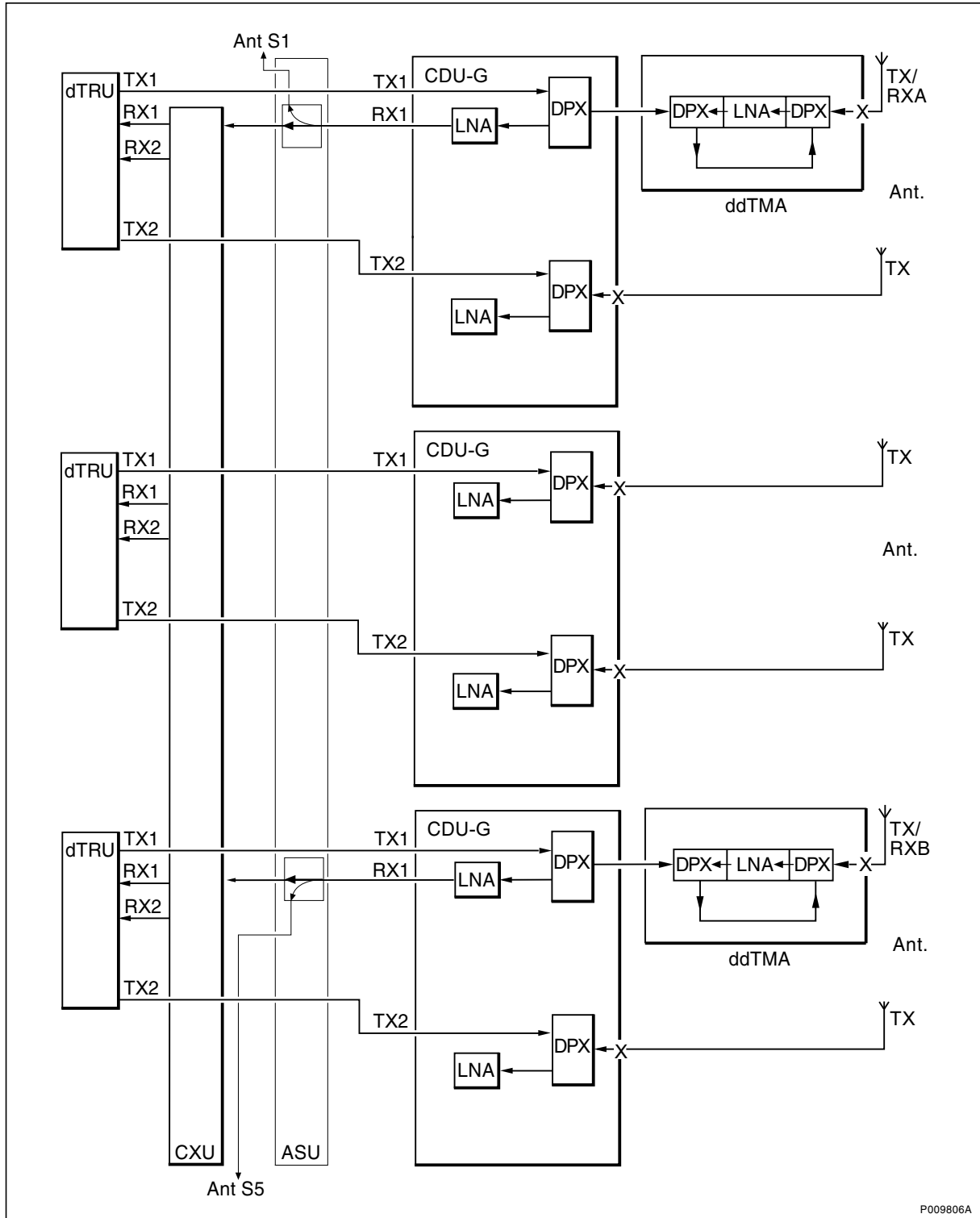

Figure 21 G8dt\_6.6, G9dt\_6.6, G18dt\_6.6 and G19dt\_6.6

**Characteristics**

Number of CDUs	3	
Frequency band	GSM 800	(G8dt_6.6)
	E-GSM	(G9dt_6.6)
	GSM 1800	(G18dt_6.6)
	GSM 1900	(G19dt_6.6)
Max. number of TRXs	6	
Number of feeders	6	
Number of antennas	6	
Antenna configuration	TX/RX + TX + TX + TX + TX/RX + TX	
TMA configuration	ddTMA + ddTMA	

**Note:** The ASU is optional equipment.



### Basic Configuration G8dh\_2.4, G9dh\_2.4, G18dh\_2.4 and G19dh\_2.4

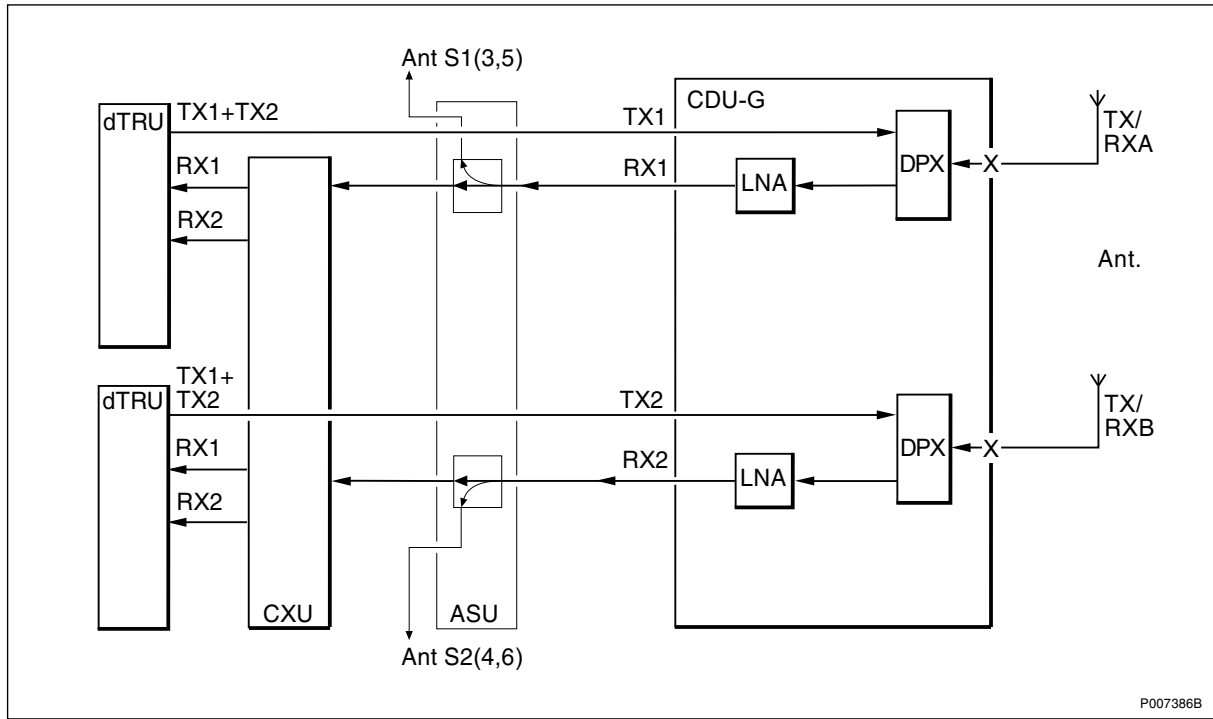

Figure 22 G8dh\_2.4, G9dh\_2.4, G18dh\_2.4 and G19dh\_2.4

#### Characteristics

Number of CDUs	1	
Frequency band	GSM 800	(G8dh_2.4)
	E-GSM	(G9dh_2.4)
	GSM 1800	(G18dh_2.4)
	GSM 1900	(G19dh_2.4)
Max. number of TRXs	4	
Number of feeders	2	
Number of antennas	2	
Antenna configuration	TX/RX + TX/RX	

**Note:** The ASU is optional equipment.

**Basic Configuration G8dht\_2.4, G9dht\_2.4, G18dht\_2.4 and G19dht\_2.4**

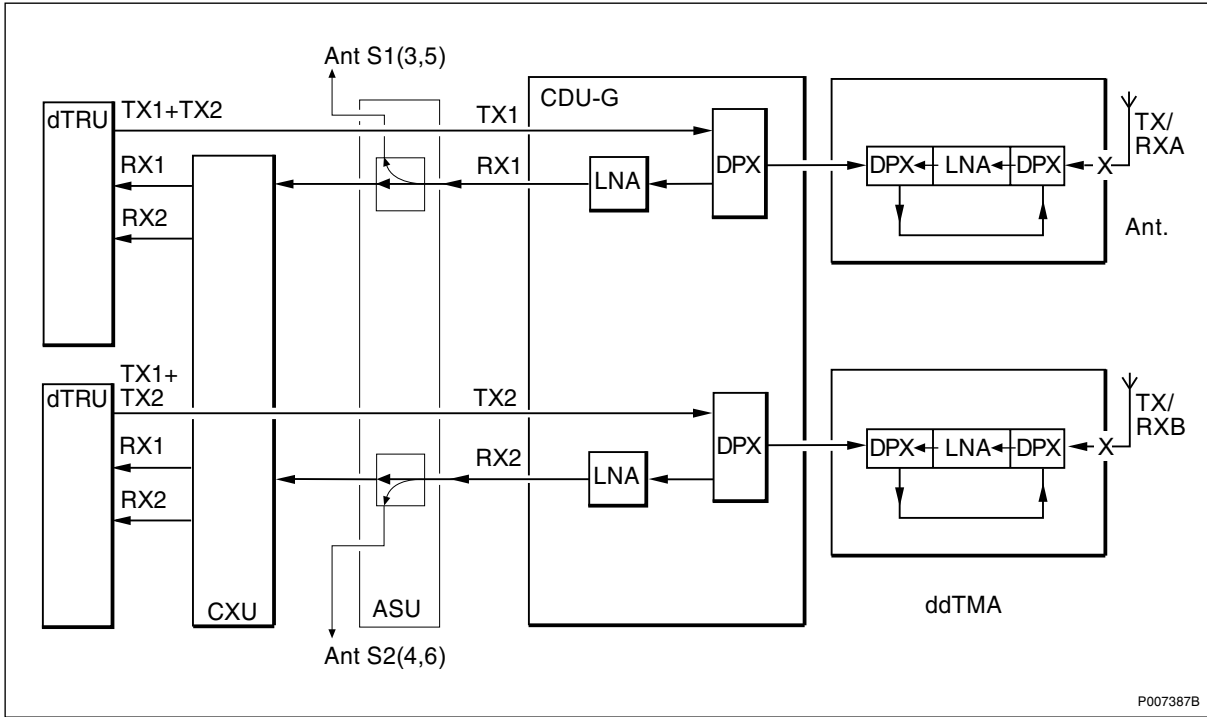

Figure 23 G8dht\_2.4, G9dht\_2.4, G18dht\_2.4 and G19dht\_2.4

**Characteristics**

Number of CDUs	1	
Frequency band	GSM 800	(G8dht_2.4)
	E-GSM	(G9dht_2.4)
	GSM 1800	(G18dht_2.4)
	GSM 1900	(G19dht_2.4)
Max. number of TRXs	4	
Number of feeders	2	
Number of antennas	2	
Antenna configuration	TX/RX + TX/RX	
TMA configuration	ddTMA + ddTMA	

**Note:** The ASU is optional equipment.

**Basic Configuration G8dh\_3.6, G9dh\_3.6, G18dh\_3.6 and G19dh\_3.6**

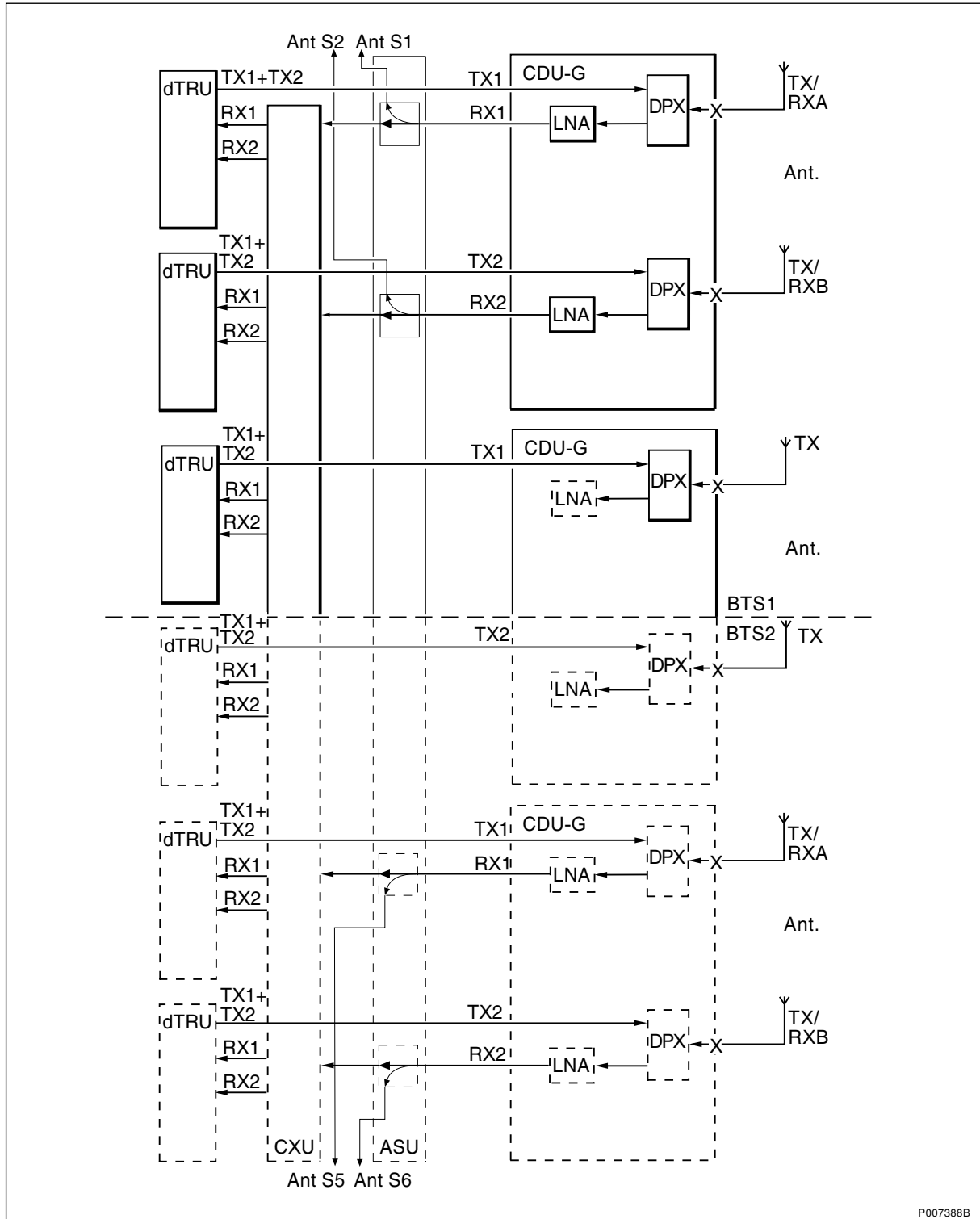

P007388B

Figure 24 G8dh\_3.6, G9dh\_3.6, G18dh\_3.6 and G19dh\_3.6

**Characteristics**

Number of CDUs	2*	
Frequency band	GSM 800	(G8dh_3.6)
	E-GSM	(G9dh_3.6)
	GSM 1800	(G18dh_3.6)
	GSM 1900	(G19dh_3.6)
Max. number of TRXs	6	
Number of feeders	3	
Number of antennas	3	
Antenna configuration	TX/RX + TX/RX + TX	

\* Three CDU-Gs support two sectors.

**Note:** The second BTS is only shown to illustrate a 2 x 6 configuration. BTS1 and BTS2 are two different physical implementations of the same basic configuration.

**Note:** The ASU is optional equipment.

**Basic Configuration G8dht\_3.6, G9dht\_3.6, G18dht\_3.6 and G19dht\_3.6**

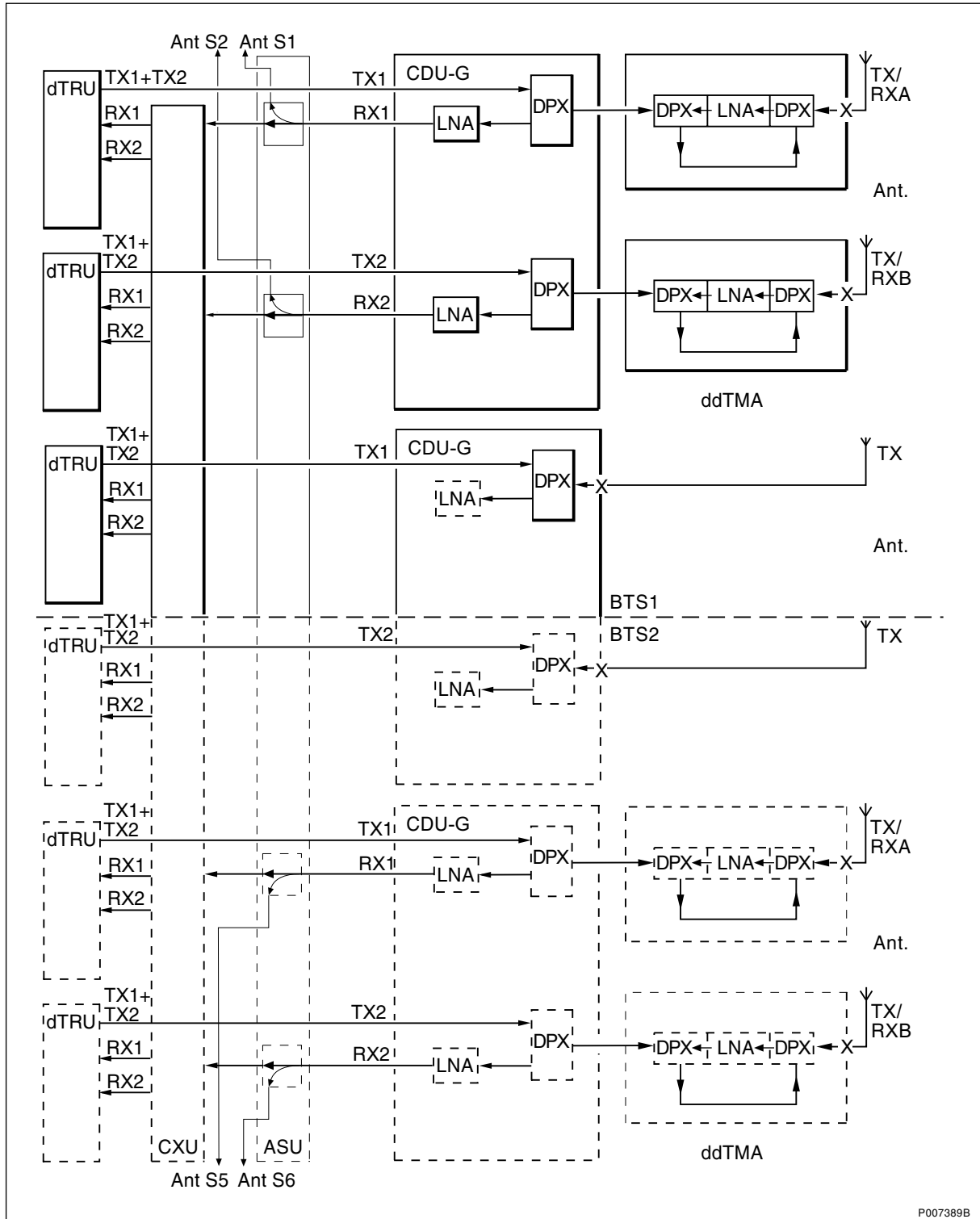

Figure 25 G8dht\_3.6, G9dht\_3.6, G18dh\_3.6 and G19dh\_3.6

**Characteristics**

Number of CDUs	2*	
Frequency band	GSM 800	(G8dht_3.6)
	E-GSM	(G9dht_3.6)
	GSM 1800	(G18dht_3.6)
	GSM 1900	(G19dht_3.6)
Max. number of TRXs	6	
Number of feeders	3	
Number of antennas	3	
Antenna configuration	TX/RX + TX/RX + TX	
TMA configuration	ddTMA + ddTMA	

\* Three CDU-Gs support two sectors.

**Note:** The second BTS is only shown to illustrate a 2 x 6 configuration. BTS1 and BTS2 are two different physical implementations of the same basic configuration.

**Note:** The ASU is optional equipment.

**Basic Configuration G8dh\_4.8, G9dh\_4.8, G18dh\_4.8 and G19dh\_4.8**

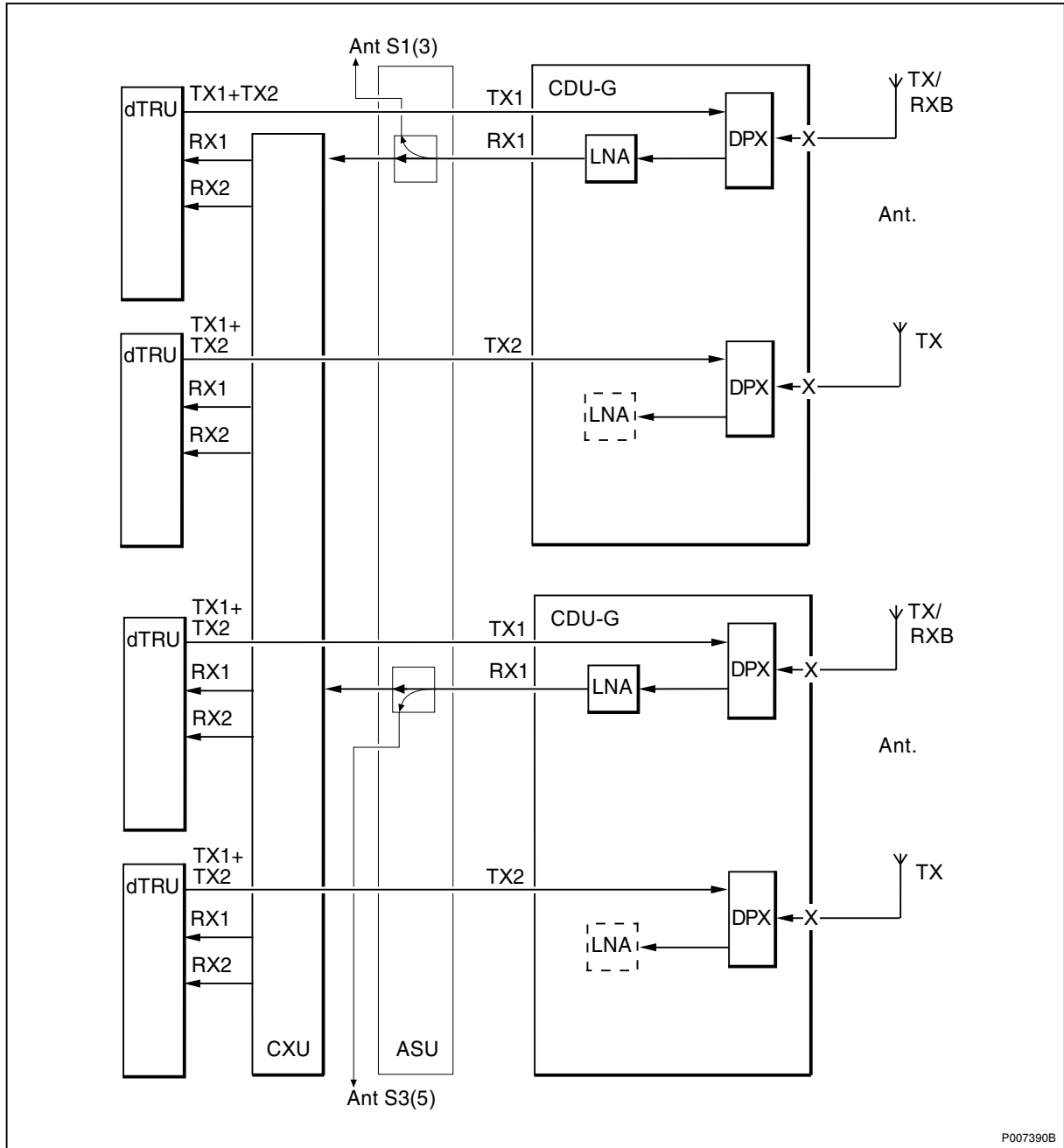

Figure 26 G8dh\_4.8, G9dh\_4.8, G18dh\_4.8 and G19dh\_4.8

**Characteristics**

Number of CDUs	2	
Frequency band	GSM 800	(G8dh_4.8)
	E-GSM	(G9dh_4.8)
	GSM 1800	(G18dh_4.8)
	GSM 1900	(G19dh_4.8)
Max. number of TRXs	8	
Number of feeders	4	
Number of antennas	4	
Antenna configuration	TX/RX + TX + TX/RX + TX	

**Note:** The ASU is optional equipment.



**Basic Configuration G8dht\_4.8, G9dht\_4.8, G18dht\_4.8 and G19dht\_4.8**

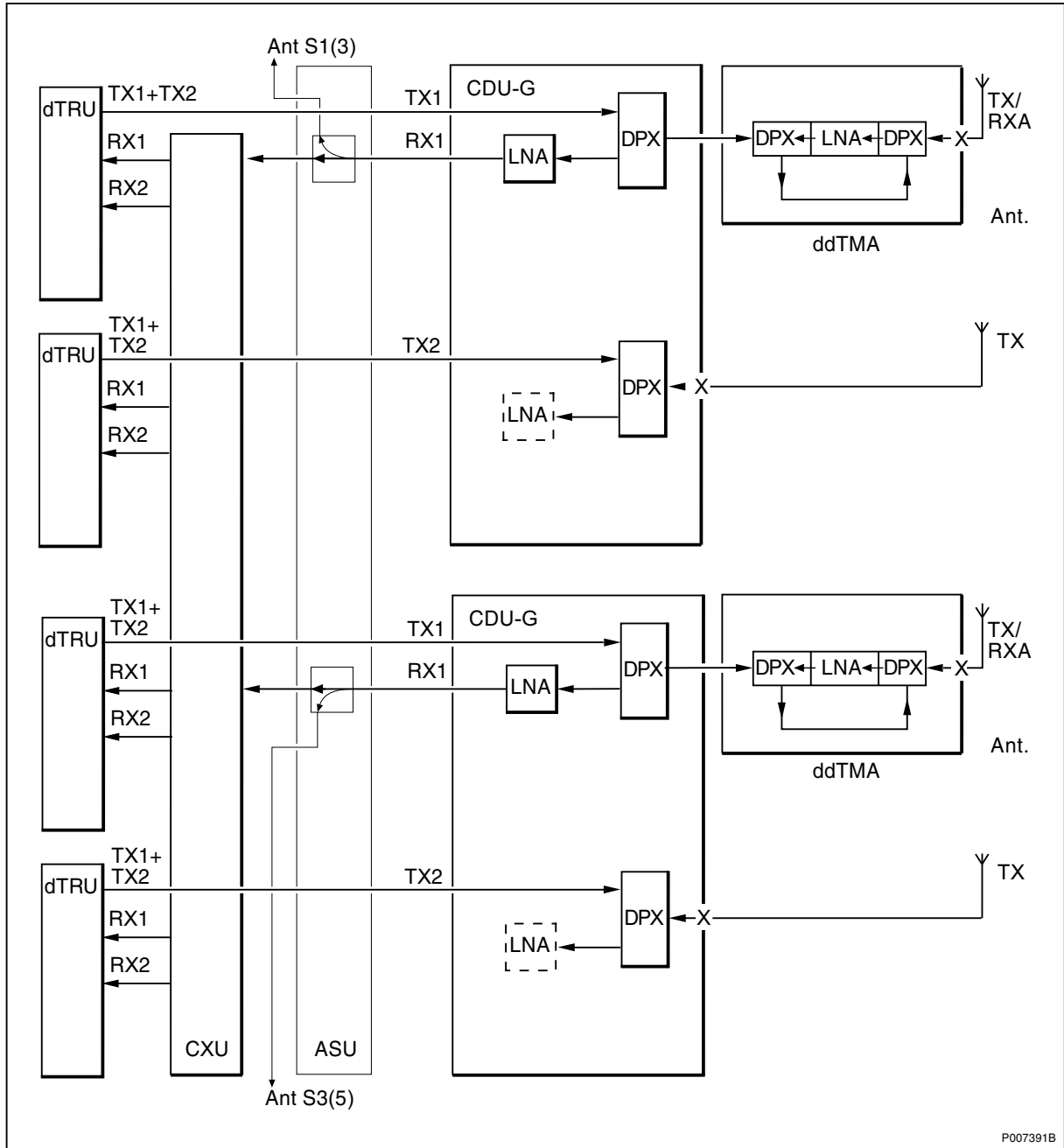

Figure 27 G8dht\_4.8, G9dht\_4.8, G18dht\_4.8 and G19dht\_4.8

**Characteristics**

Number of CDUs	2	
Frequency band	GSM 800	(G8dht_4.8)
	E-GSM	(G9dht_4.8)
	GSM 1800	(G18dht_4.8)
	GSM 1900	(G19dht_4.8)
Max. number of TRXs	8	
Number of feeders	4	
Number of antennas	4	
Antenna configuration	TX/RX + TX + TX/RX + TX	
TMA configuration	ddTMA + ddTMA	

**Note:** The ASU is optional equipment.

**Basic Configuration G8dh\_6.12, G9dh\_6.12, G18dh\_6.12 and G19dh\_6.12**

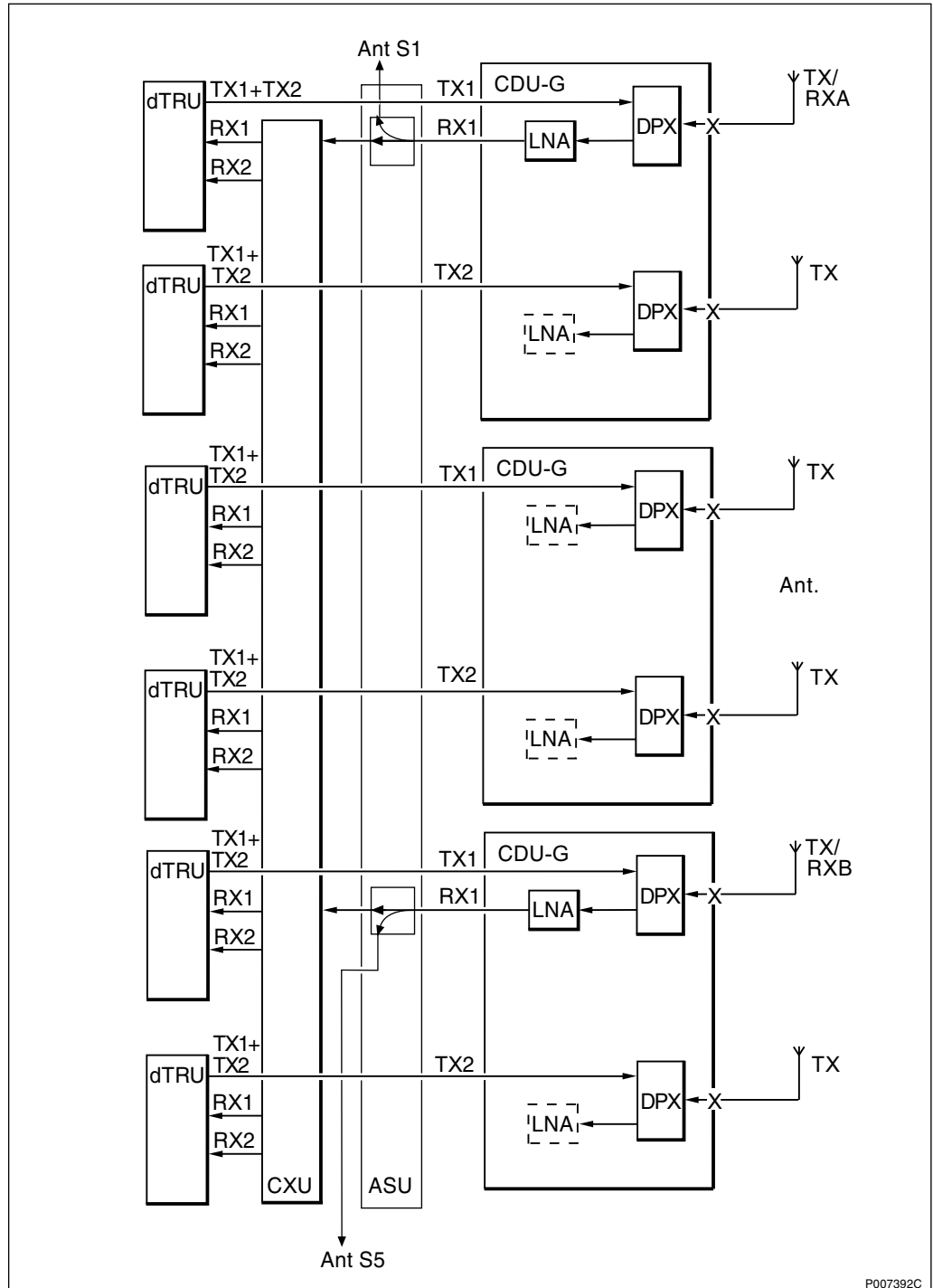

Figure 28 G8dh\_6.12, G9dh\_6.12, G18dh\_6.12 and G19dh\_6.12

**Characteristics**

Number of CDUs	3	
Frequency band	GSM 800	(G8dh_6.12)
	E-GSM	(G9dh_6.12)
	GSM 1800	(G18dh_6.12)
	GSM 1900	(G19dh_6.12)
Max. number of TRXs	12	
Number of feeders	6	
Number of antennas	6	
Antenna configuration	2 x TX/RX + 4 x TX	

**Note:** The ASU is optional equipment.

**Basic Configuration G8dht\_6.12, G9dht\_6.12, G18dht\_6.12 and G19dht\_6.12**

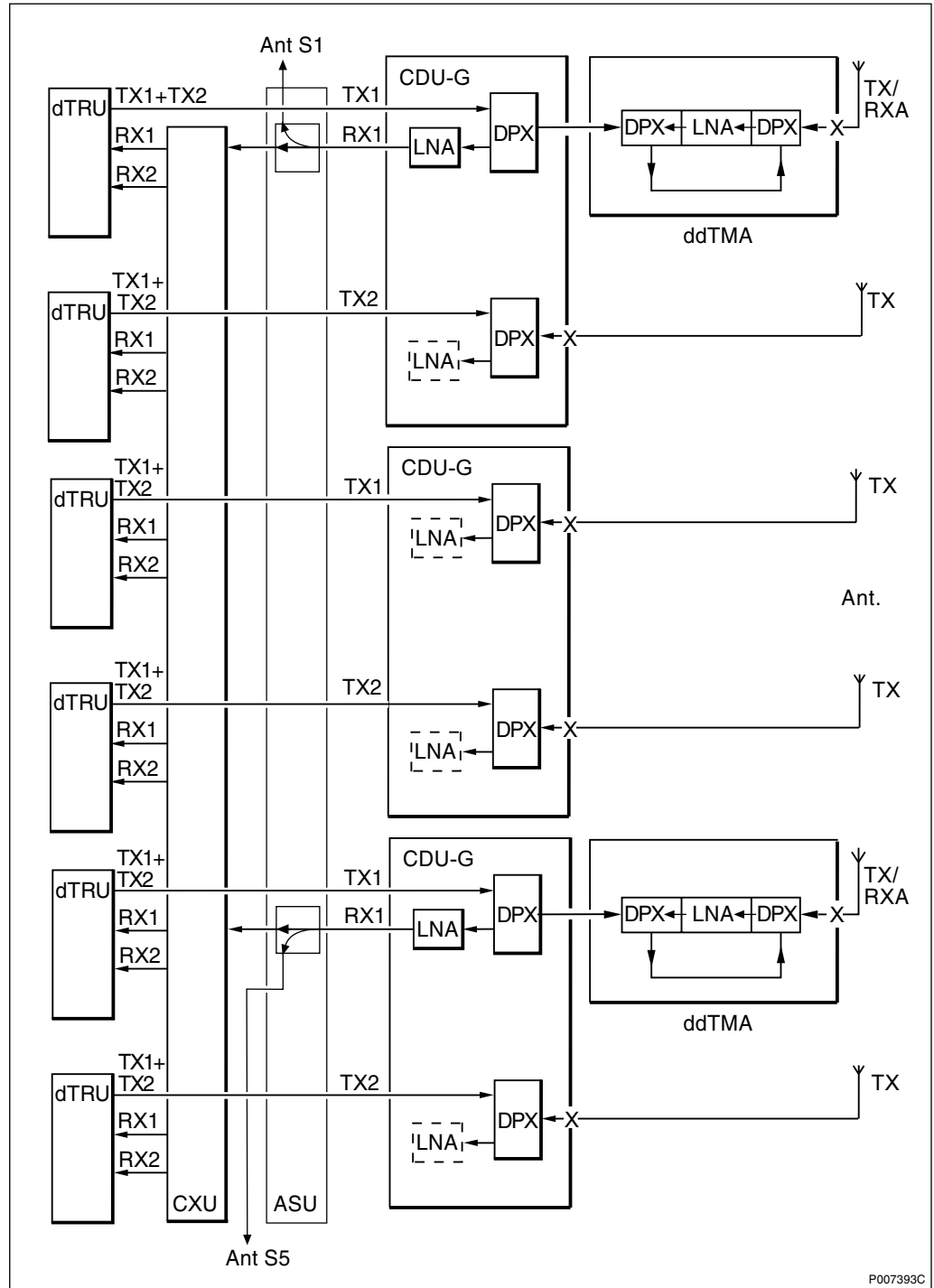

Figure 29 G8dht\_6.12, G9dht\_6.12, G18dht\_6.12 and G19dht\_6.12

**Characteristics**

Number of CDUs	3	
Frequency band	GSM 800	(G8dht_6.12)
	E-GSM	(G9dht_6.12)
	GSM 1800	(G18dht_6.12)
	GSM 1900	(G19dht_6.12)
Max. number of TRXs	12	
Number of feeders	6	
Number of antennas	6	
Antenna configuration	2 x TX/RX + 4 x TX	
TMA configuration	ddTMA + ddTMA	

**Note:** The ASU is optional equipment.

**5.4****RX Connection from Antenna to dTRU**

Connection in the RX path is performed using the CXU. It varies, depending on the basic configurations used and the position in the cabinet. To avoid having to change cables for different configurations, the connections are set up automatically by the software.

The TX antenna connections are independent of the CXU.

The tables below show how TMAs and their associated bias injectors are connected to configurations using TMAs.

*Table 1 1 x 12 configurations with CDU-F*

<b>CDU No. / Connector</b>	<b>TMA No. (TMA config. only)</b>	<b>Antenna</b>
1 / TX/RX	1	TX/RXA
3 / TX/RX	5	TX/RXB

Table 2 1 x 12 combined and 1 x 6 uncombined configurations with CDU-G

CDU No. / Connector	Antenna Sharing Connector (Co-siting only)	TMA No. (TMA config. only)	Antenna
1 / TX/RX1	1	1	TX/RXA
3 / TX/RX1	5	5	TX/RXB

Table 3 1 + 1 + 2 configurations with CDU-G

Cell	CDU No. / Connector	Antenna Sharing Connector (Co-siting only)	TMA	Antenna
1	1 / TX/RX1	1	1	TX/RXA
	2 / TX/RX1	3	3	RXB
2	1 / TX/RX2	2	2	TX/RXA
	2 / TX/RX2	4	4	RXB
3	3 / TX/RX1	5	5	TX/RXA
	3 / TX/RX2	6	6	TX/RXB

Table 4 2 x 6 configurations with CDU-F

Cell	CDU No. / Connector	TMA No. (TMA config. only)	Antenna
1	1 / TX/RX	1	TX/RXA
	1 / RX	2	RXB
2	3 / TX/RX	5	TX/RXA
	3 / RX	6	RXB

*Table 5 2 x 6 configurations with CDU-G*

<b>Cell</b>	<b>CDU No. / Connector</b>	<b>Antenna Sharing Connector (Co-siting only)</b>	<b>TMA No. (TMA config. only)</b>	<b>Antenna</b>
1	1 / TX/RX1	1	1	TX/RXA
	1 / TX/RX2	2	2	TX/RXB
2	3 / TX/RX1	5	5	TX/RXA
	3 / TX/RX2	6	6	TX/RXB

*Table 6 3 x 4 configurations with CDU-F*

<b>Cell</b>	<b>CDU No. / Connector</b>	<b>TMA No. (TMA config. only)</b>	<b>Antenna</b>
1	1 / TX/RX	1	TX/RXA
	1 / RX	2	RXB
2	2 / TX/RX	3	TX/RXA
	2 / RX	4	RXB
3	3 / TX/RX	5	TX/RXA
	3 / RX	6	RXB



*Table 7 3 x 4 combined and 3 x 2 uncombined configurations with CDU-G*

<b>Cell</b>	<b>CDU No. / Connector</b>	<b>Antenna Sharing Connector (Co-siting only)</b>	<b>TMA No. (TMA config. only)</b>	<b>An- tenna</b>
1	1 / TX/RX1	1	1	TX/RXA
	1 / TX/RX2	2	2	TX/RXB
2	2 / TX/RX1	3	3	TX/RXA
	2 / TX/RX2	4	4	TX/RXB
3	3 / TX/RX1	5	5	TX/RXA
	3 / TX/RX2	6	6	TX/RXB

*Table 8 1 x 8 configurations with CDU-F*

<b>Cell</b>	<b>CDU No. / Connector</b>	<b>TMA No. (TMA config. only)</b>	<b>Antenna</b>
1	1 / TX/RX	1	TX/RXA
	2 / TX/RX	3	TX/RXB
Alt. 1	2/ TX/RX	3	TX/RXA
	3 / TX/RX	5	TX/RXB

*Table 9 1 x 8 combined and 1 x 4 uncombined configurations with CDU-G*

<b>Cell</b>	<b>CDU  No. / Connector</b>	<b>Antenna Sharing Connector  (Co-siting only)</b>	<b>TMA  No. (TMA config. only)</b>	<b>Antenna</b>
1	1 / TX/RX1	1	1	TX/RXA
	2 / TX/RX1	3	3	TX/RXB
Alt.1	2 / TX/RX1	3	3	TX/RXA
	3 / TX/RX1	5	5	TX/RXB

**Note:** It is only possible to have one 1 x 8 configuration in the cabinet. One 1 x 8 configuration can be combined with one 1 x 4 configuration.

## 6 Site Cell Configurations (SCC)

The following section shows SCCs in one RBS. More RBSs can be combined to form larger configurations at a site. Possible expansions, where different RBSs are connected using TG-synchronization, are described in *Section 7 on page 78*.

The following SCCs are supported by the RBS:

- specified basic radio configurations
- the RBS with any number of dTRUs within the specified range inserted in the specified position order.

## 6.1 RBS 2106 and RBS 2206 Configurations

### CDU-F Single Band Configurations

Table 10 CDU-F configurations with a fully-equipped cabinet

SCC	Configuration	TMA			Number of Antennas			Allowed Number of dTRUs		
		Cell or sector:			Cell or sector:			Cell or sector:		
		1	2	3	1	2	3	1	2	3
1 x 12	F9d_2.12	No	N/A	N/A	2	N/A	N/A	0-6	N/A	N/A
	F9dt_2.12	M	N/A	N/A	2	N/A	N/A	0-6	N/A	N/A
	F18d_2.12	No	N/A	N/A	2	N/A	N/A	0-6	N/A	N/A
	F18dt_2.12	M	N/A	N/A	2	N/A	N/A	0-6	N/A	N/A
2 x 6	2 x F9d_2.6	No	No	N/A	2	2	N/A	0-3	0-3	N/A
	2 x F9dt_2.6	M	M	N/A	2	2	N/A	0-3	0-3	N/A
	2 x F18d_2.6	No	No	N/A	2	2	N/A	0-3	0-3	N/A
	2 x F18dt_2.6	M	M	N/A	2	2	N/A	0-3	0-3	N/A
3 x 4	3 x F9d_2.4	No	No	No	2	2	2	0-2	0-2	0-2
	3 x F9dt_2.4	M	M	M	2	2	2	0-2	0-2	0-2
	3 x F18d_2.4	No	No	No	2	2	2	0-2	0-2	0-2
	3 x F18dt_2.4	M	M	M	2	2	2	0-2	0-2	0-2
1 x 8 + 1 x 4	F9d_2.8 + F9d_2.4	No	No	N/A	2	2	N/A	0-4	0-2	N/A
	F9dt_2.8 + F9dt_2.4	M	M	N/A	2	2	N/A	0-4	0-2	N/A
	F18d_2.8 + F18d_2.4	No	No	N/A	2	2	N/A	0-4	0-2	N/A
	F18dt_2.8 + F18dt_2.4	M	M	N/A	2	2	N/A	0-4	0-2	N/A
1 x 4 + 1 x 8	F9d_2.4 + F9d_2.8	No	No	N/A	2	2	N/A	0-2	0-4	N/A
	F9dt_2.4 + F9dt_2.8	M	M	N/A	2	2	N/A	0-2	0-4	N/A
	F18d_2.4 + F18d_2.8	No	No	N/A	2	2	N/A	0-2	0-4	N/A
	F18dt_2.4 + F18dt_2.8	M	M	N/A	2	2	N/A	0-2	0-4	N/A

M = Mandatory

N/A = Not Applicable

The following configurations are also possible:

<b>SCC 1 x 2</b>	SCC 1 x 2 can be achieved as a subset of SCC 3 x 4 or 2 x 6. It requires one CDU-F.
<b>SCC 2 x 2</b>	SCC 2 x 2 can be achieved as a subset of SCC 3 x 4 or 2 x 6. It requires two CDU-Fs.
<b>SCC 2 x 4</b>	SCC 2 x 4 can be achieved as a subset of SCC 3 x 4 or 2 x 6. It requires two CDU-Fs.
<b>SCC 3 x 2</b>	SCC 3 x 2 can be achieved as a subset of SCC 3 x 4. It requires three CDU-Fs.
<b>SCC 1 x 4</b>	SCC 1 x 4 can be achieved as a subset of either SCC 3 x 4 or 2 x 6. It requires one CDU-F.
<b>SCC 1 x 6</b>	SCC 1 x 6 can be achieved as a subset of SCC 2 x 6 or 1 x 12. It requires two CDU-Fs.

Table 11 CDU-F configurations with a partly-equipped cabinet

SCC	Configuration	TMA			Number of Antennas <sup>1)</sup>			Allowed Number of dTRUs <sup>2)</sup>		
		Cell or sector:			Cell or sector:			Cell or sector:		
		1	2	3	1	2	3	1	2	3
1 x 4	F9d_2.4	No	No	No	2	0	0	0-2	0	0
	F9dt_2.4	M	M	M	2	0	0	0-2	0	0
	F18d_2.4	No	No	No	2	0	0	0-2	0	0
	F18dt_2.4	M	M	M	2	0	0	0-2	0	0
2 x 4	2 x F9d_2.4	No	No	No	2	2	0	0-2	0-2	0
	2 x F9dt_2.4	M	M	M	2	2	0	0-2	0-2	0
	2 x F18d_2.4	No	No	No	2	2	0	0-2	0-2	0
	2 x F18dt_2.4	M	M	M	2	2	0	0-2	0-2	0
1 x 8	F9d_2.8	No	No	N/A	2	0	N/A	0-4	0	N/A
	F9dt_2.8	M	M	N/A	2	0	N/A	0-4	0	N/A
	F18d_2.8	No	No	N/A	2	0	N/A	0-4	0	N/A
	F18dt_2.8	M	M	N/A	2	0	N/A	0-4	0	N/A

M = Mandatory

N/A = Not Applicable

<sup>1)</sup> "0" in these columns indicates that antennas can be added if the site is expanded with more sectors.

<sup>2)</sup> "0" in these columns indicates that space exists in the cabinet for future site expansion.

### CDU-G Single Band Configurations without Hybrid Combiner

Table 12 CDU-G configurations without hybrid combiner in a fully or partly-equipped cabinet

SCC	Configuration	TMA			Number of Antennas			Allowed Number of dTRUs		
		Cell or sector:			Cell or sector:			Cell or sector:		
		1	2	3	1	2	3	1	2	3
3 x 2	3 x G8d_2.2	No	No	No	2	2	2	0-1	0-1	0-1
	3 x G8dt_2.2	M	M	M	2	2	2	0-1	0-1	0-1
	3 x G9d_2.2	No	No	No	2	2	2	0-1	0-1	0-1
	3 x G9dt_2.2	M	M	M	2	2	2	0-1	0-1	0-1
	3 x G18d_2.2	No	No	No	2	2	2	0-1	0-1	0-1
	3 x G18dt_2.2	M	M	M	2	2	2	0-1	0-1	0-1
	3 x G19d_2.2	No <sup>1)</sup>	No <sup>1)</sup>	No <sup>1)</sup>	2	2	2	0-1	0-1	0-1
3 x G19dt_2.2	M <sup>1)</sup>	M <sup>1)</sup>	M <sup>1)</sup>	2	2	2	0-1	0-1	0-1	
1 x 6	G8d_6.6	No	N/A	N/A	6	N/A	N/A	0-3	N/A	N/A
	G9d_6.6	No	N/A	N/A	6	N/A	N/A	0-3	N/A	N/A
	G9dt_6.6	M	N/A	N/A	6	N/A	N/A	0-3	N/A	N/A
	G18d_6.6	No	N/A	N/A	6	N/A	N/A	0-3	N/A	N/A
	G18dt_6.6	M	N/A	N/A	6	N/A	N/A	0-3	N/A	N/A
	G19d_6.6	No	N/A	N/A	6	N/A	N/A	0-3	N/A	N/A
	G19dt_6.6	M	N/A	N/A	6	N/A	N/A	0-3	N/A	N/A

M = Mandatory

N/A = Not Applicable

<sup>1)</sup> It is possible to mix cells with TMA and cells without TMA at the same site.

Table 13 CDU-G configurations without hybrid combiner in a partly-equipped cabinet only

SCC	Configuration	TMA			Number of Antennas <sup>1)</sup>			Allowed No. of dTRUs <sup>2)</sup>		
		Cell or Sector:			Cell or Sector:			Cell or Sector:		
		1	2	3	1	2	3	1	2	3
1 + 1	2 x G8d_2.1	No	No	No	2	2	0	0 or 1	0	0
	2 x G8dt_2.1	M	M	M	2	2	0	0 or 1	0	0
	2 x G9d_2.1	No	No	No	2	2	0	0 or 1	0	0
	2 x G9dt_2.1	M	M	M	2	2	0	0 or 1	0	0
	2 x G18d_2.1	No	No	No	2	2	0	0 or 1	0	0
	2 x G18dt_2.1	M	M	M	2	2	0	0 or 1	0	0
	2 x G19d_2.1	No <sub>3)</sub>	No <sub>3)</sub>	No <sub>3)</sub>	2	2	0	0 or 1	0	0
2 x G19dt_2.1	M <sub>3)</sub>	M <sub>3)</sub>	M <sub>3)</sub>	2	2	0	0 or 1	0	0	
1 + 1 + 2	2 x G8d_2.1 + G8d_2.2	No	No	No	2	2	2	0 or 1	0	0 or 1
	2 x G8dt_2.1 + G8dt_2.2	M	M	M	2	2	2	0 or 1	0	0 or 1
	2 x G9d_2.1 + G9d_2.2	No	No	No	2	2	2	0 or 1	0	0 or 1
	2 x G9dt_2.1 + G9dt_2.2	M	M	M	2	2	2	0 or 1	0	0 or 1
	2 x G18d_2.1 + G18d_2.2	No	No	No	2	2	2	0 or 1	0	0 or 1
	2 x G18dt_2.1 + G18dt_2.2	M	M	M	2	2	2	0 or 1	0	0 or 1
	2 x G19d_2.1 + G19d_2.2	No <sub>3)</sub>	No <sub>3)</sub>	No <sub>3)</sub>	2	2	2	0 or 1	0	0 or 1
2 x G19dt_2.1 + G19dt_2.2	M <sub>3)</sub>	M <sub>3)</sub>	M <sub>3)</sub>	2	2	2	0 or 1	0	0 or 1	



Table 13 CDU-G configurations without hybrid combiner in a partly-equipped cabinet only

SCC	Configuration	TMA			Number of Antennas <sup>1)</sup>			Allowed No. of dTRUs <sup>2)</sup>		
		Cell or Sector:			Cell or Sector:			Cell or Sector:		
		1	2	3	1	2	3	1	2	3
1 x 2	G8d_2.2	No	No	No	2	0	0	0 or 1	0	0
	G8dt_2.2	M	M	M	2	0	0	0 or 1	0	0
	G9d_2.2	No	No	No	2	0	0	0 or 1	0	0
	G9dt_2.2	M	M	M	2	0	0	0 or 1	0	0
	G18d_2.2	No	No	No	2	0	0	0 or 1	0	0
	G18dt_2.2	M	M	M	2	0	0	0 or 1	0	0
	G19d_2.2	No	No	No	2	0	0	0 or 1	0	0
	G19dt_2.2	M	M	M	2	0	0	0 or 1	0	0
1 x 4	G8d_4.4	No	No	No	4	0	0	0-2	0	0
	G9d_4.4	No	No	No	4	0	0	0-2	0	0
	G9dt_4.4	M	M	M	4	0	0	0-2	0	0
	G18d_4.4	No	No	No	4	0	0	0-2	0	0
	G18dt_4.4	M	M	M	4	0	0	0-2	0	0
	G19d_4.4	No	No	No	4	0	0	0-2	0	0
	G19dt_4.4	M	M	M	4	0	0	0-2	0	0
	2 x 2	2 x G8d_2.2	No	No	No	2	2	0	0 or 1	0 or 1
2 x G8dt_2.2		M	M	M	2	2	0	0 or 1	0 or 1	0
2 x G9d_2.2		No	No	No	2	2	0	0 or 1	0 or 1	0
2 x G9dt_2.2		M	M	M	2	2	0	0 or 1	0 or 1	0
2 x G18d_2.2		No	No	No	2	2	0	0 or 1	0 or 1	0
2 x G18dt_2.2		M	M	M	2	2	0	0 or 1	0 or 1	0
2 x G19d_2.2		No <sup>3)</sup>	No <sup>3)</sup>	No <sup>3)</sup>	2	2	0	0 or 1	0 or 1	0
2 x G19dt_2.2		M <sup>3)</sup>	M <sup>3)</sup>	M <sup>3)</sup>	2	2	0	0 or 1	0 or 1	0

M = Mandatory

N/A = Not Applicable

1) "0" in these columns indicates that antennas can be added if the site is expanded with more sectors.

2) "0" in these columns indicates that space exists in the cabinet for future site expansion.

3) It is possible to mix cells with TMA and cells without TMA at the same site.

### CDU-G Single Band Configuration with Hybrid Combiner

*Table 14 CDU-G configurations with hybrid combiner in a fully- or partly-equipped cabinet*

SCC	Configuration	TMA			Number of Antennas			Allowed Number of dTRUs		
		Cell or Sector:			Cell or Sector:			Cell or Sector:		
		1	2	3	1	2	3	1	2	3
3 x 4	3 x G8dh_2.4	No	No	No	2	2	2	0-2	0-2	0-2
	3 x G8dht_2.4	M	M	M	2	2	2	0-2	0-2	0-2
	3 x G9dh_2.4	No	No	No	2	2	2	0-2	0-2	0-2
	3 x G9dht_2.4	M	M	M	2	2	2	0-2	0-2	0-2
	3 x G18dh_2.4	No	No	No	2	2	2	0-2	0-2	0-2
	3 x G18dht_2.4	M	M	M	2	2	2	0-2	0-2	0-2
	3 x G19dh_2.4	No <sup>1)</sup>	No <sup>1)</sup>	No <sup>1)</sup>	2	2	2	0-2	0-2	0-2
	3 x G19dht_2.4	M <sup>1)</sup>	M <sup>1)</sup>	M <sup>1)</sup>	2	2	2	0-2	0-2	0-2
2 x 6	2 x G8dh_3.6	No	No	N/A	3	3	N/A	0-3	0-3	N/A
	2 x G8dht_3.6	M	M	N/A	3	3	N/A	0-3	0-3	N/A
	2 x G9dh_3.6	No	No	N/A	3	3	N/A	0-3	0-3	N/A
	2 x G9dht_3.6	M	M	N/A	3	3	N/A	0-3	0-3	N/A
	2 x G18dh_3.6	No	No	N/A	3	3	N/A	0-3	0-3	N/A
	2 x G18dht_3.6	M	M	N/A	3	3	N/A	0-3	0-3	N/A
	2 x G19dh_3.6	No <sup>1)</sup>	No <sup>1)</sup>	N/A	3	3	N/A	0-3	0-3	N/A
	2 x G19dht_3.6	M <sup>1)</sup>	M <sup>1)</sup>	N/A	3	3	N/A	0-3	0-3	N/A
1 x 12	G8dh_6.12	No	N/A	N/A	6	N/A	N/A	0-6	N/A	N/A
	G8dht_6.12	M	N/A	N/A	6	N/A	N/A	0-6	N/A	N/A
	G9dh_6.12	No	N/A	N/A	6	N/A	N/A	0-6	N/A	N/A
	G9dht_6.12	M	N/A	N/A	6	N/A	N/A	0-6	N/A	N/A
	G18dh_6.12	No	N/A	N/A	6	N/A	N/A	0-6	N/A	N/A
	G18dht_6.12	M	N/A	N/A	6	N/A	N/A	0-6	N/A	N/A
	G19dh_6.12	No	N/A	N/A	6	N/A	N/A	0-6	N/A	N/A
	G19dht_6.12	M	N/A	N/A	6	N/A	N/A	0-6	N/A	N/A

M = Mandatory

N/A = Not Applicable

<sup>1)</sup> It is possible to mix cells with TMA and cells without TMA at the same site.

The following configurations are also possible:

<b>SCC 1 x 2</b>	This can be achieved as a subset of SCC 3 x 4. It requires one CDU-G.
<b>SCC 2 x 2</b>	This can be achieved as a subset of SCC 3 x 4. It requires two CDU-Gs.
<b>SCC 3 x 2</b>	This can be achieved as a subset of SCC 3 x 4. It requires three CDU-Gs.
<b>SCC 1 x 4</b>	This can be achieved as a subset of either SCC 3 x 4 or 2 x 6. It requires one CDU-G.
<b>SCC 2 x 4</b>	This can be achieved as a subset of SCC 3 x 4 or 2 x 6.
<b>SCC 1 x 6</b>	This can be achieved as a subset of SCC 2 x 6. It requires two CDU-Gs.

Table 15 CDU-G configurations with hybrid combiner in a partly-equipped cabinet only

SCC	Configuration	TMA			Number of Antennas <sup>1)</sup>			Allowed Number of dTRUs <sup>2)</sup>		
		Cell or section:			Cell or section:			Cell or section:		
		1	2	3	1	2	3	1	2	3
1 x 4	G8dh_2.4	No	No	No	2	0	0	0-2	0	0
	G8dht_2.4	M	M	M	2	0	0	0-2	0	0
	G9dh_2.4	No	No	No	2	0	0	0-2	0	0
	G9dht_2.4	M	M	M	2	0	0	0-2	0	0
	G18dh_2.4	No	No	No	2	0	0	0-2	0	0
	G18dht_2.4	M	M	M	2	0	0	0-2	0	0
	G19dh_2.4	No	No	No	2	0	0	0-2	0	0
	G19dht_2.4	M	M	M	2	0	0	0-2	0	0
2 x 4	2 x G8dh_2.4	No	No	No	2	2	0	0-2	0-2	0
	2 x G8dht_2.4	M	M	M	2	2	0	0-2	0-2	0
	2 x G9dh_2.4	No	No	No	2	2	0	0-2	0-2	0
	2 x G9dht_2.4	M	M	M	2	2	0	0-2	0-2	0
	2 x G18dh_2.4	No	No	No	2	2	0	0-2	0-2	0
	2 x G18dht_2.4	M	M	M	2	2	0	0-2	0-2	0
	2 x G19dh_2.4	No <sup>3)</sup>	No <sup>3)</sup>	No <sup>3)</sup>	2	2	0	0-2	0-2	0
	2 x G19dht_2.4	M <sup>3)</sup>	M <sup>3)</sup>	M <sup>3)</sup>	2	2	0	0-2	0-2	0
1 x 8	G8dh_4.8	No	No	N/A	4	0	N/A	0-4	0	N/A
	G8dht_4.8	M	M	N/A	4	0	N/A	0-4	0	N/A
	G9dh_4.8	No	No	N/A	4	0	N/A	0-4	0	N/A
	G9dht_4.8	M	M	N/A	4	0	N/A	0-4	0	N/A
	G18dh_4.8	No	No	N/A	4	0	N/A	0-4	0	N/A
	G18dht_4.8	M	M	N/A	4	0	N/A	0-4	0	N/A
	G19dh_4.8	No	No	N/A	4	0	N/A	0-4	0	N/A
	G19dht_4.8	M	M	N/A	4	0	N/A	0-4	0	N/A

M = Mandatory

N/A = Not Applicable

- 1) "0" in these columns indicates that antennas can be added if the site is expanded with more sectors.
- 2) "0" in these columns indicates that space exists in the cabinet for future site expansion.
- 3) It is possible to mix cells with TMA and cells without TMA at the same site.

## 6.2 RBS 2106 and RBS 2206 Dual Band Configurations

The notation for dual band configurations is done with the lower frequency (for example 900 MHz) configuration to the left and the higher frequency (for example 1800 MHz) configuration to the right, separated by the | symbol. This notation is valid regardless of the position in the cabinet.

### CDU-F Configurations for GSM 900 and GSM 1800

Table 16 Dual band configurations with CDU-F in a fully- or partly-equipped cabinet

SCC	Configura- tion	Frequency Band			TMA			Number of Anten- nas			Allowed Number of dTRUs		
		Cell or sector:			Cell or sector:			Cell or sector:			Cell or sector:		
		1	2	3	1	2	3	1	2	3	1	2	3
1x4   1x8	F9d_2.4   F18d_2.8	900	1800	—	No	No	—	2	2	—	0-2	0-4	—
	F9dt_2.4   F18dt_2.8	900	1800	—	M	M	—	2	2	—	0-2	0-4	—
1x8   1x4	F9d_2.8   F18d_2.4	900	1800	—	No	No	—	2	2	—	0-4	0-2	—
	F9dt_2.8   F18dt_2.4	900	1800	—	M	M	—	2	2	—	0-4	0-2	—
1x4   2x4	F9d_2.4   2 x F18d_2.4	900	1800	1800	No	No	No	2	2	2	0-2	0-2	0-2
	F9dt_2.4   2 x F18dt_2.4	900	1800	1800	M	M	M	2	2	2	0-2	0-2	0-2
2x4   1x4	2 x F9d_2.4   F18d_2.4	900	900	1800	No	No	No	2	2	2	0-2	0-2	0-2
	2 x F9dt_2.4   F18dt_2.4	900	900	1800	M	M	M	2	2	2	0-2	0-2	0-2

M = Mandatory

A dash (—) indicates that the cell or sector is not used in this configuration.

There are two options for placing the equipment in the cabinet: GSM 900 on the left-hand side/GSM 1800 on the right-hand side, or the other way round.

Table 17 Dual band configurations with CDU-F in a partly-equipped cabinet only

SCC	Configura- tion	Frequency Band			TMA			Number of Antennas			Allowed Number of dTRUs		
		Cell or sector:			Cell or sector:			Cell or sector:			Cell or sector:		
		1	2	3	1	2	3	1	2	3	1	2	3
1x4   1x4	F9d_2.4   F18d_2.4	900	1800	—	No	No	—	2	2	—	0–2	0–2	—
	F9dt_2.4   F18dt_2.4	900	1800	—	M	M	—	2	2	—	0–2	0–2	—

M = Mandatory

A dash (—) indicates that the cell or sector is not used in this configuration.

There are two options for placing the equipment in the cabinet: GSM 900 on the left-hand side/GSM 1800 on the right-hand side, or the other way round. In each case the middle positions are not used.



### CDU-G Configurations for GSM 900 and GSM 1800

Table 18 Dual band configurations, CDU-G with hybrid in a fully- or partly-equipped cabinet

SCC	Configuration	Frequency Band			TMA			Number of Antennas			Allowed Number of dTRUs		
		Cell or sector:			Cell or sector:			Cell or sector:			Cell or sector:		
		1	2	3	1	2	3	1	2	3	1	2	3
1x8   1x4	G9dh_4.8   G18dh_2.4	900	1800	—	No	No	—	4	2	—	0-4	0-2	—
	G9dht_4.8   G18dht_2.4	900	1800	—	M	M	—	4	2	—	0-4	0-2	—
1x4   1x8	G9dh_2.4   G18dh_4.8	900	1800	—	No	No	—	2	4	—	0-2	0-4	—
	G9dht_2.4   G18dht_4.8	900	1800	—	M	M	—	2	4	—	0-2	0-4	—
2x4   1x4	2 x G9dh_2.4   G18dh_2.4	900	900	1800	No	No	No	2	2	2	0-2	0-2	0-2
	2 x G9dht_2.4   G18dht_2.4	900	900	1800	M	M	M	2	2	2	0-2	0-2	0-2
1x4   2x4	G9dh_2.4   2 x G18dh_2.4	900	1800	1800	No	No	No	2	2	2	0-2	0-2	0-2
	G9dht_2.4   2 x G18dht_2.4	900	1800	1800	M	M	M	2	2	2	0-2	0-2	0-2

M = Mandatory

A dash (—) indicates that the cell or sector is not used in this configuration.

There are two options for placing the equipment in the cabinet: GSM 900 on the left-hand side/GSM 1800 on the right-hand side, or the other way round.

Table 19 Dual band configurations, CDU-G with hybrid in a partly-equipped cabinet only

SCC	Configura- tion	Frequency Band			TMA			Number of Antennas			Allowed Number of dTRUs		
		Cell or sector:			Cell or sector:			Cell or sector:			Cell or sector:		
		1	2	3	1	2	3	1	2	3	1	2	3
1x4   1x4	G9dh_2.4   G18dh_2.4	900	1800	—	No	No	—	2	2	—	0–2	0–2	—
	G9dht_2.4   G18dht_2.4	900	1800	—	M	M	—	2	2	—	0–2	0–2	—

M = Mandatory

A dash (—) indicates that the cell or sector is not used in this configuration.

There are two options for placing the equipment in the cabinet: GSM 900 on the left-hand side/GSM 1800 on the right-hand side, or the other way round. In each case the middle positions are not used.

### CDU-G Configurations for GSM 800 and GSM 1800

Table 20 Dual band configurations, CDU-G with hybrid in a fully- or partly-equipped cabinet

SCC	Configura- tion	Frequency Band			TMA			Number of Antennas			Allowed Number of dTRUs		
		Cell or sector:			Cell or sector:			Cell or sector:			Cell or sector:		
		1	2	3	1	2	3	1	2	3	1	2	3
1x8   1x4	G8dh_4.8   G18dh_2.4	800	1800	—	No	No	—	4	2	—	0–4	0–2	—
	G8dht_4.8   G18dht_2.4	800	1800	—	M	M	—	4	2	—	0–4	0–2	—
1x4   1x8	G8dh_2.4   G18dh_4.8	800	1800	—	No	No	—	2	4	—	0–2	0–4	—
	G8dht_2.4   G18dht_4.8	800	1800	—	M	No	—	2	4	—	0–2	0–4	—
2x4   1x4	2 x G8dh_2.4   G18dh_2.4	800	800	1800	No	No	No	2	2	2	0–2	0–2	0–2
	2 x G8dh_2.4   G18dh_2.4	800	800	1800	M	M	M	2	2	2	0–2	0–2	0–2
1x4   2x4	G8dh_2.4   2 x G18dh_2.4	800	1800	1800	No	No	No	2	2	2	0–2	0–2	0–2
	G8dht_2.4   2 x G18dht_2.4	800	1800	1800	M	M	M	2	2	2	0–2	0–2	0–2

M = Mandatory.

A dash (—) indicates that the cell or sector is not used in this configuration.

There are two options for placing the equipment in the cabinet: GSM 800 on the left-hand side/GSM 1800 on the right-hand side, or the other way round.

Table 21 Dual band configurations, CDU-G with hybrid in a partly-equipped cabinet only

SCC	Configura- tion	Frequency Band			TMA			Number of Antennas			Allowed Number of dTRUs		
		Cell or sector:			Cell or sector:			Cell or sector:			Cell or sector:		
		1	2	3	1	2	3	1	2	3	1	2	3
1x4   1x4	G8dh_2.4   G18dh_2.4	800	1800	—	No	No	—	2	2	—	0–2	0–2	—
	G8dht_2.4   G18dht_2.4	800	1800	—	M	M	—	2	2	—	0–2	0–2	—

M = Mandatory

A dash (—) indicates that the cell or sector is not used in this configuration.

There are two options for placing the equipment in the cabinet: GSM 800 on the left-hand side/GSM 1800 on the right-hand side, or the other way round. In each case the middle positions are not used.

### CDU-G Configurations for GSM 800 and GSM 1900

Table 22 Dual band configurations, CDU-G with hybrid in a fully- and partly-equipped cabinet

SCC	Configura- tion	Frequency Band			TMA			Number of Antennas			Allowed Number of dTRUs		
		Cell or Sector:			Cell or Sector:			Cell or Sector:			Cell or Sector:		
		1	2	3	1	2	3	1	2	3	1	2	3
1x8   1x4	G8dh_4.8   G19dh_2.4	800	1900	—	No	No	—	4	2	—	0-4	0-2	—
	G8dht_4.8   G19dht_2.4	800	1900	—	M	M	—	4	2	—	0-4	0-2	—
1x4   1x8	G8dh_2.4   G19dh_4.8	800	1900	—	No	No	—	2	4	—	0-2	0-4	—
	G8dht_2.4   G19dht_4.8	800	1900	—	M	M	—	2	4	—	0-2	0-4	—
2x4   1x4	2 x G8dh_2.4   G19dh_2.4	800	800	1900	No	No	No	2	2	2	0-2	0-2	0-2
	2 x G8dh_2.4   G19dh_2.4	800	800	1900	M	M	M	2	2	2	0-2	0-2	0-2
1x4   2x4	G8dh_2.4   2 x G19dh_2.4	800	1900	1900	No	No	No	2	2	2	0-2	0-2	0-2
	G8dht_2.4   2 x G19dht_2.4	800	1900	1900	M	M	M	2	2	2	0-2	0-2	0-2

M = Mandatory

A dash (—) indicates that the cell or sector is not used in this configuration.

There are two options for placing the equipment in the cabinet: GSM 800 on the left-hand side/GSM 1900 on the right-hand side, or the other way round.

Table 23 Dual band configurations, CDU-G with hybrid in a partly-equipped cabinet only

SCC	Configura- tion	Frequency Band			TMA			Number of Antennas			Allowed Number of dTRUs		
		Cell or sector:			Cell or Sector:			Cell or Sector:			Cell or Sector:		
		1	2	3	1	2	3	1	2	3	1	2	3
1x4   1x4	G8dh_2.4   G19dh_2.4	800	1900	—	No	No	—	2	2	—	0–2	0–2	—
	G8dht_2.4   G19dht_2.4	800	1900	—	M	M	—	2	2	—	0–2	0–2	—

M = Mandatory

A dash (—) indicates that the cell or sector is not used in this configuration.

There are two options for placing the equipment in the cabinet: GSM 800 on the left-hand side/GSM 1900 on the right-hand side, or the other way round. In each case the middle positions are not used.

### 6.3 SW Power Boost Configurations with CDU-G

This section does not include any additional site cell configurations. The section specifies which configurations support SW Power Boost (SPB).

A minimum of two TRXs is required in an antenna system to use SW Power Boost. Separate TX antennas must be used for the two transmitters in an SPB configuration.

#### SPB with CDU-G Configurations without Hybrid Combiner

SW Power Boost is supported in all of the SCCs with CDU-G, specified in *Section 6 on page 57*, which fulfill the following conditions:

- The configurations do not use hybrid combiner.
- The configurations have TRX connected to different antennas in the same antenna system.

#### SPB with CDU-G Configurations with Hybrid Combiner

SW Power Boost is supported in all of the SCCs with CDU-G, specified in *Section 6 on page 57*, which fulfill the following conditions:

- The configurations use hybrid combiner.

- The configurations have TRX connected to different antennas in the same antenna system.

One possible application using SPB together with hybrid combiner is creating overlaid and underlaid cells during cell planning, as described below:

- 1 One underlaid cell consists of the second TRX in the first dTRU and the first TRX in the second dTRU. SPB is used in this cell.
- 2 One overlaid cell consists of the two other TRXs. SPB is not used in this cell.

#### **6.4 Transmitter Coherent Combining (TCC) Configurations with CDU-G**

The section does not include any additional site cell configurations. The section specifies which configurations support Transmitter Coherent Combining (TCC).

A minimum of two TRXs is required in order to support TCC.

##### **TCC with CDU-G Configurations with Hybrid Combiner**

TCC is supported in all of the SCCs with CDU-G, specified in *Section 6 on page 57*, which fulfill the following conditions:

- The configurations use hybrid combiner.
- The configurations have two TRXs within the same dTRU.

## 7 Co-Siting with RBS 200 or RBS 2000 Macro Cabinets

This section shows expansions where RBSs, forming an original SCC, are co-sited and use TG-synchronization to form one new resulting SCC. Antennas are not shared.

### 7.1 RBS 200 Expanded with 12-TRX Cabinet

#### Co-Siting with RBS 200 Using a Filter Combiner



Table 24 Expansion using filter combiner

Re- sult SCC	Original Configuration					Expansion Configuration		
	Orig- inal SCC	Cabi- net	Combi- ner	Anten- nas	TMA	Orig- inal SCC	Basic Configu- ration	Antennas
1 x 16 *	1 x 4	RBS 200	FCOMB	(3)	No	1x12	F9d_2.12	(2)
		RBS 205	FCOMB	(3)	No		F18d_2.12	(2)
		RBS 205	FCOMB	(3)	M		F18dt_2.12	(2)
		RBS 205	FCOMB &DPX	(2)	No		F18d_2.12	(2)
		RBS 205	FCOMB	(2)	M		F18dt_2.12	(2)
1 x 20 **	1 x 8	RBS 200	FCOMB	(3)	No	1x12	F9d_2.12	(2)
		RBS 205	FCOMB	(3)	No		F18d_2.12	(2)
		RBS 205	FCOMB	(3)	M		F18dt_2.12	(2)
		RBS 205	FCOMB &DPX	(2)	No		F18d_2.12	(2)
		RBS 205	FCOMB	(2)	M		F18dt_2.12	(2)
3 x 8 ***	3 x 4  ****	RBS 200	FCOMB	(3) (3) (3)	No	3x4	3 x F9d_2.4	(2) (2) (2)
		RBS 205	FCOMB	(3) (3) (3)	No		3 x F18d_2.4	(2) (2) (2)
		RBS 205	FCOMB	(3) (3) (3)	M		3 x F18dt_2.4	(2) (2) (2)
		RBS 205	FCOMB &DPX	(2) (2) (2)	No		3 x F18d_2.4	(2) (2) (2)
		RBS 205	FCOMB	(2) (2) (2)	M		3 x F18dt_2.4	(2) (2) (2)

M = Mandatory

\* 1 x 6, 1 x 8, 1 x 10, 1 x 12 and 1 x 14 can be accomplished with a partly-equipped expansion configuration.

\*\* 1 x 10, 1 x 12, 1 x 14, 1 x 16 and 1 x 18 can be accomplished with a partly-equipped expansion configuration.

\*\*\* 3 x 6 can be accomplished with a partly-equipped expansion configuration.

\*\*\*\* When using TG-synchronization, only one RBS 200/RBS 205 can act as master. Therefore the 3 x 4 configuration, which contains three separate RBSs, must be rebuilt to one single RBS; that is, all three sectors of the RBS 200 must be connected to the same TMCB.

### Co-Siting with RBS 200 Using Hybrid Combiner

Table 25 Expansion using hybrid combiner

Re- sult SCC	Original Configuration					Expansion Configuration		
	Orig- inal SCC	Cabi- net	Combi- ner	Anten- nas	TMA	Orig- inal SCC	Basic Con- figuration	Antennas
3 x 8 *	3 x 4 **	RBS 200	HCOMB	(3) (3) (3)	No	3 x 4	3 x G9dh_2.4	(2) (2) (2)
		RBS 205	HCOMB	(3) (3) (3)	No		3 x G18dh_2.4	(2) (2) (2)
		RBS 205	HCOMB	(3) (3) (3)	M		3 x G18dht_2.4	(2) (2) (2)
		RBS 205	HCOMB &DPX	(2) (2) (2)	No		3 x G18dh_2.4	(2) (2) (2)
		RBS 205	HCOMB	(2) (2) (2)	M		3 x G18dht_2.4	(2) (2) (2)

M = Mandatory

\* 3 x 6 can be accomplished with a partly-equipped expansion configuration.  
1 x 8 can be accomplished with one RBS 200/RBS 205 and a partly-equipped expansion configuration.

\*\* When using TG-synchronization, only one RBS 200/RBS 205 can act as master. Therefore the 3 x 4 configuration, which contains three separate RBSs, must be rebuilt to one single RBS; that is, all three sectors of the RBS 200 must be connected to the same TMCB.

## 7.2 6-TRX RBS 2000 Macro Cabinets Expanded with 12-TRX Cabinet

### Co-Siting with Single TRU-Based RBS 2000 Using Filter Combiner

Table 26 Expansion using filter combiner

Result SCC	RBS 1			RBS 2		
	Original SCC	Basic Configuration	Antennas	Original SCC	Basic Configuration	Antennas
1 x 18 *	1 x 6	D9d_2.6	(2)	1 x 12	F9de_2.12	(2)
		D18d_2.6	(2)		F18d_2.12	(2)
		D18_2.6	(2)		F18dt_2.12	(2)
1 x 24 **	1 x 12	D9d_2.12	(2)	1 x 12	F9de_2.12	(2)
		D18d_2.12	(2)		F18d_2.12	(2)
		D18_2.12	(2)		F18dt_2.12	(2)

\* 1 x 8, 1 x 10, 1 x 12, 1 x 14 and 1 x 16 can be accomplished with a partly-equipped RBS 2.

\*\* 1 x 14, 1 x 16, 1 x 18, 1 x 20 and 1 x 22 can be accomplished with a partly-equipped RBS 2.

### Co-Siting with Single TRU-Based RBS 2000 Using Hybrid Combiner

Table 27 Expansion using hybrid combiner

Re- sult SCC	RBS 1			RBS 2		
	Orig- inal SCC	Basic Configuration	Anten- nas	Orig- inal SCC	Basic Configuration	Anten- nas
3 x 8 *	3 x 4	3 x C+ 9d_2.4	(2) (2) (2)	3 x 4	3 x G9dh_2.4	(2) (2) (2)
		3 x C+ 9d_2.4	(2) (2) (2)		3 x G9dht_2.4	(2) (2) (2)
		3 x C+ 18d_2.4	(2) (2) (2)		3 x G18dh_2.4	(2) (2) (2)
		3 x C+ 18_2.4	(2) (2) (2)		3 x G18dht_2.4	(2) (2) (2)
		3 x C+ 19d_2.4	(2) (2) (2)		3 x G19dh_2.4	(2) (2) (2)
		3 x C+ 19_2.4	(2) (2) (2)		3 x G19dht_2.4	(2) (2) (2)

\* 3 x 6 is accomplished with a partly-equipped RBS 2.

### 7.3 12-TRX RBS 2000 Macro Cabinet Expanded with 12-TRX Cabinet

#### Co-Siting with dTRU-Based RBS 2000 Macro Cabinet Using Filter Combiner

Table 28 Expansion using filter combiner

Result SCC	RBS 1			RBS 2		
	Original SCC	Basic Configuration	Antennas	Original SCC	Basic Configuration	Antennas
3 x 8 *	8 + 4	F9d_2.8 + F9d_2.4	(2) (2) (-)	4 + 8	F9d_2.4 + F9d_2.8	(-) (2) (2)
		F9dt_2.4 + F9dt_2.4	(2) (2) (-)		F9dt_2.4 + F9dt_2.8	(-) (2) (2)
		F18d_2.8 + F18d_2.4	(2) (2) (-)		F18d_2.4 + F18d_2.8	(-) (2) (2)
		F18dt_2.8 + F18dt_2.4	(2) (2) (-)		F18dt_2.4 + F18dt_2.8	(-) (2) (2)
1 x 24 **	1 x 12	F9d_2.12	(2)	1 x 12	F9d_2.12	(2)
		F9dt_2.12	(2)		F9dt_2.12	(2)
		F18d_2.12	(2)		F18d_2.12	(2)
		F18dt_2.12	(2)		F18dt_2.12	(2)

\* 3 x 6 can be accomplished with a partly-equipped RBS 1 and RBS 2, although it is more easily performed with 2 x 6 in RBS 1 and 1 x 8 with three dTRUs in RBS 2. TG-synchronization is not required.

\*\* 1 x 14, 1 x 16, 1 x 18, 1 x 20 and 1 x 22 are accomplished with a partly-equipped RBS 2.

### Co-Siting with dTRU-Based RBS 2000 Using Hybrid Combiner

Table 29 Expansion using hybrid combiner

Result SCC	RBS 1			RBS 2		
	Original SCC	Basic Configuration	Antennas	Original SCC	Basic Configuration	Antennas
3 x 8 *	3 x 4	3 x G9dh_2.4 3 x G9dht_2.4 3 x G18dh_2.4 3 x G18dht_2.4 3 x G19dh_2.4 3 x G19dht_2.4	(2) (2) (2) (2) (2) (2) (2) (2) (2) (2) (2) (2) (2) (2) (2) (2) (2) (2)	3 x 4	3 x G9dh_2.4 3 x G9dht_2.4 3 x G18dh_2.4 3 x G18dht_2.4 3 x G19dh_2.4 3 x G19dht_2.4	(2) (2) (2) (2) (2) (2) (2) (2) (2) (2) (2) (2) (2) (2) (2) (2) (2) (2)

\* 3 x 6 is accomplished with a partly-equipped RBS 2.

### Co-Siting with dTRU-Based RBS 2000 without Hybrid Combiner

Table 30 Expansion using CDU-G without hybrid combiner

Result SCC	RBS 1			RBS 2		
	Original SCC	Basic Configuration	Antennas	Original SCC	Basic Configuration	Antennas
3 x 4	3 x 2	3 x G9d_2.2 3 x G9dt_2.2 3 x G18d_2.2 3 x G18dt_2.2 3 x G19dh_2.4 3 x G19dht_2.4	(2) (2) (2) (2) (2) (2) (2) (2) (2) (2) (2) (2) (2) (2) (2) (2) (2) (2)	3 x 2	3 x G9d_2.4 3 x G9dt_2.4 3 x G18d_2.4 3 x G18dt_2.4 3 x G19dh_2.4 3 x G19dht_2.4	(2) (2) (2) (2) (2) (2) (2) (2) (2) (2) (2) (2) (2) (2) (2) (2) (2) (2)

## 8 Co-Siting with TDMA RBS Using an ASU

The ASU is used for co-siting with a TDMA RBS, more specifically RBS 884 for 800 MHz and 1900 MHz, and RBS 882 for 800 MHz only. The unit allows a TDMA cabinet to share receiver antennas with a GSM cabinet. The ASU is installed in a dTRU based GSM cabinet.

The implementation is for 800 and 1900 MHz. The end configuration differs for different site configurations of the TDMA RBS. One-, two- and three-sector sites can be supported. In the case of two- or three-sector sites, the figures below only show one part of the RBS.

### 8.1 Separate TX and Two Separate RX Antennas

The original antenna configuration of the TDMA RBS is TX + RX + RX. When co-siting is configured, the antennas are moved from the TDMA RBS to the dTRU based RBS. The dTRU based RBS can be prepared for co-siting already at the factory. The RX paths to the TDMA RBS will go through the ASU.

By moving the receiver antennas to the dTRU based RBS, it is possible to benefit from minimum interference with the old equipment.

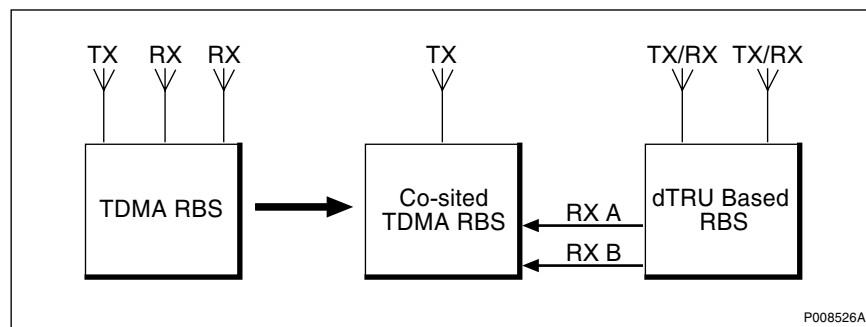

Figure 30 Separate TX and two separate RX antennas, no TMAs

If TMAs are used in the original configuration, they are replaced with dual-duplex TMAs (ddTMAs).

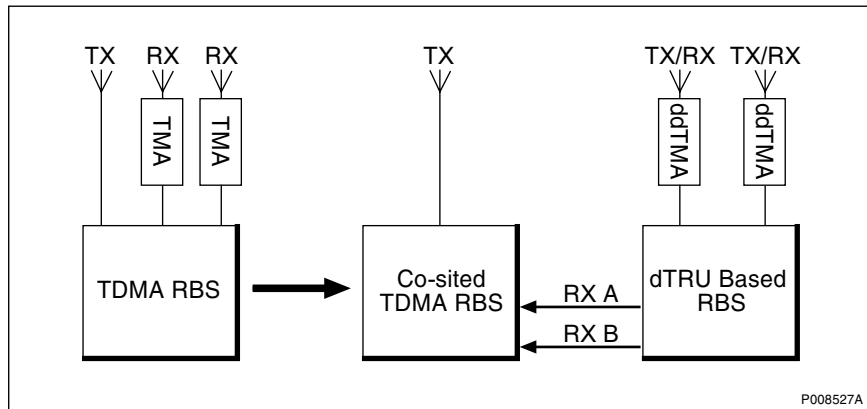

Figure 31 Separate TX and two separate RX antennas, with TMAs

No new antennas are required.

### 8.2 One Duplex Antenna RX/TX

The TDMA RBS may be equipped with only one TX/RX antenna. The recommendation in this case is to add two antennas for the dTRU based RBS. One RX signal from the dTRU based RBS is supplied to the TDMA RBS, thus adding RX diversity to the TDMA RBS.

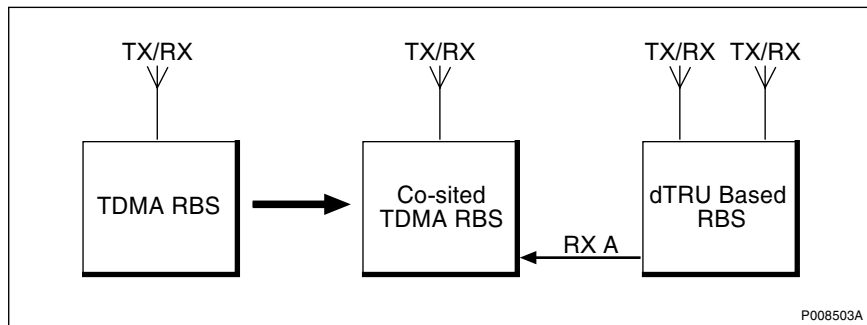

Figure 32 One duplex antenna RX/TX

### 8.3 Two Separate Duplex Antennas

If two separate duplex antennas are already in use, the recommendation is to install new antennas for the dTRU based RBS and not use co-siting at all.



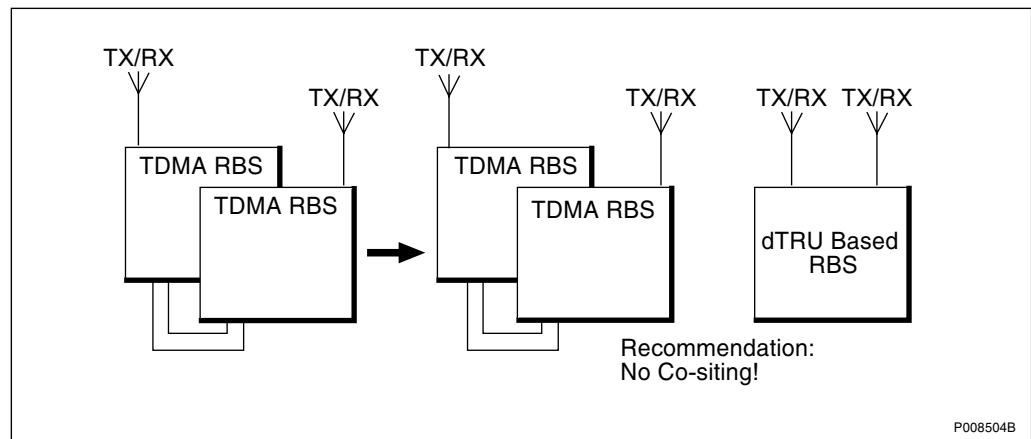

Figure 33 Two separate duplex antennas

## 8.4 One RX and One Duplex Antenna

If the original antenna arrangement is TX/RX + RX, the recommendation differs for configurations where the duplex filter is mounted internally, without the possibility to access the TX and RX ports separately, and configurations where the RX path is accessible.

### Internal Duplex Filter

If the duplex filter is internal and the RX path is not accessible, the recommendation is to add one antenna and rebuild the configuration in the same way as in the case with TX + RX + RX in *Section 8.1 on page 85*.

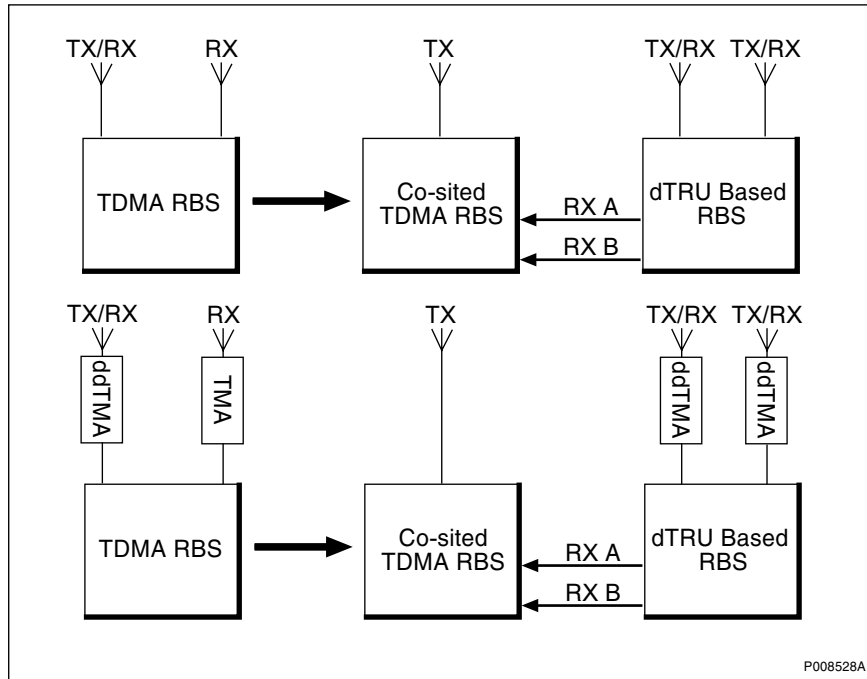

Figure 34 Internal duplex filter

A special case is where only one TX/RX and one RX port are accessible from the outside of the cabinet. In that case the solution stated below can be used. Note that the three duplex filters in series (one internal and two external) will degrade the TX performance of the co-sited RBS.

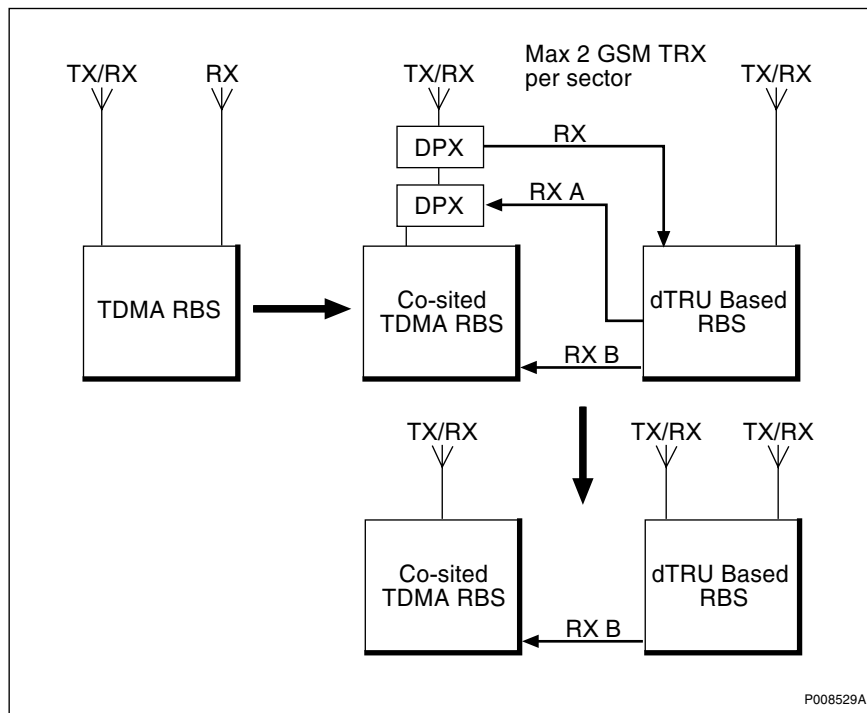

Figure 35 Internal duplex filter and only two antenna ports accessible

### External Duplex Filter

If an external duplex filter is used, it is possible to expand the configuration in two steps. The first step does not require any new antennas, but limits the number of GSM TRXs to two (that is, one dTRU) for each sector. Support of more GSM TRXs requires additional antennas.

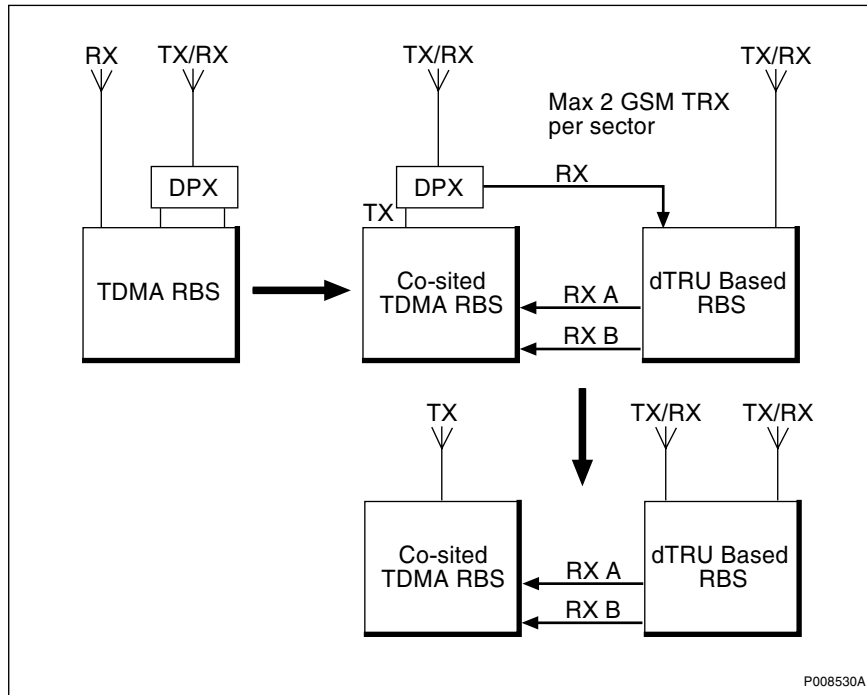

Figure 36 External duplex filter

# RBS 2106

## Antenna Configurations

### Description

This document describes the antenna configurations that are possible for the RBS 2106.

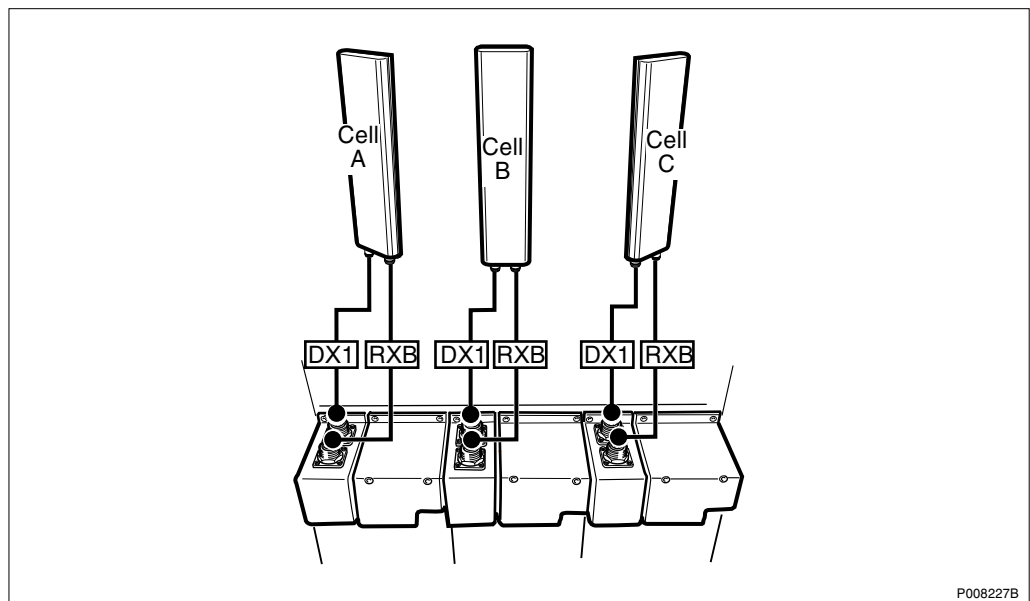

# Contents

<b>1</b>	<b>Introduction</b>	<b>3</b>
<b>2</b>	<b>Antenna Connection Field</b>	<b>4</b>
<b>3</b>	<b>CDU-F Antenna Connections</b>	<b>7</b>
<b>4</b>	<b>CDU-F Configurations</b>	<b>8</b>
4.1	3x2 CDU-F and 3x4 CDU-F	8
4.2	1x8 CDU-F	10
4.3	1x12 CDU-F	11
4.4	2x6 CDU-F	13
4.5	1x4 + 1x8 CDU-F	14
4.6	1x8 + 1x4 CDU-F	16
<b>5</b>	<b>CDU-G Antenna Connections</b>	<b>18</b>
<b>6</b>	<b>CDU-G Configurations</b>	<b>19</b>
6.1	3x2 CDU-G and 3x4 CDU-G	19
6.2	1+1+2 CDU-G	21
6.3	1x4 CDU-G without hybrid combiner and 1x8 CDU-G with hybrid combiner	22
6.4	1x6 CDU-G without hybrid combiner and 1x12 CDU-G with hybrid combiner	24
6.5	2x6 CDU-G	25

# 1 Introduction

The various configurations available for cabinets are described according to the following example:

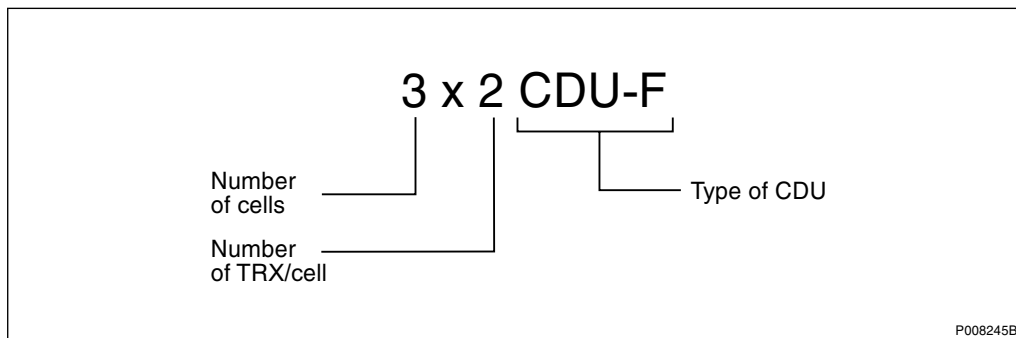

*Figure 1 CDU configuration key*

In the example above, the cabinet is configured for three cells, each using two TRXs. The total number TRXs is thus six in this case. The CDU is type CDU-F.

**Note:** If TMA is used the bias injectors must be installed.

## 2 Antenna Connection Field

Each CDU uses a set of standard RF wiring patterns for connection between each CDU and the antenna connection field.

The figures below provide an overview of the antenna sharing connectors and cabling from the ASU and CDU.



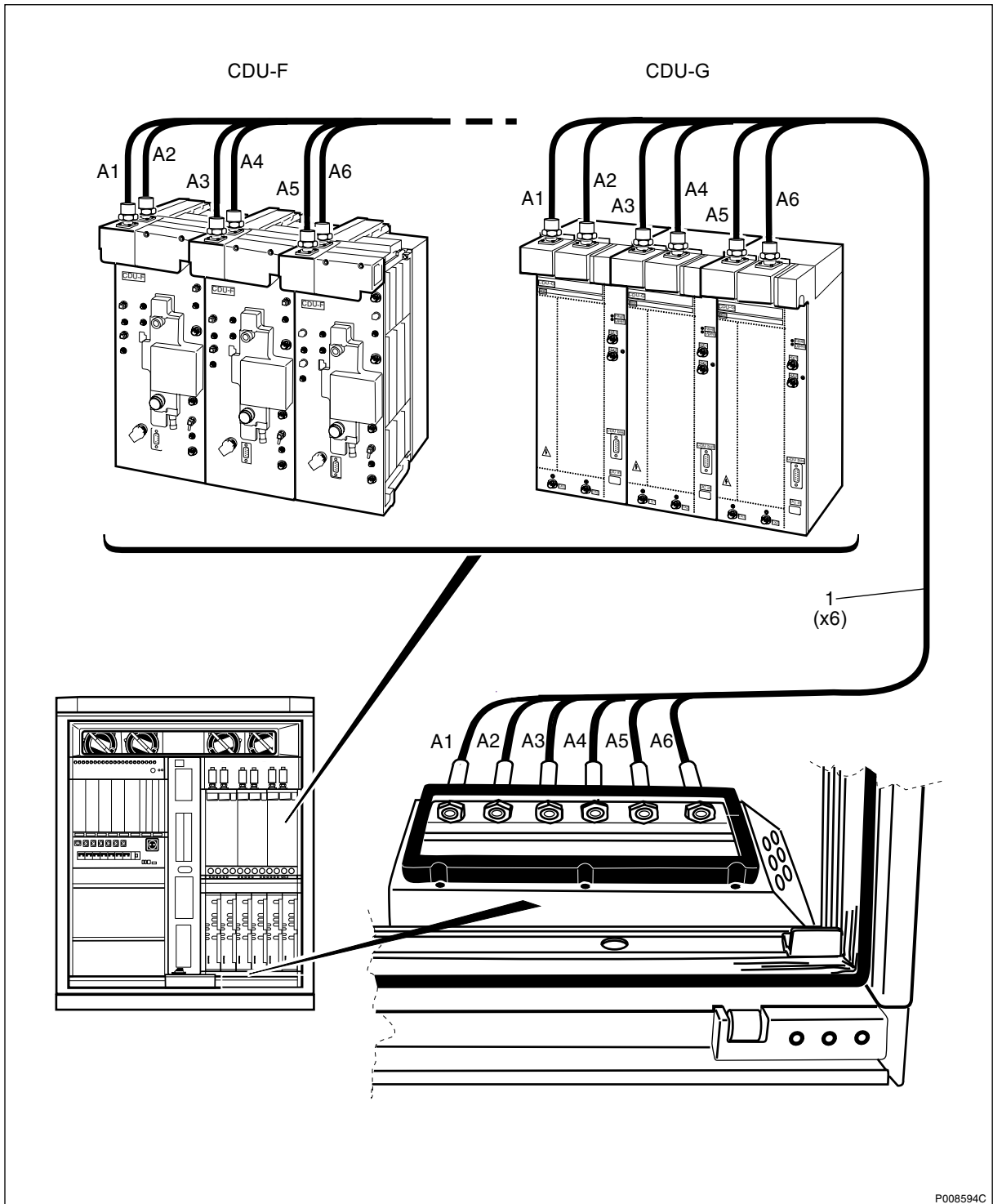

Figure 2 Internal cabling between CDUs and antenna connection field

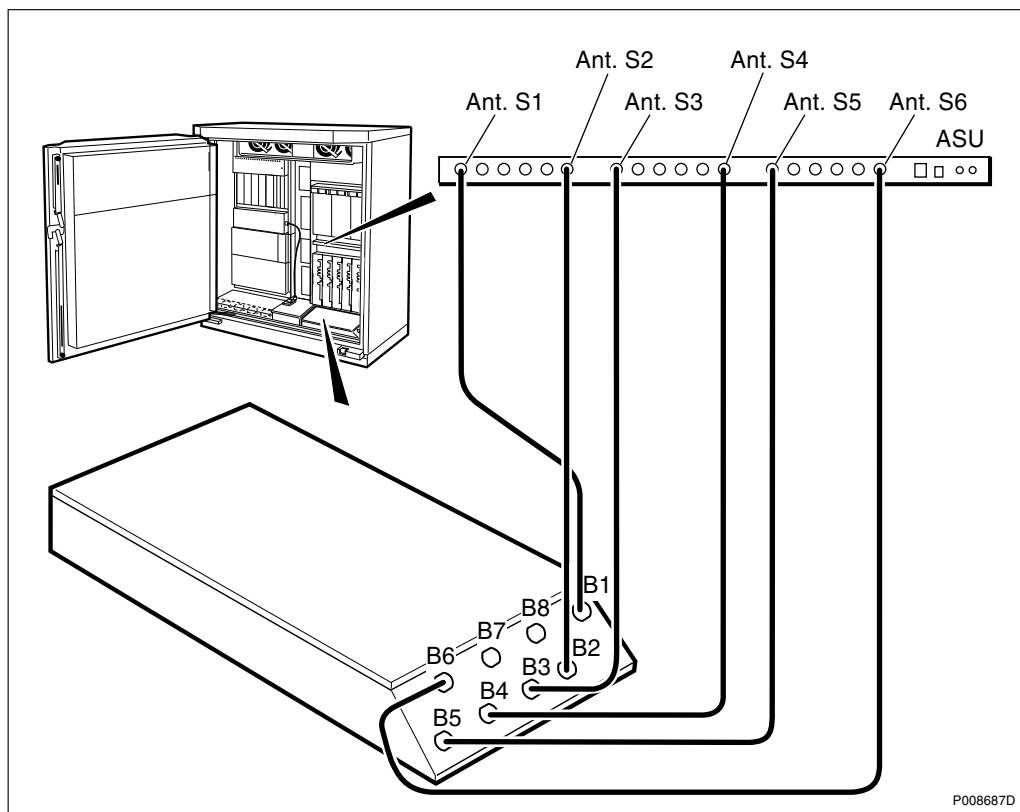

Figure 3 Cabling between ASU and antenna sharing connectors

### 3 CDU-F Antenna Connections

The antenna connectors are located on the top of the CDU, see *figures below*.

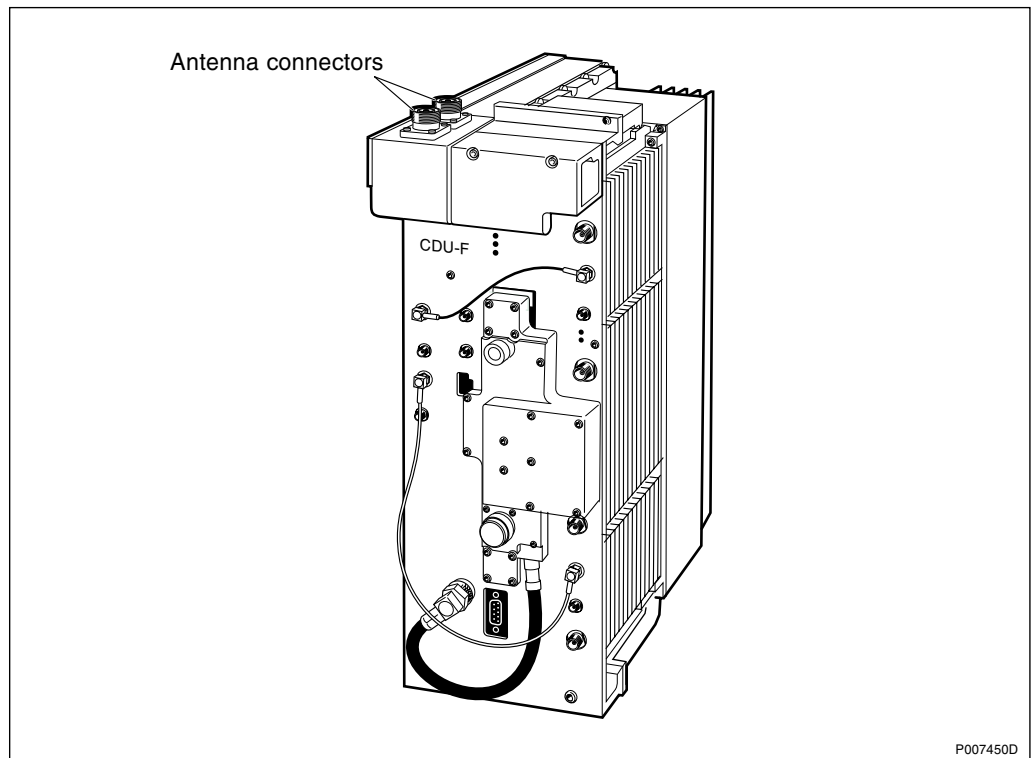

Figure 4 CDU-F layout

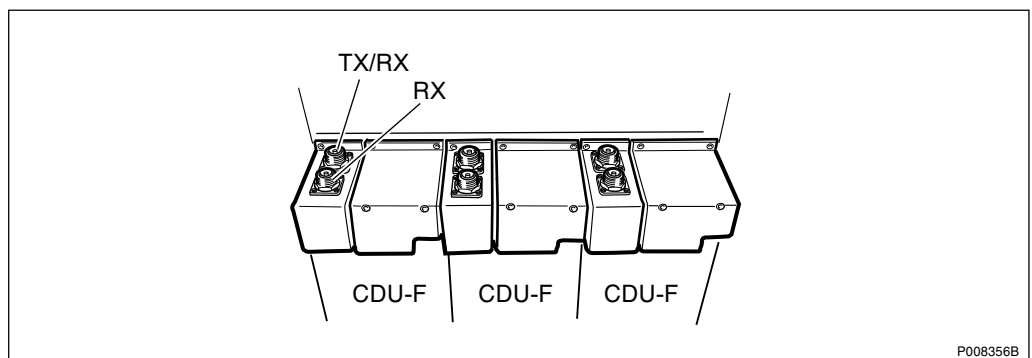

Figure 5 CDU-F antenna feeder connectors

## 4 CDU-F Configurations

**Note:** In the figures and tables that follow, only cabinets that are fully-equipped are shown. Configurations consisting of part of the fully-equipped cabinet are also possible to extract from the following figures and tables.

See *Figure 2 on page 5*, *Figure 3 on page 6* and *Figure 5 on page 7* for a description of the column headers in the tables below.

### 4.1 3x2 CDU-F and 3x4 CDU-F

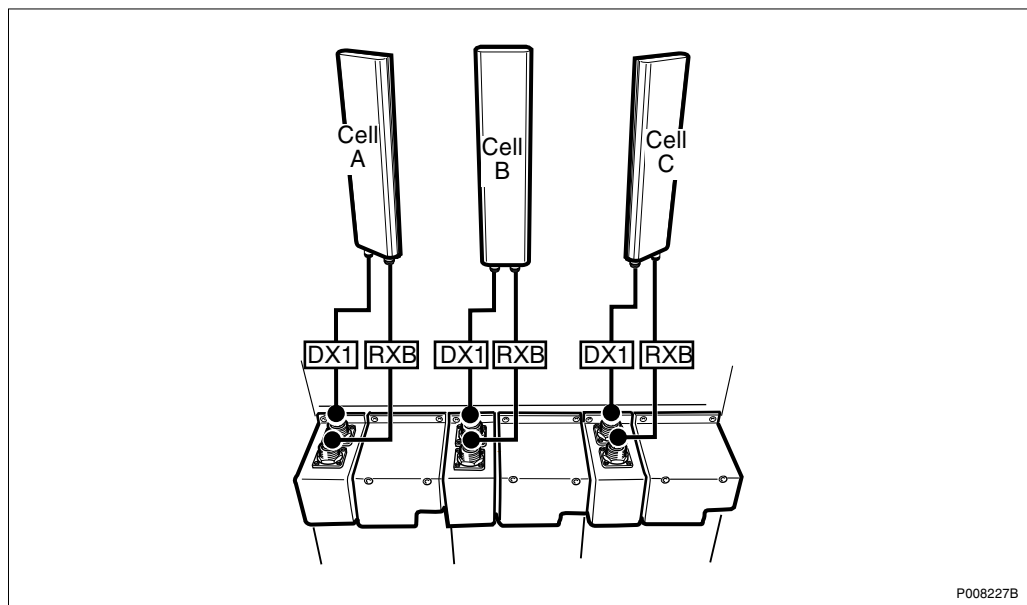

Figure 6 Configuration without TMA

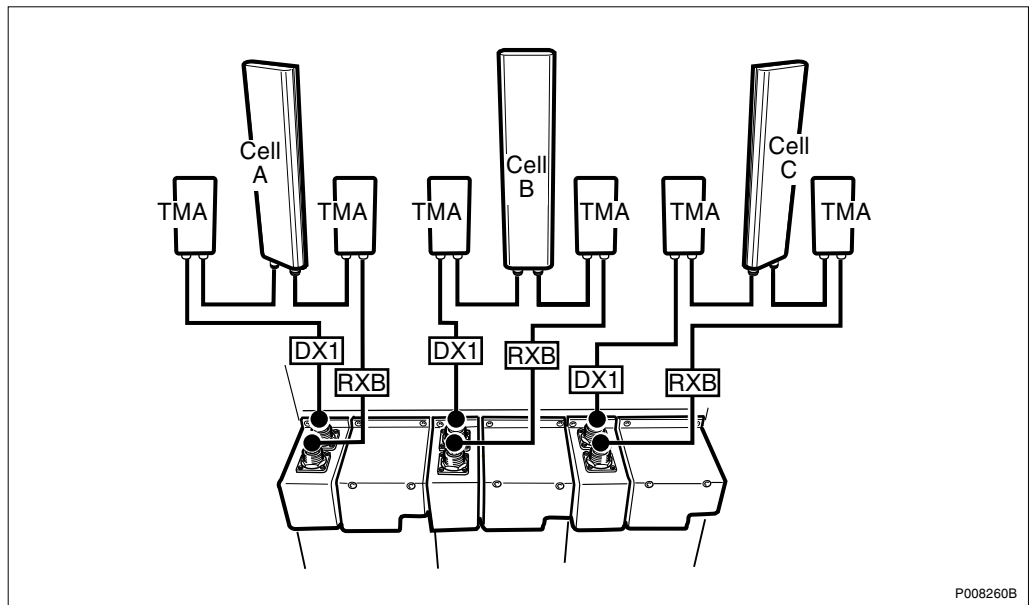

Figure 7 Configuration with TMA

Table 1 3x2 CDU-F and 3x4 CDU-F

Cell	CDU					ASU Connector
	CDU No.	Feeder label	Connector		Signal	
			CDU	Conn. field		
A	1	CellA: DX1	TX/RX	A1	TX/RX A	S1
		CellA: RXB	RX	A2	RX B	S2
B	2	CellB: DX1	TX/RX	A3	TX/RX A	S3
		CellB: RXB	RX	A4	RX B	S4
C	3	CellC: DX1	TX/RX	A5	TX/RX A	S5
		CellC: RXB	RX	A6	RX B	S6

From the configuration shown in the figures and table above, the following configurations can be derived:

- 1x2 CDU-F
- 2x2 CDU-F
- 1x4 CDU-F
- 2x4 CDU-F

4.2

1x8 CDU-F

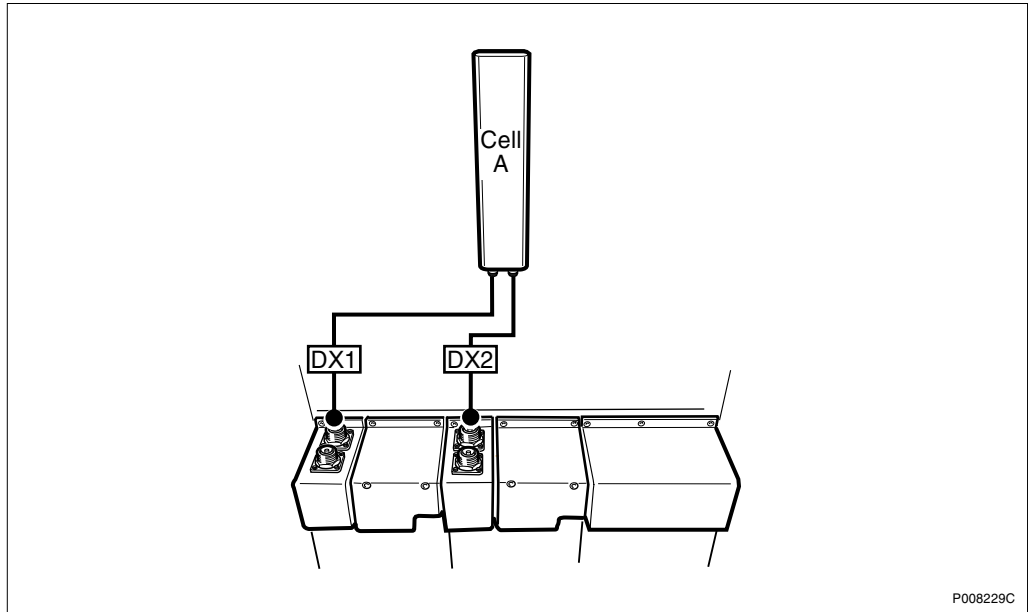

P008229C

Figure 8 Configuration without TMA

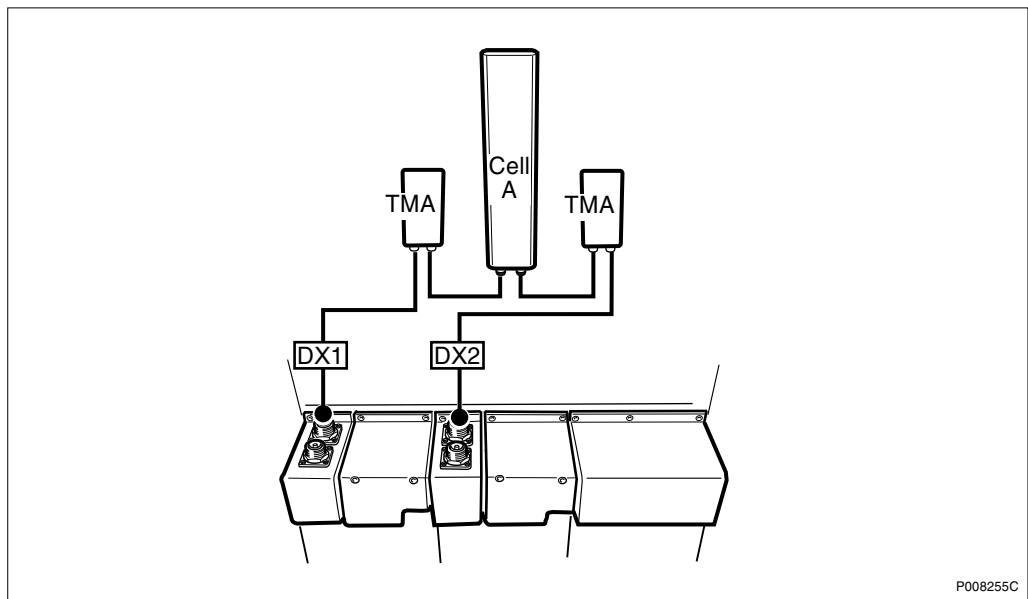

P008255C

Figure 9 Configuration with TMA

Table 2 1x8 CDU-F

Cell	CDU					ASU Connector
	CDU No.	Feeder label	Connector		Signal	
			CDU	Conn. field		
A	1	CellA: DX1	TX/RX	A1	TX/RX A	S1
	2	CellA: DX2	TX/RX	A3	TX/RX B	S3

4.3

1x12 CDU-F

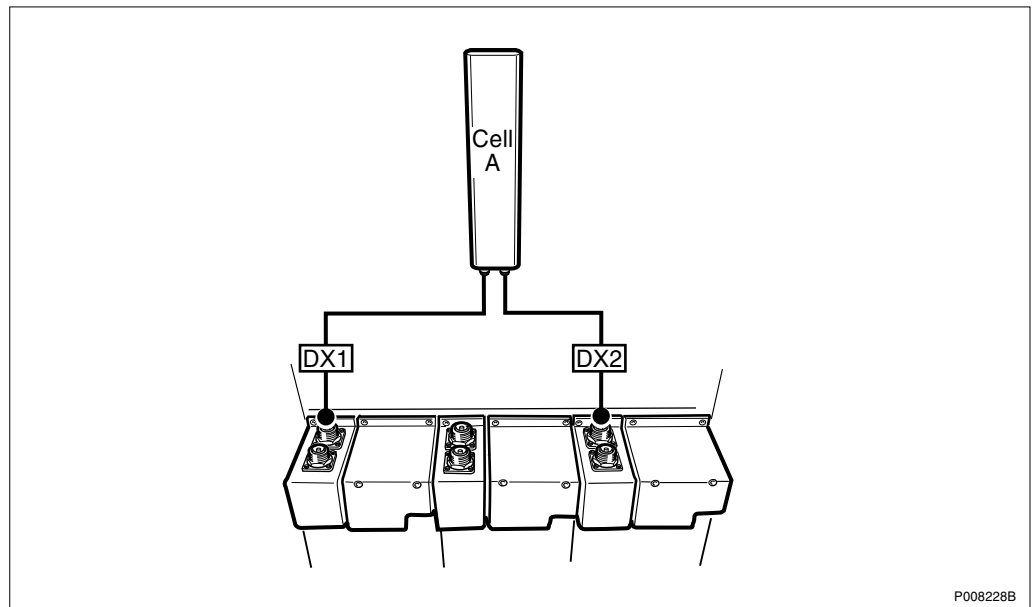

Figure 10 Configuration without TMA

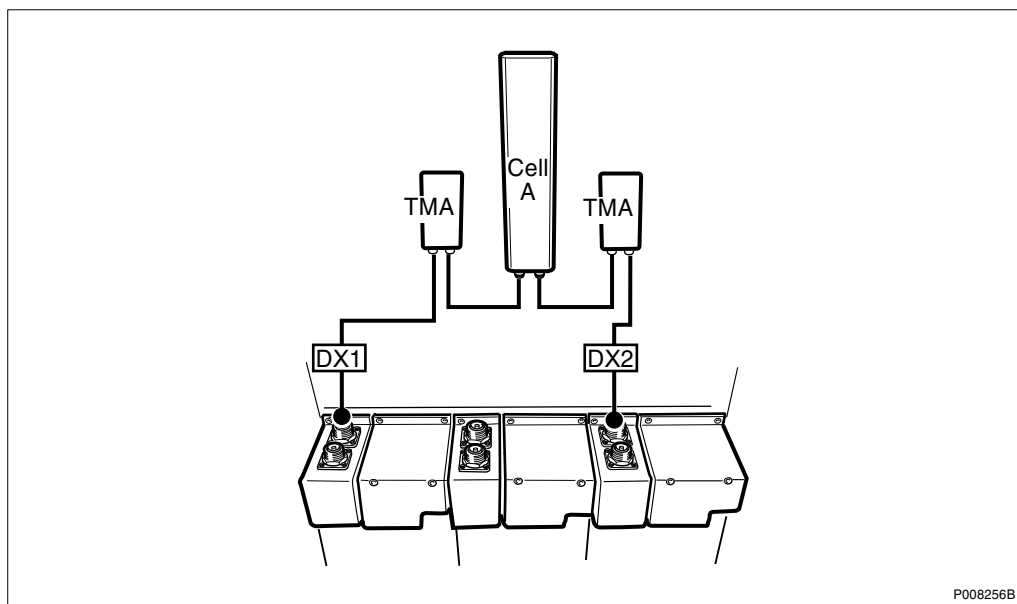

Figure 11 Configuration with TMA

Table 3 1x12 CDU-F

Cell	CDU					ASU Connector
	CDU No.	Feeder label	Connector		Signal	
			CDU	Conn. field		
A	1	CellA: DX1	TX/RX	A1	TX/RX A	S1
	3	CellA: DX2	TX/RX	A5	TX/RX B	S5



**4.4 2x6 CDU-F**

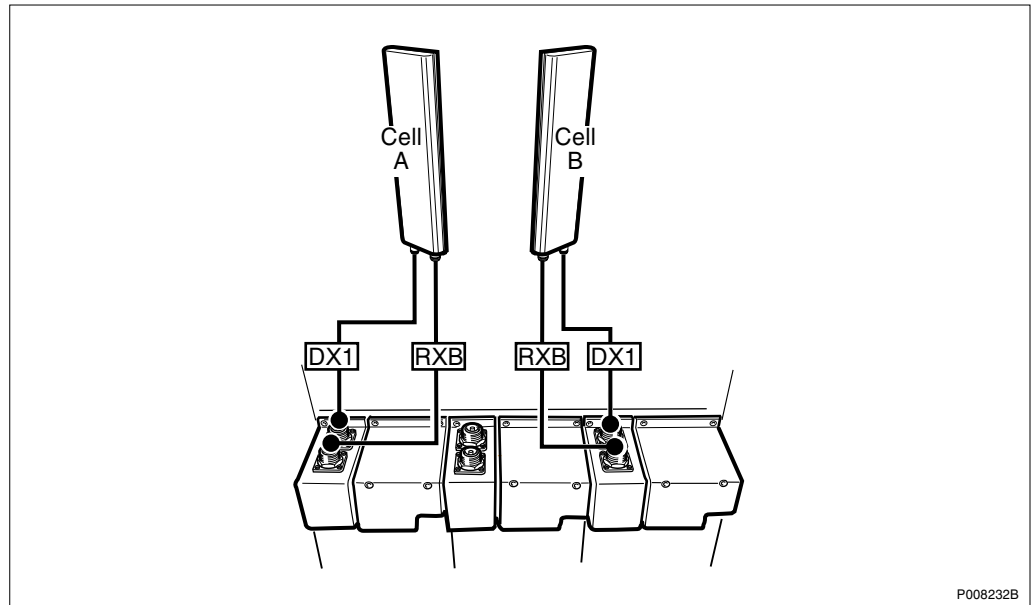

Figure 12 Configuration without TMA

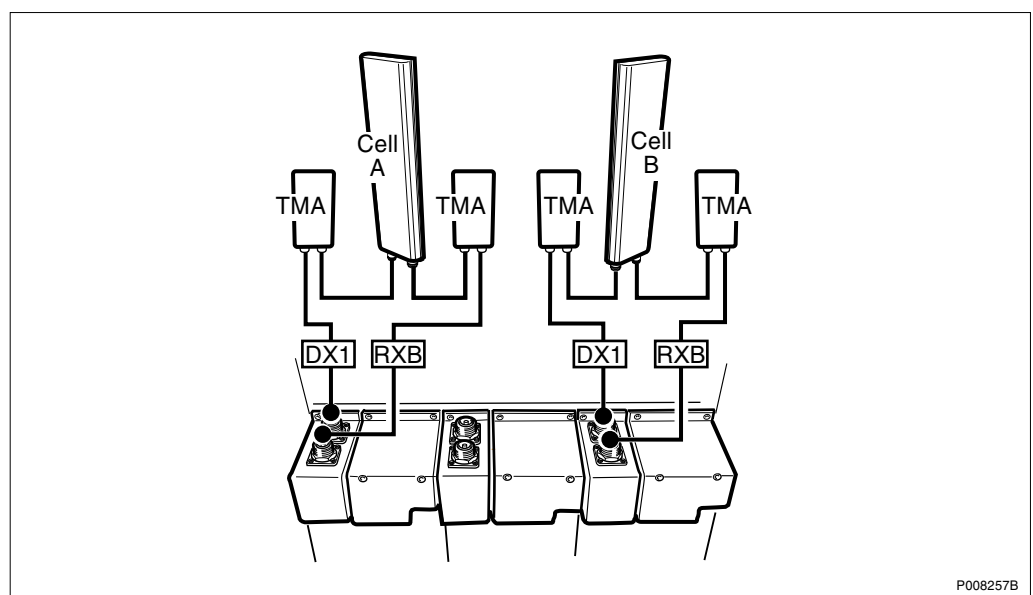

Figure 13 Configuration with TMA

Table 4 2x6 CDU-F

Cell	CDU					ASU Connector
	CDU No.	Feeder label	Connector		Signal	
			CDU	Conn. field		
A	1	CellA: DX1	TX/RX	A1	TX/RX A	S1
		CellA: RXB	RX	A2	RX B	S2
B	3	CellB: DX1	TX/RX	A5	TX/RX A	S5
		CellB: RXB	RX	A6	RX B	S6

4.5

1x4 + 1x8 CDU-F

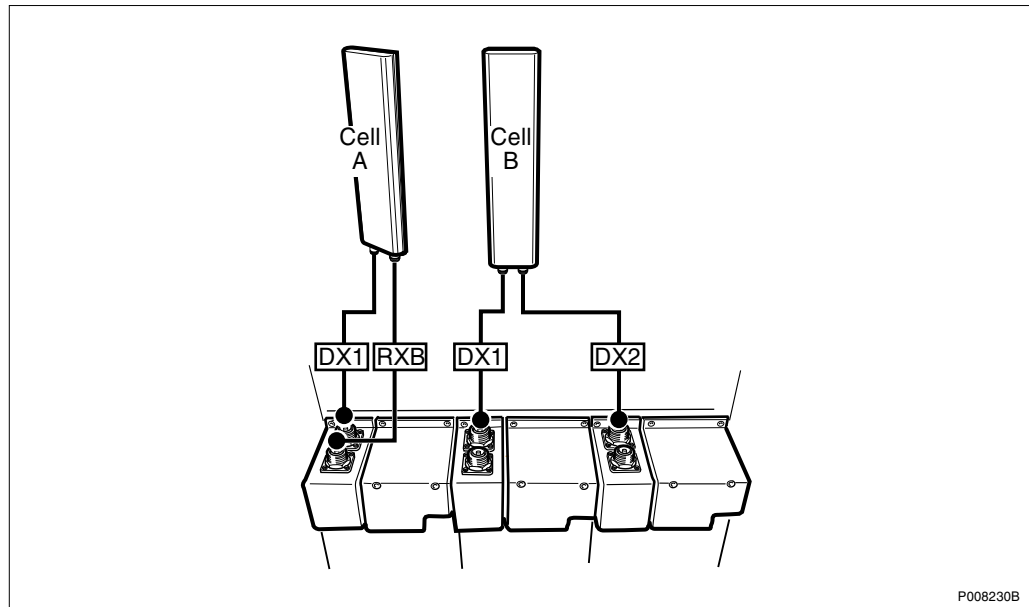

Figure 14 Configuration without TMA

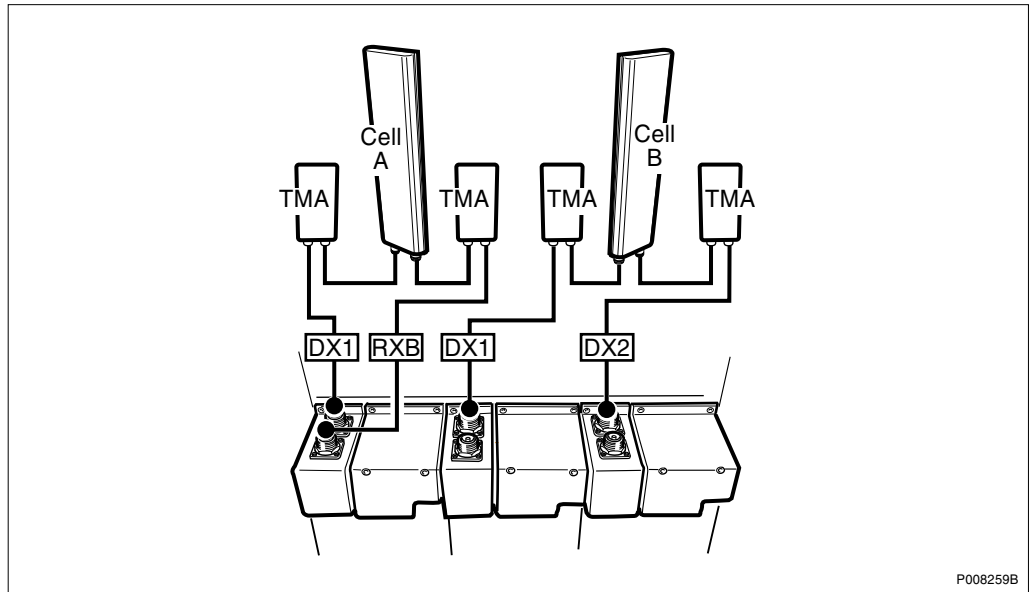

Figure 15 Configuration with TMA

Table 5 1x4+1x8 CDU-F

Cell	CDU					ASU Connector
	CDU No.	Feeder label	Connector		Signal	
			CDU	Conn. field		
A	1	CellA: DX1	TX/RX	A1	TX/RX A	S1
		CellA: RXB	RX	A2	RX B	S2
B	2	CellB: DX1	TX/RX	A3	TX/RX B	S3
	3	CellB: DX2	TX/RX	A5	TX/RX B	S5

4.6 1x8 + 1x4 CDU-F

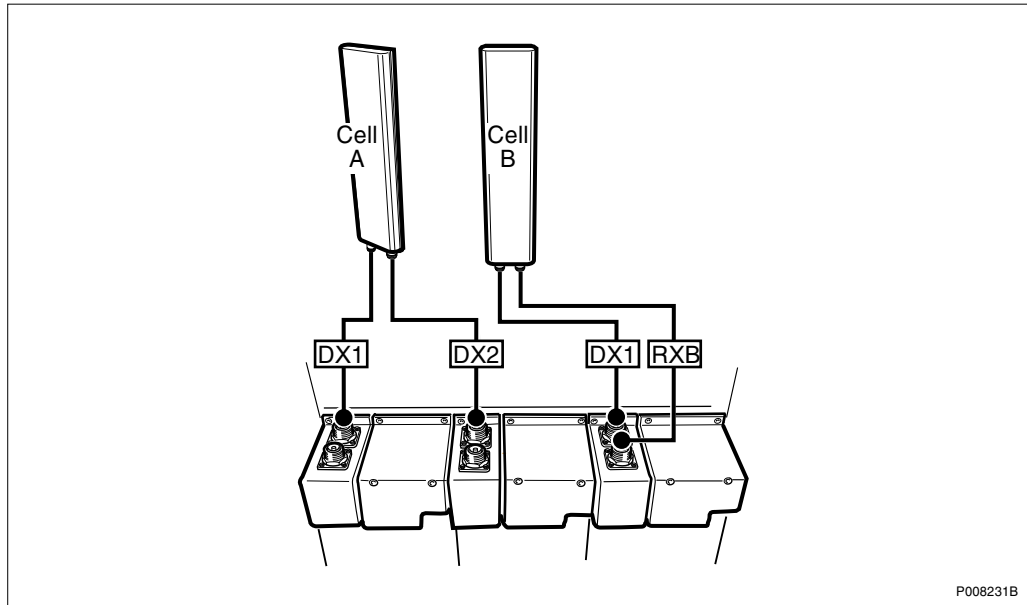

Figure 16 Configuration without TMA

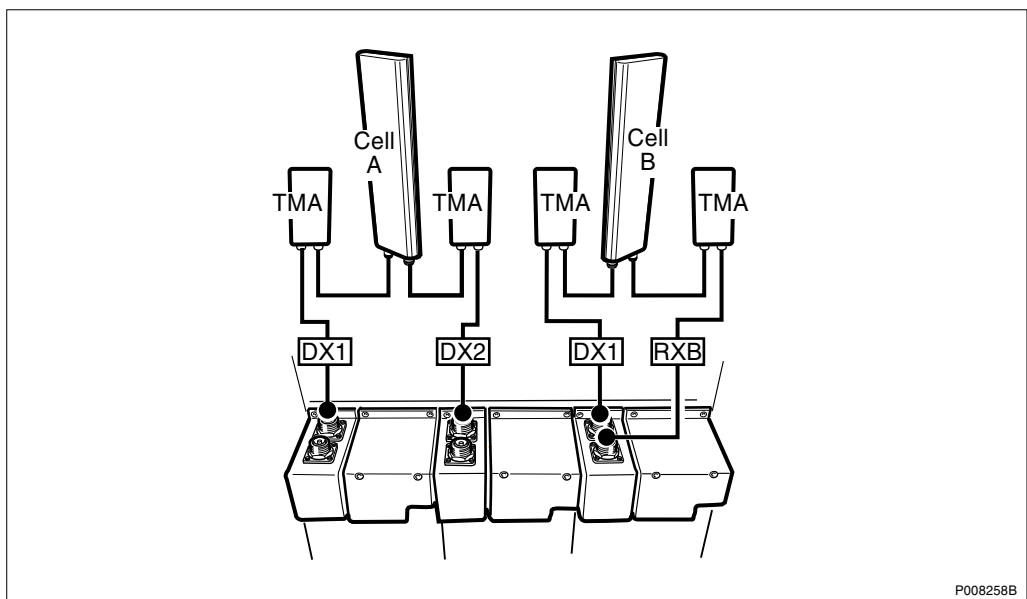

Figure 17 Configuration with TMA

Table 6 1x8+1x4 CDU-F

Cell	CDU					ASU Connector
	CDU No.	Feeder label	Connector		Signal	
			CDU	Conn. field		
A	1	CellA: DX1	TX/RX	A1	TX/RX A	S1
	2	CellA: DX2	TX/RX	A3	TX/RX B	S3
B	3	CellB: DX1	TX/RX	A5	TX/RX A	S5
		CellB: RXB	RX	A6	RX B	S6

## 5 CDU-G Antenna Connections

The antenna connectors are located on the top of the CDU, see *figures below*.

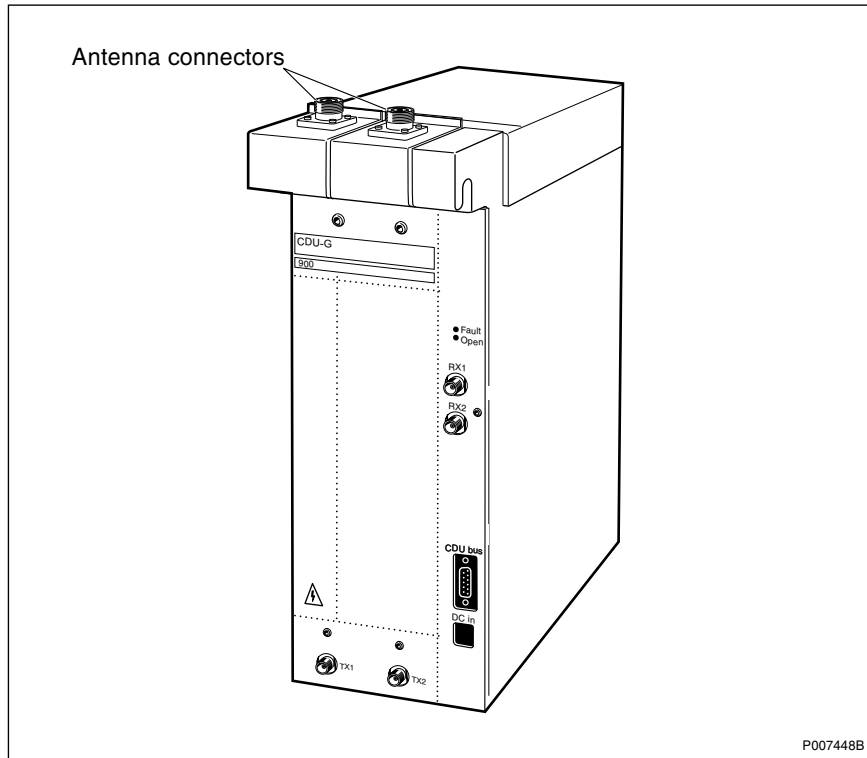

Figure 18 CDU-G layout

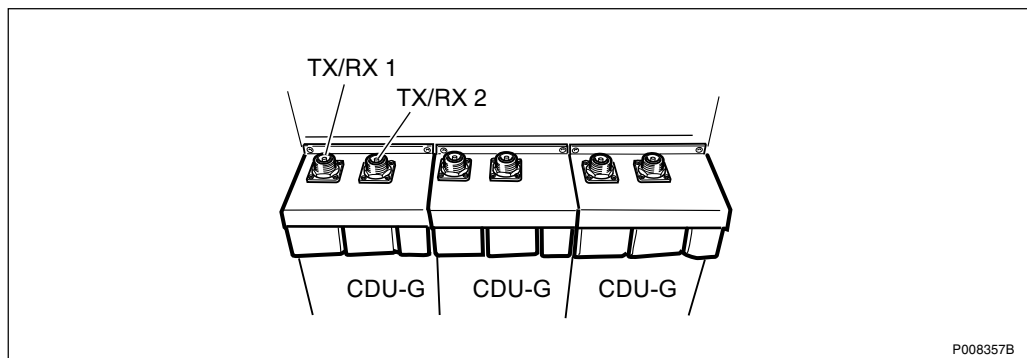

Figure 19 CDU-G antenna feeder connectors

## 6 CDU-G Configurations

**Note:** In the figures and tables that follow, only cabinets that are fully-equipped are shown. Configurations consisting of part of the fully-equipped cabinet are also possible to extract from the following figures and tables.

See *Figure 2 on page 5*, *Figure 3 on page 6* and *Figure 19 on page 18* for a description of the column headers in the tables below.

### 6.1 3x2 CDU-G and 3x4 CDU-G

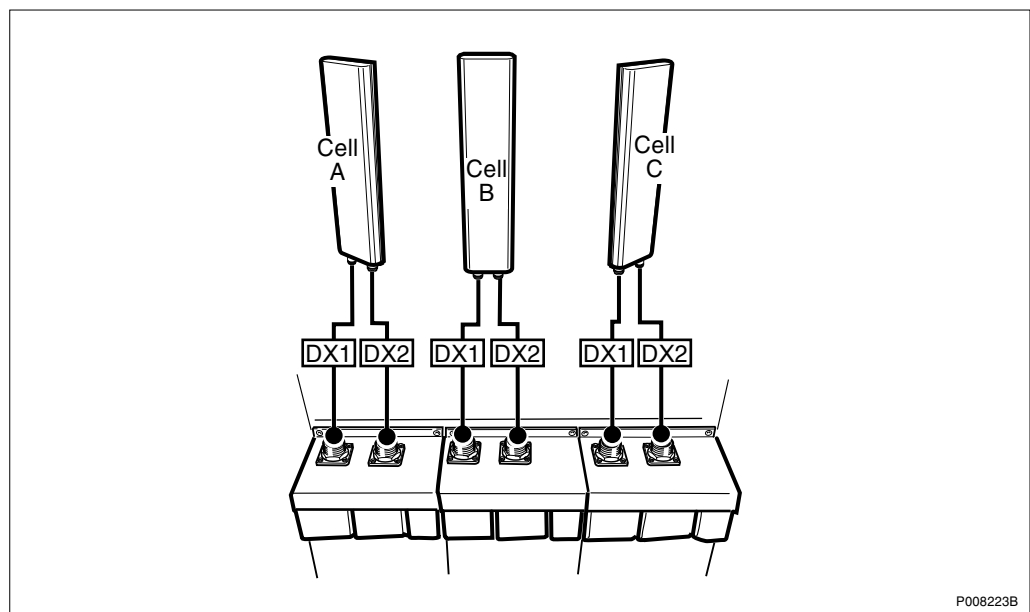

Figure 20 Configuration without TMA

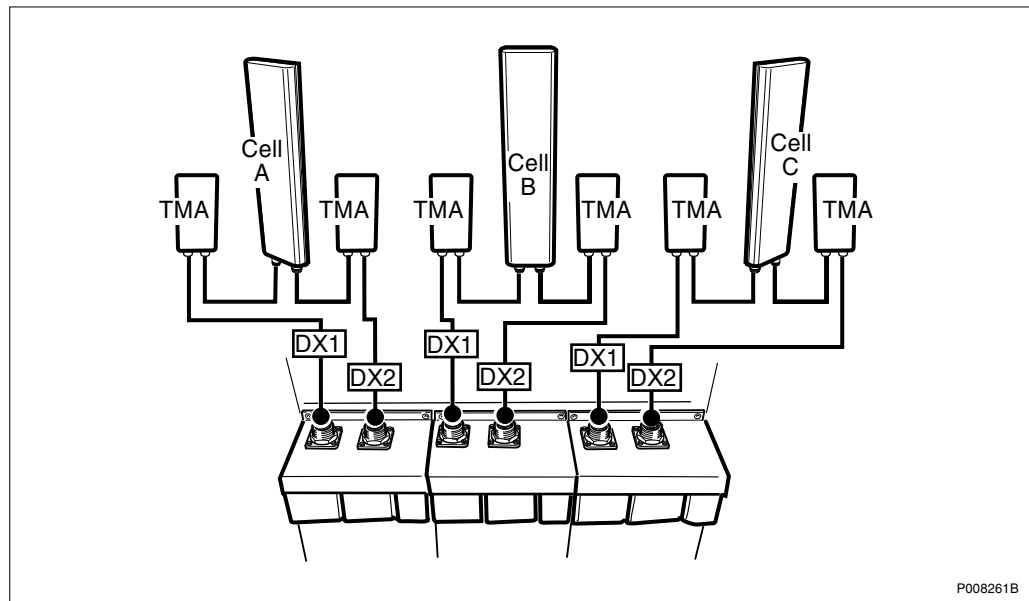

Figure 21 Configuration with TMA

Table 7 RBS 2106: 3x2 CDU-G and 3x4 CDU-G

Cell	CDU					ASU Connector
	CDU No.	Feeder label	Connector		Signal	
			CDU	Conn. field		
A	1	CellA: DX1	TX/RX1	A1	TX/RX A	S1
		CellA: DX2	TX/RX2	A2	TX/RX B	S2
B	2	CellB: DX1	TX/RX1	A3	TX/RX A	S3
		CellB: DX2	TX/RX2	A4	TX/RX B	S4
C	3	CellC: DX1	TX/RX1	A5	TX/RX A	S5
		CellC: DX2	TX/RX2	A6	TX/RX B	S6

From the configuration in the figures and table above, the following configurations can be derived:

- 1x2 CDU-G
- 2x2 CDU-G
- 1x4 CDU-G
- 2x4 CDU-G



6.2 1+1+2 CDU-G

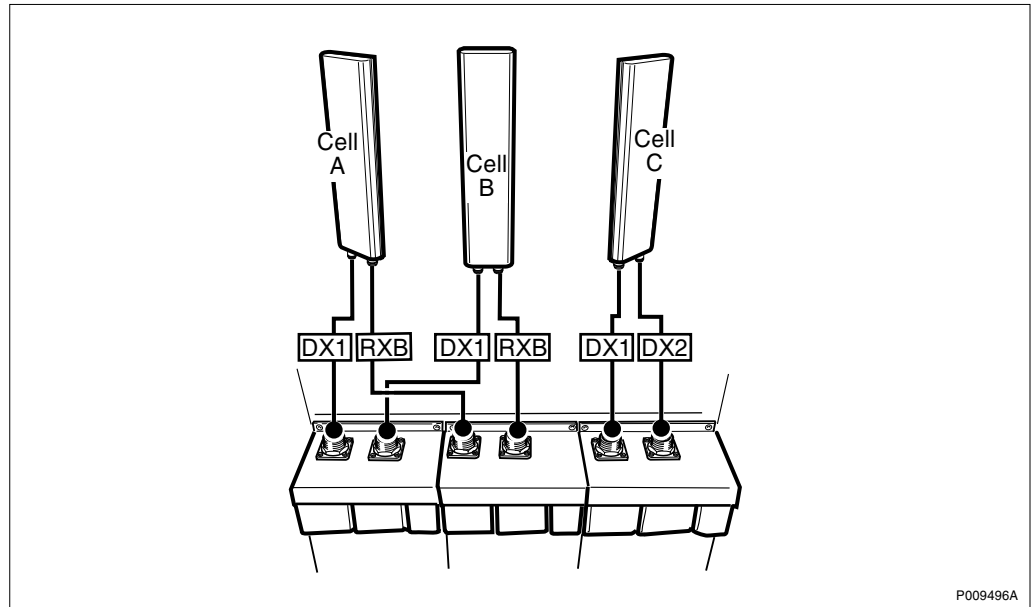

Figure 22 Configuration without TMA

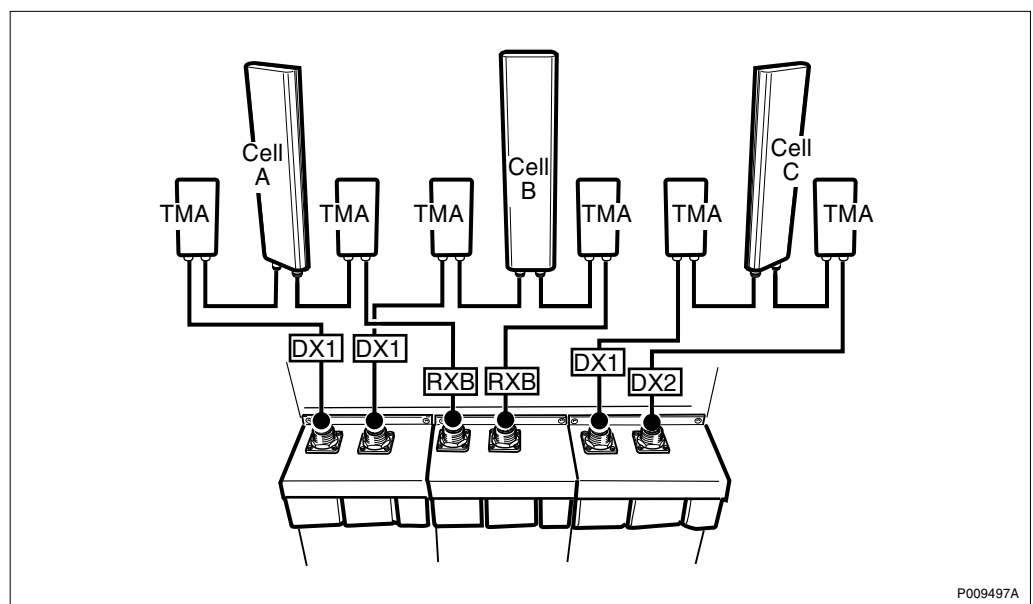

Figure 23 Configuration with TMA

Table 8 1+1+2 CDU-G

Cell	CDU					ASU Connector
	CDU No.	Feeder label	Connector		Signal	
			CDU	Conn. field		
A	1	CellA: DX1	TX/RX1	A1	TX/RX A	S1
	2	CellA: RXB	TX/RX1	A3	RX B	S3
B	1	CellB: DX1	TX/RX2	A2	TX/RX A	S2
	2	CellB: RXB	TX/RX2	A4	RX B	S4
C	3	CellC: DX1	TX/RX1	A5	TX/RX A	S5
		CellC: DX2	TX/RX2	A6	TX/RX B	S6

**6.3 1x4 CDU-G without hybrid combiner and 1x8 CDU-G with hybrid combiner**

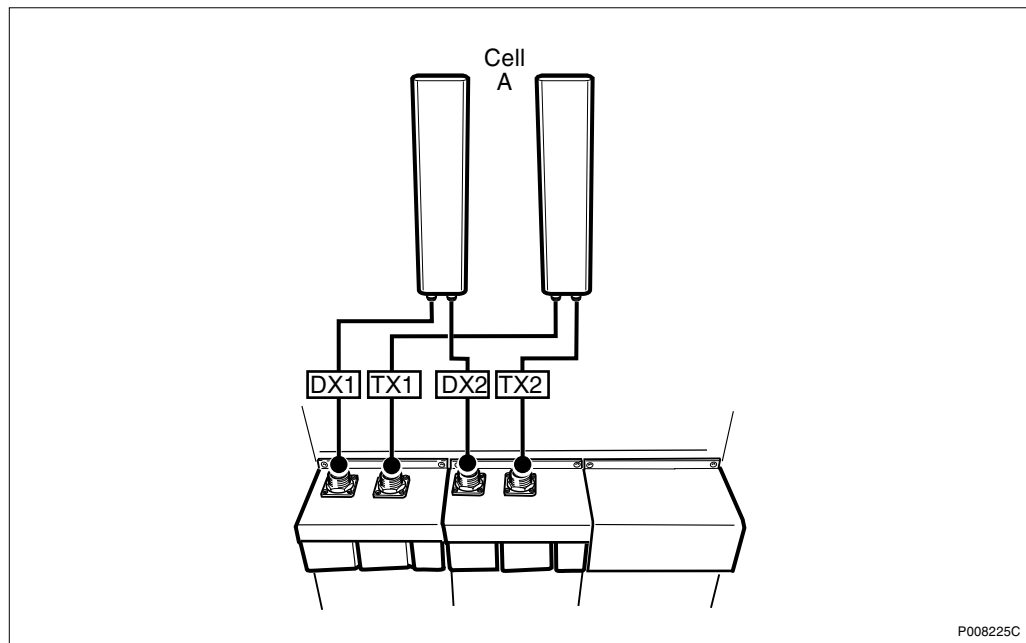

Figure 24 Configuration without TMA

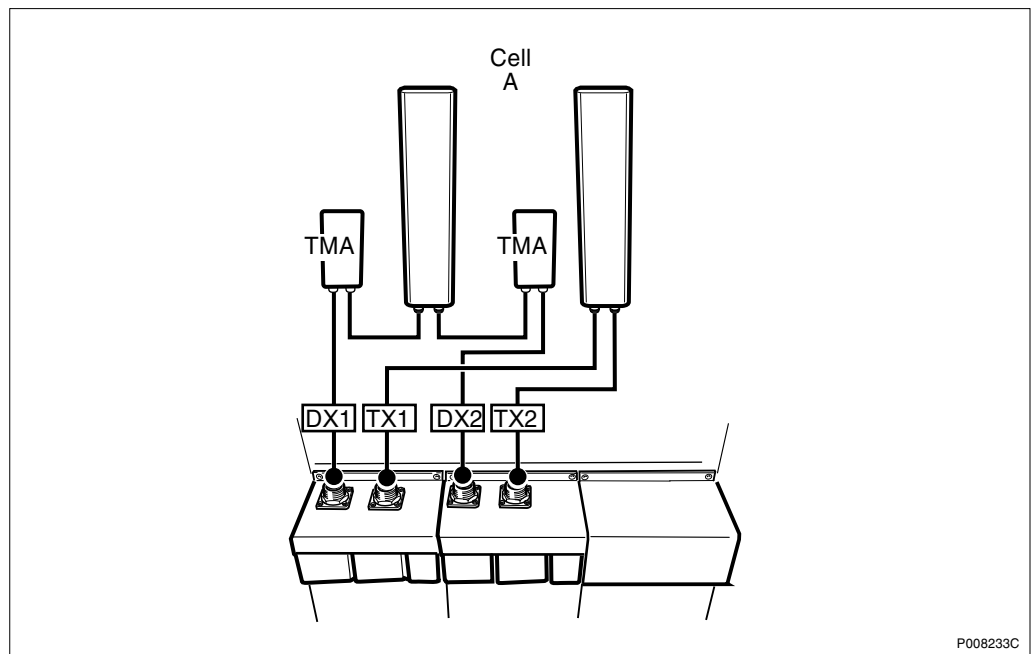

Figure 25 Configuration with TMA

Table 9 1x4 CDU-G without hybrid combiner and 1x8 CDU-G with hybrid combiner

Cell	CDU					ASU Connector
	CDU No.	Feeder label	Connector		Signal	
			CDU	Conn. field		
A	1	CellA: DX1	TX/RX1	A1	TX/RX A	S1
		CellA: TX1	TX/RX2	A2	RX B	
	2	CellA: DX2	TX/RX1	A3	TX/RX A	S3
		CellA: TX2	TX/RX2	A4	RX B	

**6.4 1x6 CDU-G without hybrid combiner and 1x12 CDU-G with hybrid combiner**

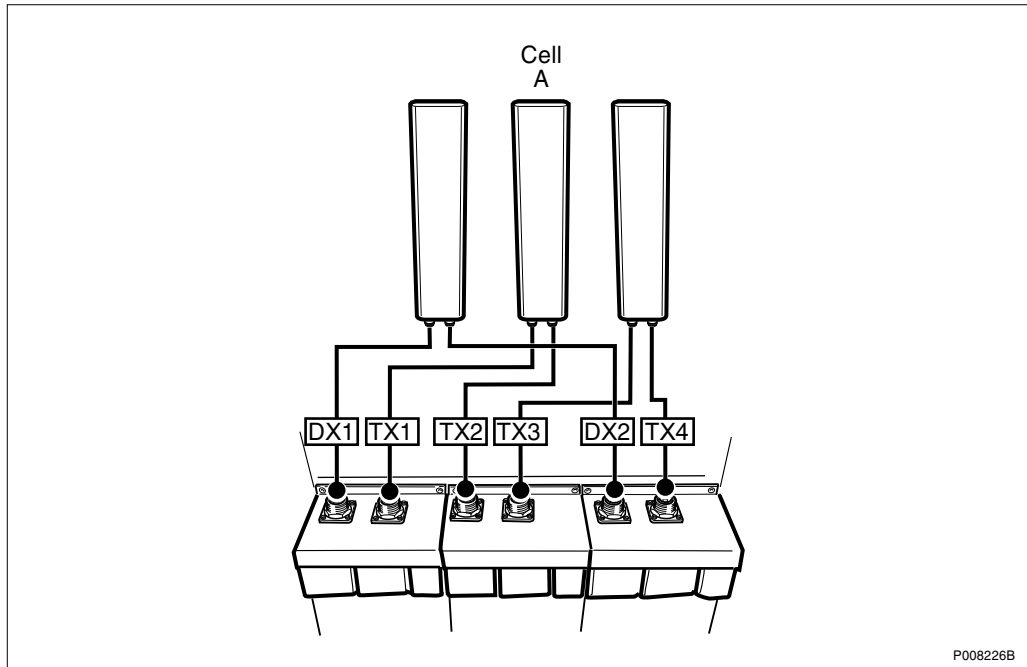

Figure 26 Configuration without TMA

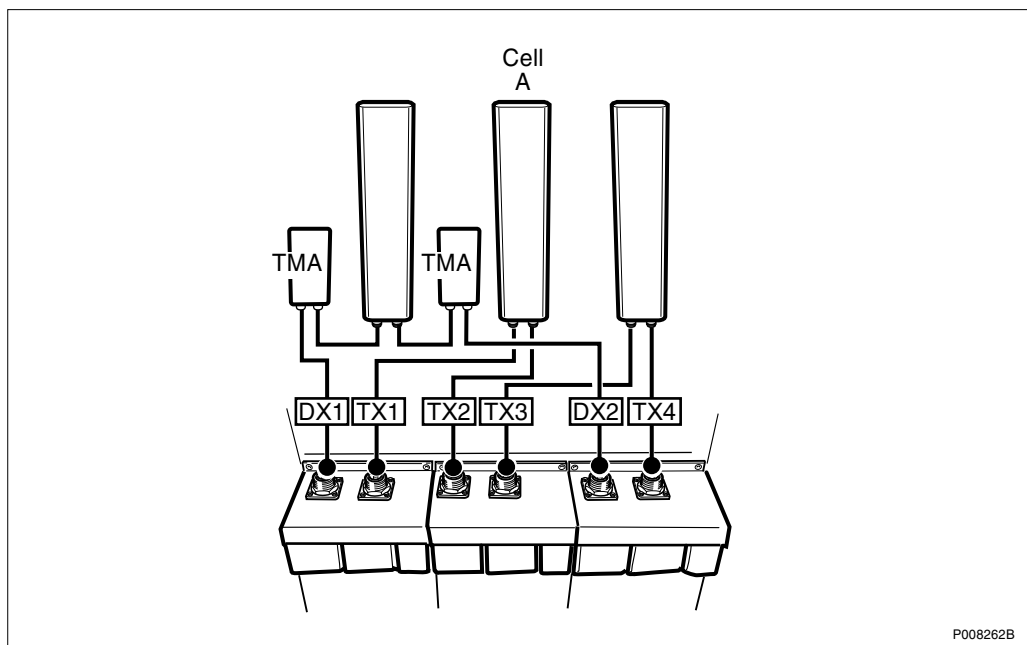

Figure 27 Configuration with TMA

Table 10 1x6 CDU-G without hybrid combiner and 1x12 CDU-G with hybrid combiner

Cell	CDU					ASU Connector
	CDU No.	Feeder label	Connector		Signal	
			CDU	Conn. field		
A	1	CellA: DX1	TX/RX1	A1	TX/RX A	S1
		CellA: TX1	TX/RX2	A2	TX	
	2	CellA: TX2	TX/RX1	A3	TX	
		CellA: TX3	TX/RX2	A4	TX	
	3	CellA: DX2	TX/RX1	A5	TX/RX B	S5
		CellA: TX4	TX/RX2	A6	TX	

6.5

2x6 CDU-G

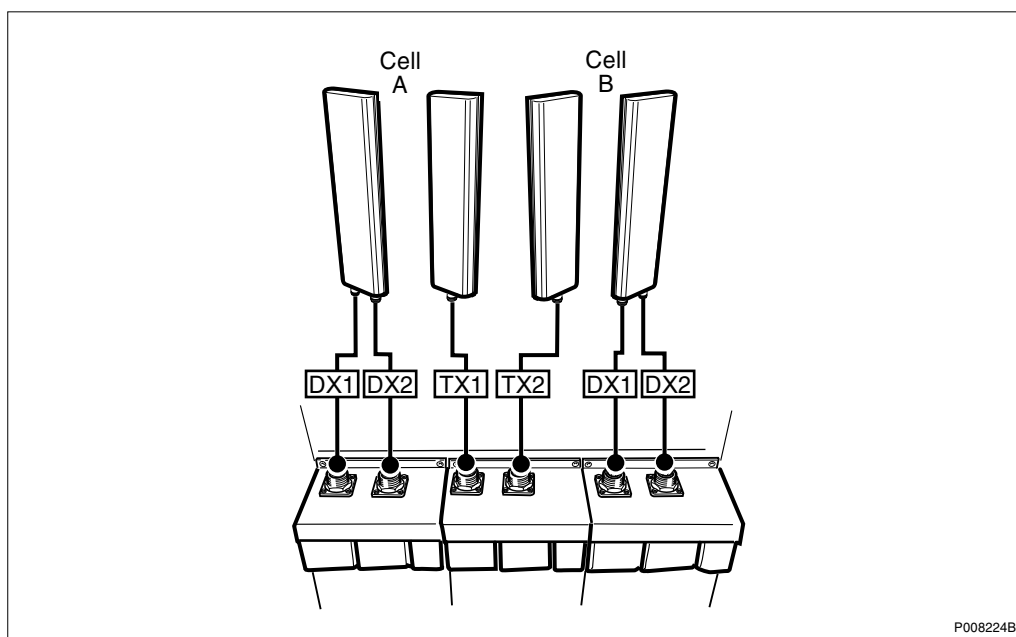

Figure 28 Configuration without TMA

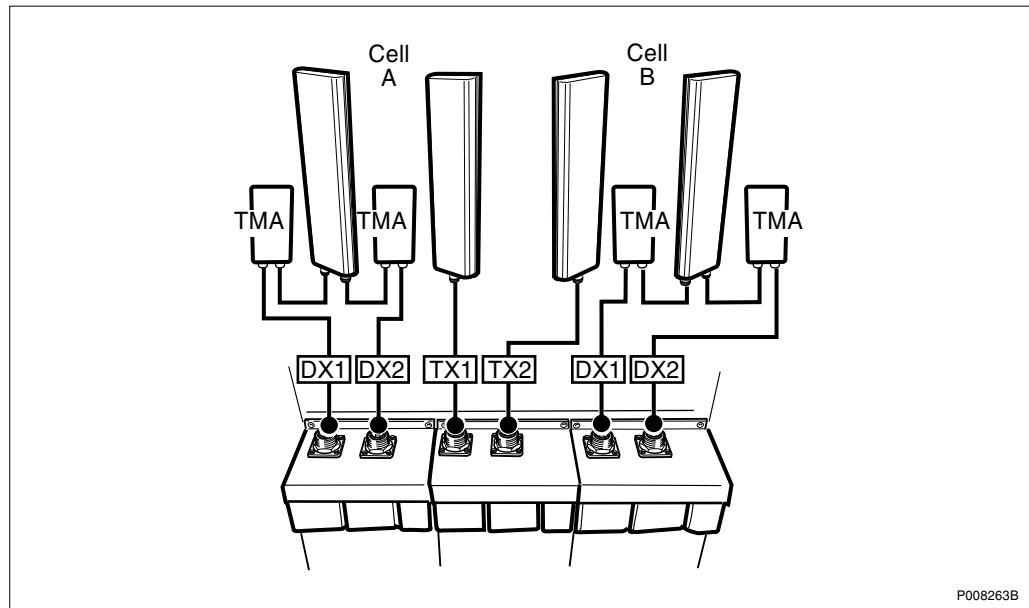

Figure 29 Configuration with TMA

Table 11 2x6 CDU-G

Cell	CDU					ASU Connector
	CDU No.	Feeder label	Connector		Signal	
			CDU	Conn. field		
A	1	CellA: DX1	TX/RX1	A1	TX/RX A	S1
		CellA: DX2	TX/RX2	A2	TX/RX B	S2
B	2	CellA: TX1	TX/RX1	A3	TX	
		CellB: TX2	TX/RX2	A4	TX	
	3	CellB: DX1	TX/RX1	A5	TX/RX A	S5
		CellB: DX2	TX/RX2	A6	TX/RX B	S6

# RBS 2206

## Antenna Configurations

### Description

This document describes the antenna configurations that are possible for the RBS 2206.

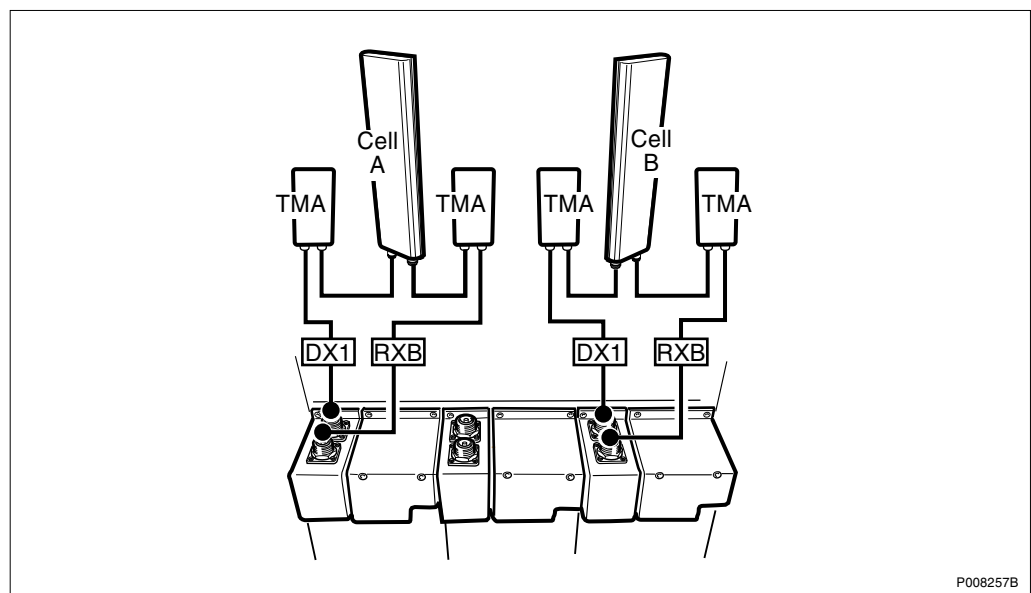

# Contents

<b>1</b>	<b>Introduction</b>	<b>3</b>
<b>2</b>	<b>Antenna Connection Field</b>	<b>4</b>
<b>3</b>	<b>CDU-F Antenna Connections</b>	<b>5</b>
<b>4</b>	<b>CDU-F Configurations</b>	<b>6</b>
4.1	3x2 CDU-F and 3x4 CDU-F	6
4.2	1x8 CDU-F	8
4.3	1x12 CDU-F	9
4.4	2x6 CDU-F	11
4.5	1x4 + 1x8 CDU-F	12
4.6	1x8 + 1x4 CDU-F	14
<b>5</b>	<b>CDU-G Antenna Connections</b>	<b>16</b>
<b>6</b>	<b>CDU-G Configurations</b>	<b>17</b>
6.1	3x2 CDU-G and 3x4 CDU-G	17
6.2	1+1+2 CDU-G	19
6.3	1x4 CDU-G without hybrid combiner and 1x8 CDU-G with hybrid combiner	20
6.4	1x6 CDU-G without hybrid combiner and 1x12 CDU-G with hybrid combiner	22
6.5	2x6 CDU-G	23



## 1 Introduction

The various configurations available for cabinets are described according to the following example:

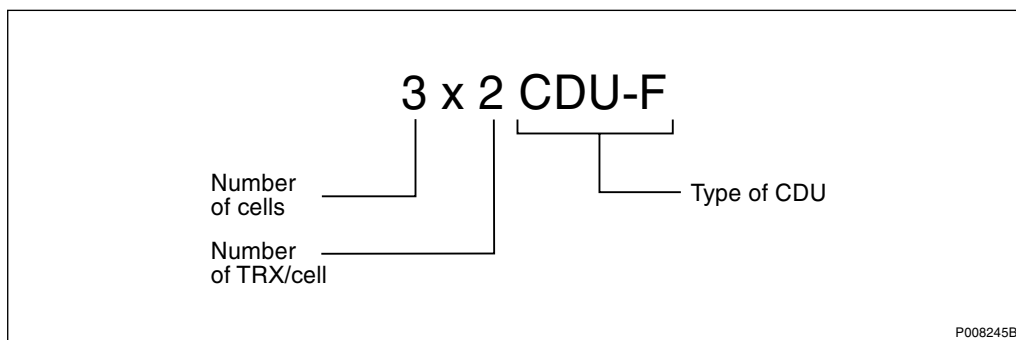

*Figure 1* CDU configuration key

In the example above, the cabinet is configured for three cells, each using two TRXs. The total number TRXs is thus six in this case. The CDU is type CDU-F.

**Note:** If TMA is used the bias injectors must be installed.

## 2 Antenna Connection Field

This section describes the cabling from the antenna connection field to the ASU.

The RF cables between each CDU and its associated TRUs are standardised and do not normally change.

The figure below gives an overview of the antenna sharing connectors and cabling from the ASU.

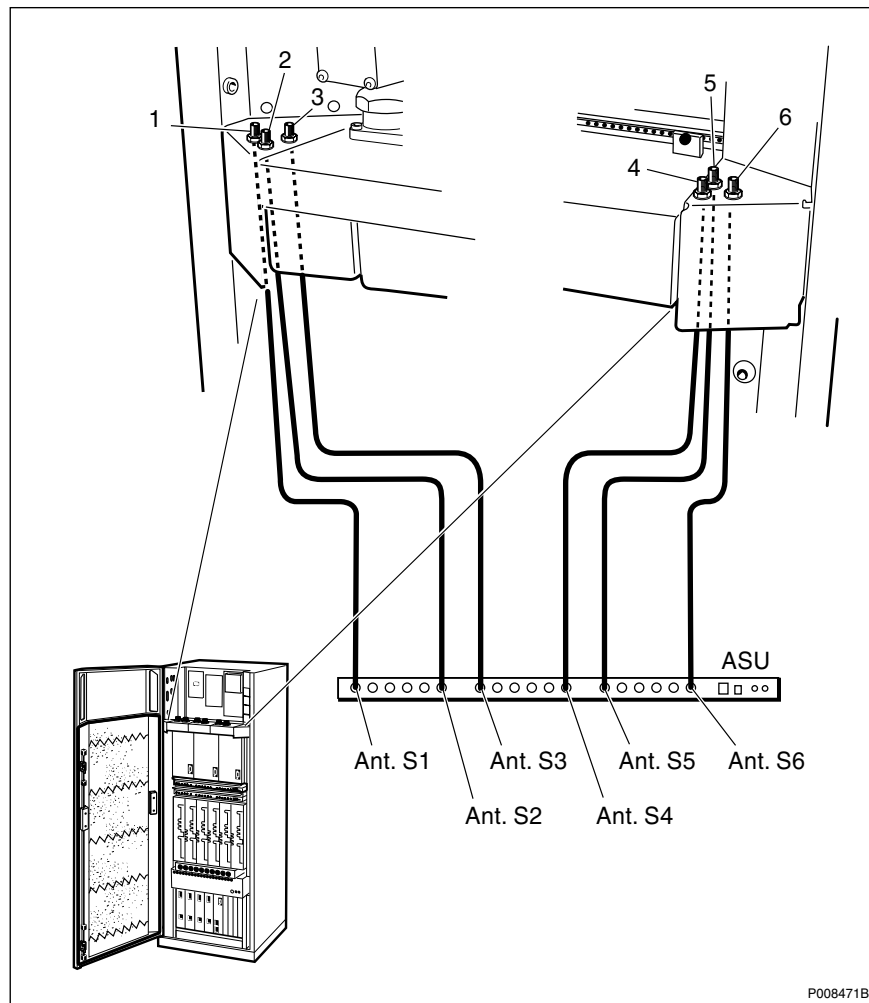

Figure 2 Cabling between ASU and antenna sharing connectors

### 3 CDU-F Antenna Connections

The antenna connectors are located on the top of the CDU, see *figures below*.

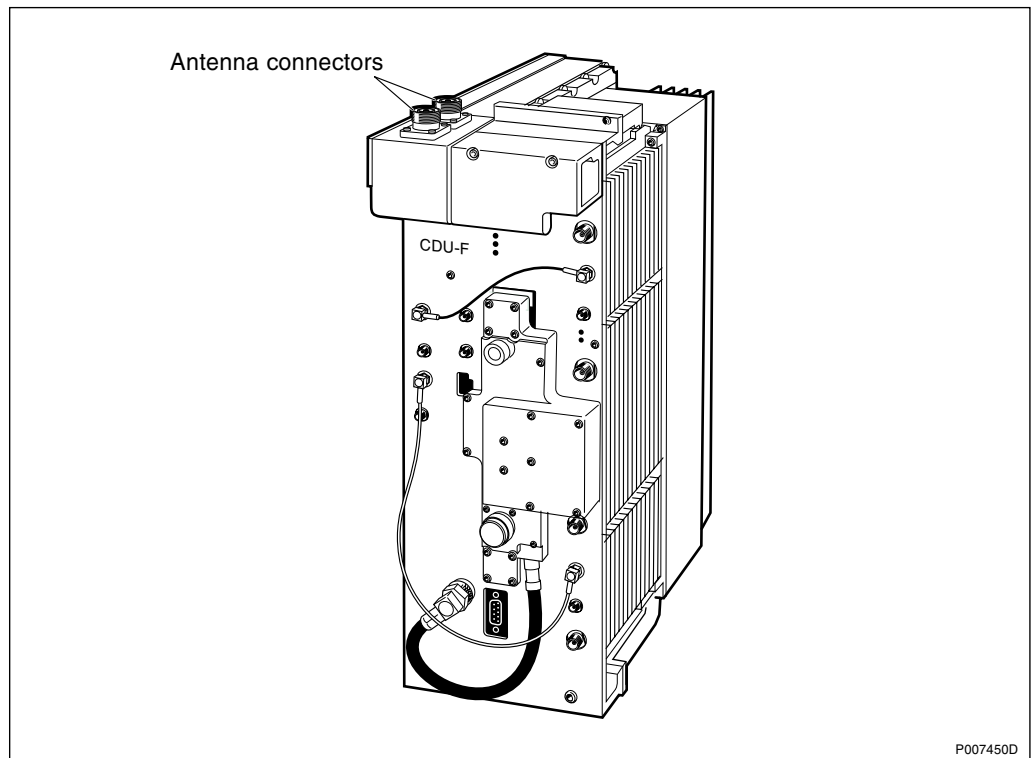

Figure 3 CDU-F layout

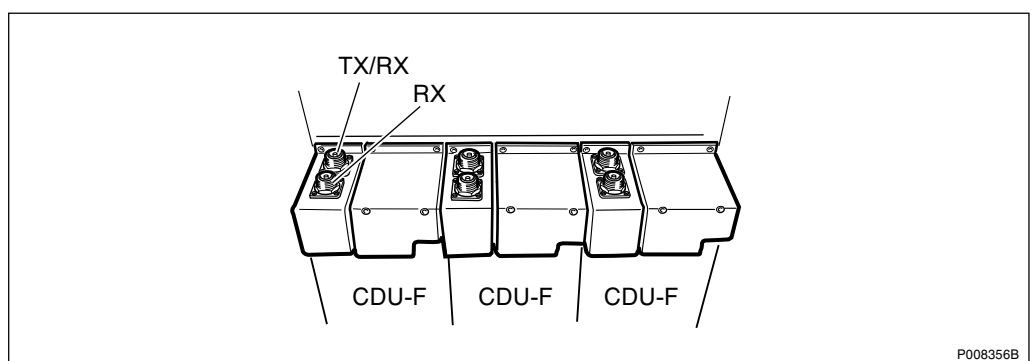

Figure 4 CDU-F antenna feeder connectors

## 4 CDU-F Configurations

**Note:** In the figures and tables that follow, only cabinets that are fully-equipped are shown. Configurations consisting of part of the fully-equipped cabinet are also possible to extract from the following figures and tables.

See *Figure 2 on page 4* and *Figure 4 on page 5* for a description of the column headers in the tables below.

### 4.1 3x2 CDU-F and 3x4 CDU-F

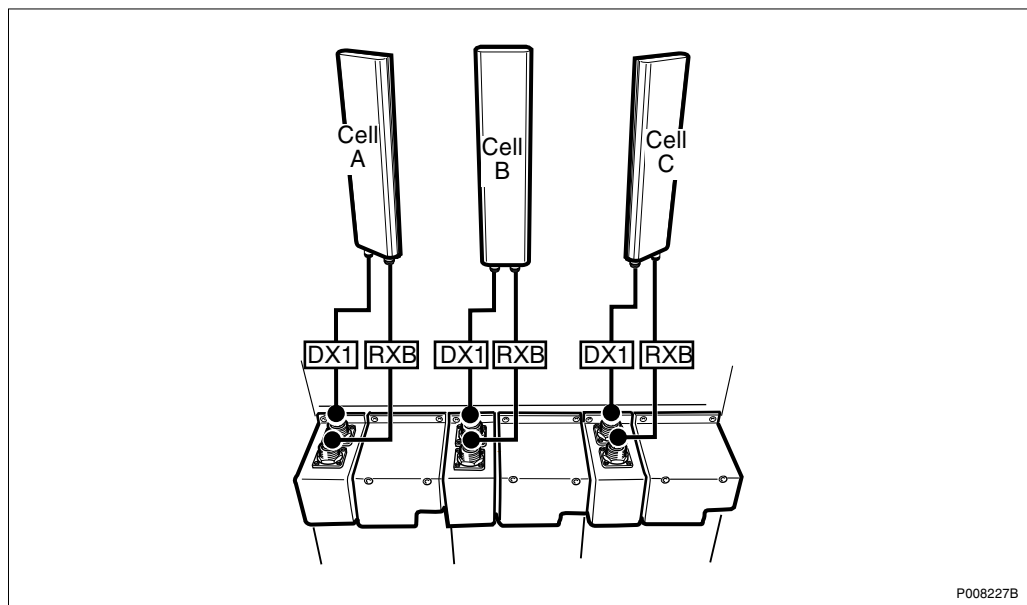

Figure 5 Configuration without TMA

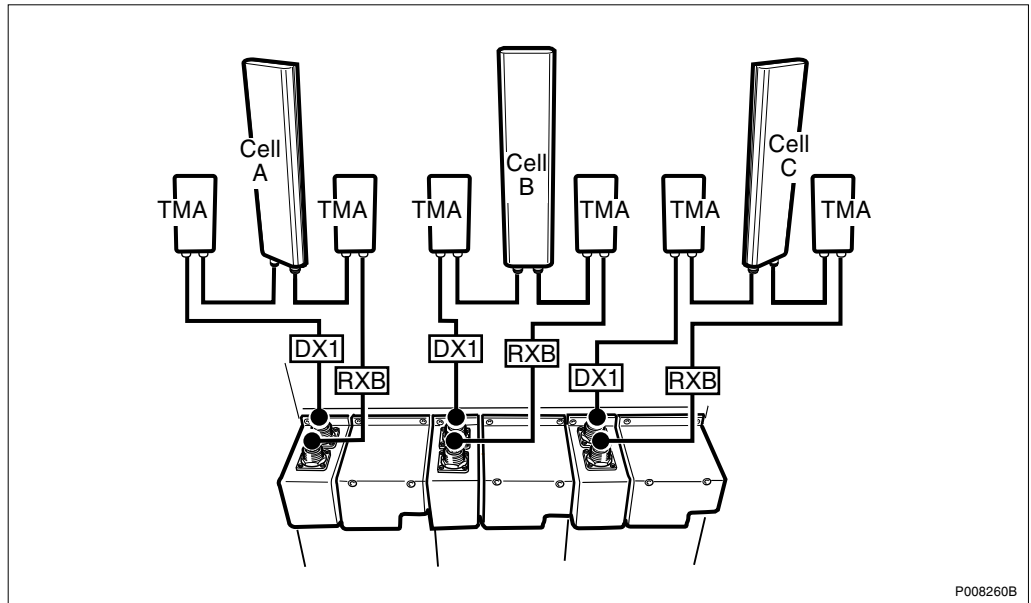

Figure 6 Configuration with TMA

Table 1 3x2 CDU-F and 3x4 CDU-F

Cell	CDU				ASU Connector
	CDU No.	Feeder label	CDU connector	Signal	
A	1	CellA: DX1	TX/RX	TX/RX A	1
		CellA: RXB	RX	RX B	2
B	2	CellB: DX1	TX/RX	TX/RX A	3
		CellB: RXB	RX	RX B	4
C	3	CellC: DX1	TX/RX	TX/RX A	5
		CellC: RXB	RX	RX B	6

From the configuration shown in the figures and tables above, the following configurations can be derived:

- 1x2 CDU-F
- 2x2 CDU-F
- 1x4 CDU-F
- 2x4 CDU-F

4.2

1x8 CDU-F

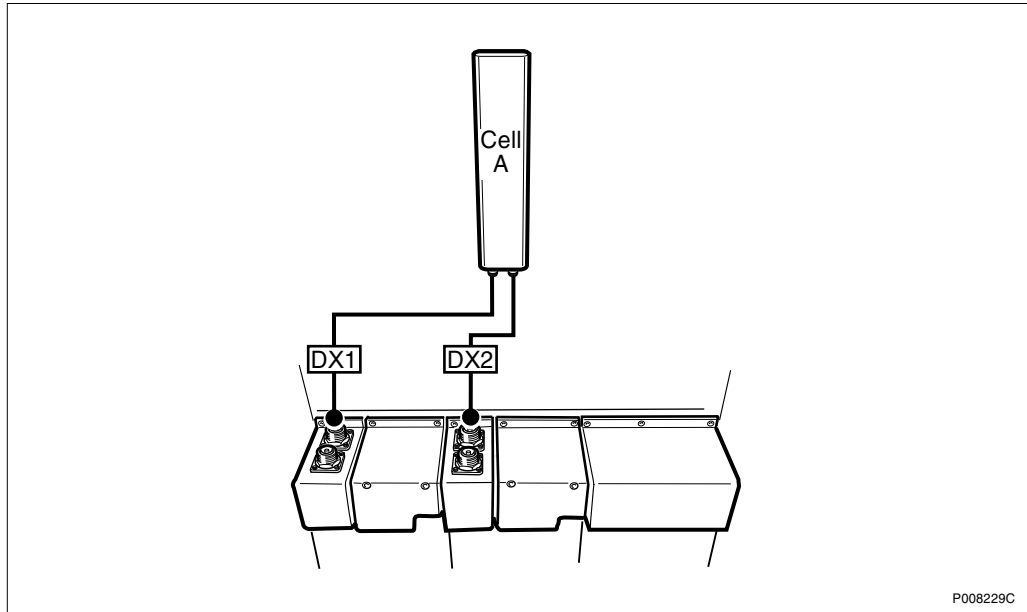

Figure 7 Configuration without TMA

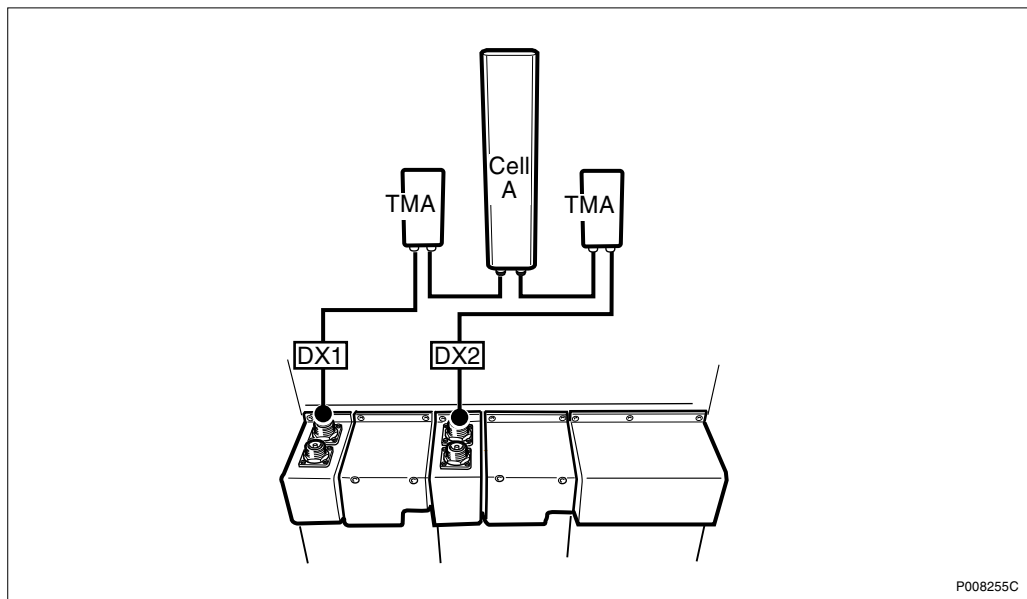

Figure 8 Configuration with TMA

Table 2 1x8 CDU-F

Cell	CDU				ASU Connector
	CDU No.	Feeder label	CDU connector	Signal	
A	1	CellA: DX1	TX/RX	TX/RX A	1
	2	CellA: DX2	TX/RX	TX/RX B	3

## 4.3

## 1x12 CDU-F

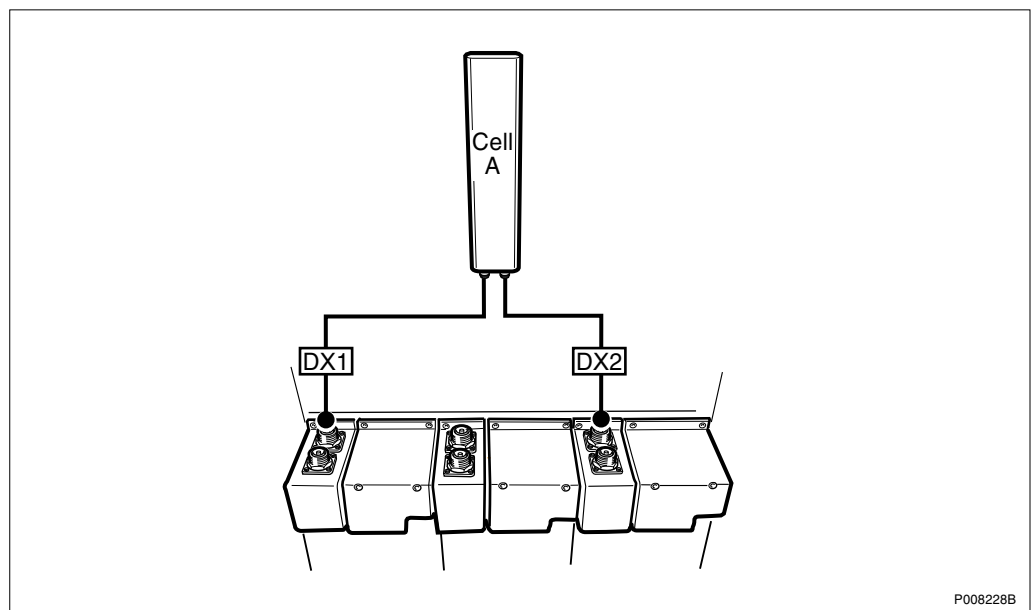

Figure 9 Configuration without TMA

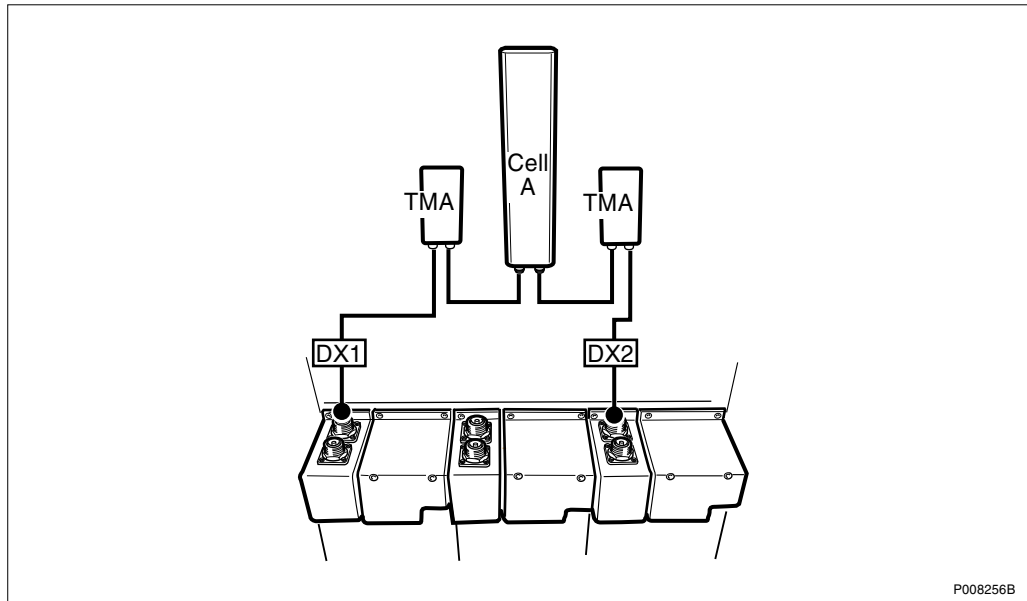

Figure 10 Configuration with TMA

Table 3 1x12 CDU-F

Cell	CDU				ASU Connector
	CDU No.	Feeder label	CDU connector	Signal	
A	1	CellA: DX1	TX/RX	TX/RX A	1
	3	CellA: DX2	TX/RX	TX/RX B	5



**4.4 2x6 CDU-F**

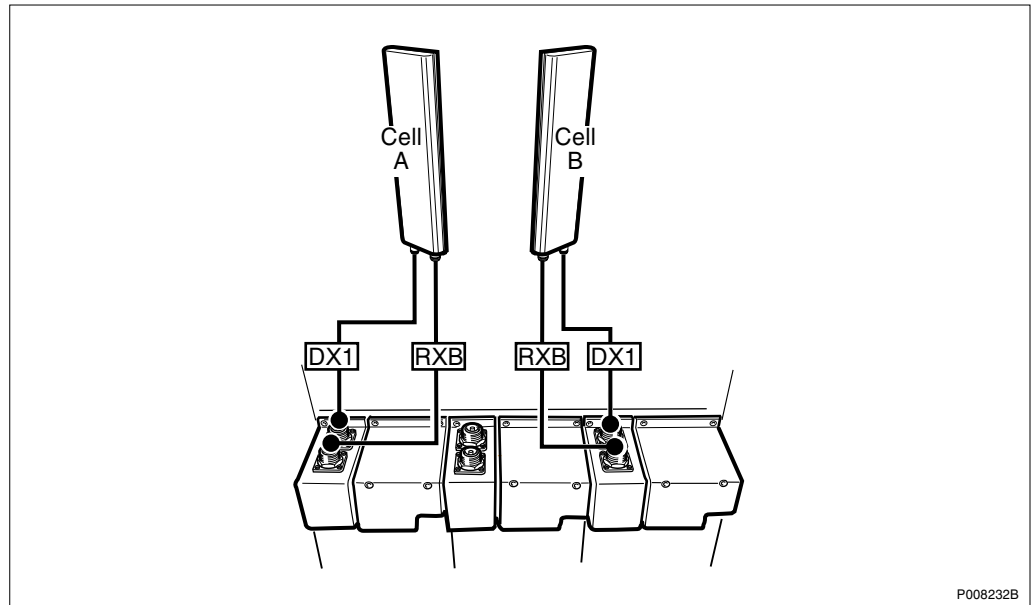

P008232B

Figure 11 Configuration without TMA

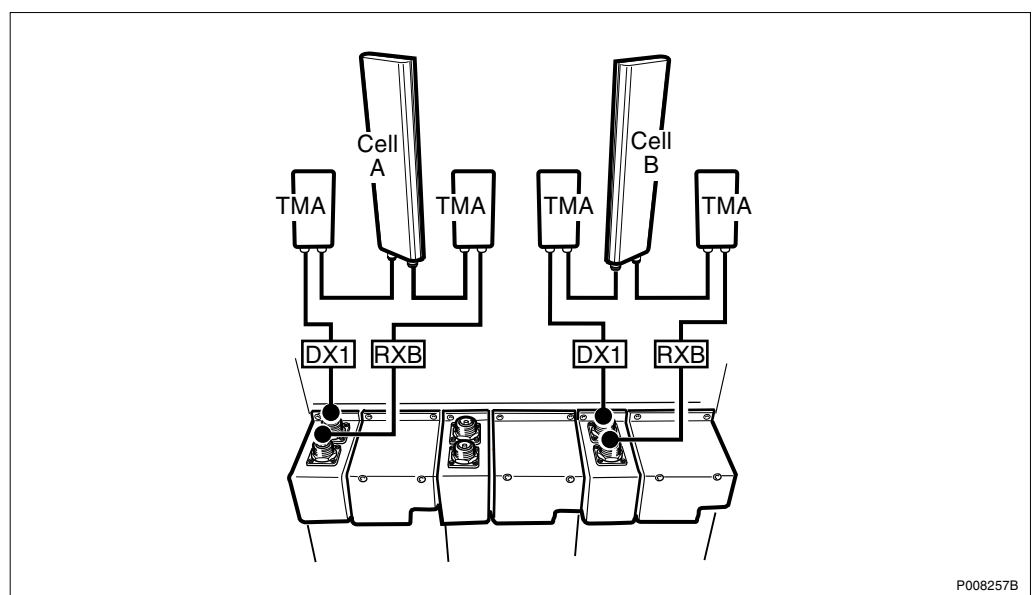

P008257B

Figure 12 Configuration with TMA

Table 4 2x6 CDU-F

Cell	CDU				ASU Connector
	CDU No.	Feeder label	CDU connector	Signal	
A	1	CellA: DX1	TX/RX	TX/RX A	1
		CellA: RXB	RX	RX B	2
B	3	CellB: DX1	TX/RX	TX/RX A	5
		CellB: RXB	RX	RX B	6

4.5

1x4 + 1x8 CDU-F

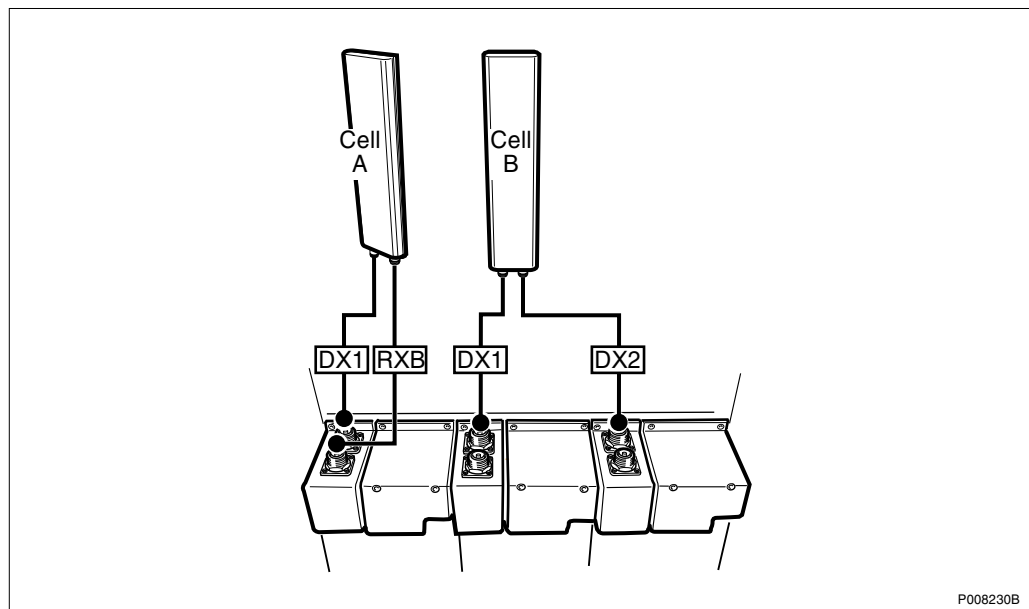

Figure 13 Configuration without TMA

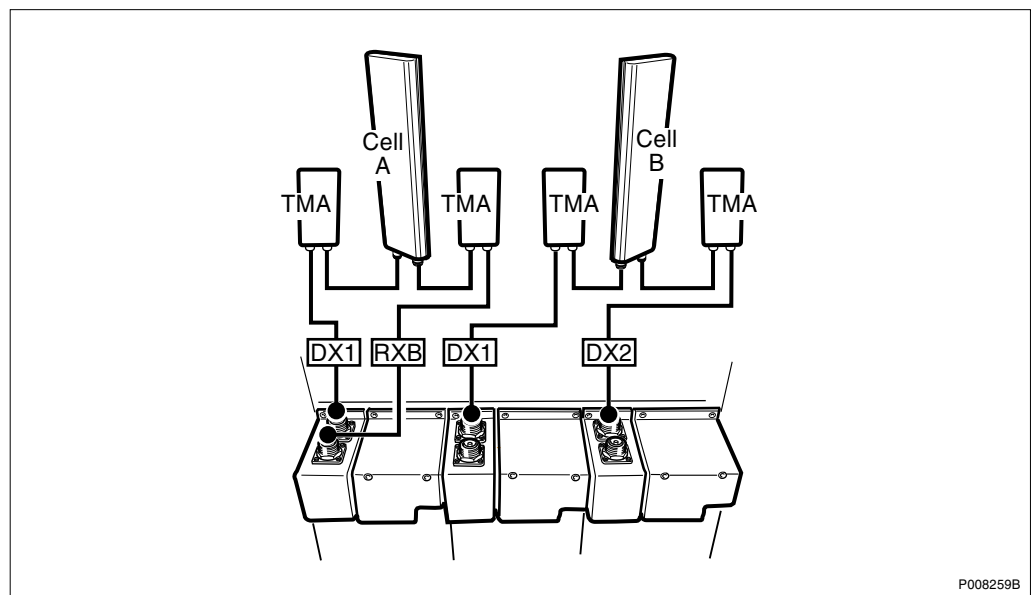

Figure 14 Configuration with TMA

Table 5 1x4+1x8 CDU-F

Cell	CDU				ASU Connector
	CDU No.	Feeder label	CDU connector	Signal	
A	1	CellA: DX1	TX/RX	TX/RX A	1
		CellA: RXB	RX	RX B	2
B	2	CellB: DX1	TX/RX	TX/RX B	3
	3	CellB: DX2	TX/RX	TX/RX B	5

**4.6 1x8 + 1x4 CDU-F**

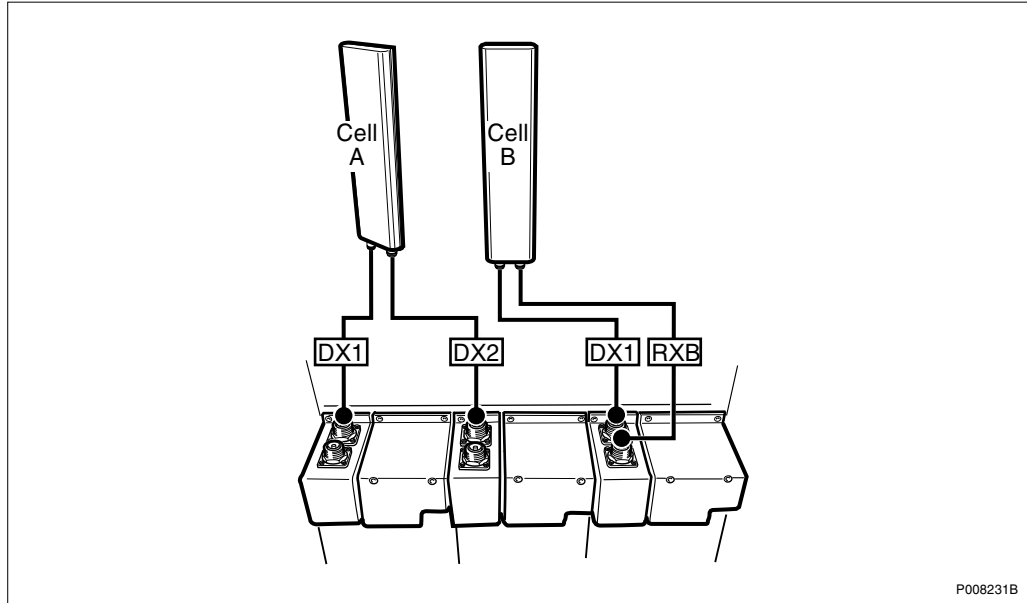

Figure 15 Configuration without TMA

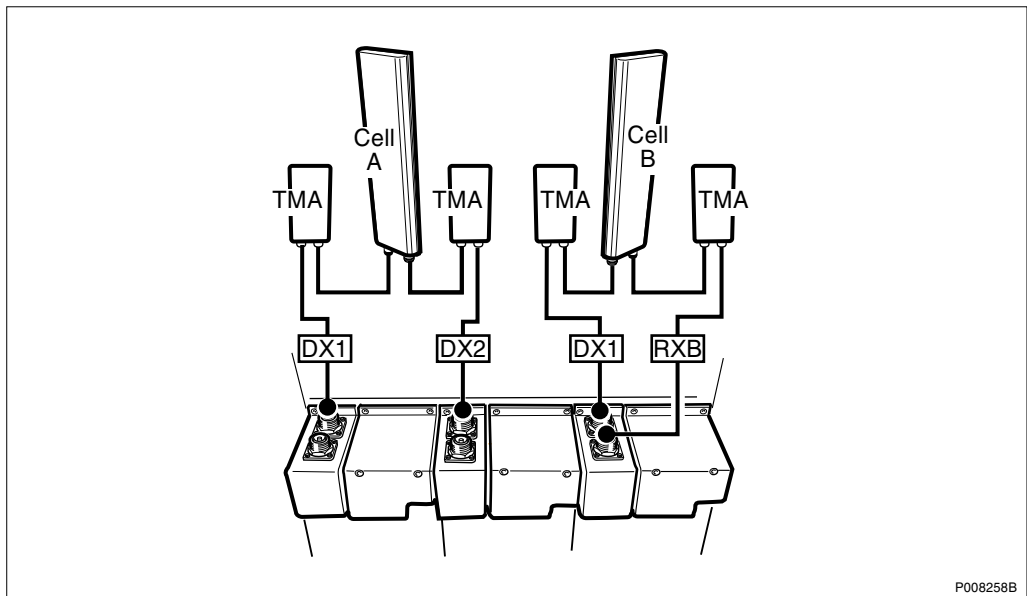

Figure 16 Configuration with TMA

*Table 6 1x8+1x4 CDU-F*

<b>Cell</b>	<b>CDU</b>				<b>ASU Connector</b>
	<b>CDU No.</b>	<b>Feeder label</b>	<b>CDU connector</b>	<b>Signal</b>	
A	1	CellA: DX1	TX/RX	TX/RX A	1
	2	CellA: DX2	TX/RX	TX/RX B	3
B	3	CellB: DX1	TX/RX	TX/RX A	5
		CellB: RXB	RX	RX B	6

## 5 CDU-G Antenna Connections

The antenna connectors are located on the top of the CDU, see *figures below*.

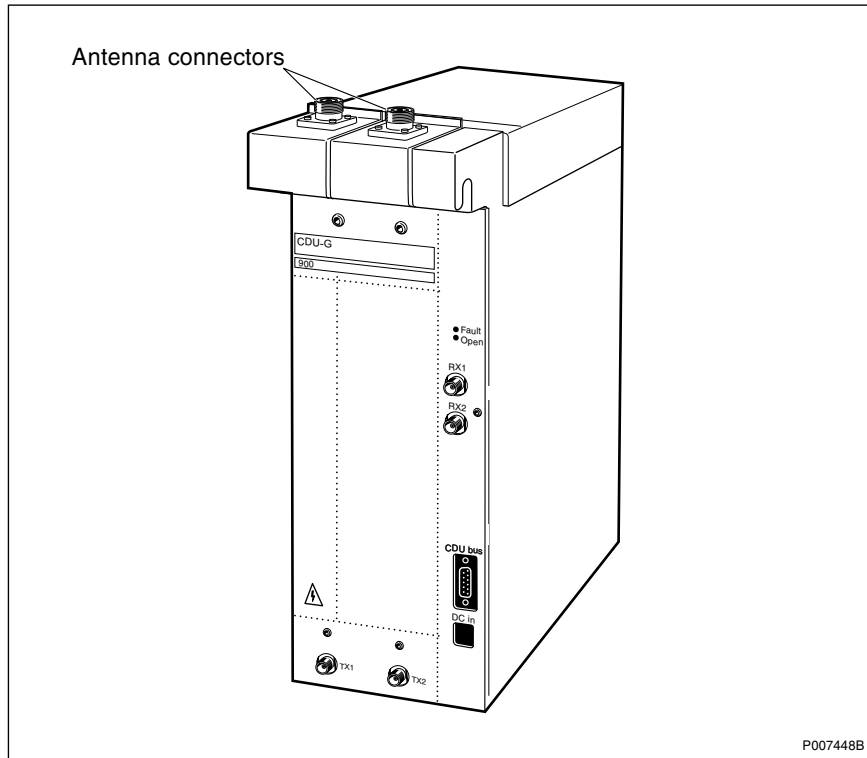

Figure 17 CDU-G layout

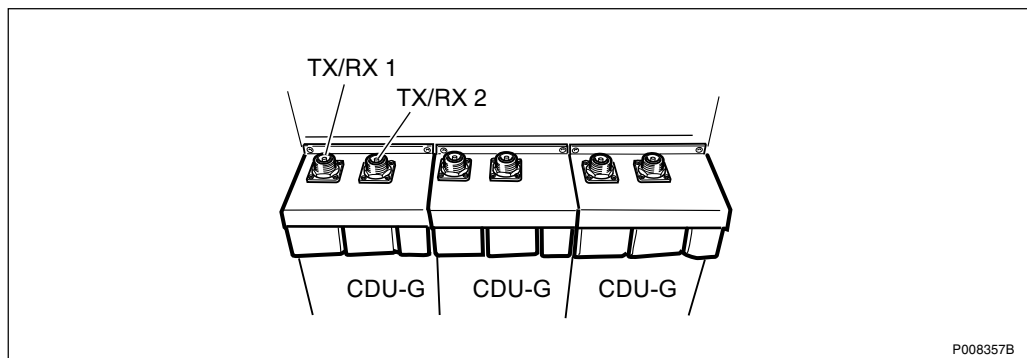

Figure 18 CDU-G antenna feeder connectors

## 6 CDU-G Configurations

**Note:** In the figures and tables that follow, only cabinets that are fully-equipped are shown. Configurations consisting of part of the fully-equipped cabinet are also possible to extract from the following figures and tables.

See *Figure 2 on page 4* and *Figure 18 on page 16* for a description of the column headers in the tables below.

### 6.1 3x2 CDU-G and 3x4 CDU-G

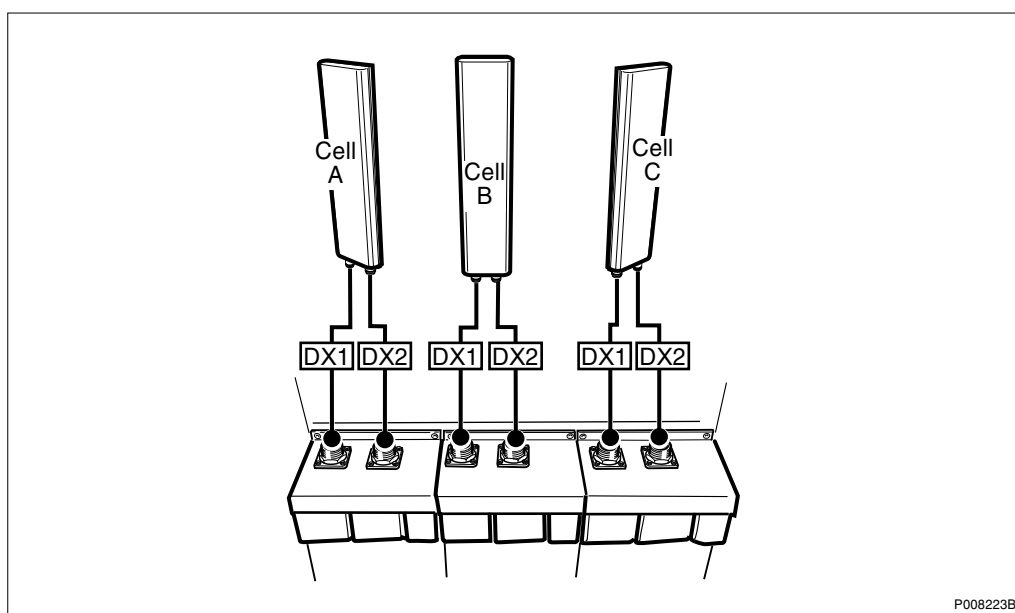

Figure 19 Configuration without TMA

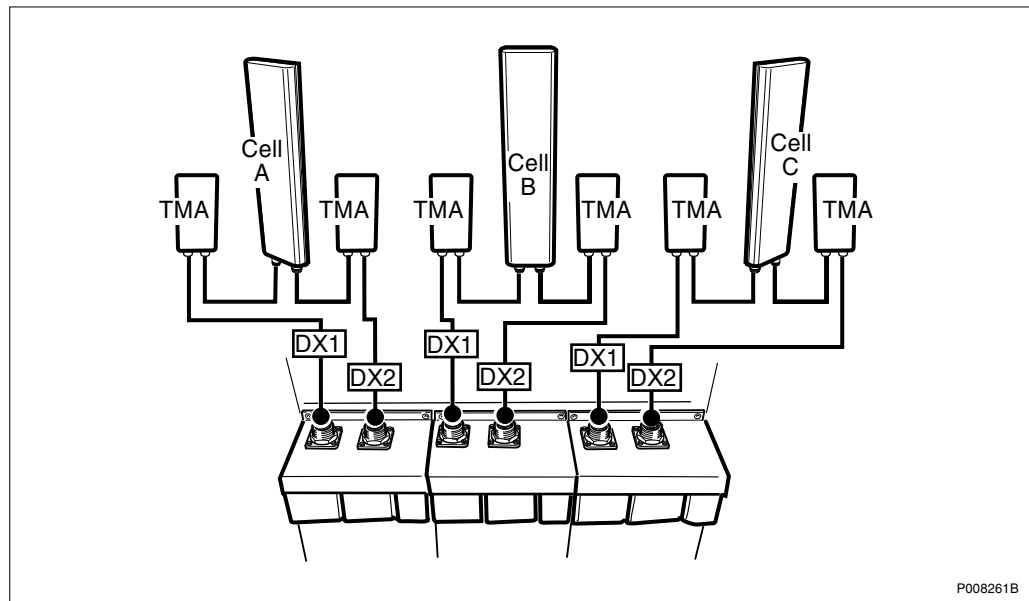

Figure 20 Configuration with TMA

Table 7 3x2 CDU-G and 3x4 CDU-G

Cell	CDU				ASU Connector
	CDU No.	Feeder label	CDU connector	Signal	
A	1	CellA: DX1	TX/RX1	TX/RX A	1
		CellA: DX2	TX/RX2	TX/RX B	2
B	2	CellB: DX1	TX/RX1	TX/RX A	3
		CellB: DX2	TX/RX2	TX/RX B	4
C	3	CellC: DX1	TX/RX1	TX/RX A	5
		CellC: DX2	TX/RX2	TX/RX B	6

From the configuration in the figures and tables above, the following configurations can be derived:

- 1x2 CDU-G
- 2x2 CDU-G
- 1x4 CDU-G
- 2x4 CDU-G



### 6.2 1+1+2 CDU-G

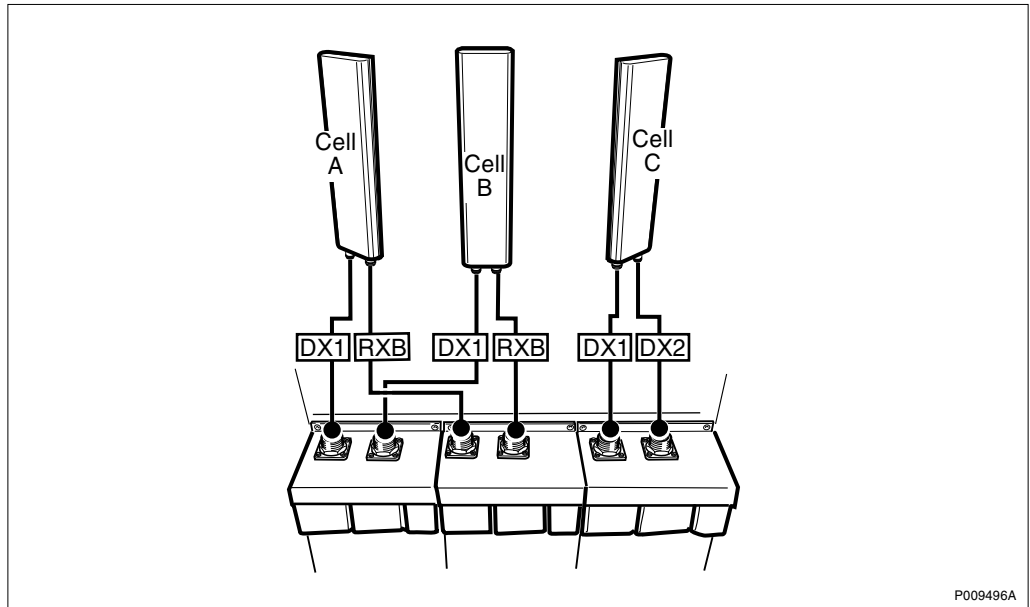

Figure 21 Configuration without TMA

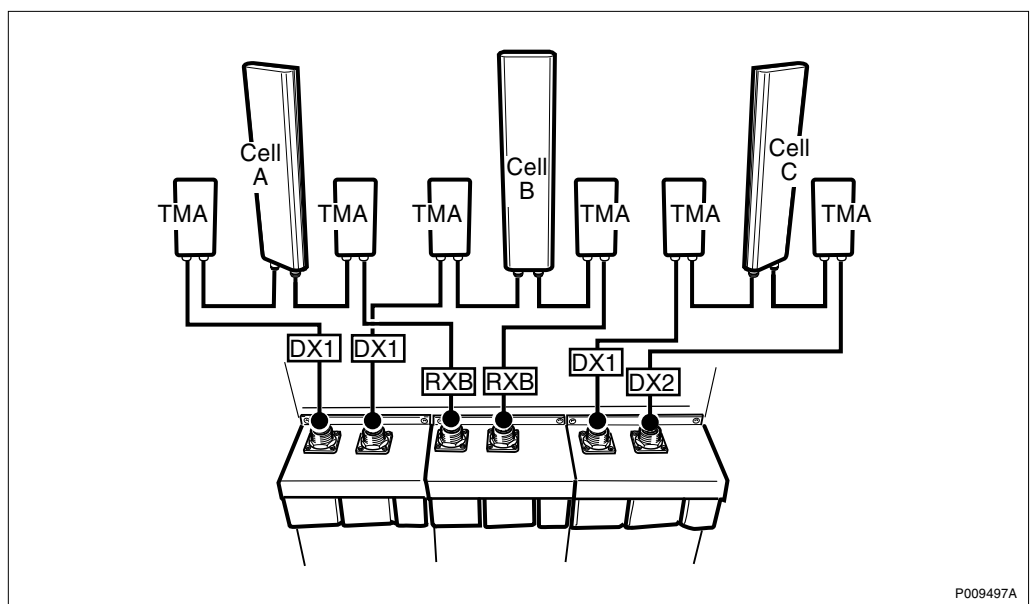

Figure 22 Configuration with TMA

Table 8 1+1+2 CDU-G

Cell	CDU				ASU Connector
	CDU No.	Feeder label	CDU connector	Signal	
A	1	CellA: DX1	TX/RX1	TX/RX A	1
	2	CellA: RXB	TX/RX1	RX B	3
B	1	CellB: DX1	TX/RX2	TX/RX A	2
	2	CellB: RXB	TX/RX2	RX B	4
C	3	CellC: DX1	TX/RX1	TX/RX A	5
		CellC: DX2	TX/RX2	TX/RX B	6

**6.3 1x4 CDU-G without hybrid combiner and 1x8 CDU-G with hybrid combiner**

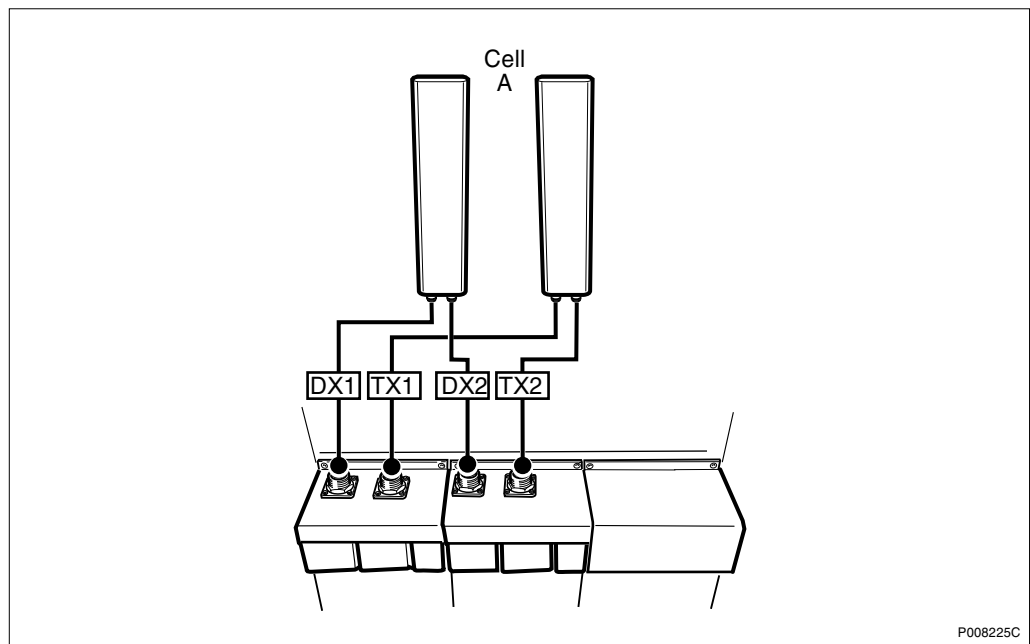
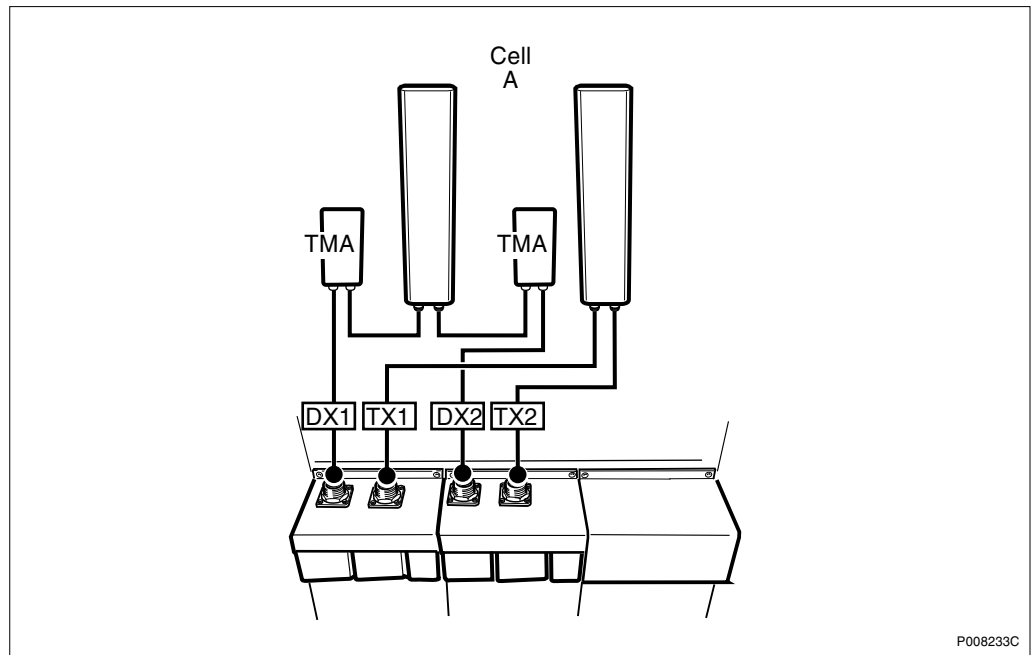

Figure 23 Configuration without TMA



P008233C

Figure 24 Configuration with TMA

Table 9 1x4 CDU-G without hybrid combiner and 1x8 CDU-G with hybrid combiner

Cell	CDU				ASU Connector
	CDU No.	Feeder label	CDU connector	Signal	
A	1	CellA: DX1	TX/RX1	TX/RX A	1
		CellA: TX1	TX/RX2	TX	
	2	CellA: DX2	TX/RX1	TX/RX B	3
		CellA: TX2	TX/RX2	TX	

**6.4 1x6 CDU-G without hybrid combiner and 1x12 CDU-G with hybrid combiner**

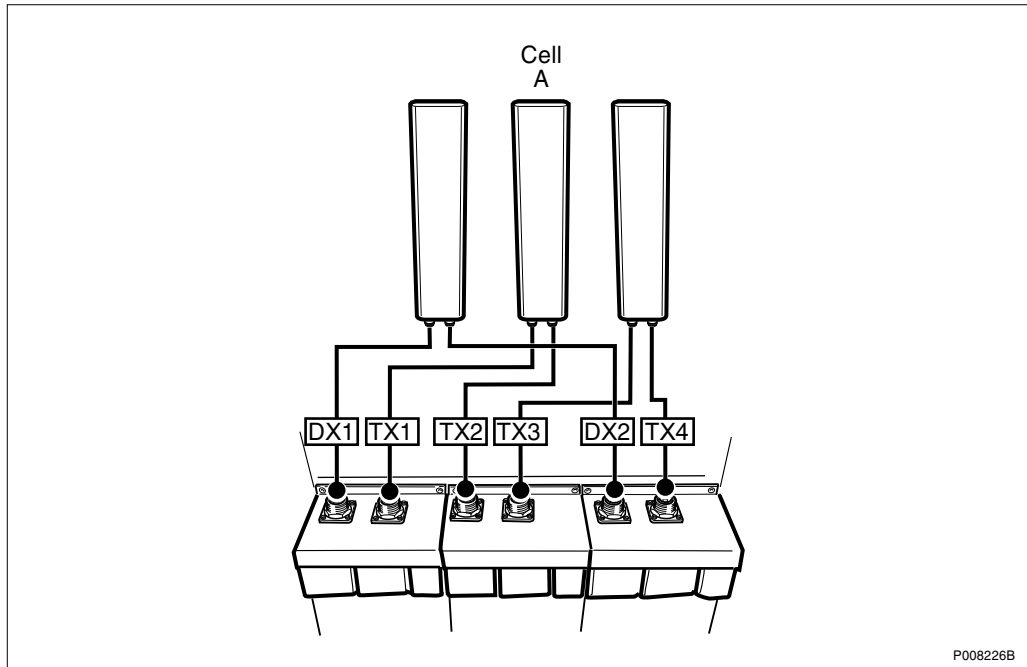

Figure 25 Configuration without TMA

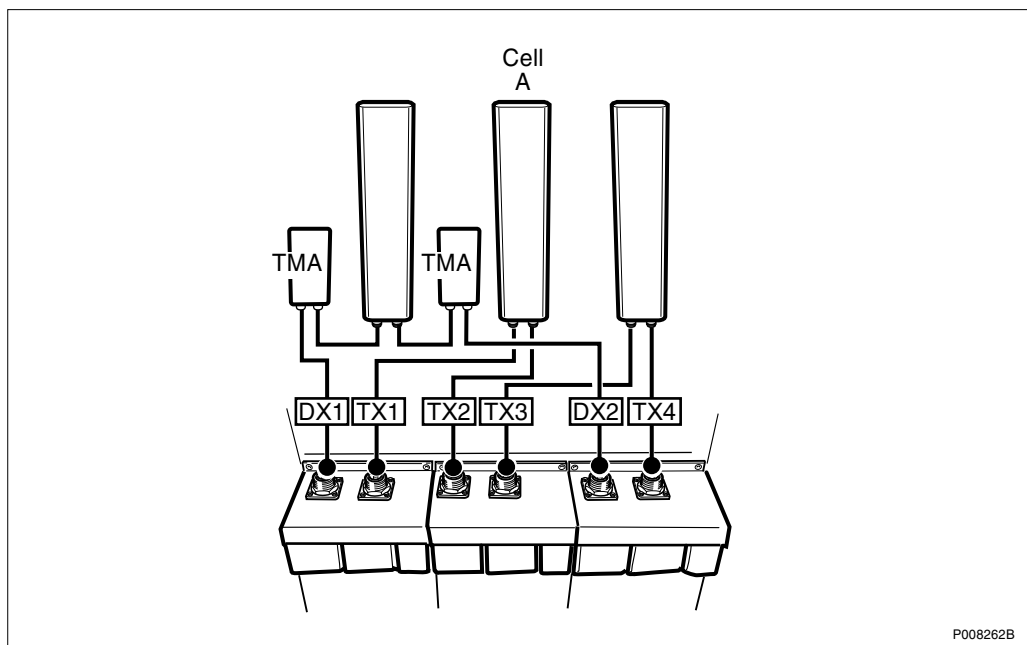

Figure 26 Configuration with TMA

Table 10 1x6 CDU-G without hybrid combiner and 1x12 CDU-G with hybrid combiner

Cell	CDU				ASU Connector
	CDU No.	Feeder label	CDU connector	Signal	
A	1	CellA: DX1	TX/RX1	TX/RX A	1
		CellA: TX1	TX/RX2	TX	
	2	CellA: TX2	TX/RX1	TX	
		CellA: TX3	TX/RX2	TX	
	3	CellA: DX2	TX/RX1	TX/RX B	5
		CellA: TX4	TX/RX2	TX	

6.5

2x6 CDU-G

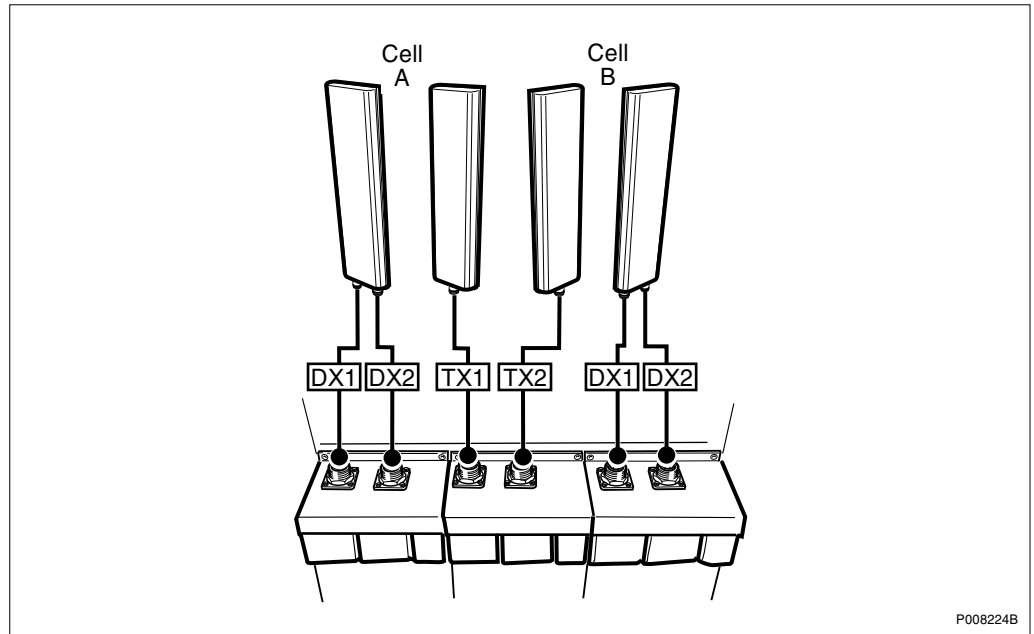

Figure 27 Configuration without TMA

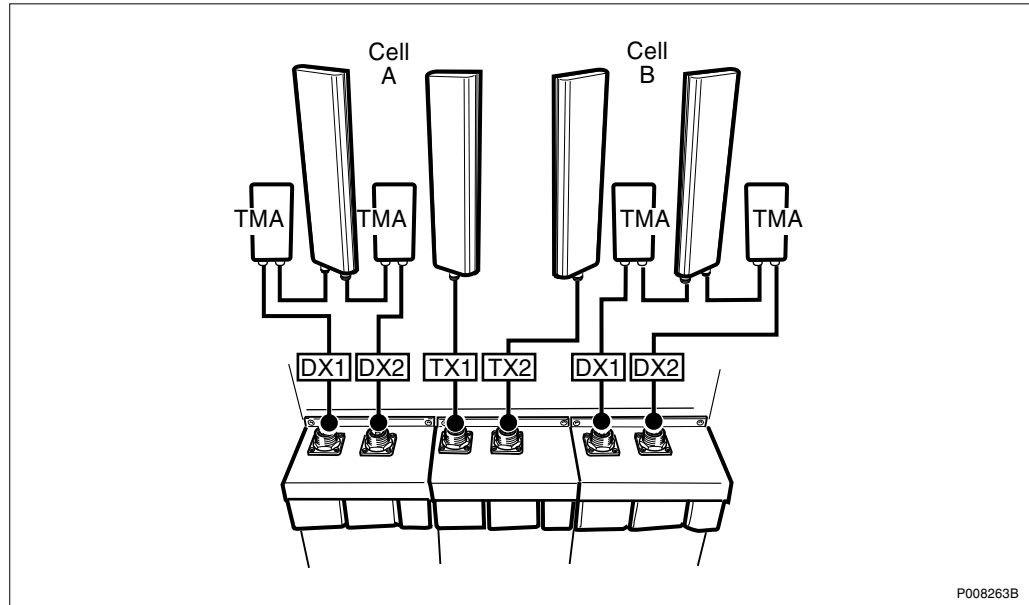

Figure 28 Configuration with TMA

Table 11 2x6 CDU-G

Cell	CDU				ASU Connector
	CDU No.	Feeder label	CDU connector	Signal	
A	1	CellA: DX1	TX/RX1	TX/RX A	1
		CellA: DX2	TX/RX2	TX/RX B	2
B	2	CellA: TX1	TX/RX1	TX	
		CellB: TX2	TX/RX2	TX	
B	3	CellB: DX1	TX/RX1	TX/RX A	5
		CellB: DX2	TX/RX2	TX/RX B	6

# ACCU-01

AC Connection Unit

## Unit Description

EN/LZT 720 0229 R1A

The AC Connection Unit (ACCU) distributes primary power to the Power Supply Units (PSU).

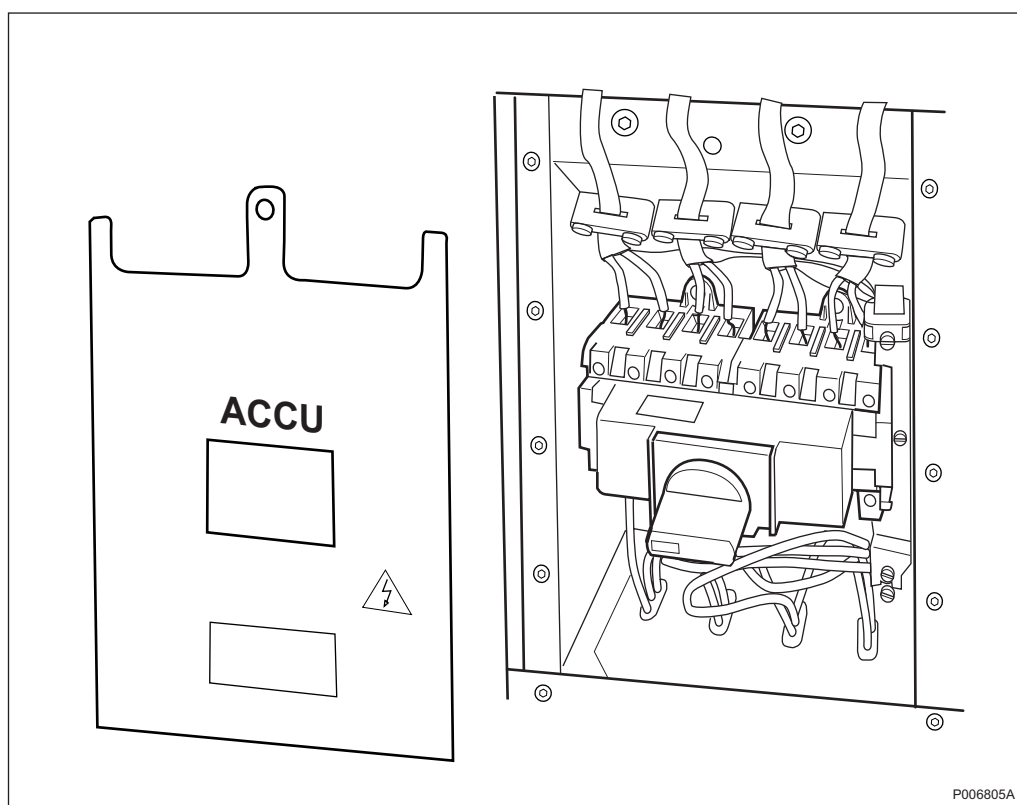

## Contents

<b>1</b>	<b>Product Overview</b>	<b>3</b>
1.1	Main Functions	3
<b>2</b>	<b>Dimensions</b>	<b>3</b>
<b>3</b>	<b>Function Description</b>	<b>3</b>
<b>4</b>	<b>Interfaces</b>	<b>4</b>
4.1	Signal and Power Interfaces	5
4.2	Operator Interface	5



# 1 Product Overview

The ACCU distributes primary power to the PSUs. There is only one ACCU in the cabinet, depending on the type of incoming power.

## 1.1 Main Functions

The ACCU has the following functions:

- Terminates incoming AC mains cables
- Disconnects incoming AC mains
- Filters EMC

# 2 Dimensions

The dimensions of the ACCU are shown in the table below.

*Table 1 Size and weight*

<b>Height</b>	<b>Width</b>	<b>Depth</b>	<b>Weight</b>
293.5 mm	141 mm	60 mm	5 kg

# 3 Function Description

The ACCU consists of a box with:

- A terminal block for incoming AC cables
- Eight-pole main switch (disconnecting device)
- One EMC filter
- Four connection points for cables to the PSUs

## 4 Interfaces

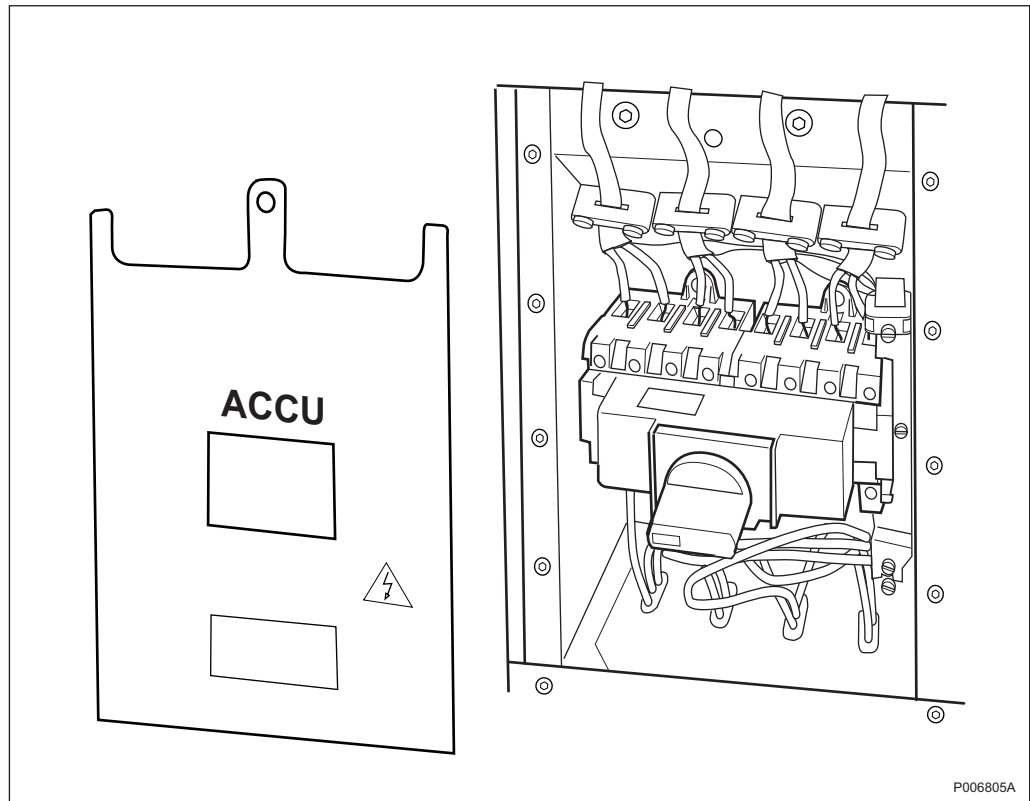

Figure 1 ACCU interfaces

The ACCU has the following interfaces:

- Terminal block for incoming AC mains cables
- Four connection points for outgoing cables to the PSUs

## 4.1 Signal and Power Interfaces

### Input Data

Table 2 Input data

<b>Frequency</b>	45 – 65 Hz
<b>Voltage</b>	90 – 275 V AC
<b>External fuses</b>	4 pcs, max. 16 A
<b>Cable diameter</b>	8.5 – 12.5 mm
<b>Conductor area</b>	1.5 – 2.5 mm <sup>2</sup>
<b>Number of conductors</b>	3 (L, N, PE)

### Output Data

Four cables with connectors according to IEC 320 and for connection to the PSU AC inlet.

## 4.2 Operator Interface

The mains switch on the ACCU that has two states, on (position 1) and off (position 0).



# ACCU-02

AC Connection Unit

## Unit Description

EN/LZT 720 0230 R1A

The AC Connection Unit (ACCU-02) distributes and supervises the incoming AC mains to the units in the RBS cabinet.

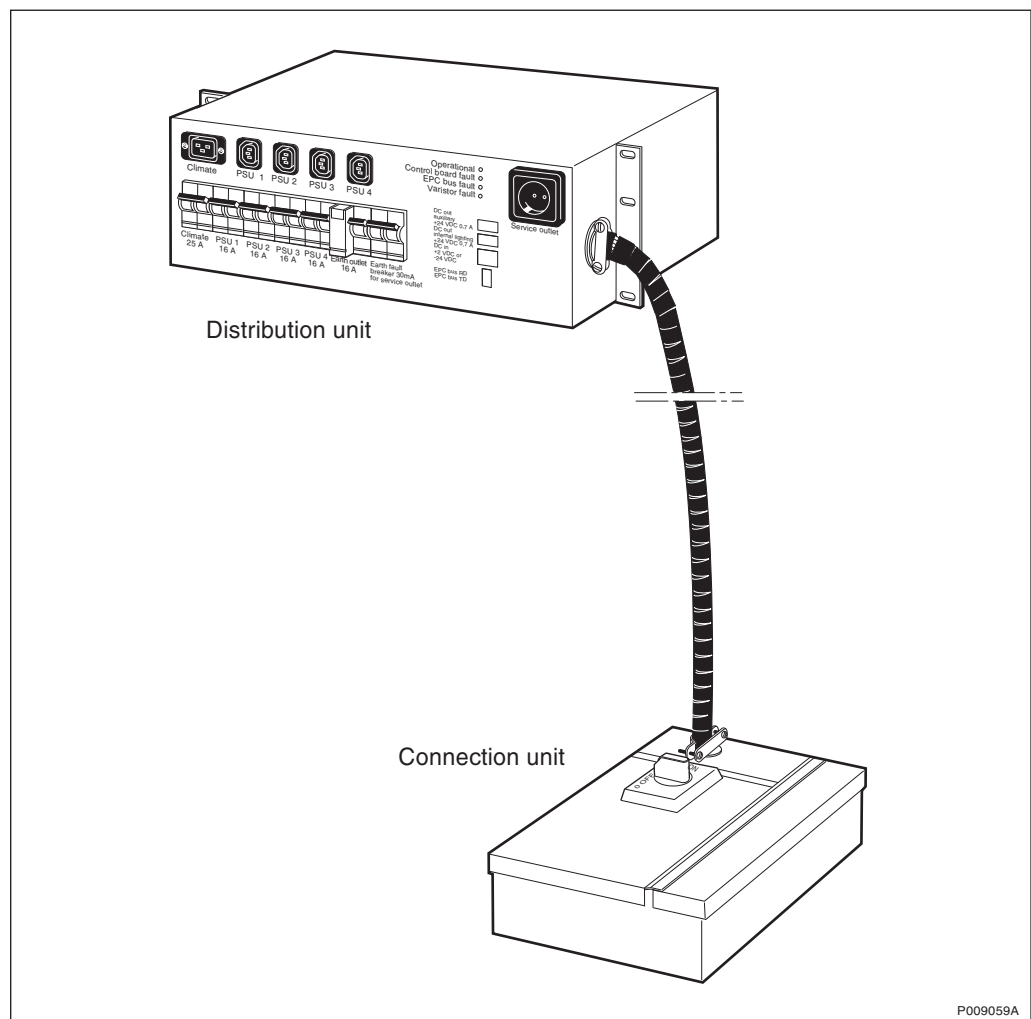

## Contents

<b>1</b>	<b>Product Overview</b>	<b>3</b>
1.1	Main Functions	3
<b>2</b>	<b>Dimensions</b>	<b>3</b>
<b>3</b>	<b>Function Description</b>	<b>3</b>
3.1	Connection Unit	4
3.2	Distribution Unit	4
<b>4</b>	<b>Interfaces</b>	<b>5</b>
4.1	Signal and Power Interfaces	5
4.2	Operator Interface	6

# 1 Product Overview

ACCU-02 distributes and supervises the incoming AC mains to the units in the RBS.

It consists of two units, a Connection Unit and a Distribution Unit. The units are connected together with a power cable and a signal cable.

## 1.1 Main Functions

ACCU-02 has the following main functions:

- Distributes AC power to the PSUs and makes it possible to connect and disconnect the PSUs through the EPC bus.
- Distributes AC power to the Climate Unit.
- Provides EMC filtering and protection against power line disturbances on the incoming AC power.
- Acts as a disconnecting device (Mains Switch).
- Supervises the mains supply and triggers an alarm on undervoltage, fuse fault and worn out overvoltage protectors.
- Provides +24 V DC outputs to lighting in the cabinet and to auxiliary equipment.
- Provides a service outlet for instruments and tools.

## 2 Dimensions

The ACCU has the following dimensions:

*Table 1 Size and weight*

	<b>Height</b>	<b>Width</b>	<b>Depth</b>
<b>Connection unit</b>	93 mm	205 mm	301 mm
<b>Distribution unit</b>	149 mm	435 mm (excluding mounting bracket)	250 mm

## 3 Function Description

The ACCU-02 consists of two units, a Connection Unit and a Distribution Unit.

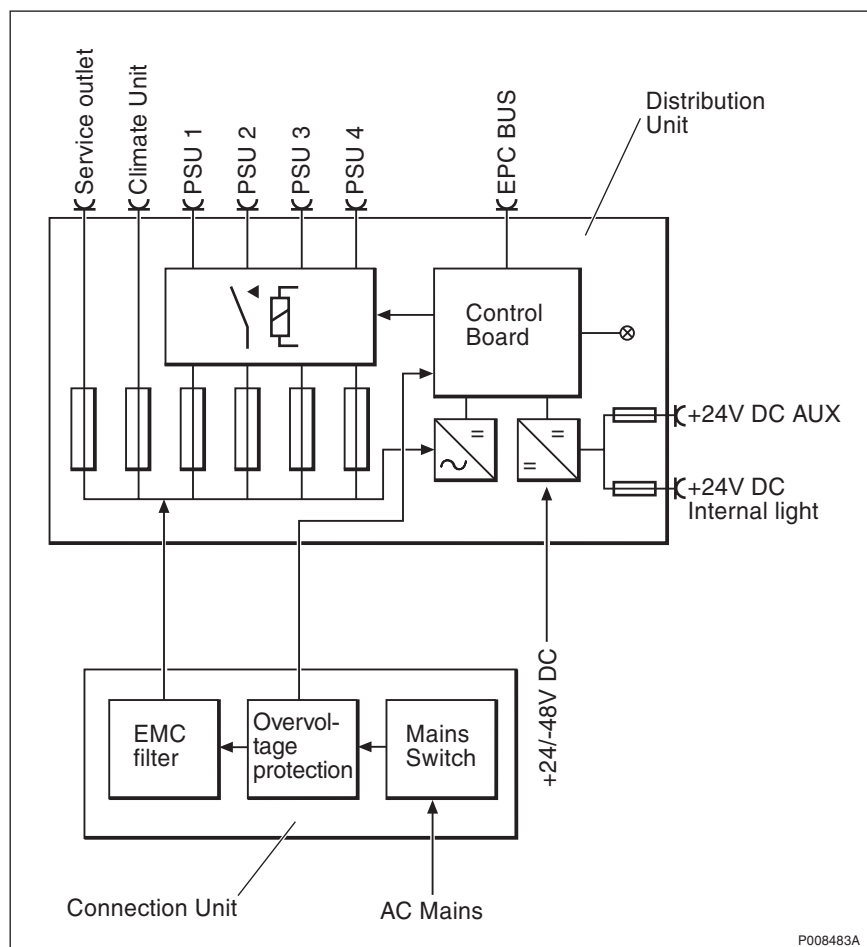

Figure 1 Block diagram of ACCU-02

### 3.1 Connection Unit

The Connection Unit consists of:

- Mains Switch
- Overvoltage protectors
- EMC filter

### 3.2 Distribution Unit

The Distribution Unit consists of:

- Four outlets for PSUs, protected by 16 A circuit breakers
- One outlet for Climate Unit, protected by a 25 A circuit breaker



- One service outlet, protected by a 10 A circuit breaker with earth fault breaker
- Two DC outputs for cabinet lighting and auxiliary equipment, protected by 1 A circuit breakers
- Rectifier for supply of Control Unit
- Voltage Regulator for supply of Control Unit and DC outputs from +24 or -48 V DC
- Relays which provide the possibility to turn off and on the PSU outputs
- Control Unit

## 4 Interfaces

### 4.1 Signal and Power Interfaces

#### Input Data

The input terminals accept supply cables with conductor area of 2.5 – 16 mm<sup>2</sup>. Maximum allowed fuse rating is 63 A per phase.

Table 2 AC supply 50 Hz

<b>Single-phase, four-wire, earthed neutral</b>	200 V AC to 250 V AC
<b>Three-phase star, four-wire <sup>(1)</sup>, earthed neutral</b>	346/200 V AC to 433/250 V AC
	208/120 V AC to 220/127 V AC

(1) It is also possible to supply the ACCU with a three-phase, five-wire system (separate neutral and earth conductors).

Table 3 AC supply 60 Hz

<b>Single-phase, three-wire, earthed mid-point</b>	200/100 V AC to 240/120 V AC
<b>Three-phase star, four-wire <sup>(1)</sup>, earthed neutral</b>	208/120 V AC to 220/127 V AC

(1) It is also possible to supply the ACCU with a three-phase, five-wire system (separate neutral and earth conductors).

Table 4 Priority DC supply to control unit

Option	Voltage Range	Max. Current
+24 V DC	+18 to +32 V DC	1 A <sup>(1)</sup>
-48 V DC	-39 to -60 V DC	0.6 A <sup>(1)</sup>

(1) mA excluding internal lighting.

## Output Data

Table 5 Output voltages

<b>PSU 1 – 4</b>	180 – 275 V AC
<b>Climate Unit</b>	180 – 275 V AC
<b>Service Outlet</b>	Same as input (line to neutral)
<b>Internal lighting +24 V DC</b>	+18 to +32 V DC
<b>Auxiliary +24 V DC</b>	+18 to +32 V DC

**Note:** The DC output voltages require DC input voltage.

Table 6 Output power

<b>PSU 1 – 4</b>	1400 W each
<b>Climate Unit</b>	2300 W
<b>Service Outlet</b>	1500 W (50 Hz), 1200 W (60 Hz)
<b>Internal lighting +24 V DC</b>	1 A
<b>Auxiliary +24 V DC</b>	1 A

## 4.2

### Operator Interface

Table 7 Indicators

Indicator	Colour
Operational	Green
Control board fault	Yellow
EPC bus fault	Yellow
Varistor fault	Yellow

# ADM-01

## Auxiliary Distribution Module

### Description

The ADM distributes DC power through circuit breakers to the TM and to the DC-out 100 W in the RBS 2106.

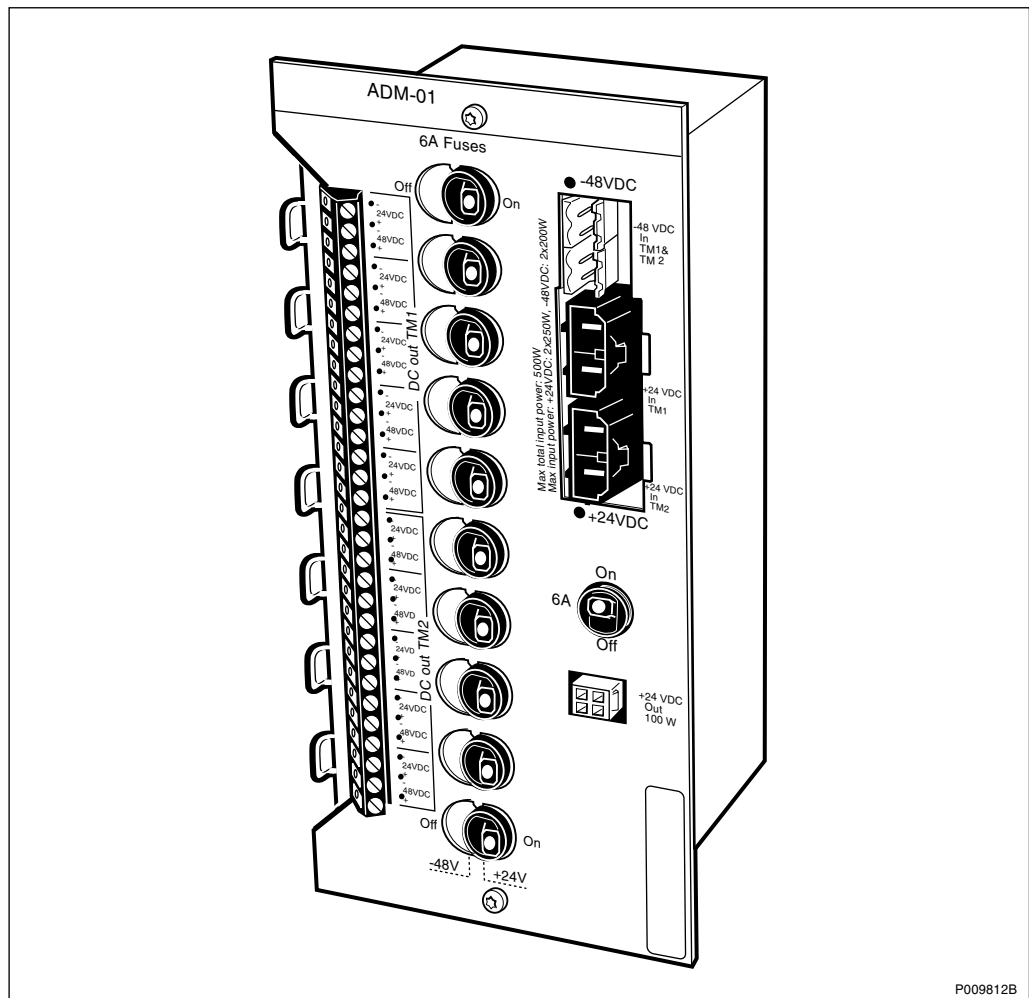

## Contents

<b>1</b>	<b>Product Overview</b>	<b>3</b>
1.1	Main Functions	3
<b>2</b>	<b>Dimensions</b>	<b>3</b>
<b>3</b>	<b>Function Description</b>	<b>4</b>
<b>4</b>	<b>Interface</b>	<b>6</b>
4.1	Signal and Power Interfaces	6
4.2	Operator Interface	7

# 1 Product Overview

The ADM-01 distributes +24 V DC or –48 V DC to the Transport Module (TM) compartment and to the DC out 100 W connection in the DF box.

## 1.1 Main Functions

The ADM-01 has the following main functions:

- Two inputs for +24 V DC
- Two inputs for –48 V DC
- Ten distribution outputs which can be selected for +24 V DC or –48 V DC, protected by 6 A fuses.
- One output for +24 V DC, designated “Out 100 W”, protected by a 6 A fuse.

# 2 Dimensions

This section describes the physical characteristics of the ADM-01.

*Table 1 Size and weight*

<b>Height</b>	<b>Width</b>	<b>Depth</b>	<b>Weight</b>
205 mm	98 mm	80 mm	1 kg

### 3 Function Description

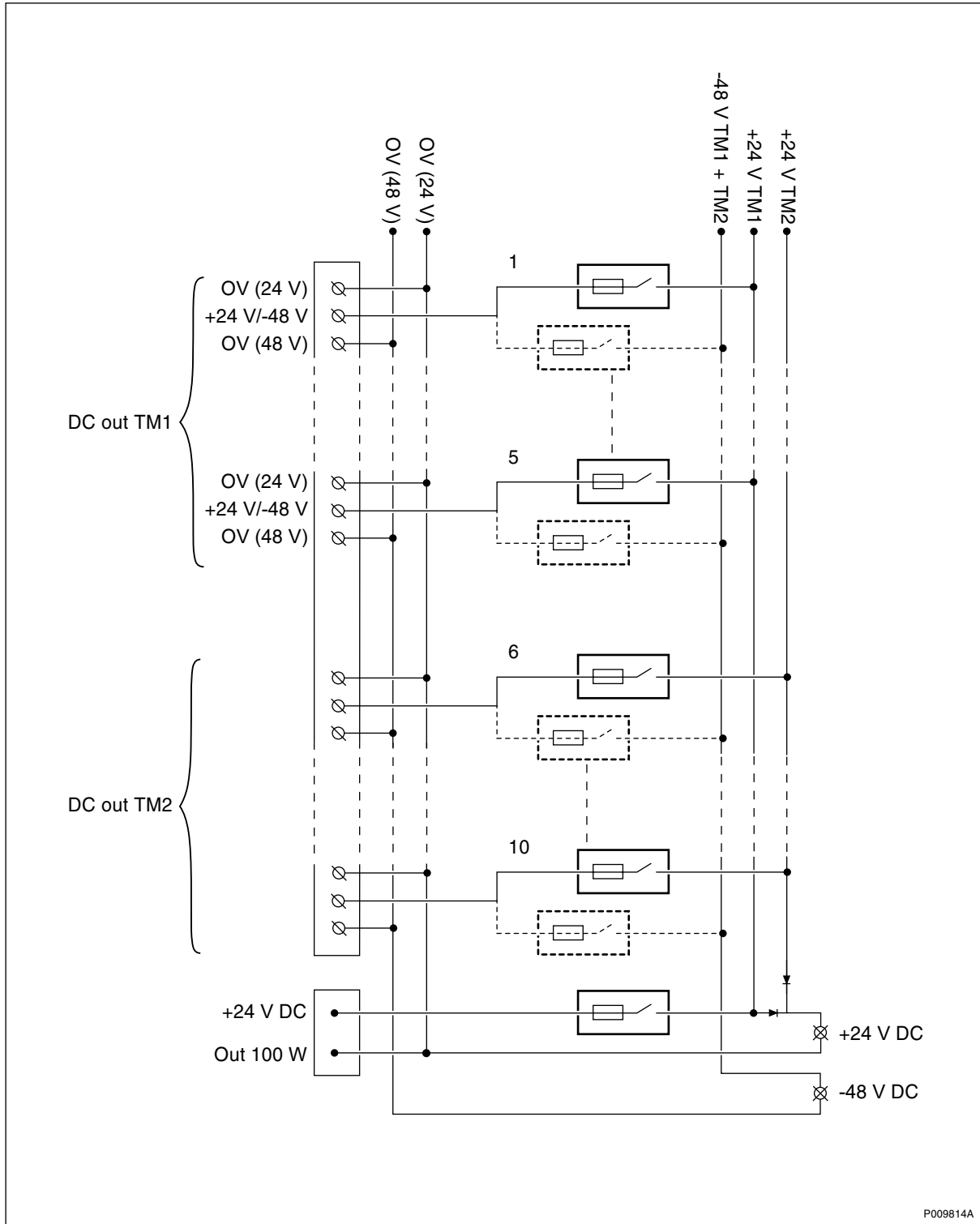

Figure 1 ADM circuit diagram

The ten outputs on the ADM-01 are divided into two groups: DC out TM1 and DC out TM2. The outputs are protected by circuit breakers that function both as fuses and manual disconnect switches.

It is possible to feed the ADM with either +24 V DC or –48 V DC, or both. The feed used is shown by two indicators on the front panel.

One +24 V DC input is connected to the TM1 output group. The second +24 V DC input is connected to the TM2 output group.

The two –48 V DC inputs are connected in parallel to both the TM1 and TM2 groups.

The ADM is delivered with a +24 V DC configuration. By removing the front panel and moving a fuse to the –48 V DC position, it is possible to configure an output for distribution of –48 V DC. Connection of the voltages is shown on the label on the front panel.

The output “Out 100W” is fed –24 V DC from the TM1 input. These outputs are also protected by circuit breakers that function as fuses and manual disconnect switches.

## 4 Interface

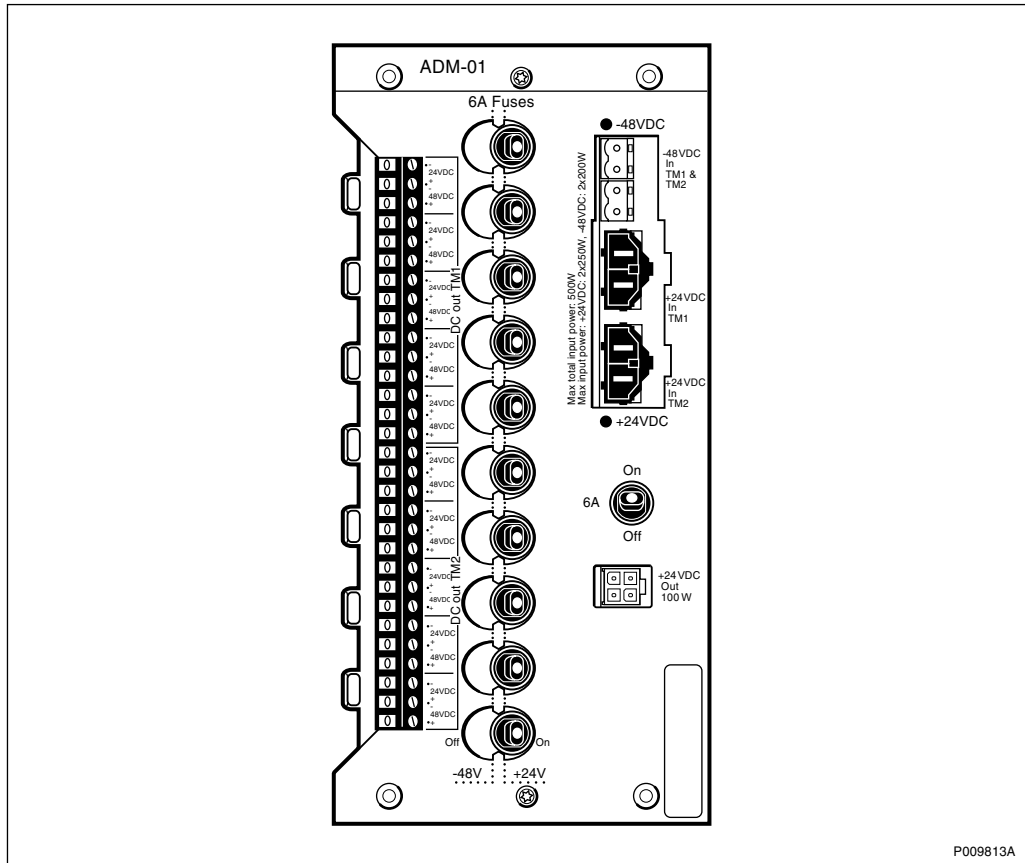

Figure 2 ADM interfaces

### 4.1 Signal and Power Interfaces

#### Input Data

Table 2 Input voltage characteristics

Characteristics	Nominal voltage:	
	+24 V DC	-48 V DC
Normal voltage	+20.0 to +29.0 V DC	-39.0 to -60.0 V DC
Non-destructive	0 to 32 V DC	0 to -70 V DC
Input power	2 x 250 W	2 x 200 W
Input fuse rating	15 A	10 A
Connectors	2 x RPV 403 099/102	2 x RPV 262 001/2



*Table 3 Input power*

Nominal voltages	Input power	Input fuse rating
+24 V DC	2 x 250 W	2 x 15 A
-48 V DC	2 x 200 W	2 x 10 A
+24 and -48 V DC	250 + 200 W	15 A and 10 A

**Note:** The total input power to the ADM must not exceed 500 W.

## Output Data

*Table 4 Output connections*

Output	Connection	Fuse
DC out TM1, pos 1 – pos 5	Screw terminals 0.5 – 2.5 mm <sup>2</sup>	6 A
DC out TM2, pos 1 – pos 5	Screw terminals 0.5 – 2.5 mm <sup>2</sup>	6 A
+24 V DC Out	RPV 403 109/604	6 A

## 4.2

### Operator Interface

Output power can be manually switched off using the eleven circuit breakers on the front panel.

*Table 5 Indicators*

Indicator	Colour
+24 V DC present	Green
-48 V DC present	Green

Ericsson AB  
SE-164 80 Stockholm  
Sweden

[implementation.GSMsupport@era.ericsson.se](mailto:implementation.GSMsupport@era.ericsson.se)

Due to continued progress in methodology, design and manufacturing,  
the contents of this document are subject to change without notice.

© Ericsson AB

# ASU

Antenna Sharing Unit

## Unit Description

EN/LZT 720 0232 R1A

The Antenna Sharing Unit (ASU) is used as a part of co-siting, where a cabinet, operating on another standard, shares antennas with a GSM cabinet in the same sector.

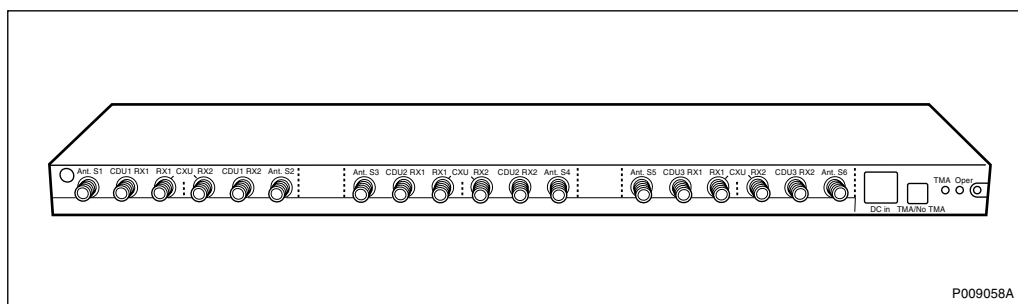

## Contents

<b>1</b>	<b>Product Overview</b>	<b>3</b>
1.1	Main Functions	3
<b>2</b>	<b>Dimensions</b>	<b>3</b>
<b>3</b>	<b>Power Consumption and Heat Generation</b>	<b>3</b>
<b>4</b>	<b>Function Description</b>	<b>3</b>
4.1	RX Signal Path	4
4.2	Cable Path and Supervision	5
<b>5</b>	<b>Interfaces</b>	<b>5</b>
5.1	Signal and Power Interfaces	5
5.2	Operator Interface	7

# 1 Product Overview

## 1.1 Main Functions

Antenna sharing is part of co-siting, that is, using a cabinet operating on another standard together with a GSM cabinet in the same sector. The ASU allows a TDMA (or other) cabinet and a GSM cabinet to share RX antennas. It does this by sharing the RX signals between both cabinets.

The ASU is a broadband product, which means that it covers 800 –1910 MHz.

# 2 Dimensions

*Table 1 Size and weight*

Height	Width	Depth	Weight
22 mm	437.5 mm	120 mm <sup>(1)</sup>	2 kg

*(1) The ASU protrudes 40 mm from the rack (including the front panel).*

# 3 Power Consumption and Heat Generation

*Table 2 Power consumption and heat generation*

Max. power consumption	Max. heat generation
2 W	2 W

# 4 Function Description

The general function of the ASU is to take a portion of the RX signal and send it to the co-sited RBS.

The ASU also switches the attenuation according to whether or not a TMA is used. It also indicates the attenuation state via an indicator.

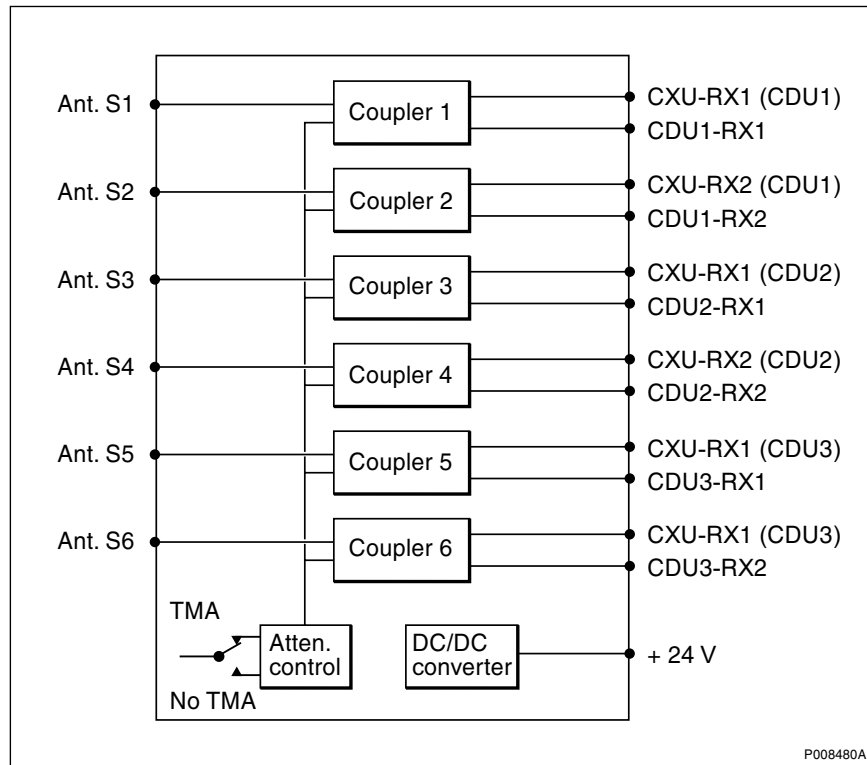

Figure 1 ASU block diagram

#### 4.1 RX Signal Path

The RX signal path is fed from the antennas through the feeders to the Antenna Reference Point (ARP). The signal is then filtered and amplified in the CDU. From the RX output of the CDU, the signal is fed to the ASU where a small portion of the signal is fed to the RX input of the co-sited RBS. This is shown in the figure below.

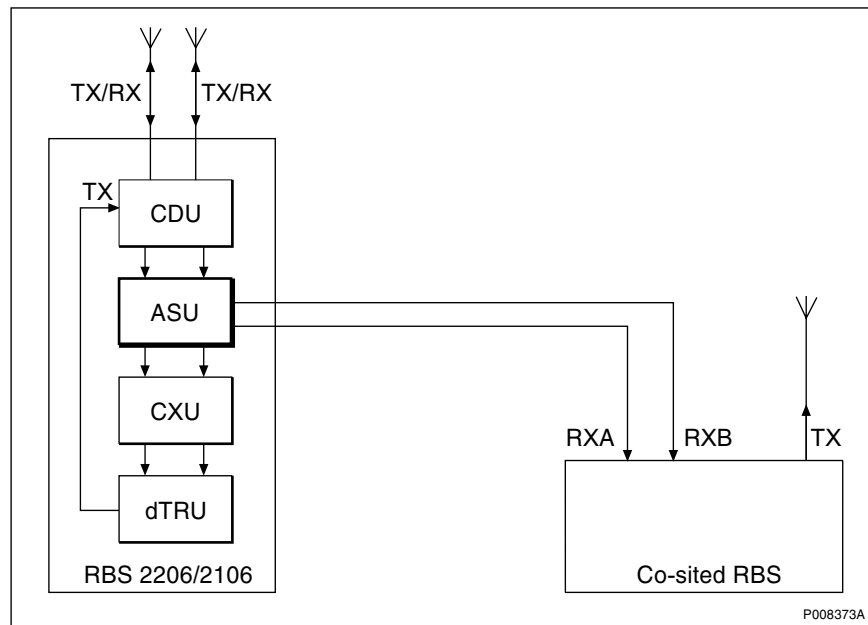

Figure 2 RX signal path

## 4.2 Cable Path and Supervision

The RF cables between the ASU and the co-sited RBSs can be supervised by the TMA support function in the TDMA cabinet.

## 5 Interfaces

### 5.1 Signal and Power Interfaces

#### Connectors

The ASU has the following connectors:

- Six input ports for RX signals from the CDU
- Six output ports for RX signals to the CXU
- Six output ports for RX signals to the co-sited RBS
- Power supply connector

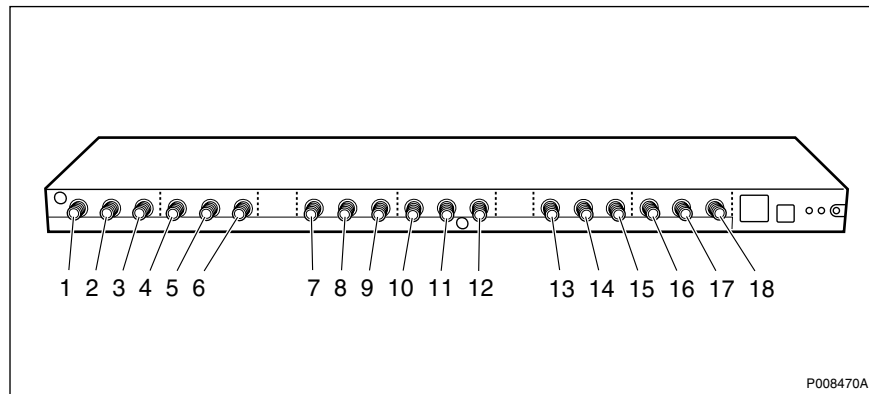

Figure 3 Connection ports

Table 3 Connection ports

Pos.	ASU label	Connects to	Type of connector
1	Ant.S1	Antenna sharing connectors	QMA
2	CDU1 RX1	CDU 1, port RX1	QMA
3	RX1	CXU, port 3	QMA
4	RX2	CXU, port 4	QMA
5	CDU1 RX2	CDU 1, port RX2	QMA
6	Ant.S2	Antenna sharing connectors	QMA
7	Ant.S3	Antenna sharing connectors	QMA
8	CDU2 RX1	CDU2, port RX1	QMA
9	RX1	CXU port 9	QMA
10	RX2	CXU port 10	QMA
11	CDU2 RX2	CDU 2, port RX2	QMA
12	Ant.S4	Antenna sharing connectors	QMA
13	Ant.S5	Antenna sharing connectors	QMA
14	CDU3 RX1	CDU 3, port RX1	QMA
15	RX1	CXU port 15	QMA
16	RX2	CXU port 16	QMA
17	CDU3 RX2	CDU 3, port RX2	QMA
18	Ant.S6	Antenna sharing connectors	QMA



## 5.2 Operator Interface

There is one switch on the front panel to set the internal attenuators for TMA or no TMA.

There are two indicators on the front indicating the status of the ASU.

*Table 4 Indicators*

<b>Indicator</b>	<b>Colour</b>
Operational	Green
TMA	Yellow



# BFU-21

Battery Fuse Unit

## Unit Description

EN/LZT 720 0234 R1A

The Battery Fuse Unit (BFU) monitors and controls the battery. It cuts off the load (the RBS) at low battery voltage, when the temperature of the battery is too high or if there is a short circuit between the distribution cables.

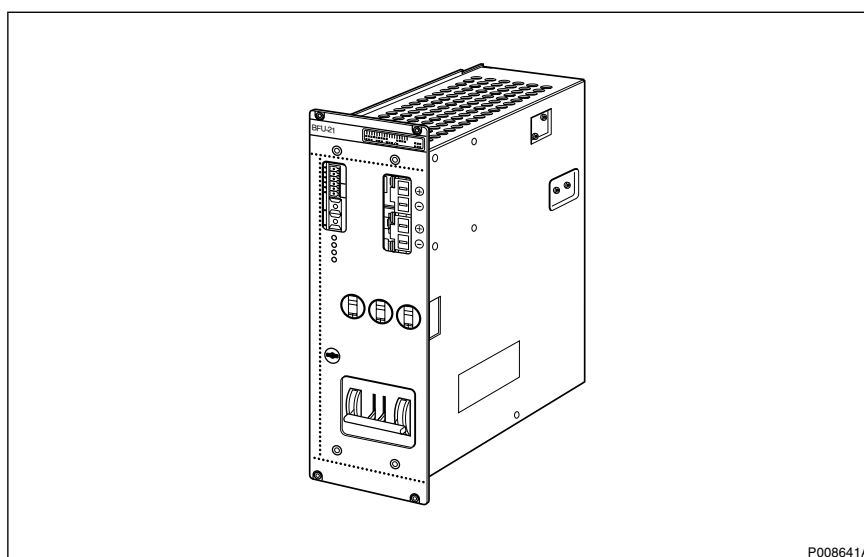

## Contents

<b>1</b>	<b>Product Overview</b>	<b>3</b>
1.1	Main Functions	3
<b>2</b>	<b>Dimensions</b>	<b>3</b>
<b>3</b>	<b>Function Description</b>	<b>4</b>
3.1	Contactors	4
3.2	Circuit Breaker	5
3.3	Shunt	5
3.4	TM and EC Supply	5
<b>4</b>	<b>Interfaces</b>	<b>5</b>
4.1	Signal and Power Interfaces	5
4.2	Operator Interface	6

# 1 Product Overview

The BFU-21 supplies battery back-up system voltage to the RBS and disconnects the battery when it has reached its lower discharge limit. The contactor can disconnect and connect the battery with a control signal from the Supervision Module (SM).

## 1.1 Main Functions

The BFU has the following functions:

- Supplies priority power to transmission equipment. Power to transmission equipment can be distributed even if a battery is not present. The relay can select the power source with a control signal from the SM.
- Supplies priority power to the EC output. The EC output is protected from reverse currents by a diode. Power to the EC output can be distributed even if a battery is not present. The relay can select the power source with a control signal from the SM.
- Communicates on the EPC bus (opto cable) with the DXU. If the EPC bus is not present, the BFU operates at its default values. The battery voltage, current and temperature are monitored and alarms are sent on the EPC bus.
- Disconnects the batteries, if the current is too low or the temperature is too high. Reconnects the batteries when the temperature returns to normal.
- Sends a "Battery temperature sensor fault" message to the DXU when the battery temperature is faulty.
- Disconnects battery back-up manually or by control signals on the EPC bus.
- The SM provides self-detection of internal faults and stores them in non-volatile memory.

## 2 Dimensions

The BFU-21 has the following dimensions:

*Table 1 Size and weight*

Height	Width	Depth	Weight
267 mm	82 mm	226 mm	5 kg

### 3 Function Description

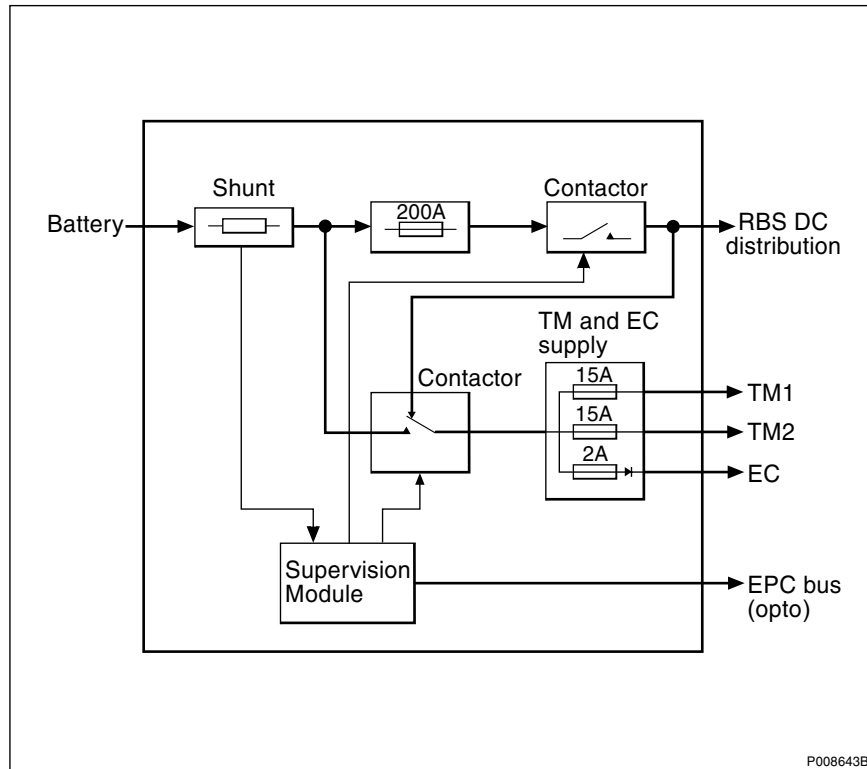

Figure 1 Block diagram of BFU-21

The BFU consists of the following blocks:

- Contactors
- Circuit breakers
- Shunt
- TM and EC supply
- Supervision module

#### 3.1 Contactor

The Contactor is used to disconnect the batteries from the system. The Supervision Module controls the Contactor.

### **3.2 Circuit Breaker**

The circuit breaker disconnects the batteries if the current becomes too high. It can also be manually operated on the front of the BFU to connect or disconnect the batteries from the DC distribution.

### **3.3 Shunt**

The shunt is used to sense the input current. The SM senses the value, which is used for control of the BFU.

### **3.4 TM and EC Supply**

There are two TM outputs for supply of transmission equipment and one EC output for priority supply of the Control Board in the ACCU.

## **4 Interfaces**

The BFU has the following interfaces:

- Battery
- RBS DC distribution
- TM1 supply 15 A
- TM2 supply 15 A
- EC supply 2 A
- EPC bus

### **4.1 Signal and Power Interfaces**

The tables below show input data and output current.

Table 2 *Input data*

<b>Nominal input voltage</b>	+24 V DC negative ground
<b>Permitted variation input voltage</b>	+18.0 to +29.0 V DC
<b>Non-destruction input voltage</b>	0.0 to +32.0 V DC
<b>Power</b>	4800 W
<b>Nominal input current</b>	185 A
<b>Maximum input current</b>	205 A
<b>Maximum current ripple (20 Hz - 20 kHz)</b>	24 Arms

Table 3 *Output currents*

<b>RBS DC distribution (nominal)</b>	160 A
<b>RBS DC distribution (maximum)</b>	180 A (during 3 hrs)
<b>TM1 supply</b>	12 A
<b>TM2 supply</b>	12 A
<b>EC supply</b>	1.5 A

## 4.2 Operator Interface

On the front panel there are four indicators (*see table below*) and four switches.

Table 4 *Indicators*

<b>Indicator</b>	<b>Colour</b>
Fault	Red
Operational	Green
EPC bus fault	Yellow
Battery disconnected	Yellow



**Switches**

- Battery Disconnect - on/off
- DC out 1 - on/off
- DC out 2 - on/off
- EC - on/off



# BFU-22

Battery Fuse Unit

## Unit Description

EN/LZT 720 0276 R1A

The Battery Fuse Unit (BFU) monitors and controls the battery. It cuts off the load (the RBS) at low battery voltage, when the temperature of the battery is too high or if there is a short circuit between the distribution cables.

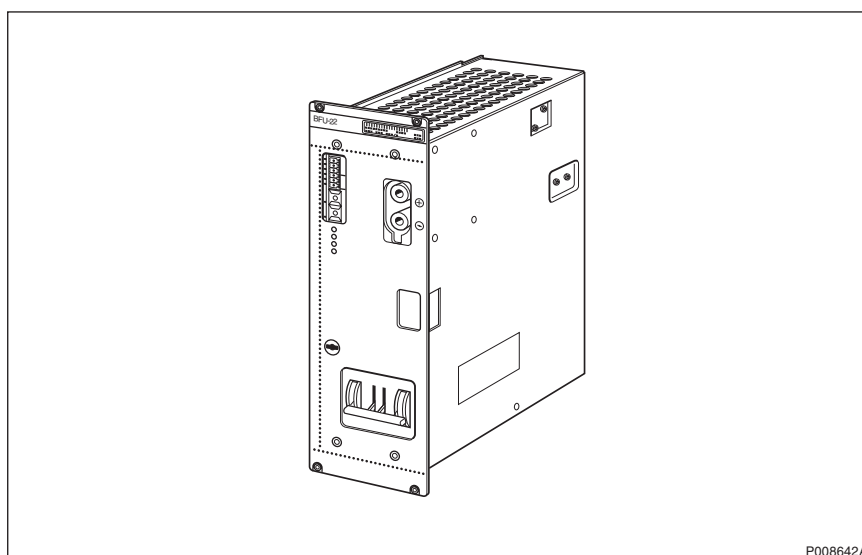

## Contents

<b>1</b>	<b>Product Overview</b>	<b>3</b>
1.1	Main Functions	3
<b>2</b>	<b>Dimensions</b>	<b>3</b>
<b>3</b>	<b>Function Description</b>	<b>4</b>
3.1	Contactator	4
3.2	Circuit Breaker	5
3.3	Shunt	5
3.4	TM Supply	5
<b>4</b>	<b>Interfaces</b>	<b>5</b>
4.1	Signal and Power Interfaces	5
4.2	Operator Interface	6

# 1 Product Overview

The BFU-22 supplies battery back-up system voltage to the RBS and disconnects the battery when it has reached its lower discharge limit. The contactor can disconnect and connect the battery with a control signal from the Supervision Module (SM).

## 1.1 Main Functions

The BFU can supply priority power to transmission equipment. Power to transmission equipment can be distributed even if a battery is not present. The relay can select the power source with a control signal from the SM.

The BFU communicates on the EPC bus (opto cable) with the DXU. If the EPC bus is not present, the BFU operates at its default values. The battery voltage, current and temperature are monitored and alarms are sent on the EPC bus.

The BFU disconnects the battery, if the current is too low or the temperature is too high. When the temperature returns to normal, the battery is reconnected.

If the battery temperature sensor is faulty, a "Battery temperature sensor fault" message is sent to the DXU.

Battery back-up can also be manually disconnected or disconnected by control signals on the EPC bus.

The SM provides self-detection of internal faults and stores them in non-volatile memory.

# 2 Dimensions

*Table 1 Size and weight*

Height	Width	Depth	Weight
267 mm	82 mm	226 mm	5 kg

### 3 Function Description

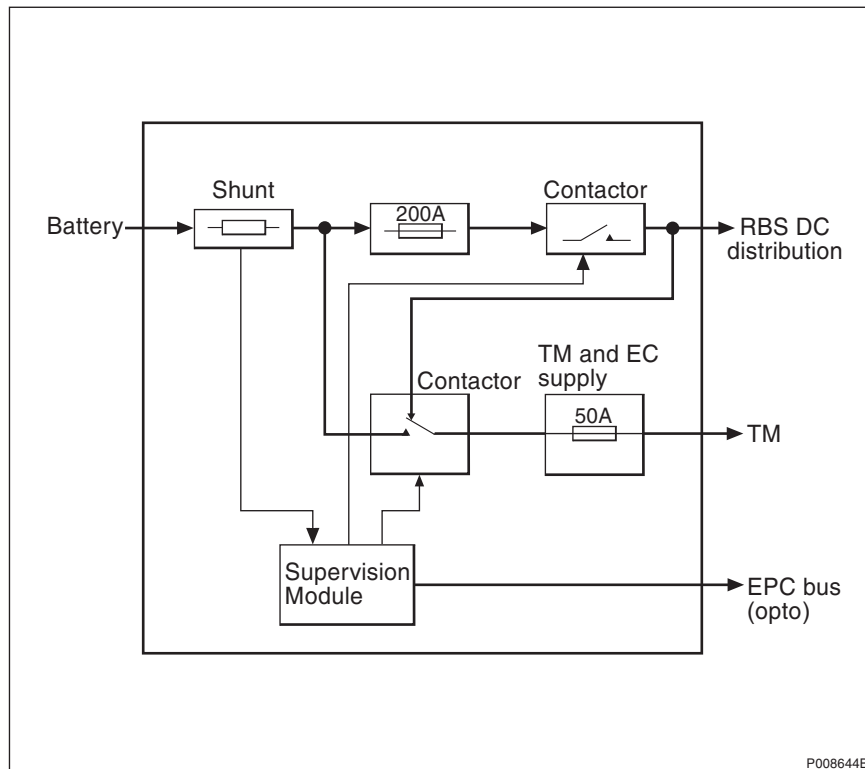

Figure 1 Block diagram of BFU-22

The BFU consists of the following blocks:

- Contactors
- Circuit breakers
- Shunt
- TM and EC supply
- Supervision module

#### 3.1 Contactor

The contactor is used to disconnect the batteries from the system. The SM controls the contactor.

### 3.2 Circuit Breaker

The circuit breaker disconnects the batteries if the current becomes too high. It can also be manually operated on the front of the BFU to connect or disconnect the batteries from the DC distribution.

### 3.3 Shunt

The shunt is used to sense the input current. The SM senses the value, which is used for control of the BFU.

### 3.4 TM Supply

One high-power TM output exists for supply of transmission equipment.

## 4 Interfaces

The BFU has the following interfaces:

- Battery
- RBS DC distribution
- TM supply 50 A
- EPC bus

### 4.1 Signal and Power Interfaces

The tables below show input data and output current.

*Table 2 Input data*

<b>Nominal input voltage</b>	+24 V DC negative ground
<b>Permitted variation input voltage</b>	+18.0 to +29.0 V DC
<b>Non-destruction input voltage</b>	0.0 to +32.0 V DC
<b>Power</b>	4800 W
<b>Nominal input current</b>	200 A
<b>Maximum input current</b>	220 A
<b>Maximum current ripple (20 Hz - 20 kHz)</b>	24 Arms

*Table 3 Output currents*

<b>RBS DC distribution (nominal)</b>	160 A
<b>RBS DC distribution (maximum)</b>	180 A (during 3 hrs)
<b>TM supply</b>	40 A

## 4.2 Operator Interface

### Indicators

*Table 4 Indicators*

<b>Indicator</b>	<b>Colour</b>
Fault	Red
Operational	Green
EPC bus fault	Yellow
Battery disconnected	Yellow

### Switches

- Battery Disconnect - on/off
- DC out - on/off



# CDU-F

Combining and Distribution Unit

## Product Description

EN/LZT 720 0237 R1A

The Combining and Distribution Unit (CDU) is the interface between the transceivers (TRUs) and the antenna system.

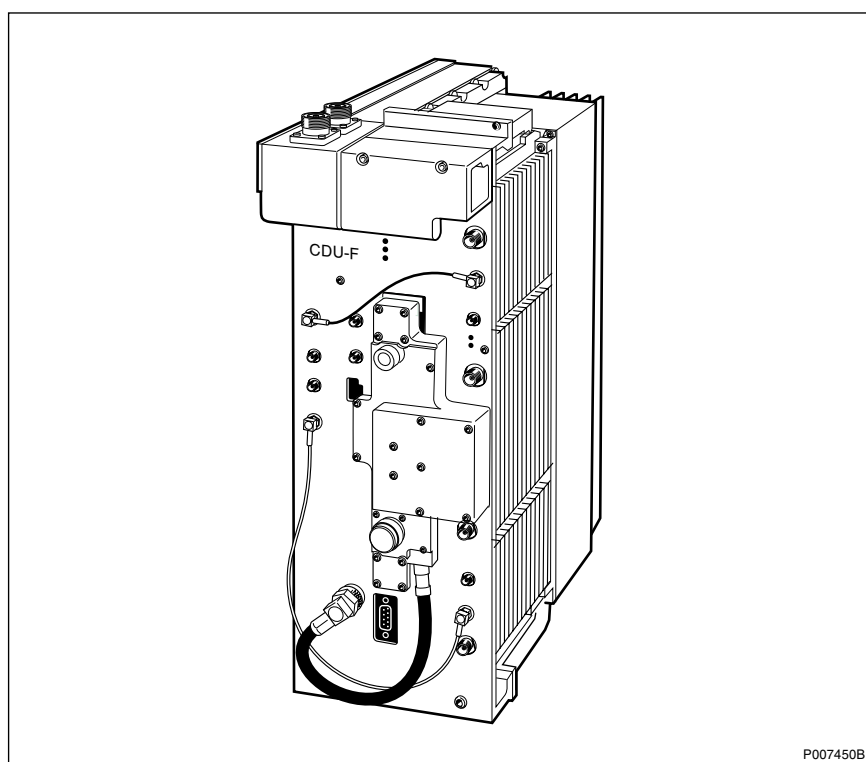

## Contents

<b>1</b>	<b>Product Overview</b>	<b>3</b>
1.1	Main Functions	3
1.2	Variants	3
<b>2</b>	<b>Dimensions</b>	<b>3</b>
<b>3</b>	<b>Power Consumption and Heat Generation</b>	<b>4</b>
<b>4</b>	<b>Function Description</b>	<b>4</b>
4.1	TX part description	5
4.2	RX Part Description	5
<b>5</b>	<b>Interfaces</b>	<b>6</b>

# 1 Product Overview

A range of CDU types have been developed to support different configurations.

The choice depends on operator's initial and future requirements. The following factors should be taken into consideration when selecting CDU type:

- Initial cost
- Capacity and coverage requirements
- Number of antennas.

CDU-F handles one to six dTRUs. CDU-F is used in high capacity, medium output power configurations. It supports both synthesiser and baseband frequency hopping.

## 1.1 Main Functions

CDU-F has the following main functions:

- Combines four TX signals to one antenna.
- Automatically tuned cavity combiners operated by step motors
- Supports baseband hopping
- Provides simultaneous transmission and reception on one antenna
- Amplifies two RX signals from two antennas for further distribution in the CXU

## 1.2 Variants

CDU-F is available for GSM 900 and GSM 1800.

# 2 Dimensions

This section describes the physical characteristics of CDU-G.

Table 1 CDU-F Size and weight

Height	Width	Depth	Weight
400 mm (9 HE x 44.45 mm)	142 mm (28 TE x 5.08 mm)	239 + 90 mm <sup>1)</sup>	15 kg

<sup>1)</sup> The upper part protrudes 90 mm

### 3 Power Consumption and Heat Generation

Figures for power consumption and heat generation are shown in the table below.

Table 2 Power consumption and heat generation

Max power consumption	Max heat generation
70 W	70 W

### 4 Function Description

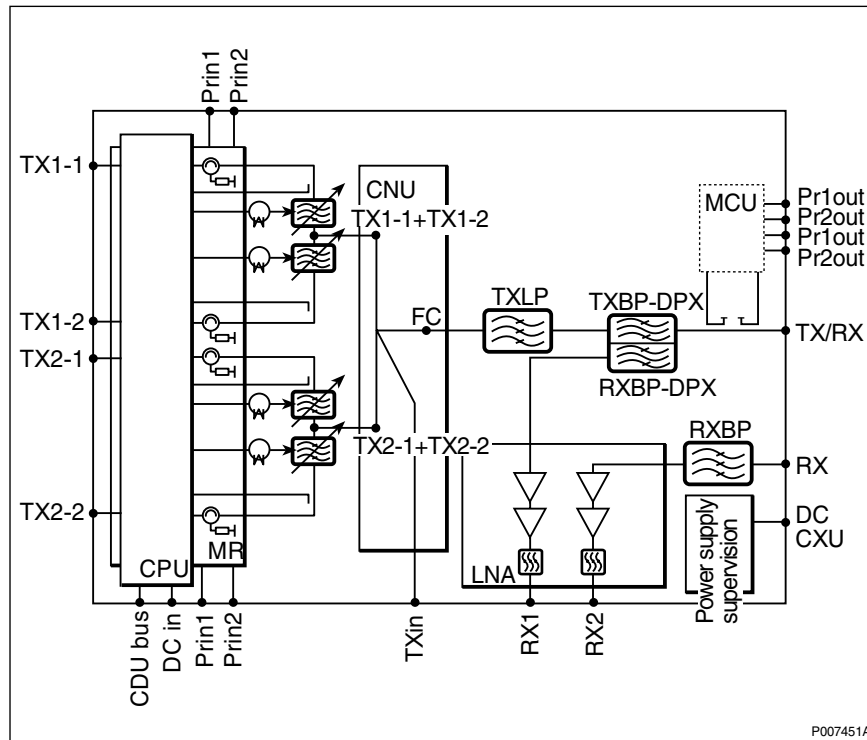

Figure 1 Block diagram of CDU-F

## 4.1 TX part description

CDU-F has four filter cavities grouped internally two and two. The two filters form a combiner for two TX signals and can be combined with a Combining Network Unit (CNU) to a combiner for four signals, or connected to another CDU-F to form a combining network for six signals.

The combined signals are fed through a lowpass TX filter to a duplex filter. The duplex filter allows the use of a single antenna both for transmitting and receiving. The duplex filter is connected directly to the antenna connector on top of the CDU.

All necessary connections for the TX combining network are done on the front of the CDU with the CNU.

Tuning the filter cavities is controlled by the Measurement Receiver (MR) and the Central Processor Unit (CPU).

A small part of the output and reflected power is distributed by the Measurement Coupler Unit (MCU) to four outputs. The signals are then connected to the MR in the same CDU-F, or the MR in another CDU-F, depending on the configuration.

The MR measures the input signal to the filter combiners and also the outgoing signal to the antenna. These two signals are used in the CPU to control the stepper motors, one for each filter cavity. Moving parts in the filter cavity, tune the combiner to the correct frequency.

## 4.2 RX Part Description

The duplex filter filters out the RX signal arriving to the antenna. This filtered signal is amplified in a two-stage low noise amplifier and then filtered in a lowpass filter.

CDU-F also has an extra RX chain for diversity reception. This extra RX chain is similar to the duplex RX chain.

Distribution of RX signals is performed in the Configuration Switching Unit (CXU).

## 5 Interfaces

The external interfaces of CDU-F are listed in the table below.

*Table 3 Interfaces on CDU-F*

<b>Interface</b>	<b>Type of connector</b>
TX/RX, RX	7-16 female
RX1, RX2	QMA female
TX1 – TX4	TNC female
Pf in1, PF in2, Pr in1, Pr in2	SMA female
Pf out1, Pf out2, Pr out1, Pr out2	SMA female
FC	N female
CDU bus	9-pin male, D-sub
DC in	2-pin male Molex Mini-Fit

CDU-F has the following indicators on the front panel.

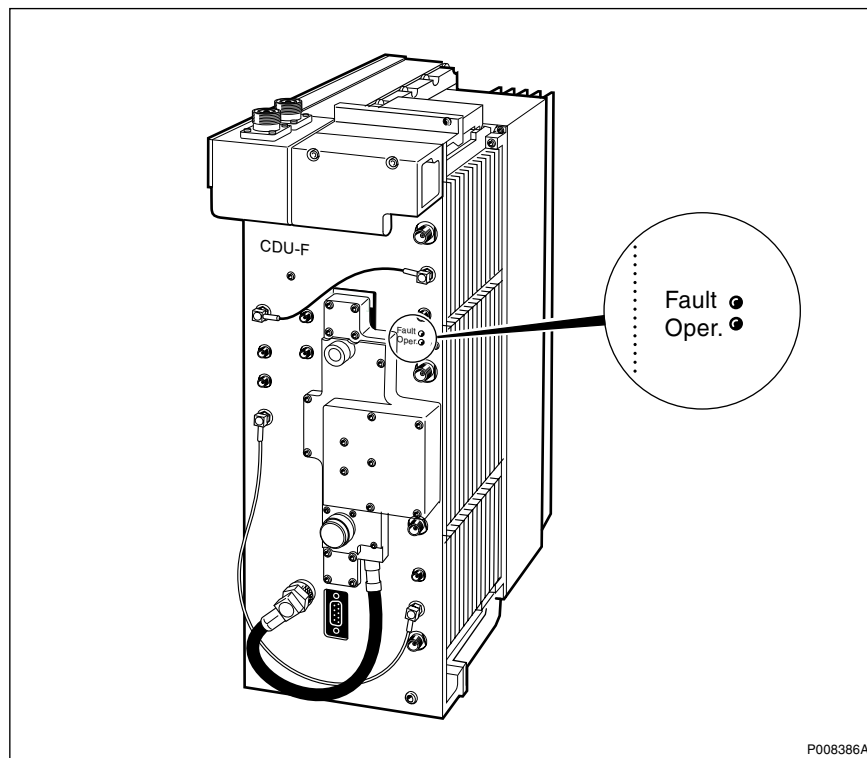

*Figure 2 Indicators on CDU-F*

*Table 4 Indicators on CDU-F*

<b>Colour, Label</b>	<b>Mode</b>	<b>Indication</b>
Red, Fault	Off	No fault is localised in the unit
	On	One or more faults are localised in the unit
	Flashing	The unit has detected lost communication to a superior unit.
Green, Operational	Off	The unit is not operational
		The unit is operational





# CDU-G

Combining and Distribution Unit

## Product Description

EN/LZT 720 0236 R1A

The Combining and Distribution Unit (CDU) is the interface between the transceivers (TRUs) and the antenna system.

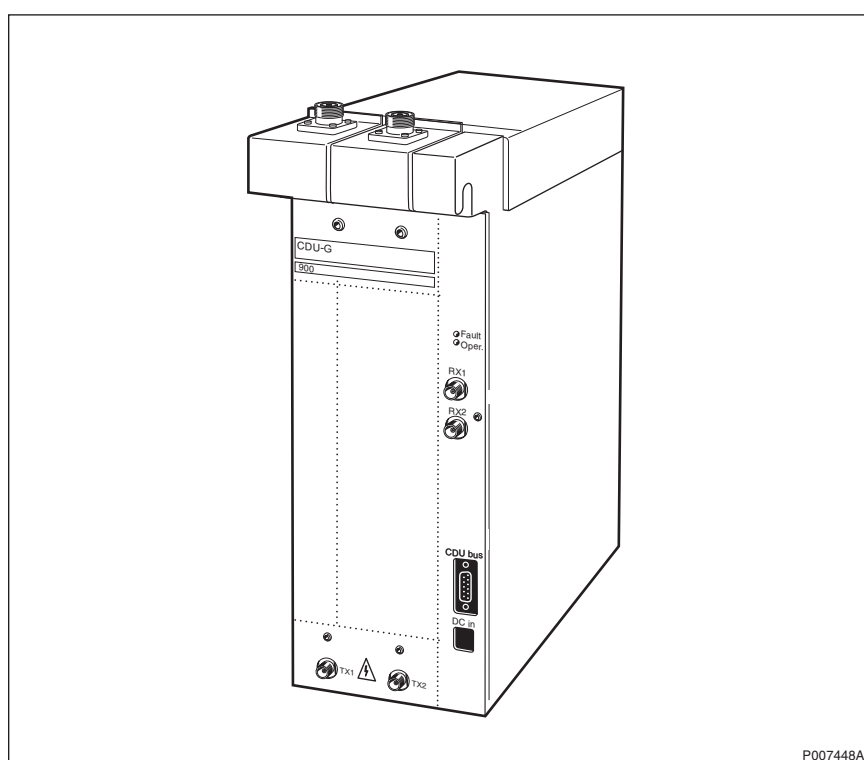

## Contents

<b>1</b>	<b>Product Overview</b>	<b>3</b>
1.1	Main Functions	3
1.2	Variants	3
<b>2</b>	<b>Dimensions</b>	<b>3</b>
<b>3</b>	<b>Power Consumption and Heat Generation</b>	<b>4</b>
<b>4</b>	<b>Function Description</b>	<b>4</b>
4.1	TX part description	4
4.2	RX Part Description	5
<b>5</b>	<b>Interfaces</b>	<b>5</b>

# 1 Product Overview

A range of CDU types have been developed to support different configurations. The choice depends on operator's initial and future requirements. The following factors should be taken into consideration when selecting CDU type:

- Initial cost
- Capacity and coverage requirements
- Number of antennas.

CDU-G handles one or two dTRUs. Connected to one dTRU, it provides a low capacity, high output power configuration. Connected to two dTRUs it provides a high capacity, low output power configuration. CDU-G supports both synthesiser and baseband frequency hopping.

## 1.1 Main Functions

CDU-G has the following main functions:

- Enables connection of two TX signals to two antennas. The TX signal can be two combined signals or two uncombined signals. CDU-G has no combining circuits; the combining takes place outside the CDU.
- Provides simultaneous transmission and reception on each antenna
- Amplifies two RX signals from two antennas for further distribution in the CXU

## 1.2 Variants

CDU-G is available for GSM 800, GSM 900, GSM 1800 and GSM 1900.

# 2 Dimensions

This section describes the physical characteristics of CDU-G.

Table 1 CDU Size and weight

Height	Width	Depth	Weight
400 mm (9 HE x 44.45 mm)	142 mm (28 TE x 5.08 mm)	239 + 90 mm <sup>1)</sup>	15 kg

<sup>1)</sup> The upper part protrudes 90 mm

### 3 Power Consumption and Heat Generation

Table 2 Power consumption and heat generation

Max power consumption	Max heat generation
30 W	30 W

### 4 Function Description

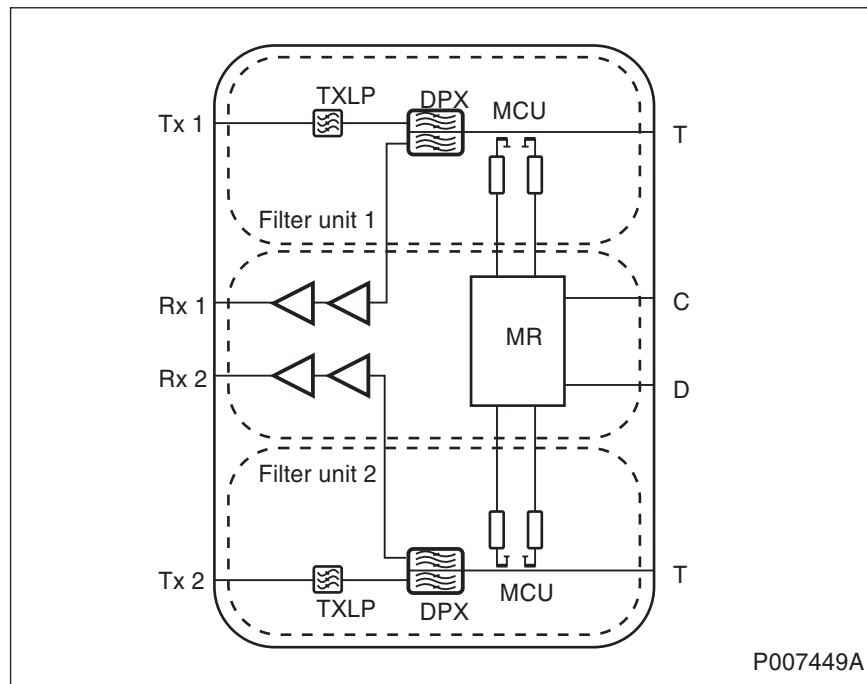

Figure 1 Block diagram of CDU-G

#### 4.1 TX part description

CDU-G consists of two identical TX chains. These are the top and bottom parts encircled by dotted lines in the diagram above.

The TX part contains a lowpass filter and a duplex filter. The lowpass filter (TXLP) secures the required reverse isolation. It also reduces spurious signals from the transmitter on frequencies higher than the TX band. The duplex filter (DPX) enables the use of a single antenna for both transmitting and receiving.

There is a Measurement Coupler Unit (MCU) between the DPX and antenna connector. The MCU samples forward and reflected signals and distributes them to the Measurement Receiver (MR) for antenna return loss monitoring.

## 4.2 RX Part Description

CDU-G consists of two identical RX chains. These are the middle part encircled by a dotted line in the above diagram.

The RX part consists of a filter and a low noise amplifier (LNA). The receiver filter is included in the duplex filter.

Distribution of RX signals is performed in the Configuration Switching Unit (CXU).

## 5 Interfaces

The external interfaces of CDU-G are listed in the table below.

*Table 3 Interfaces on CDU-G*

<b>Interface</b>	<b>Type of connector</b>
TX/RX1, TX/RX2	7-16 female
RX1, RX2	QMA female
TX1, TX2	TNC female
CDU bus	9-pin male, D-sub
DC in	2-pin male Molex Mini-Fit

CDU-G has the following indicators on the front panel.

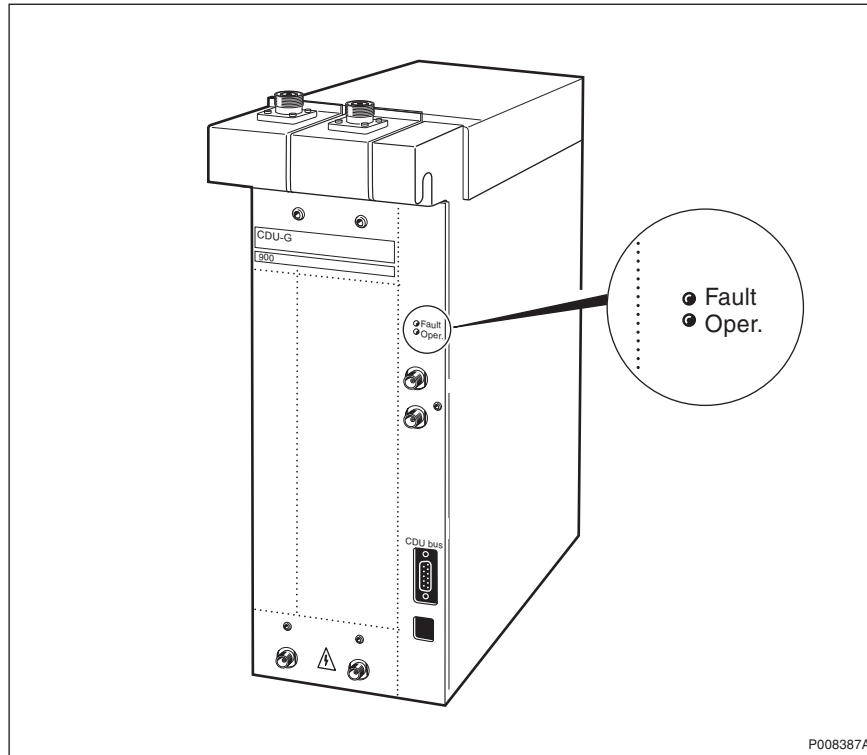

Figure 2 CDU-G indicators

Table 4 CDU-G indicators

Colour, Label	Mode	Indicates
Red, Fault	Off	No fault is localised in the unit
	On	One or more faults are localised in the unit
	Flashing	The unit has detected lost communication to a superior unit.
Green, Operational	Off	The unit is not operational
		The unit is operational

# Combined Climate Unit

## Climate Unit for RBS 2106

### Description

The climate unit maintains the internal environment regarding temperature and humidity within allowed ranges for the units inside the cabinet. The climate unit is mounted in the door of the cabinet.

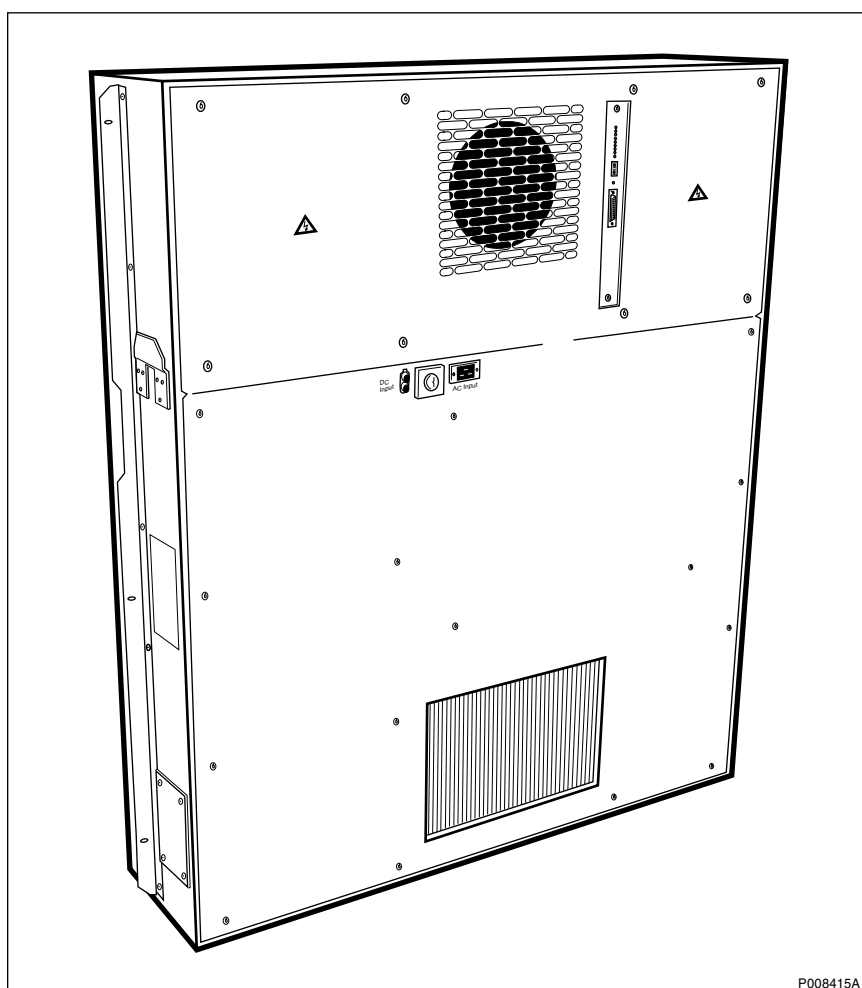

## Contents

<b>1</b>	<b>Product Overview</b>	<b>3</b>
1.1	Main Functions	3
<b>2</b>	<b>Dimensions</b>	<b>3</b>
<b>3</b>	<b>Power Consumption</b>	<b>3</b>
<b>4</b>	<b>Function Description</b>	<b>4</b>
4.1	Heat Exchanger	4
4.2	Active Cooler	5
4.3	Heater	5
4.4	Climate Control Unit	5
4.5	DC/DC Converter	6
4.6	AC/DC Converter	6
4.7	Transformer	6
<b>5</b>	<b>Interfaces</b>	<b>7</b>
5.1	Signal and Power Interfaces	7
5.2	Operator Interfaces	7



# 1 Product Overview

## 1.1 Main Functions

The Combined Climate Unit for the RBS 2106 has the following main functions:

- Provides the RBS cabinet with cooling or heating to maintain the operating temperature within specified limits.

## 2 Dimensions

The Climate Unit has the following dimensions:

*Table 1 Size and weight*

<b>Height</b>	<b>Width</b>	<b>Depth</b>	<b>Weight</b>
1250 mm	1050 mm	250 mm	105 kg

## 3 Power Consumption

*Table 2 Power consumption*

<b>Max AC power consumption</b>	<b>Max DC power consumption</b>
2300 W (at 230 V 50 Hz)	450 W

## 4 Function Description

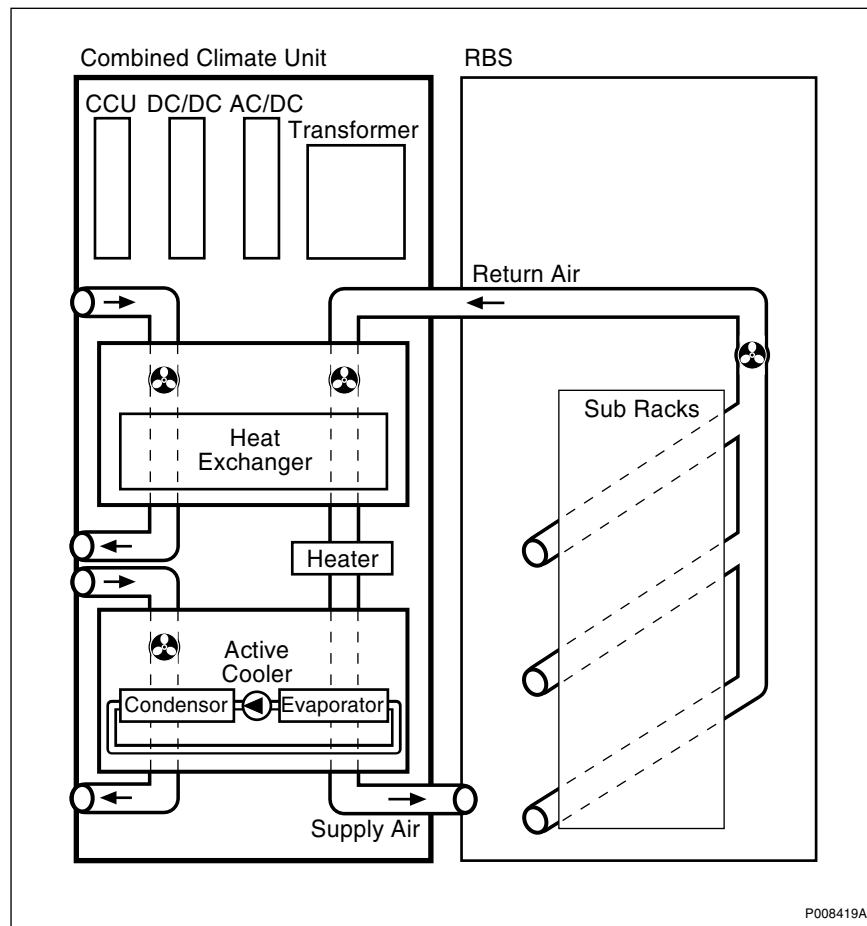

Figure 1 Block diagram

The Combined Climate Unit consists of the following units:

- Heat exchanger
- Active cooler
- Heater
- Climate Control Unit (CCU)
- DC/DC converter
- AC/DC converter
- Transformer

### 4.1 Heat Exchanger

This unit consists of a cross-flow heat exchanger, DC-powered internal and external air circuit fans.

The outside air circulates through one side of the heat exchanger and the inside air circulates through the other side. DC-powered fans force the air through the heat exchanger. The inside air is cooled by the outside air.

## 4.2 Active Cooler

This unit consists of a compressor, reducing valve, condenser, evaporator and an AC-powered condenser fan.

The liquid coolant passes through a reducing valve, where it evaporates to a cold low-pressure gas. This gas flows through the evaporator and cools it. The inside air that has passed the heat exchanger is blown through the evaporator, cooled and returned to the cabinet subracks.

The compressor compresses the coolant to a liquid state again in the condenser. The coolant and the condenser become hot in the process. An AC-powered fan circulates the outside air through the condenser and cools it.

When the temperature exceeds the compressor start point, the CCU supplies mains voltage, first to the condenser fan and then to the compressor. The condenser fan runs when the compressor is running and one minute after the compressor is switched off. The compressor cannot start again before the condenser fan has stopped. This is done to equalise the pressure differences in the cooling system before the compressor starts.

When the temperature decreases below the compressor stop value, a compressor stop signal is activated, but the compressor will continue running for at least 10 minutes.

If the mains current to the compressor is missing, it is reported as compressor failure.

The condenser fan is provided with a rotation signal output. If the signal is missing, an active cooler fan alarm is reported.

## 4.3 Heater

The heater is placed in the internal air circuit and heats the air if the ambient temperature is too low for start up.

The heater is powered by mains voltage, and heats the inside air if the start-up temperature inside the cabinet is below +5° C. The heater has a capacity of 2 kW.

The CCU measures the return air temperature and controls the heater.

## 4.4 Climate Control Unit

The Climate Control Unit (CCU) is a processor based plug-in unit, that controls and supervises the climate unit. It has a set of default operating parameters, which can be overridden by loaded parameters. The backplane connectors

contain the climate unit internal interfaces to DC power, AC power, fans, compressor, temperature sensors, and so on.

The front panel contains indicators, connectors for the EPC bus and a 25-pole D-sub connector for test and control.

The CCU provides the following main functions:

- Monitors internal and external temperatures
- Monitors and controls the internal and external fans
- Monitors and controls the compressor
- Monitors and controls the condenser fan
- Monitors and controls the heater
- Handles alarm
- Supervises mains voltage
- Test

The test function is activated by the button on the front panel. After the test has been completed, the indicators will present the status for two minutes. No alarm is sent if there is a malfunction. It is possible to change the behaviour of the climate unit by sending a set of parameters to the CCU through the EPC bus.

#### **4.5 DC/DC Converter**

The DC/DC converter operates on +24 V DC from the RBS. The converter feeds -48 V DC to the internal air circuit fan, external air circuit fan in the heat exchanger and the CCU.

#### **4.6 AC/DC Converter**

The AC/DC converter converts AC mains to -48 V DC for the internal air circuit fan, external air circuit fan in the heat exchanger and the CCU, when +24 V DC supply is not present.

#### **4.7 Transformer**

The transformer supplies fans, heater, compressor and AC/DC converter with 230 V AC, independent of the mains input voltage.

The transformer has windings for mains input voltages of 200, 208, 230, 240 and 250 V AC. The mains voltage is selected using the voltage selector switch.

## 5 Interfaces

### 5.1 Signal and Power Interfaces

The Combined Climate Unit has the following external interfaces:

- DC power
- AC mains power
- EPC bus (on CCU)
- Test and general signals (25-pole D-sub on CCU)

### 5.2 Operator Interfaces

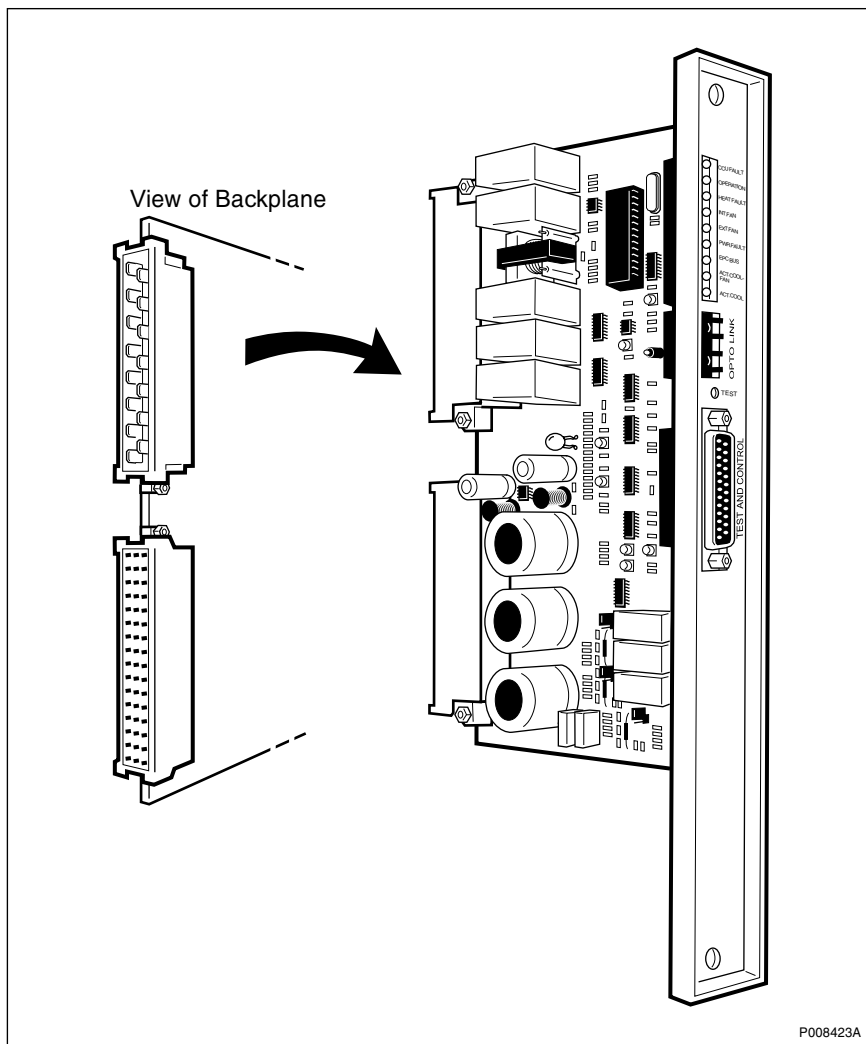

Figure 2 CCU

The CCU front panel has the following MMI interfaces:

- Indicators
- Test button
- Test and control connector

## Indicators

*Table 3 Indicators*

<b>Indicator</b>	<b>Colour</b>
CCU Fault	Red
Operation	Green
Heater fault	Yellow
Heat exchanger internal fan fault	Yellow
Heat exchanger external fan fault	Yellow
Power fault	Yellow
EPC bus fault	Yellow
Active cooler fan fault	Yellow
Active cooler fault	Yellow

# CXU-10

Configuration Switch Unit

## Unit Description

EN/LZT 720 0240 R1A

The Configuration Switch Unit (CXU) distributes the RX signals from the CDU to the dTRU within the same RBS.

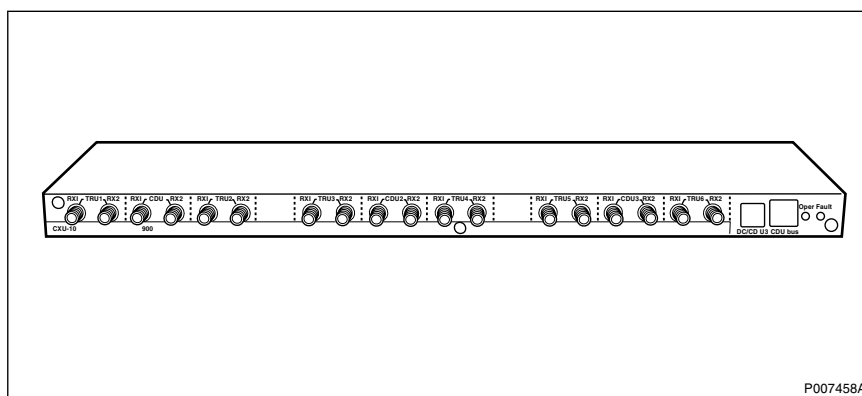

## Contents

<b>1</b>	<b>Product Overview</b>	<b>3</b>
1.1	Main Functions	3
<b>2</b>	<b>Dimensions</b>	<b>3</b>
<b>3</b>	<b>Power Consumption</b>	<b>3</b>
<b>4</b>	<b>Function Description</b>	<b>4</b>
4.1	Functions	4
<b>5</b>	<b>Interfaces</b>	<b>5</b>
5.1	Signal and Power Interfaces	5
5.2	Operator Interface	5



# 1 Product Overview

The CXU cross-connects the CDU and the dTRU in the RX path. The CXU makes it possible to expand or reconfigure a cabinet with a minimum of moving or replacing of RX cables.

The CXU is a multi-band product for GSM 800, GSM 900, GSM 1800 and GSM 1900.

## 1.1 Main Functions

The CXU has the following main functions:

- Supports both GMSK and 8-PSK
- One CXU can support up to three CDUs
- To configure the CXU, six switches can be set to connect different CDUs with different dTRUs

# 2 Dimensions

The CXU-10 has the following dimensions:

*Table 1 Size and weight*

Height	Width	Depth	Weight
22 mm	482.6 mm (19" standard)	120 mm	2 kg

# 3 Power Consumption

The maximum power consumption is 10 W.

## 4 Function Description

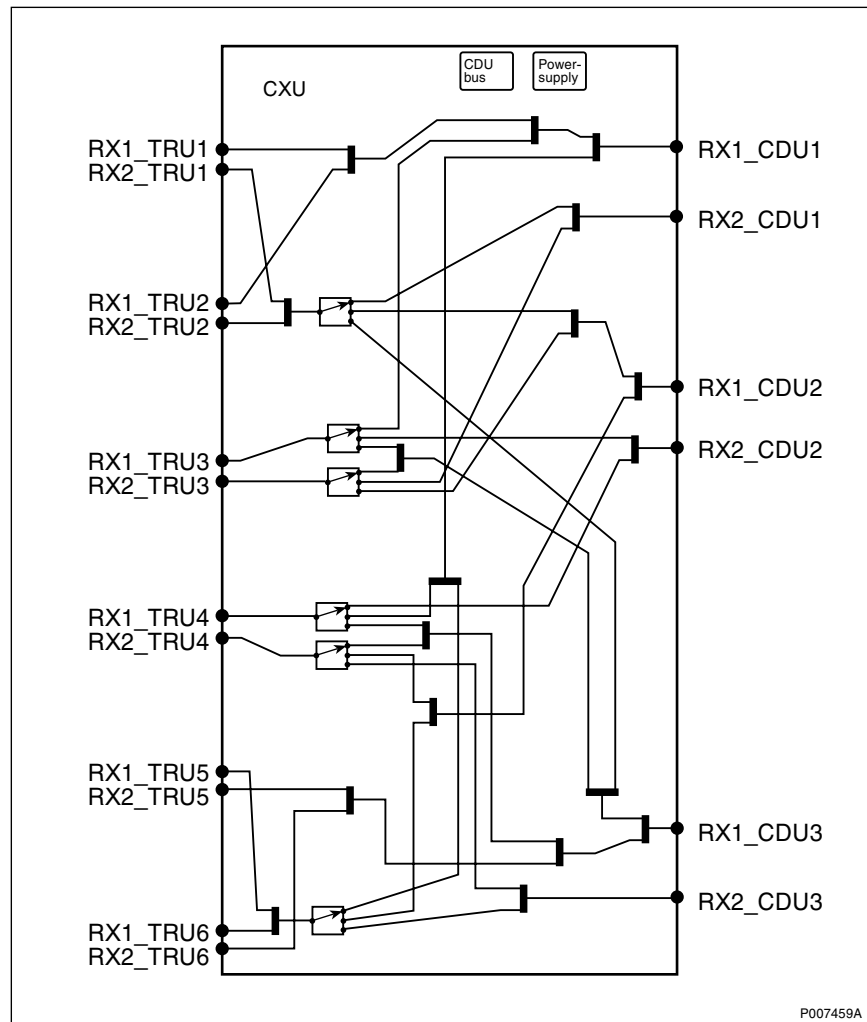

Figure 1 Block diagram of the CXU

### 4.1 Functions

The CXU has six different switches. By setting the switches in different positions, the CXU can be configured to connect radio signals from a specific CDU to a specific RX input on a dTRU.

The CXU is also connected to a CDU bus. By sending data through the CDU bus, the switches can be set to fulfil one of six supported configurations.

The unit contains splitters for distribution of incoming RX signals to the switches and in some cases directly to an output.

The RF cables between the CDU and CXU and the CXU and dTRU are supervised by the CXU.

## 5 Interfaces

### 5.1 Signal and Power Interfaces

*Table 2 Connectors*

<b>Function</b>	<b>Qty</b>
Input for RX signal from CDU	6
Output for RX signal to dTRU	12
CDU Bus connector for alarm and configuration setting	1
Power supply connector	1

### 5.2 Operator Interface

*Table 3 Indicators*

<b>Indicator</b>	<b>Colour</b>
Operational	Green
Fault	Red



# DCCU

DC Connection Unit

## Unit Description

EN/LZT 720 0224 R1A

The DC Connection Unit (DCCU) distributes primary power to the Power Supply Units.

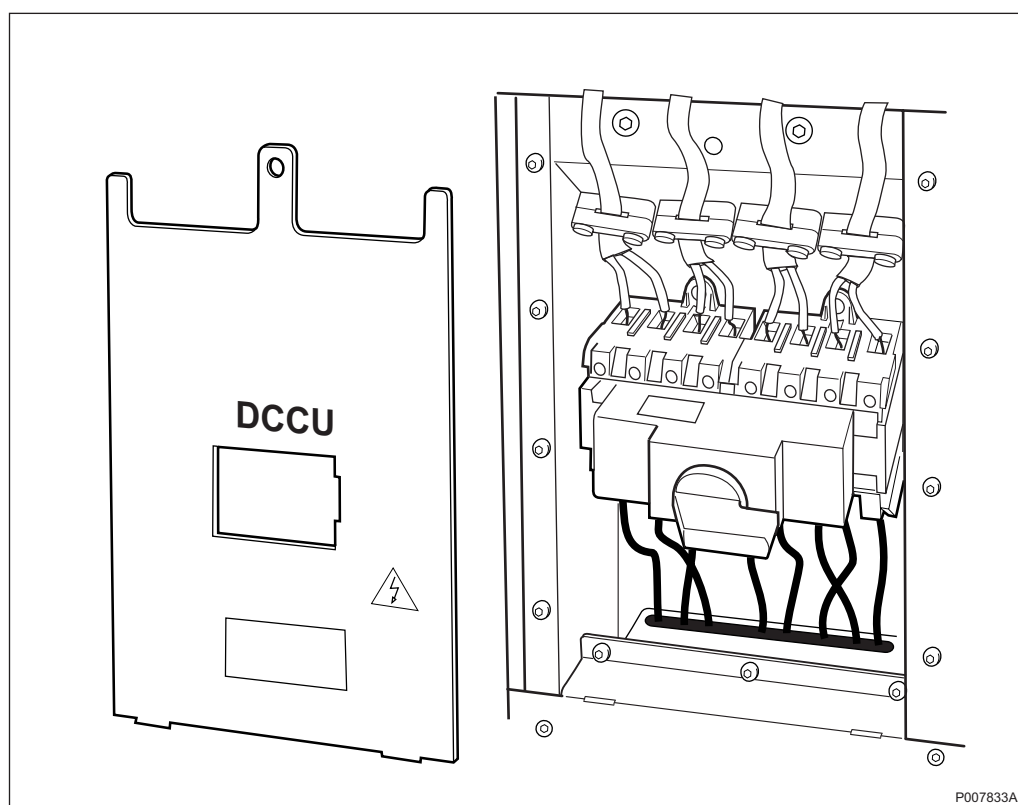

## Contents

<b>1</b>	<b>Product Overview</b>	<b>3</b>
1.1	Main Functions	3
<b>2</b>	<b>Dimensions</b>	<b>3</b>
<b>3</b>	<b>Function Description</b>	<b>3</b>
<b>4</b>	<b>Interfaces</b>	<b>3</b>
4.1	Signal and Power Interfaces	4

# 1 Product Overview

## 1.1 Main Functions

The DCCU distributes primary power to the PSUs and it has the following functions:

- Terminates incoming DC supply cables
- Disconnects incoming DC supply
- Filters EMC

## 2 Dimensions

The DCCU has the following physical characteristics:

*Table 1 Size and weight*

Height	Width	Depth	Weight
293.5 mm	141 mm	60 mm	5 kg <sup>(1)</sup>

(1) Including cables

## 3 Function Description

The DCCU consists of a box containing:

- Terminal block with incoming DC cables
- Eight-pole main switch (disconnecting device)
- A feed-through capacitor filter
- Four cables to the PSUs

## 4 Interfaces

The DCCU has the following interfaces:

- Terminal block for four incoming DC supply cables
- Four outgoing cables to the PSUs

## 4.1 Signal and Power Interfaces

The tables below show input and output data.

*Table 2 Input Data*

<b>Voltage</b>	-40 – -72 V DC
<b>External fuses</b>	4 pcs, max. 40 A
<b>Cable diameter</b>	4.5 – 7 mm
<b>Conductor area</b>	6 – 10 mm <sup>2</sup>
<b>Number of conductors</b>	2

*Table 3 Output Data*

<b>Conductor area</b>	6 mm <sup>2</sup>
<b>Number of conductors</b>	2



# DC/DC Converter

## +24 V DC to -48 V DC/DC Converter for RBS 2106

### Description

The DC/DC Converter converts +24 V DC into regulated -48 V DC with an output power of 200 W.

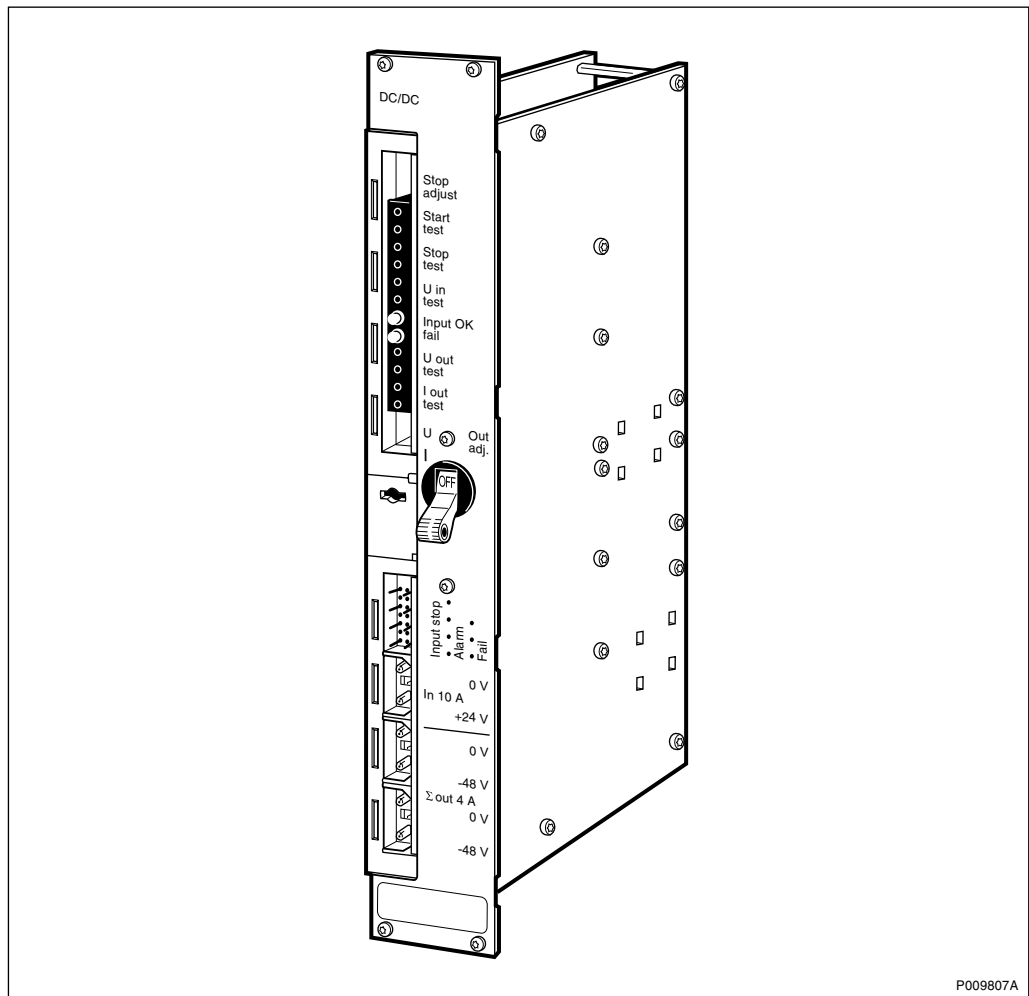

## Contents

<b>1</b>	<b>Product Overview</b>	<b>3</b>
1.1	Main Functions	3
<b>2</b>	<b>Dimensions</b>	<b>3</b>
<b>3</b>	<b>Power Consumption and Heat Generation</b>	<b>3</b>
<b>4</b>	<b>Function Description</b>	<b>4</b>
<b>5</b>	<b>Interfaces</b>	<b>5</b>
5.1	Signal and Power Interfaces	6
5.2	Operator Interface	6

# 1 Product Overview

The DC/DC converter converts +24 V DC battery voltage to regulated –48 V DC. The output power capacity is 200 W.

## 1.1 Main Functions

The DC/DC Converter has the following main functions:

- Voltage converter
- Current limitation
- Voltage regulation
- Overvoltage and undervoltage protection
- Switch on the front for switching on and off. The switch also serves as a circuit breaker for input voltage.
- Input and output connectors on the front panel.
- Remote-controlled start and stop

# 2 Dimensions

This section describes the physical characteristics of the DC/DC Converter.

*Table 1 Size and weight*

Height	Width	Depth	Weight
267 mm (6 HE x 44.45 mm)	41 mm (8 TE x 5.08 mm)	160 mm	1.2 kg

# 3 Power Consumption and Heat Generation

The maximum power consumed and heat generated during use are shown in the table below.

*Table 2 Maximum power and heat*

Max power consumption	Max heat generation
225 W	25 W

## 4 Function Description

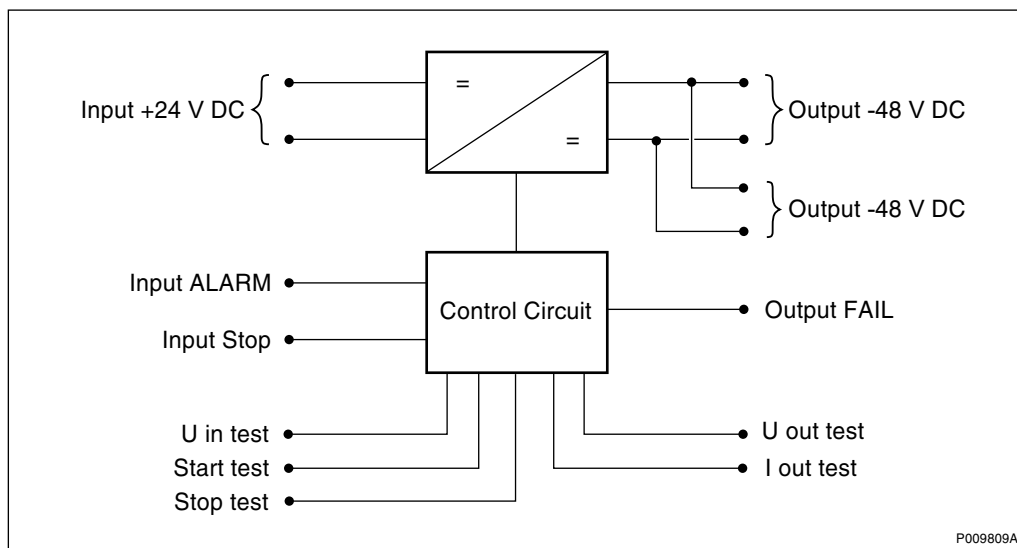

Figure 1 Block diagram

The unit is a switched converter, that converts +24 V DC battery voltage to regulated -48 V DC. The converter can be connected in parallel with other converters to operate continuously in current limitation mode.

The exact value of the output voltage can be adjusted using the potentiometer (“U out adj”) on the front panel. For adjustment range, see *Section 5.1 Signal and Power Interfaces*.

The current limitation is set to 100 – 115% of the rated current (4.0 A), above which the output voltage drops. The output current increases when the voltage drops, enabling the converter to be loaded with other DC/DC converters with an input power limited to approximately 150 W.

The overvoltage protector shuts down the switching when the output voltage reaches -58 V. The output is restored by switching the converter ON/OFF switch to OFF and then after 15 seconds to ON again.

The ON/OFF switch is also a resettable automatic fuse for the input current.

The undervoltage protector monitors the input voltage and blocks the converter at an input voltage of 18 – 21 V. The exact level is set by a potentiometer (“Stop adjust”) on the front of the unit. The converter is restored automatically when the input voltage rises 5 V above the stop level.

The converter can be stopped remotely by connecting a +5 V signal to the pin “Stop”. Normally this pin is left unconnected.

A green indicator on the front indicates that an input voltage, which has reached starting level, is present in the conversion stage.

A red indicator on the front is active when the output voltage is out of limits due to either overload, overvoltage, or failure.

## 5 Interfaces

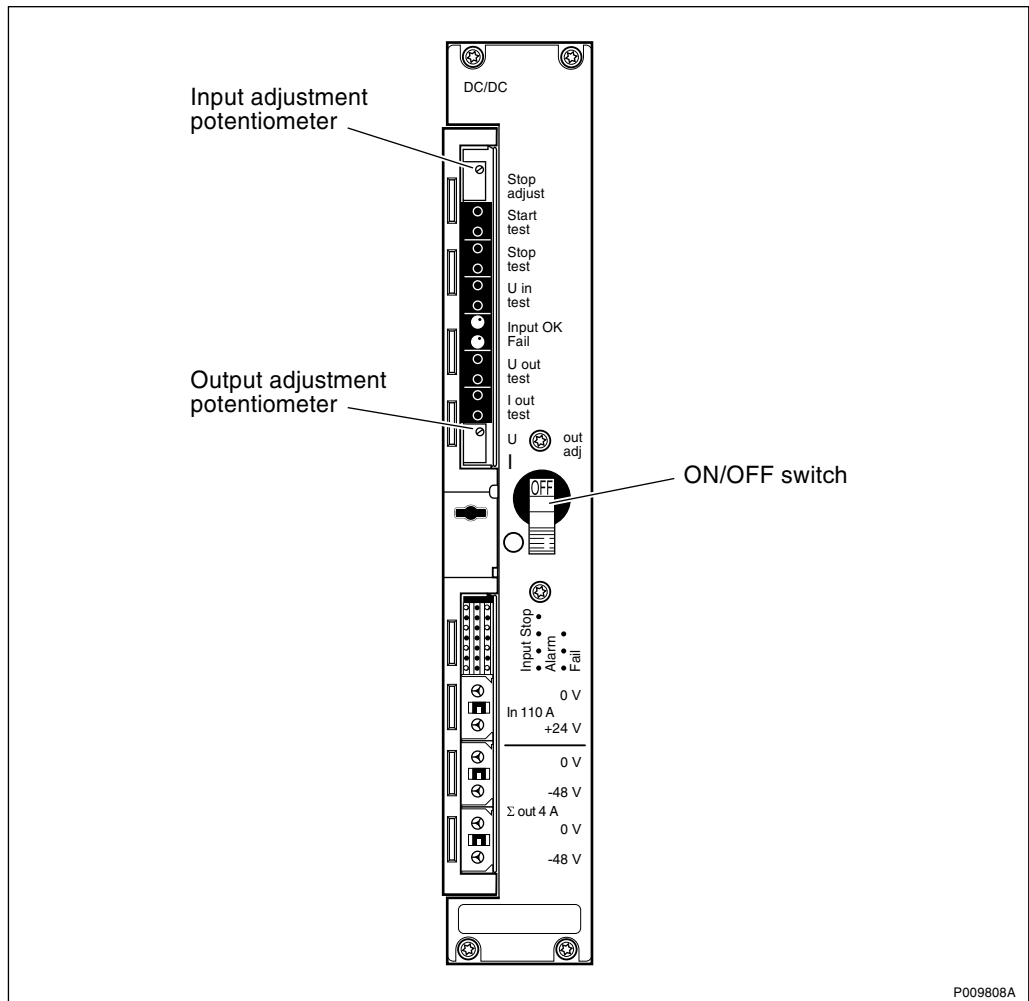

Figure 2 DC/DC Converter interfaces

## 5.1 Signal and Power Interfaces

### Input data

Table 3 Input power data

Nominal voltage	+24 V DC
Permitted variations	+18.0 to 31.0 V DC
Undervoltage protection	+18.0 to 21.0 V DC
Default start level	+23.5 ±0.2 V DC
Default stop level	+18.5 ±0.2 V DC
Rated power	200 W

### Output data

Table 4 Output power data

Rated voltage	-48 V DC	
Setting range	-46.0 to -57.0 V DC	
Default output	54 V DC	
Overvoltage protection	-57.5 to 59.5 V DC	
Output current	4.0 A at -48 V	
Efficiency at 200 W output	88%	
Current or power limitation at $U_{out}$ :	-54 V	225 W
	-48 V, 4.6 – 5.2 A	225 W
	-40 V, 5.0 – 6.0 A	225 W
Noise voltage, psophometric value	≤ 1 mV	

## 5.2 Operator Interface

The DC/DC Converter has the following interfaces, all located on the front panel:

- ON/OFF switch
- Input stop potentiometer
- Output stop adjustment potentiometer
- Start and Stop Test ports

- $U_{in}$  test port
- $U_{out}$  test port
- $I_{out}$  test port

## Indicators

*Table 5 Indicators*

<b>Indication</b>	<b>Colour</b>
Input OK	Green
Output fail	Red

Ericsson AB  
SE-164 80 Stockholm  
Sweden

[implementation.GSMsupport@era.ericsson.se](mailto:implementation.GSMsupport@era.ericsson.se)

Due to continued progress in methodology, design and manufacturing,  
the contents of this document are subject to change without notice.

© Ericsson AB



# DC Filter for RBS 2106

## Filter for External Batteries

### Description

The DC Filter Unit is the RBS 2106's interface for external +24 V DC power supply.

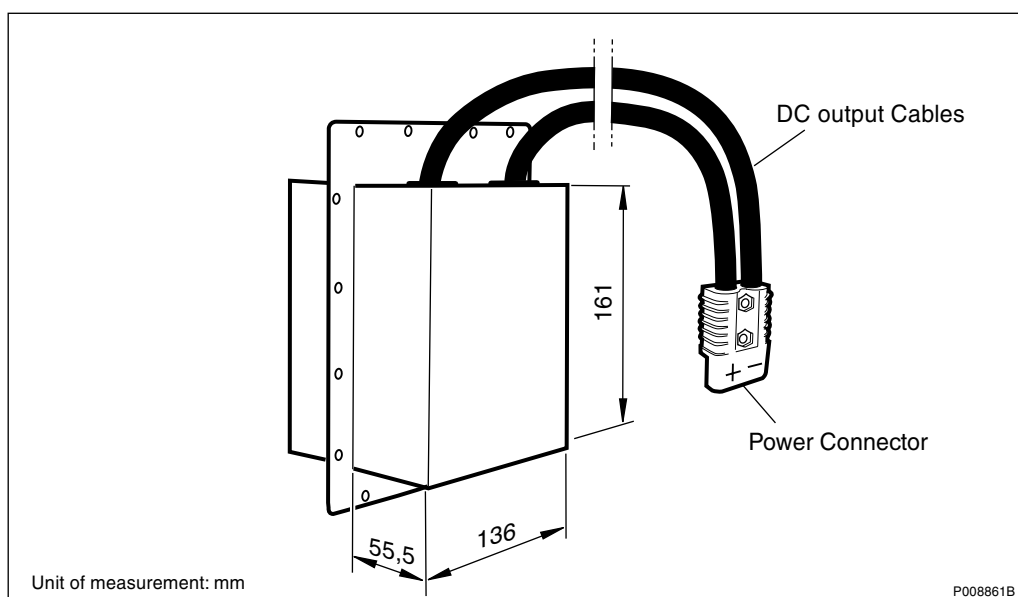

# Contents

<b>1</b>	<b>Product Overview</b>	<b>3</b>
1.1	Main Functions	3
<b>2</b>	<b>Dimensions</b>	<b>3</b>
<b>3</b>	<b>Function Description</b>	<b>3</b>
<b>4</b>	<b>Interface</b>	<b>4</b>
4.1	Signal and Power Interface	4

## 1 Product Overview

The DC Filter is the interface between a +24 V DC external power source, such as a battery, and the IDM inside the RBS 2106.

### 1.1 Main Functions

The DC Filter has the following main functions:

- EMC filtering
- Connection of +24 V DC to the cabinet
- Distribution of +24 V DC power to the IDM

## 2 Dimensions

The DC Filter has the following dimensions:

*Table 1 Size and weight*

Height	Width	Depth	Weight
121 mm	222 mm	171 mm	5 kg

## 3 Function Description

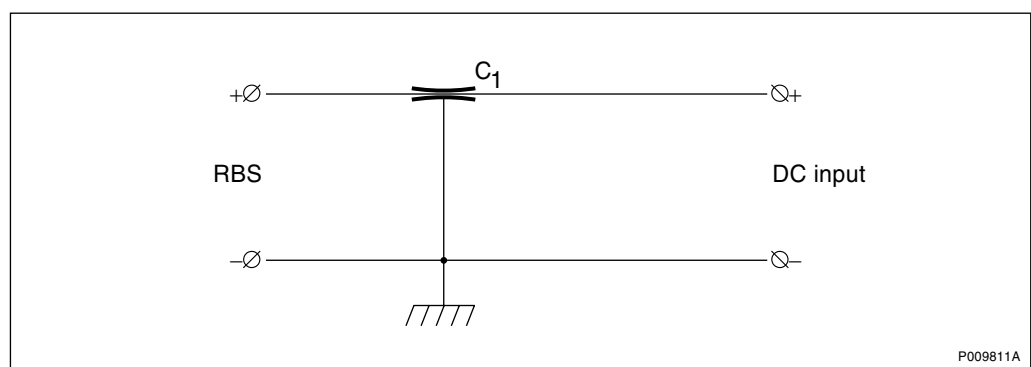

*Figure 1 Circuit diagram*

This unit filters the incoming +24 V DC to conform with the internal requirements of the RBS 2106.

The filter is formed by a coaxial feed-through capacitor. The capacitor provides full 360° earthing around the cable.

The DC Filter serves as an EMC barrier against the outside electrical environment and a mechanical barrier against the outside climatic environment.

## 4 Interface

### 4.1 Signal and Power Interface

The DC Filter has the following external interfaces:

- Two input terminals for 70 – 185 mm<sup>2</sup> cables. The input terminals are of semi-enclosed clamp type.
- Strain-relief clamps for cables with diameter 14 – 26 mm.
- Output cable negative (-) is a 70 mm<sup>2</sup> cable, about 420 mm long, with an Anderson power plug.
- Output cable positive (+) is a 70 mm<sup>2</sup> cable, about 420 mm long, with an Anderson power plug.
- A hole for an optional temperature sensor connector is provided.

### Voltage and current

Table 2 Limiting values

Rated voltage	100 V DC
Feed-through current	175 A

# DC Filter 01 for RBS 2206

## Description

The DC filter is the interface for +24 V DC supply to the cabinet.

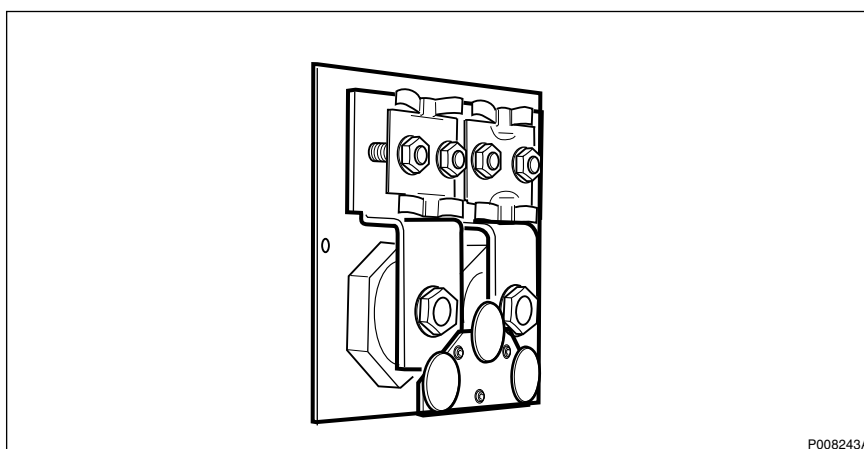

## Contents

<b>1</b>	<b>Product Overview</b>	<b>3</b>
1.1	Main Functions	3
<b>2</b>	<b>Dimensions</b>	<b>3</b>
<b>3</b>	<b>Function Description</b>	<b>3</b>
<b>4</b>	<b>Interface</b>	<b>3</b>
4.1	Signal and Power Interface	3

## Product Overview

### 1.1 Main Functions

The DC filter has the following main functions:

- Provides the interface for +24 V DC supply to the cabinet
- Distributes +24 V DC to the Internal Distribution Module (IDM).

## 2 Dimensions

The DC filter has the following dimensions:

*Table 1 Dimensions*

Height	Width	Depth	Weight
293.5 mm	164 mm	70 mm	6 kg (incl. Cables)

## 3 Function Description

The DC-filter has the following functions:

- Filters EMC
- Connects incoming 70 – 185 mm<sup>2</sup> power cables
- Protects incoming cables from pulling forces
- Power connection for internal distribution

## 4 Interface

### 4.1 Signal and Power Interface

The DC-filter has the following external interfaces:

- Two input terminals for 70 – 185 mm<sup>2</sup>
- Pull-relief clamps for incoming power cables with diameter 14 – 26 mm
- Two 70 mm<sup>2</sup> output cables

*Table 2 Input data*

Input voltage	Nominal +24 V DC Range 20.0 – 29.0 V DC
Non-destructive range	0.0 - +32.0 V DC
Max input current	200 A



# dTRU

Double Transceiver Unit

## Unit Description

EN/LZT 720 0242 R1A

The double Transceiver Unit (dTRU) is a 2-TRX replaceable unit. A TRX is a transmitter/receiver and signal-processing unit, which transmits and receives one carrier.

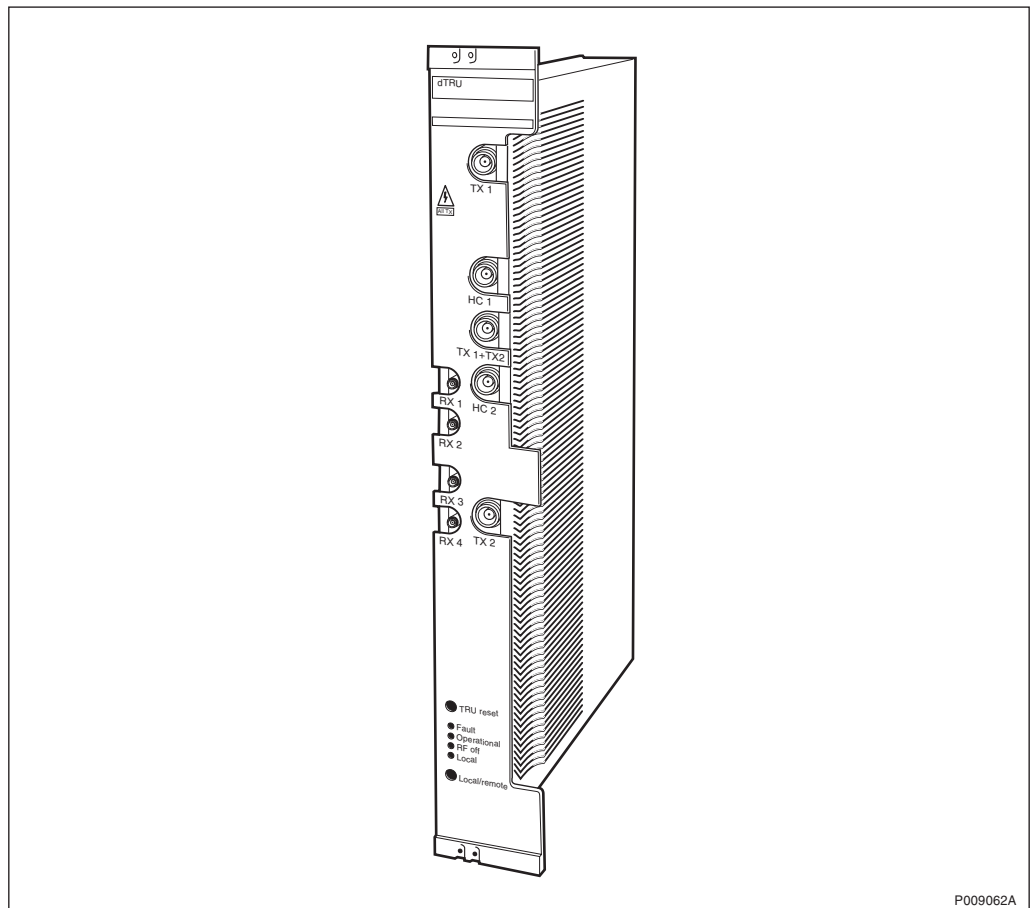

## Contents

<b>1</b>	<b>Product Overview</b>	<b>3</b>
1.1	Main Functions	3
<b>2</b>	<b>Dimensions</b>	<b>3</b>
<b>3</b>	<b>Power Consumption and Heat Generation</b>	<b>3</b>
<b>4</b>	<b>Function Description</b>	<b>4</b>
4.1	CPU System	5
4.2	DSP System	5
4.3	Radio Control System	5
4.4	Radio System	5
<b>5</b>	<b>Interfaces</b>	<b>5</b>
5.1	Signal and Power Interfaces	6
5.2	Operator Interface	6

# 1 Product Overview

The dTRU is a 2-TRX replaceable unit. A TRX is a transmitter/receiver and signal-processing unit, which transmits and receives one carrier. There are different versions of dTRU depending on the frequency band and modulation capability, that is, both GMSK and 8PSK (EDGE) or GMSK only.

The dTRU has two TX antenna terminals and four RX antenna terminals. The dTRU features a built-in hybrid combiner. The hybrid combiner can be used to combine the two TX antenna terminals to one common terminal.

Two of the RX antenna terminals are used for 2-branch diversity reception. The dTRU is hardware prepared for 4-branch diversity reception through the remaining two antenna terminals.

## 1.1 Main Functions

The dTRU is a distributed main CPU DMCN and its main functions are:

- Transmits and receives radio frequency signals – GMSK or 8PSK modulation
- Processes signals

# 2 Dimensions

The dTRU has the following dimensions:

*Table 1 Size and weight*

Height	Width	Depth	Weight
400 mm (9 HE x 44.45 mm)	71 mm (14 TE x 5.08 mm)	270 mm	7.6 kg

# 3 Power Consumption and Heat Generation

*Table 2 Power consumption and heat generation*

Max. power consumption	Max. heat generation
485 W	380 W

## 4 Function Description

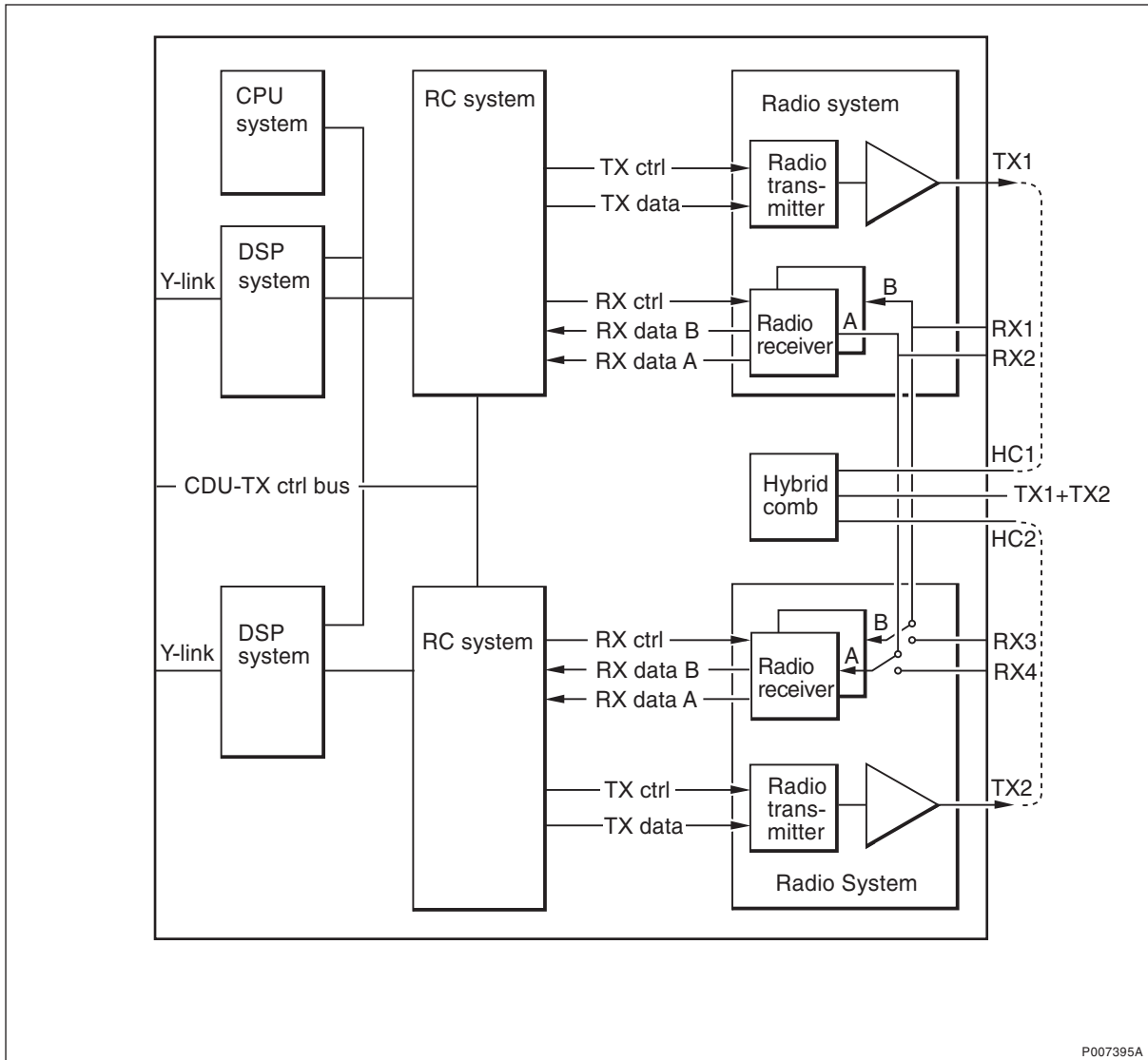

Figure 1 Block diagram of the dTRU

The TRU consists of the following main blocks:

- CPU system
- DSP system
- RC system
- Radio system

#### **4.1 CPU System**

The CPU system is a control unit in the RBS. It consists of a CPU, support logic, memory and logic for handling the interfaces.

#### **4.2 DSP System**

The DSP system performs all baseband signal processing necessary for one TRX. For downlink, this includes Terrestrial Protocol Handling (TPH), encoding, ciphering and burst generation. For uplink it includes equalization, combining, decoding and TPH.

#### **4.3 Radio Control System**

The RC system is responsible for synchronizing and controlling the different parts of the radio, for modulation and D/A conversion of the data to transmit, for filtering the received radio signal with a channel selective filter and for compensating the RX and TX delay and gain variations.

The RC system is seen by the rest of the RBS as the front end to the radio, which can be asked to transmit a burst of data using a selected modulation, or asked to receive a burst using a selected digital filter.

All time critical radio control functions are performed by the RC system and no computing support is required from the CPU system on a real-time basis.

#### **4.4 Radio System**

Each radio system contains two radio receivers and one radio transmitter including power amplifiers.

The radio receiver receives RF modulated uplink data from one or two diversity branches and sends it to the RC system.

The radio transmitter generates the RF downlink signal from the modulated baseband signal. It then sends the RF signal to the power amplifier, which amplifies the downlink RF signals.

### **5 Interfaces**

The dTRU has the following external interfaces:

- CDU-TX control bus, IOM bus
- IOM bus, LEDs and buttons

- RX (front)
- TX (front)
- Y link

## 5.1 Signal and Power Interfaces

The Y link, CDU TX control bus, system voltage and connectors are located on the backplane.

## 5.2 Operator Interface

*Table 3 Indicators*

Indicator	Colour
Fault	Red
Operational	Green
RF off	Yellow
Local mode	Yellow

*Table 4 Switches*

Switch	Function
TRU reset	Resets the TRU
Local/remote	Local/remote mode

# DXU-21

Distribution Switch Unit

## Unit Description

EN/LZT 720 0244 R1A

The Distribution Switch Unit (DXU) is a CPU, which acts as an interface between the transmission network and the transceivers. It also extracts timing information from the PCM link and generates a timing reference for the RBS.

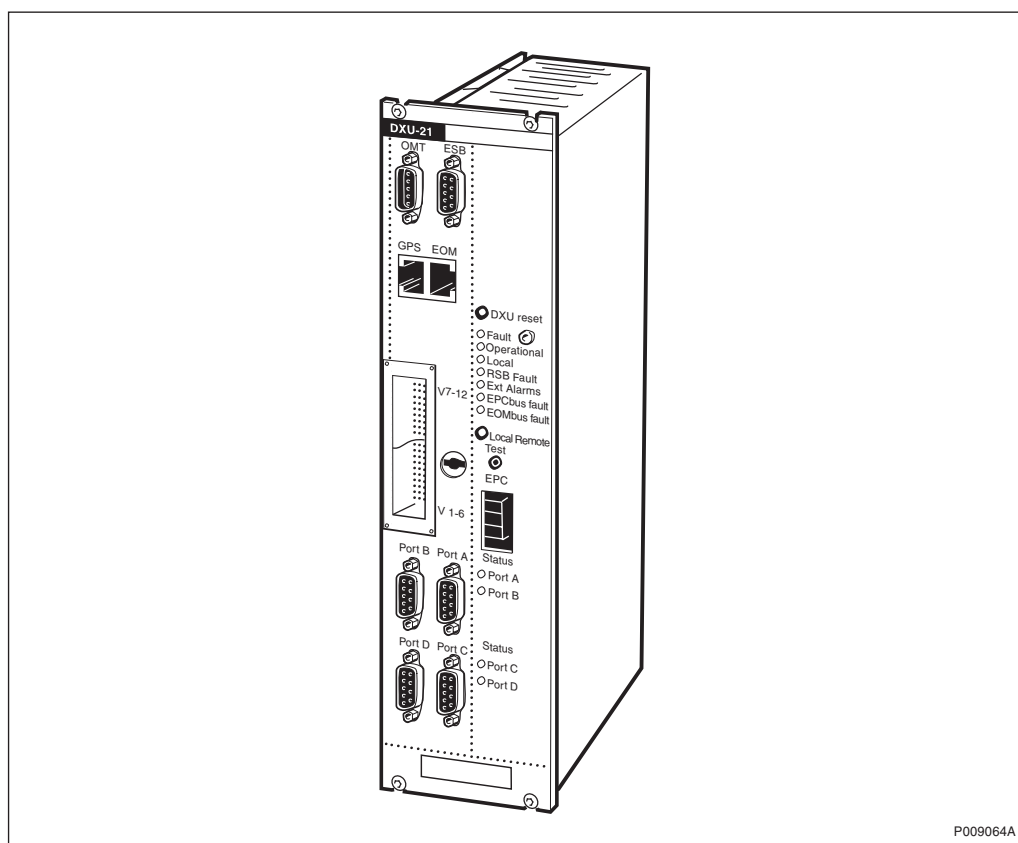

## Contents

<b>1</b>	<b>Product Overview</b>	<b>3</b>
1.1	Main Functions	3
<b>2</b>	<b>Dimensions</b>	<b>3</b>
<b>3</b>	<b>Power Consumption and Heat Generation</b>	<b>3</b>
<b>4</b>	<b>Function Description</b>	<b>4</b>
4.1	CPU System	5
4.2	Communication Switch System	5
4.3	Transmission Interface Controller	5
4.4	Power Supply	6
4.5	Timing System	6
4.6	Miscellaneous Logic	6
4.7	Compact Flash Card	6
<b>5</b>	<b>Interfaces</b>	<b>6</b>
5.1	Signal and Power Interfaces	6
5.2	Operator Interface	9



# 1 Product Overview

The DXU-21 is a CPU, which acts as an interface between the transmission network and the transceivers. It also extracts timing information from the PCM link and generates a timing reference for the RBS. The DXU also performs supervisory tasks.

The DXU-21 transmission interface has long-haul capability and can be run on both 1.544 Mbit/s (T1) and 2.048 Mbit/s (E1) PCM links.

## 1.1 Main Functions

The DXU serves as the Central Main CPU node and its main functions are:

- Provides the RBS with an interface to the transport network through four fixed E1/T1 transmission ports
- Handles incoming traffic, controls and supervises information and sends it to its destination within the RBS
- Provides frequency reference signals and timing signals for circuits within the RBS
- Stores and executes RBS SW stored on a removable flash card
- Controls the climate and power system

# 2 Dimensions

The DXU-21 has the following dimensions:

*Table 1 Size and weight*

Height	Width	Depth	Weight
227 mm (6 HE x 44.45 mm)	71 mm (14 TE x 5.08 mm)	240 mm	2.4 kg

# 3 Power Consumption and Heat Generation

*Table 2 Power consumption and heat generation*

Max. Power Consumption	Max. Heat Generation
40 W (typical 30 W)	40 W

# 4 Function Description

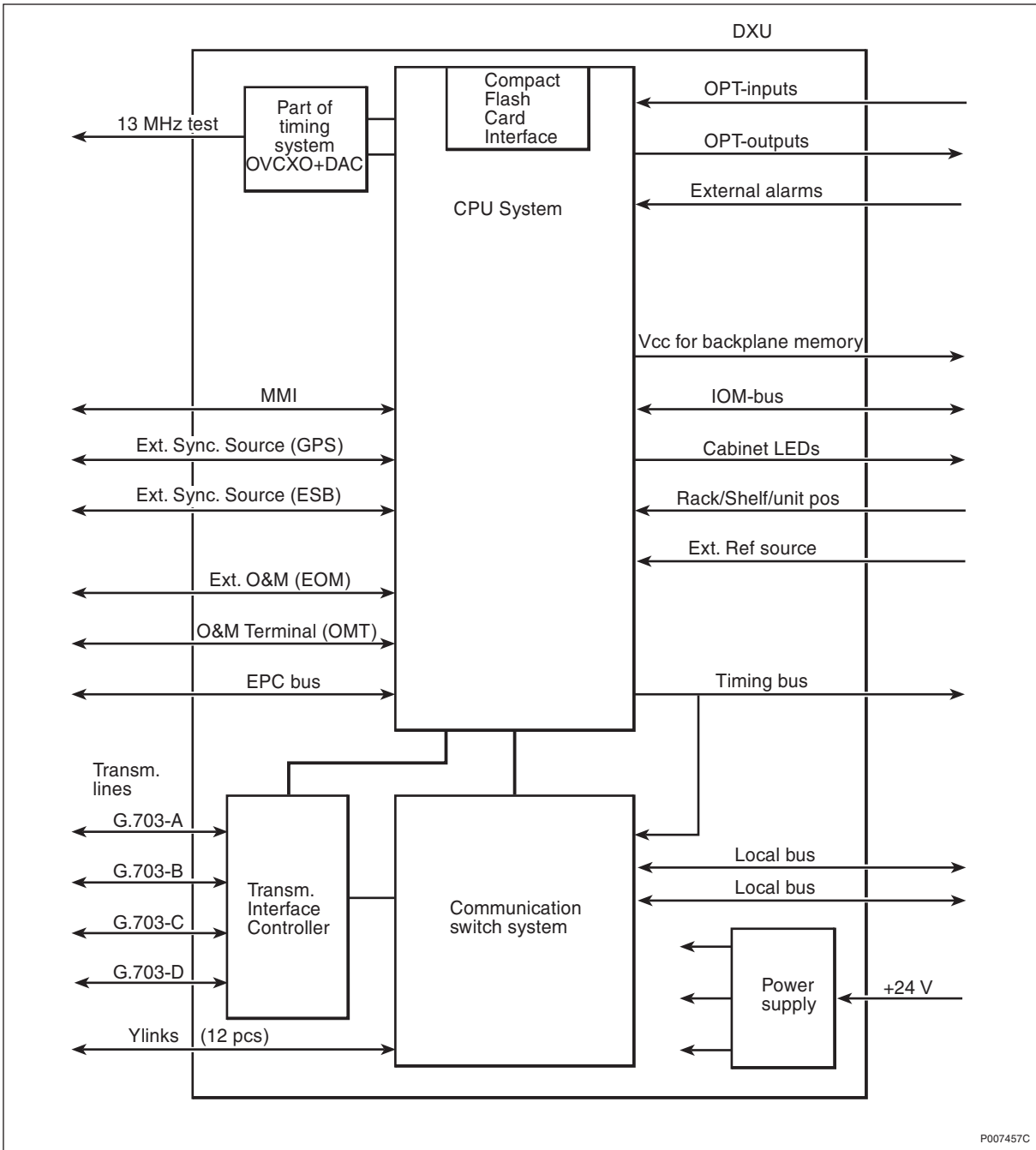

Figure 1 DXU-21, block diagram

Electrically, the DXU-21 consists of the following main blocks:

- CPU system
- Communication switch system
- Transmission interface controller
- Power supply
- Timing system
- Miscellaneous logic
- Compact Flash Card

#### **4.1 CPU System**

The heart of the DXU-21 is a 32-bit embedded controller with a PPC 405 processor core with interfaces to a wide range of peripherals.

The CPU system consists of:

- I<sup>2</sup>C controller
- Ethernet 10/100 Mbit/s (full-duplex) controller, MAC
- SDRAM memory
- FLASH memory
- ASIC GARP
- Compact Flash Card

#### **4.2 Communication Switch System**

This system block contains circuits that handle traffic between the BSC and the dTRUs.

#### **4.3 Transmission Interface Controller**

This part contains circuits for four transmission links and the transmission interface controller, which controls the traffic for all four transmission links.

The bit rate is SW controlled. Two speeds are available: E1 (2.048 Mbit/s) or T1 (1.544 Mbit/s).

#### **4.4 Power Supply**

The power supply delivers all the voltages necessary for the DXU-21. The input voltage, +24 V DC, is supplied through backplane connectors.

#### **4.5 Timing System**

The timing system is used for generating a 13 MHz clock signal.

#### **4.6 Miscellaneous Logic**

This function contains the following:

- System voltage measurement
- Temperature measurement
- Power on reset

#### **4.7 Compact Flash Card**

The removable Compact Flash Card permits quick and easy change of the SW and IDB in the DXU.

### **5 Interfaces**

#### **5.1 Signal and Power Interfaces**

##### **G.703 Interface**

The four G.703 interfaces are connected to the BSC (Protocol GSM-Abis) or to cascaded base stations. In cascade mode, this interface can control an external bypass relay. Unused time slots can be through-connected to a successive base station. The communication speed in E1 interfaces is 2 Mbit/s and in T1, 1.5 Mbit/s.

##### **External Alarm Inputs**

Through this interface it is possible to connect up to 15 binary alarms (16 including one dedicated alarm). This interface is found on the upper backplane connector.

The equipment connected to the terminals should be insulated relay contacts. A closed contact (logic zero) is required to be below 2 k $\Omega$ , and an open contact (logic one) is required to be above 100 k $\Omega$ .

The current through a closed 0 contact is 1.2 mA.

The alarm contacts connected to the external alarm inputs should be insulated and have a current range above 1.2 mA. The voltage between terminals with an open contact is +24 V DC.

### **Local Bus**

The local bus is a time slot and multidrop bus, where the DXU-21 is the master of the bus. Two identical local buses are implemented, with common frame synchronization and clock signals. The interface is accessed through the lower backplane connector. The local bus is used for TRUs and sTRUs.

### **Timing Bus**

This interface is used for distribution of timing information to the TRUs through the backplane. The interface is accessed through the lower backplane connector. The timing bus is only used for TRUs.

### **External Sync. (Freq. Ref.)**

This interface is used for connecting an external frequency reference. It uses a generic synchronization port for the synchronization information.

### **Optional Output**

This interface enables control of up to eight devices, which can be of various types. These outputs are accessed through the upper backplane connector.

### **Optional Input**

This interface enables connection of up to eight internal cabinet signals, such as alarms. These inputs are accessed through the upper backplane connector.

### **IOM Bus**

This interface consists of three individual I<sup>2</sup>C ports. It is used to communicate with the CDU, CXU and cabinet ID.

An I<sup>2</sup>C bus is reserved for reading a memory device which identifies the source for the system.

The interface is accessed through the lower backplane connector.

### **Y Links**

This interface is used for communication with the dTRUs and sTRUs. The Y interface consists of 12 separate Y links.

The Y links are accessed through connectors located on the front of the DXU.

### **EPC Bus (Optical Cable)**

This interface is used for communication with the power supply equipment in the RBS, such as PSUs and BFU.

The optical communication interface is accessible through connectors located on the front of the DXU. The connectors are marked "EPC".

### **External Sync. (GPS/LMU)**

This interface is used for interfacing an external sync./frequency source, such as GPS. It is accessed through a connector of type 8-pin RJ-45, located on the front of the DXU. The connector is marked "GPS".

### **GPS/LMU**

This interface is identical to the serial line used in the interface "External sync. 1".

It is possible to use this interface from the backplane together with the interface "External sync. 0", as an alternative to the GPS interface.

This interface is accessed through the lower backplane connector.

### **External O&M (EOM)**

The EOM bus is designed as a standard Ethernet port and is intended for a site-LAN to communicate with other units on the site. Both half-duplex and full-duplex operation at 10 Mbps and 100 Mbps operation are supported.

The EOM bus is accessed through a connector located on the front of the DXU marked "EOM". The connector is of type 8-pin RJ-45.

## ESB

This interface is used to synchronize several transceiver groups in the same cell, for example when one cell is built up by more than one RBS, or one cell is split between two RBSs.

**Note:** A master-slave configuration, as in RBS 2202, is regarded as one transceiver group.

The interface is accessed on the front of the DXU through a D-sub 9-pin male connector marked "ESB".

## 5.2 Operator Interface

### OMT

The OMT port is used to communicate with the Operation and Maintenance Terminal.

The OMT is connected through a 9-pin D-sub female connector.

The OMT connection is galvanically separated. All signals use RS 232 levels.

*Table 3 The OMT connector pins and their functions*

Pin	Function
1	DCD, looped from DTR (pin 4)
2	RXD, data out of DXU
3	TXD, data into DXU
4	DTR, looped to DCD (pin 1) and DSR (pin 6)
5	Signal ground
6	DSR, looped from DTR (pin 4)
7	RTS, looped to CTS (pin 8)
8	CTS, looped from RTS (pin 7)
9	RI not connected

**Note:** The connector is configured as a DCE, and thus should be connected to an IBM PC style DTE (such as a computer) with a straight cable.

### Test Interface

This interface is used for test purposes only. It consists of a buffered version of the 13 MHz signal from the OVCXO. The signal is sinusoidal shaped and is suited for a coaxial cable load of 50  $\Omega$ .

The test interface has an SMB connector.

## Indicators and Buttons

There are 11 indicators located on the front panel (as shown in the table below) and two buttons for DXU Reset and Local/remote.

*Table 4 Indicators*

<b>Indicator</b>	<b>Colour</b>
Fault	Red
Operational	Green
Transmission OK (port A, B, C, D)	Green (4 pcs)
Local	Yellow
RBS fault	Yellow
External alarm	Yellow
EPC bus fault	Yellow
EOM bus fault	Yellow

*Table 5 Switches*

<b>Switch</b>	<b>Function</b>
DXU reset	Resets the DXU
Local remote	Sets local/remote mode



# FCU-01

Fan Control Unit

## Unit Description

EN/LZT 720 0246 R1A

The Fan Control Unit (FCU) controls and supervises the fans in the RBS 2206. It has indicators that show fan status information.

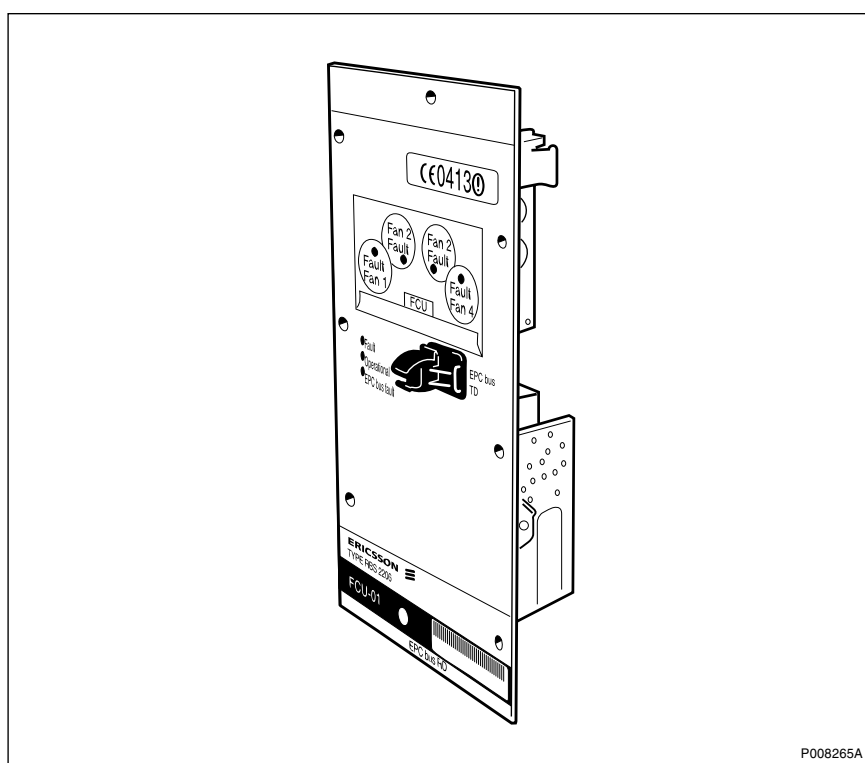

## Contents

<b>1</b>	<b>Product Overview</b>	<b>3</b>
1.1	Main Functions	3
<b>2</b>	<b>Dimensions</b>	<b>3</b>
<b>3</b>	<b>Function Description</b>	<b>3</b>
<b>4</b>	<b>Interface</b>	<b>4</b>
4.1	Signal and Power Interface	4
4.2	Operator Interface	4

# 1 Product Overview

The Fan Control Unit (FCU) controls and supervises the fans in an RBS cabinet.

## 1.1 Main Functions

The FCU-01 has the following main functions:

- Controls and supervises fans
- Generates alarm
- MMI for the fans

# 2 Dimensions

The FCU-01 has the following physical characteristics:

*Table 1 Size and weight*

Height	Width	Depth	Weight
195 mm	98 mm	45 mm	0.5 kg

# 3 Function Description

The FCU receives information on the EPC bus about the required DC voltage level for each fan. It feeds each fan with the required DC voltage level. If no DC level is received, the DC level for the fans will be equal to the FCU input voltage, minus a maximum voltage drop of 0.7 V.

If the normally closed circuit in the fan is opened, the indicator "Fan fault" for that fan is illuminated, and an alarm is sent through the EPC bus.

The FCU compares the DC level for each fan with the required DC level. If these do not match, the indicator "FCU fault" is illuminated, and an alarm is sent through the EPC-bus.

If the communication on the bus no longer is defined, the indicator "EPC bus fault" is illuminated, and an alarm is sent through the EPC bus to the DXU.

## 4 Interface

The FCU has the following interfaces:

- Power in
- EPC bus in
- EPC bus out
- Fan power and alarm (1 – 4)

### 4.1 Signal and Power Interface

The tables below show input and output data.

*Table 2 Input data*

<b>Nominal input voltage</b>	+24.0 V DC
<b>Input voltage Range</b>	+19.0 – +29.0 V DC
<b>Non destructive voltage</b>	0.9 – +32.0 V DC
<b>Input power</b>	4 x 45 W

*Table 3 Output data*

<b>Output voltage</b>	9 – 28.3 V DC
<b>Output Current</b>	Min 1.8 A at 9 – 28.3 V DC

### 4.2 Operator Interface

There is one alarm signal for each fan. The alarm circuit is normally closed.

An open circuit indicates that the fan speed is too low. The fan has an open collector interface.

*Table 4 No alarm*

<b>Alarm pos. <math>U_{pos}</math></b>	5 – 30 V DC
<b>Alarm neg. <math>U_{neg}</math></b>	$<U_{pos} - 2.4$ V DC
<b>Current <math>I_{no\_alarm}</math></b>	5 – 20 mA

Table 5 Alarm

<b>Alarm pos. <math>U_{\text{pos}}</math></b>	5 – 30 V DC
<b>Alarm neg. <math>U_{\text{neg}}</math></b>	< 2 V DC
<b>Current <math>I_{\text{alarm}}</math></b>	< 5 mA

## Indicators

Table 6 Indicators

<b>Indicator</b>	<b>Colour</b>
Fault	Red
Operational	Green
EPC bus fault	Yellow
Fan 1 fault	Red
Fan 2 fault	Red
Fan 3 fault	Red
Fan 4 fault	Red



# Heat Exchanger Climate Unit

## Climate Unit for RBS 2106

### Description

The Heat Exchanger Climate Unit provides the RBS 2106 with cooling or heating to keep the operating temperature within specified limits. The unit contains a heat exchanger, a heater, air-ducts and fans.

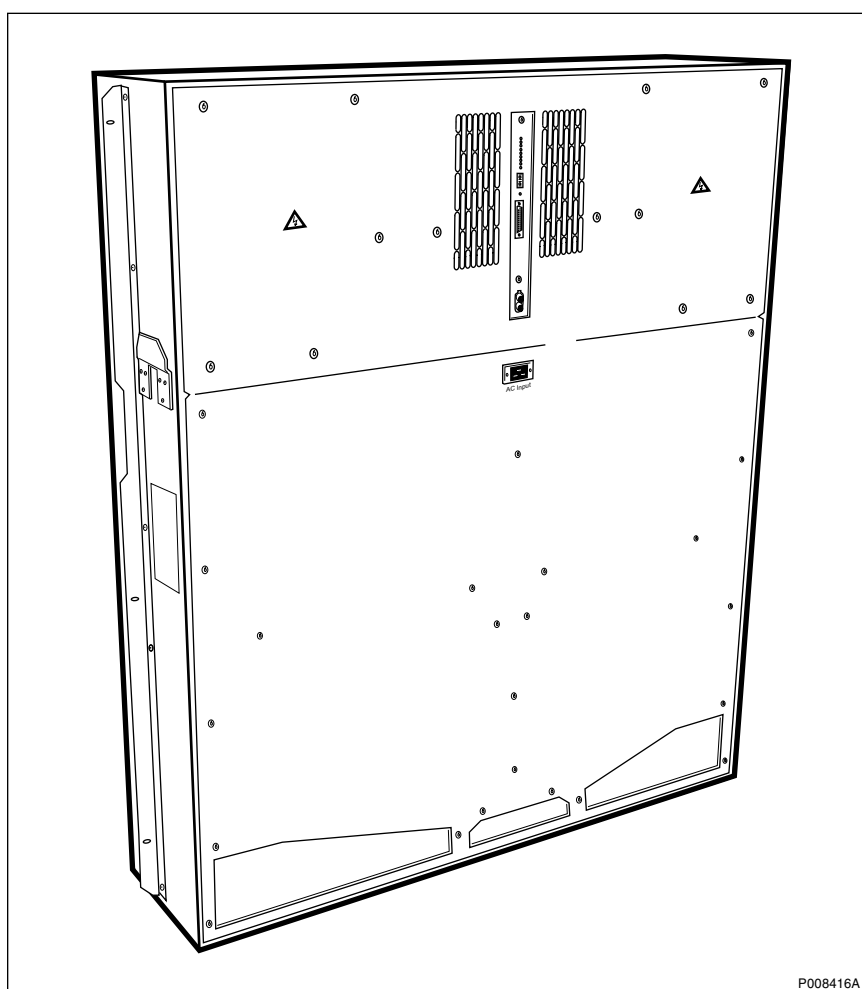

## Contents

<b>1</b>	<b>Product Overview</b>	<b>3</b>
1.1	Main Functions	3
<b>2</b>	<b>Dimensions</b>	<b>3</b>
<b>3</b>	<b>Power Consumption</b>	<b>3</b>
<b>4</b>	<b>Function Description</b>	<b>4</b>
4.1	Heat Exchanger	4
4.2	Heater	5
4.3	Climate Control Unit	5
4.4	AC/DC Converter	6
4.5	Autotransformer	6
<b>5</b>	<b>Interfaces</b>	<b>6</b>
5.1	Signal and Power	6
5.2	Operator Interface	7



# 1 Product Overview

The Heat Exchanger Climate Unit provides the RBS 2106 with cooling or heating to keep the operating temperature within specified limits. The unit contains a heat exchanger, a heater, air-ducts and fans.

## 1.1 Main Functions

The Heat Exchanger Climate Unit maintains the cabinet operating temperature within specified limits by heating or cooling.

# 2 Dimensions

The Heat Exchanger Climate Unit has the following dimensions:

*Table 1 Size and weight*

<b>Height</b>	<b>Width</b>	<b>Depth</b>	<b>Weight</b>
1250 mm	1050 mm	250 mm	97 kg

# 3 Power Consumption

Power consumption information for the Heat Exchanger Climate Unit is shown in the table below.

*Table 2 Power consumption*

<b>Max AC power consumption</b>	<b>Max DC power consumption</b>
2100 W (at 230 V 50 Hz)	650 W

## 4 Function Description

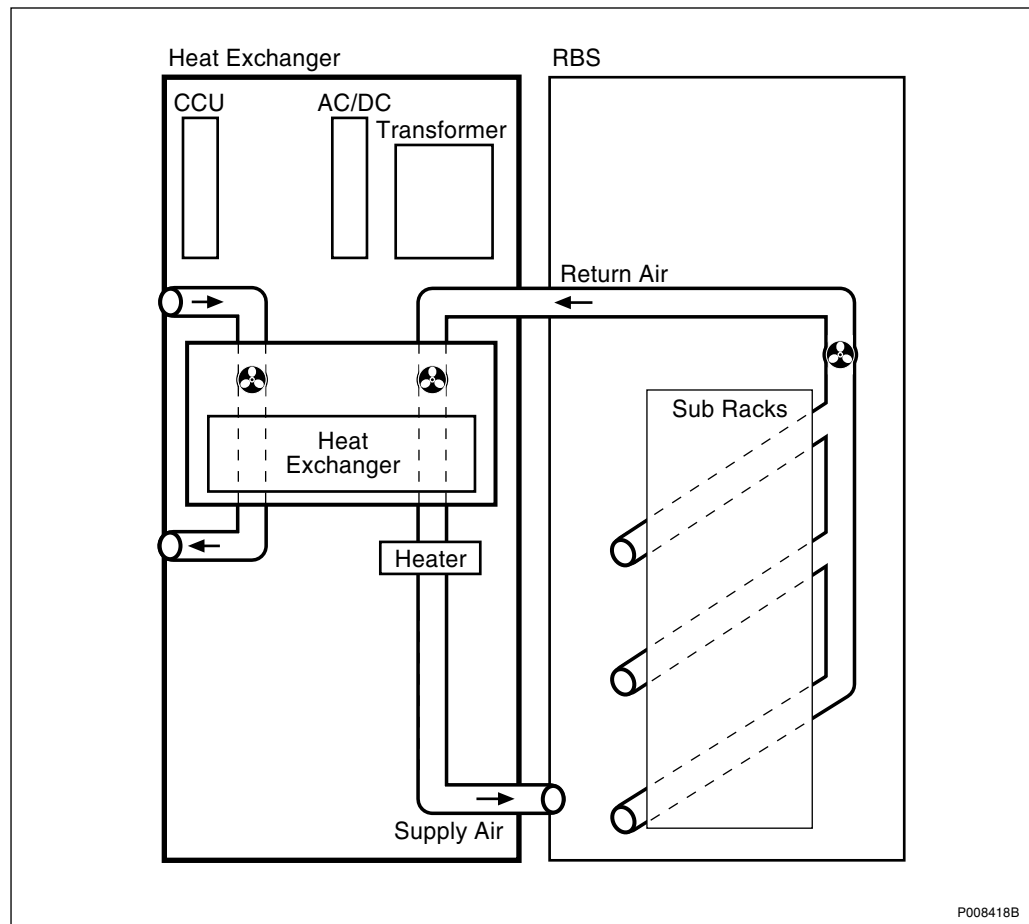

Figure 1 Block diagram

The Heat Exchanger Climate Unit consists of the following units:

- Heat Exchanger
- Heater
- Climate Control Unit (CCU)
- AC/DC Converter
- Transformer

### 4.1 Heat Exchanger

The heat exchanger consists of a cross-flow heat exchanger and internal and external air circuit fans.

Outside (ambient) air is forced through one side of the heat exchanger by DC-powered fans. There it cools the inside air which circulates through the other side of the heat exchanger.

Because ambient air is used on the 'cool' side of the heat exchanger, cooling capacity is limited to the temperature outside the cabinet. If the ambient temperature is higher than the cabinet return air temperature, the external air circulation fan will stop to prevent the outside air warming the cabinet.

## 4.2 Heater

The heater is placed in the internal air circuit. It operates at cold start-up, heating the inside air when the temperature inside the cabinet is below +5°C. The heater is not normally at any point other than cold start-up.

The heater is powered by AC mains voltage and is controlled by the Climate Control Unit. Its two heating coils have a total capacity of 2 kW.

## 4.3 Climate Control Unit

The Climate Control Unit (CCU) is a processor-based plug-in unit, controlling and supervising the climate unit. The CCU provides the following main functions:

- Monitors internal and external temperatures
- Monitors and controls the internal and external fans
- Monitors and controls the compressor
- Monitors and controls the condensor fan
- Monitors and controls the heater
- Handles alarms
- Supervises Mains Voltage
- Tests the Heat Exchanger Climate Unit

### Parameters

The CCU has a set of default operating parameters, which can be overridden by loaded parameters. These are sent to the CCU through the EPC-bus. Parameters which can be changed are the following:

- Temperature range for linear speed control of internal fan
- Temperature range for linear speed control of external fan
- Temperature range for heater on and off

## **Backplane and Front Panel**

The backplane connectors contain the climate unit internal interfaces to DC power, AC power, fans, temperature sensors, and so on.

The front panel contains indicators, connectors for the EPC bus and for test and control.

### **4.4 AC/DC Converter**

The AC/DC converter is used when +24 V DC supply is shut off. It changes the mains voltage to +24 V DC, to supply the internal air circuit fan, the external circuit fan in the heat exchanger, and the CCU.

### **4.5 Autotransformer**

The transformer converts different AC mains input voltages to 230 V AC for feeding the heater, the AC/DC converter and fans.

The transformer has windings for mains input voltages of 200, 208, 230, 240 and 250 V AC. The mains voltage is selected with the Voltage Selector Switch.

Connection to 120 V AC is made between phases with 208 V AC selected. Other voltages are connected between phase and neutral.

## **5 Interfaces**

### **5.1 Signal and Power**

The Heat Exchanger Climate Unit has the following external interfaces:

- DC power
- AC mains power
- EPC bus (on the CCU)
- Test and general signals (25-pole D-sub on the CCU)

## 5.2 Operator Interface

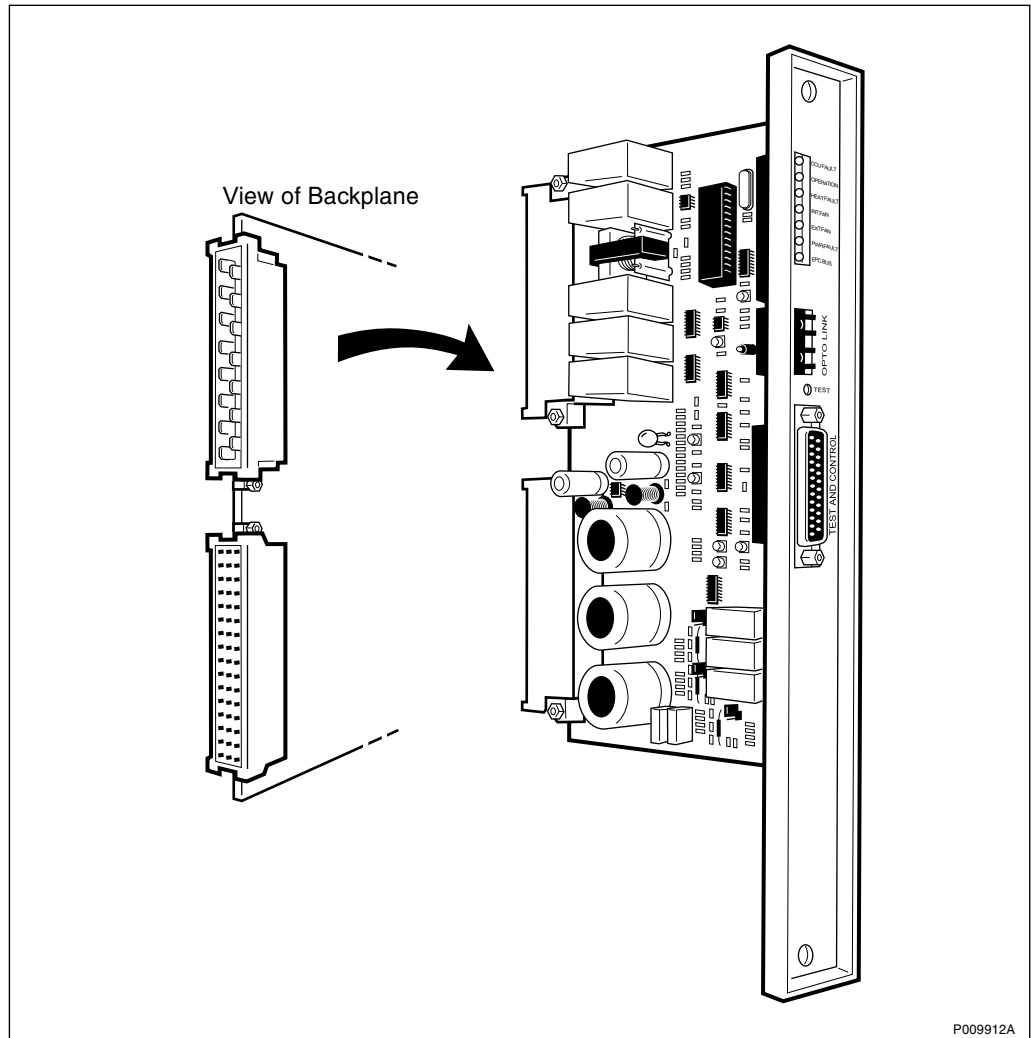

Figure 2 CCU

The CCU front panel has the following MMI interfaces:

- Test and general signals connector
- EPC bus connectors
- Test button
- Indicators

### Test and Control Connector

The test and general signals connector is a 25-pole D-sub connector.

## Indicators

Table 3 CCU front panel indicators

Indicator	Description	Colour
CCU FAULT	Fault	Red
OPERATION	Operational	Green
EPC BUS	EPC-bus fault	Yellow
HEAT FAULT	Heater fault	Yellow
HE.INT.FAN	Heat exchanger internal fan fault	Yellow
HE.EXT.FAN	Heat exchanger external fan fault	Yellow
PWR. FAULT	Power fault	Yellow

## EPC-bus Connectors

The EPC-bus is an optical communication bus used for RBS communication.

Table 4 EPC-bus connectors

Connector	Function
TD	Transmit
RD	Receive

## Test button

The test button on the front panel of the CCU activates the test function. After the test has been completed, the indicators will present the status for two minutes. No alarm is sent if there is a malfunction.

The total test time is approximately 6.5 minutes. During that time, the following are checked:

- External fan
- Internal fan
- Heater active
- Normal operation/failure information from the indicators

Last page, always an even numbered page

# IDM

Internal Distribution Module

## Unit Description

EN/LZT 720 0247 R1A

The Distribution Module (IDM) distributes +24 V DC to all DC powered units in the RBS.

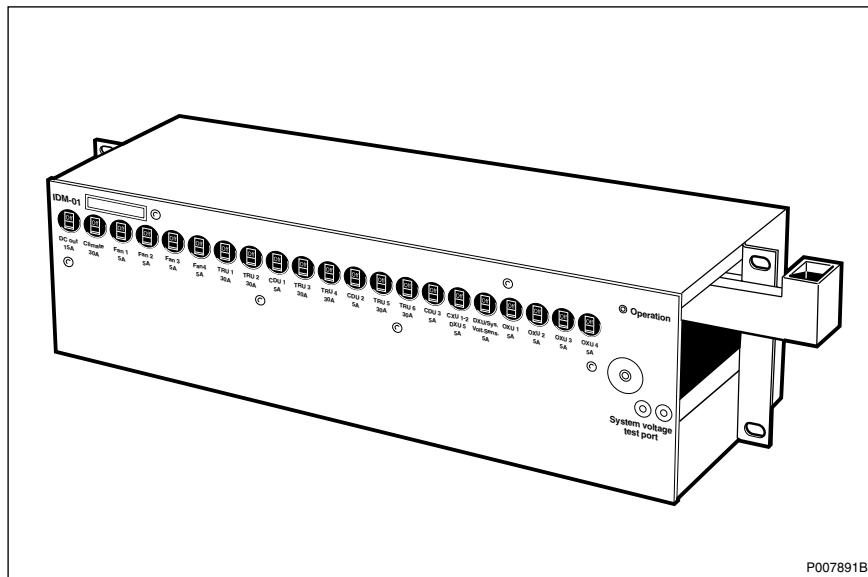

## Contents

<b>1</b>	<b>Product Overview</b>	<b>3</b>
1.1	Main Functions	3
<b>2</b>	<b>Dimensions</b>	<b>3</b>
<b>3</b>	<b>Function Description</b>	<b>3</b>
<b>4</b>	<b>Interface</b>	<b>4</b>
4.1	Signal and Power Interface	4
4.2	Operator Interface	5



# 1 Product Overview

The Internal Distribution Module distributes +24 V DC to all DC powered units in the RBS. Distribution circuits are protected by circuit breakers.

## 1.1 Main Functions

The IDM consists of a unit with 21 circuit breakers, four PSU cables and connectors to the different DC powered units.

# 2 Dimensions

The IDM has the following dimensions:

*Table 1 Dimensions*

Height	Width	Depth	Weight
133 mm	483 mm	80 mm	5 kg

# 3 Function Description

The IDM has the following external interfaces:

- Four PSU cables
- Battery connection (positive)
- Battery connection (negative) and earth connection
- System voltage test port
- ESD wrist-strap connector
- Power distribution connectors (*see table below*)

## 4 Interface

### 4.1 Signal and Power Interface

#### Input Data

*Table 2 Input data*

<b>Nominal input voltage range</b>	24 V DC
<b>Input voltage</b>	+20.0 – +29.0 V DC
<b>Non-destructive range</b>	0.0 – +32.0 V DC
<b>Input power</b>	4800 W

#### Output Data

Maximum voltage drop from the input to the output of the IDM is 0.3 V DC.

*Table 3 Circuit breaker capacity*

<b>Circuit breaker</b>	<b>Capacity</b>	<b>Quantity</b>
CXU 1 – 2, OXU 5	5A	1
Fan 1 – 4	5A	4
OXU 1 – 4	5A	4
DXU	5A	1
CDU 1 – 3	5A	3
DC out	15A	1
TRU 1 – 6	30A	6
Climate unit	30A	1

## Power Distribution Connectors

Table 6 Connectors

Connector	Function
P3	DC out
P4	Climate unit
P5	Fan 1 – 4
P6	TRU 1
P7	TRU 2
P8	CDU 1
P9	TRU 3
P10	TRU 4
P11	CDU 2
P12	TRU 5
P13	TRU 6
P14	CDU 3
P15	CXU 1
P16	CXU 2
P17	OXU 5
P18	DXU/System voltage sensor/OXU 1 – 4
P19	Test connector
P20	Indicator

## 4.2 Operator Interface

### Indicator

Table 7 Indicator

Indicator	Colour
Operational	Green



# PSU AC

Power Supply Unit

## Unit Description

EN/LZT 123 0249 R1A

The Power Supply Unit (PSUs) constantly regulate and deliver 1200 W power over the whole output range from 22 to 29 V DC.

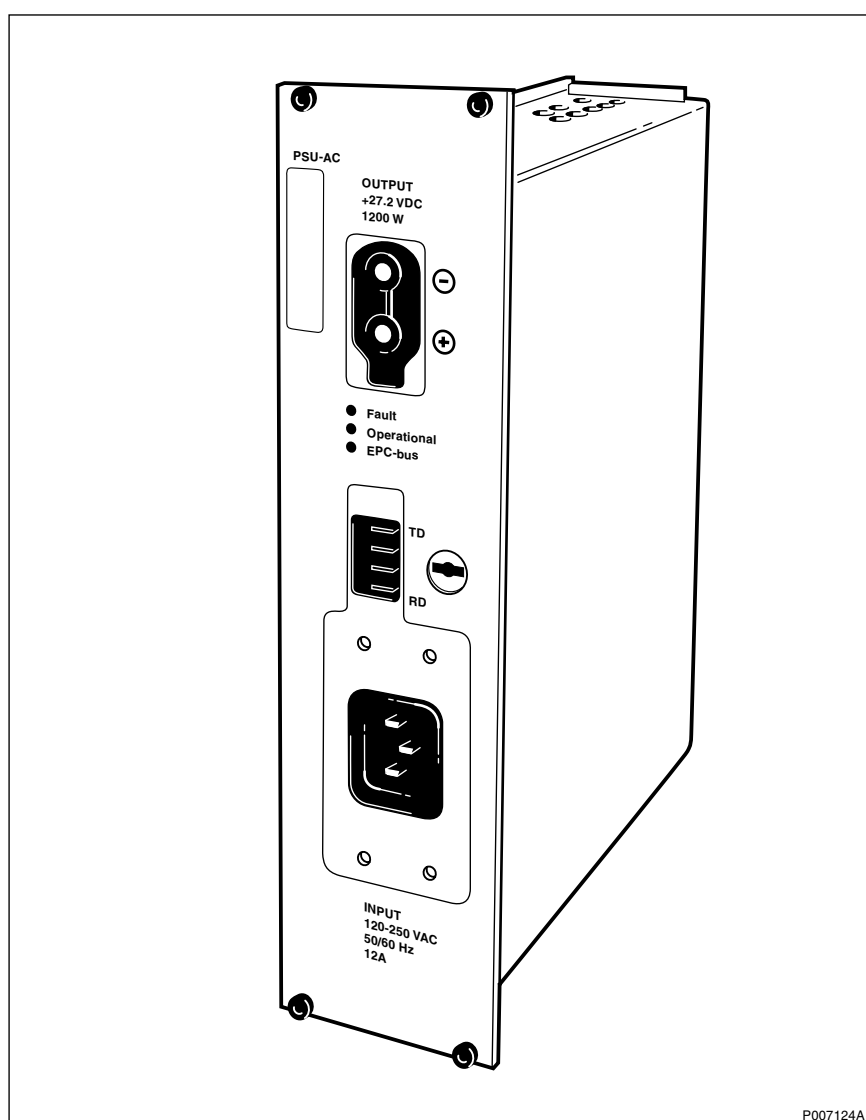

## Contents

<b>1</b>	<b>Product Overview</b>	<b>3</b>
1.1	Main Functions	3
1.2	Variants	3
<b>2</b>	<b>Dimensions</b>	<b>3</b>
<b>3</b>	<b>Power Consumption and Heat Generation</b>	<b>3</b>
<b>4</b>	<b>Function Description</b>	<b>4</b>
4.1	Input filter (EMC filter)	4
4.2	Bridge	4
4.3	Boost converter	4
4.4	DC/DC converter	5
4.5	Output filter (EMC filter)	5
4.6	Control and supervision circuits	5
<b>5</b>	<b>Interfaces</b>	<b>6</b>
5.1	Signal and Power Interfaces	7

# 1 Product Overview

The PSU rectifies the incoming AC power to the regulated DC voltage required.

## 1.1 Main Functions

The PSU AC does the following:

- Communicates with the DXU
- Handles alarms
- Adjusts voltage
- Provides power limitation

## 1.2 Variants

PSU 1200 W is available in two versions: PSU 230 AC and PSU -48 DC.

# 2 Dimensions

The PSU AC has the following physical characteristics.

*Table 1 PSU AC dimensions*

Height	Width	Depth	Weight
262 mm	61 mm	225 mm	3.3 kg

# 3 Power Consumption and Heat Generation

*Table 2 Power consumption and heat generation*

Max power consumption	Max heat generation
1446 V A	246 W

## 4 Function Description

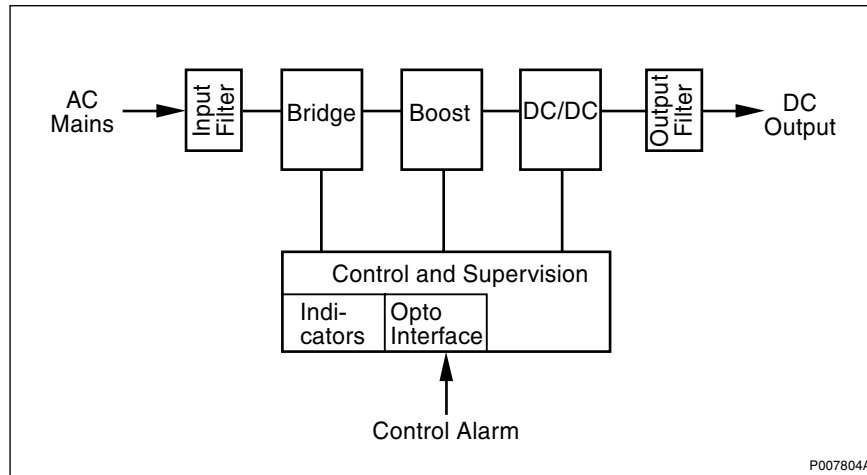

The PSU AC consists of the following main units:

- Input filter (EMC filter)
- Bridge
- Boost converter
- DC/DC converter
- Output filter (EMC filter)
- Control and supervision circuits

### 4.1 Input filter (EMC filter)

The incoming sine voltage first passes through an internal fuse and then the input filter, where it is filtered to prevent unwanted signals from being radiated from the PSU.

### 4.2 Bridge

The bridge rectifies the incoming AC.

### 4.3 Boost converter

The boost converter draws a sinusoidal input current in phase with the input voltage, enabling the power supply to have a high power factor and low distribution on input current. The output from the boost converter is 400 V DC.



#### **4.4 DC/DC converter**

The DC/DC Converter is a phase-shifted, soft-switched, full-bridge converter that converts the incoming 400 V DC to 24 V DC output voltage.

The output provides constant power regulation, rather than the more common current limited, and delivers 1200 W over the whole output range from 22 to 29 V DC.

#### **4.5 Output filter (EMC filter)**

The output voltage is filtered to prevent unwanted signals from being radiated from the PSU.

#### **4.6 Control and supervision circuits**

The control and supervision circuits support:

- Load sharing between parallel units
- Remote on/off
- Alarms

The output voltage can be adjusted between 22 to 29 V DC. The control and supervision is achieved through an optical signal interface connector on the front of the PSU.

# 5 Interfaces

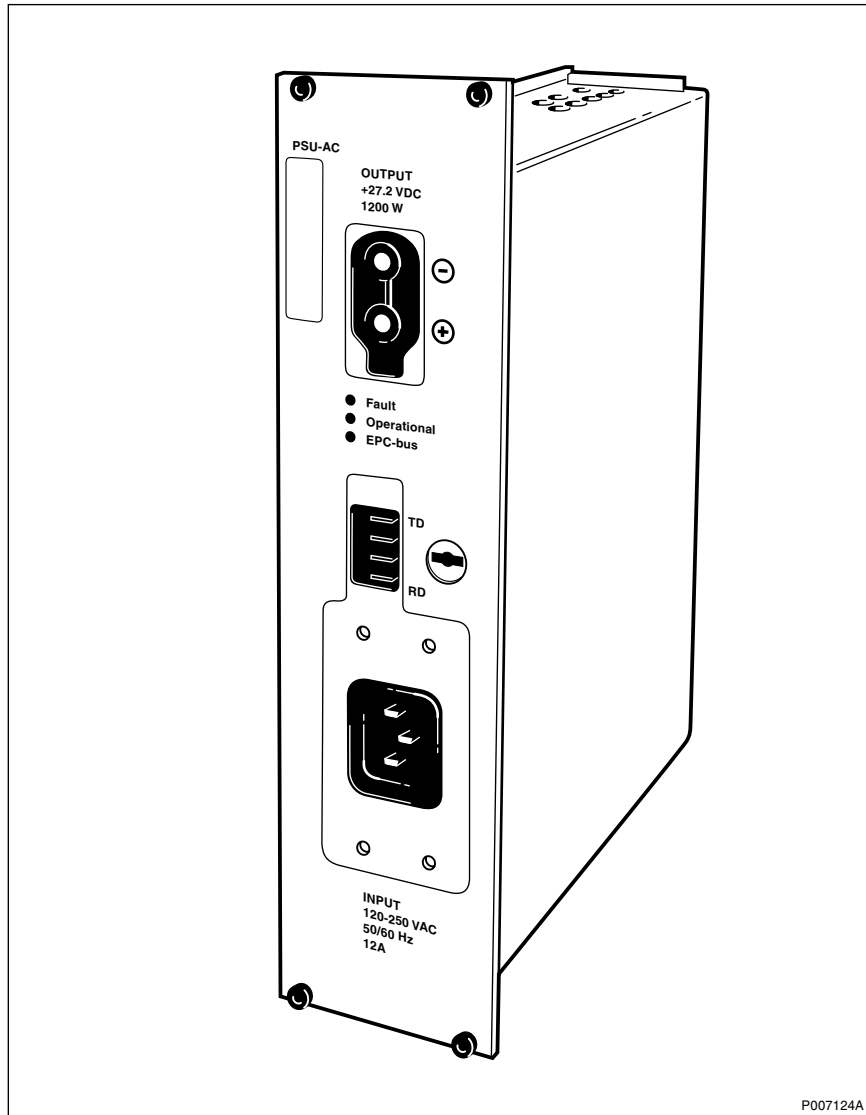

Figure 1 Interfaces

## 5.1 Signal and Power Interfaces

### Input Data

Table 3 Input data

<b>Nominal input voltage</b>	120 to 250 V AC <sup>(1)</sup>
<b>Variation input voltage</b>	108 <sup>(1)</sup> to 275 V AC
<b>Frequency</b>	45 – 65 Hz
<b>Current</b>	< 8A at 180 – 275 V AC) < 12 A (at 108 – 140 V AC)
<b>Inrush current</b>	< 30 A peak
<b>Internal fuse</b>	15 A (slow)
<b>Efficiency</b>	>83%
<b>Power factor</b>	cos $\phi$ > 0.95
<b>Non-destructive voltage Pulses &lt; 20 ms</b>	0 – 300 V AC 300 V AC

(1) Not all base stations are prepared for 250 V AC

### Output Data

Table 4 Output data

<b>Nominal output data</b>	+24 V DC
<b>Present output voltage</b>	+27.2 $\pm$ 0.1 V DC
<b>Voltage range</b>	+22.0 to +29.0 V DC
<b>Output power (108 – 275 V)</b>	1200 W
<b>Output power (90 – 108 V)</b>	1000 W
<b>Output current at 27.2 V DC</b>	36.8 A at 90 – 108 V AC 44.1 A at 108 – 275 V AC

**Note:** The PSU AC does not have any backplane connections.

## Indicators

*Table 5 Indicators*

<b>Indication</b>	<b>Colour</b>
Fault	Red
Operational	Green
EPC Bus Fault	Yellow

# PSU DC

## Power Supply Unit

### Description

The PSU DC converts incoming voltage ranging from -39 V to -72 V DC to the regulated DC voltage that is required.

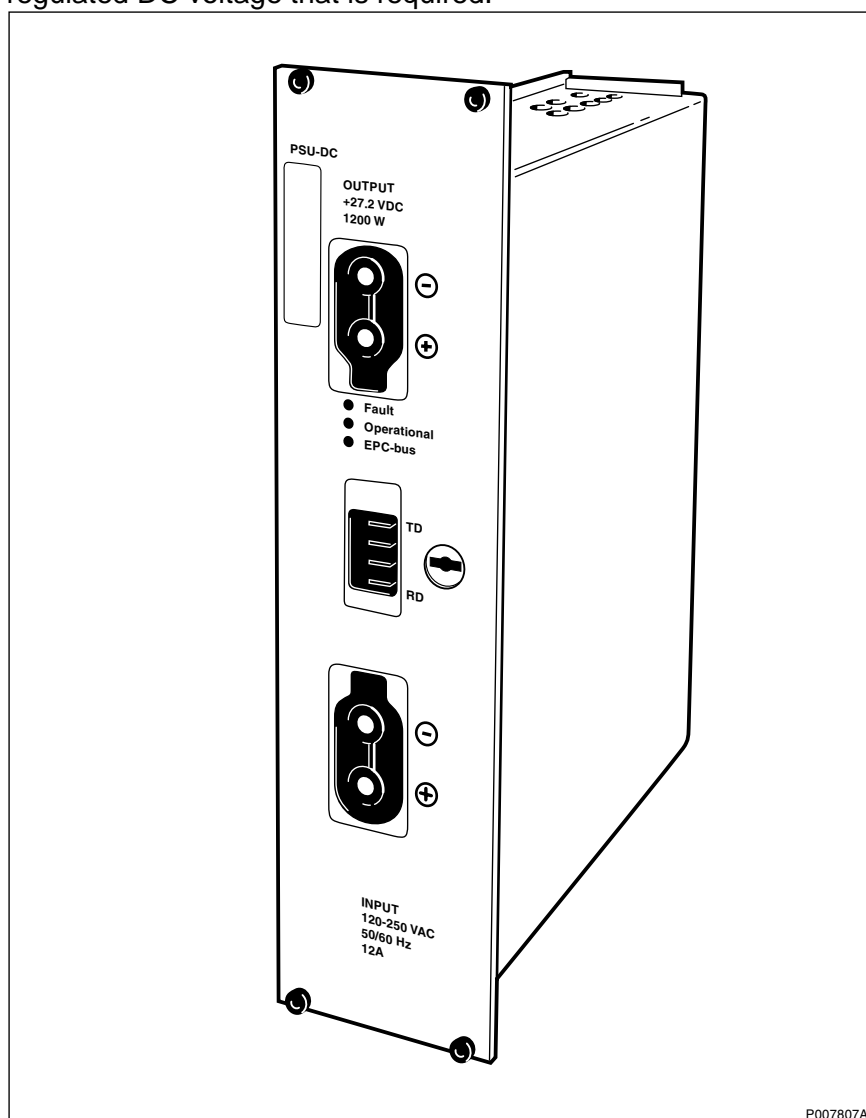

## Contents

<b>1</b>	<b>Product Overview</b>	<b>3</b>
1.1	Main functions	3
<b>2</b>	<b>Dimensions</b>	<b>3</b>
<b>3</b>	<b>Power Consumption and Heat Generation</b>	<b>3</b>
<b>4</b>	<b>FunctionDescription</b>	<b>4</b>
4.1	Input filter	4
4.2	DC/DC Converter	4
4.3	Output filter (EMC filter)	5
4.4	Control and supervision circuits	5
<b>5</b>	<b>Interface</b>	<b>5</b>
5.1	Signal and Power Interface	5
5.2	Operator Interface	6

# 1 Product Overview

The PSU DC converts incoming voltage ranging from -39 V to -72 V DC to the regulated DC voltage that is required.

## 1.1 Main functions

The PSU DC has the following functions:

- Communication
- Handles alarms
- Adjusts voltage
- Provides power limitation

# 2 Dimensions

*Table 1 PSU DC Dimensions*

<b>Height</b>	<b>Width</b>	<b>Depth</b>	<b>Weight</b>
262 mm	61 mm	225 mm	3.1 kg

# 3 Power Consumption and Heat Generation

*Table 2 Power consumption and heat generation*

<b>Max power consumption</b>	<b>Max heat generation</b>
1411 W	211 W

## 4 FunctionDescription

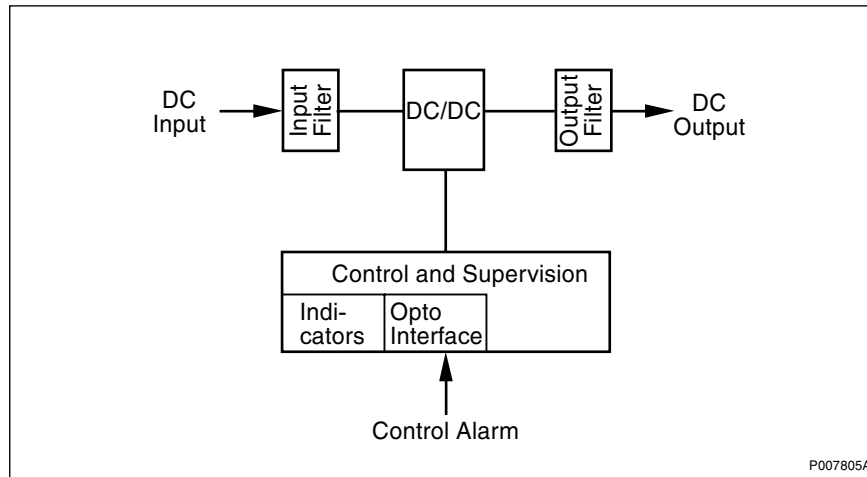

Figure 1 PSU –DC block diagram

The PSU DC consists of the following main units:

- Input filter (EMC filter)
- DC/DC Converter
- Output filter (EMC filter)
- Control and supervision circuits

### 4.1 Input filter

The incoming voltage passes through the input filter first, where it is filtered to prevent unwanted signals from being radiated from the PSU.

### 4.2 DC/DC Converter

The DC/DC converter is a phase-shifted, full-bridge converter that converts the DC into a square wave. This is then fed into the primary side of the transformer. The converter limits the current in case of overload.

In the transformer, the voltage is converted to a 24 V AC square wave, and this wave is rectified to DC through a diode rectifier.

The output provides constant power regulation, rather than the more common current limited, and delivers 1200 W over the whole output voltage range from 22 to 29 V DC.



### 4.3 Output filter (EMC filter)

The output filter filters the output voltage to prevent unwanted signals from being radiated from the PSU.

### 4.4 Control and supervision circuits

The control and supervision circuits support:

- Load sharing between parallel units
- Remote on/off
- Alarms

The output voltage can be adjusted between 22 V to 29 V DC. The control and supervision is achieved through an optical signal interface connector on the front of the PSU.

## 5 Interface

### 5.1 Signal and Power Interface

#### Input Data

Table 3 Input data

<b>Nominal input voltage</b>	(-48) – (-60) V DC
<b>Permitted Variation input voltage</b>	(-39) – (-72) V DC
<b>Input current</b>	< 36 A
<b>Inrush current</b>	< 200 A
<b>Efficiency</b>	> 85%
<b>Non-destructive voltage</b>	0 – (-75) V DC

## Output Data

Table 4 Output data

<b>Nominal output voltage</b>	+24 V DC
<b>Factory set value</b>	+27.2 ± 0.1 V DC
<b>Voltage range</b>	22.0 – 29.0 V DC
<b>Output power</b>	1200 W
<b>Output current at 27.2</b>	44.1 A
<b>Output current at short circuit</b>	< 60 A

## 5.2

### Operator Interface

The PSU has the following interfaces, all located on the front panel:

- Power supply AC
- Power control bus (opto)

### Indicators

Table 5 PSU DC Indicators

<b>Indication</b>	<b>Colour</b>
Fault	Red
Operational	Green
EPC Bus	Yellow

# TMA-CM

Tower Mounted Amplifier - Control Module

## Unit Description

EN/LZT 720 0250 R1A

The Tower Mounted Amplifier Control Module (TMA-CM), together with the bias injectors, supply power to the TMA. It also monitors and controls the TMAs.

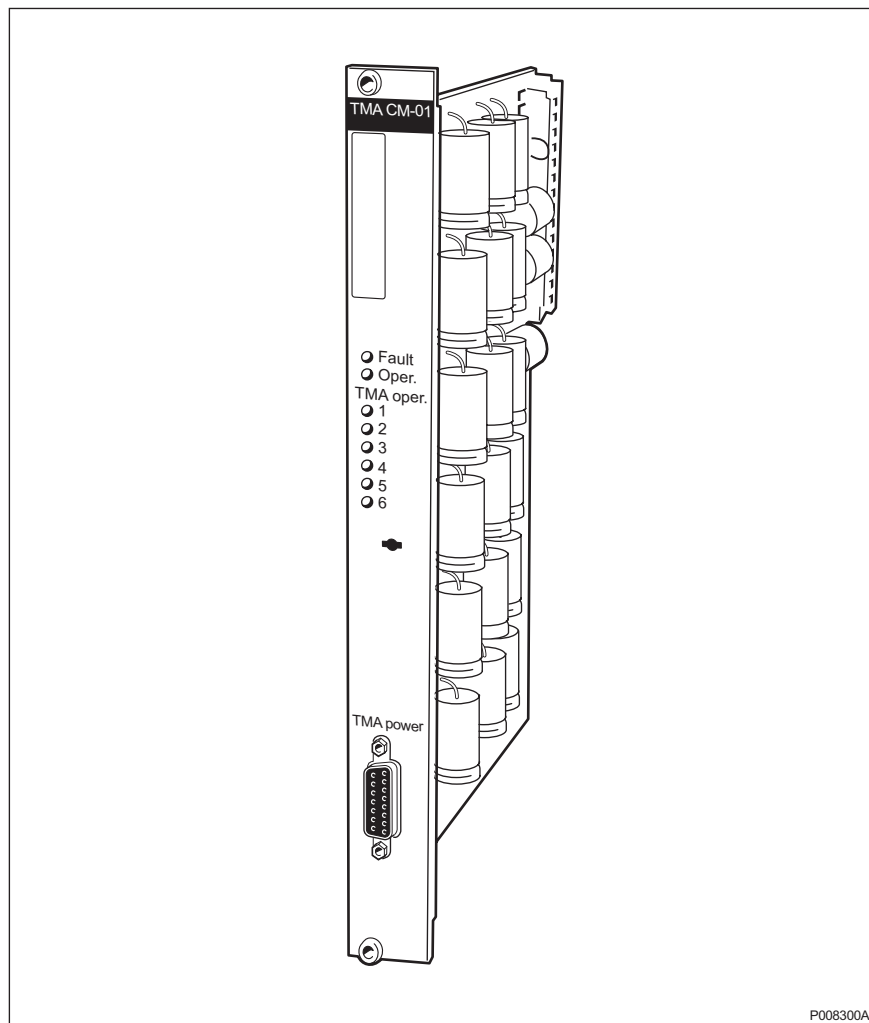

## Contents

<b>1</b>	<b>Product Overview</b>	<b>3</b>
1.1	Main Functions	3
<b>2</b>	<b>Function Description</b>	<b>4</b>
<b>3</b>	<b>Interface</b>	<b>5</b>
3.1	Signal and Power Interface	5
3.2	Operator Interface	5

# 1 Product Overview

## 1.1 Main Functions

The TMA-CM has the following functions:

- Supplies power to the TMAs through bias injectors
- Monitors the TMAs
- Controls the TMAs
- Supplies power for up to six TMAs
- Controls TMA (on/off)
- Measures DC and voltage
- Supervises indicators
- Provides short circuit protection
- Supervises cables

## 2 Function Description

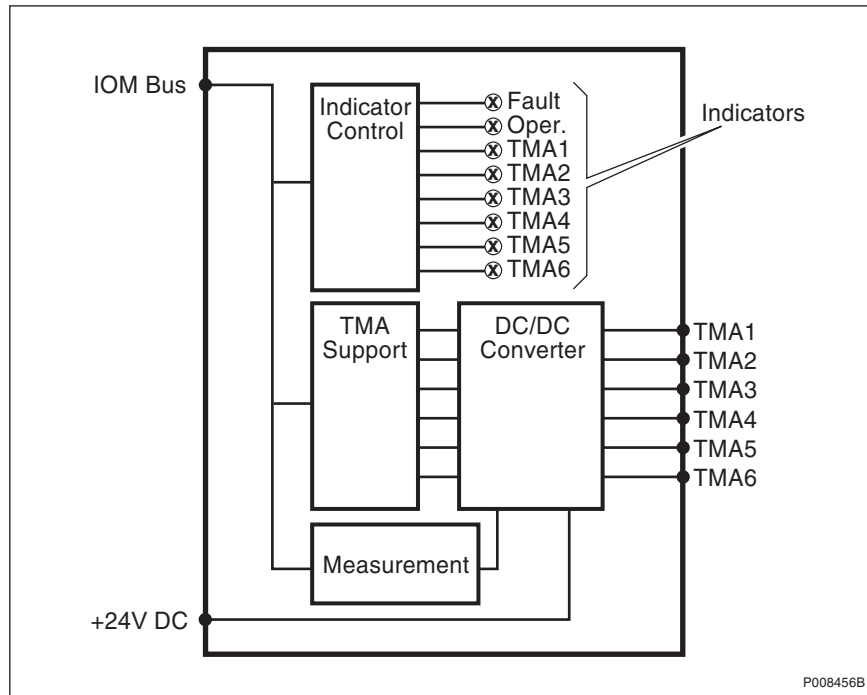

*Figure 1 Block diagram*

The TMA-CM supplies up to six TMAs with 15 V DC and maximum 500 mA to each TMA. The power output is a 15-pole d-sub connector on the front of the TMA-CM. A TMA consumes in general 70 – 200 mA.

The TMAs can be individually switched on and off by commands from the DXU.

The current and voltage to each TMA is measured, and an alarm is generated if the values are outside specified values, indicating that a TMA is not working properly. The alarm is transmitted to the DXU on the IOM bus.

The TMA is always used together with its connection cable and connection plate for bias injectors. The connection plate contains filtering equipment.

An indicator on the front panel is illuminated for each TMA in operational mode. Whether an indicator is illuminated depends also on the actual configuration, see Chapter Radio Configurations, RBS 2106 and RBS 2206.

If the TMA or the feeder cable short-circuits, the TMA-CM limits the current to 500 mA.

The power cable to the bias injector is supervised and an alarm is generated if the cable is not connected. The alarm is transmitted on the IOM bus.

## 3 Interface

### 3.1 Signal and Power Interface

Table 1 Input data

<b>Nominal input voltage</b>	+24 V DC
<b>Input voltage range</b>	+20.0 – 29.5 V DC
<b>Non-destructive voltage</b>	0 – +32 V DC
<b>Maximum input power</b>	60 W

Table 2 Output data

<b>Voltage per output (1 – 6)</b>	+15 V DC <sup>(1)</sup>
<b>Current per output</b>	Maximum 500 mA

(1) Tolerance  $\pm 1.0$  V at TMA current 0 – 300 mA.  
Tolerance  $\pm 1.5$  V at TMA current 300 – 500 mA.

### 3.2 Operator Interface

The TMA-CM has the following external interfaces:

- Power in (+24 V DC)
- IOM bus
- TMA power connector

#### Indicators

The TMA-CM has eight indicators on the front panel that shows the status of each TMA and the status of the TMA-CM.

The indicators Fault and Operational indicate the status of the TMA-CM only, not the status of the TMAs.

*Table 3 Indicators*

<b>Indicator</b>	<b>Colour</b>
Fault	Red
Operational	Green
TMA1 operating	Green
TMA2 operating	Green
TMA3 operating	Green
TMA4 operating	Green
TMA5 operating	Green
TMA6 operating	Green



# RBS 2000 Glossary

This document provides a glossary of terms and abbreviations used in RBS 2000 Customer Product Information (CPI).

# Contents

<b>1</b>	<b>Terms and Abbreviations</b>	<b>3</b>
----------	--------------------------------	----------

# 1 Terms and Abbreviations

This glossary lists abbreviations and acronyms used in texts dealing with RBS 2000 cabinets. Some basic terms and acronyms needed for cross-reference are included in the list.

An arrow  $\Rightarrow$  is used to indicate a reference to another entry in the list.

<b>1-P</b>	One-Pair connection with echo cancellation (= two wires)
<b>2-P</b>	Two-Pair connection with echo cancellation (= four wires)
<b>AAU</b>	Active Antenna Unit
<b>Abis</b>	GSM interface standard defining attributes of the communication between the BSC and the BTS.
<b>AC</b>	Alternating Current
<b>ACB</b>	Alarm Collection Board
<b>ACCU</b>	Alternating Current Connection Unit
<b>ACCU-CU</b>	ACCU Connection Unit
<b>ACCU-DU</b>	ACCU Distribution Unit
<b>A/D converter</b>	Analog to Digital converter
<b>AFS</b>	AMR Full-rate speech
<b>AGW</b>	Abis Gateway
<b>AHR</b>	AMR Half-rate speech
<b>Air conditioner</b>	One version of the climate unit (Active cooler)
<b>AIS</b>	Alarm Indication Signal
<b>ALBO</b>	Automatic Line Build Out
<b>ALNA</b>	Antenna Low Noise Amplifier
<b>ALPU</b>	Antenna Lightning Protection Unit
<b>AMR</b>	Adaptive Multi-Rate
<b>AO</b>	Application Object

<b>ARAE</b>	Antenna Related Auxiliary Equipment
<b>ARFCN</b>	Absolute Radio Frequency Channel Number
<b>ARP</b>	Antenna Reference Point
<b>ARU</b>	Active Replaceable Unit
<b>ASIC</b>	Application Specific Integrated Circuit
<b>Astra</b>	ASIC in the TRU
<b>ASU</b>	Antenna Sharing Unit
<b>AT</b>	Alphanumeric Terminal
<b>ATRU</b>	Adaptive Transceiver Unit
<b>ATSR</b>	Air Time Slot Resource
<b>AU</b>	Antenna Unit GSM 900 = CEU + Passive Antenna GSM 1800/1900 = AAU
<b>BALUN</b>	BALance and UNbalance transformer
<b>Batt</b>	Battery
<b>BB</b>	Battery Box
<b>BBS</b>	Battery Back-up System
<b>BCCH</b>	Broadcast Control CHannel Downlink only broadcast channel for broadcast of general information at a base station, on a base station basis.
<b>BCS</b>	Block Check Sequence
<b>BDM</b>	Battery Distribution Module The BDM is an IDM with a battery and a local processor.
<b>BER</b>	Bit Error Rate
<b>BFF</b>	Bit Fault Frequency
<b>BFI</b>	Bad Frame Indication

<b>BFU</b>	Battery Fuse Unit
<b>Bias injector</b>	A unit which injects DC power into the coaxial cable to feed the TMA. Isolates the DC power from the RF signal fed to the CDU.
<b>Bm</b>	Denotes a full-rate traffic channel
<b>BPC</b>	Basic Physical Channel  Denotes the air interface transport vehicle formed by repetition of one time slot on one or more radio frequency channels.
<b>BS</b>	Base Station
<b>BSC</b>	Base Station Controller  GSM network node for control of one or more BTSs.
<b>BSCSim</b>	Base Station Controller Simulator
<b>BSS</b>	Base Station System  GSM network logical unit comprising one BSC and one or more BTSs.
<b>BTS</b>	Base Transceiver Station  GSM network unit operating on a set of radio frequency channels in one cell.
<b>burst</b>	A portion of digital information, the physical content, that is transferred within the time interval of one time slot.
<b>cabinet</b>	The physical housing of a base station
<b>Cascade connections</b>	Connection of several cabinets by the PCM cable. Similar to serial connection.  ⇒ Cascading
<b>Cascading</b>	Connection of several cabinets by the PCM cable. Similar to serial connection.  ⇒ Cascade connections

<b>CBCH</b>	Cell Broadcast CHannel  This is a downlink only channel used by the GSM defined SMSCB function.
<b>CCCH</b>	Common Control CHannel  Channel combining the following common control channels: <ul style="list-style-type: none"><li>• PCH Paging CHannel</li><li>• RACH Random Access CHannel</li><li>• AGCH Access Grant CHannel</li></ul>
<b>CCU</b>	Climate Control Unit
<b>CDU</b>	Combining and Distribution Unit
<b>CE</b>	Conformité Européenne
<b>cell</b>	An area of radio coverage identified by the GSM network by means of the cell identity.
<b>CEU</b>	Coverage Extension Unit
<b>CF</b>	Central Functions
<b>channel</b>	The common term channel denotes the virtual connection, consisting of physical and logical channels, between BSS and MS, during a call in progress.  ⇒ Logical Channel ⇒ Physical Channel
<b>Channel Combination</b>	A physical channel on an air interface carrying a defined set of logical channels.
<b>Channel group</b>	A channel group is a group of dedicated logical channels to a specific MS.
<b>CM</b>	Control Module (for TMA)
<b>CMD</b>	Digital Radio Communication Tester

<b>CMRU</b>	Central Main Replaceable Unit.  The RBS is physically connected to the Base Station Controller (BSC) via the CMRU. There is only one CMRU in each RBS.
<b>Macro</b>	CMRU = DXU
<b>Micro</b>	CMRU = The whole RBS
<b>CNU</b>	Combining Network Unit
<b>Compr</b>	Compressor
<b>CON</b>	LAPD concentrator  LAPD concentration is used to reduce the number of required physical links between the BSC and BTS.
<b>Config</b>	Configuration
<b>Co-siting</b>	Co-siting is the operation of radio equipment from more than one mobile telephone system and/or frequency on the same site sharing common equipment.
<b>CPI</b>	Communication and Power Interface
<b>CPI</b>	Customer Product Information
<b>CPU</b>	Central Processing Unit
<b>CRC</b>	Cyclic Redundancy Check
<b>CS</b>	Coding Scheme
<b>CSA</b>	Canadian Standards Association
<b>CSES</b>	Consecutive Severely Errored Second
<b>CSU</b>	Channel Service Unit
<b>CU</b>	Combining Unit (RU in CDU_D)
<b>CXU</b>	Configuration Switch Unit
<b>Dannie</b>	ASIC in the TRU
<b>DB</b>	DataBase
<b>DC</b>	Direct Current

<b>DCC</b>	Digital Cross Connector
<b>DCCH</b>	Dedicated Control CHannel
	Dedicated control channels carry signalling data.
<b>DCCU</b>	DC Connection Unit
<b>ddTMA</b>	dual duplex Tower Mounted Amplifier
	This type needs only one combined TX/RX feeder from the BTS to the TMA. ⇒ dTMA ⇒ rTMA ⇒ TMA ⇒ BTS
<b>DF</b>	Distribution Frame
<b>DF</b>	Disturbance Frequency
<b>DFU</b>	Distribution and Fuse Unit
<b>DIP</b>	Digital Path
	The name of the function used for supervision of the connected PCM lines.
<b>Dixie</b>	ASIC in the TRU
<b>DM</b>	Degraded Minute
<b>DM</b>	Distribution Module
<b>DMRU</b>	Distributed Main Replaceable Unit
	If a Main RU is subordinated to the CMRU, it is said to be distributed.
<b>downlink</b>	Signalling direction from the system to the MS.
<b>DP</b>	Digital Path
<b>DP</b>	Distribution Panel
<b>DPX</b>	Duplexer
<b>DS1</b>	Digital Signal level 1 (1544 kbit/s)
<b>DSP</b>	Digital Signal Processor
<b>DT</b>	Data Transcript
<b>DTE</b>	Data Terminal Equipment



<b>DTF</b>	Distance To Fault
<b>dTMA</b>	duplex TMA  dTMA is similar to the old ALNA except for different characteristics. ⇒ ddTMA ⇒ rTMA ⇒ TMA
<b>dTRU</b>	double TRansceiver Unit
<b>DU</b>	Distribution Unit (RU in CDU-D)
<b>DUT</b>	Device Under Test
<b>DX</b>	Direct Exchange
<b>DXB</b>	Distribution Switch Board
<b>DXC</b>	Digital Cross Connector
<b>DXU</b>	Distribution Switch Unit
<b>DXX</b>	Ericsson Cellular Transmission System including NMS
<b>E1</b>	Transmission standard, G.703, a 2048 kbit/s PCM link
<b>E-GSM</b>	Extended GSM
<b>EACU</b>	External Alarm Connection Unit
<b>EC1</b>	External Condition Map Class 1
<b>EC2</b>	External Condition Map Class 2
<b>ECU</b>	Energy Control Unit
<b>EDGE</b>	Enhanced Data rate for Global Evolution
<b>EDGE dTRU</b>	EDGE double TRansceiver Unit  ⇒ EDGE
<b>EDT</b>	Electrical Down Tilt
<b>EEPROM</b>	Electrically Erasable Programmable Read-Only Memory
<b>EIRP</b>	Effective Isotropic Radiated Power
<b>EMC</b>	ElectroMagnetic Compatibility
<b>EMF</b>	ElectroMotive Force

<b>EMF</b>	ElectroMagnetic Field
<b>EMI</b>	Electromagnetic Interference
<b>ENV</b>	Environmental
<b>EOC</b>	Embedded Operations Channel
<b>EPC</b>	Environmental and Power Control
<b>ES</b>	Errored Second
<b>ESB</b>	External Synchronization Bus
<b>ESD</b>	ElectroStatic Discharge
<b>ESF</b>	Extended Superframe Format
<b>ESO</b>	Ericsson Support Office
<b>ETS</b>	European Telecommunication Standard
<b>EXT</b>	External
<b>FACCH</b>	Fast Associated Control CHannel Main signalling channel in association with a TCH.
<b>FCC</b>	Federal Communications Commission
<b>FCCH</b>	Frequency Correction CHannel
<b>FCOMB</b>	Filter COMBiner
<b>FCU</b>	Fan Control Unit
<b>FDL</b>	Facility Data Link
<b>FDU</b>	Feeder Duplexer Unit
<b>FER</b>	Frame Erasure Ratio
<b>FIU</b>	Fan Interface Unit
<b>FS</b>	Function Specification
<b>FSC</b>	Field Support Centre
<b>FU</b>	Filter Unit (RU in CDU-D)
<b>FUd</b>	Filter Unit with duplexer (RU in CDU-D)

<b>FXU</b>	Future Expansion Unit
<b>G01</b>	MO model for RBS 200
<b>G12</b>	MO model for RBS 2000
<b>G.703</b>	Physical/electrical characteristics of hierarchical digital interfaces, as defined by the ITU.
<b>G.704</b>	Synchronous frame structures used at 1544, 6312, 2048, 8448 and 44 736 kbit/s, as defined by the ITU.
<b>GPRS</b>	General Packet Radio Services
<b>GS</b>	General Specification
<b>GSL</b>	GPRS Signalling Link
<b>GSM</b>	Global System for Mobile communications  International standard for a TDMA digital mobile communication system. Originally, GSM was an abbreviation for Group Special Mobile, which is a European mobile telecommunication interest group, established in 1982.
<b>GSM 800</b>	GSM system 800 MHz (generic)
<b>GSM 900</b>	GSM system 900 MHz (generic)
<b>GSM 1800</b>	GSM system 1800 MHz (generic)
<b>GSM 1900</b>	GSM system 1900 MHz (generic)
<b>HCE</b>	HDSL Central Equipment
<b>HCOMB</b>	Hybrid COMBiner
<b>HDLC</b>	High level Data Link Control
<b>HDSL</b>	High bit rate Digital Subscriber Line
<b>Heat Exchanger</b>	A version of the climate unit
<b>HEU</b>	Heat Exchanger Unit
<b>HISC</b>	Highway Splitter Combiner
<b>HLIN</b>	High Level IN
<b>HLOUT</b>	High Level OUT

<b>HMS</b>	Heat Management System
<b>Hum</b>	Humidity
<b>HW</b>	HardWare
<b>HWU</b>	HardWare Unit
	An HWU consists of one or more SEs. An HWU is a functional unit within the RBS. The HWU is either active (equipped with a processor) or passive (without processor).
<b>I1A</b>	Internal Fault Map Class 1A
<b>I1B</b>	Internal Fault Map Class 1B
<b>I2A</b>	Internal Fault Map Class 2A
<b>IA</b>	Immediate Assignment
<b>IC</b>	Integrated Circuit
<b>ICMI</b>	Initial Codec Mode Indicator
<b>ID</b>	IDentification
<b>IDB</b>	Installation DataBase
<b>IDM</b>	Internal Distribution Module
<b>IEC</b>	International Electric Commission
<b>IF Box</b>	Interface Box
<b>IMSI</b>	International Mobile Subscriber Identity
<b>INIT</b>	Initial
<b>INT</b>	Internal
<b>IOG</b>	Input/Output Group
<b>IOM</b>	Internal Operation and Maintenance bus
<b>IR</b>	InfraRed
<b>IS</b>	Interface Switch
<b>IWD</b>	InterWork Description

<b>JTC</b>	Joint Technical Committee
<b>LAPD</b>	<p>Link Access Procedures on D-channel</p> <p>LAPD is the data link layer (layer 2) protocol used for communication between the BSC and the BTS on the Abis interface.</p> <p>Abis layer 2 is sometimes used synonymously with LAPD.</p>
<b>LBO</b>	Line Build Out
<b>LED</b>	Light Emitting Diode
<b>LLB</b>	Line Loop Back
<b>LNA</b>	Low Noise Amplifier
<b>Local bus</b>	The local bus offers communication between a central main RU (DXU) and distributed main RUs (TRU and ECU).
<b>Local mode</b>	When the RU is in Local mode, it is not communicating with the BSC.
<b>Local/Remote switch</b>	A switch used by the operator to order the RU to enter Local or Remote mode.
<b>LOF</b>	Loss Of Frame
<b>Logical Channel</b>	<p>A logical channel represents a specified portion of the information carrying capacity of a physical channel.</p> <p>GSM defines two major categories of logical channels:</p> <ul style="list-style-type: none"> <li>• TCHs – Traffic CHannels, for speech or user data</li> <li>• CCHs – Control CHannels, for control signalling</li> </ul> <p>⇒ Physical Channel ⇒ Channel Combination</p>
<b>Logical RU</b>	<p>A unit which can be referred to, but is not a single physical unit. There are three different kinds of logical RUs:</p> <ul style="list-style-type: none"> <li>• Antennas</li> <li>• Buses</li> <li>• Environment</li> </ul>

<b>LOS</b>	Loss Of Signal
<b>LVD</b>	Low Voltage Directive
<b>LVF</b>	Low Voltage Filter
<b>MAC</b>	Medium Access Controller
<b>MADT</b>	Mean Accumulated DownTime
<b>magazine</b>	A magazine is a reserved space in the cabinet, which may hold one or more RUs.
<b>Main RU</b>	Contains one or more processors, to which software can be downloaded from the BSC. A Main RU is either Central (CMRU) or Distributed (DMRU). A Main RU may or may not have a direct signalling link to the BSC.
<b>Main RU</b>	A main replaceable unit is a replaceable unit that contains one or more processors, to which software can be downloaded from the BSC.
<b>MCB</b>	MultiCasting Box
<b>MHS</b>	Modification Handling System Ericsson trouble report database
<b>MMI</b>	Man-Machine Interface
<b>MO</b>	Managed Object
<b>MR</b>	Measurement Receiver
<b>MRT</b>	Mean Repair Time
<b>MS</b>	Mobile Station
<b>MSC</b>	Mobile services Switching Centre GSM network unit for switching, routing and controlling calls to and from the Public Switched Telephone Network (PSTN) and other networks.
<b>MSTP</b>	Mobile Station Test Point
<b>MTBF</b>	Mean Time Between Failure
<b>MTBCF</b>	Mean Time Between Catastrophe Failure

<b>Multidrop</b>	Two or more RBSs connected in a chain to the same transmission system. All the relevant time slots are dropped out by each RBS. (This function is sometimes called cascading.)
<b>NCS</b>	National Colour System
<b>NEBS</b>	Network Equipment Building System
<b>NMS</b>	Ericsson Network Management System in DXX
<b>Nominal Power</b>	The nominal power is the power level defined when configuring the transceiver.
<b>N terminal</b>	Neutral terminal in an AC mains connection
<b>NTU</b>	Network Terminating Unit
<b>OL/UL</b>	Overlaid/Underlaid
<b>O&amp;M</b>	Operation and Maintenance  General term for activities such as configuration, utilization of channels (frequency bands), cell planning, system supervision, hardware and software maintenance, subscriber administration, and so on.
<b>OMC</b>	Operation and Maintenance Centre
<b>OML</b>	Operation and Maintenance Link  Layer 2 communication link for operation and maintenance services on Abis.
<b>OMT</b>	Operation and Maintenance Terminal  The OMT is a terminal that supports functions for handling the RBS on site. The terminal can be a portable PC.
<b>Operation</b>	Operation is the normal, everyday running of the RBS with full functions.
<b>OPI</b>	Operational Instructions
<b>OVP</b>	OverVoltage Protection
<b>OXU</b>	Space for Optional Expansion
<b>P-GSM</b>	Primary GSM

<b>PA</b>	Power Amplifier
<b>PAM</b>	Power Amplifier Module
<b>Passive RU</b>	A passive replaceable unit has a very low level of intelligence and is independent of the processor system.
<b>PBA</b>	Printed Board Assembly
<b>PBC</b>	Power and Battery Cabinet
<b>PC</b>	Personal Computer
<b>PCAT</b>	Product CATalogue  A web-based ordering system on Ericsson's Intranet.
<b>PCB</b>	Printed Circuit Board
<b>PCH</b>	Paging CHannel  Downlink only subchannel of CCCH for system paging of MSs.  ⇒ CCCH
<b>PCM</b>	Pulse Code Modulation
<b>PCU</b>	Packet Control Unit
<b>PDCH</b>	Packet Data Channel
<b>PE terminal</b>	Protective Earth terminal in an AC mains connection
<b>PFWD</b>	Power Forward
<b>Physical Channel</b>	An air interface physical channel carries one or more logical channels. A physical channel uses a combination of frequency and time division multiplexing and is defined as a sequence of radio frequency channels and time slots.  ⇒ TDMA frame ⇒ Logical channel
<b>PIN</b>	Personal Identification Number
<b>PLB</b>	Payload Loop Back



<b>PLMN</b>	Public Land Mobile Network  A network, established and operated by an administration or its licensed operator(s), for the specific purpose of providing land mobile communication services to the public. It provides communication possibilities for mobile users. For communication between mobile and fixed users, interworking with a fixed network is necessary.
<b>PPE</b>	Personal Protective Equipment
<b>PREFL</b>	Power Reflected
<b>PSA</b>	Power Supply Adapter
<b>PSTN</b>	Public Switch Telephone Network
<b>PSU</b>	Power Supply Unit
<b>PWU</b>	Power Unit
<b>RACH</b>	Random Access CHannel  Uplink only subchannel of CCCH for MS request for allocation of a dedicated channel.  ⇒ CCCH
<b>RAI</b>	Remote Alarm Indication
<b>RAM</b>	Random Access Memory
<b>RBER</b>	Radio Bit Error Ratio
<b>RBS</b>	Radio Base Station  All equipment forming one or more Ericsson base station.  ⇒ BTS
<b>RCB</b>	Radio Connection Box
<b>RD</b>	Receive Data
<b>Remote mode</b>	When the RU is in RU Remote mode, a link is established between the BSC and the Central Main RU (CMRU).

<b>RF</b>	Radio Frequency
<b>RFCH</b>	Radio Frequency CHannel
	A radio frequency carrier with its associated bandwidth.
<b>RFTL</b>	Radio Frequency Test Loop
<b>RLC</b>	Radio Link Control
<b>RLC</b>	Repair Logistic Centre
<b>RSL</b>	Radio Signalling Link
<b>R-state</b>	Release state
<b>RS232</b>	American standard for term/MODEM interconnection.
<b>rTMA</b>	Receiver TMA
	rTMA has no duplexers. It is used for amplification of the RX signal. ⇒ ddTMA ⇒ dTMA ⇒ TMA
<b>RTN</b>	Return
<b>RU</b>	Replaceable Unit
	An RU consists of one or more HWUs. An RU may be replaced by another RU of the same type. The RU is the smallest unit that can be handled on site.
<b>RX</b>	Receiver
<b>RX1</b>	Receiver antenna branch 1
<b>RX2</b>	Receiver antenna branch 2
<b>RXA</b>	Receiver antenna branch A
<b>RXB</b>	Receiver antenna branch B
<b>RXD</b>	Receiver Divider
<b>RXDA</b>	Receiver Divider Amplifier
<b>RXDP</b>	Receiver Distribution Plane
<b>RXLEV</b>	Measure of signal strength as defined in GSM:05.08:8.1.4
<b>RXQUAL</b>	Measure of signal quality as defined in GSM:05.08:8.2.4

<b>SACCH</b>	Slow Associated Control CHannel
<b>SCH</b>	Synchronization CHannel
<b>SDCCH</b>	Stand alone Dedicated Control CHannel
	Main dedicated signalling channel on the air interface, mainly used for call locating and establishment.
<b>SCU</b>	Switching and Combining Unit
<b>SE</b>	Supervised Entity
<b>SES</b>	Severely Errored Second
<b>SF</b>	Slip Frequency
<b>SID</b>	Silence Descriptor
<b>SIG</b>	Signalling
<b>SIM</b>	Subscriber Identity Module
<b>SIR</b>	Small Indoor RBS
<b>SMS</b>	Short Message Service (point to point)
	A short message, up to 160 alphanumeric characters long, can be sent to or from an MS (point to point).
<b>SO</b>	Service Object
<b>SS</b>	Swedish Standard
<b>Sub-RU</b>	A sub-replaceable unit is always connected to a superior Main RU. This connection is used for example for retrieval of the RU identity. A sub-RU normally does not have a processor. Note that an RU with a processor, which cannot be loaded, is classified as a sub-RU.
<b>SVS</b>	System Voltage Sensor
<b>SW</b>	SoftWare
<b>SWR</b>	Standing Wave Ratio
<b>SYNC</b>	Synchronous
<b>T1</b>	Transmission standard, G.703, a 1544 kbit/s PCM link

<b>TA</b>	Timing Advance  A signal sent by the BTS to the MS which the MS uses to advance its timing of transmissions to the BTS to compensate for propagation delay.
<b>TC</b>	Transaction Capabilities
<b>TCB</b>	Transceiver Control Board
<b>TCH</b>	Traffic CHannel  The traffic channels carry either encoded speech or user data.
<b>TCH/F</b>	Traffic Channel, Full-rate
<b>TCH/H</b>	Traffic Channel, Half-rate
<b>TCC</b>	Transmission Coherent Combining
<b>TCH SIG</b>	Traffic CHannel Signalling
<b>TD</b>	Transmit Data
<b>TDMA</b>	Time Division Multiple Access  Multiplexing of several channels in a common frequency band. Each channel is assigned a certain time division, a time slot.
<b>TDMA frame</b>	GSM air interface time frame comprising eight time slots.
<b>TEI</b>	Terminal Endpoint Identifier  TEI is an identification code carried by a LAPD frame as a terminal connection endpoint within a Service Access Point (SAP).
<b>TEMS</b>	TEst Mobile Station
<b>TF</b>	Timing Function
<b>TG</b>	Transceiver Group
<b>Timing bus</b>	The timing bus carries air timing information from the timing unit in the DXU to the TRUs.
<b>TLS</b>	Terrestrial Link Supervision

<b>TM</b>	Transport Module
	The Transport module is non-RBS equipment belonging to the transport network.
<b>TMA</b>	Tower Mounted Amplifier
	There are three types of TMAs: dTMA, rTMA and ddTMA. ⇒ dTMA ⇒ rTMA ⇒ ddTMA
<b>TMA-CM</b>	Tower Mounted Amplifier – Control Module
<b>TN</b>	Time slot Number
<b>TN O&amp;M</b>	Transport Network Operation and Maintenance (in general)
<b>Tora</b>	ASIC in the TRU
<b>TRA</b>	Transcoder Rate Adapter
	The TRA Unit (TRAU) in BSC performs transcoding of speech information and rate adaptation of data information.
<b>Tracy</b>	ASIC in the TRU
<b>TRS</b>	Transceiver System
<b>TRU</b>	Transceiver Unit
<b>TRX</b>	Transceiver (combined transmitter and receiver)
<b>TRXC</b>	Transceiver Controller
<b>TS</b>	Time Slot
	A 0.577 ms period (TDMA frame subunit) corresponding to 156.25 raw bits of information. The eight time slots of each TDMA frame are numbered 0...7.
	⇒ Burst
<b>TT</b>	Total Time
<b>TU</b>	Timing Unit
<b>TX</b>	Transmitter
<b>TXA</b>	Transmitter Antenna A

<b>TXB</b>	Transmitter Antenna B
<b>TXBP</b>	Transmitter BandPass filter
<b>TXU</b>	Radio Transmitter Unit
<b>UAS</b>	Unavailable Seconds
<b>UAST</b>	UnAvailable STate supervision
<b>UL</b>	Underwriter Laboratories
<b>uplink</b>	Signalling direction from the MS to the system.
<b>UPS</b>	Uninterrupted Power Supply
<b>VCO</b>	Voltage Controlled Oscillator
<b>VSWR</b>	Voltage Standing Wave Ratio RF signal measure. The quotient between transmitted and reflected voltage.
<b>X bus</b>	The X bus carries transmit air data frames between transceivers.
<b>Y link</b>	The interface between the DXU and each DSP System in core based TRUs.