

RBS Product Description

RBS 2106

DESCRIPTION

PRELIMINARY

Copyright

© Ericsson AB 2006, 2010. All rights reserved. No part of this document may be reproduced in any form without the written permission of the copyright owner.

Disclaimer

The contents of this document are subject to revision without notice due to continued progress in methodology, design and manufacturing. Ericsson shall have no liability for any error or damage of any kind resulting from the use of this document.

Trademark List

All trademarks mentioned herein are the property of their respective owners. These are shown in the document Trademark Information.

PRELIMINARY

Contents

| | | |
|-----------|---|-----------|
| 1 | Introduction | 1 |
| 1.1 | Revision Information | 1 |
| 2 | Product Overview | 2 |
| 2.1 | Main Features | 2 |
| 2.2 | Variants | 3 |
| 2.3 | Optional Equipment | 3 |
| 2.4 | WCDMA Equipment | 5 |
| 3 | Dimensions | 6 |
| 4 | Space Requirements | 9 |
| 5 | Environment | 11 |
| 5.1 | Operating Environment | 11 |
| 5.2 | Environmental Impact | 12 |
| 5.3 | Compliance Distances for Electromagnetic Exposure | 20 |
| 5.4 | Materials | 22 |
| 6 | Hardware Units | 23 |
| 6.1 | Standard Hardware Units | 25 |
| 6.2 | Optional Hardware Units | 28 |
| 7 | Interfaces | 32 |
| 7.1 | External Connections | 32 |
| 7.2 | Test Interface | 38 |
| 7.3 | Operator Interface | 38 |
| 8 | Power System | 40 |
| 8.1 | Power Supply | 41 |
| 8.2 | Battery Backup | 42 |
| 8.3 | Output Power to TM | 42 |
| 8.4 | Power Consumption | 42 |
| 9 | Transmission | 44 |
| 10 | External Alarms | 45 |

| | | |
|-----------|---|-----------|
| 11 | Standards, Regulations and Dependability | 46 |
| 11.1 | Safety Standards | 46 |
| 11.2 | Other Standards and Regulations | 46 |

PRELIMINARY

1 Introduction

RBS 2106 is a member of the RBS 2000 family. It is a 12-Transceiver (TRX) radio base station for outdoor applications. The RBS 2106 can be configured for omniceils or for multisector cells of up to three sectors.

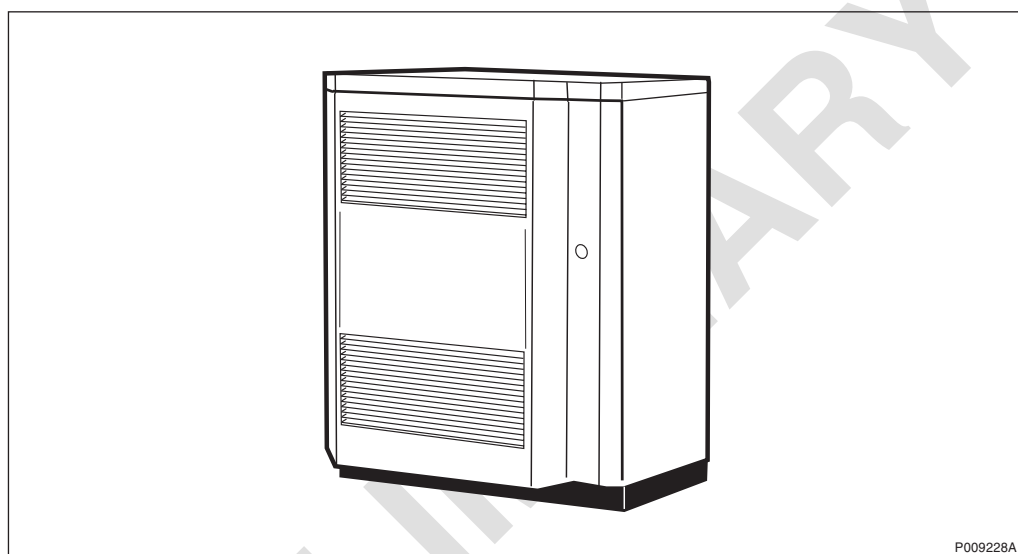

Figure 1 RBS 2106

1.1 Revision Information

Other than editorial changes, this document has been revised as follows:

- Section Dimension: Weights for RBS 2106 V3 have been corrected
- Section Hardware Units: Information about the climate units has been updated
- Section Hardware Units: Information about the CDU-types has been updated
- Section Hardware Units: Information about the DC filter has been updated
- Section Power System: BFU-32 has been added
- Section Power Consumption: Power consumption values for RBS 2106 V3 have been corrected
- Minor clarifications of technical matters throughout the document

2 Product Overview

RBS 2106 is a high-capacity outdoor base station equipped with up to six Double Transceiver Units (dTRU), with space inside for both transmission equipment and battery backup.

RBS 2106 is designed to be transported as a fully assembled cabinet, without batteries, to the site. All units in the cabinet is easily accessible from the front, which means it can be installed with the back against a wall.

Note: The RBS 2106 is available in three variants:

- RBS 2106
- RBS 2106i
- RBS 2106 V3

Unless otherwise stated, the term RBS 2106 is used when common features of the three variants are described. The variant names are used only when specific features for the variants are described in this document.

Note: The figures are representational only and may not be entirely accurate in every case.

2.1 Main Features

The RBS 2106 supports the following features:

- 12 TRXs
- Co-siting (antenna sharing) with GSM, TDMA, WCDMA systems
- Discontinuous transmission/reception
- Duplex filters
- Dynamic power regulation
- Encryption/ciphering
- Enhanced Data Rate for Global Evolution (EDGE)
- Expansion by Transceiver Group (TG) synchronization
- External alarms
- Frequency hopping

- Internal battery backup
- RBS synchronization through the Global Positioning System (GPS)
- Power supply system: can be connected to 200 – 250 V AC mains supplies
- Radio configurations supported on 800, 900, 1800, and 1900 MHz
- Receiver diversity
- Transmission Interface: the following transport network interface alternatives exist:
 - T1 1,544 kbps, 100 Ω , with PCM synchronization
 - E1 2,048 kbps, 75 Ω , with PCM synchronization
 - E1 2,048 kbps, 120 Ω , with PCM synchronization

2.2 Variants

The RBS 2106 is available in three variants:

- RBS 2106
- RBS 2106i
- RBS 2106 V3

The RBS can be equipped with variants of the following items, as selected when ordering:

- Heat exchanger climate unit or combined climate unit
- Two standard colours
- AC service outlet according to local standards, or not

2.3 Optional Equipment

The equipment listed below is available but not necessary for basic operation:

- Auxiliary Distribution Module (ADM)
- Antenna-Sharing Unit (ASU)
- Base frame
- Battery backup
- Control Module for Tower-Mounted Amplifiers (TMA-CM)

- Bias injectors for DC power supply of TMAs
- DC/DC converter
- DC filter
- Dual-Duplex Tower-Mounted Amplifier (ddTMA)
- External Synchronization Bus (ESB)
- External alarms
- GPS synchronization solution (external GPS antenna)
- Hybrid Combiner Unit (HCU)
- Operator-specific keys
- Mini-Link
- Overvoltage Protection (OVP)
- Redundant Power Supply Unit (PSU)
- Smoke detector
- Sound hood

PRELIMINARY

2.4 WCDMA Equipment

In some configurations the RBS can host equipment for a WCDMA RBS, which is then powered from the GSM RBS.

The figure below shows an RBS with WCDMA equipment.

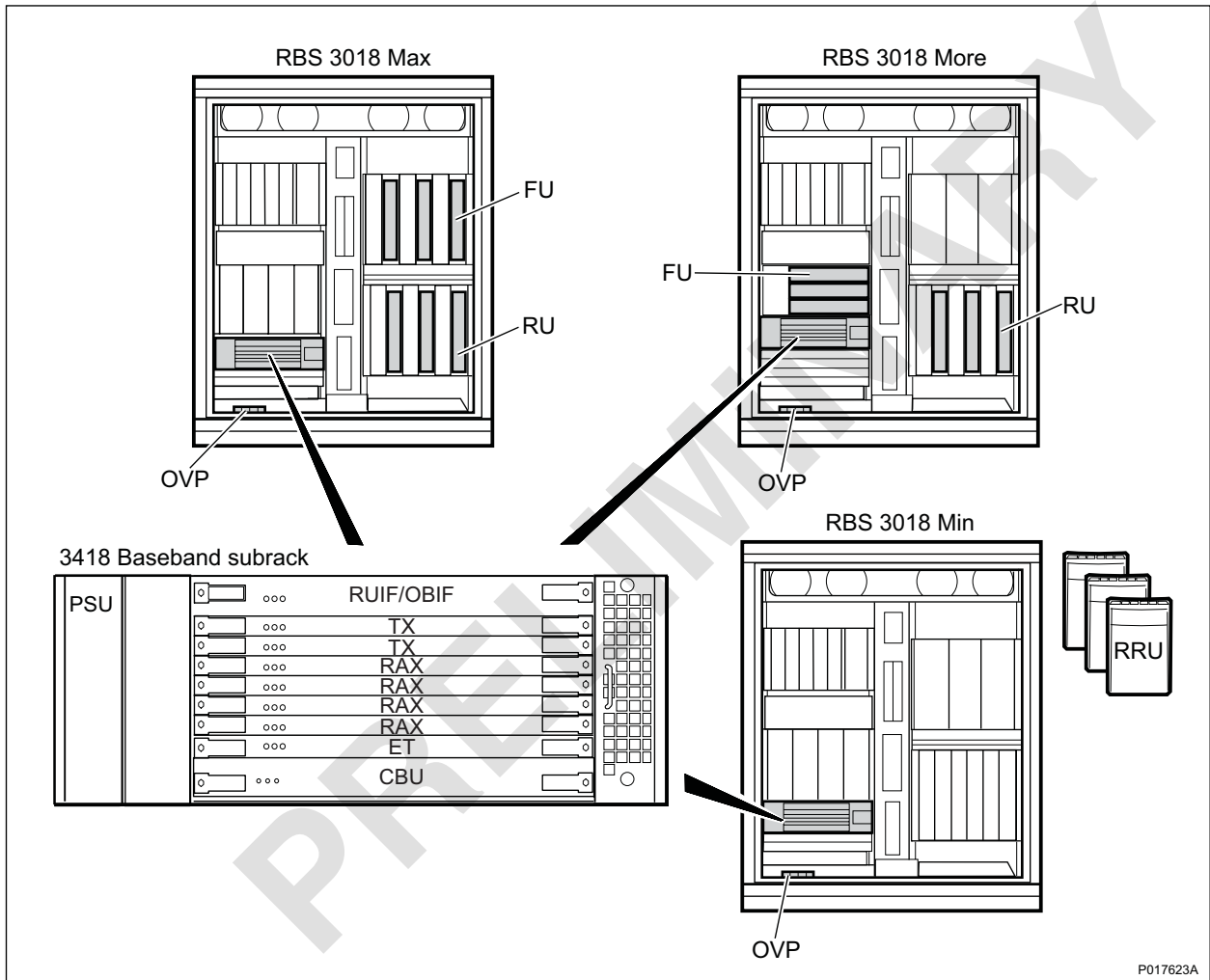

Figure 2 GSM RBS with WCDMA Equipment

3 Dimensions

This section describes the dimensions and colours of the RBS 2106.

Size and Weight

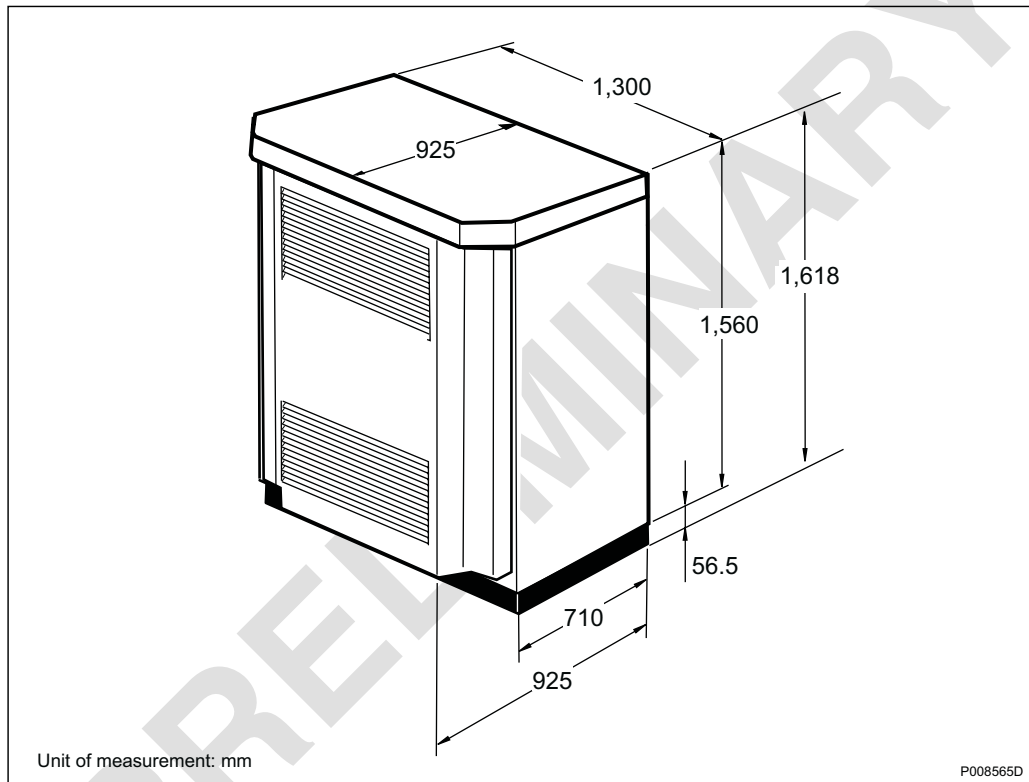

Figure 3 RBS with Combined Climate Unit

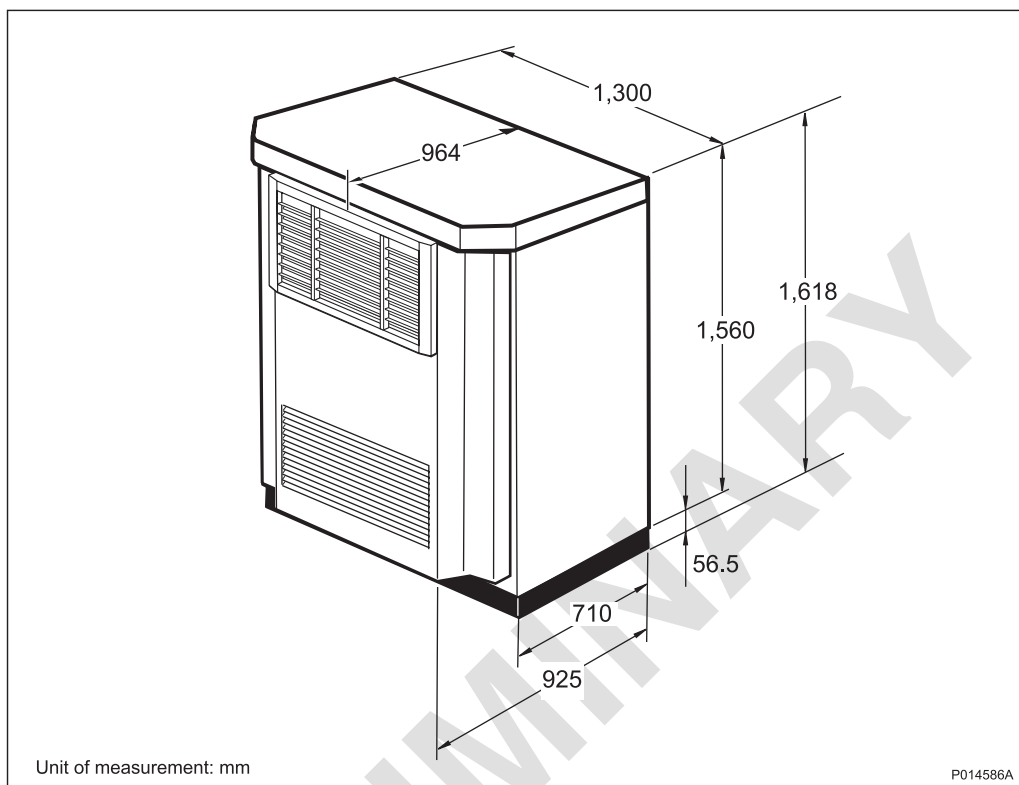

Figure 4 RBS with Heat Exchanger Climate Unit

Table 1 RBS Weights with Combined Climate Unit

| Configuration | RBS 2106 | RBS 2106i | RBS 2106 V3 |
|------------------------------------|----------|-----------|-------------|
| Fully equipped including batteries | 660 kg | 700 kg | 806 kg |
| Fully equipped excluding batteries | 520 kg | 560 kg | 602 kg |
| Door | 150 kg | 150 kg | 150 kg |

Table 2 RBS Weights with Heat Exchanger Climate Unit

| Configuration | RBS 2106 | RBS 2106i | RBS 2106 V3 |
|------------------------------------|----------|-----------|-------------|
| Fully equipped including batteries | 640 kg | 650 kg | 771 kg |
| Fully equipped excluding batteries | 500 kg | 510 kg | 568 kg |
| Door | 140 kg | 120 kg | 116 kg |

Surface and Colour

The RBS 2106 has a surface quality according to Ericsson standard class A3/B6.

Table 3 RBS 2106 Colours

| Colour | Reference Number |
|---------------|-------------------------|
| Grey | RAL 7035 |
| Green | NCS 8010-G 10Y |

PRELIMINARY

4 Space Requirements

Installation and maintenance require that the door can be opened at least 90°. In practice, this means that the space in front of the cabinet must be kept clear for a distance of 1,300 mm, as shown in the figure below. The space above the cabinet must be at least 100 mm. No space is required behind the cabinet.

If the RBS is located next to another cabinet of the same depth, no adjacent space is required. If the RBS is placed next to a wall, or any object protrudes on the left side, then 175 mm clearance is required to the left of the cabinet.

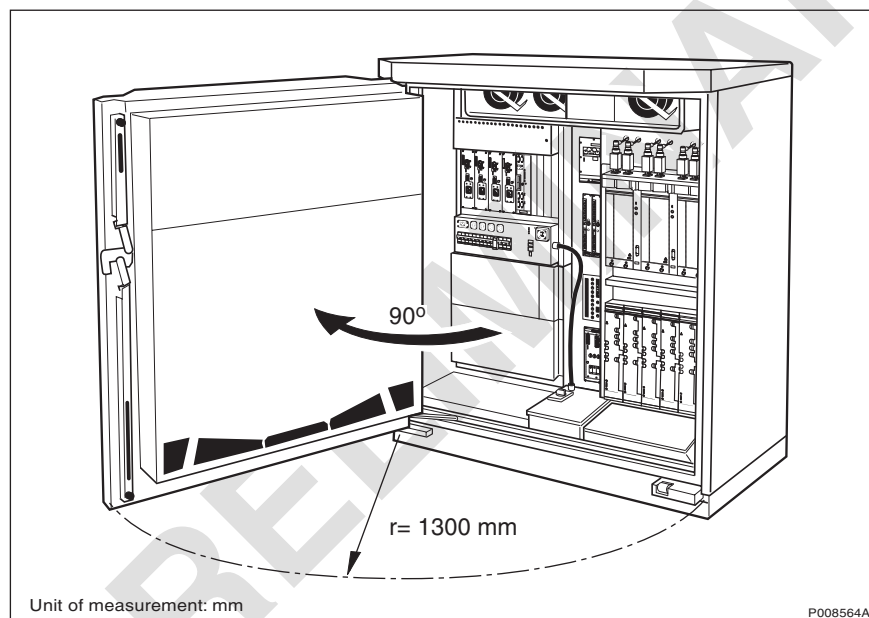

Figure 5 Door-Opening Requirements

Note: All installation and maintenance work can be performed with the door open 90°.

During service, a tent can be placed over the cabinet to protect the equipment from unsuitable weather conditions.

Footprint

The footprint of the RBS 2106 is 1,300 mm wide and 710 mm deep. Observe that the door is not included in the footprint, as it does not extend to the ground. The installation frame of the RBS 2106 has the same bottom holing pattern as that of the RBS 2102.

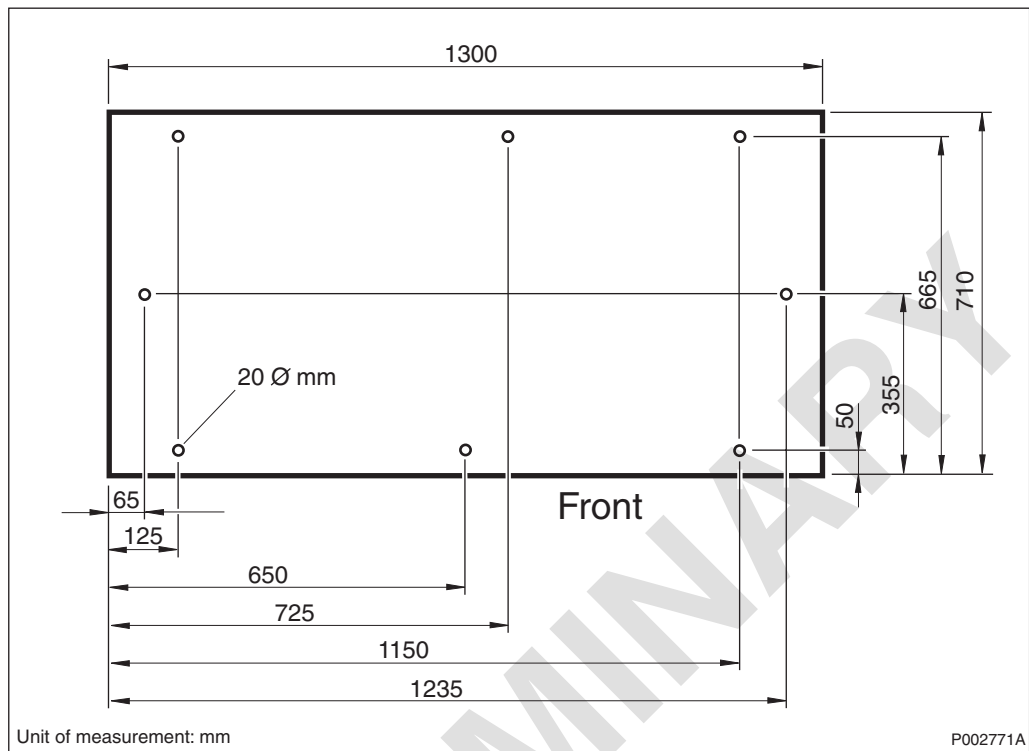

Figure 6 Base Frame and Installation Frame Holing Pattern

5 Environment

The RBS 2106 is designed to operate within the limits stated for climatic requirements listed in the table below, and to withstand ground vibrations as stated below.

5.1 Operating Environment

Climatic Requirements

The operating environment and climatic specifications are shown in the tables below.

Table 4 RBS 2106 Climatic Requirements

| Description | Temperature | Relative Humidity |
|-------------------|-------------------------------|-------------------|
| Normal Conditions | –33°C to +45°C ⁽¹⁾ | 15 – 100% |
| | –33°C to +40°C ⁽²⁾ | |
| Transport | –40°C to +70°C | 5 – 100% |
| Storage | –25°C to +55°C | 10 – 100% |
| Handling | –40°C to +70°C | 5 – 100% |

(1) Temperature range valid if combined climate unit is used.

(2) Temperature range valid if heat exchanger climate unit is used.

Table 5 RBS 2106i and RBS 2106 V3 Climatic Requirements

| Description | Temperature | Relative Humidity |
|-------------------|----------------|-------------------|
| Normal Conditions | –33°C to +45°C | 15 – 100% |
| Transport | –40°C to +70°C | 5 – 100% |
| Storage | –25°C to +55°C | 10 – 100% |
| Handling | –40°C to +70°C | 5 – 100% |

Ground Vibrations

The RBS 2106 is designed to satisfy earthquake protection according to IEC 68-2-57.

Levelling

To ensure that the cabinet is level, the floor must be level to within ± 3 mm/2000 mm and the floor gradient must be within $\pm 0.1^\circ$.

5.2 Environmental Impact

This section describes the effects that the cabinet has on the environment.

5.2.1 Heat Dissipation

The RBS 2106 (RBS 2106, RBS 2106i or RBS 2106 V3) generates an average heat load of 3000 W. The exact figure is dependent upon configuration, equipment, and site-specific conditions.

5.2.2 Acoustic Dispersion with Combined Climate Unit

The cabinet noise dispersion for an RBS 2106 (RBS 2106, RBS 2106i or RBS 2106 V3) with Combined Climate Unit is shown in the tables below. The figures and tables show the noise dispersion generated by a free-standing cabinet and by a cabinet mounted against a wall.

Note: The acoustic noise dispersion values for a free-standing cabinet and a cabinet installed against a wall were tested according to the ISO 9614-2 standard. Deviations from these values can be experienced due to the nature of materials in the environment where the cabinet is installed. Objects near the cabinet can reflect or absorb sound and thus affect acoustic dispersion.

The following two tables show the sound pressure levels, calculated at the bystander position at a distance of 1 metre from the cabinet and 1.5 metre above the floor. The calculations are valid in free field. If the RBS is placed in a room the sound pressure level will be higher than indicated in the tables below.

Table 6 Sound Pressure Level, Bystander Position without Sound Hood

| Operating Condition | Sound Pressure Level at the Bystander Position at a Distance of one Metre, $L_{pA}Db$ | | | |
|---------------------|---|------|-------|------|
| | Front | Left | Right | Back |
| 20°C | 58 | 54 | 55 | 50 |
| 25°C | 60 | 56 | 57 | 51 |
| 30°C | 57 | 53 | 54 | 49 |
| 45°C | 62 | 58 | 59 | 53 |

Table 7 Sound Pressure Level, Bystander Position with Sound Hood

| Operating Condition | Sound Pressure Level at the Bystander Position at a Distance of one Metre, $L_{pA}Db$ | | | |
|---------------------|---|------|-------|------|
| | Front | Left | Right | Back |
| 20°C | 51 | 50 | 51 | 49 |

| Operating Condition | Sound Pressure Level at the Bystander Position at a Distance of one Metre, $L_{pA}Db$ | | | |
|---------------------|---|------|-------|------|
| | Front | Left | Right | Back |
| 25°C | 50 | 49 | 50 | 48 |
| 30°C | 48 | 48 | 48 | 47 |
| 45°C | 54 | 52 | 53 | 51 |

The following figures and tables show the noise dispersion for different ambient temperature and at different distances from the cabinet.

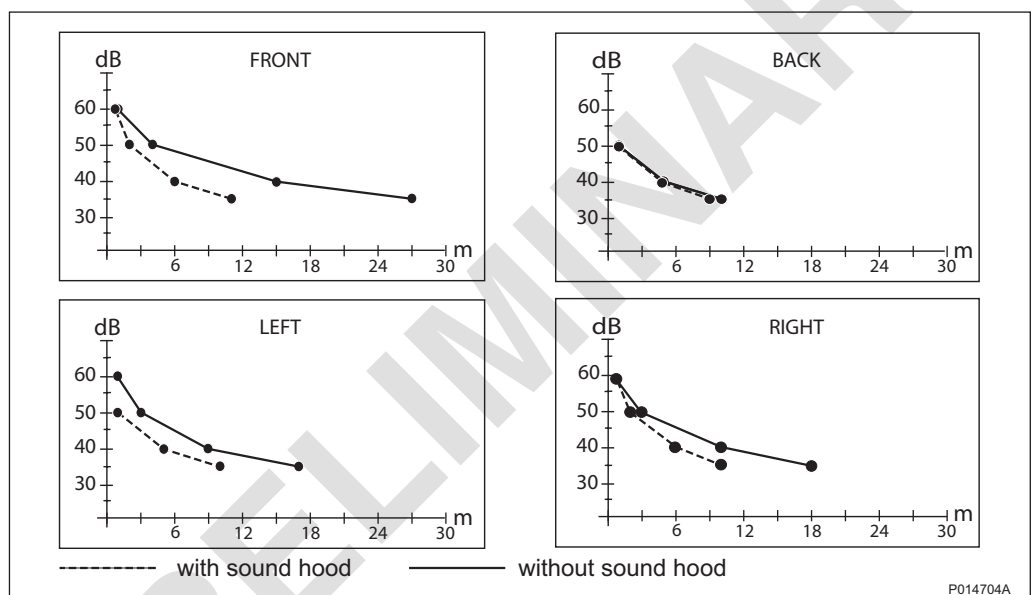

Figure 7 Sound Pressure Levels at 20°C, Free-Standing RBS with Combined Climate Unit, with and without Sound Hood

Table 8 Sound Pressure Levels for a Free Standing RBS with Combined Climate Unit

| Temp | Sound Pressure Level, dBA | Calculated Distance in Metres, Each Direction | | | | | | | |
|------|---------------------------|---|------|-------|------|-----------------|------|-------|------|
| | | Without Sound Hood | | | | With Sound Hood | | | |
| | | Front | Left | Right | Back | Front | Left | Right | Back |
| 20° | 35 | 27 | 17 | 18 | 10 | 11 | 10 | 11 | 9 |
| | 40 | 15 | 9 | 10 | 5 | 6 | 5 | 6 | 5 |
| | 50 | 4 | 3 | 3 | 1 | 2 | 1 | 2 | 1 |
| | 60 | <1 | <1 | <1 | <1 | <1 | <1 | <1 | <1 |

Table 8 Sound Pressure Levels for a Free Standing RBS with Combined Climate Unit

| Temp. | Sound Pressure Level, dBA | Calculated Distance in Metres, Each Direction | | | | | | | |
|-------|---------------------------|---|------|-------|------|-----------------|------|-------|------|
| | | Without Sound Hood | | | | With Sound Hood | | | |
| | | Front | Left | Right | Back | Front | Left | Right | Back |
| 25° | 35 | 34 | 21 | 22 | 11 | 10 | 9 | 10 | 8 |
| | 40 | 19 | 12 | 12 | 6 | 5 | 5 | 5 | 4 |
| | 50 | 6 | 3 | 3 | 2 | 1 | 1 | 1 | <1 |
| | 60 | 1 | <1 | <1 | <1 | <1 | <1 | <1 | <1 |
| 30° | 35 | 24 | 15 | 16 | 9 | 8 | 7 | 8 | 7 |
| | 40 | 13 | 8 | 9 | 5 | 4 | 4 | 4 | 4 |
| | 50 | 4 | 2 | 2 | <1 | <1 | <1 | <1 | <1 |
| | 60 | <1 | <1 | <1 | <1 | <1 | <1 | <1 | <1 |
| 45° | 35 | 43 | 26 | 28 | 13 | 15 | 13 | 14 | 12 |
| | 40 | 24 | 15 | 15 | 7 | 8 | 7 | 8 | 6 |
| | 50 | 7 | 4 | 4 | 2 | 2 | 2 | 2 | 2 |
| | 60 | 2 | <1 | <1 | <1 | <1 | <1 | <1 | <1 |

Table 9 Sound Pressure Levels for an RBS against a Wall, with Combined Climate Unit

| Temp. | Sound Pressure Level, dBA | Calculated Distance in Metres, Each Direction | | | | | |
|-------|---------------------------|---|------|-------|-----------------|------|-------|
| | | Without Sound Hood | | | With Sound Hood | | |
| | | Front | Left | Right | Front | Left | Right |
| 20° | 35 | 28 | 20 | 21 | 13 | 14 | 15 |
| | 40 | 15 | 11 | 12 | 7 | 7 | 8 |
| | 50 | 4 | 3 | 3 | 2 | 2 | 2 |
| | 60 | <1 | <1 | <1 | <1 | <1 | <1 |
| 25° | 35 | 35 | 25 | 26 | 12 | 12 | 13 |
| | 40 | 19 | 13 | 14 | 6 | 7 | 7 |
| | 50 | 6 | 4 | 4 | 1 | 2 | 2 |
| | 60 | 1 | <1 | <1 | <1 | <1 | <1 |
| 30° | 35 | 25 | 14 | 16 | 9 | 10 | 11 |
| | 40 | 14 | 8 | 9 | 5 | 5 | 8 |
| | 50 | 4 | 2 | 2 | 1 | 1 | 1 |
| | 60 | <1 | <1 | <1 | <1 | <1 | <1 |

Table 9 Sound Pressure Levels for an RBS against a Wall, with Combined Climate Unit

| Temp. | Sound Pressure Level, dBA | Calculated Distance in Metres, Each Direction | | | | | |
|-------|---------------------------|---|------|-------|-----------------|------|-------|
| | | Without Sound Hood | | | With Sound Hood | | |
| | | Front | Left | Right | Front | Left | Right |
| 45° | 35 | 44 | 30 | 32 | 18 | 17 | 18 |
| | 40 | 25 | 16 | 18 | 10 | 9 | 10 |
| | 50 | 7 | 5 | 5 | 3 | 2 | 3 |
| | 60 | 2 | <1 | <1 | <1 | <1 | <1 |

5.2.3 Acoustic Dispersion with Heat Exchanger (RBS 2106)

The cabinet noise dispersion for an RBS 2106 with Heat Exchanger Climate Unit is shown in the tables below. The figures and tables show the noise dispersion generated by a free-standing cabinet and by a cabinet mounted against a wall.

Note: The acoustic noise dispersion values for a free-standing cabinet and a cabinet installed against a wall were tested according to the ISO 9614-2 standard. Deviations from these values can be experienced due to the nature of materials in the environment where the cabinet is installed. Objects near the cabinet can reflect or absorb sound and thus affect acoustic dispersion.

The following two tables show the sound pressure levels, calculated at the bystander position at a distance of 1 metre from the cabinet and 1.5 metre above the floor. The calculations are valid in free field. If the RBS is placed in a room the sound pressure level will be higher than indicated in the tables below.

Table 10 Sound Pressure Level, Bystander Position without Sound Hood

| Operating Condition | Sound Pressure Level at the Bystander Position at a Distance of one metre, L_{pA} dB | | | |
|---------------------|--|------|-------|------|
| | Front | Left | Right | Back |
| 15°C | 49 | 47 | 47 | 45 |
| 20°C | 55 | 52 | 52 | 48 |
| 25°C | 59 | 56 | 56 | 52 |
| 30°C | 62 | 59 | 59 | 53 |

Table 11 Sound Pressure Level, Bystander Position with Sound Hood

| Operating Condition | Sound Pressure Level at the Bystander Position at a Distance of one Metre, L_{pA} dB | | | |
|---------------------|--|------|-------|------|
| | Front | Left | Right | Back |
| 15°C | 45 | 45 | 44 | 45 |

| Operating Condition | Sound Pressure Level at the Bystander Position at a Distance of one Metre, L _{pA} dB | | | |
|---------------------|---|------|-------|------|
| | Front | Left | Right | Back |
| 20°C | 48 | 48 | 48 | 47 |
| 25°C | 51 | 50 | 50 | 50 |
| 30°C | 53 | 52 | 52 | 51 |

The following figures and tables show the noise dispersion for different ambient temperature and at different distances from the cabinet.

Table 12 Sound Pressure Levels for a Free Standing RBS 2106 with Heat Exchanger

| Temp. | Sound Pressure Level dBA | Calculated Distance in Metres, Each Direction | | | | | | | |
|-------|--------------------------|---|------|-------|------|-----------------|------|-------|------|
| | | Without Sound Hood | | | | With Sound Hood | | | |
| | | Front | Left | Right | Back | Front | Left | Right | Back |
| 15° | 35 | 10 | 7 | 7 | 5 | 5 | 5 | 5 | 5 |
| | 40 | 5 | 4 | 4 | 3 | 3 | 3 | 3 | 3 |
| | 50 | <1 | <1 | <1 | <1 | <1 | <1 | <1 | <1 |
| | 60 | <1 | <1 | <1 | <1 | <1 | <1 | <1 | <1 |
| 20° | 35 | 19 | 13 | 13 | 8 | 8 | 7 | 7 | 7 |
| | 40 | 11 | 7 | 7 | 4 | 4 | 4 | 4 | 4 |
| | 50 | 2 | 2 | 2 | <1 | <1 | <1 | <1 | <1 |
| | 60 | <1 | <1 | <1 | <1 | <1 | <1 | <1 | <1 |
| 25° | 35 | 31 | 21 | 21 | 12 | 13 | 12 | 12 | 11 |
| | 40 | 17 | 11 | 11 | 7 | 7 | 6 | 6 | 6 |
| | 50 | 5 | 3 | 3 | 2 | 2 | 1 | 1 | 1 |
| | 60 | <1 | <1 | <1 | <1 | <1 | <1 | <1 | <1 |
| 30° | 35 | 43 | 28 | 28 | 14 | 16 | 15 | 15 | 13 |
| | 40 | 24 | 15 | 15 | 8 | 8 | 8 | 8 | 6 |
| | 50 | 7 | 4 | 4 | 2 | 2 | 2 | 2 | 2 |
| | 60 | 2 | <1 | <1 | <1 | <1 | <1 | <1 | <1 |

Table 13 Sound Pressure Levels for an RBS 2106 Against a Wall, with Heat Exchanger

| Temp | Sound Pressure Level dBA | Calculated Distance in Metres, Each Direction | | | | | |
|------|--------------------------|---|------|-------|-----------------|------|-------|
| | | Without Sound Hood | | | With Sound Hood | | |
| | | Front | Left | Right | Front | Left | Right |
| 15° | 35 | 10 | 8 | 8 | 5 | 6 | 6 |
| | 40 | 5 | 4 | 4 | 3 | 3 | 3 |
| | 50 | 1 | <1 | <1 | <1 | <1 | <1 |
| | 60 | <1 | <1 | <1 | <1 | <1 | <1 |
| 20° | 35 | 20 | 16 | 16 | 10 | 10 | 10 |
| | 40 | 11 | 8 | 8 | 5 | 5 | 5 |
| | 50 | 3 | 2 | 2 | <1 | <1 | <1 |
| | 60 | <1 | <1 | <1 | <1 | <1 | <1 |
| 25° | 35 | 33 | 25 | 25 | 15 | 14 | 14 |
| | 40 | 18 | 14 | 14 | 8 | 8 | 8 |
| | 50 | 6 | 4 | 4 | 2 | 2 | 2 |
| | 60 | 2 | <1 | <1 | <1 | <1 | <1 |
| 30° | 35 | 45 | 32 | 32 | 16 | 17 | 17 |
| | 40 | 25 | 18 | 18 | 9 | 9 | 9 |
| | 50 | 7 | 5 | 5 | 2 | 2 | 2 |
| | 60 | 2 | 1 | <1 | <1 | <1 | <1 |

5.2.4 Acoustic Dispersion with Heat Exchanger (RBS 2106i or RBS 2106 V3)

The cabinet noise dispersion for an RBS 2106i or RBS 2106 V3 with Heat Exchanger Climate Unit is shown in the figures and tables below. The figures and tables show the noise dispersion generated by a free-standing cabinet and by a cabinet mounted against a wall.

Note: The acoustic noise dispersion values for a free-standing cabinet and a cabinet installed against a wall were tested according to the ISO 9614-2 standard. Deviations from these values can be experienced due to the nature of materials in the environment where the cabinet is installed. Objects near the cabinet can reflect or absorb sound and thus affect acoustic dispersion.

The following two tables show the sound pressure levels, calculated at the bystander position at a distance of 1 metre from the cabinet and 1.5 metre above the floor. The calculations are valid in free field. If the RBS is placed in a room the sound pressure level will be higher than indicated in the tables below.

Table 14 Sound Pressure Level, Bystander Position without Sound Hood

| Operating Condition | Sound Pressure Level at the Bystander Position at a Distance of One metre, L _{pA} dB | | | |
|---------------------|---|------|-------|------|
| | Front | Left | Right | Back |
| 15°C | 45 | 42 | 41 | 38 |
| 20°C | 45 | 42 | 42 | 38 |
| 25°C | 46 | 43 | 44 | 43 |
| 30°C | 55 | 51 | 51 | 46 |
| 45°C | 60 | 57 | 57 | 52 |

The following figures and tables show the noise dispersion for different ambient temperature and at different distances from the cabinet.

Table 15 Sound Pressure Levels for a Free Standing RBS 2106i or RBS 2106 V3 with Heat Exchanger

| Temp. | Sound Pressure Level, dBA | Calculated Distance in Metres, Each Direction | | | |
|-------|---------------------------|---|------|-------|------|
| | | Front | Left | Right | Back |
| 15° | 35 | 5 | 4 | 3 | 2 |
| | 40 | 3 | 2 | 2 | <1 |
| | 50 | <1 | <1 | <1 | <1 |
| | 60 | <1 | <1 | <1 | <1 |
| 20° | 35 | 6 | 4 | 4 | 2 |
| | 40 | 3 | 2 | 2 | <1 |
| | 50 | <1 | <1 | <1 | <1 |
| | 60 | <1 | <1 | <1 | <1 |
| 25° | 35 | 6 | 4 | 4 | 4 |
| | 40 | 3 | 2 | 2 | 2 |
| | 50 | <1 | <1 | <1 | <1 |
| | 60 | <1 | <1 | <1 | <1 |
| 30° | 35 | 18 | 11 | 11 | 6 |
| | 40 | 10 | 6 | 6 | 3 |
| | 50 | 3 | 2 | 2 | <1 |
| | 60 | <1 | <1 | <1 | <1 |

| Temp. | Sound Pressure Level, dBA | Calculated Distance in Metres, Each Direction | | | |
|-------|---------------------------|---|------|-------|------|
| | | Front | Left | Right | Back |
| 45° | 35 | 35 | 22 | 22 | 12 |
| | 40 | 19 | 12 | 12 | 7 |
| | 50 | 6 | 4 | 4 | 2 |
| | 60 | 1 | <1 | <1 | <1 |

Table 16 Sound Pressure Levels for an RBS 2106i or RBS 2106 V3 with Heat Exchanger, against a Wall

| Temp (C°) | Sound Pressure Level, dB(A) | Calculated Distance in Metres, Each Direction | | |
|--------------|-----------------------------|---|------|-------|
| | | Front | Left | Right |
| 15° | 35 | 6 | 4 | 4 |
| | 40 | 3 | 2 | 2 |
| | 50 | <1 | <1 | <1 |
| | 60 | <1 | <1 | <1 |
| 20° | 35 | 6 | 4 | 4 |
| | 40 | 3 | 2 | 2 |
| | 50 | <1 | <1 | <1 |
| | 60 | <1 | <1 | <1 |
| 25° | 35 | 6 | 6 | 7 |
| | 40 | 3 | 3 | 3 |
| | 50 | <1 | <1 | <1 |
| | 60 | <1 | <1 | <1 |
| 30° | 35 | 18 | 13 | 13 |
| | 40 | 10 | 7 | 7 |
| | 50 | 3 | 2 | 2 |
| | 60 | <1 | <1 | <1 |
| 45° | 35 | 36 | 26 | 26 |
| | 40 | 20 | 14 | 14 |
| | 50 | 6 | 4 | 4 |
| | 60 | 2 | <1 | <1 |

5.3 Compliance Distances for Electromagnetic Exposure

The compliance distance is the minimum separation that must be kept between the antenna and a person to ensure that the ICNIRP Radio Frequency (RF) exposure limits are not exceeded.

Note: ICNIRP, “Guidelines for limiting exposure to time-varying electric, magnetic, and electromagnetic fields (up to 300 GHz)”, International Commission on Non-Ionizing Radiation Protection, Health Physics, vol. 74, no. 4, 1998.

Ericsson has performed a free-space near-field RF exposure assessment of typical configurations of the RBS 2106 with a recommended antenna. The resulting dimensions, in metres, for a compliance boundary for both public and occupational exposure, are shown in *Table 17*.

The compliance boundary is defined as a cylinder around the antenna, *see figure below*. The antenna is not located at the centre of the cylinder. Instead it is located almost at the edge, facing towards the center of the cylinder. The distance between the antenna's rear and the edge of the cylinder is the so-called distance behind antenna. The height of the cylinder is the antenna height plus equal distances above and below the antenna. The cylinder shape overestimates the compliance distances right beside the antenna.

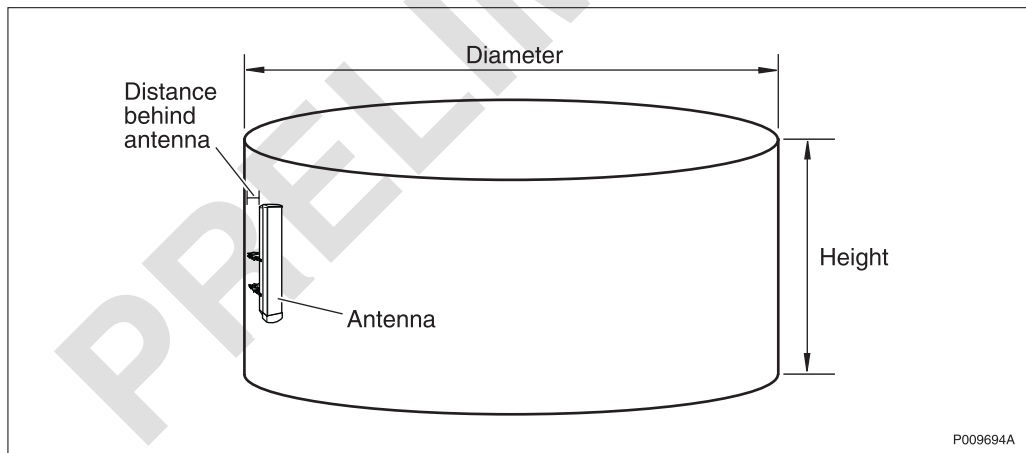

Figure 8 Compliance Boundary Cylinder

Table 17 Compliance Boundary Dimensions for the General Public (GP) and Occupational (O) Exposure for Typical Configurations

| Configuration | Frequency (MHz) | Dimensions of Cylindrical Compliance Boundary in (m) | | | | | |
|----------------------|-----------------|--|---|--------|-----|-------------------------|------|
| | | Diameter | | Height | | Distance Behind Antenna | |
| | | GP | O | GP | O | GP | O |
| 3x2 no hybrid | 900 | 6 | 3 | 1.7 | 1.5 | 0.1 | 0.1 |
| | 1800 | 5 | 1 | 1.6 | 1.4 | 0.1 | 0.05 |
| 3x4 combined | 900 | 6 | 3 | 1.6 | 1.5 | 0.1 | 0.1 |
| | 1800 | 5 | 1 | 1.6 | 1.4 | 0.1 | 0.05 |
| 3x2 TCC | 900 | 8 | 4 | 1.9 | 1.6 | 0.1 | 0.1 |
| | 1800 | 7 | 2 | 1.6 | 1.5 | 0.1 | 0.1 |
| 1x12 filter combiner | 900 | 11 | 5 | 2.3 | 1.6 | 0.1 | 0.1 |
| | 1800 | 9 | 4 | 1.8 | 1.6 | 0.1 | 0.1 |

The cylinder shape overestimates the compliance distances right beside the antenna. In reality the occupational compliance distance by the side, in line with the front of the antenna, is less than 0.1 metres for output power levels below 56 W and less than 0.3 metres for the other power levels reported here. For characteristics of an antenna recommended for typical configurations of RBS 2106, see table below.

Table 18 Characteristics of Typical Antenna

| Antenna Attribute | Specification |
|----------------------------------|---|
| Type | X-pol macro RBS sector antenna (KRE 101 1916/1) |
| Height | 1.3 m |
| Horizontal half-power beam width | 60 degrees |
| Vertical half-power beam width | 15 degrees at 900 MHz 7 degrees at 1800 MHz |
| Gain | 14.5 dBi at 900 MHz 17 dBi at 1800 MHz |
| Downtilt | 0 degrees |

The nominal maximum power fed to the antenna, as a function of the number of transceiver units (TRUs) per antenna and the maximum power (including

tolerances and transmission loss) per TRU, for RBS 2106 at 900 MHz and 1800 MHz, are given in *Table 19*.

Table 19 Maximum Power to Antenna for Various RBS 2106 Configurations

| Configuration | Frequency (MHz) | Nominal Output Power per TRU (dBm)/(W) | Maximum Power to Antenna ⁽¹⁾ (dBm)/(W) |
|----------------------|------------------------|---|--|
| 3x2 no hybrid | 900 | 45.2 / 33 | 47.2 / 52 |
| | 1800 | 44 / 25 | 46 / 40 |
| 3x4 combined | 900 | 41.7 / 15 | 46.7 / 47 |
| | 1800 | 40.5 / 11 | 45.5 / 35 |
| 3x2 TCC | 900 | 47.7 / 59 | 49.7 / 93 |
| | 1800 | 46.5 / 45 | 48.5 / 71 |
| 1x12 filter combiner | 900 | 42.7 / 19 | 52.5 / 177 |
| | 1800 | 41.5 / 14 | 51.3 / 135 |

(1) Including power tolerance level (+2 dB) and transmission losses (−3 dB).

5.4

Materials

All Ericsson products fulfil legal, market, and Ericsson requirements regarding the following:

- Fire resistance of materials, components, wires, and cables
- Declaration of materials
- Use of restricted materials
- Recycling

Packaging

The packaging is recyclable.

6 Hardware Units

A high level of availability is achieved using strict functional modularity in a system of standardized Replaceable Units (RU). A failed RU can easily be replaced by a new one.

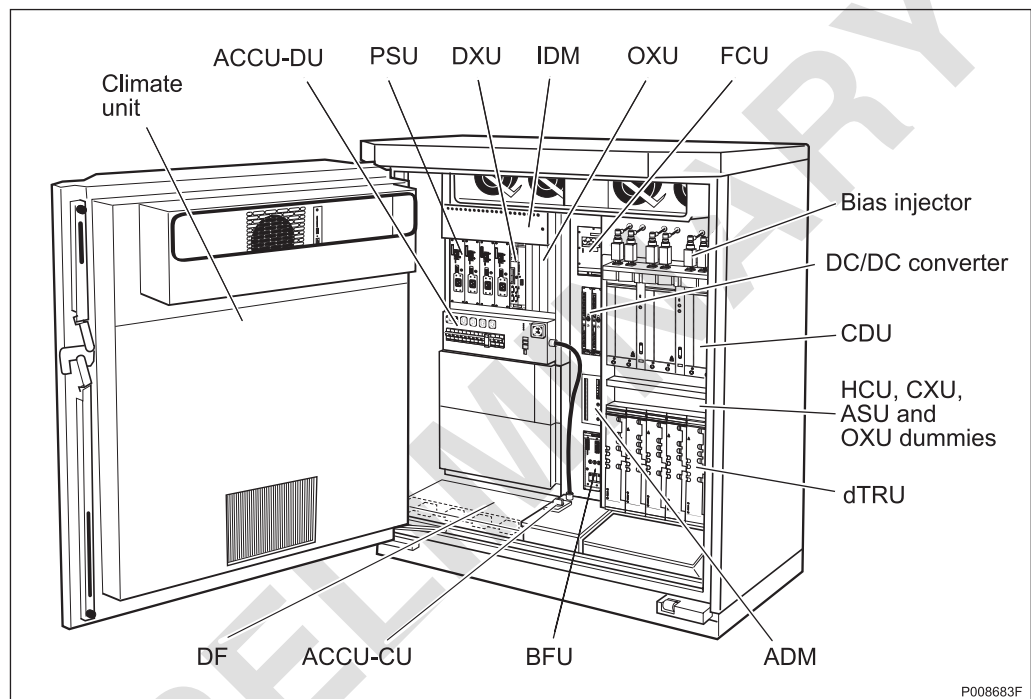

Figure 9 RBS 2106 Overview

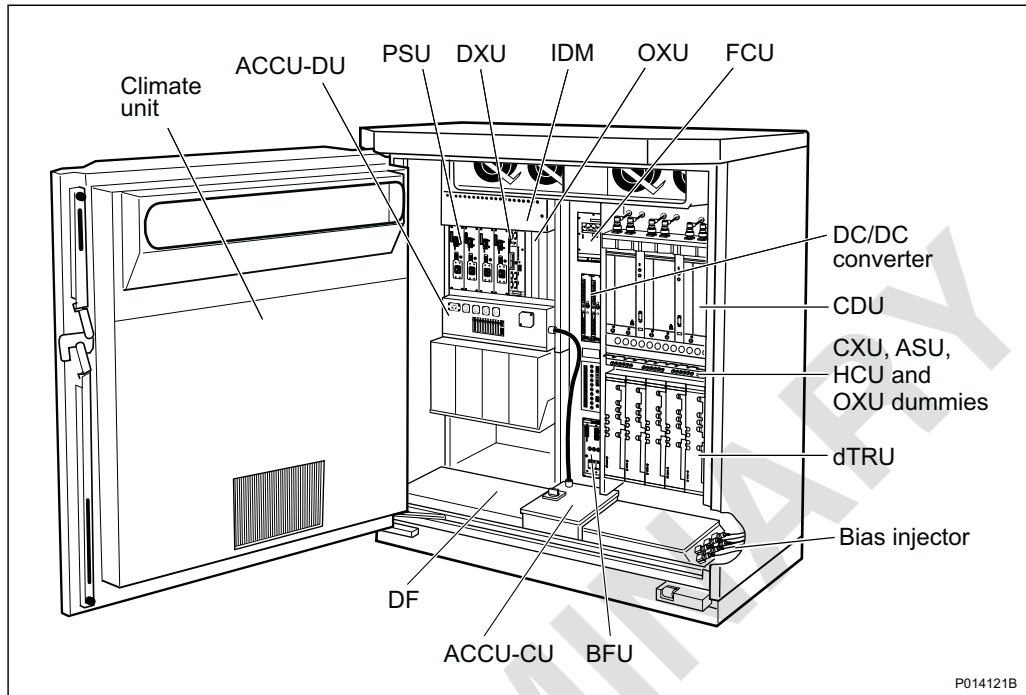

Figure 10 RBS 2106i Overview

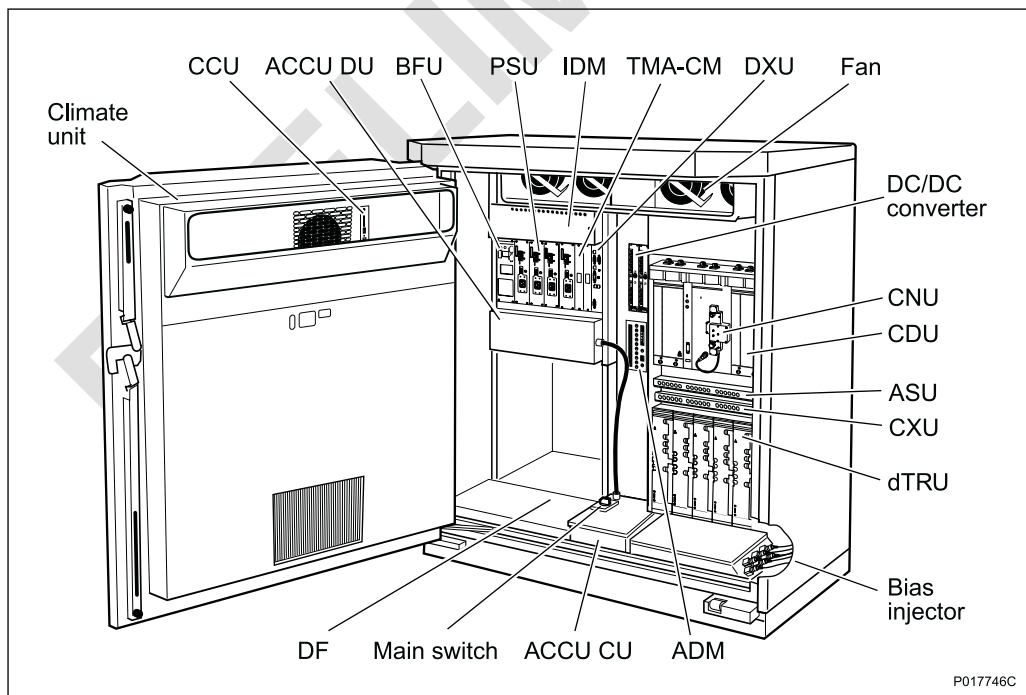

Figure 11 RBS 2106 V3 Overview

6.1 Standard Hardware Units

This section briefly describes the standard hardware units required for function, irrespective of configuration or frequency.

ACCU

The AC Connection Unit (ACCU) connects, disconnects, and distributes the incoming AC power supply to the PSUs and the climate unit. It consists of two parts: an ACCU Connection Unit (ACCU-CU) and an ACCU Distribution Unit (ACCU-DU). ACCU-02 is used in RBS 2106 and ACCU-05 is used in RBS 2106i and RBS 2106 V3.

Number of units: 1

BFU

The Battery Fuse Unit (BFU) supervises connection or disconnection of the batteries. It can also be used to provide prioritized power supply, for example, to the transmission equipment.

Two types of BFU are available: BFU 21 and BFU 32. BFU-21 is used in RBS 2106 and RBS 2106i. BFU-32 is used in RBS 2106 V3.

Number of units: 1

Climate Unit

The climate unit maintains the internal temperature and humidity inside the cabinet. The climate unit is mounted in the door of the cabinet.

Two types of climate units are available:

- Combined climate unit that provides cooling by use of heat exchanger and refrigeration units
- Heat exchanger climate unit that provides cooling by use of a higher efficiency heat exchanger unit.

Both types of climate units include heating elements and the heat exchanger function is DC powered.

Number of units: 1

CDU

The Combining and Distribution Unit (CDU) is the interface between the transceivers and the antenna system. All signals are filtered before transmission and after reception by means of bandpass filters. The CDU allows several dTRUs to share antennas.

The CDU combines transmitted signals from several transceivers, and distributes the received signal to several transceivers. The CDU supports EDGE. Three CDU types are used in the RBS 2106 to support all configurations:

- **CDU-F** is a filter combiner intended for high capacity solutions (baseband hopping only).

Number of units: 1 – 3

- **CDU-G** can be configured either for high capacity or for high coverage. It is a combiner that can be used for synthesizer or baseband hopping.

Number of units: 1 – 3

- **CDU-K** can be configured either for high capacity or for high coverage. It is a combiner that can be used for synthesizer or baseband hopping.

Number of units: 1 – 6

CXU

The task of the Configuration Switch Unit (CXU) is to cross-connect the CDU and the dTRU in the receiver path. The CXU enables a cabinet to be expanded or reconfigured without moving or replacing any RX cables.

The RX inputs/outputs on the dTRU and the CDU are positioned so that they minimize the number of cable types used to connect the CXU to the dTRUs and the CDUs.

The CXU is configured using software.

Number of units: 1 – 2

DF

The Distribution Frame (DF) is a connection and Overvoltage Protection (OVP) device for external alarms and PCM links. The DF protects equipment inside the RBS from overvoltage and overcurrent which can occur in external lines. Examples of equipment requiring OVP include transmission lines, ESBs and external alarms.

Number of units: 1

DXU

The Distribution Switch Unit (DXU) is the central control unit for the RBS. It supports the interface to the Base Station Controller (BSC), and it collects and transmits the alarms. The DXU controls the power and climate equipment for the RBS. It has a removable compact flashcard that enables replacement of a faulty DXU without the need to load RBS software from the BSC.

The DXU is provided with four connections for transmission interfaces. It can handle both 2,048 kbps (E1) and 1,544 kbps (T1) transmission interfaces. The DXU has hardware support for EDGE on 12 TRXs.

DXU-21 is used in RBS 2106 and RBS 2106i. DXU-23 is used in RBS 2106 V3.

Number of units: 1

dTRU

The double Transceiver Unit (dTRU) contains two TRXs used to transmit and receive two radio carriers.

It has a built-in combiner with the option to combine two TX signals into one TX output. It is also prepared for four-branch RX diversity for further improvements in sensitivity.

One version of the dTRU supports only GMSK and the other version supports GMSK, 8-PSK, 16-QAM and 32-QAM.

Number of units: 1 – 6

FCU

RBS 2106 and RBS 2106i include a Fan Control Unit (FCU) that controls the fans in the cooling system by regulating fan speed. The FCU is controlled by the DXU.

RBS 2106 V3 does not include an FCU as a hardware. Instead the fans are controlled directly from the DXU.

Number of units: 0 for RBS 2106 V3, 1 for RBS 2106 and RBS 2106i.

IDM

The Internal Distribution Module (IDM) distributes the internal +24 V DC power to the various units. Each distribution circuit in the cabinet is connected to a circuit breaker in the IDM.

Number of units: 1

PSU

The Power Supply Unit (PSU) converts 120 – 250 V AC to regulated +24 V DC.

Number of units: 2 – 4

6.2 Optional Hardware Units

This section describes the RBS 2106 optional hardware units.

ASU

The Antenna Sharing Unit (ASU) is a part of co-siting, that is, using another cabinet together with a GSM RBS 2106 cabinet in the same sector. The ASU allows a TDMA (or other) cabinet and a GSM RBS 2106 cabinet to share RX antennas.

Number of units: 0 – 1

ADM

The Auxiliary Distribution Module (ADM) handles distribution and fuse connection of system voltage (+24 V DC and –48 V DC) to the Transport Module (TM).

Number of units: 0 – 1

Battery Backup

Batteries can be installed inside the cabinet in either of the TM/BM spaces located to the left of the BFU. An external source of battery supply can also be used through the DC filter. If this is the case, then internal batteries can not be used.

Note: The maximum distance between the RBS and the BBS must not exceed 10 meters to prevent damage from, for example, lightning.

Bias injector

The bias injectors are used to provide the TMA with DC power from the TMA-CM, over the RX/TX feeder cables. In the RBS 2106, the bias injector is mounted between the antenna feeder and the CDU. In the RBS 2106i and RBS 2106 V3, the bias injector is mounted between the antenna feeder and the antenna connection field.

Number of units: 0 – 12

DC/DC Converter

The DC/DC converter can supply –48 V DC power to transmission equipment in the TM compartment. It converts +24 V DC to –48 V DC.

Number of units: 0 – 2

DC Filter

The DC filter is the interface between a +24 V DC external battery, and the IDM inside the RBS.

The DC filter has the following main functions:

- ElectroMagnetic Compatibility (EMC) filtering
- Connection of +24 V DC to the cabinet
- Distribution of +24 V DC power to the IDM

Number of units: 0 – 1

ddTMA

The ddTMA is to be mast-mounted and placed close to the antenna. It improves the receiver sensitivity. The ddTMA saves feeder cables by duplexing RX and TX signals to the same cable.

Number of units per cabinet: 0 – 6

ESB

TG synchronization is the technology used to expand one RBS 2106 cabinet with another RBS cabinet in the same cell. The External Synchronization Bus (ESB) is the cable connected between the DXUs.

Number of units: 0 – 1

Gas Collecting Kit

The acid leads can be supplied with a gas evaporating kit, which evacuates gases from the cabinet.

Number of units: 0 – 1

HCU

The HCU contains three hybrid combiners. Each hybrid combines two RF signals, delivered from the dTRU, into one.

Number of units: 0 – 1

OXU (RBS 2106 and RBS 2106i only)

The following Optional Expansion Unit (OXU) positions are available:

- Four spaces in the DXU/PSU subrack of the RBS 2106 and the RBS 2106i (RUs that are typically located in the OXU slots include the DXX and the TMA-CM)
- One 19-inch OXU position is available between the CXU and the CDU subrack (used for HCU and ASU in co-sited cabinets)

Smoke Detector

The smoke detector is an optical device. Its purpose is to detect visual smoke. When smoke enters the detector, a light beam is deflected towards a photocell and an alarm is activated.

Number of units: 0 – 1

Sound Hood

The sound hood attenuates noise from the climate unit, heat exchanger, and air condition.

Number of units: 0 – 1

TMA-CM

One or two Tower-Mounted Amplifier Control Modules (TMA-CM) can be used to provide ddTMAs with 15 V DC power through the bias injectors. It also identifies ddTMA faults and forwards this information to the alarm module in the RBS. If TMA-CMs are used, then they are installed in the DXU/PSU subrack.

Number of units: 0 – 2

TM

The Transport Module (TM) is a space in the cabinet reserved for transmission equipment. The RBS is type-approved with transmission equipment from Ericsson. Equipment from other manufacturers requires a new type approval for the RBS. It is the responsibility of the owner/operator to obtain the type approval. To ensure that the RBS function is not violated, the following is recommended:

- Any transmission equipment installed in the TM must fulfil the requirements in the Generic EMC standards IEC61000-6-3 and IEC61000-6-2
- All in/out interfaces (signal and power), which pass the cabinet border between two different EMC zones, must be sufficiently EMC-protected (transient protection, filtering)
- Shielded cables are recommended for connections between transmission equipment and the cabinet connection field, and between transmission equipment and the DXU or DXX.

The recommended installation is shown in the figure below.

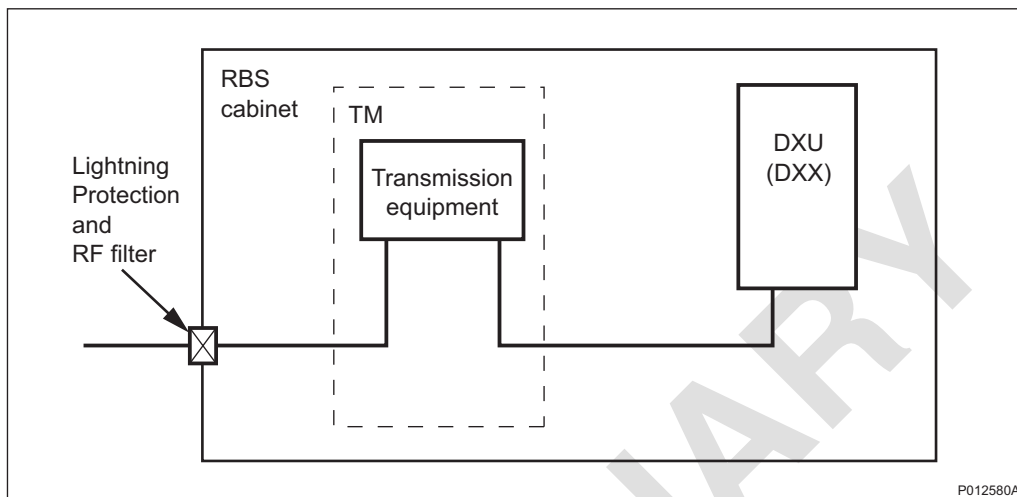

Figure 12 Recommended TM Installation

The maximum dimensions for the TM are shown in the table below.

Table 20 Maximum Dimensions

| Dimension | Size |
|---|--------|
| Panel width | 485 mm |
| Height | 445 mm |
| Depth behind mounting rails | 267 mm |
| Depth behind mounting rails | 280 mm |
| Space in front of mounting rails ⁽¹⁾ | 65 mm |

(1) For cables and connectors.

Note: The TM space is based on the 19 in. standard housing equipment.

The TM power distribution is shown in the table below.

Table 21 Power Distribution for the TM Space

| Type | Power |
|-----------------------|-----------------------|
| DC power distribution | 2 × 250 W at +24 V DC |
| | 2 × 200 W at -48 V DC |

Note: The maximum power distribution allowed in the TM space is 300 W.

The available airflow for cooling is 25 g/s (corresponding to approximately 80 – 85 m³/h) at a pressure drop of 60 Pa.

7 Interfaces

This section lists all external connectors, as well as the test interface and the operator interface.

Internal connections, the test interface, and the operator interface are located on some cabinet hardware units.

7.1 External Connections

All external connectors enter through the bottom of the cabinet. The approximate locations of the connection fields are shown in the figure below, to aid in planning cable inlet allowances.

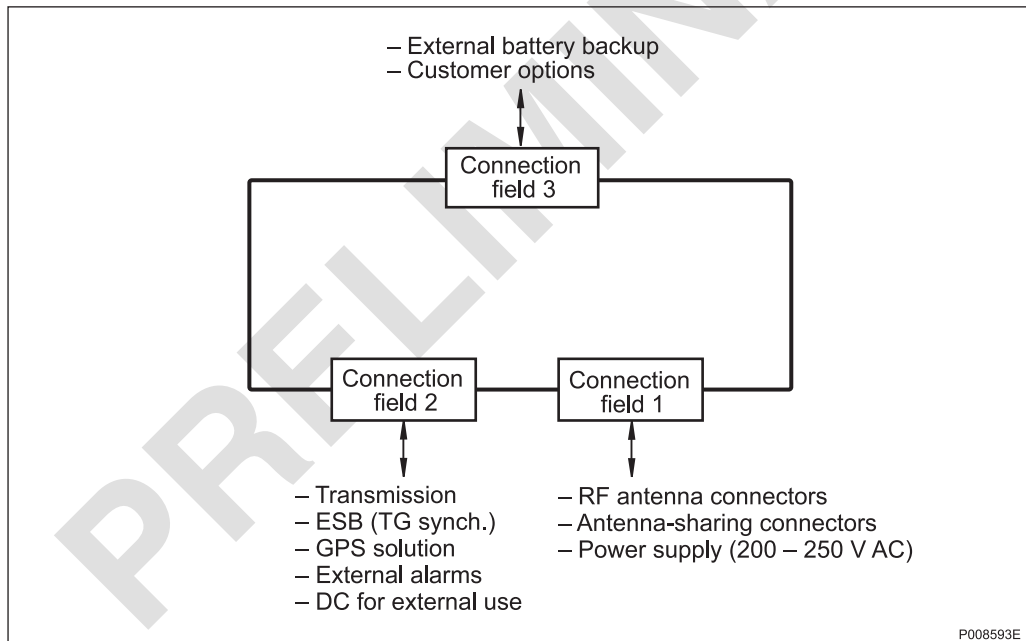

Figure 13 External Interfaces

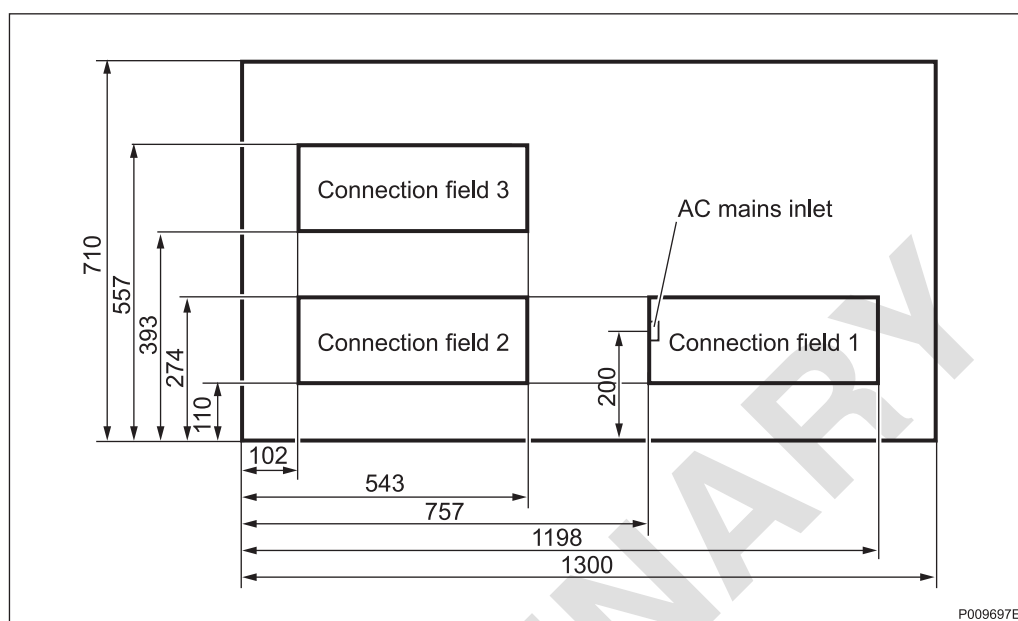

Figure 14 Cable Inlet Measurements

Table 22 Connection Field Inlets in RBS 2106i and RBS 2106 V3

| Connection Field | Cable | Inlet Diametre | Inlet Sealing Type |
|------------------|---------------|----------------------|--------------------|
| 1 | AC mains | 17 – 28 mm | Rubber |
| 2 | Signal cables | 6 × 10 mm, 18 × 5 mm | Rubber pads |
| 3 | Optical cable | 2 × 23 mm | |

Connections on DF

The DF, which is of modular construction, contains positions for OVP modules used for external alarms, GPS solution, PCM, and ESB cables.

Overvoltage Protection Modules in the RBS 2106i and RBS 2106 V3

The capacity of the OVP modules is shown in the table below.

Table 23 OVP Module Capacity

| Protected Unit | Capacity per OVP module |
|-----------------|-------------------------|
| PCM | 2 TX/RX pairs |
| ESB | 1 ESB (1 × 3 pairs) |
| External alarms | 4 alarms (4 pairs) |

Note: All connection points are spring terminal.

The DF in the RBS 2106i and RBS 2106 V3 can be equipped with the following:

- Up to two OVP modules for PCM (four PCM lines)
- Up to two OVP modules for ESB (one incoming and one outgoing)
- Up to four OVP modules for external alarms (16 external alarms)

Overvoltage Arrestors for External Alarms in the RBS 2106

All voltage arrestors, for example external alarms, have space for two alarms. The cable used must be single core, with a diameter of 0.3 – 0.8 mm.

Table 24 Overvoltage Arrestors

| Alarm | Connector |
|----------|-------------------|
| Alarm 1+ | OVP 1, terminal 4 |
| Alarm 1- | OVP 1, terminal 3 |
| Alarm 2+ | OVP 1, terminal 2 |
| Alarm 2- | OVP 1, terminal 1 |
| Alarm 3+ | OVP 2, terminal 4 |
| Alarm 3- | OVP 2, terminal 3 |
| Alarm 4+ | OVP 2, terminal 2 |
| Alarm 4- | OVP 2, terminal 1 |
| Alarm 5+ | OVP 3, terminal 4 |
| Alarm 5- | OVP 3, terminal 3 |
| Alarm 6+ | OVP 3, terminal 2 |
| Alarm 6- | OVP 3, terminal 1 |
| Alarm 7+ | OVP 4, terminal 4 |
| Alarm 7- | OVP 4, terminal 3 |
| Alarm 8+ | OVP 4, terminal 2 |
| Alarm 8- | OVP 4, terminal 1 |

Antenna Connections

The antenna connectors are accessible from the antenna connection box in the bottom of the cabinet. The intake plate in the bottom of the cabinet is equipped with six antenna cable connectors. These connections are shown in the figures and table below.

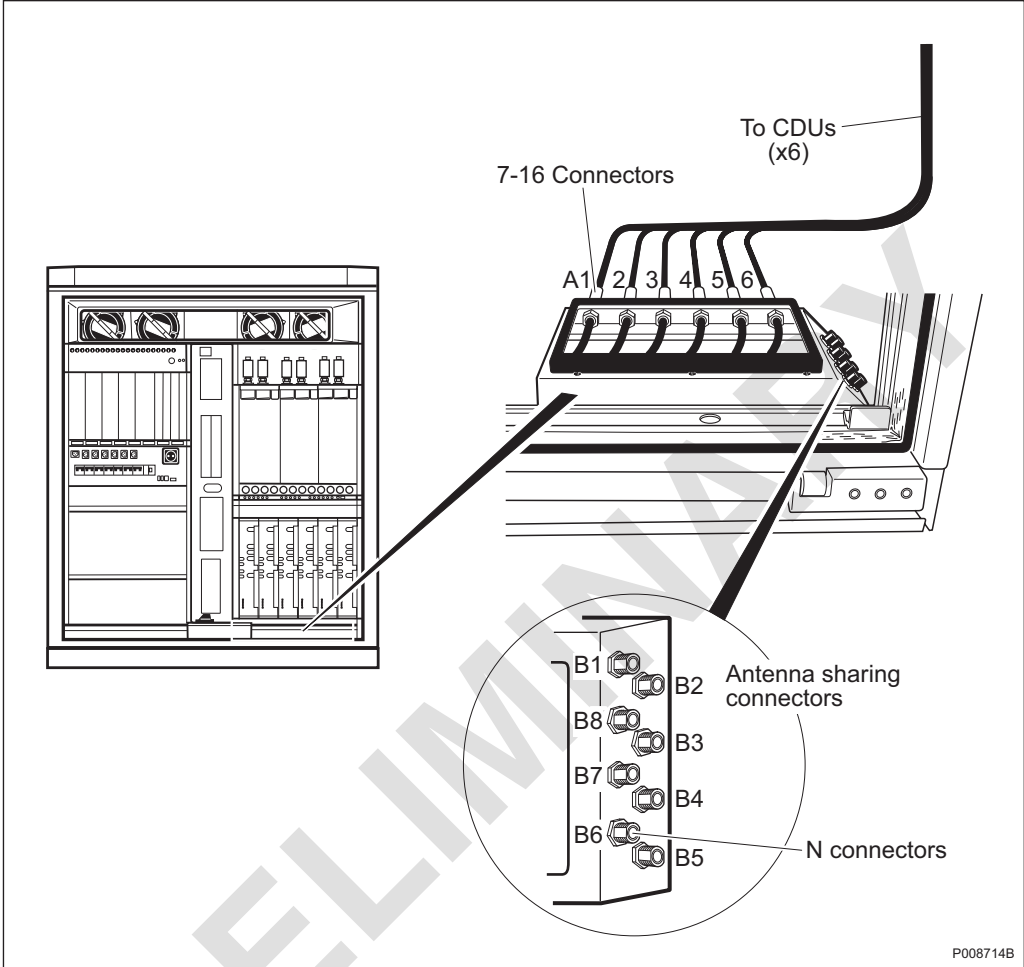

Figure 15 RBS 2106 Antenna Connections

P008714B

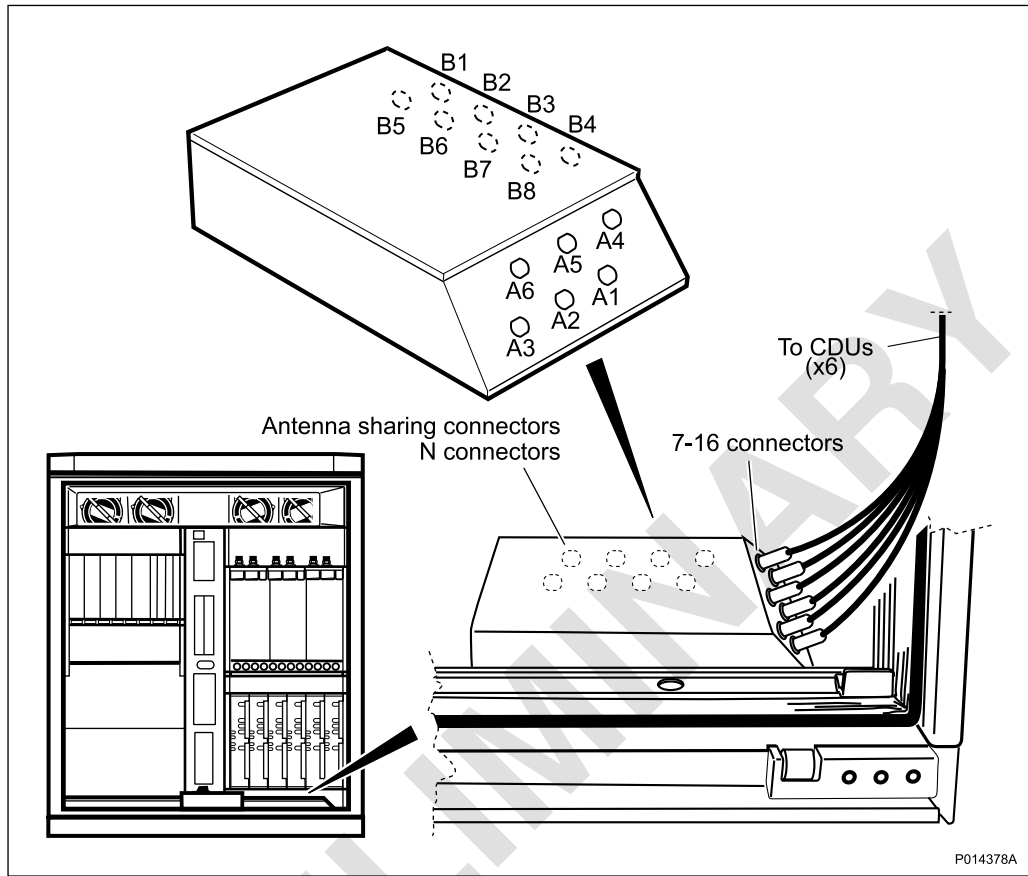

Figure 16 RBS 2106i and RBS 2106 V3 Antenna Connections

Table 25 Antenna Connections

| Connection Number | Connection To | Type Connector |
|-------------------|--|------------------------|
| A 1 – A 6 | Antenna | 7-16" IEC 169-4 |
| B 1 – B 6 | Antenna sharing | N connector IEC 169-16 |
| B 7 – B 8 | Optional | N connector IEC 169-16 |
| C 1 – C 6 | Antenna (only in CDU-K configurations) | 7-16" IEC 169-4 |

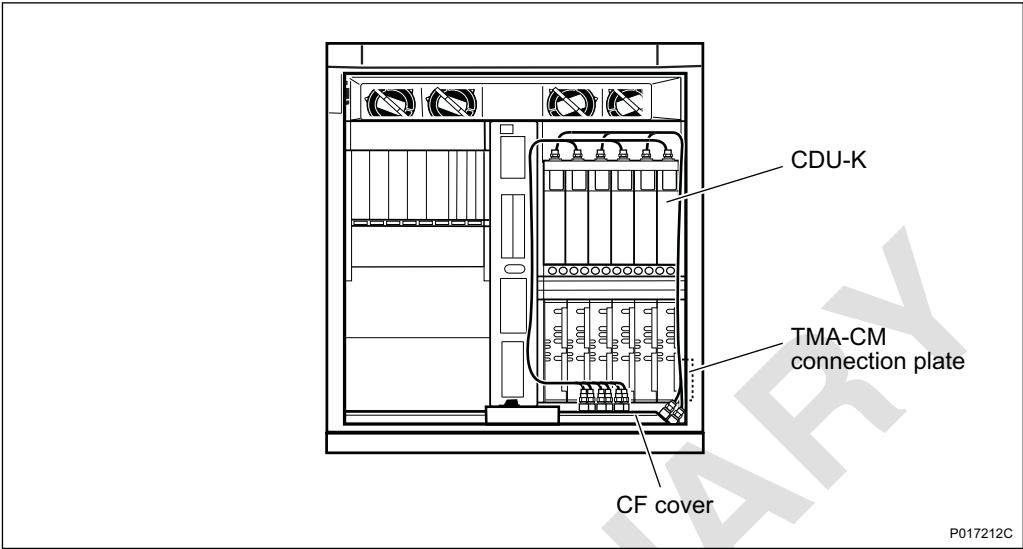

Figure 17 RBS 2106i and RBS 2106 V3 Antenna Connections with CDU-K

Other External Connections

Table 26 External Connections

| Connection Location | Connection To | Type Connector |
|---------------------|----------------------|---|
| AC connection box | AC Mains connections | Screw terminal for wires 4 – 16 mm |
| ACCU | AC Service outlet | <ul style="list-style-type: none"> • IEC 83:1975 standard C 2b (Sweden, Germany and others) • IEC 83:1975 standard B2, same as BS 1363:1984 standard 13A (UK) • IEC 83:1975 standard A5-15 (USA) |
| Reference earth | Earthing connection | M8 screw, 50 mm ² stranded copper wire |

External Connections to TM

Optical fibre and Mini-Link radio cables are connected to the TM through connection field 3. Twisted pair cables connect to the TM through the OVP.

Transport Network to TM

The external line from the transport network interfaces to the transport module. The type and impedance of the connector can differ from operator to operator.

7.2 Test Interface

The RBS 2106 is equipped with test interfaces for the connection of external equipment.

| | |
|---------------------|--|
| CLU | Self-test button |
| OMT | The Operation and Maintenance Terminal (OMT) interface is located on the front of the DXU. |
| System voltage test | The system voltage test port provides access to the system voltage (+24 V DC). It is located on the IDM. |

7.3 Operator Interface

The Man–Machine Interface (MMI) in the RBS 2106 consists of indicators and buttons located on the hardware units in the cabinet.

Indicators

Table 27 Optical Indicators

| Indicator | Position | Description |
|-------------------------|----------------------------------|---|
| Active cooler fan fault | Climate unit | A fan is faulty |
| Active cooler fault | Climate unit | The cooler is faulty |
| Bat disconnect | BFU | Battery disconnected |
| Battery mode | DXU | Indicates that the RBS is running on battery |
| EPC bus fault | All RUs connected to the EPC bus | Communication to superior RU is lost |
| External alarm | DXU | One or more supervised external alarms are active |
| Fan fault | FCU | A fan is faulty |
| Fault | All RUs | Fault detected and localized to the RU |
| Heater fault | Climate unit | The heater is faulty |

| Indicator | Position | Description |
|-----------------------------------|--------------|---|
| Heat exchanger external fan fault | Climate unit | A fan is faulty |
| Heat exchanger internal fan fault | Climate unit | A fan is faulty |
| Local mode | dTRU, DXU | The RU is in local mode |
| Operational | All RUs | The RU is operational |
| Power fault | Climate unit | AC or DC power is missing in the climate unit |
| RBS fault | DXU | One or more faults are detected on RUs in the RBS |
| RF off | dTRU | No RF signal |
| TMA operational | TMA | The TMA is operational |
| Transmission OK | DXU | Signal and frame synchronization OK |

Buttons

Table 28 Switches and Circuit Breakers

| Switch | Position | Function |
|----------------------|-----------|---------------------------------------|
| Battery disconnected | BFU | Disconnects the battery supply |
| Test button | CLU | CLU self-test |
| DC out | BFU | Automatic CB for DC out |
| DC out 1 | BFU | Automatic CB for DC out 1 |
| DC out 2 | BFU | Automatic CB for DC out 2 |
| DXU reset | DXU | Resets the DXU and all subunits |
| EC | BFU | Automatic CB for EC supply |
| Local/remote | DXU, dTRU | Changes mode between local and remote |
| Mains switch | ACCU | Mains switch for power supply |
| TMA/no TMA | ASU | Switch for TMA |
| TRU reset | dTRU | Resets the dTRU |

8 Power System

This section provides information on the power system of the RBS 2106.

The main characteristics of the RBS 2106 power supply are:

- Only Alternating Current (AC) mains supply is used
- Battery backup is optional and can be internal or external (but not both at the same time)
- The socket of the AC service outlet is available in four variants according to national standards

The figure below provides an overview of the power distribution system in the RBS 2106.

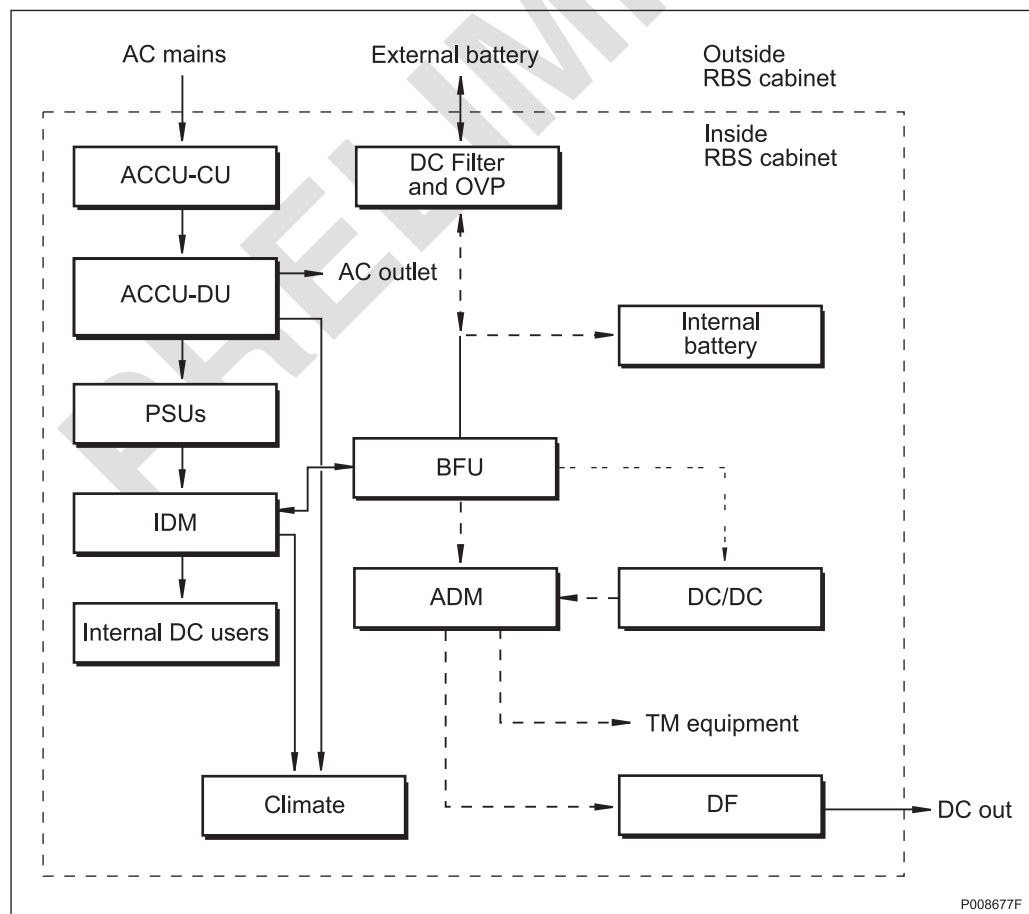

Figure 18 Power System

8.1 Power Supply

This section describes the AC mains power supply, the external earth fault circuit breakers, and the mains fuses.

AC Mains Supply Voltage

Single-phase, two-phase, or three-phase AC can be used.

Table 29 Power Parameters

| Parametre | Value |
|--|--|
| Nominal voltage | 200 – 250 V AC |
| Operating voltage | 180 – 275 V AC |
| Nominal frequency | 50 – 60 Hz |
| Operating frequency | 45 – 65 Hz |
| Maximum inrush current (total, all phases) | 60 A for 10 ms (typical duration) |
| PSU capacity | For RBS 2106 and RBS 2106i: 4 × 1200 W (4800 W total) For RBS 2106 V3: 4× 1500 W (6000 W total) |
| BFU | 1 × 200 A |
| BFU-32 | 1 × 300 A |

External Earth Fault Circuit Breakers

If external earth fault (ground fault) circuit breakers are used, then the recommended minimum trip value is 100 mA.

Mains Fuses

Table 30 Mains Fuses Recommendation

| Minimum for Safe Function | Recommended for Maximum Selectivity | Maximum Allowed Fuse Rating |
|---------------------------|-------------------------------------|-----------------------------|
| 25 A/40 A ⁽¹⁾ | 32 A/50 A ⁽¹⁾ | 63 A |

(1) Three-phase/Single phase.

8.2 Battery Backup

Battery backup is used to power the site during mains failure and also to protect the site from short-term interruptions in the mains supply. The backup time is dependent on for example RBS configuration, traffic load and temperature.

Internal Battery Backup

The following battery backup levels can be achieved in the cabinet:

- Full: one hour backup time
- Half: half an hour backup time

If no TM equipment is used, additional batteries can be installed in the TM compartment. The backup time will then be enhanced by 100%.

External Battery Backup

Ericsson supplies two external battery backup alternatives: the BBS or the BBU 9500. Both are connected through the DC filter.

Note: The maximum distance between the RBS and BBS must not exceed 10 meters to prevent damage from, for example, lightning.

8.3 Output Power to TM

The RBS can supply the TM with power according to the table below.

Table 31 Output Power

| | |
|-----------------------|---------------|
| –48 V DC | 2 × 200 W |
| +24 V DC | 2 × 250 W |
| –48 V DC and +24 V DC | 200 W + 250 W |

Note: Power to the transport module can be distributed to up to 10 internal users through the optional RU/ADM.

8.4 Power Consumption

The power consumption is shown in the table below.

Table 32 Maximum Power Consumption during Battery Charging

| RBS | Climate System | Power Consumption, Input Voltage >200 V AC |
|---------------|-----------------------------|--|
| 2106 or 2106i | Heat Exchanger Climate Unit | 5,570 W |

| RBS | Climate System | Power Consumption, Input Voltage >200 V AC |
|---------------|-----------------------------|--|
| 2106 or 2106i | Combined Climate Unit | 5,920 W |
| 2106 V3 | Heat Exchanger Climate Unit | 7,700 W |
| 2106 V3 | Combined Climate Unit | 8,700 W |

PRELIMINARY

9 Transmission

Transmission cables are normally connected to the transmission Overvoltage Protection (OVP) modules. Four transmission cables are connected to the ports on the front of the DXU. The RBS supports two transmission standards:

- T1 1544 kbps, 100 Ω
- E1 2048 kbps, 120 Ω
- E1 2048 kbps, 75 Ω

Optional Transmission Equipment

The cabinet can be connected to transmission equipment that is mounted externally or inside the RBS depending on the transmission equipment. Transmission equipment that can be used is as follows:

- AXX 9100 or OMS 860
- Mini-Link
- TMR 9202
- SIU-01

For more information about transmission equipment and configurations, see document Transmission Configurations and Installation, 151 86-EN/LZT 720 0460, for RBS 2106 and RBS 2106i or Transmission Configurations and Installation, 151 86-EN/LZT 720 0544, for RBS 2106 V3.

10 External Alarms

The RBS 2106 supports a maximum of 16 external alarms. The external alarm device can set the alarm using either an open or a closed condition.

The alarm device connected to the screw terminals must be isolated by relay contacts. A closed contact (logic zero) is required to be below 2 k Ω , and an open contact (logic one) above 100 k Ω . The current through a closed 0 W contact is 1.2 mA. The voltage between terminals with an open contact is +24 V DC.

The external alarms are defined during installation, using the OMT or from the BSC using the remote OMT.

Note: An installed DC/DC Converter is hard-coded to alarm input 16 in the external alarm unit. Pin 16 is therefore unavailable.

Note: An installed Smoke Detector is hard-coded to alarm input 2 and 3 in the External Alarm unit. Pins 2 and 3 are therefore unavailable.

11 Standards, Regulations and Dependability

This section provides a brief overview of standards, type approval, and EMC.

11.1 Safety Standards

In accordance with the market requirements, the RBS 2106 complies with the following product safety standards:

- 73/23/EEC Low voltage directive
- IP 55 according to IEC 60529
- EN 60950 / IEC 60950
- EN 60215 / IEC 60215
- UL 1950
- CSA 22.2 No. 950

11.2 Other Standards and Regulations

Marking

The product is marked with symbols to indicate compliance with product safety standards.

Type Approval Standards

The RBS complies with the European Community and the North America market requirements regarding radio performance. The product has the CE and FCC symbols to indicate compliance with the legal requirements of the respective region.

EMC

The RBS complies with the European Community and the North America market requirements regarding EMC. The product has the CE and FCC signs to indicate compliance with the legal requirements of the respective region.

Dependability

The RBS 2106 is designed for a technical lifetime of 25 years (24-hour operation). The following preventive maintenance conditions must be fulfilled to guarantee the availability of the RBS:

| | |
|--------------|--|
| Fans | The fans must be inspected (and cleaned if necessary) every year. The lifetime is estimated to be at least 7 years. |
| Climate Unit | The climate unit must be regularly inspected and cleaned (the interval is approximately one year, but depends on the environmental conditions at the site). |
| Batteries | The batteries must be regularly inspected every year (for oxide on the pole terminals). The batteries should be replaced according to the recommendations of the battery supplier. |

Vandal Resistance

The RBS 2106 fulfils Ericsson's requirements for vandal resistance.