

Prepared (also subject responsible if other) EAB/RWB/ZG Christina Wilson		No 18/1551-HRB 105 102/1 Uen		
Approved EAB/RWB/Z (Dennis Radenholt)	Checked	Date 2003-06-16	Rev B	Reference

Node Description

Contents		Page
1	Introduction	2
1.1	Purpose	2
1.2	Scope	2
2	Radio Network Overview	2
3	RBS Overview	4
4	Hardware Structure	5
4.1	Combined Baseband and Radio Frequency Subrack	6
4.2	MCPA	9
4.3	XALM	9
4.4	Capacitor Unit	9
4.5	Climate System	9
4.6	Internal Cables	10
4.7	Connections to the RBS	11
5	Node Architecture	11
5.1	Architectural Overview	11
5.2	Layered Views	12
6	Functions	14
6.1	Application Functions	14
6.2	Platform Functions	16
7	External Interfaces	16
7.1	Iub Interface	17
7.2	Uu Interface	17
7.3	Mub Interface	17
7.4	GUI	18
7.5	Visual and Mechanical Interface	19
8	Operation & Maintenance	19
8.1	Standard Operation	19
8.2	Alarms	20

Prepared (also subject responsible if other) EAB/RWB/ZG Christina Wilson	No 18/1551-HRB 105 102/1 Uen		
Approved EAB/RWB/Z (Dennis Radenholt)	Checked Date 2003-06-16	Rev B	Reference

1 Introduction

This document describes Radio Base Station (RBS) 3104 in a Radio Access Network (RAN) that uses Wideband Code Division Multiple Access (WCDMA) technology. The RBS 3104 is intended for outdoor use.

1.1 Purpose

This document is intended as a first level introduction to the RBS for network operations and maintenance (O&M) personnel.

1.2 Scope

The document gives a brief description of the different nodes in the RAN and a detailed description of the RBS.

For further information, see :

- page 2
- page 4
- page 5
- page 11
- page 14
- page 16
- page 19

2 Radio Network Overview

This section gives an overview of the Radio Network in which the RBS is a part. figure 1 shows the parts of the Radio Network.

Prepared (also subject responsible if other) EAB/RWB/ZG Christina Wilson		No 18/1551-HRB 105 102/1 Uen	
Approved EAB/RWB/Z (Dennis Radenholt)	Checked	Date 2003-06-16	Rev B
		Reference	

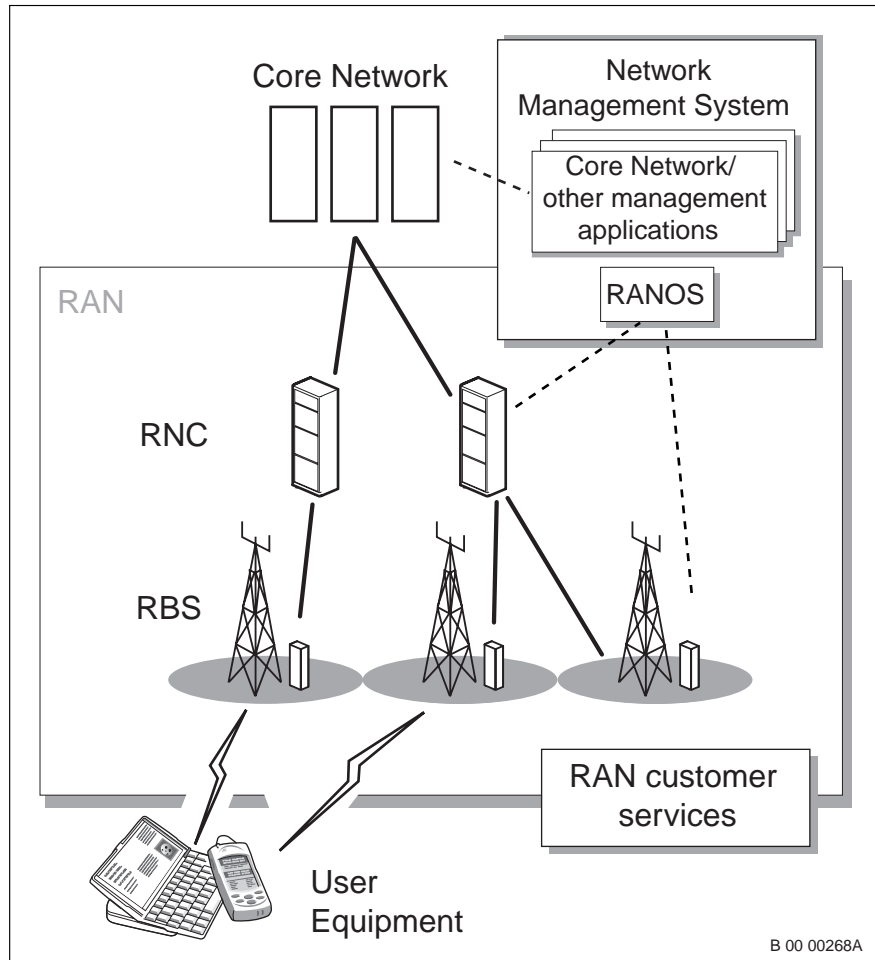

Figure 1 Radio Network Overview

The Radio Network consists of the following parts:

Core Network

The Core Network (CN) provides call control as well as mobility for, and localization of, the User Equipment (UE). The CN also interacts with the RNC and provides support for network features and telecommunication services. The CN handles both packet-oriented services, such as data, and circuit-oriented services, such as speech.

RAN

The RAN provides the connection between the CN and the UE. The RAN also comprises interfaces towards different management systems. The RAN consists of the RNC and the RBS.

- The RNC interacts with the CN as well as the RBSs and manages radio links. The RNC also controls mobility and optimizes the radio network

Prepared (also subject responsible if other) EAB/RWB/ZG Christina Wilson	No 18/1551–HRB 105 102/1 Uen		
Approved EAB/RWB/Z (Dennis Radenholt)	Checked Date 2003-06-16	Rev B	Reference

resources. A single RNC can handle one or more RBSs and an RNC can work with other RNCs to increase capacity.

For detailed information about the RNC, see *Node Description, RNC 3810, 6/1551-AXD 10503/1*.

- The RBS provides radio resources and handles radio transmission and reception to and from the UE.

RANOS

RANOS is one of the network management systems the operator can use. RANOS is used to handle O&M tasks such as alarm handling, configuration and performance monitoring.

It is possible to integrate RAN with existing network management systems.

3

RBS Overview

The following section is a brief introduction to the RBS.

Common Platform

The RBS hardware and software are based on a common platform used both in RBS and RNC. From this platform it is possible to create an Asynchronous Transfer Mode (ATM) cell-switching network node. The common platform consists of an ATM transport system, a distributed real-time telecommunication control system, and an element management system built with Java technology.

Hardware

The RBS comprises one cabinet with a subrack for plug-in units. Other units are a Climate Unit, a Fan Unit, a Capacitor Unit, a Connection Field and a Power Distribution Unit.

Software

The RBS software architecture consists of two layers: the Common Platform Layer and the Application Program Layer:

- The Common Platform Layer provides basic support for the application program and includes the operating system and provides support for ATM transport, and O&M.
- The application program runs on top of the Common Platform Layer and defines the RBS functionality.

A Main Processor (MP) and subordinate Board Processors execute the RBS software.

Prepared (also subject responsible if other) EAB/RWB/ZG Christina Wilson	No 18/1551–HRB 105 102/1 Uen		
Approved EAB/RWB/Z (Dennis Radenholt)	Checked Date 2003-06-16	Rev B	Reference

RBS Main Services and Functions

The RBS provides radio resources for the RAN. It provides radio transmission and reception in one cell. The RBS functionality is subdivided into traffic and O&M functions:

- The traffic related functions handle the user data traffic and control communication with the RNC and the UE. This also includes the handling of cells, transport channels, and ATM links.
- The O&M functions ensure that the system becomes and remains operational, handles equipment malfunctions, and monitors the RBS performance.

RBS Characteristics and Configurations

For detailed information on product safety, product data and environmental characteristics, please refer to *Health and Safety Information, RBS 3104, 7/12446–HRB 105 102* and *Product Data RBS 3104, 1/1553–COH 109 392*.

The RBS has a modular architecture with scalable capacity. For detailed information on different RBS configurations, please refer to *Configuration Data RBS 3104*.

4 Hardware Structure

This section describes the units, the climate system, the internal cables and the connection field in the RBS 3104.

An RBS 3104 consists of a single cabinet configured to handle one Radio Frequency carrier in one sector.

The cabinet contains a subrack that can be equipped with several plug in units (PIU) depending on configuration and various traffic and transmission capacities. The location of the subrack, the climate system and other modules in the cabinet is shown in figure 2.

Prepared (also subject responsible if other) EAB/RWB/ZG Christina Wilson	No 18/1551-HRB 105 102/1 Uen
Approved EAB/RWB/Z (Dennis Radenholt)	Checked Date 2003-06-16
	Rev B
	Reference

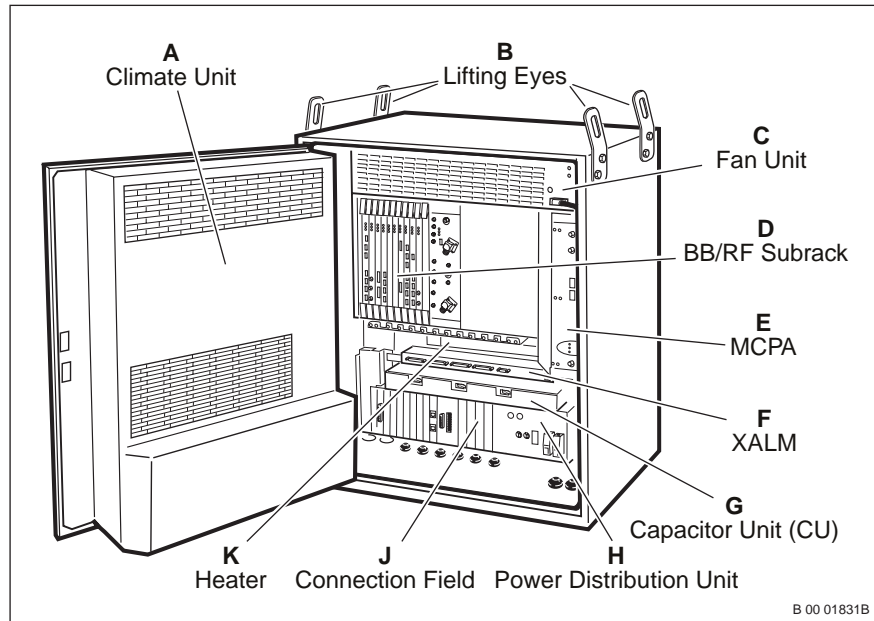

Figure 2 RBS 3104, hardware

The letters in the figure above denote:

Table 1 RBS 3104 main components

Pos.	Unit	
A	Climate Unit, <i>see chapter 4.5</i>	
B	Lifting Eyes	
C	Fan Unit, <i>see chapter 4.5</i>	
D	BB/RF Subrack	Base Band/Radio Frequency Subrack, <i>see chapter 4.1</i>
E	MCPA	Multi Carrier Power Amplifier, <i>see chapter 4.2</i>
F	XALM	External Alarm Unit, <i>see chapter 4.3.</i>
G	CU	Capacitor Unit, <i>see chapter 4.4</i>
H	Power Distribution Unit, <i>see chapter 4.7</i>	
J	Connection Field <i>see chapter 4.7</i>	
K	Heater, <i>see chapter 4.5</i>	

4.1 Combined Baseband and Radio Frequency Subrack

The combined BB/RF subrack is based on a common platform. The Switch Core Board (SCB) uses the ATM protocol for communication via the backplane

Prepared (also subject responsible if other) EAB/RWB/ZG Christina Wilson	No 18/1551-HRB 105 102/1 Uen		
Approved EAB/RWB/Z (Dennis Radenholt)	Checked Date 2003-06-16	Rev B	Reference

within the subrack. The subrack's BB and RF parts are connected to each other through the BB Interface Board (BBIFB) and the RF Interface Board (RFIFB) carrying the downlink and uplink traffic streams.

The BB/RF subrack comprises an Iub interface connection with an RNC, the MP cluster, and the baseband and radio frequency functionality.

Baseband functionality consists of:

- Encoding and decoding of transport channels
- Spreading of bits
- Combining of channels
- Reception through a rake receiver
- Searching and random access processing

The RF part contains all the RF processing hardware, except for the power amplifiers. It takes care of:

- D/A and A/D conversion
- RF modulation and demodulation
- RF carrier combining and splitting
- Low noise amplification for reception

The following sections give a brief description of the boards in the subrack.

4.1.1 Baseband Boards

ETB

The Exchange Terminal Board (ETB) provides the connections for the Iub and remote Mub interfaces. It serves as an interface between the transmission cables and the Asynchronous Transfer Mode (ATM) switch on an SCB. The type of ETB(s) depends on the transmission standard.

SCB

The Switch Core Board (SCB) contains an ATM switch and interfaces to the ATM switch ports located on other boards via the backplane.

The SCB also has a connector and filter for the system power. The system power is distributed within the subrack via the backplane.

RAXB

The Random Access/Receiver Board (RAXB) comprises the baseband receiver part, which takes care of decoding, searching and rake receiving for dedicated and random access transport channels, and cell combining for softer handover.

Prepared (also subject responsible if other) EAB/RWB/ZG Christina Wilson	No 18/1551-HRB 105 102/1 Uen		
Approved EAB/RWB/Z (Dennis Radenholt)	Checked Date 2003-06-16	Rev B	Reference

With an optional RAXB it is possible to share the load to achieve high availability. If one RAXBs fails, the load is moved to the remaining RAXB.

GPB

The General Processor Board (GPB) operates as an MP and contains and executes the main part of the RBS software. It controls devices on boards and in auxiliary units. The GPB has flash disk storage, an Ethernet connection and an RS232 interface.

TXB

The Transmitter Board (TXB) comprises the baseband transmitter part for handling transport channels, encoding, cell splitting, modulating and spreading, and channel combining.

TUB

The Timing Unit Board (TUB) generates and distributes local timing signals.

BBIFB

The Baseband Interface Board (BBIFB) connects the baseband part of the BB/RF subrack to the RF part of the BB/RF subrack. The connection carries the downlink and uplink traffic streams, and timing signals.

4.1.2 Radio Frequency Boards

AIU

The Antenna Interface Unit (AIU) consists of a filter and control unit, and a combiner and splitter unit. The filter and control unit provides the following:

- Duplex filtering of the transmitter and receiver signal
- Low-noise amplification of the receiver signal
- Power measurement of the transmitter signal
- Flexible frequency and signal splitting

RFIFB

The Radio Frequency Interface Board (RFIFB) connects the RF part of the BB/RF subrack to the baseband part of the BB/RF subrack. The connection carries the downlink and uplink traffic, and timing signals. The RFIFB also performs power clipping for downlink traffic.

TRXB

The Transceiver Board (TRXB) provides channel filtering, delay and gain adjustment, A/D and D/A conversion, and RF modulating and demodulating. A TRXB comprises two independent transceivers for two transmitter and receiver signal pairs.

Prepared (also subject responsible if other) EAB/RWB/ZG Christina Wilson	No 18/1551-HRB 105 102/1 Uen		
Approved EAB/RWB/Z (Dennis Radenholt)	Checked Date 2003-06-16	Rev B	Reference

4.2 MCPA

The MCPA is a 20 W RF power amplifier with a bandwidth of 20 MHz. The MCPA can simultaneously amplify, in RBS 3104, up to two RF carriers, by dividing the power over the carriers.

The MCPA subrack is connected to the RF subrack through front panel cabling.

4.3 XALM

The XALM handles the customer specific alarms as well as alarms for Ericsson equipment, such as door alarm.

4.4 Capacitor Unit

The Capacitor Unit (CU) receives the -48 V DC supply, which powers the RBS. The CU ensures that the RBS remains in operation during short transient drop of power. The CU smooths out irregularities in the supplied power, and the unit is subdivided into three electrically separated sections.

4.5 Climate System

The climate system comprises the Climate Unit (CLU) in the cabinet door, a Fan Unit in the cabinet, and a Heater in the cabinet. The CLU comprises the two External Fans, a Heat Exchanger (H/E) and an Active Cooler (A/C).

At low ambient temperatures, only the H/E operates to cool the cabinet. The Heater is used during start up at low ambient temperatures to ensure that the temperature inside the cabinet rises above a certain level. The Heater and A/C are interlocked to prevent them from operating at the same time.

At high ambient temperatures, the A/C contributes to maintain sufficiently low cabinet temperatures.

The H/E and A/C co-operate to ensure that long time average power consumption is minimized.

Climate Unit

The Climate Unit (CLU) is a cooling device that includes a Heat Exchanger, an Active Cooler, a compressor control unit, and the External Fans. The speed of the External Fans is temperature controlled.

The H/E consists of a counter-flow H/E with external air circuit fans.

The A/C consists of compressor, reducing valve, condenser and evaporator.

Heater

The Heater is DC supplied and is controlled by a thermostat to avoid overheating.

Prepared (also subject responsible if other) EAB/RWB/ZG Christina Wilson	No 18/1551-HRB 105 102/1 Uen		
Approved EAB/RWB/Z (Dennis Radenholt)	Checked Date 2003-06-16	Rev B	Reference

Fan Unit

The Fan Unit contains the Internal Fans and the Climate System Control Unit. The Fan Unit is accessible from the front of the cabinet. The speed of the Internal Fans is temperature-controlled.

4.6

Internal Cables

This section gives a brief description of the internal RBS cables.

Gamma Cable

The gamma cables connect the BBIFB and RFIFB. The BBIFB and RFIFB can connect two gamma cables, one for each antenna branch. It carries serial traffic streams from the gamma interface.

Timing Cable

The timing cable is a connection between the BBIFB and RFIFB. This cable connection distributes timing signals from the BB part of the subrack to the RF part of the subrack, and reads RFIFB product information.

Inter-Subrack Timing Cable

The inter-subrack timing cable distributes timing signals from the TUB to the RF part. The cable is connected between the BBIFB and the RFIFB.

Internal Jumper Cable

The internal jumper cables connect the AIU to the RF connectors at the bottom of the RBS cabinet. As the AIU can handle two antenna branches, two cables are connected to the AIU. These cables carry the transmit RF and receive RF signals.

For Antenna Near Products, the AIU can feed power through both cable connections. One of the antenna connectors also has the capability to carry the auxiliary unit interface, which supervises and controls units.

MCPA Control Cable

The MCPA control cable is the auxiliary unit control connection for the MCPA. The cable is connected between the RFIFB and MCPA.

Low-Power Multi-Carrier TX Cable

The low-power multi-carrier Transmitter (TX) cable carries the low power RF signal after carrier combination and signal splitting (if applicable) from the AIU to the MCPA.

High-Power TX Cable

The high-power Transmitter (TX) cable carries the RF signal from the MCPA to the AIU after power amplification.

Transmission Cable

The transmission cable connects the ETB to the Connection Field at the bottom of the RBS cabinet.

Prepared (also subject responsible if other) EAB/RWB/ZG Christina Wilson	No 18/1551-HRB 105 102/1 Uen		
Approved EAB/RWB/Z (Dennis Radenholt)	Checked Date 2003-06-16	Rev B	Reference

Site LAN Connection Cable

The Site LAN connection cable connects the GPB to the Site LAN panel in the connection field.

XALM Interface Cable

The XALM interface cable connects the SCB to the XALM.

Low-Power Single Carrier TX Cable

The low-power single carrier TX cable connects the TX output of the TRXB to the AIU.

Fan Unit Cable

The fan unit cable connects the Fan Unit to the Climate Unit and is used for power feeding, control of the fans and supervision.

4.7 Connections to the RBS

This section gives a brief description of the connections to the RBS.

Site LAN Connection

The Site LAN connection is an Ethernet based interface for connecting the thin client used for O&M or for connection to site equipment.

- 48 V DC Connection

-48 V DC is connected to two terminal blocks on the Power Distribution Unit.

External Alarms

Four external alarms can be connected to the alarm panel.

Transmission Lines

The fibre optic transmission is connected directly to the ETB1 board. The twisted pair cable transmission is connected to an optional OVP module in the connection field.

RF Connectors

RF connectors are located at the bottom of the cabinet, on the left hand side.

5 Node Architecture

5.1 Architectural Overview

The functionality is subdivided into two parts that operate on the infrastructure and a common platform. The two parts are:

- Control plane functionality, featuring traffic control and O&M, and

Prepared (also subject responsible if other) EAB/RWB/ZG Christina Wilson		No 18/1551-HRB 105 102/1 Uen		
Approved EAB/RWB/Z (Dennis Radenholt)	Checked	Date 2003-06-16	Rev B	Reference

- User plane functionality, featuring transport, baseband, radio and antenna near parts functionality.

figure 3 shows the general RBS software architecture.

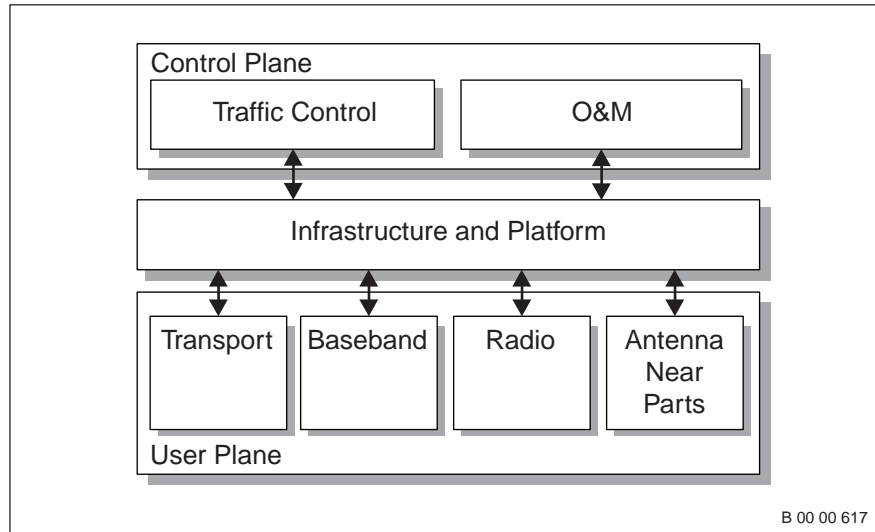

Figure 3 Architectural Overview

5.2 Layered Views

There are three important views of an RBS node, each showing a specific aspect and containing several layers:

- Platform View, *see page 12*
- Traffic control view, *see page 13*
- Management view, *see page 13*

Platform View

The platform view consists of two layers:

- The common platform layer isolates the application program layer from the implementation details of the processor and ATM platform. This makes it possible to change the processor and ATM parts without having to modify the application program.

A standard web browser is used for RBS management through the element manager. The platform layer supports the Element Manager (EM) by providing common platform support functions such as a graphical interface, Java applet communication and online context sensitive help.

Prepared (also subject responsible if other) EAB/RWB/ZG Christina Wilson	No 18/1551–HRB 105 102/1 Uen		
Approved EAB/RWB/Z (Dennis Radenholt)	Checked Date 2003-06-16	Rev B	Reference

- The application program layer is the software executing on top of the common platform. So, from the platform point of view, there is no specific structure for the application program.

Traffic Control View

This view hides the specific RBS hardware from the actual services supplied by the RBS. This is done to encapsulate the parts of the system that change when hardware is modified. Modification normally takes place when an RBS is updated (for example, capacity increase) or when different types of RBSs are supported.

There are four layers in the traffic control view:

- Traffic service layer that carries out the application program procedures using logical resources, for example, channels.
- Logical resource layer that provides logical resources for the traffic service layer. It transforms operations on logical resources into operations on devices.
- Equipment layer that makes functionality hardware independent by providing devices to logical resource layer.
- Hardware layer that hides the hardware details.

Management View

The management view covers the application program and the common platform. It hides implementation details from the user interface.

There are three layers in the management view:

- The presentation layer holds the GUI, which consists of, for example, HTML pages and Java applets. They include, for example, workflow-oriented forms for system configuration and support for reading and presenting an event log. The presentation layer is implemented using web pages and applets, which can be viewed using a standard web browser.
- The management adaptation layer represents objects visible through the Mub management interface. These objects contain attributes, that can be read or written, and methods for operations on these objects through the standard web browser.
- The resource layer hides the lower level implementation details of the objects, which reduces the impact of changes.

Fault detection functions in the resource layer, and also in the common platform, ensure fault and error detection. The hardware layer within the resource layer provides fault and error detection support on a low level. However, it has no direct interface to the management adaptation layer. The management adaptation layer and the common platform generate the corresponding alarms. Events can have their origin in any part of the system, but the management adaptation layer and the common platform generate the event reports.

Prepared (also subject responsible if other) EAB/RWB/ZG Christina Wilson		No 18/1551-HRB 105 102/1 Uen		
Approved EAB/RWB/Z (Dennis Radenholt)	Checked	Date 2003-06-16	Rev B	Reference

6 Functions

The RBS functions can be subdivided into RBS application functions and common platform functions. RBS application functions use common platform functions to realize their tasks. An overview of the main RBS application function groups and their interfaces is given in figure 4. The interfaces are described in page 16.

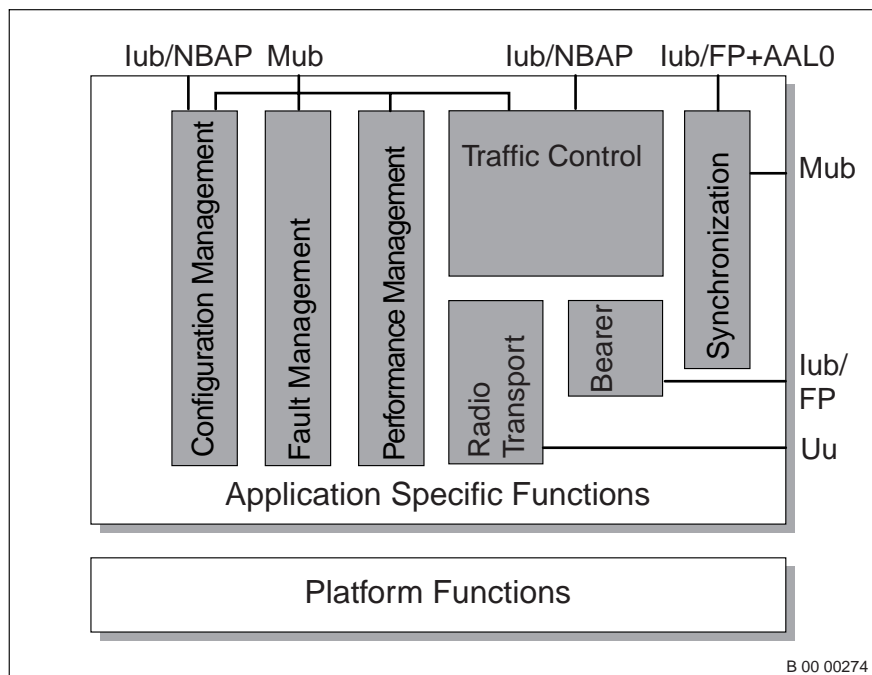

Figure 4 Main RBS Application Function Groups

Measurement functionality is subdivided into a detector part (normally in radio transport functions) and a control part, that controls the measurement. Measurement functions have different roles in the measurement functionality.

The O&M for traffic control functions is included within the function itself. Security aspects are handled within each function that interfaces with the Mub. Security support is provided by the platform functions.

Functions that have an interface for management only cover functionality towards an Mub user. The Mub user can be either an element management node or RANOS.

6.1 Application Functions

The application functions of the RBS are subdivided into function groups each covering some specific RBS functionality. See table 2 for RBS function groups.

Prepared (also subject responsible if other) EAB/RWB/ZG Christina Wilson	No	18/1551-HRB 105 102/1 Uen	
Approved EAB/RWB/Z (Dennis Radenholt)	Checked	Date 2003-06-16	Rev B
		Reference	

Table 2 RBS Function Groups

Function group	Task
Fault Management	Fault management functions detect, isolate, and recover from faults in supervised functions. Faults are reported through alarms, that also are logged and maintained in an active alarm list. Alarm handling is performed through the Mub interface. Supervision functions are always active and do not have to be configured.
Configuration Management	Configuration management functions create and delete RBS Managed Objects (MO). Attributes of these MOs can be set and read. These functions are performed over the Mub interface. Some functionality also exists that uses the lub interface.
Performance Management	Performance management functions collect, store and report statistics regarding RBS measurements. These functions are performed through the Mub interface.
Traffic Control	Traffic control functions provide control of traffic-related resources such as common and dedicated radio connections, cells and ATM connections. The functions also provide control of measurement requested from the RNC. Traffic control is performed through the lub interface and is managed over the Mub interface.
Radio Transport	Radio transport functions manage user data processing in the baseband and RF parts of the RBS node. It handles the air interface Uu. Measurement detector functionality is also included.
Bearer	Bearer functions transfer user or control data between the RNC and the RBS. The data is carried over the lub interface.
Synchronization	Synchronization functions provide correct data timing, and prevent data loss due to slip of sent and received information through the system. The functions also provide stable frequency references for RF stabilization. Synchronization functions are managed through the Mub interface. Synchronization frames are carried over the lub interface to and from RNC.
Infrastructure	Infrastructure functions handle power feeding, environmental control and basic infrastructure software functionality. These functions are managed through the Mub interface.
GUI	This function group contains the GUI functionality. The user interface handles the GUI.

Prepared (also subject responsible if other) EAB/RWB/ZG Christina Wilson		No 18/1551-HRB 105 102/1 Uen		
Approved EAB/RWB/Z (Dennis Radenholt)	Checked	Date 2003-06-16	Rev B	Reference

6.2 Platform Functions

The Platform contains all the functionality necessary to switch ATM cells and variable length cells (that is, ATM Adaptation Layer type 2 (AAL2) Common Part Sublayer (CPS) packets) within an ATM-based telecommunications network.

It also includes CCITT Signalling System number 7 (SS7) support (Signalling Connection Control Protocol (SCCP) Message Transfer Part layer 3 broadband (MTP3b) as well as functionality for network signalling using Q.2630.1 for AAL2 connections.

7 External Interfaces

Communication to and from the RBS is made through the Iub, Uu and Mub interfaces. Besides these interfaces the RBS also provides a management GUI that uses the Mub, and a Visual and Mechanical Interface (VMI), which comprises indicators, switches, buttons, cables, and so on. An overview of the external interfaces is given in figure 5. Descriptions of the interfaces are given below.

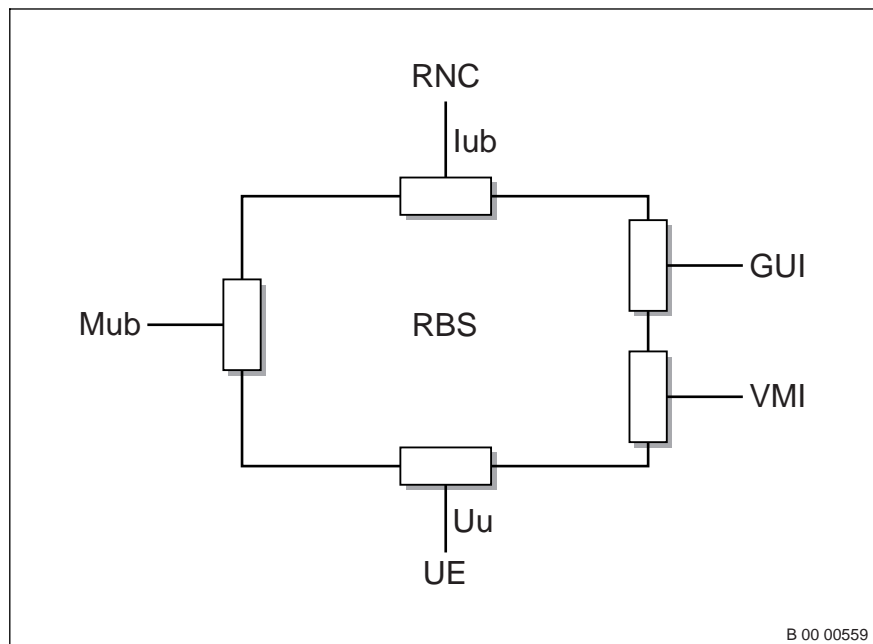

Figure 5 External Interfaces

Prepared (also subject responsible if other) EAB/RWB/ZG Christina Wilson	No 18/1551-HRB 105 102/1 Uen		
Approved EAB/RWB/Z (Dennis Radenholt)	Checked Date 2003-06-16	Rev B	Reference

7.1 lub Interface

The lub interface is the interface between the RBS and the RNC. The lub is subdivided into several protocol layers as follows:

- Physical layer (L1)
- ATM and ATM adaptation layers (L2)
- Network layer (L3) for frame handling

The L3 protocol for the RNC plane is called NBAP. The L2 and L3 part of air interface channels RACH, FACH, PCH and DCH terminate in the RNC.

From an RBS perspective, the different air interface channels are all treated as transparent user plane channels.

7.2 Uu Interface

The Uu interface is the radio interface between RBS and the UE. The radio interface is subdivided into three protocol layers as follows:

- Physical layer (L1)
- Data link layer (L2)
- Network layer (L3)

The L2 comprises of Medium Access (MAC) and Radio Link Control (RLC). The MAC provides unacknowledged transfer of SDUs between peer MAC entities, and the RLC provides data transfer of SDU and can also support the retransmission protocol.

L3 comprises the Radio Resource Control (RRC), which interfaces with L2

7.3 Mub Interface

The Mub is the management interface for the RBS and, in contrast to the lub, is not standardized. The interaction between the system and a user is realized by means of a thin client. The thin client is a computer with basic software, such as a web browser, installed. The thin client gets software that is dependent on the managed node by loading Java applets from the node at execution time.

The Mub is based on IP, so the RBS has an IP address. Remote management uses IP over ATM and on-site management uses Ethernet. The necessary low-level communication layers including FTP server, HTTP server, ORB and Telnet server are provided by the common platform.

The management interfaces are shown in figure 6.

Prepared (also subject responsible if other) EAB/RWB/ZG Christina Wilson		No 18/1551-HRB 105 102/1 Uen	
Approved EAB/RWB/Z (Dennis Radenholt)	Checked	Date 2003-06-16	Rev B
		Reference	

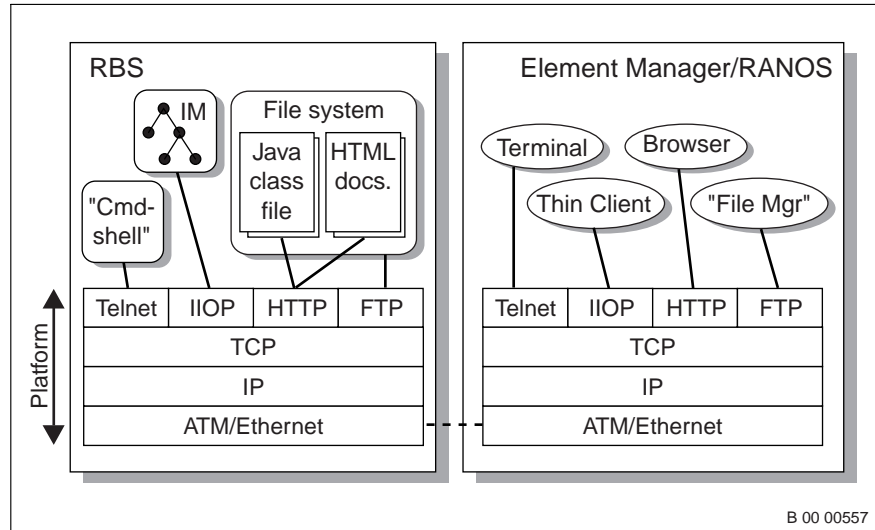

Figure 6 Management Interfaces

- Telnet** Telnet provides local and remote access to the operating system shell in the RBS. The command line interface provides a set of commands handled by a Unix shell-like command interpreter.
- IIOp** IIOp (IP based Inter-ORB Protocol) is the protocol used in Common Object Request Broker Architecture (CORBA). It is the main protocol used for RBS O&M. The element manager and the network manager (RANOS) use the protocol.
- HTTP** HTTP transfers HTML documents such as online documentation and Java applets from the file system in the RBS node to a managing system.
- FTP** FTP transfers files to and from the file system in the RBS. This is primarily used for loading software, configuration data and other large volume data.

7.4

GUI

The Graphical User Interface (GUI) is the man-machine interface provided to the user. GUI applications are web based (HTML and Java applets) and run in a standard web browser. Two general types exist:

- Workflow oriented wizards, for example for node expansion and initial configurations.
- Panels used for example to set preferences.

Prepared (also subject responsible if other) EAB/RWB/ZG Christina Wilson	No	18/1551-HRB 105 102/1 Uen		
Approved EAB/RWB/Z (Dennis Radenholt)	Checked	Date 2003-06-16	Rev B	Reference

7.5 Visual and Mechanical Interface

The visual and mechanical interface consists of:

- Optical indicators
- Switches and buttons
- Incoming external power
- External alarms/outputs
- Connectors, cables and screws

8 Operation & Maintenance

This section describes different tasks included in O&M of the RBS.

8.1 Standard Operation

The RBS is configured to suit the requirements of the operator. Configuration Operating Instructions give information regarding different configurations.

The RBS is monitored by means of the RBS Element Manager (EM). The EM is accessed by connecting a thin client to the Site LAN connection plate. Instructions on how to configure and connect a thin client to the RBS is found in *PRODUCT HANDLING*.

For a detailed description of the EM, please refer to *ELEMENT MANAGER*. The following are tasks performed via the EM:

- RBS EM topology view handling
- Configuration management
- Software management
- Alarm management
- Restart
- Timing Unit (TU) switching
- Object properties handling
- Locking and unlocking of objects
- Online help

Prepared (also subject responsible if other) EAB/RWB/ZG Christina Wilson	No 18/1551-HRB 105 102/1 Uen		
Approved EAB/RWB/Z (Dennis Radenholt)	Checked Date 2003-06-16	Rev B	Reference

8.2 Alarms

The RBS alarms are collected in an alarm list. From this list it is possible to:

- Display alarm details
- Acknowledge alarms
- Add comments to alarms

8.2.1 External Alarms

The RBS provides external alarm input ports to be used for both Ericsson and customer specific use. The Ericsson external alarms have a predefined alarm definition while the alarm definition for the customer external alarms can be specified by a command. It is possible to configure whether an alarm is generated by closed or open loop condition.

There are four predefined external alarms in RBS 3104.

- Door Open
- Active Cooler Fault
- External Fan Fault
- Internal Fan Fault