

Prepared (also subject responsible if other) ERA/RGN/PD Jennie Bergström		No 5/1551-HRB 105 102/1 Uen	
Approved ERA/RKF/TU Carl Helander	Checked	Date 2003-01-28	Rev C
		Reference	

Node Description

Contents		Page
1	Introduction	2
1.1	Purpose	2
1.2	Scope	2
2	Radio Network Overview	2
3	RBS Overview	4
3.1	Main Functions	4
3.2	Hardware	5
3.3	Software	5
3.4	RBS Characteristics and Configurations	5
4	Hardware Structure	6
4.1	Connection Field	7
4.2	CU	8
4.3	BB Subrack	8
4.4	RF Subrack	9
4.5	MCPA Subrack	11
4.6	Transmission Interfaces	11
4.7	Internal Cables	11
5	Node Architecture	13
5.1	Structure	14
5.2	Common Platform	16
6	Functions	17
6.1	Application Functions	17
7	External Interfaces	20
7.1	Iub Interface	21
7.2	Uu Interface	21
7.3	Mub Interface	22
7.4	GUI	23
7.5	VMI	23
8	O&M	24
8.1	Standard Operation	24
8.2	Alarms	25

Prepared (also subject responsible if other) ERA/RGN/PD Jennie Bergström	No 5/1551-HRB 105 102/1 Uen		
Approved ERA/RKF/TU Carl Helander	Checked Date 2003-01-28	Rev C	Reference

1 Introduction

This document describes the indoor Radio Base Station (RBS) 3202 in a Radio Access Network (RAN) that uses Wideband Code Division Multiple Access (WCDMA) technology.

1.1 Purpose

This document is intended as a first level introduction to the RBS for network Operations and Maintenance (O&M) personnel.

1.2 Scope

This document is divided in the following sections:

- Radio Network Overview
- RBS Overview
- Hardware Structure
- Software Structure
- Functions
- External Interfaces
- O&M

2 Radio Network Overview

This section gives an overview of the Radio Network of which the RBS is a part. figure 1 shows the parts of the Radio Network.

Prepared (also subject responsible if other) ERA/RGN/PD Jennie Bergström		No 5/1551-HRB 105 102/1 Uen		
Approved ERA/RKF/TU Carl Helander	Checked	Date 2003-01-28	Rev C	Reference

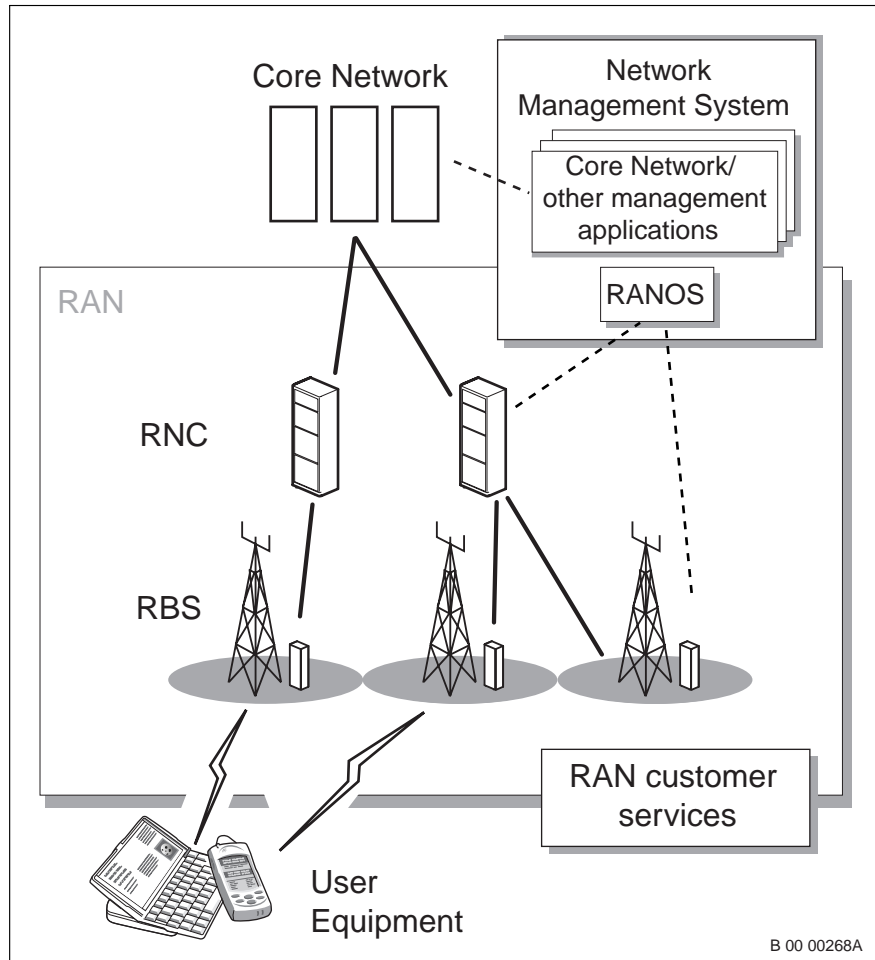

Figure 1 Radio Network Overview

The Radio Network consists of the following parts:

- Core Network

The Core Network (CN) provides call control as well as mobility for, and localization of, the User Equipment (UE). The CN also interacts with the RNC and provides support for network features and telecommunication services. The CN handles both packet-oriented services, such as data, and circuit-oriented services, such as speech.

- RAN

RAN provides the connection between the CN and the User Equipment (UE). RAN also comprises interfaces towards different management systems.

Prepared (also subject responsible if other) ERA/RGN/PD Jennie Bergström	No 5/1551-HRB 105 102/1 Uen		
Approved ERA/RKF/TU Carl Helander	Checked Date 2003-01-28	Rev C	Reference

RAN consists of the following parts:

– RNC

The RNC interacts with the CN as well as the RBSs and manages radio links. The RNC also controls mobility and optimizes the radio network resources.

A single RNC can handle one or more RBSs, and an RNC can work with other RNCs to increase capacity.

For detailed information regarding the RNC, please refer to *Node Description, RNC 3810,6/1551–AXD10503/1*.

– RBS

The RBS's main function is to maintain radio links to UE.

A detailed overview of the RBS 3202 is given in the next section entitled *RBS Overview*.

• RANOS

RANOS is one of the network management systems the operator can use. RANOS handles O&M tasks such as: alarm handling, configuration and performance monitoring.

It is possible to integrate RAN with existing network management systems.

3 RBS Overview

The RBS provides radio resources and handles radio transmission and reception in one or more cells to and from the UE.

3.1 Main Functions

The RBS functionality is divided into traffic and O&M functions.

Traffic related functions include:

- Communicating with the RNC and UE
- Handling cells, transport channels, and ATM links

O&M functions are:

- Ensuring the system becomes, and remains, operational
- Handling equipment malfunction

Prepared (also subject responsible if other) ERA/RGN/PD Jennie Bergström	No 5/1551-HRB 105 102/1 Uen		
Approved ERA/RKF/TU Carl Helander	Checked Date 2003-01-28	Rev C	Reference

- Monitoring the RBS performance

The RBS also contains all the software necessary for Element Management.

3.2 Hardware

The RBS comprises of at least one cabinet with three subracks:

- Baseband (BB)
- Radio Frequency (RF)
- Multiple Carrier Power Amplifier (MCPA)

Apart from the subracks, the RBS consists of a capacitor unit (CU) and a connection field.

3.3 Software

This section gives an overview of the software architecture and common platform. For a detailed description, please refer to page 13.

Software Architecture

The RBS software architecture consists of two layers:

- The common platform layer provides basic support for the application program and includes the operating system and provides support for Asynchronous Transfer Mode (ATM) transport, as well as O&M.
- The application program layer runs on top of the common platform layer and defines the RBS functionality.

A Main Processor (MP) and subordinate Board Processors execute the RBS software.

Common Platform

The RBS software is based on a common platform used both in RBS and RNC. From this platform it is possible to create an ATM cell-switching network node. The common platform consists of an ATM transport system, a distributed real-time telecommunication control system, and an element management system built with Java technology. ATM is used for communication between boards, subracks and nodes.

3.4 RBS Characteristics and Configurations

This section gives an overview of RBS characteristics and configurations.

Prepared (also subject responsible if other) ERA/RGN/PD Jennie Bergström	No 5/1551-HRB 105 102/1 Uen		
Approved ERA/RKF/TU Carl Helander	Checked Date 2003-01-28	Rev C	Reference

3.4.1 Safety and Product Data

The RBS has a CE marking and fulfills requirements for RF, electromagnetic compatibility, and so on.

For detailed information on safety, product data and environmental characteristics, please refer to *HEALTH AND SAFETY INFORMATION* and *PRODUCT DATA*.

3.4.2 Configurations

The RBS has a modular architecture with scalable capacity. A single cabinet can be equipped and configured to handle a minimum of one sector with one carrier, and up to three sectors with two carriers when fully equipped. Currently, the RBS is available in the base configuration 3x2 (three sectors and two carriers) and the subconfigurations 1x2, 2x2, 1x1, 2x1, and 3x1.

For detailed information on different RBS configurations, see *CONFIGURATION DATA*.

4 Hardware Structure

An RBS consists of one or more cabinets, each equipped with three subracks and plug-in-units (PIUs). Which PIUs to use depends on configuration type as well as traffic and transmission capacities.

figure 2 shows the hardware locations.

Prepared (also subject responsible if other) ERA/RGN/PD Jennie Bergström	No 5/1551-HRB 105 102/1 Uen	
Approved ERA/RKF/TU Carl Helander	Checked	Reference
	Date 2003-01-28	Rev C

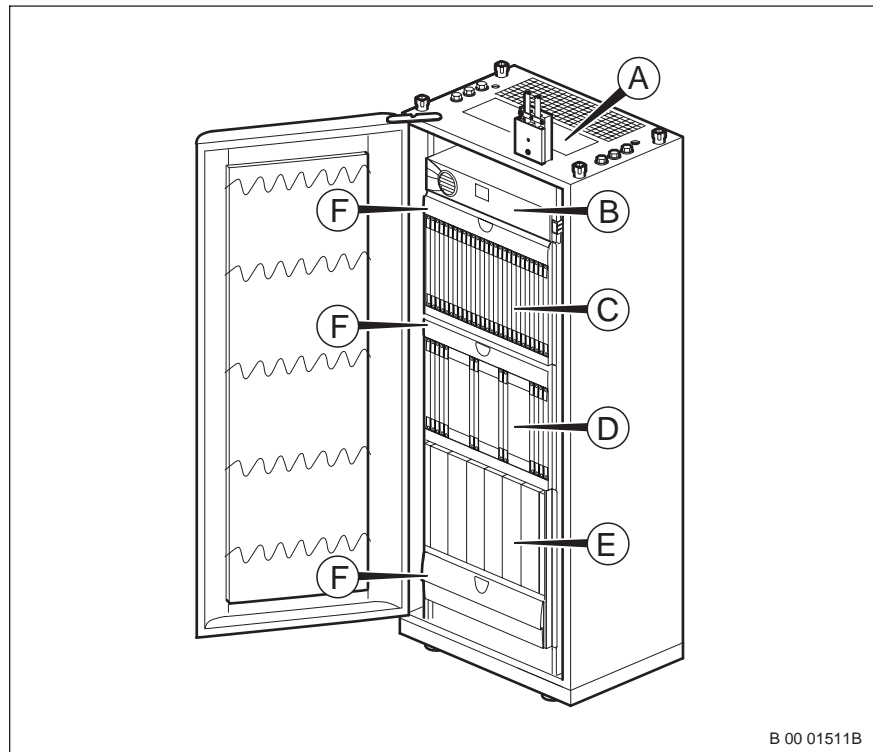

Figure 2 Hardware Locations

The letters in the figure above denote:

- A) Connection Field
- B) CU
- C) BB subrack
- D) RF subrack
- E) MCPA subrack
- F) Subrack Fans

Each subrack houses a number of boards designed for different functions. The boards and units are described later in this chapter

4.1 Connection Field

The Connection Field is located on top of the cabinet and it comprises interfaces for:

- grounding
- local O&M (Site Lan and Element Manager)
- Auxiliary Unit Hub (AU-Hub)

Prepared (also subject responsible if other) ERA/RGN/PD Jennie Bergström	No 5/1551-HRB 105 102/1 Uen		
Approved ERA/RKF/TU Carl Helander	Checked Date 2003-01-28	Rev C	Reference

4.2 CU

The CU keeps the RBS in operation if a short voltage drop should occur on the incoming -48 VDC distribution.

4.3 BB Subrack

Baseband functionality handles dedicated and common channels to UE.

The BB subrack comprises an interface for the connection with an RNC, an MP cluster, the external ATM interface termination as well as all functionality in the baseband domain except for average output power limiter, power clipping, delay- and gain adjustment which all are located in the RF subrack.

The following sections gives a brief description of the boards in the subrack.

4.3.1 ETB

The Exchange Terminal Board (ETB) serves as an interface between the transmission cables and the Asynchronous Transfer Mode (ATM) switch on an Switch Core Board (SCB). The ETB provides the connections for the lub and remote Mub (management interface) interfaces.

The type of ETBs depends on the transmission standard. For more information on the transmission standards, please refer to page 11.

4.3.2 SCB

The SCB contains an ATM switch and is, via the backplane, connected to the ATM switch ports located on other boards. An SCB can also be connected with up to four other SCBs located in other subracks and to the RF subrack for ATM switching parts.

The SCB also has a connector and filter for the system power. The system power is distributed within the subrack via the backplane. The SCB also supervises and controls the subrack fans.

The SCB can be duplicated to provide redundancy. Of one SCB stops working, the other takes over the traffic. The first slot and the last slot the BB and RF subrack are reserved for SCBs.

4.3.3 RAXB

The Random Access/Receiver Board (RAXB) comprises the BB receiver part, which takes care of:

- of decoding, searching and RAKE receiving for dedicated and random access transport channels
- cell combination for softer hand over. A softer hand over takes place when a UE moves from one sector to another using the same frequency.

Prepared (also subject responsible if other) ERA/RGN/PD Jennie Bergström	No 5/1551-HRB 105 102/1 Uen		
Approved ERA/RKF/TU Carl Helander	Checked Date 2003-01-28	Rev C	Reference

RAXBs within a BB subrack share the load to achieve high availability. If one RAXB fails, the load is divided over the remaining RAXBs. This ensures the RBS continues to handle traffic, although with reduced capacity.

4.3.4 GPB

The General Processor Board (GPB) operates as an MP; it contains and executes the main part of the RBS software. The GPB controls devices on boards and in auxiliary units, it has flash disk storage, an Ethernet connection and an RS232 interface.

The GPB can be duplicated to provide redundancy, in case of failure in the active MP, the other GPB can be started and take over as MP.

4.3.5 TXB

The Transmitter Board (TXB) comprises the BB transmitter part for:

- handling transport channels,
- encoding,
- cell splitting,
- modulation and spreading,
- and channel combining.

4.3.6 TUB

The Timing Unit Board (TUB) generates and distributes reference signal for local timing generation. The frequency accuracy is given by an external reference signal either provided on a transmission interface or local external source. The reference signal must be traceable to clock having the equality of Stratum 2 (ITU-T G.812) or better.

The TUB can be duplicated to provide redundancy. Due to close relationship with the SCB, the TUB and SCB must be duplicated simultaneously.

4.3.7 BBIFB

The Baseband Interface Board (BBIFB) connects the BB subrack to the RF subrack. The connection carries the downlink and uplink traffic streams as well as timing signals.

4.4 RF Subrack

The RF subrack contains most of the RF processing hardware (it does not contain the power amplifiers and optional ASC (Antenna System Control)).

The RF subrack takes care of:

Prepared (also subject responsible if other) ERA/RGN/PD Jennie Bergström	No 5/1551-HRB 105 102/1 Uen		
Approved ERA/RKF/TU Carl Helander	Checked Date 2003-01-28	Rev C	Reference

- D/A and A/D conversion
- RF modulation and demodulation
- RF carrier combining and splitting
- Low noise amplification for reception

The following sections give a brief description of the boards in the RF subrack.

4.4.1 SCB

SCB is described at page 8 .

4.4.2 AIU

The Antenna Interface Unit (AIU) board consists of a filter and control unit, as well as a combiner and splitter unit.

Filter and Control Unit

The filter and control unit provide the following:

- Duplex filtering of the transmitter and receiver signal
- Low-noise amplification of the receiver signal
- Power measurement of transmitter signal
- Flexible frequency and signal splitting

Combiner and Splitter Unit

The combiner and splitter unit performs:

- frequency combination in the downlink,
- signal splitting and high power combination when two MCPA modules are used

Frequency combination can be either two- or four-way (when three frequencies have to be combined, the fourth input is unused). When using two MCPA modules for amplification, the combined signal is split, and after amplification, the signals are coherently combined again and sent to one antenna.

4.4.3 RFIFB

The Radio Frequency Interface Board (RFIFB) connects the RF subrack to the BB subrack. The connection carries the downlink and uplink traffic, as well as timing signals. The RFIFB also implements power clipping for downlink traffic.

4.4.4 TRXB

The Transceiver Board (TRXB) provides the following:

Prepared (also subject responsible if other) ERA/RGN/PD Jennie Bergström	No 5/1551-HRB 105 102/1 Uen		
Approved ERA/RKF/TU Carl Helander	Checked Date 2003-01-28	Rev C	Reference

- channel filtering
- delay and gain adjustment
- A/D and D/A conversion
- RF modulation and demodulation

A TRXB comprises two independent transceivers for two transmitter and receiver signal pairs.

4.5 MCPA Subrack

The MCPA subrack contains the linear power amplifiers for the RF carriers.

The subrack contains positions for up to six MCPA modules and is connected to the RF subrack through front panel cabling.

4.5.1 MCPA

The MCPA is a 20 W RF power amplifier.

4.5.2 MCPA Hub

The MCPA Hub is the connection interface between the MCPA and the RFIFB.

4.6 Transmission Interfaces

The cabinet can be equipped and configured for various transmission network needs from one to 32 E1/J1 interfaces and/or one to four STM-1 interfaces.

The Interfaces are as follows:

- E1 — 2 Mbit/s, Transmission Link (European standard)
- J1 — 1.5 Mbit/s, Transmission Link (Japanese standard)
- STM-1 — 155 Mbit/s, Synchronous Transfer Mode on level 1

4.7 Internal Cables

This section gives a brief description of the internal RBS cables.

4.7.1 Inter-Subrack Link

This cable is a common platform ATM interface cable for inter-subrack communication. It carries control signaling from the MP to device boards in other subracks. This interface cable is a high-speed point-to-point communication link.

Prepared (also subject responsible if other) ERA/RGN/PD Jennie Bergström	No 5/1551-HRB 105 102/1 Uen		
Approved ERA/RKF/TU Carl Helander	Checked Date 2003-01-28	Rev C	Reference

4.7.2 **Gamma Cable**

This cable connects the BBIFB and RFIFB. The cable carries serial traffic streams from the gamma interface. The BBIFB and RFIFB can connect two gamma cables, one for each antenna branch.

4.7.3 **Intra-Cabinet Timing Cable**

This cable is also a connection between the BBIFB and RFIFB. This cable connection distributes timing signals from the RF to the BB subrack and is used to read RFIFB product information.

4.7.4 **Inter-Subrack Timing Cable**

This cable distributes timing signals from the TUB to RF subracks. This cable is connected to the BBIFB in the main BB subrack and to all RFIFBs. In a multi-cabinet configuration these cables must have the same length.

4.7.5 **Internal Jumper Cable**

This cable carries the transmit and receive RF signals.

The cable connects an AIU to the Connection Field, and since an AIU can handle two antenna branches, two cables are connected per AIU. For Antenna Near Products, the AIU can feed power through both cable connections. One of the antenna connectors also has the capability to carry the AU interface, which supervises and controls units, for example the ASC.

4.7.6 **MCPA and MCPA Fan Unit Control Cable**

This cable is the AU control connection for the MCPA and MCPA fan unit. This cable is connected between RFIFB and MCPA hub. MCPAs within the MCPA subrack and the fan unit are controlled through the same connection.

4.7.7 **Low-Power Multi-Carrier TX Cable**

This cable carries the low power RF signal after carrier combination and signal splitting (if applicable) from the AIU to the MCPA.

4.7.8 **High-Power TX Cable**

This cable carries the RF signal from the MCPA to the AIU after power amplification.

4.7.9 **Site LAN Cable**

This cable is an Ethernet-based connection for the thin client. The site LAN cable connects the Ethernet interface of the GPB to the Connection Field.

4.7.10 **Transmission Cable**

This cable connects the ETB to the Connection Field.

Prepared (also subject responsible if other) ERA/RGN/PD Jennie Bergström	No 5/1551-HRB 105 102/1 Uen		
Approved ERA/RKF/TU Carl Helander	Checked Date 2003-01-28	Rev C	Reference

4.7.11 CU Control Cable

This cable is an AU interface connection for supervising and controlling the CU. This cable connects the SCB to the capacitor unit via the Connection Field.

4.7.12 XALM Interface Cable

This cable connects the SCB to the Connection Field. The cable is an AU interface and it handles the customer specific alarms and output controls, as well as alarms for Ericsson external equipment.

4.7.13 High-Power Combining Cable

This cable is for combining two MCPAs. The high power combiner in the AIU combines the signal from two MCPAs and sends it to one antenna.

4.7.14 Low-Power Single Carrier TX Cable

This cable connects the TX output of the TRXB to the AIU for carrier combination and signal splitting, if applicable.

4.7.15 BB Subrack Fan Unit Cable

This cable connects the BB subrack fan unit to the SCB and it supervises and controls the fan.

4.7.16 RF Subrack Fan Unit Cable

This cable connects the RF subrack fan unit to the SCB and it supervises and controls the fan.

5 Node Architecture

The general RBS architecture is described in figure 3 and the following subchapters.

Prepared (also subject responsible if other) ERA/RGN/PD Jennie Bergström	No 5/1551-HRB 105 102/1 Uen		
Approved ERA/RKF/TU Carl Helander	Checked Date 2003-01-28	Rev C	Reference

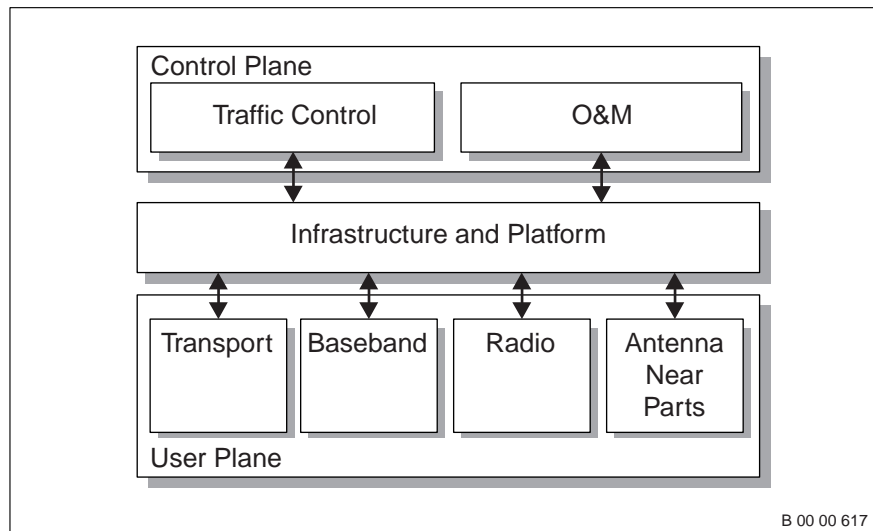

Figure 3 Architectural Overview

Basically, the functionality is divided into two main parts:

- Control plane functionality — for traffic and O&M.
- User plane functionality — for transport, baseband, radio and antenna near parts

As a basis, there are infrastructure and platform functionality that make all parts fit together.

5.1 Structure

There are three important views of an RBS node, each showing a specific aspect and containing several layers:

- Platform View
 - Common Platform Layer
 - Application Program Layer
- Traffic control view
 - Traffic Service Layer
 - Logical Resource Layer
 - Equipment Layer
 - Hardware Layer

Prepared (also subject responsible if other) ERA/RGN/PD Jennie Bergström	No 5/1551-HRB 105 102/1 Uen		
Approved ERA/RKF/TU Carl Helander	Checked Date 2003-01-28	Rev C	Reference

- Management view
 - Presentation Layer
 - Management Adaptation Layer
 - Resource Layer

Platform View

The platform view consists of two layers: the common platform layer and the application program layer.

The application program layer is the software executing on top of the common platform.

The common platform layer isolates the application program layer from the implementation details of the processor and ATM platforms. This makes it possible to change the processor and ATM parts without having to modify the application program. The common platform layer also supports the Element Manager (EM) by providing common platform support functions such as a graphical interface and Java applet communication.

Traffic Control View

This view hides the specific RBS hardware from the actual services supplied by the RBS to the RNC, and other RBS internal functions. This is done to encapsulate the parts of the system that have to be modified when the hardware is modified. Modification includes both modernization of a specific RBS and handling of different types of RBSs.

There are four layers in the traffic control view:

- Traffic service layer — receives service requests from the RNC and then carries out the application program procedures using logical resources (channels, cell-carrier, ATM links, and so on).
- Logical resource layer — provides logical resources to the traffic service layer. It transforms operations on logical resources into operations on devices or ATM entities.
- Equipment layer — hides information as to which specific board a certain functionality is allocated. The functionality is supplied to the Logical Resource Layer in term of devices.
- Hardware layer — hides the detailed design of a hardware item.

Management View

The management view hides implementation details from being visible in the Graphical User Interface (GUI).

There are three layers in the management view:

Prepared (also subject responsible if other) ERA/RGN/PD Jennie Bergström	No 5/1551-HRB 105 102/1 Uen		
Approved ERA/RKF/TU Carl Helander	Checked Date 2003-01-28	Rev C	Reference

- Presentation layer — holds the GUI, which consists of, for example, HTML pages and Java applets. This includes work-flow oriented forms for configuration of the system, support for reading and presenting the event log, and so on. The presentation layer is implemented through web pages and applets which run in a web browser on a PC or Unix workstation.
- Management adaptation layer — isolates the managed objects (MOs) interface from the resource objects. The MOs contain read/write attributes, and methods for operations on these objects. A MO may represent an alarm/event generating object (for example, a plug-in-unit), and also alarm/event handling objects such as logs and notification subscription objects.
- Resource layer — hides the lower level implementation details of the MOs, which reduces the impact of changes. The Resource Layer embraces the Traffic Service Layer, Logical Resource Layer, Equipment Layer and the Hardware Layer.

Fault detection functions in the resource layer, and also in the common platform, ensure fault and error detection. The hardware layer within the resource layer provides fault and error detection support on a low level. The management adaptation layer and the common platform generate the corresponding alarms. Events can have their origin in any part of the system, but the management adaptation layer and the common platform generate the event reports.

5.2 Common Platform

The RNCs and RBSs are based on a Common Platform which consists of modules including both software (such as programs that set up connections and modify operating parameters) and hardware (such as processor boards, switch boards, backplane connectors).

The Common Platform provides the following services to its application programs:

Core

- Software execution platform
- Node O&M
- Java execution platform
- System upgrade during operation
- IP-routing for management
- Space switching of cells over multiple subbracks within the node
- Database
- Loading of MP/BP, fundamental configuration and start/restart functions

Prepared (also subject responsible if other) ERA/RGN/PD Jennie Bergström	No 5/1551-HRB 105 102/1 Uen		
Approved ERA/RKF/TU Carl Helander	Checked Date 2003-01-28	Rev C	Reference

Network and connection handling

- Transport Service
- Signaling Service
- Fractional ATM
- Network Synchronization

6 Functions

The functions are divided into application and common platform functions. The application functions use common platform functions to realize their tasks.

Measurement functionality is divided into a detector part (normally in radio transport functions), and a control part, that controls the measurement. Measurement functions have different roles in the measurement functionality.

The O&M for traffic control functions is included within the function itself. Security aspects are handled within each function that interfaces with the Mub. Security support is provided by the platform functions.

Functions that have an interface for management only cover functionality towards an Mub user. The Mub user can be either an element management node or RANOS.

6.1 Application Functions

The application functions are divided into function groups each covering some specific RBS functionality.

Prepared (also subject responsible if other) ERA/RGN/PD Jennie Bergström	No 5/1551-HRB 105 102/1 Uen		
Approved ERA/RKF/TU Carl Helander	Checked	Date 2003-01-28	Rev C Reference

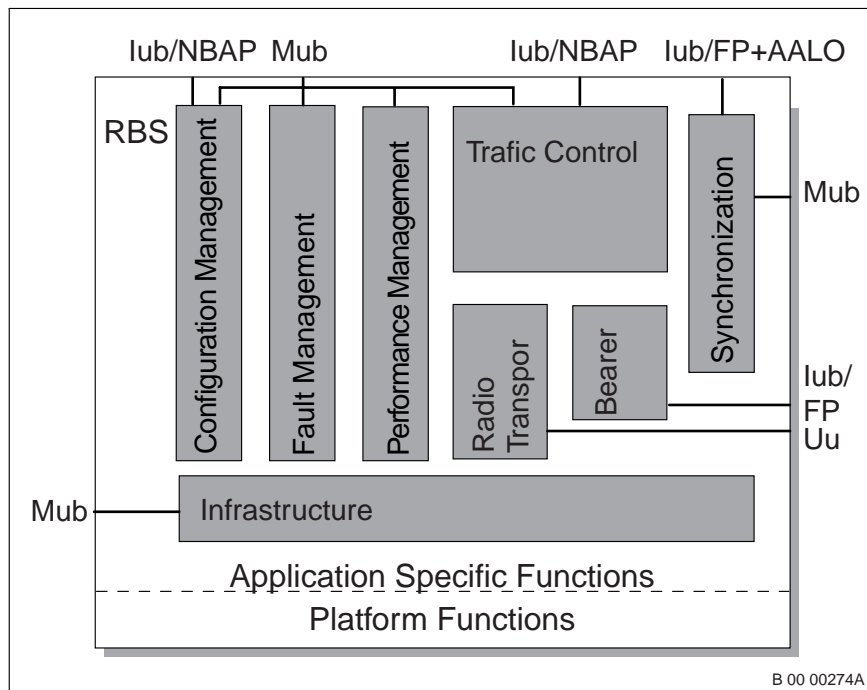

Figure 4 Main RBS Application Function Groups

See table 1 for RBS function groups. The interfaces mentioned in the table text are described in page 20.

Table 1 RBS Function Groups

Function Groups	Task
Fault Management	<p>These functions detect, isolate, and recover from faults in supervised functions.</p> <p>Faults are reported through alarms, and are logged and maintained in an active alarm list.</p> <p>Alarm handling is performed through the Mub interface. Supervision functions are always active and do not have to be configured.</p>

Prepared (also subject responsible if other) ERA/RGN/PD Jennie Bergström		No 5/1551-HRB 105 102/1 Uen
Approved ERA/RKF/TU Carl Helander	Checked	Date 2003-01-28
		Rev C
		Reference

Function Groups	Task
Configuration Management	<p>These functions create and delete MOs.</p> <p>Attributes of these MOs can be set and read.</p> <p>These functions are performed over the Mub interface. Some functions use the lub interface.</p>
Performance Management	<p>These functions collect, store and report statistics regarding RBS measurements.</p> <p>These functions are performed through the Mub interface.</p>
Traffic Control	<p>These functions provide control of traffic-related resources such as common and dedicated radio connections, cells and ATM connections. The functions also provide measurement control requested from the RNC.</p> <p>Traffic control is performed through the lub interface and is managed over the Mub interface.</p>
Radio Transport	<p>These functions manage user data processing in the BB and RF parts of the RBS node.</p> <p>The functions handle the air interface Uu.</p> <p>Measurement detector functionality is also included.</p>
Bearer	<p>These functions transfer user or control data between the RNC and RBS.</p> <p>The data is carried over the lub interface.</p>

Prepared (also subject responsible if other) ERA/RGN/PD Jennie Bergström		No 5/1551-HRB 105 102/1 Uen	
Approved ERA/RKF/TU Carl Helander	Checked	Date 2003-01-28	Rev C Reference

Function Groups	Task
Synchronization	<p>These functions provide correct data timing, and prevent data loss due to slip of sent and received information through the system. The functions also provide stable frequency references for RF stabilization.</p> <p>These functions are managed through the Mub interface. Synchronization frames are carried over the lub interface to and from RNC.</p>
Infrastructure	<p>These functions handle power feeding, environmental control and basic infrastructure software functionality.</p> <p>These functions are managed through the Mub interface.</p>
GUI	<p>This function group contains the GUI functionality.</p> <p>The user interface handles the GUI.</p>

7 External Interfaces

The RBS is connected to the outside world through the lub, Uu and Mub interfaces. Besides these interfaces, the RBS provides a management GUI that uses the Mub, as well as a Visual and Mechanical Interface (VMI). The VMI comprises indicators, switches, buttons, cables, and so on. An overview of the external interfaces is given in figure 5.

Prepared (also subject responsible if other) ERA/RGN/PD Jennie Bergström	No 5/1551-HRB 105 102/1 Uen
Approved ERA/RKF/TU Carl Helander	Checked Date 2003-01-28
	Rev C
	Reference

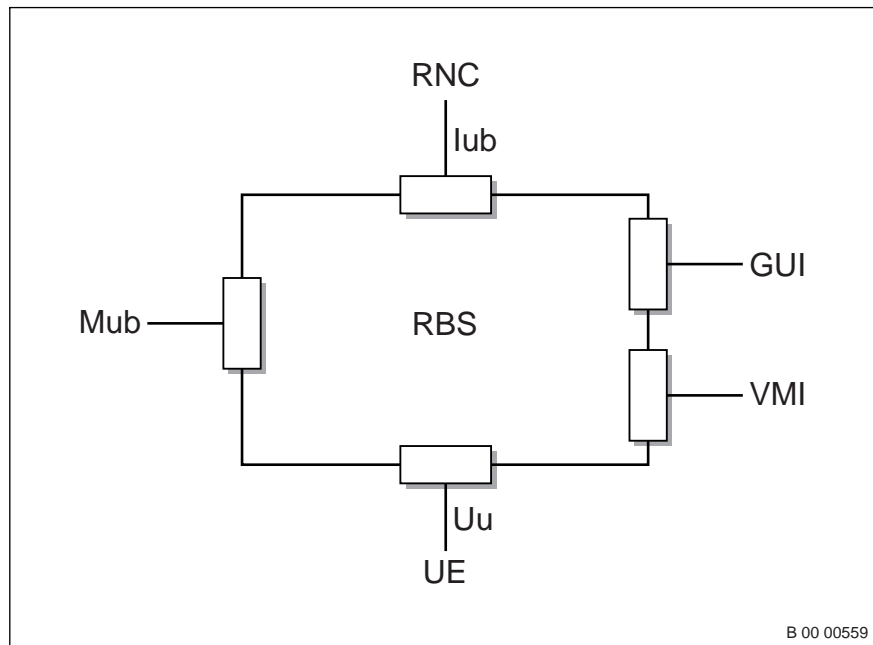

Figure 5 External Interfaces

7.1 Iub Interface

The Iub interface is the standardized interface between the RBS and the RNC. The Iub is divided into several protocol layers:

- Physical layer (L1)
- ATM and ATM adaptation layers (L2)
- Network layer (L3) for frame handling

The L3 protocol for the RNC plane is called NBAP. The L2 and L3 part of air interface channels RACH, FACH, PCH and DCH terminate in the RNC. From an RBS perspective, the different air interface channels are all treated as transparent user plane channels.

7.2 Uu Interface

The Uu interface is the radio interface between RBS and the UE. The radio interface is divided into three protocol layers:

- Physical layer (L1)
- Data link layer (L2)
- Network layer (L3)

Prepared (also subject responsible if other) ERA/RGN/PD Jennie Bergström		No 5/1551-HRB 105 102/1 Uen	
Approved ERA/RKF/TU Carl Helander	Checked	Date 2003-01-28	Rev C Reference

The L2 comprises of Medium Access (MAC) and Radio Link Control (RLC). The MAC provides unacknowledged transfer of SDUs between peer MAC entities, and the RLC provides data transfer of SDU and can also support the retransmission protocol. L3 comprise the Radio Resource Control (RRC), which interfaces with L2.

7.3 Mub Interface

The Mub is the management interface for the RBS and, in contrast to the lub, is not standardized. The user interacts with the system using a web based thin client. The thin client gets software that is dependent on the managed RBS by loading Java applets from the RBS at execution time.

The Mub is based on IP, so the RBS has an IP address. Remote management uses IP over ATM and on-site management uses Ethernet. The necessary low-level communication layers, including FTP server, HTTP server, ORB and Telnet server, are provided by the common platform.

The management interfaces are shown in figure 6.

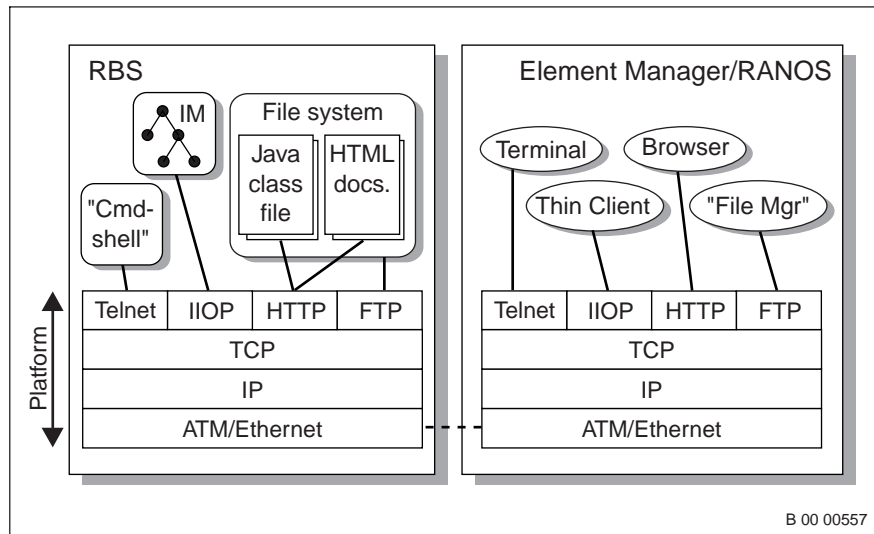

Figure 6 Management Interfaces

The interfaces are used as follows:

- Telnet

Telnet provides local and remote access to the operating system shell. The command line interface provides a set of commands handled by a Unix shell-like command interpreter.
- IIOP

Prepared (also subject responsible if other) ERA/RGN/PD Jennie Bergström	No 5/1551-HRB 105 102/1 Uen		
Approved ERA/RKF/TU Carl Helander	Checked Date 2003-01-28	Rev C	Reference

IIOIP (IP based Inter-ORB Protocol) is the protocol used in Common Object Request Broker Architecture (CORBA). IIOIP is the main protocol used for O&M; both the EM and the network manager (RANOS) uses IIOIP.

- HTTP

HTTP transfers HTML documents such as online documentation and Java applets from the file system to a managing system.

- FTP

FTP transfers files to and from the file system in the RBS. FTP is primarily used for loading software, configuration data and other large volume data.

7.4 GUI

GUI applications are web based (HTML and Java applets) and run in a standard web browser. Two general types exist:

- Workflow oriented wizards, for example, for node expansion, initial configurations, and so on
- Panels used to set preferences, options, and so on

7.5 VMI

The VMI consists of:

- Visual indicators
- Switches and buttons
- Incoming external power
- External alarms and output
- Connectors, cables and screws

Visual Indicators

Each unit or board in the RBS is equipped with Light Emitting Diodes (LEDs): red ones for fault indication and green ones for indication of operation. Additionally, boards with a processor are equipped with a yellow LED for traffic indication. All LEDs light simultaneously for one second when the power is switched on.

Switches and buttons

- Each power output connector in the busbar is equipped with fused circuit breakers.

Prepared (also subject responsible if other) ERA/RGN/PD Jennie Bergström	No 5/1551-HRB 105 102/1 Uen		
Approved ERA/RKF/TU Carl Helander	Checked Date 2003-01-28	Rev C	Reference

- The AIU board has RF jumpers/cables to be able to allow for different RBS configurations with the same board. The jumpers connects combiners and splitters that are applicable for a certain configuration.
- The PCU contains a number of switches for the power system.
- The GPB and all device boards are equipped with a reset button. (The button is not reachable from the front of the board).

Incoming External Power

The RBS can be fed by either AC, DC +24V or DC -48V depending on the power equipment.

External Alarms and Output

The RBS supports external alarm input ports for both Ericsson or customer-specific use. The operator can configure whether an if an alarm generated by closed or open loop condition. Closed loop means that an alarm is triggered when an open switch is closed, and open loop condition means that an alarm is triggered when a closed switch is open. A number of external output ports for control of external equipment are also available in the RBS. The ports are controlled from a management interface.

Connectors, cables and screws

This is the actual mechanical interface for the RBS. The interface specifies the mounting of boards into subracks, and how to mount subracks in cabinets.

8 O&M

O&M is handled through embedded management. It deals with issues such as: configuration, fault, performance, and security management.

8.1 Standard Operation

The EM monitors the RBS. The user accesses the EM by connecting a thin client to the Site LAN connection plate. Instructions on how to configure and connect a thin client to the RBS are found in *PRODUCT HANDLING*.

For a detailed description of the EM, please refer to *ELEMENT MANAGER*.

The EM performs the following tasks:

- RBS EM topology view handling
- Configuration management
- Software management
- Alarm management

Prepared (also subject responsible if other) ERA/RGN/PD Jennie Bergström	No 5/1551-HRB 105 102/1 Uen		
Approved ERA/RKF/TU Carl Helander	Checked Date 2003-01-28	Rev C	Reference

- Restart
- Timing Unit (TU) switch
- Object properties handling
- Locking and unlocking of objects
- Online help

8.2 Alarms

The RBS alarms are collected in an alarm list. From this list it is possible to:

- Display alarm details
- Acknowledge alarms
- Add comments to an alarm