

Prepared (also subject responsible if other)		No.		
EAB/RWG/RB Larry Lindström		B5KAKRB1011112-2		
Approved	Checked	Date	Rev	Reference
KI/EAB/RWG/RB (L Lindström)		2003-12-23	A	

1 EXHIBIT 4 – BLOCK DIAGRAMS AIU

Contents

1	EXHIBIT 4 – BLOCK DIAGRAMS AIU	1
1.1	Block Diagram MCPA and AIU	2
1.2	AIU CSU WCDMA 1911-ROA 128 0767/1 RF Low Power Block	3
1.3	AIU FCU WCDMA 1911-ROA 128 0230/1 RF Power Block	4

Clarification

Antenna Branch B on page 2 is not in use.

Prepared (also subject responsible if other)		No.		
EAB/RWG/RB Larry Lindström		B5KAKRB101112-2		
Approved	Checked	Date	Rev	Reference
KI/EAB/RWG/RB (L Lindström)		2003-12-23	A	

1.1 Block Diagram MCPA and AIU

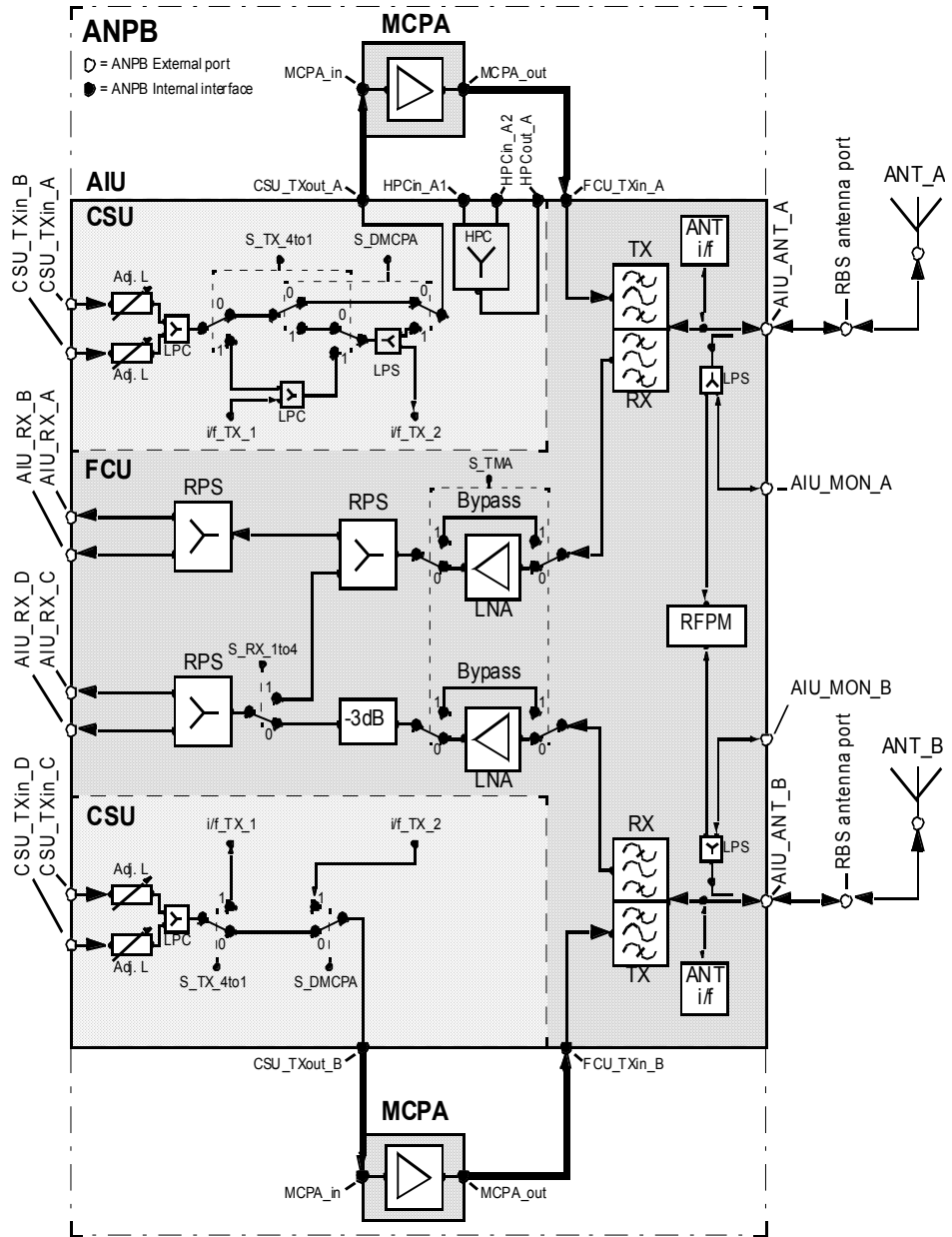

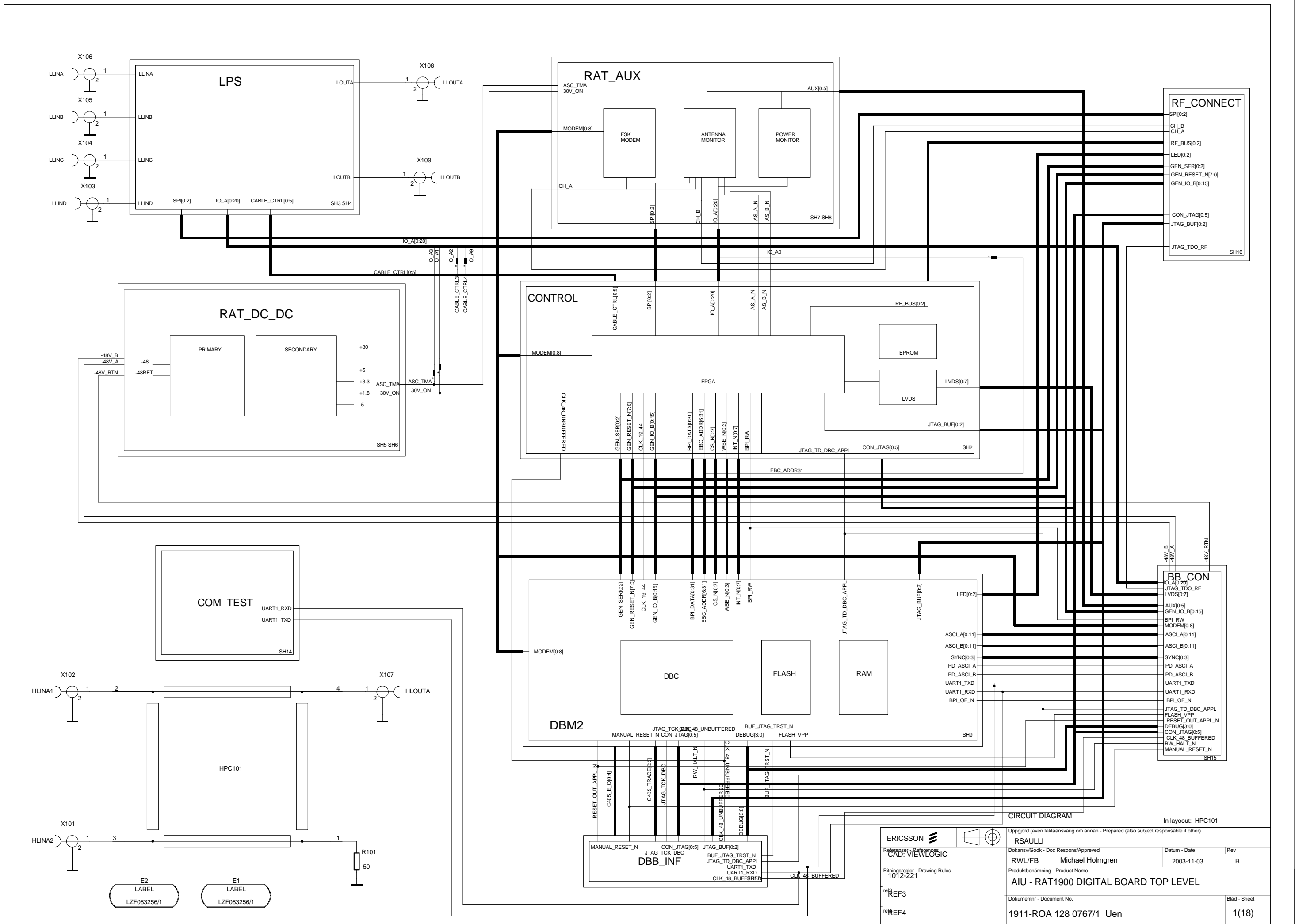

CIRCUIT DIAGRAM

In layout: HPC101

Uppgjord (även faktaansvarig om annan - Prepared (also subject responsible if other)		Datum - Date		Rev	
RSALLI		2003-11-03		B	
Dokansv/Goak - Doc Respons/Approved		RWL/FB Michael Holmgren		Produktbenämning - Product Name	
1012-221		1911-ROA 128 0767/1 Uen		AIU - RAT1900 DIGITAL BOARD TOP LEVEL	
Ritningsregler - Drawing Rules		Dokumentnr - Document No.		Blad - Sheet	
REF3		1911-ROA 128 0767/1 Uen		1(18)	
REF4					

ERICSSON

CAD: VIEWLOGIC

1012-221

REF3

REF4

E2 LABEL LZF083256/1

E1 LABEL LZF083256/1

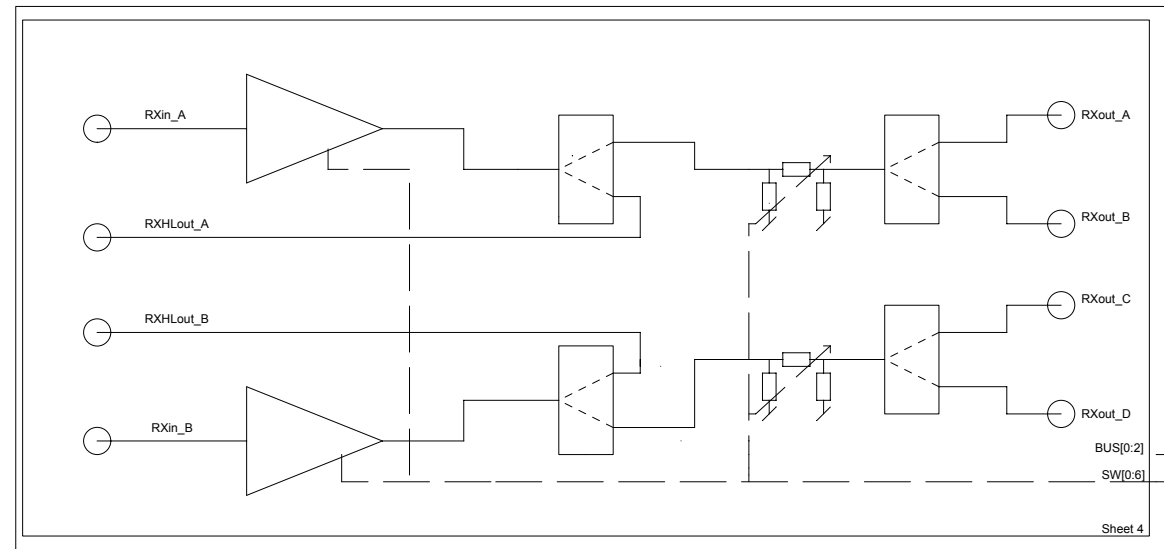

RXPATH

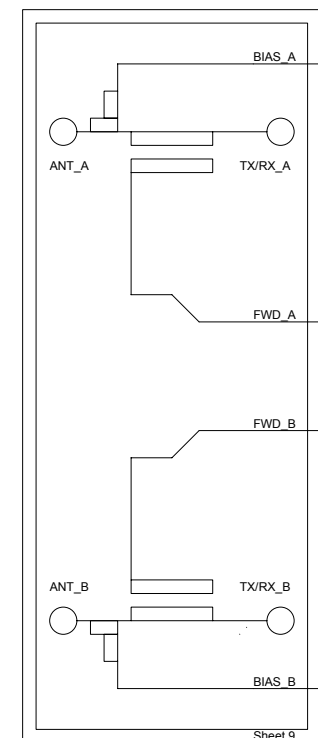

MCU

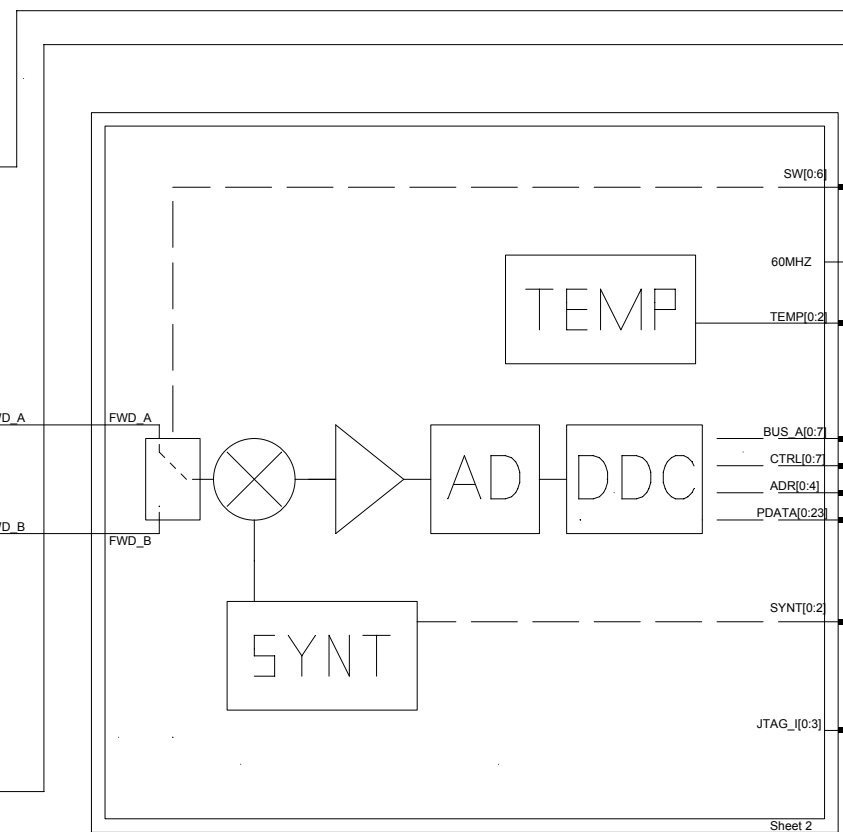

RFPM

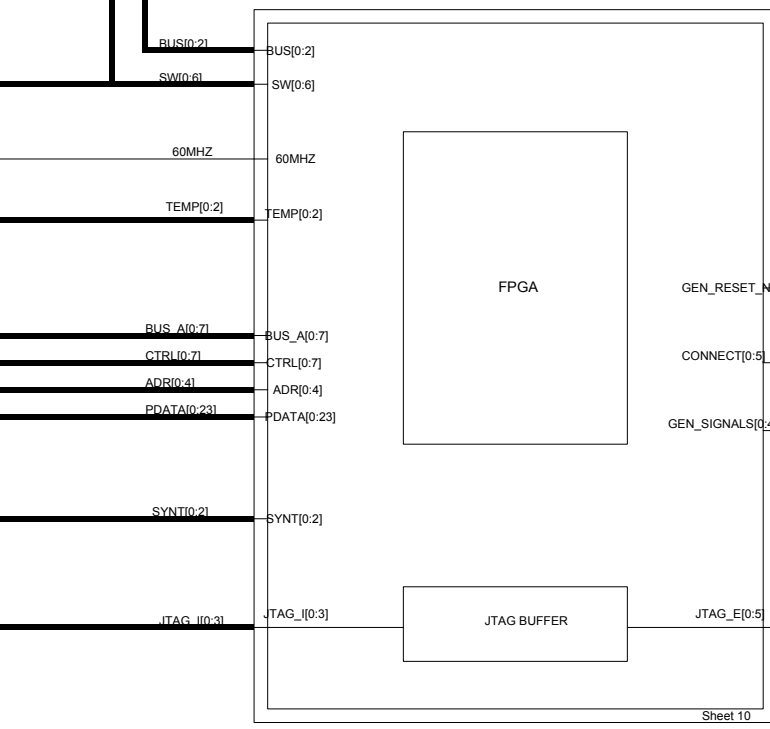

CONTROL

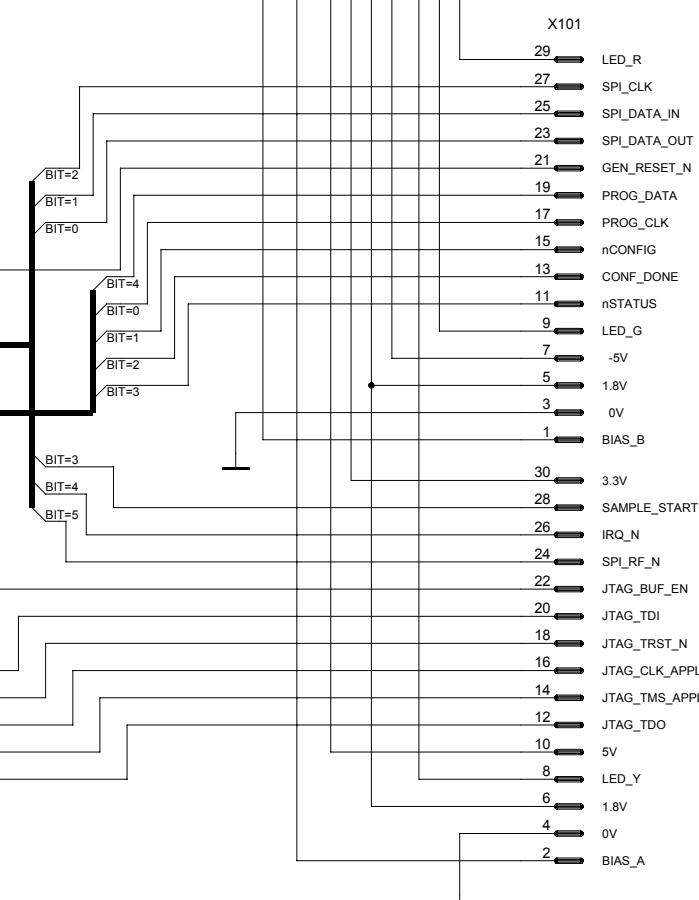
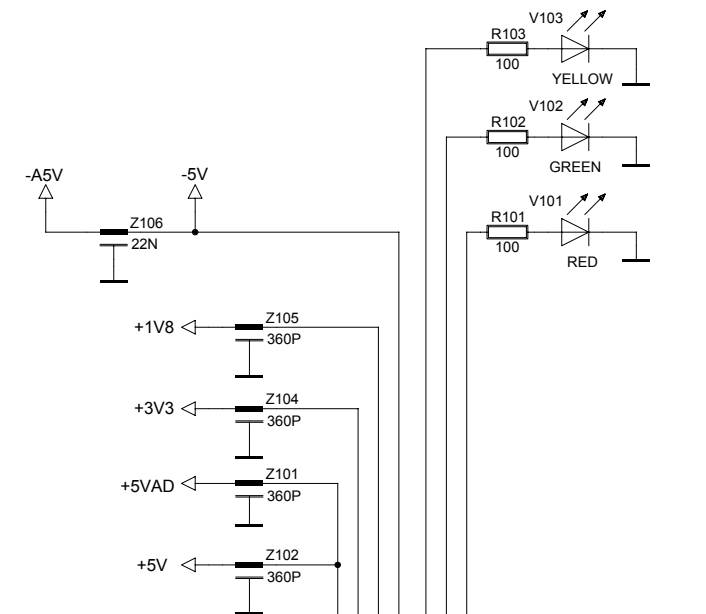

E1 LABEL LZF38314/4L

ERICSSON				CIRCUIT DIAGRAM	
Referenser - References				Uppgjord (även faktaansvarig om annan - Prepared (also subject responsible if other)	
CAD: VIEWLOGIC		RSALENK, RSAAWI		RSAAWI, RSALENK	
Ritningsregler - Drawing Rules		Dokansv/Godk - Doc Respons/Approved		Datum - Date	
1012-221		EAB/RWL/RR (LARS BROTAEUS)		2003-09-29	
ref3 REF3		Produktbenämning - Product Name		Blad - Sheet	
ref4 REF4		AIU-1900 RF BOARD		1 (10)	
1911- ROA 128 0230/1				Blad - Sheet	