

FCC IC Test Report Part 74 & RSS-210

Report No.: FCC_IC_RF_SL19101602-BSS-009_BTR-80N Rev_1.0

Product: Narrowband UHF Wireless Intercom Base Station

Models: BTR-80N-FD, BTR-80N-FE, BTR-80N-HE

FCC ID: B5DM544

IC: 1321A-BTR80NDE

Received Date: 12/09/2019

Test Date: 01/02/2020-01/19/2020

Issued Date: 02/25/2020

Applicant: Bosch Security Systems, Inc.

Applicant Address: 8601 East Cornhusker Highway, Lincoln, NE 68507 USA

Manufacturer: Bosch Security Systems, Inc.

Manufacturer Address: 130 Perinton Parkway, Fairport, NY 14450 USA.

Issued By: Bureau Veritas Consumer Products Services, Inc.

Lab Address: 775 Montague Expressway, Milpitas, CA 95035

**FCC Registration /
Designation Number:** 540430

ISED# / CAB identifier: 4842D



This report is for your exclusive use. Any copying or replication of this report to or for any other person or entity, or use of our name or trademark, is permitted only with our prior written permission. This report sets forth our findings solely with respect to the test samples identified herein. The results set forth in this report are not indicative or representative of the quality or characteristics of the lot from which a test sample was taken or any similar or identical product unless specifically and expressly noted. Our report includes all of the tests requested by you and the results thereof based upon the information that you provided to us. You have 60 days from date of issuance of this report to notify us of any material error or omission caused by our negligence, provided, however, that such notice shall be in writing and shall specifically address the issue you wish to raise. A failure to raise such issue within the prescribed time shall constitute your unqualified acceptance of the completeness of this report, the tests conducted and the correctness of the report contents. Unless specific mention, the uncertainty of measurement has been explicitly taken into account to declare the compliance or non-compliance to the specification. The report must not be used by the client to claim product certification, approval, or endorsement by A2LA or any government agencies.

TABLE OF CONTENTS

RELEASE CONTROL RECORD	4
1 CERTIFICATE OF CONFORMITY	5
2 SUMMARY OF TEST RESULTS.....	6
2.1 MEASUREMENT UNCERTAINTY.....	7
3 GENERAL INFORMATION	8
3.1 GENERAL DESCRIPTION OF EUT	8
3.2 DESCRIPTION OF TEST MODES	9
3.2.1 GENERAL DESCRIPTION OF APPLIED STANDARDS.....	10
3.3 DESCRIPTION OF SUPPORT UNITS	10
3.3.1 CONFIGURATION OF SYSTEM UNDER TEST.....	11
4 TEST TYPES AND RESULTS.....	12
4.1 OUTPUT POWER MEASUREMENT.....	12
4.1.1 LIMITS OF OUTPUT POWER MEASUREMENT	12
4.1.2 TEST INSTRUMENTS	12
4.1.3 TEST PROCEDURES.....	12
4.1.4 TEST SETUP	13
4.1.5 EUT OPERATING CONDITIONS	13
4.1.6 TEST RESULTS.....	14
4.2 FREQUENCY STABILITY MEASUREMENT	15
4.2.1 LIMITS OF FREQUENCY STABILITY MEASUREMENT.....	15
4.2.2 TEST INSTRUMENTS	15
4.2.3 TEST PROCEDURE	16
4.2.4 TEST SETUP	16
4.2.5 TEST RESULTS.....	17
4.3 MODULATION DEVIATION MEASUREMENT	19
4.3.1 LIMITS OF MODULATION DEVIATION MEASUREMENT	19
4.3.2 TEST INSTRUMENTS	19
4.3.3 TEST PROCEDURE	20
4.3.4 TEST SETUP	21
4.3.5 TEST RESULTS.....	22
4.4 OCCUPIED BANDWIDTH AND EMISSION MASK MEASUREMENT	26
4.4.1 LIMITS OF OCCUPIED BANDWIDTH AND EMISSION MASK MEASUREMENT	26
4.4.2 TEST INSTRUMENTS	26
4.4.3 TEST SETUP	27
4.4.4 TEST PROCEDURES.....	28
4.4.5 TEST RESULTS.....	29
4.5 CONDUCTED SPURIOUS EMISSIONS	33
4.5.1 LIMITS OF CONDUCTED SPURIOUS EMISSIONS MEASUREMENT.....	33
4.5.2 TEST INSTRUMENTS	33
4.5.3 TEST PROCEDURE	34
4.5.4 TEST SETUP	34
4.5.5 EUT OPERATING CONDITIONS	34
4.5.6 TEST RESULTS.....	35

4.6	RADIATED EMISSION MEASUREMENT	37
4.6.1	LIMITS OF RADIATED EMISSION MEASUREMENT	37
4.6.2	TEST INSTRUMENTS	38
4.6.3	TEST PROCEDURES.....	39
4.6.4	DEVIATION FROM TEST STANDARD.....	39
4.6.5	TEST SETUP.....	40
4.6.6	EUT OPERATING CONDITIONS	40
4.6.7	TEST RESULTS.....	41
7	PHOTOGRAPHS OF THE TEST CONFIGURATION	45
8	INFORMATION OF THE TESTING LABORATORIES	46

Release Control Record

Issue No.	Reason for change	Date issued
FCC_IC_RF_SL19101602-BSS-009_BTR-80N	Original release	02/03/2020
FCC_IC_RF_SL19101602-BSS-009_BTR-80N Rev_1.0	Update Applicant & Manufacturer Address Per Customer Review	02/25/2020

1 Certificate of Conformity

Product: Narrowband UHF Wireless Intercom Base Station
Brand: RTS
Models: BTR-80N-FD, BTR-80N-FE, BTR-80N-HE
Sample Status: Engineering sample
Applicant: Bosch Security Systems, Inc.
Test standards: FCC 47 CFR Part 74
RSS-210 Issue 10 December 2019

The above equipment has been tested by **Bureau Veritas Consumer Products Services, Inc., Milpitas Branch**, and found compliance with the requirement of the above standards. The test record, data evaluation & equipment under test (EUT) configurations represented herein are true and accurate accounts of the measurements of the sample's EMC characteristics under the conditions specified in this report.

Prepared by :  , **Date:** 02/25/2020
Deon Dai / Test Engineer

Approved by :  , **Date:** 02/25/2020
Chen Ge / Engineer Reviewer

2 Summary of test results

The EUT has been tested according to the following specifications:

Applied standard: FCC Part74 & Part 2 RSS-210 Annex G			
Standard section	Test type and limit	Result	Remark
2.1046 74.861 RSS-210 G.1	RF Power Output	Pass	Meet the requirement of limit.
2.1055 74.861 RSS-210 G.3	Frequency Stability	Pass	Meet the requirement of limit.
2.1047 74.861 RSS-210 G.5	Modulation Deviation	Pass	Meet the requirement of limit.
2.1047 RSS-210 G.5	Audio Frequency Response	Pass	Meet the requirement of limit.
2.1049 74.861 RSS-210 G.2	Occupied Bandwidth	Pass	Meet the requirement of limit.
2.1051 74.861 RSS-210 G.4	Conducted Spurious Emissions	Pass	Meet the requirement of limit.
2.1051 74.861 RSS-210 G.4	Radiated Spurious Emissions	Pass	Meet the requirement of limit.

2.1 Measurement uncertainty

Where relevant, the following measurement uncertainty levels have been estimated for tests performed on the EUT:

This uncertainty represents an expanded uncertainty expressed at approximately the 95% confidence level using a coverage factor of $k=2$.

Measurement	Frequency	Expanded Uncertainty ($k=2$) (\pm)
Conducted Emissions at mains ports	150kHz ~ 30MHz	3.51dB
Radiated Emissions up to 1 GHz	30MHz ~ 1GHz	3.73dB
Radiated Emissions above 1 GHz	1GHz ~ 6GHz	4.64dB
	6GHz ~ 18GHz	4.82dB
	18GHz ~ 40GHz	4.91dB

3 General Information

3.1 General Description of EUT

Product	Narrowband UHF Wireless Intercom Base Station
Brand	RTS
Models	BTR-80N-FD, BTR-80N-FE, BTR-80N-HE
FCC ID	B5DM544
IC	1321A-BTR80NDE
Power Supply	100~240 Vac, 1A, 50~60Hz
Modulation	FM
Operating Frequency	BTR-80N Band FD: TX: 482.225-499.975MHz RX:572-590MHz BTR-80N Band HE: TX: 500.225-517.975MHz RX:590-608MHz
Channel Bandwidth	100kHz
Max. Conducted power	BTR-80N Band FD: 21.91 dBm BTR-80N Band HE: 23.42 dBm
Antenna type	Dipole Antenna
Antenna gain	0.5dBi
Associated Devices	N/A

Note:

1. The above EUT information was declared by the manufacturer and for more detailed features description, please refer to the manufacturer's specifications or user's manual.

3.2 Description of test modes

The following channels have been tested and presented.

BTR-80N FD Band		BTR-80N HE Band	
Channel	Frequency (MHz)	Channel	Frequency (MHz)
Low	482.225	Low	500.225
Middle	491.050	Middle	509.050
High	499.975	High	517.975

3.2.1 General Description of Applied Standards

The EUT has RF transmitter and receiver. According to the specifications of the manufacturer, it must comply with the requirements of the following standards:

FCC 47 CFR part 2

FCC 47 CFR part 74

RSS-210 Issue 10 December 2019

ANIS/TIA/EIA-603-e 2016

ANSI 63.26-2015

All test items have been performed and recorded as per the above standards.

3.3 Description of support units

The EUT has been tested as an independent unit together with other necessary accessories or support units. The following support units or accessories were used to form a representative test configuration during the tests.

Note: all power cords of the above support units are Non-shielded (1.8m).

3.3.1 Configuration of system under test

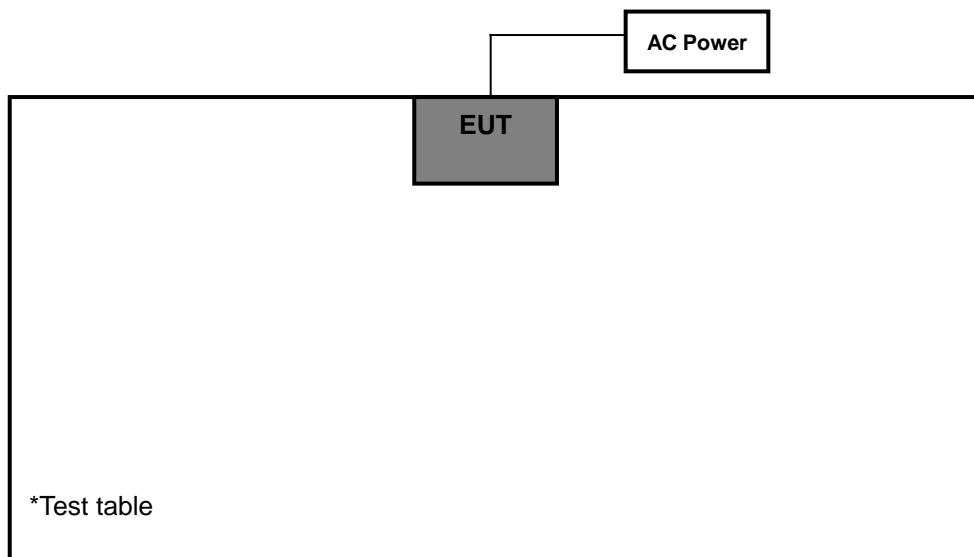

4 Test types and results

4.1 Output Power Measurement

4.1.1 Limits of output power measurement

LPAS operation in TV bands	
Frequency Band	Conducted Output Power
54 – 72MHz 76 – 88MHz 174 – 216MHz	50mW (17dBm) EIRP
470 – 608 614 - 698	250mW (24dBm)

LPAS operation in other than TV bands	
Conducted Power (W)	1

4.1.2 Test instruments

For conducted power:

Description & manufacturer	Model no.	Serial no.	Calibrated date	Calibrated until
USB Power Sensor	7002-006	159814	03/18/2019	03/18/2020
30dB Attenuation	VAT-30W2	N/A	N/A	N/A

4.1.3 Test procedures

The transmitter output was connected to power meter through an attenuator. The test result was measured and recorded.

4.1.4 Test setup

Conducted power measurement:

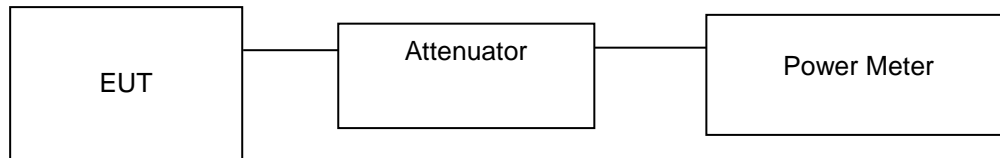

4.1.5 EUT operating conditions

- a. Placed the EUT on the testing table.
- b. Turn on the EUT power by battery.
- c. Enable EUT under transmission condition continuously at specific channel frequency.

4.1.6 Test results

FCC

Band	Frequency (MHz)	Output Power (dBm)	Output Power (mW)	Limit (mW)
BTR-80N FD	482.225	21.73	148.94	250
	491.050	21.91	155.24	250
	499.975	21.76	149.97	250
BTR-80N HE	500.225	23.35	216.27	250
	509.050	22.98	198.61	250
	517.975	23.42	219.79	250

IC

Band	Frequency (MHz)	Output Power (dBm)	Antenna Gain (dBi)	EIRP (mW)	EIRP Limit (mW)
BTR-80N FD	482.225	21.73	0.5	167.11	250
	491.050	21.91	0.5	174.18	250
	499.975	21.76	0.5	168.27	250
BTR-80N HE	500.225	23.35	0.5	242.66	250
	509.050	22.98	0.5	222.84	250
	517.975	23.42	0.5	246.60	250

Note: The antennas are sleeve dipole antennas. By itself, it has a gain of 2 dBi. However they are not matched to 50 Ohms which is the impedance of the TNC jack/coaxial cable. These antennas naturally have a lot higher impedance than 50 Ohms. The dipole antenna over the range 482 – 518 MHz has about a 2.5 to 1 VSWR match. So about 1dB is loss in matching and another 0.5 due to losses at UHF. So effectively the antenna when combined with the device is about a **0.5 dBi** gain antenna.

4.2 Frequency stability measurement

4.2.1 Limits of frequency stability measurement

Frequency stability	Limit
Refer as FCC 74.861 (e)(4) RSS-210 G.3	0.005%

According to the FCC part 2.1055 shall be tested the frequency stability. The test extreme voltage is according to the 2.1055(d)(1) vary primary supply voltage from 85 to 115 percent of the nominal value for other than hand carried battery equipment and the extreme temperature rule is comply with specification of EUT -30°C ~ 50°C.

4.2.2 Test instruments

Description & manufacturer	Model no.	Serial no.	Calibrated date	Calibrated until
50GHz Spectrum Analyzer	N9030B (PXA)	MY57140597	06/05/2019	06/05/2020
Temperature/Humidity Chamber	1007H	61201	12/16/2019	12/16/2020

4.2.3 Test procedure

- a. Turn on EUT and set spectrum analyzer center frequency to the EUT operating frequency. Set spectrum analyzer Resolution Bandwidth to 1 kHz and Video Resolution Bandwidth to 1 kHz AND Frequency Span to 50 kHz, Record this frequency as reference frequency.
- b. Set the temperature of chamber to 50°C. Allow sufficient time (approximately 30 min) for the temperature of the chamber to stabilize. While maintaining a constant temperature inside the chamber. Turn the EUT on and measure the EUT operating frequency.
- c. Repeat set 2 with a 10°C decreased per stage until the lowest temperature -30°C is measured. Record all measured frequencies on each temperature step.
- d. Vary primary supply voltage from 85 to 115 percent of the nominal value for other than hand carried battery equipment.

4.2.4 Test setup

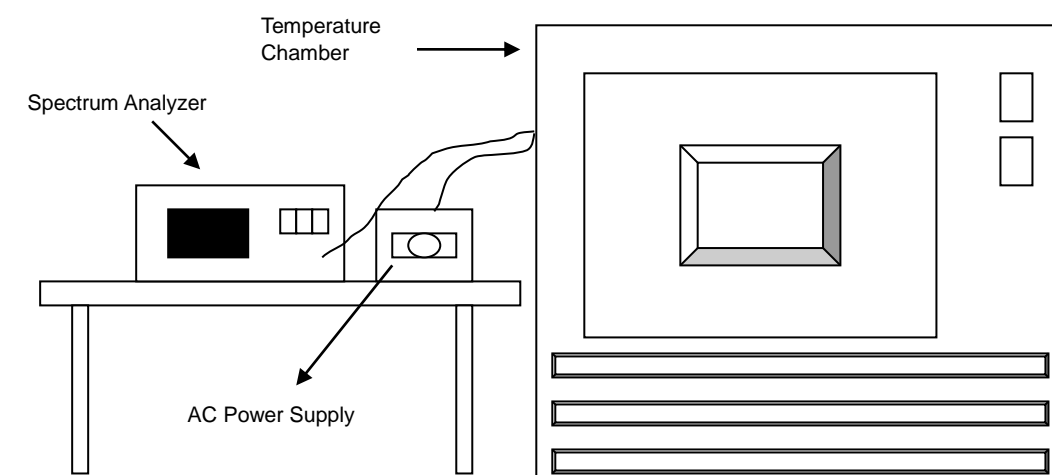

4.2.5 Test results

BTR-80N FD:

Mode	Middle channel 491.05(MHz)	Input power	120Vac, 60Hz
Environmental conditions	20°C, 60%rh	Tested by	Deon Dai

Frequency error vs. Voltage								
Voltage (volts)	0minutes		2minutes		5minutes		10minutes	
	Frequency (MHz)	(%)	Frequency (MHz)	(%)	Frequency (MHz)	(%)	Frequency (MHz)	(%)
138	491.0465	-0.00071	491.0497	-0.00006	491.0484	-0.00033	491.0506	0.00012
120	491.0507	0.00014	491.0490	-0.00020	491.0506	0.00012	491.0484	-0.00033
102	491.0499	-0.00002	491.0507	0.00014	491.0488	-0.00024	491.0494	-0.00012

Frequency error vs. Temp								
Temp (°C)	0minutes		2minutes		5minutes		10minutes	
	Frequency (MHz)	(%)	Frequency (MHz)	(%)	Frequency (MHz)	(%)	Frequency (MHz)	(%)
50	491.0497	-0.00006	491.0506	0.00012	491.0504	0.00008	491.0492	-0.00016
40	491.0492	-0.00016	491.0484	-0.00033	491.0489	-0.00022	491.0502	0.00004
30	491.0505	0.00010	491.0506	0.00012	491.0505	0.00010	491.0486	-0.00029
20	491.0486	-0.00029	491.0492	-0.00016	491.0488	-0.00024	491.0502	0.00004
10	491.0484	-0.00033	491.0489	-0.00022	491.0502	0.00004	491.0482	-0.00037
0	491.0507	0.00014	491.0507	0.00014	491.0488	-0.00024	491.0508	0.00016
-10	491.0502	0.00004	491.0489	-0.00022	491.0504	0.00008	491.0488	-0.00024
-20	491.0497	-0.00006	491.0492	-0.00016	491.0488	-0.00024	491.0505	0.00010
-30	491.0498	-0.00004	491.0489	-0.00022	491.0508	0.00016	491.0502	0.00004

BTR-80N HE:

Mode	Middle channel 509.05(MHz)	Input power	120Vac, 60Hz
Environmental conditions	20°C, 60%rh	Tested by	Deon Dai

Frequency error vs. Voltage								
Voltage (volts)	0minutes		2minutes		5minutes		10minutes	
	Frequency (MHz)	(%)	Frequency (MHz)	(%)	Frequency (MHz)	(%)	Frequency (MHz)	(%)
138	509.0504	0.00008	509.0492	-0.00016	509.0502	0.00004	509.0489	-0.00022
120	509.0497	-0.00006	509.0487	-0.00026	509.0507	0.00014	509.0492	-0.00016
102	509.0489	-0.00022	509.0488	-0.00024	509.0503	0.00006	509.0489	-0.00022

Frequency error vs. Temp								
Temp (°C)	0minutes		2minutes		5minutes		10minutes	
	Frequency (MHz)	(%)	Frequency (MHz)	(%)	Frequency (MHz)	(%)	Frequency (MHz)	(%)
50	509.0491	-0.00018	509.0481	-0.00037	509.0492	-0.00016	509.0488	-0.00024
40	509.0488	-0.00024	509.0492	-0.00016	509.0509	0.00018	509.0492	-0.00016
30	509.0507	0.00014	509.0486	-0.00028	509.0488	-0.00024	509.0487	-0.00026
20	509.0498	-0.00004	509.0502	0.00004	509.0491	-0.00018	509.0505	0.00010
10	509.0489	-0.00022	509.0488	-0.00024	509.0482	-0.00035	509.0492	-0.00016
0	509.0487	-0.00026	509.0492	-0.00016	509.0502	0.00004	509.0497	-0.00006
-10	509.0486	-0.00028	509.0508	0.00016	509.0509	0.00018	509.0492	-0.00016
-20	509.0509	0.00018	509.0489	-0.00022	509.0487	-0.00026	509.0506	0.00012
-30	509.0505	0.00010	509.0484	-0.00031	509.0503	0.00006	509.0487	-0.00026

4.3 Modulation Deviation measurement

4.3.1 Limits of modulation Deviation measurement

Modulation Deviation	Limit
Refer as FCC 74.861 (e) (3) RSS-210 G.5	±75 kHz

4.3.2 Test instruments

Description & manufacturer	Model no.	Serial no.	Calibrated date	Calibrated until
Modulation Analyzer	8901B	3226A04414	04/23/2019	04/23/2020
Function/Arbitrary Waveform Generator	33220A	MY44016131	03/11/2019	03/11/2020
50GHz Spectrum Analyzer	N9030B (PXA)	MY57140597	06/05/2019	06/05/2020

4.3.3 Test procedure

Audio frequency response

- a) Connect the equipment as illustrated.
- b) Set the test receiver to measure peak position deviation. Set the audio bandwidth for ≤ 50 Hz to ≥ 15000 Hz. Turn the de-emphasis function off.
- c) Adjust the transmitter per the manufacturer's procedure for full rated system deviation.
- d) Apply a 1000 Hz tone and adjust the audio frequency generator to produce 20% of the rated system deviation.
- e) Set the test receiver to measure rms deviation and record the deviation reading as DEV_{REF} .
- f) Set the audio frequency generator to the desired test frequency between 300 Hz and 3000 Hz.
- g) Record the test receiver deviation reading as DEV_{FREQ} .
- h) Calculate the audio frequency response at the present frequency as follows:

$$\text{audio frequency response} = 20 \log_{10} \left(\frac{DEV_{FREQ}}{DEV_{REF}} \right)$$

- i) Repeat step f) through step h) for all the desired test frequencies.

Modulation limiting

- a) Connect the equipment as illustrated.
- b) Adjust the transmitter per the manufacturer's procedure for full rated system deviation.
- c) Set the test receiver to measure peak positive deviation. Set the audio bandwidth for ≤ 0.25 Hz to 15000 Hz. Turn the de-emphasis function off.
- d) Apply a 1000 Hz modulating signal to the transmitter from the audio frequency generator, and adjust the level to obtain 60% of full rated system deviation. This is the 0 dB reference level.
- e) Increase the level from the audio generator by 20 dB in 5 dB increments recording the deviation as measured from the test receiver in each step. Verify that the audio level used to make the OBW measurement is included in the sweep.
- f) Repeat for step e) at 300 Hz, 2500 Hz and 3000 Hz at a minimum using the 0 dB reference level obtained in step d).
- g) Set the test receiver to measure peak negative deviation and repeat step d) through step f).
- h) The values recorded in step f) and step g) are the modulation limiting.

4.3.4 Test setup

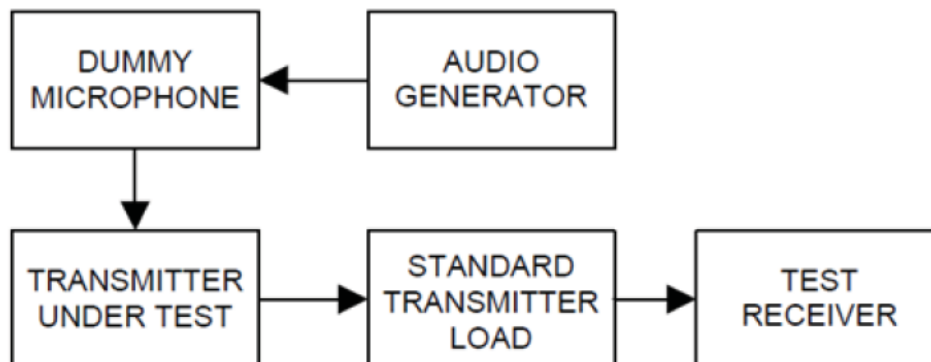

4.3.5 Test results

Modulation Limit

BTR-80N FD

Carrier Frequency: 491.05 MHz

Modulation Level (dB)	Peak freq. Deviation (kHz)				Limit (kHz)
	300Hz	1000Hz	2500Hz	3000Hz	
-20	27.4	30.2	31.6	33.6	± 75
-15	28.3	30.9	31.9	33.8	± 75
-10	29.8	31.3	32.5	35.2	± 75
-5	30.2	34.2	34.6	35.9	± 75
0	34.4	42.4	45.3	50.3	± 75
5	45.9	58.4	57.9	60.1	± 75
10	56.1	60.2	59.3	62.4	± 75
15	62.5	63.8	60.7	63.8	± 75
20	63.4	64.5	63.8	64.6	± 75

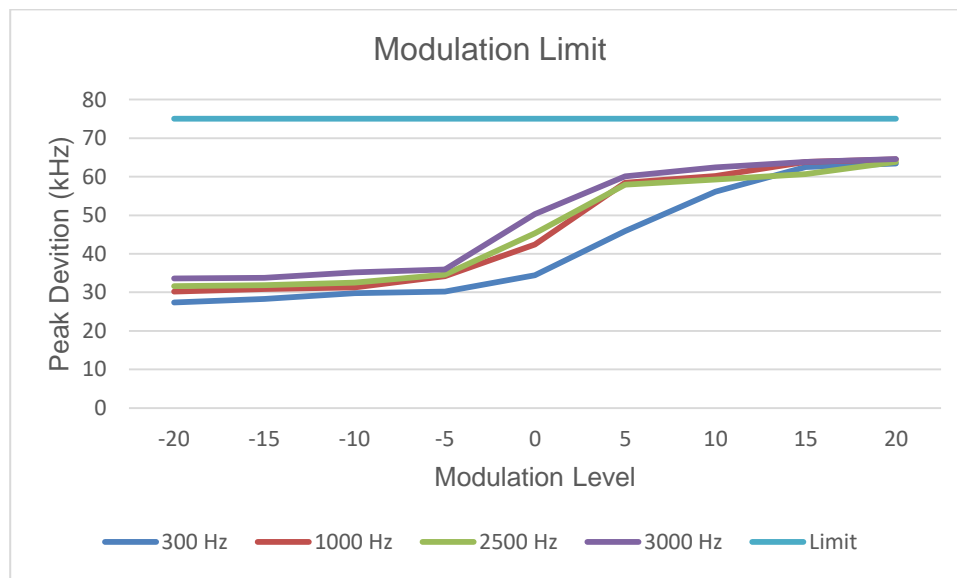

Audio Frequency Response (Middle Channel)

Modulation Frequency (Hz)	Input Level (mw)	Audio Frequency Response (dB)
100	24.47	1.42
300	23.84	1.19
500	22.57	0.72
700	21.35	0.24
1000	20.78	0
1500	18.39	-1.06
2000	16.28	-2.12
2500	14.46	-3.15
3500	12.63	-4.32
5000	11.39	-5.22

Note: AF Response = $20 \cdot \log(\text{AF Level} / \text{AF Level of 1 kHz})$

Modulation Limit

BTR-80N HE

Carrier Frequency: 509.05 MHz

Modulation Level (dB)	Peak freq. Deviation (kHz)				Limit (kHz)
	300Hz	1000Hz	2500Hz	3000Hz	
-20	25.3	29.3	32.4	33.2	±75
-15	26.5	30.1	32.8	34.2	±75
-10	27.9	30.8	33.2	35.1	±75
-5	29.2	33.7	35.3	35.8	±75
0	32.4	41.9	44.2	49.7	±75
5	45.2	57.2	56.2	59.2	±75
10	55.8	61.4	58.6	61.3	±75
15	60.2	64.2	63.2	63.6	±75
20	62.7	65.8	65.8	64.9	±75

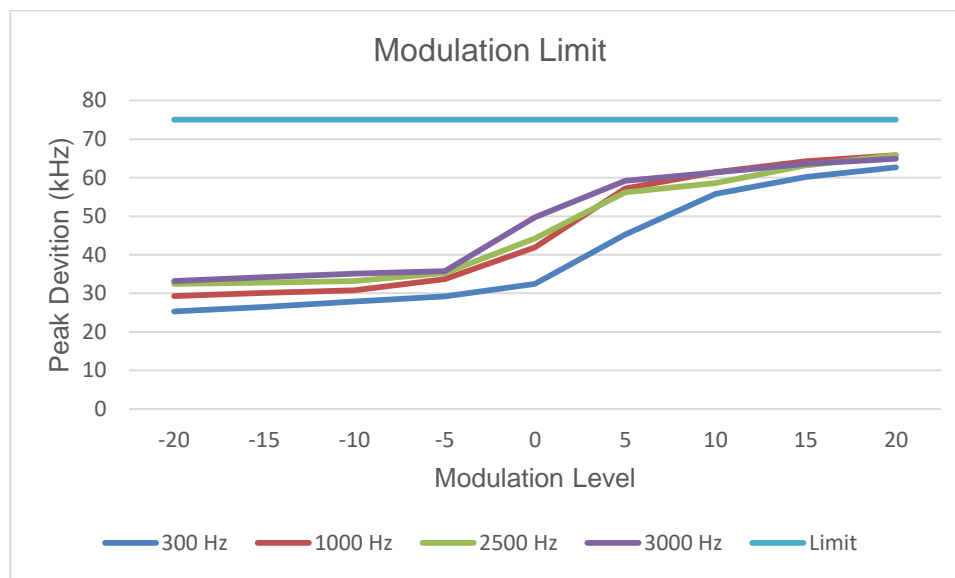

Audio Frequency Response (Middle Channel)

Modulation Frequency (Hz)	Input Level (mw)	Audio Frequency Response (dB)
100	25.83	1.74
300	24.23	1.19
500	23.07	2.39
700	22.34	0.48
1000	21.13	0
1500	19.37	-0.76
2000	17.53	-1.62
2500	14.27	-3.41
3500	12.56	-4.52
5000	10.76	-5.86

Note: AF Response = $20 \cdot \log(\text{AF Level} / \text{AF Level of 1 kHz})$

4.4 Occupied bandwidth and emission Mask measurement

4.4.1 Limits of occupied bandwidth and emission Mask measurement

According to FCC 74.861 (e) (3) any form of modulation may be used. A maximum deviation of ± 75 kHz is permitted when frequency modulation is employed.

(5) The operating bandwidth shall not exceed 200 kHz.

(7) Analog emissions within the band from one megahertz below to one megahertz above the carrier frequency shall comply with the emission mask in section 8.3.1.2 of the European Telecommunications Institute Standard ETSI EN 300 422-1 v1.4.2 (2011-08), Electromagnetic compatibility and Radio spectrum Matters (ERM); Wireless microphones in the 25 MHz to 3 GHz frequency range; part 1: Technical characteristics and methods of measurement. Digital emissions within the band from one megahertz below to one megahertz above the carrier frequency shall comply with the emission mask in section 8.3.2.2 (Figure 4) of the European Telecommunications Institute Standard ETSI EN 300 422-1 v1.4.2 (2011-08), Electromagnetic compatibility and Radio spectrum Matters (ERM); Wireless microphones in the 25 MHz to 3 GHz frequency range; part 1: Technical characteristics and methods of measurement. Beyond one megahertz below and above the carrier frequency, emissions shall comply with the limits specified in section 8.4 of ETSI EN 300 422-1 v1.4.2 (2011-08). The requirements of this paragraph (e)(7) shall not apply to applications for certification of equipment in these bands until nine months after release of the Commission's Channel Reassignment Public Notice, as defined in §73.3700(a)(2) of this chapter;

4.4.2 Test instruments

Description & manufacturer	Model no.	Serial no.	Calibrated date	Calibrated until
50GHz Spectrum Analyzer	N9030B (PXA)	MY57140597	06/05/2019	06/05/2020
Function/Arbitrary Waveform Generator	33220A	MY44016131	03/10/2019	03/10/2020
30dB Attenuation	VAT-30W2	N/A	N/A	N/A

4.4.3 Test setup

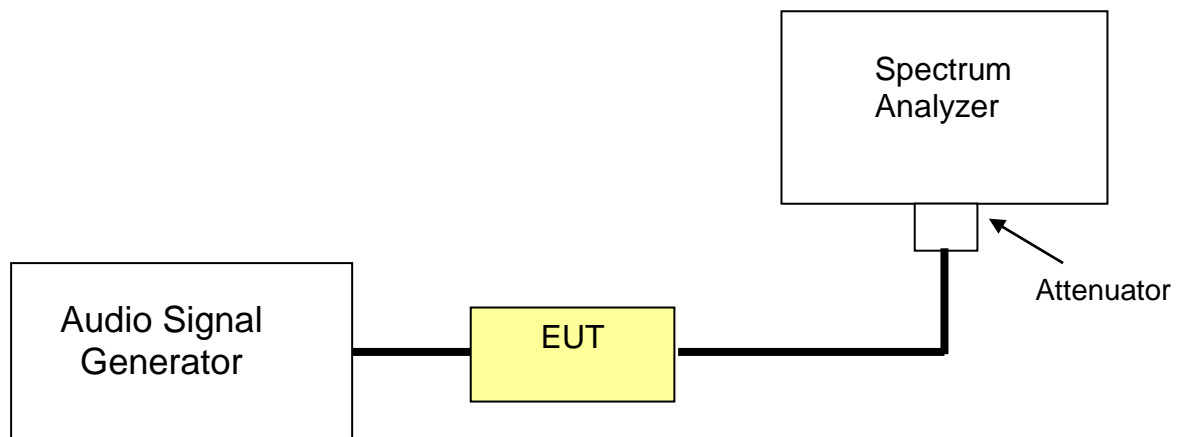

4.4.4 Test procedures

The OBW is according to KDB 971168 D01v03r01

The Emission Mask is according to section 8.3 of ETSI EN 300 422-1 V1.4.2 (2011-08).

4.4.5 Test results

Band	Frequency (MHz)	99% Bandwidth (kHz)	Limit (kHz)	Result
BTR-80N FD	482.225	12.39	200	Pass
	491.050	14.39	200	Pass
	499.975	15.03	200	Pass
BTR-80N HE	500.225	13.08	200	Pass
	509.050	13.53	200	Pass
	517.975	13.98	200	Pass

Bandwidth Test Plots

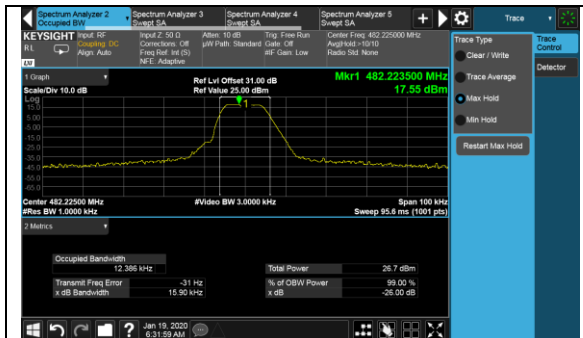

BTR-80N FD - Low Channel

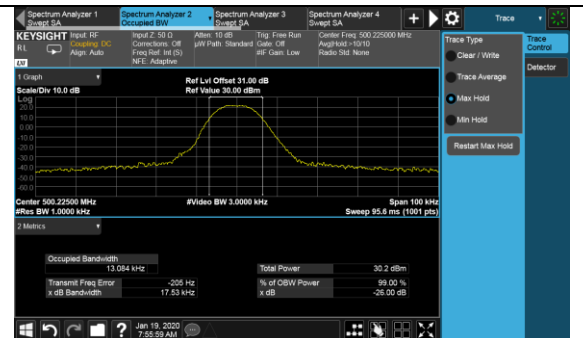

BTR-80N HE - Low Channel

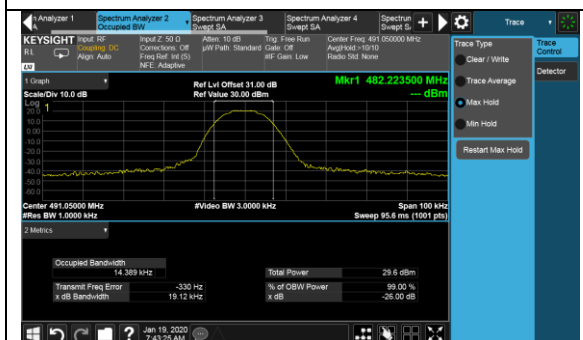

BTR-80N FD - Middle Channel

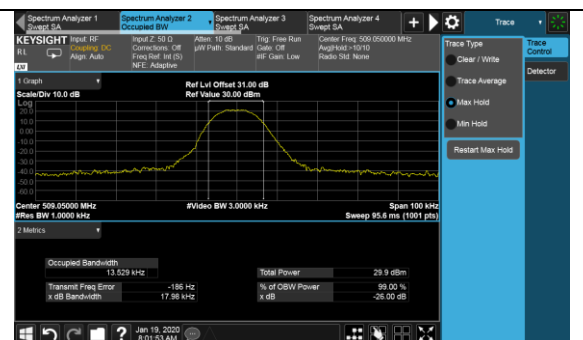

BTR-80N HE - Middle Channel

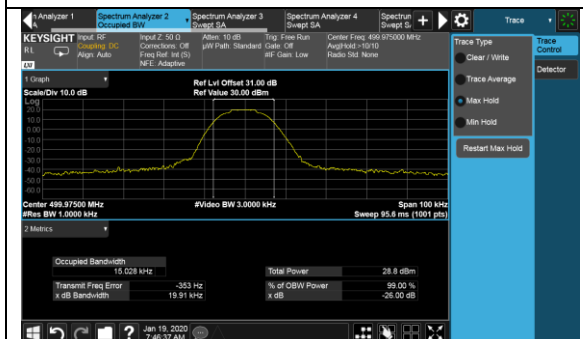

BTR-80N FD - High Channel

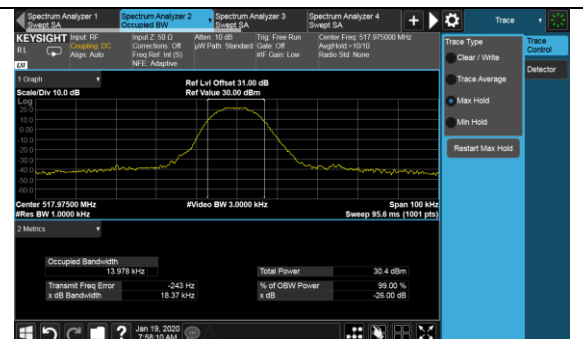

BTR-80N HE - High Channel

Emission Mask Test Plots

BTR-80N FD:



Low Channel, Reference

Low Channel, Mask



Middle Channel, Reference

Middle Channel, Mask



High Channel, Reference

High Channel, Mask

BTR-80N HE:

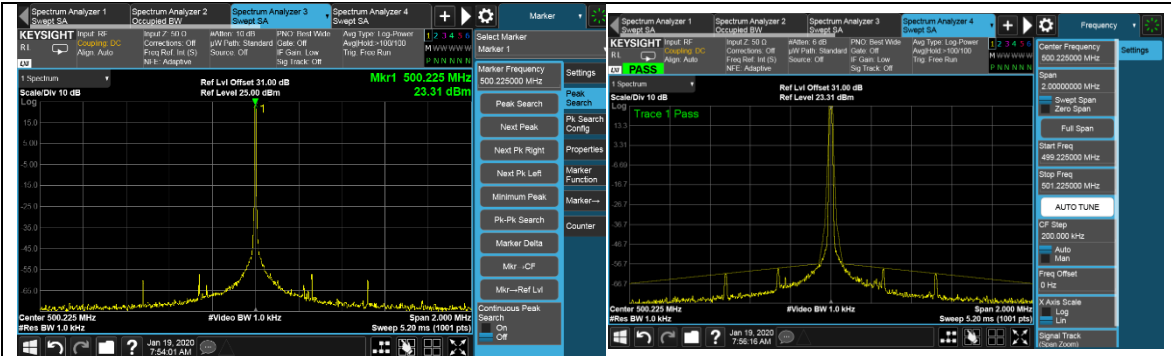

Low Channel, Reference

Low Channel, Mask



Middle Channel, Reference

Middle Channel, Mask

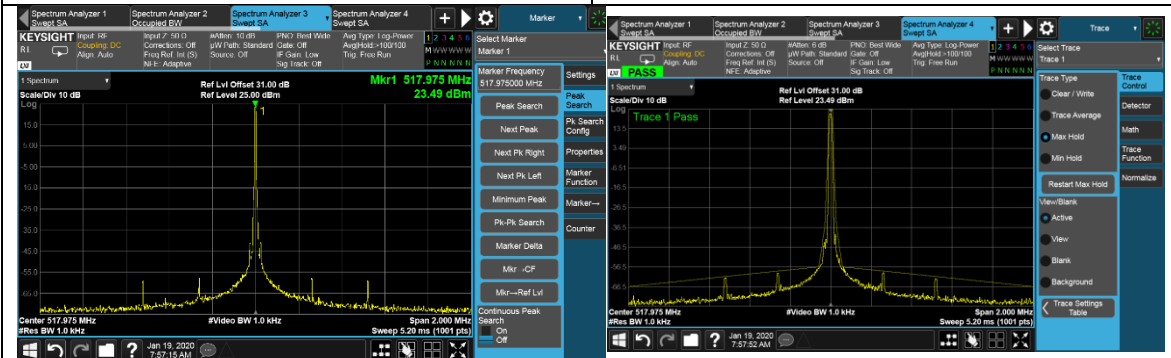

High Channel, Reference

High Channel, Mask

4.5 Conducted spurious emissions

4.5.1 Limits of conducted spurious emissions measurement

According to FCC 74.861 (e) (7) Analog emissions within the band from one megahertz below to one megahertz above the carrier frequency shall comply with the emission mask in section 8.3.1.2 of the European Telecommunications Institute Standard ETSI EN 300 422-1 v1.4.2 (2011-08), Electromagnetic compatibility and Radio spectrum Matters (ERM); Wireless microphones in the 25 MHz to 3 GHz frequency range; part 1: Technical characteristics and methods of measurement. Digital emissions within the band from one megahertz below to one megahertz above the carrier frequency shall comply with the emission mask in section 8.3.2.2 (Figure 4) of the European Telecommunications Institute Standard ETSI EN 300 422-1 v1.4.2 (2011-08), Electromagnetic compatibility and Radio spectrum Matters (ERM); Wireless microphones in the 25 MHz to 3 GHz frequency range; part 1: Technical characteristics and methods of measurement. Beyond one megahertz below and above the carrier frequency, emissions shall comply with the limits specified in section 8.4 of ETSI EN 300 422-1 v1.4.2 (2011-08). The requirements of this paragraph (e)(7) shall not apply to applications for certification of equipment in these bands until nine months after release of the Commission's Channel Reassignment Public Notice, as defined in §73.3700(a)(2) of this chapter.

4.5.2 Test instruments

Description & manufacturer	Model no.	Serial no.	Calibrated date	Calibrated until
50GHz Spectrum Analyzer	N9030B (PXA)	MY57140597	06/05/2019	06/05/2020
30dB Attenuation	VAT-30W2	N/A	N/A	N/A

4.5.3 Test procedure

- a. The EUT was set up for the rated peak power. The power was measured with spectrum analyzer. All measurements were done at 3 channels: low, middle and high operational frequency range.
- b. When the spectrum scanned from 30 MHz to 26.5 GHz, it shall be connected to spectrum analyzer via an attenuator. The spectrum set RBW = 100 kHz, VBW = 300 kHz while below 1GHz and set RBW = 1 MHz, VBW = 3 MHz with above 1GHz.

4.5.4 Test setup

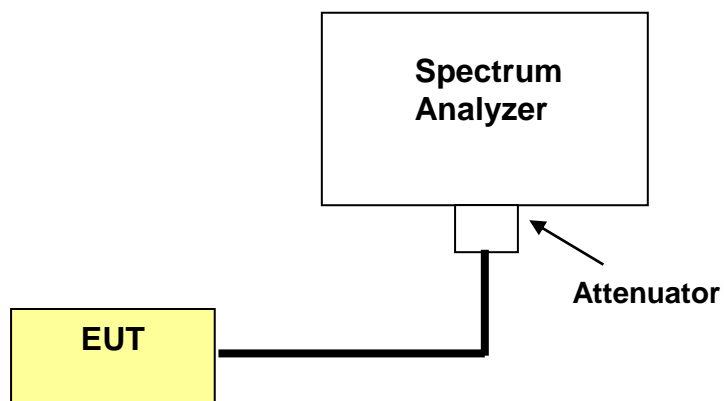

4.5.5 EUT operating conditions

Same as item 4.1.5

4.5.6 Test results

BTR-80N FD:

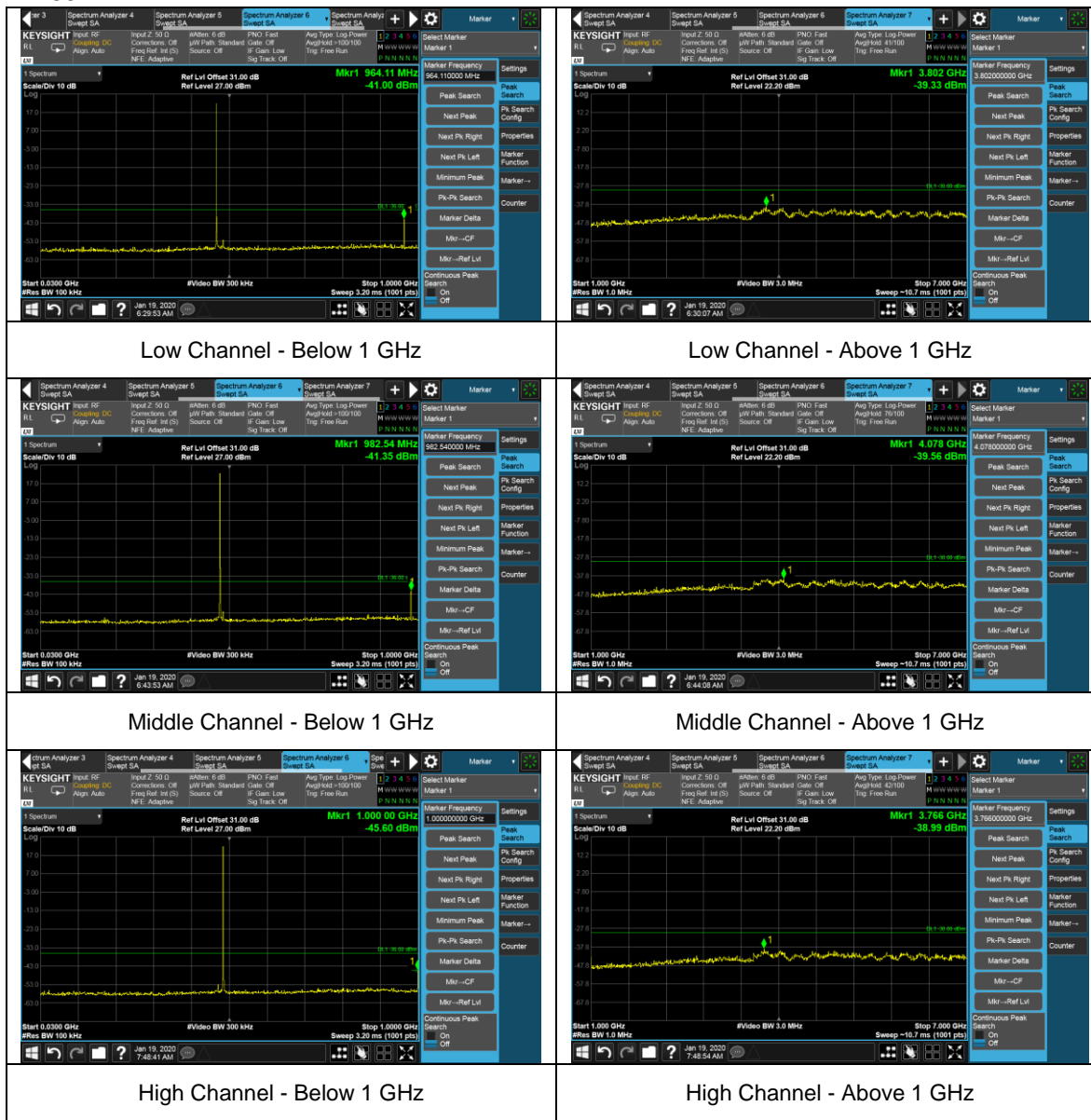

BTR-80N HE:

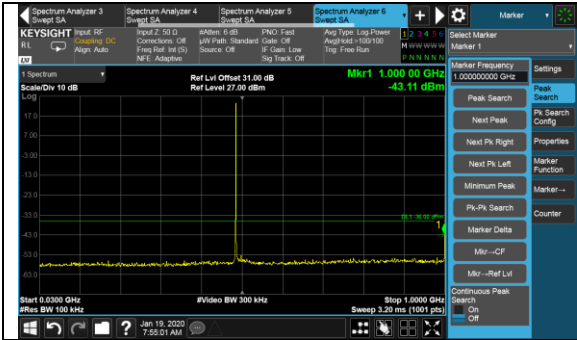

Low Channel - Below 1 GHz

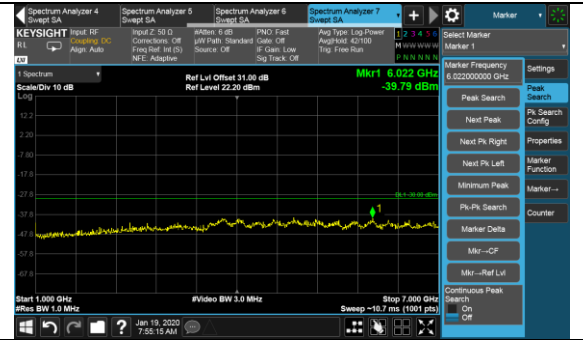

Low Channel - Above 1 GHz

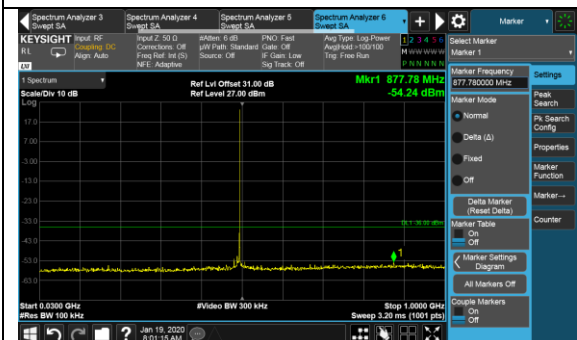

Middle Channel - Below 1 GHz



Middle Channel - Above 1 GHz

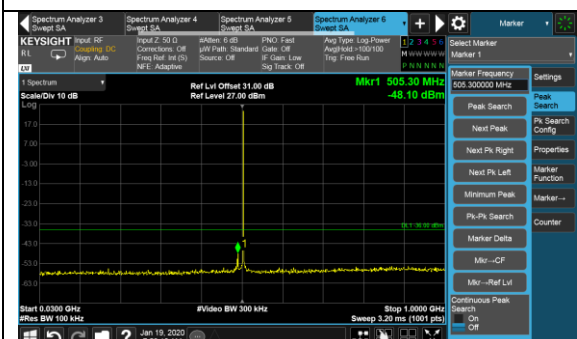

High Channel - Below 1 GHz

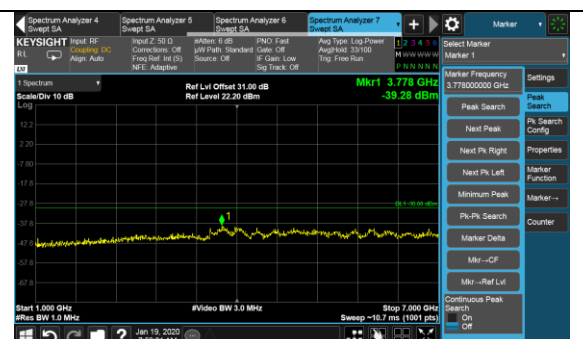

High Channel - Above 1 GHz

4.6 Radiated emission measurement

4.6.1 Limits of radiated emission measurement

According to FCC 74.861 (e) (7) Analog emissions within the band from one megahertz below to one megahertz above the carrier frequency shall comply with the emission mask in section 8.3.1.2 of the European Telecommunications Institute Standard ETSI EN 300 422-1 v1.4.2 (2011-08), Electromagnetic compatibility and Radio spectrum Matters (ERM); Wireless microphones in the 25 MHz to 3 GHz frequency range; part 1: Technical characteristics and methods of measurement. Digital emissions within the band from one megahertz below to one megahertz above the carrier frequency shall comply with the emission mask in section 8.3.2.2 (Figure 4) of the European Telecommunications Institute Standard ETSI EN 300 422-1 v1.4.2 (2011-08), Electromagnetic compatibility and Radio spectrum Matters (ERM); Wireless microphones in the 25 MHz to 3 GHz frequency range; part 1: Technical characteristics and methods of measurement. Beyond one megahertz below and above the carrier frequency, emissions shall comply with the limits specified in section 8.4 of ETSI EN 300 422-1 v1.4.2 (2011-08). The requirements of this paragraph (e)(7) shall not apply to applications for certification of equipment in these bands until nine months after release of the Commission's Channel Reassignment Public Notice, as defined in §73.3700(a)(2) of this chapter.

According to RSS-210 Annex G.4 Transmitter unwanted emissions

The transmitter unwanted emissions shall meet and be measured according to the requirements in sections 8.3 and 8.4 of ETSI EN 300 422-1.

4.6.2 Test instruments

Description & Manufacturer	Model No.	Serial No.	Calibrated Date	Calibrated Until
Keysight Signal Generator	MXG N5182A	MY47071065	06/28/2019	06/28/2020
50GHz Spectrum Analyzer	N9030B (PXA)	MY57140374	07/22/2019	07/22/2020
Preamplifier RF-Lambda	RAMP00M50GA	17032300047	09/19/2019	09/19/2020
RF Preamplifier	LPA-6-30	11170602	05/06/2019	05/06/2020
Hybrid Antenna SUNAR	JB6	A111717	03/09/2019	03/09/2020
DRG Horn Antenna ETS LINDGREN	3117	214309	11/22/2019	11/22/2020
Tuned Dipole Antenna 30 - 1000 MHz (4pcs set)	AD-100	40133	01/23/2018	01/23/2020

4.6.3 Test procedures

1. The power was measured with spectrum analyzer. All measurements were done at the worst channel. (low, middle and high channel of operational frequency range.)
2. Substitution method is used for EIRP measurement. In the open area test site, EUT placed on the 0.8m height of turn table, rotated the table around 360 degrees to search the maximum radiation power and receiver antenna shall be rotated vertical and horizontal polarization and moved height from 1m to 4m to find the maximum polar radiated power. The “read value” is the spectrum reading the maximum power value.
3. The substitution antenna is substituted for EUT at the same position and signals generator export the CW signal to the substitution antenna via a TX cable. Rotated the turn table and moved receiving antenna to find the maximum radiation power. Adjust output power level of S.G to get a value of spectrum reading equal to “read value “ of step b. Record the power level of S.G
4. $EIRP = \text{output power level of S.G} - \text{TX cable loss} + \text{antenna gain of substitution antenna}$.

Note: the resolution bandwidth and video bandwidth of test receiver/spectrum analyzer is 1MHz/3MHz

4.6.4 Deviation from test standard

No deviation

4.6.5 Test setup

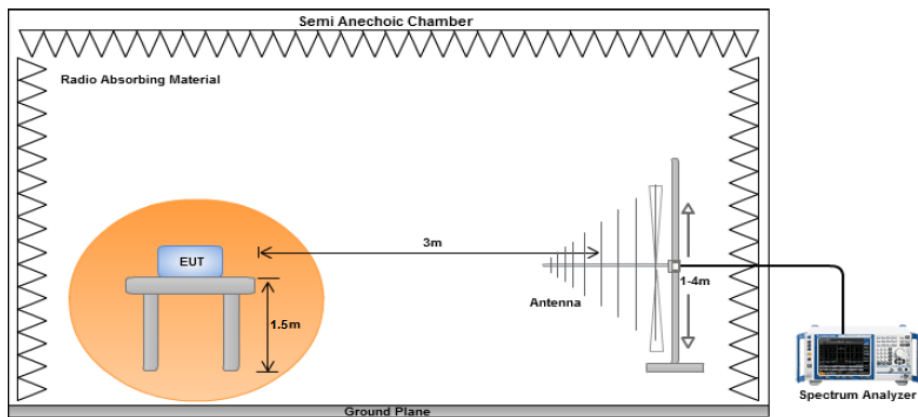

Test Setup below 1GHz

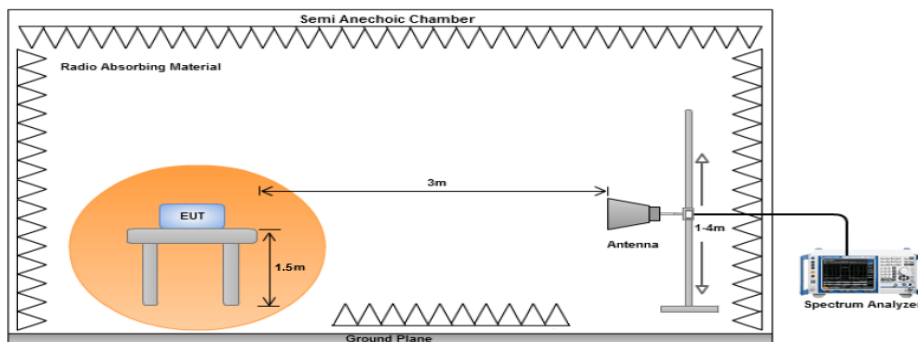

Test Setup above 1GHz

For the actual test configuration, please refer to the related item – photographs of the test configuration.

4.6.6 EUT operating conditions

Same as item 4.1.5

4.6.7 Test results

BTR-80N FD:

Below 1GHz Worst-case Data

OPERATING STATE	Transmitting	SPURIOUS EMISSION FREQUENCY RANGE	30MHz ~ 1GHz
------------------------	--------------	--	--------------

Indicated			Test Antenna		Substituted						
Freq (MHz)	Raw (dBm)	Deg	Hgt (cm)	Pol (V/H)	Freq (MHz)	Level (dBm)	Ant Gain (dBi)	Cable Loss (dB)	Absolute Level (dBm)	Limit (dBm)	Margin (dB)
146.2	-69.08	311	166	V	146.2	-65.1	0	0.42	-65.52	-36	-29.52
146.2	-70.73	232	176	H	146.2	-65.63	0	0.42	-66.05	-36	-30.05
982.1	-49.2	238	156	V	982.1	-44.23	0	1.02	-45.25	-36	-9.25
982.1	-51.42	29	190	H	982.1	-46.23	0	1.02	-47.25	-36	-11.25

Above 1GHz

Frequency Range	1GHz ~ 12.75GHz	Operating Channel	482.225 MHz
------------------------	-----------------	--------------------------	-------------

Indicated			Test Antenna		Substituted						
Freq (MHz)	Raw (dBm)	Deg	Hgt (cm)	Pol (V/H)	Freq (MHz)	Level (dBm)	Ant Gain (dBi)	Cable Loss (dB)	Absolute Level (dBm)	Limit (dBm)	Margin (dB)
1446.7	-48.16	188	165	V	1446.7	-43.58	8.87	1.24	-35.95	-30	-5.95
1446.7	-47.2	238	252	H	1446.7	-42.62	8.87	1.24	-34.99	-30	-4.99
1928.9	-49.93	36	166	V	1928.9	-45.35	9.18	1.35	-37.52	-30	-7.52
1928.9	-47.83	126	152	H	1928.9	-43.25	9.18	1.35	-35.42	-30	-5.42

Frequency Range	1GHz ~ 12.75GHz	Operating Channel	491.05 MHz
------------------------	-----------------	--------------------------	------------

Indicated			Test Antenna		Substituted						
Freq (MHz)	Raw (dBm)	Deg	Hgt (cm)	Pol (V/H)	Freq (MHz)	Level (dBm)	Ant Gain (dBi)	Cable Loss (dB)	Absolute Level (dBm)	Limit (dBm)	Margin (dB)
1473.15	-46.53	237	143	V	1473.15	-43.61	9.82	1.25	-35.04	-30	-5.04
1473.15	-47.53	8	187	H	1473.15	-44.68	9.82	1.25	-36.11	-30	-6.11
1964.2	-48.71	109	123	V	1964.2	-43.79	8.79	1.36	-36.36	-30	-6.36
1964.2	-49.39	239	189	H	1964.2	-44.47	8.79	1.36	-37.04	-30	-7.04

Frequency Range	1GHz ~ 12.75GHz	Operating Channel	499.975 MHz
------------------------	-----------------	--------------------------	-------------

Indicated			Test Antenna		Substituted						
Freq (MHz)	Raw (dBm)	Deg	Hgt (cm)	Pol (V/H)	Freq (MHz)	Level (dBm)	Ant Gain (dBi)	Cable Loss (dB)	Absolute Level (dBm)	Limit (dBm)	Margin (dB)
1499.9	-49.28	23	156	V	1499.9	-44.26	9.82	1.24	-35.68	-30	-5.68
1499.9	-48.09	41	177	H	1499.9	-43.07	9.82	1.24	-34.49	-30	-4.49
1999.9	-47.22	199	145	V	1999.9	-46.21	8.79	1.41	-38.83	-30	-8.83
1999.9	-47.67	239	199	H	1999.9	-44.65	8.79	1.41	-37.27	-30	-7.27

REMARKS:

1. Absolute level (dBm) = Level (dBm) + Ant Gain (dBi) – Cable Loss (dB)
2. Margin value = Absolute level – Limit value.

BTR-80N HE:

Below 1GHz Worst-case Data

OPERATING STATE	Transmitting	SPURIOUS EMISSION FREQUENCY RANGE	30MHz ~ 1GHz
------------------------	--------------	--	--------------

Indicated			Test Antenna		Substituted						
Freq (MHz)	Raw (dBm)	Deg	Hgt (cm)	Pol (V/H)	Freq (MHz)	Level (dBm)	Ant Gain (dBi)	Cable Loss (dB)	Absolute Level (dBm)	Limit (dBm)	Margin (dB)
141.05	-66.76	123	154	V	141.05	-62.78	0	0.42	-63.2	-36	-27.2
141.05	-68.6	298	188	H	141.05	-63.56	0	0.42	-63.98	-36	-27.98
468	-64.23	217	198	V	468	-59.55	0	0.65	-60.2	-36	-24.2
468	-65.7	31	290	H	468	-62	0	0.65	-62.65	-36	-26.65

Above 1GHz

Frequency Range	1GHz ~ 12.75GHz	Operating Channel	500.225 MHz
------------------------	-----------------	--------------------------	-------------

Indicated			Test Antenna		Substituted						
Freq (MHz)	Raw (dBm)	Deg	Hgt (cm)	Pol (V/H)	Freq (MHz)	Level (dBm)	Ant Gain (dBi)	Cable Loss (dB)	Absolute Level (dBm)	Limit (dBm)	Margin (dB)
1000.5	-49.68	231	166	V	1000.5	-44.48	7.5	1.03	-38.01	-30	-8.01
1000.5	-48.77	271	232	H	1000.5	-43.68	7.5	1.03	-37.21	-30	-7.21
1500	-51.07	28	179	V	1500	-45.86	9.82	1.24	-37.28	-30	-7.28
1500	-51.24	187	281	H	1500	-44.39	9.82	1.24	-35.81	-30	-5.81

Frequency Range	1GHz ~ 12.75GHz	Operating Channel	509.05 MHz
------------------------	-----------------	--------------------------	------------

Indicated			Test Antenna		Substituted						
Freq (MHz)	Raw (dBm)	Deg	Hgt (cm)	Pol (V/H)	Freq (MHz)	Level (dBm)	Ant Gain (dBi)	Cable Loss (dB)	Absolute Level (dBm)	Limit (dBm)	Margin (dB)
1018	-47.8	329	128	V	1018	-42.7	7.5	1.03	-36.23	-30	-6.23
1018	-49.86	172	187	H	1018	-43.57	7.5	1.03	-37.1	-30	-7.1
1527.2	-49.71	238	176	V	1527.2	-44.65	9.82	1.24	-36.07	-30	-6.07
1527.2	-51.97	318	188	H	1527.2	-45.75	9.82	1.24	-37.17	-30	-7.17

Frequency Range	1GHz ~ 12.75GHz	Operating Channel	517.975 MHz
------------------------	-----------------	--------------------------	-------------

Indicated			Test Antenna		Substituted						
Freq (MHz)	Raw (dBm)	Deg	Hgt (cm)	Pol (V/H)	Freq (MHz)	Level (dBm)	Ant Gain (dBi)	Cable Loss (dB)	Absolute Level (dBm)	Limit (dBm)	Margin (dB)
1036	-49.89	120	126	V	1036	-44.69	7.5	1.03	-38.22	-30	-8.22
1036	-49.21	329	198	H	1036	-44.14	7.5	1.03	-37.67	-30	-7.67
1554	-52.6	0	127	V	1554	-47.37	9.82	1.24	-38.79	-30	-8.79
1554	-50.94	129	187	H	1554	-45.91	9.82	1.24	-37.33	-30	-7.33

REMARKS:

1. Absolute level (dBm) = Level (dBm) + Ant Gain (dBi) – Cable Loss (dB)
2. Margin value = Absolute level – Limit value.

7 Photographs of the test configuration

Please refer to the attached file (test setup photo).

8 Information Of The Testing Laboratories

Bureau Veritas is a global leader in testing, inspection and certification (TIC) services. We help businesses improve safety, sustainability and productivity; and our clients include the majority of leading brands in retail, manufacturing and other industries. With a presence in every major country around the world, our quality assurance and compliance solutions are vital in helping our customers enhance product quality and concept-to-consumer journeys. We also assist with increasing speed to market, profitability and brand equity throughout the supply chain. Bureau Veritas is a leading wireless/IoT testing, inspection, audit and certification provider, with a global network of test laboratories to support the IoT industry in areas of connectivity, security, interoperability as well as quality, health & safety, and environmental/chemical requirements.

If you have any comments, please feel free to contact us at the following:

Milpitas EMC/RF/Safety/Telecom Lab

775 Montague Expressway, Milpitas, CA 95035
Tel: +1 408 526 1188

Sunnyvale OTA/Bluetooth Lab

1293 Anvilwood Avenue, Sunnyvale, CA
94089
Tel: +1 669 600 5293

Littleton EMC/RF/Safety/Environmental Lab

1 Distribution Center Cir #1, Littleton, MA 01460
Tel: +1 978 486 8880

Irvine OTA/PTCRB/Bluetooth/V2X Lab

15 Musick, Irvine, CA 92618
Tel: +1 949 716 6512

Email: sales.eaw@us.bureauveritas.com

Web Site: www.cpsusa-bureauveritas.com

The address and road map of all our labs can be found in our web site also.

--- END ---