

## *BTR-800, TR-800, TR-825 Professional Wireless Intercom System*

### *Operating Instructions*





# Table of Contents

<b>INTRODUCTION</b> .....	7	Portable Station Connect .....	38
General Description .....	7	Intercom A and B .....	38
System Features .....	7	Auxiliary .....	38
		Display Contrast .....	39
<b>BTR-800 BASE STATION</b> .....	<b>9</b>	BTR-800 Menu Structure .....	40
Controls and Connections – Front Panel .....	9	Main Screen Flowchart .....	40
BTR-800 Specifications .....	11	Power-Up Screen .....	41
		Operating Screen .....	41
<b>TR-800 BELTPACK</b> .....	<b>13</b>	Beltpack Activity Code Definitions .....	42
Controls and Connections – Top Panel .....	13	Group/Channel Select .....	43
TR-800 Specifications .....	15	Group/Frequency Select .....	44
		Frequency Edit (User-Programmed Groups Only) .....	45
<b>TR-825 BELTPACK</b> .....	<b>17</b>	ClearScan™ .....	46
Controls and Connections – Top Panel .....	17	Special Key Sequences .....	47
TR-825 Specifications .....	19	Lockout .....	47
		Copy .....	47
<b>INITIAL EQUIPMENT SETUP</b> .....	<b>21</b>	1st Use Default .....	47
Unpacking .....	21	Factory Default .....	47
Antenna Connection .....	22	Beltpack Operation .....	48
Antenna Polarization .....	22	On/Off and Volume Control .....	48
Distance between Antennas .....	22	Battery Check .....	48
Antenna Placement .....	22	Talk Button .....	48
Improving Reception and Increasing Range .....	24	Microphone Gain .....	48
Base Station Set-up .....	25	Audio Channel Select Button .....	48
Location .....	25	Stage Announce (SA) .....	48
Power Connection .....	25	Wireless Talk Around (WTA) .....	48
Transmit Switches .....	25	TR-800 Menu Structure .....	49
Internal Transmit Switches .....	26	Beltpack Menu Structure .....	49
Intercom Switch .....	26	Power-Up Screens .....	50
Intercom Interface .....	26	Group/Channel Screen .....	51
Dual Listen Functionality .....	28	Transmit Screen .....	52
Auxiliary Input/Output .....	29	Receive 1 Screen .....	53
Internal Auxiliary Input Routing Switch .....	29	Receive 2 Screen .....	54
Stage Announce / Relay Contacts .....	30	ClearScan™ .....	55
Base Station Link .....	31	Stage Announce Enable/Disable .....	56
Beltpack Setup .....	32	Wireless Talk Around Enable/Disable .....	56
Antenna Connection .....	33	Audio Channel A or B Disable/Enable .....	57
Transmit Mode .....	33	Talk Button Latch on/Latch off .....	57
Headset Connection .....	33	Special Key Sequences .....	58
		Lockout .....	58
<b>PRE-WALK-THRU CHECKLIST</b> .....	<b>35</b>	1st Use Default .....	58
		Factory Default .....	58
<b>SYSTEM OPERATION</b> .....	<b>37</b>	TR-825 Menu Structure .....	59
Frequency Plan Overview .....	37	Beltpack Menu Structure .....	59
Factory-Defined Groups .....	37	Power-Up Screens .....	60
User-Programmable Groups .....	37	Group/Channel Screen .....	61
System Quick Start .....	37	Transmit Screen .....	62
Base Station Operation .....	38	Receive 1 Screen .....	63
Power .....	38	Receive 2 Screen .....	64
Local Headset .....	38	Audio Output .....	65
		ClearScan™ .....	66
		Stage Announce Enable/Disable .....	67

---

Wireless Talk Around .....	68
Audio Channel A Options .....	69
Audio Channel B Options .....	70
Special Key Sequences .....	71
Lockout .....	71
1st Use Default .....	71
Factory Default .....	71
<b><i>SYSTEM WALK-THRU</i></b> .....	<b>73</b>
<b><i>TROUBLESHOOTING</i></b> .....	<b>75</b>
<b><i>TECH TIPS</i></b> .....	<b>77</b>
Frequency Interaction .....	77
Microphone Gain Adjustment .....	77
<b><i>BATTERY INFORMATION</i></b> .....	<b>79</b>
Cold Temperatures and Batteries .....	79
Battery Life: .....	79
Battery Warnings .....	79
<b><i>INTERCOM SYSTEMS</i></b> <b><i>SPECIFICATIONS</i></b> .....	<b>81</b>
<b><i>ACCESSORIES AND REPLACEMENT</i></b> <b><i>PARTS</i></b> .....	<b>83</b>
<b><i>CERTIFICATION INFORMATION</i></b> .....	<b>87</b>
<b><i>THREE BAND BASE STATIONS</i></b> .....	<b>89</b>
Identifying a Three Band Unit .....	89
Regulatory Changes and the Three Band .....	89
Changing Channel Maps .....	89

---

### *General Description*

The RTS BTR-800 UHF Synthesized Wireless intercom systems offer the ultimate in reliable, high performance, high-fidelity, full-duplex communications. The BTR-800 system includes the BTR-800 frequency agile base station, working with up to four TR-800 or TR-825 frequency agile belt packs. The BTR-800 base station provides full-duplex communications with the belt packs.

The BTR system incorporates two audio channel operation, permitting the belt pack operator to choose between two separate audio channels of communications, with the base station tracking the belt pack selection. This allows the user the flexibility to create a party-line and a private line within the same belt pack.

The BTR-800 system is perfectly suited for stand-alone operation and also can interface with Audiocom (Telex), RTS TW, Clear-Com, as well as RTS Matrix systems and other 4-wire communications systems. In addition to the external intercom systems interfaces listed above, the system provides connections for auxiliary balanced audio input and output, as well as wireless talk-around (WTA) and stage announce (SA) features.

The RTS BTR series has been designed for reliable, efficient operation. Operating in the 470 to 722 MHz range, the units operate reliably at line-of-sight distances of 1,000 feet. With available antenna systems, from Bosch, the effective operating range can be extended. The high efficiency belt packs provide up to 12 hours of uninterrupted operation using standard alkaline batteries.

---

### *System Features*

- Frequency-agile base station and belt packs. No external computer/device required to select frequencies.
- Backlit base-station LCD allows the user to easily monitor the belt pack's status as well as change base station frequencies.
- ClearScan™ function on base station and belt pack to automatically find the best channels on which to operate.
- Full-duplex (simultaneous talk and listen) operation.
- Compatible with Audiocom, RTS TW, Matrix, Clear-Com®, and other wired intercom types.
- Two channels of intercom audio.
- WTA (Wire less Talk Around) belt pack control. This feature allows belt packs to talk to each other, but their audio is lifted from any wired system connected to the base station.
- SA (Stage Announce) belt pack control. Allows the user to direct their audio to a jack on the back of the base for P.A. systems or other external audio systems.
- Relay contact closure on the base when the SA button is pressed.
- TR-825 features two audio channel binaural operation in either stereo or mono mode.
- Belt pack units contained in a weather and shock resistant die-cast magnesium case.
- Convenient IEC power connector on the base station so the unit can plug directly to outlets. No in-line or wall plug power supply.
- Base station comes with rack ears for easy rack mounting.

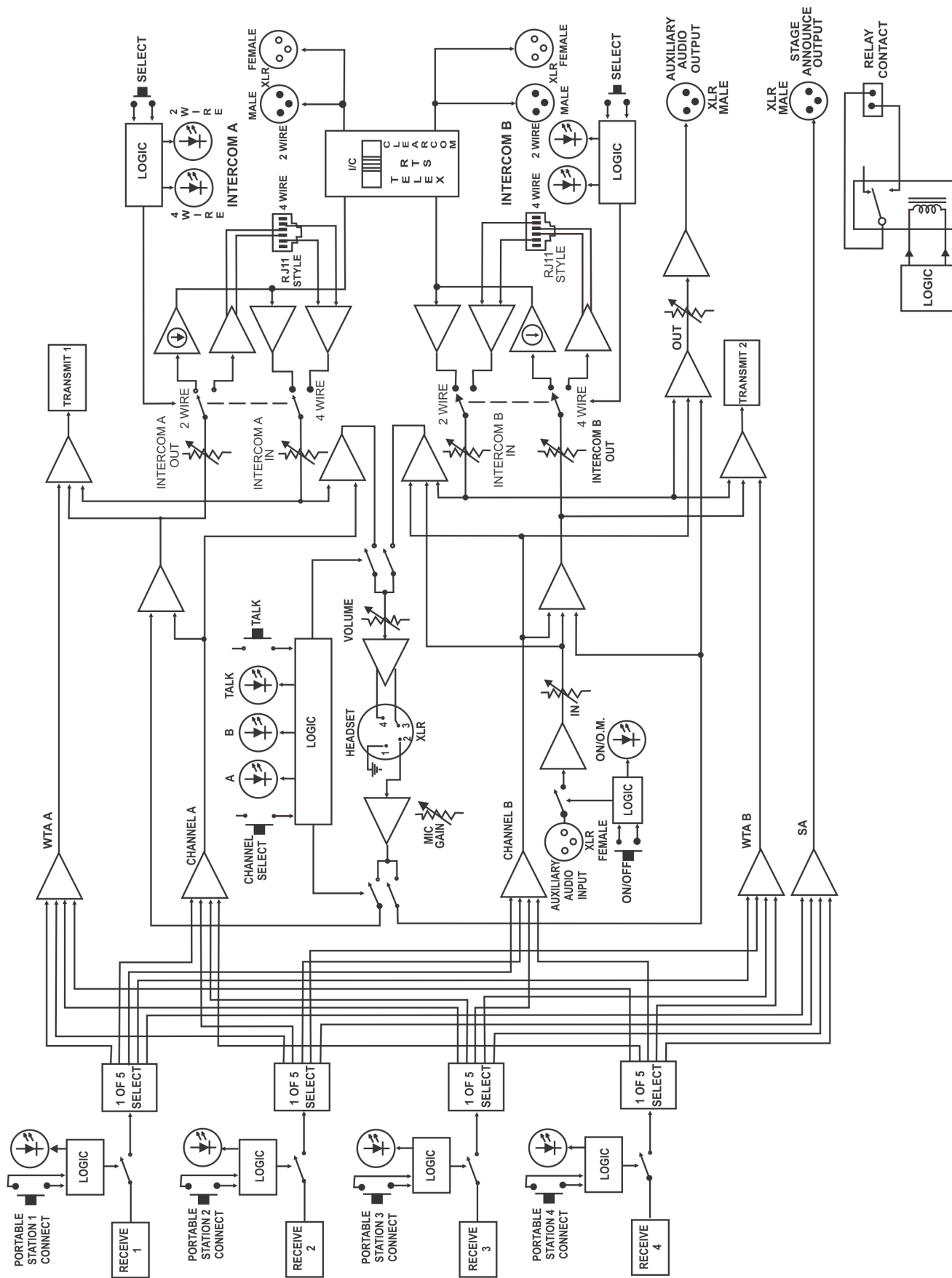
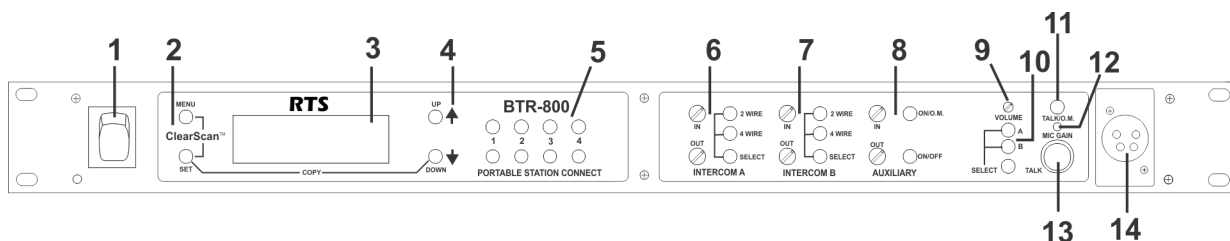


FIGURE 1. BTR-800 Block Diagram

# BTR-800 Base Station

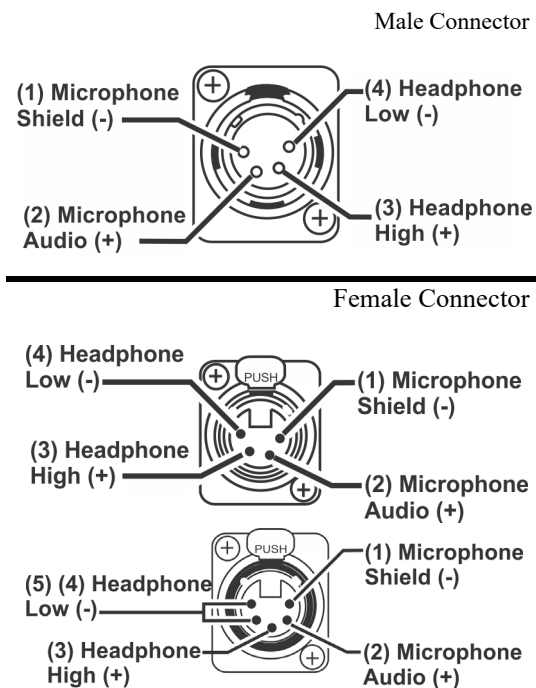
## Controls and Connections – Front Panel



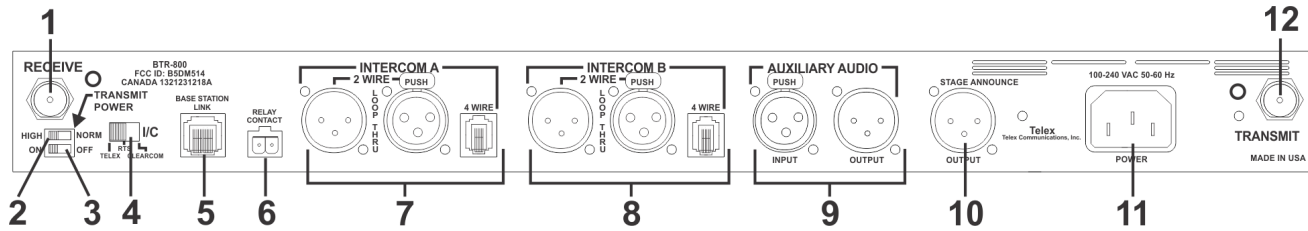
1. **Power Switch**
2. **[MENU] and [SET] buttons** - Use to select menus and set options on the LCD.
3. **Backlit Graphics LCD (Liquid Crystal Display)**
4. **[UP] and [DOWN] buttons** - Use to select base station options on the LCD.
5. **Portable Station Connect** - Use buttons to enable or disable the respective receiver's audio. GREEN LED - Audio enabled, LED OFF - Audio disabled.
6. **Intercom A Controls** – Wired intercom A interface controls. Audio input and output level controls. 2-wire or 4-wire select button with green LED indicator lights. Selected LED will change to RED if the input levels are too high.
7. **Intercom B Controls** – Wired intercom B interface controls. Audio input and output level controls. 2-wire or 4-wire select button with green LED indicator lights. Selected LED will change to RED if the input levels are too high.
8. **Auxiliary Controls** – Wired auxiliary interface controls. Audio input and output level controls. GREEN LED = Aux. input enabled. LED will change to RED if the input levels are too high.
9. **Headset Volume** – Controls the volume to the headset connection to #14.
10. **Headset Intercom Select** – Controls the intercom to which the local headset is connected. Each press of the button changes the connection; channel A, channel B, or both.
11. **Talk/Overmod Light** – LED is green when talk button #13 is active. A normal mic gain setting will cause the LED to flash red on the loudest speech levels. If the gain is too high, the LED is red at normal speech volumes.
12. **Microphone Gain** – Adjust the headset's microphone gain. Adjusts so that the overmod light #11 flashes from green to red on loudest speech.
13. **Talk Button** - Press to enable the audio path from the local handset. LED #11 turns green when enabled. A quick press and

release latches button on. If the talk function is latched on, pressing the talk button again turns it off.

14. **Local Headset Connector** - Male XLR connector or female XLR. A dynamic or electret headset microphone is automatically detected.



**FIGURE 2.**  
**Local Headset Wiring**



**FIGURE 3.**  
**BTR-800 - Rear Panel**

1. **Receive Antenna** – Female TNC Connector. Color band on antenna must match color dot on base station.
2. **Transmit Power Switch** – HIGH = Transmitters at full power. NORMAL = Transmitters 10dB below full power.
3. **Transmit ON/OFF Switch** – Turns the transmitters on or off.
4. **I/C Select Switch** – Set to the appropriate 2-wire intercom type being interfaced to the unit. Set to either Telex, RTS, or Clear-Com.
5. **Base Station Link Jack** – When two base stations are connected through this jack, it allows wireless talk around (WTA) from the beltpacks to be routed from the system with its transmitters off to the system with its transmitters on.
6. **Relay Contact** – A dry contact closure which is activated when a beltpack user presses the stage announce (SA) button. Normally Open (NO). 1 Amp at 24V maximum.
7. **Intercom A** – Interface to wired intercom system A.  
2-Wire – Male and female 3-pin XLR connectors wired in parallel. The connectors are switched to the appropriate intercom configuration via the I/C Select Switch.  
4-Wire – An RJ-11 type jack compatible with Matrix type intercom systems.
8. **Intercom B** – Interface to wired intercom system B.  
2-Wire – Male and female 3-pin XLR connectors wired in parallel. The connectors are switched to the appropriate intercom configuration via the I/C Select Switch.
9. **Auxiliary Input/Output** – One 3-pin female XLR input connector and one 3-pin male XLR output connector.
10. **Stage Announce Output** – Passes the audio from any of the base stations's beltpack that have selected stage announce (SA).
11. **Power** – IEC receptacle. Accepts 100–240 VAC, 50–60 Hz.
12. **Transmit Antenna** – Female TNC Connector. Color band on antenna must match color dot on base station.

---

**WARNING:** Excessive current through the loop thru ports will damage the intercom! Do not exceed 200 mA current in the 2-wire loop thru circuits.

---



---

**WARNING:** Excessive current through the loop thru ports will damage the intercom! Do not exceed 200 mA current in the 2-wire loop thru circuits.

---

4-Wire – An RJ-11 type jack compatible with Matrix type intercom systems.



**BTR-800 Specifications**

<b>Overall</b>	
RF Frequency Range	Internally Adjustable (2 Vrms typical at rated deviation into 600Ω)
TX Range	Stage Announce Relay
482-608 MHz in 18 MHz TX bands	Dry contact, rated at 1 Amp, 24V Max
US/Canada RX Range	Microphone input sensitivity
572-608 MHz in 18 MHz RX bands	9mV
653-663 MHz for 3 band	Local Headset Output
470-488 MHz for 88 band	40mW output into 600Ω (1% Distortion)
Rest of the World RX Range	<b>Transmitter</b>
572-608, 614-722 MHz in 18 MHz RX bands	Type
Power Requirements	Two Synthesized Transmitters
100-240 VAC, 50-60 Hz, IEC receptacle	Transmit Power (each transmitter)
Temperature Range	100 mW Max (High), 10 mW (Normal)
-4° F - 130° F (-20° C to 55° C)	Modulation Type
Dimensions	FM
19.00" W x 1.72" H x 14.00" D	Deviation
(48.3 cm x 4.4 cm x 35.6 cm)	40 kHz
Weight	RF Frequency Stability
7 lbs x2 oz (3.24 kg)	0.005%
TX Antenna	Modulation Limiter
1/2 Wave (supplied), TNC Male Connector	Peak-Responding Compressor
RX Antenna	Radiated Harmonics & Spurious
1/2 Wave (supplied), TNC Male Connector	Exceeds FCC specifications
FCC ID	<b>Receiver</b>
B5DM529	Type
B5DM514	Dual Conversion Superheterodyne, four Independent Synthesized IFs, FM
Frequency Response	RF Sensitivity
300 Hz - 8 kHz	<0.8 μV for 12 dB SINAD
Four Wire Input	Squelch Threshold
Level Adjustable (2 Vrms typical)	20 dB SINAD
Four Wire Output	IF Selectivity
Level Adjustable (2 Vrms typical)	3 dB at 230 kHz
Telex Intercom	Image Rejection
Input/Output Level Adjustable (1 Vrms typical), Line Impedance 300Ω	70 dB or better
RTS Intercom	Squelch Quieting
Input/Output Level Adjustable (0.775 Vrms typical), Line Impedance 200Ω	90 dB
Clear-Com Intercom	RF Frequency Stability
Input/Output Level Adjustable (1 Vrms typical), Line Impedance 200Ω	0.005%
Auxiliary Input	Distortion
Adjustable (2 Vrms typical)	<1% at full deviation
Auxiliary Output	
Adjustable (2 Vrms typical into 600Ω)	
Stage Announce Output	



*TR-800 Beltpack*

## Controls and Connections – Top Panel

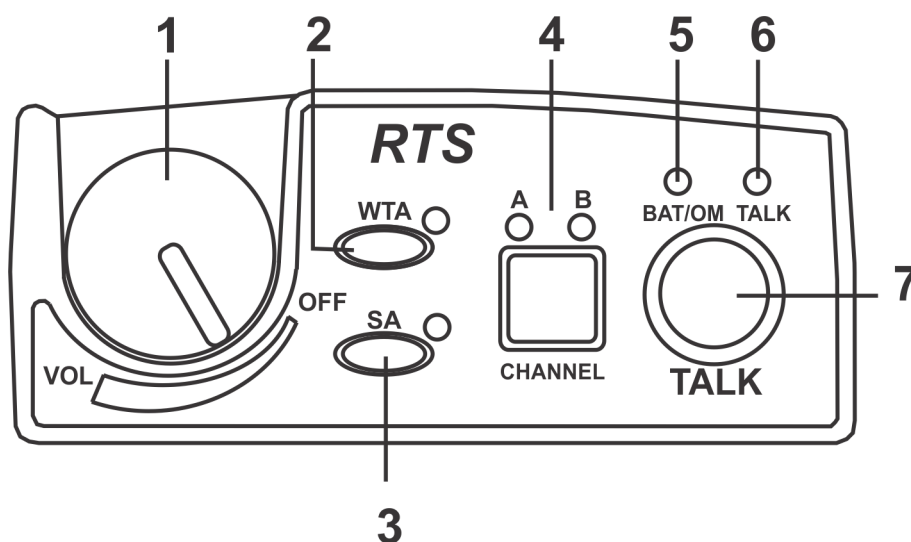
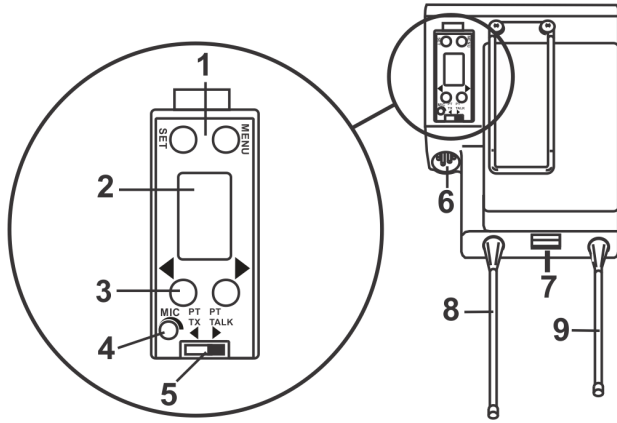


FIGURE 4.  
TR-800 Top Panel

1. **On/Off & Volume Control** – Turns the beltpack power on and controls headset volume.
2. **Wireless Talk Around (WTA)** – When pressed, the user's audio is disconnected from the wired intercom, auxiliary input/output and the base station's local headset. Other beltpack users, on that audio channel, can hear the user as normal. The button activates the nearby red LED as well as the Talk LED, #6, when pressed.
3. **Stage Announce (SA)** – When pressed, the user's audio is routed to the stage announce connector on the back of the base station. The user also loses their sidetone as an indication that stage announce is activated. The other wireless beltpacks and wired users do not hear the user's audio. The button is non-latching and activates the nearby red LED as well as the TALK LED, #6, when pressed.
4. **Audio Channel Selection Button** – Allows user to select either audio channel A or B.
5. **Bat/Overmod Light (BAT/OM)** – Light will flash once when unit is turned on if the battery is good. If the light stays on, battery is low. If the light does not flash, battery is dead. A normal microphone gain setting will cause the LED to flash at the beginning of most words at normal speech levels. If the gain is too high, the LED will be red during the complete word at normal speech levels.
6. **Talk Light** – LED is on when the talk button, SA or WTA is active.
7. **Talk Button** – Press to enable the audio path from the local headset microphone. The TALK LED, #6, will turn red when enabled. A quick press and release latches the talk function, unless latching has been disabled. Holding the button for over 1/2 a second will cause the audio path to be enabled only for as long as the button is held. If the talk function is latched on, pressing the talk button again will turn it off.

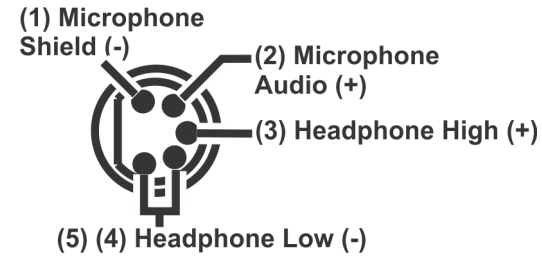
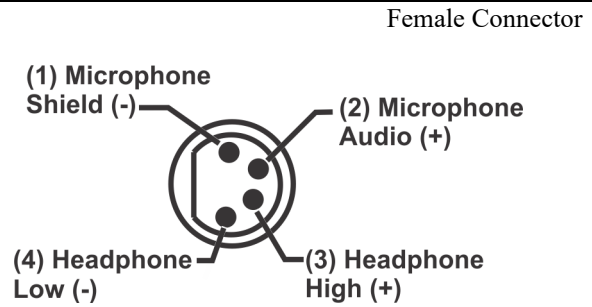
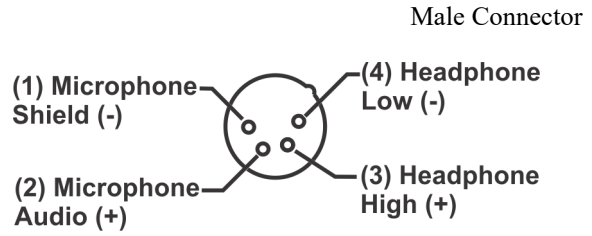


**FIGURE 5.**  
**TR-800 Rear Panel/Connector/Antennas**

1. **[MENU] and [SET] buttons** – Used to select menus and set option on the LCD
2. **LCD (Liquid Crystal Display)**
3. **[UP] and [DOWN] buttons** – Used to select beltpack options on the LCD.
4. **Microphone Gain** – Adjusts the headset’s microphone gain. Adjust so that the BAT/OM LED will flash at the beginning of most words at normal speech levels.
5. **Push-to-Talk/ Push-to-Transmit Switch** –  
Push-to-Talk (PT TALK) – The transmitter is always on. No audio set unless the talk switch, WTA or SA button pressed. Recommended position.

Push-to-Transmit (PT TX) – The transmitter and audio path are off except when the talk switch, WTA or SA, button is pressed.

6. **Headset Connector** – Male XLR connector or female XLR connector. A dynamic or electret headset microphone is automatically detected by the beltpack and a bias voltage supplied, if needed.



**FIGURE 6.**  
**Headset Jack Wiring**

7. **Battery Latch** – Press down to enable the battery pack to be released. While the latch is held down, slide the battery pack about 1/8 inch back, toward the latch, until it stops. Then lift it out.
8. **Receive Antenna** – Screw type 1/4-wave replaceable antenna. The color dot on the screw end of the antenna must match color dot on antenna receptacle.
9. **Transmit Antenna** – Screw type 1/4-wave replaceable antenna. The color dot on the screw end of the antenna must match color dot on antenna receptacle.

**TR-800 Specifications**

## RF Frequency Range

## US/Canada TX Range

572-608 MHz in 18 MHz TX bands  
 653-663 MHz for 3 bands  
 470-488 MHz for 88 band

## Rest of World TX Range

572-608, 614-722 MHz in 18 MHz TX bands

## RX Range

482-608 MHz in 18 MHz RX bands

## Power Requirements

6 AA Cells Alkaline (NiMH optional)

## Current Draw

140 mA (Push-to-Talk, Talk On)

## Temperature Range

-4° F to 130° F (-20° C to 55° C)

## Dimensions

3.75" W x 5.05" H x 1.65" D  
 (9.5 cm x 12.8 cm x 4.2 cm)

## Weight

16 oz (454 g) with alkaline batteries

## TX Antenna

1/4 Wave (supplied), Screw type, Replaceable

## RX Antenna

1/4 Wave (supplied), Screw type, Replaceable

## FCC ID

B5DM518  
 B5DM515  
 B5DM536

## Frequency Response

300 Hz - 8 kHz

## Microphone input sensitivity

7 mV

## Local Headset Output

40 mW output into 600Ω (1% distortion)

## RF Frequency Stability

0.005%

## Modulation Limiter

Peak-Responding Compressor

## Radiated Harmonics &amp; Spurious

Exceeds FCC specifications

**Receiver**

## Type

Dual Conversion Superheterodyne, Synthesized, FM

## RF Sensitivity

<0.7 μV for 12 dB SINAD

## Squelch Threshold

20 dB SINAD (about 1.0 μV)

## IF Selectivity

3 dB at 230 kHz

## Image Rejection

70 dB or better

## Squelch Quieting

90 dB

## RF Frequency Stability

0.005%

## Distortion

<1% at full deviation

**Transmitter**

## Type

Synthesized

## Transmit Power

50 mW Max (auto-power reduction)  
 20 mW Max in US 3 Band, 653-663 MHz, auto-power reduction

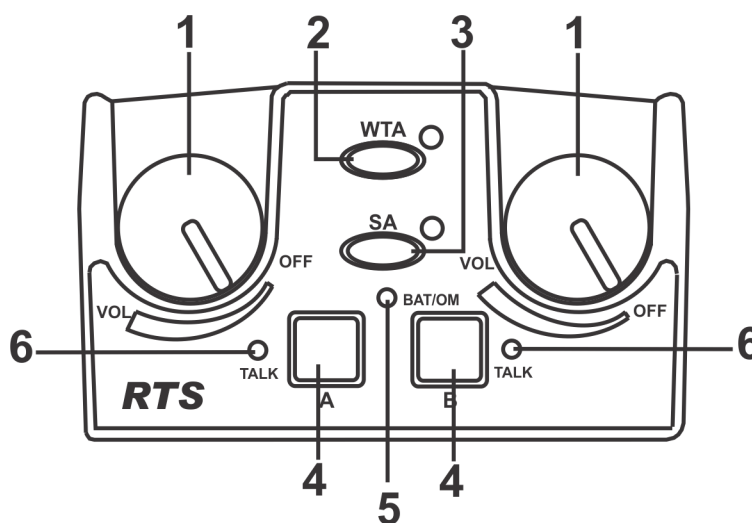
## Modulation Type

FM

## Deviation

40 kHz



**Controls and Connections – Top Panel**

**FIGURE 7.**  
**TR-825 Top Panel**

- 1. On/Off and Volume Control** – Turns beltpack power on and controls headset volume for Intercom Channels A and B. Either knob, A or B, turns the beltpack on. Both knobs must be off to turn the beltpack off. If only one knob is off, then only that Intercom Channel, A or B, is off for both transmit and receive audio.
- 2. Wireless Talk Around (WTA)** – When pressed, the user's audio is disconnected from the wired intercom, auxiliary input/output and the base stations's local headset. Other beltpack users, on that audio channel, can hear the user as normal. The default setting is software selectable, as to which Intercom Channel, A, B, A+B, or currently selected channel, is activated along with the WTA button. The WTA button activates the nearby red LED as well as the software selected Intercom Channel TALK LED if not already active.
- 3. Stage Announce (SA)** – When pressed, the user's audio is routed to the stage announce connector on the back of the base station. The user also loses their sidetone as an indication that stage announce is activated. The other wireless beltpacks and wired users do not hear the user's audio. The button is non-latching and activates the nearby red LED.
- 4. Talk Button** – Press to enable the audio path to either Intercom Channel A or B or A+B, from the local headset microphone. The associated TALK LED, #6, will turn red when enabled. A quick press and release latches the talk function, unless latching has been disabled. Holding the button for over 1/2 second, will cause the audio path to be enabled only for as long as the button is held. If the talk function is latched on, pressing the talk button again will turn it off.
- 5. Low Battery/Overmodulation (BAT/OM) Light** – Light will flash once when unit is turned on if the battery is good. If the light stays on, battery is low, If the light does not flash, battery is dead. A normal microphone gain setting will cause the LED to flash at the beginning of most words at normal speech levels. If the gain is too high, the LED will be red during the complete word at normal speech levels.
- 6. Talk Light** – Will turn red when enabled by associated TALK or WTA button.

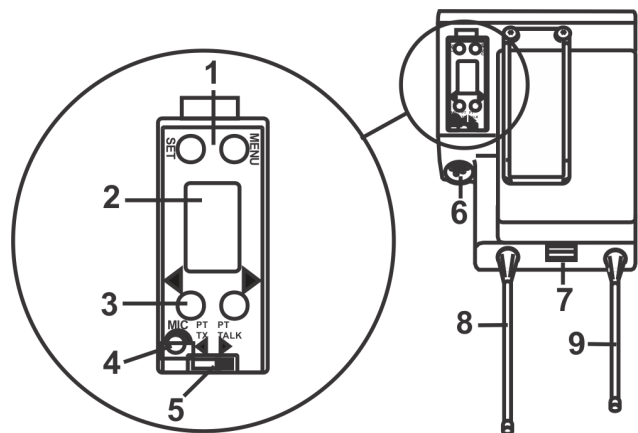


FIGURE 8.

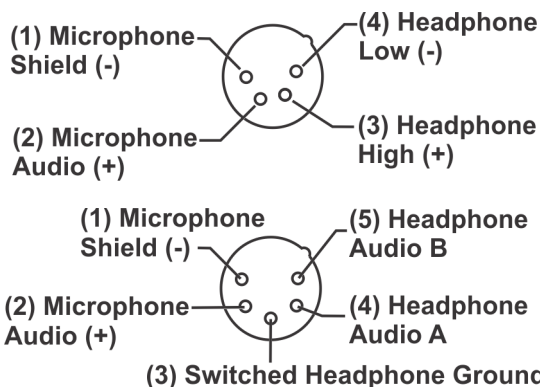
**TR-825 Rear Panel/Connector/Antennas**

1. **[MENU] and [SET] buttons** – Used to select menus and set options on the LCD.
2. **LCD (Liquid Crystal Display)**
3. **[UP] and [DOWN] buttons** – Used to select beltpack options on the LCD.
4. **Microphone Gain** – Adjusts the headset’s microphone gain. Adjust so that the BAT/OM LED will flash at the beginning of most words at normal speech levels.
5. **Push-to-Talk/Transmit Switch** – Push-to-Talk (PT TALK) - The transmitter is always on. No audio sent unless the talk switch, WTA, or SA button pressed. Recommended position.  
  
Push-to-Transmit (PT TX) –The transmitter and audio path are off except when the talk switch, WTA, or SA button is pressed.
6. **Headset Connector** – Male XLR connector or female XLR connector. A dynamic or electret headset microphone is automatically detected by the beltpack and a bias voltage supplied, if needed. Four-pin units are monaural. Five pin units have a software setup which ground or opens pin 3.

**RESULT ON 5-PIN DUAL HEADPHONE**

Menu Set	PIN 3	RESULT ON 5-PIN DUAL HEADPHONE
[ Ab SEP ]	GND	A in one side, B in other side
[ Ab Add ]	OPEN	A + B

**Male Connector**



**Female Connector**

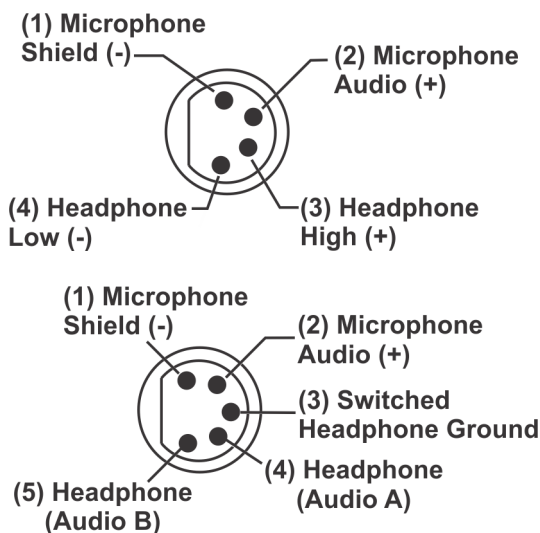


FIGURE 9.  
**Headset Jack Wiring**

Single-sided 5-pin headsets will only receive A or B, depending on how headphone is wired. These headsets must have the beltpack set for [Ab SEP]

7. **Battery Latch** – Press down to enable the battery pack to be released. While the latch is held down, slide the battery pack about 1/8-inch back, toward the latch, until it stops. Then lift out.
8. **Receive Antenna** – Screw type 1/4-wave replaceable antenna. The color dot on the screw end of the antenna must match color dot on antenna receptacle.
9. **Transmit Antenna** – Screw type 1/4-wave replaceable antenna. The color dot on the screw end of the antenna must match color dot on antenna receptacle.



**TR-825 Specifications**

## RF Frequency Range

## US/Canada TX Range

572-608 MHz in 18 MHz TX bands

653-663 MHz for 3 band

470-488 MHz for 88 band

## TX Range (rest of the world)

572-608, 614-722 MHz in 18 MHz TX bands

## RX Range

482-608 MHz in 18 MHz RX bands

## Power Requirements

6 AA Cells Alkaline (NiMH optional)

## Current Draw

190 mA (Push-to-Talk, A and B Talk On)

## Temperature Range

-4° F to 130° F (-20° C to 55° C)

## Dimensions

3.75" W x 5.35" H x 2.02" D

(9.5 cm x 13.5 cm x 5.1 cm)

## Weight

21 oz (595 g) with alkaline batteries

## TX Antenna

1/4 Wave (supplied), Screw type, Replaceable

## RX Antenna

1/4 Wave (supplied), Screw type, Replaceable

## FCC ID

B5DM517

B5DM537

## Frequency Response

300 Hz - 8 kHz

## Microphone input sensitivity

7 mV

## Local Headset Output

40 mW output into 600Ω (1% distortion)

## RF Frequency Stability

0.005%

## Modulation Limiter

Peak-Responding Compressor

## Radiated Harmonics &amp; Spurious

Exceeds FCC specifications

**Receiver**

## Type

Two, Dual Conversion Superheterodyne,  
Synthesized, FM

## RF Sensitivity

<0.8  $\mu$ V for 12 dB SINAD

## Squelch Threshold

20 dB SINAD (about 1.0  $\mu$ V)

## IF Selectivity

3 dB at 230 kHz

## Image Rejection

70 dB or better

## Squelch Quieting

90 dB

## RF Frequency Stability

0.005%

## Distortion

&lt;1% at full deviation

**Transmitter**

## Type

Synthesized

## Transmit Power

50 mW Max (auto-power reduction)

20 mW Max in US 3 Band, 653-663 MHz, (auto-  
power reduction)

## Modulation Type

FM

## Deviation

40 kHz



*Initial Equipment Setup***Unpacking**

Unpacking your RTS System. Below are the items that should come with your base station and each beltback.

Contact the shipper or your dealer immediately if anything is damaged or missing. Fill out the registration card and return it to Bosch to register the unit.

**BTR-800**

Quantity	Description
1	BTR-800 Base Station
1	Power Cord
2	Antennas (one Transmit and one Receive)
1	Warranty and Website Information Sheet
1	Screwdriver
1	2 terminal plug (for SA Relay)
1	Warning Card
4	Rubber Feet
1	Packing Checklist
1	Simplified Declaration of Conformity

**TR-800, TR-825**

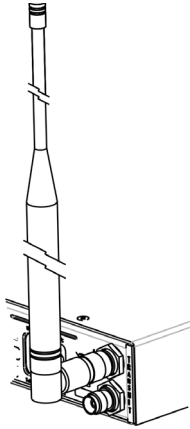
Quantity	Description
1	TR-8XX with Antennas
1	Battery pack
1	Instruction Sheet
1	Screwdriver
1	Warranty and Website Information Sheet
1	Packing Checklist
1	Simplified Declaration of Conformity for Non-US/Canada Units

## Antenna Connection

The base station is supplied with the two antennas. One 1/2-wave antenna for Transmit and one 1/2-wave for Receive. The antennas have TNC male connectors.

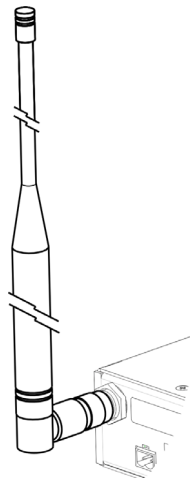
The frequency range of the antennas should match the receiver and transmitter of the base station. Match the color code on the antenna with the color code on the base station.

Attach the transmit 1/2-wave antenna to the antenna input receptacle labeled Transmit on the right side of the rear panel. The antenna should be vertically aligned.



**FIGURE 10.**  
**Attaching Transmit 1/2-Wave Antenna**

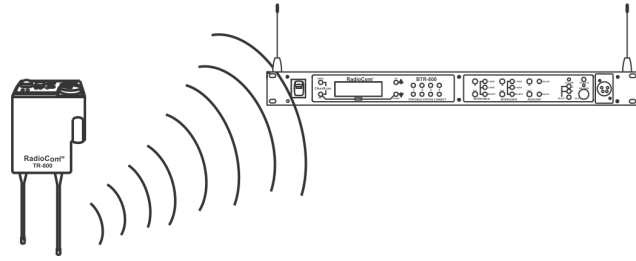
Attach the receive 1/2-wave antenna input receptacle labeled Receive on the left side of the rear panel. The antenna should be vertically aligned.



**FIGURE 11.**  
**Attaching Receive 1/2-Wave Antenna**

## Antenna Polarization

The RTS Wireless Intercom System is Vertically Polarized. This means both the transmitting and receiving antennas should operate in the vertical position.



ANTENNAS SHOULD BE VERTICAL

**FIGURE 12.**  
**Vertically Polarized Antennas**

## Distance between Antennas

The distance between the base station's receive and transmit antennas is not adjustable when the antennas are connected directly on the back of the unit.

The antennas can be removed for better signal path. An RTS coax assembly with remote antennas may be required. See "Accessories and Replacement Parts" on page 83 for ordering information.

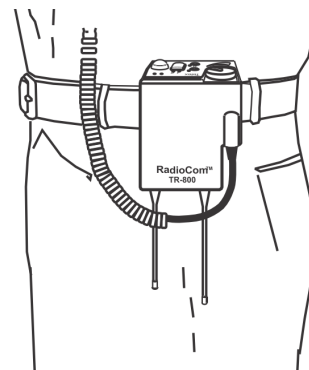
**NOTE:** If your base station is to be located in a shielded rack mount enclosure or other poor RF location, you must remove the 1/2-wave antennas with coax assemblies. See "Accessories and Replacement Parts" on page 83 for remote mounting hardware.

## Antenna Placement

Proper antenna placement probably has the most effect on your RTS Wireless Intercom System's overall performance. The following suggestions will result in optimum performance.

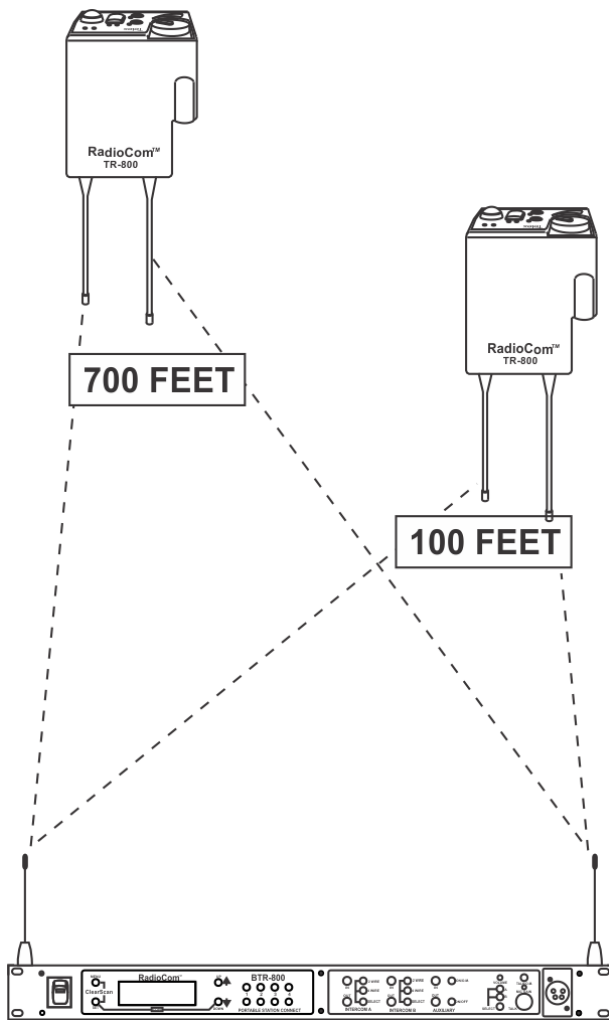
Proper placement of the beltpack can be critical. The antennas should be in the open. Bending the antennas up and placing the beltpack in a pocket, etc., will reduce system distance.

It is suggested that the unit be worn on the belt with both antenna's vertical for best operating range and performance.

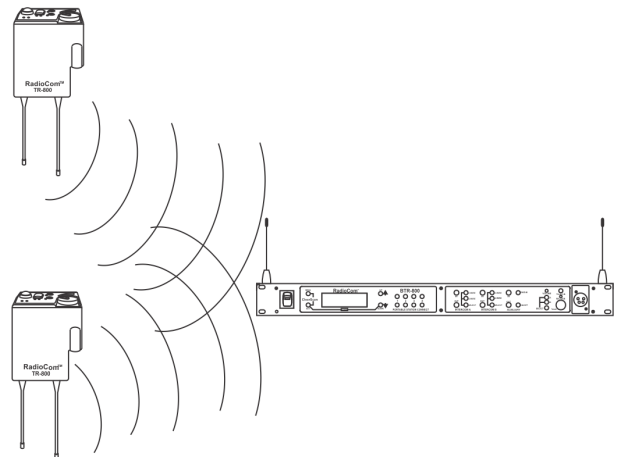


**FIGURE 13.**  
**Proper Dressing of the Antennas**

Keep the distance between the base station and the belt packs as short as possible. The greater the distance, the weaker the signal. Make sure the signal paths between the base station and belt packs are unobstructed. You should be able to visibly locate the base station antennas at all times for best performance.

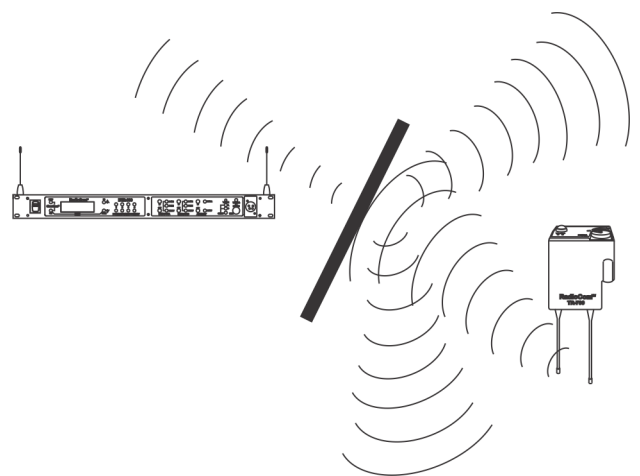


**FIGURE 14. Distance Between base station and belt pack**



**FIGURE 15. Keeping Site Clear to Antenna**

Attempting to operate the wireless intercom system through or around walls, ceilings, metal objects, etc will reduce system range and performance.



**FIGURE 16. Operating System Near Obstructions**

**IMPORTANT:**

Do not mount the base station 1/2-wave antennas on, or next to metal, such as beams, walls with metal studs, equipment racks, etc. This also applies to the antennas when assembled directly to the Base Station. This will detune the antennas which can result in noise or loss of RF signal at the Base Station, see Figure 17.

2. Placing the BTR on top of a shelf or equipment rack unobstructed without remoting the antennas is OK.

1. Placing BTRs in a shelf or equipment rack and using remote antennas is OK.

3. Placing BTRs in a shelf or equipment rack with the antennas mounted on the back of the BTR or the side of the rack is **BAD**.

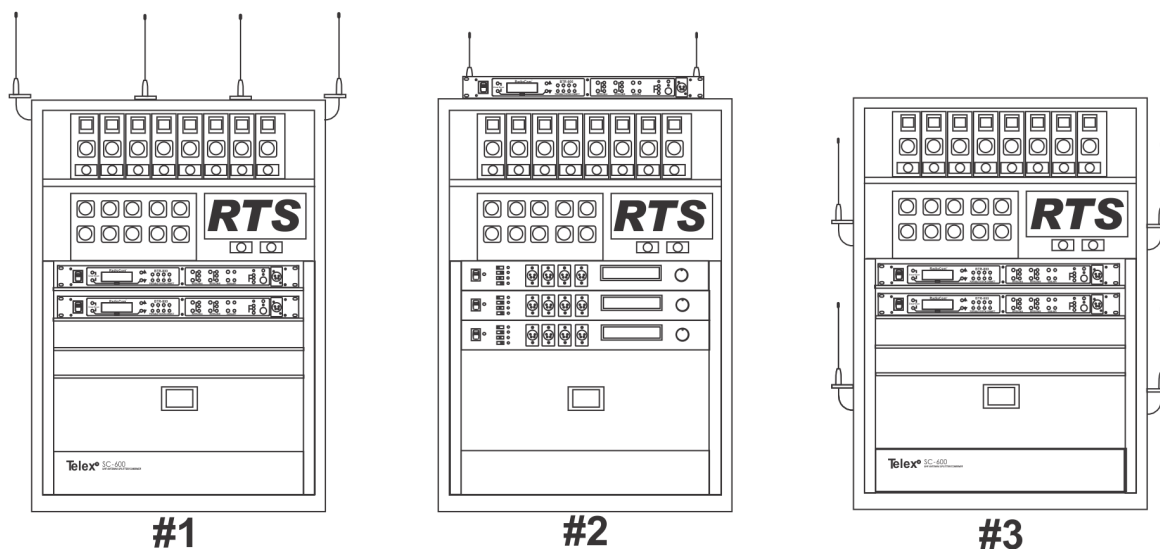


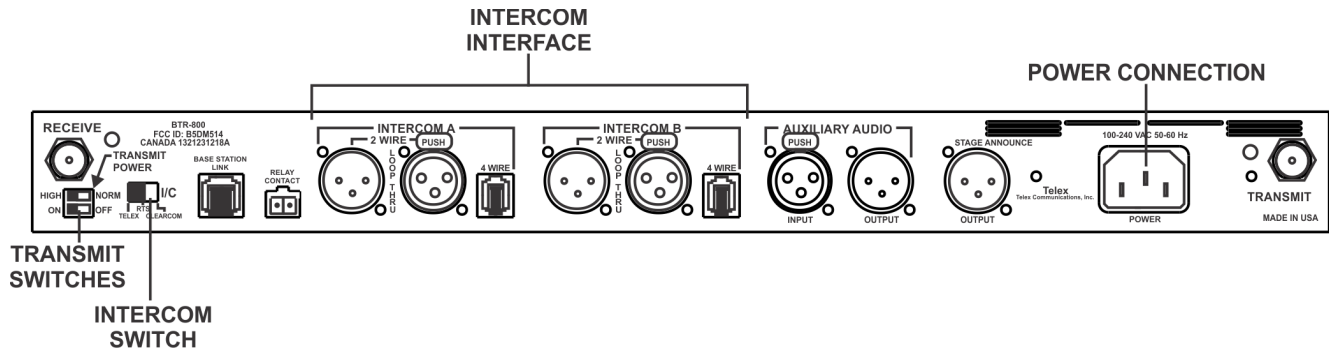
FIGURE 17. Antenna Placement

### Improving Reception and Increasing Range

Keeping the distance from the base station and beltpack as short, and unobstructed as possible will produce the most reliable performance.

The base station is supplied with two antennas. This should provide satisfactory system performance in most applications. System range can be enhanced by remoting the 1/2-wave antennas. The 1/2-wave antennas are ground plane independent, so a ground plane is not required for good performance.

## Base Station Set-up



**FIGURE 18.**  
Base Station – Rear Panel

### Location

Locate the base station with the front and rear of the unit accessible so that switches may be set and connections made. Place the transmit and receive antenna's on the base station. Make sure the color band match the color dot near each antenna. See "Antenna Placement" on page 22 for more information on choosing a proper operating location.

### Power Connection

Plug the supplied power cord into the unit. The base station has an IEC power receptacle that accepts 100-240 VAC, 50-60 Hz. The specific receptacle type is an IEC 60320/C14. The cord it accepts is an IEC 60320/C13. These cords are common and available through many retail hardware/electronic stores if the cord is lost.

### Transmit Switches

There are two switches located on the lower left side of the rear panel. The upper switch sets the transmit power levels to high or normal. The lower switch turns the transmitters on or off.

#### *Transmit Power*

Set the power level to normal if using the beltpacks at close to medium distances (<200 feet, 161m, line-of-sight) from the base station. Set the power level to high if using the beltpacks at a distance (>200 feet, 161m, line-of-sight) from the base station.

#### *On/Off*

Set the transmitter switch to on for normal use. In the off position both base station transmitters are disabled. Setting the switch to off will disable all the beltpacks from hearing anyone else or even their own sidetone.

## Internal Transmit Switches

Internal to the BTR-800 are two transmit switches which enable a user to turn on or off the two transmitters individually. See Figure 19 for the location. The top cover of the base station must be removed for access. The switch closest to the front panel controls transmitter 1 (audio channel A). The switch behind that is transmitter 2 (audio channel B). The default switch position is to the left if you are facing the front of the base station. This is the ON position of the transmitters.

In the normal use of the BTR-800, there is no need to access these switches. They are used to test the transmitters individually at the factory.

## Intercom Switch

The RTS wireless system can be interfaced to RTS, TW, Audiocom (TELEX), Clear-Com, RTS matrix and other intercom (I/C) systems. Set the Intercom switch on the rear of the unit to the appropriate system and connect the system to the base station. The two intercom channels on the rear of the base station have loop-thru male and female XLR connections for two-wire systems and RJ-11 type jacks for four-wire systems.

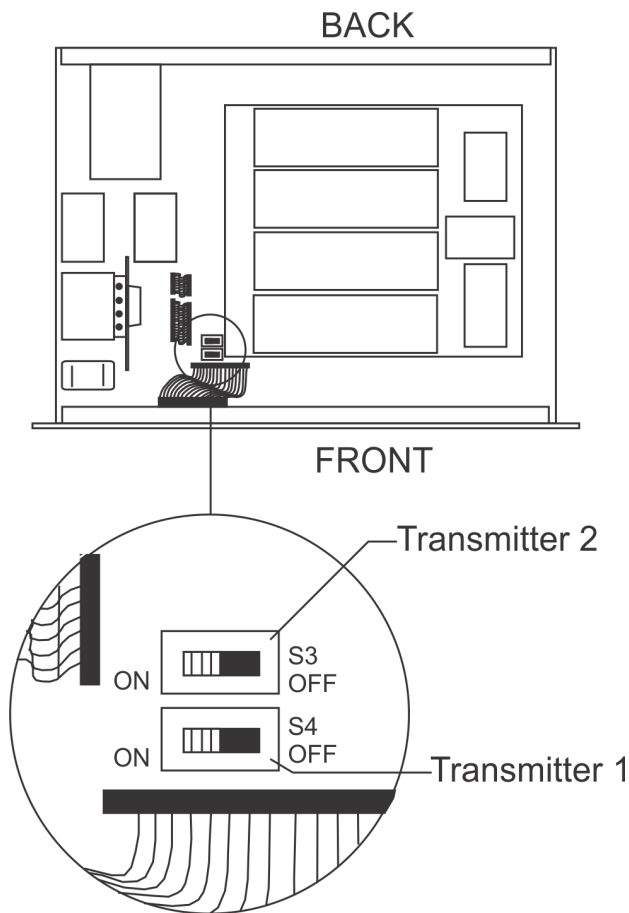
This switch only affects the two-wire intercom systems. The function of the I/C XLRs change depending on the intercom selected. Please see "Intercom Systems Specifications" on page 81 for pinout information of the different two-wire intercom systems.

## Intercom Interface

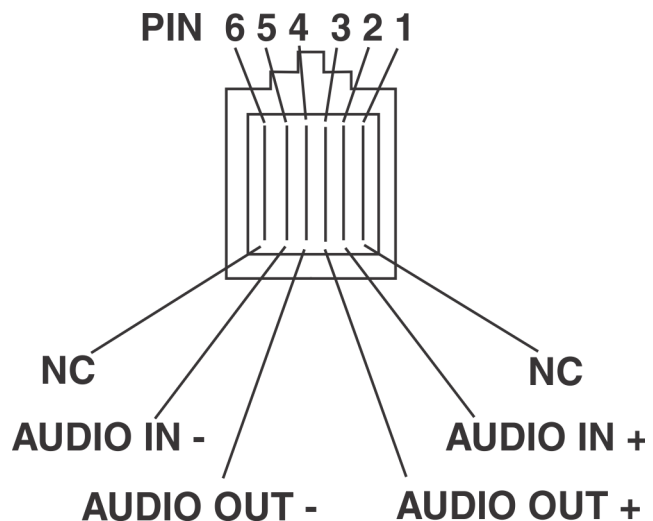
Audiocom (TELEX) and ClearCom intercom systems require one cable for intercom A and one cable for intercom B in order to interface two channels of intercom to the base station. This interfacing is done through the I/C A and B 3-pin XLR connectors on the rear of the unit.

RTS TW intercoms only need to connect one 3-pin cable to one of the four intercom XLR connectors since two channels of audio are carried on one cable. The intercom switch parallels the four XLR connectors when in RTS mode. RTS channel 1 is placed on intercom A and RTS channel 2 is placed on intercom B as long as the RTS TW input to the base station is wired as in "Intercom Systems Specifications" on page 81.

Four-wire intercom systems require one cable for intercom A and one cable for intercom B in order to interface two channels of four-wire intercom to the base station. This interfacing is done through the I/C A and B RJ-11 type jacks on the rear of the unit. See Figure 20 for the pinout of the RJ-11 jacks.

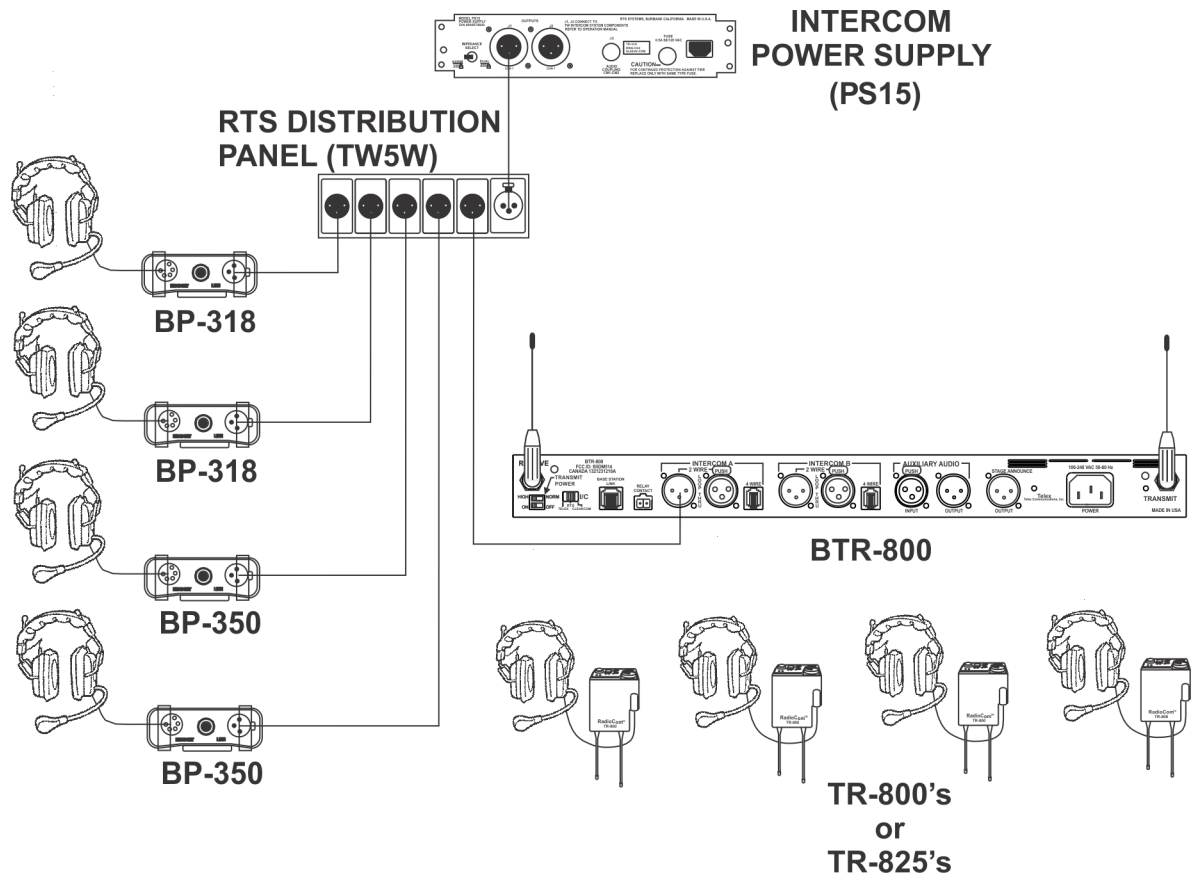


**FIGURE 19.**  
Internal Transmit Switches



**FIGURE 20.**  
RJ-11 Type/Four-wire Pinout





**FIGURE 21.**  
Example Interface to an RTS TW System

### Dual Listen Functionality

The base station's main audio board has the option of placing additional parts to enable dual listen. Dual listen allows the mixing of the intercom channels. The mixing will occur locally, within the base station, and is only heard on that base station's beltpacks. The user will have the ability to enable/disable the mix of I/C A into I/C B or vice versa. If you have TR-825 beltpacks, there is no need to install this base option. The level

of the mix can be controlled at the TR-825 via the two volume controls.

They will also have the ability to control the level of the mix (-4dB to -24dB down from the main channel). Removing two surface mount resistors and installing two SPDT switches and two potentiometer enables dual listen. The parts to be installed are shown in Table 1. The two resistors on the board to be removed are in Table 2.

Board Designator	Description and Function	Value	Manufacturers, Part No.
VR5, VR6	Potentiometers VR5 = Controls I/C A into I/C B Mix VR6 = Controls I/C B into I/C A Mix	20kΩ –25kΩ	Bourns, 3309P-1-203 CTS, U262R253B Piher PT10LV10-203A2020
S6, S7	Switches S6 = Enable/Disable I/C A into I/C B Mix S7 = Enable/Disable I/C B into I/C A Mix	SPDT	E-Switch, 500ASSP1M2RE E-Switch, EG1218 AlcoswitchTSS11DGPC

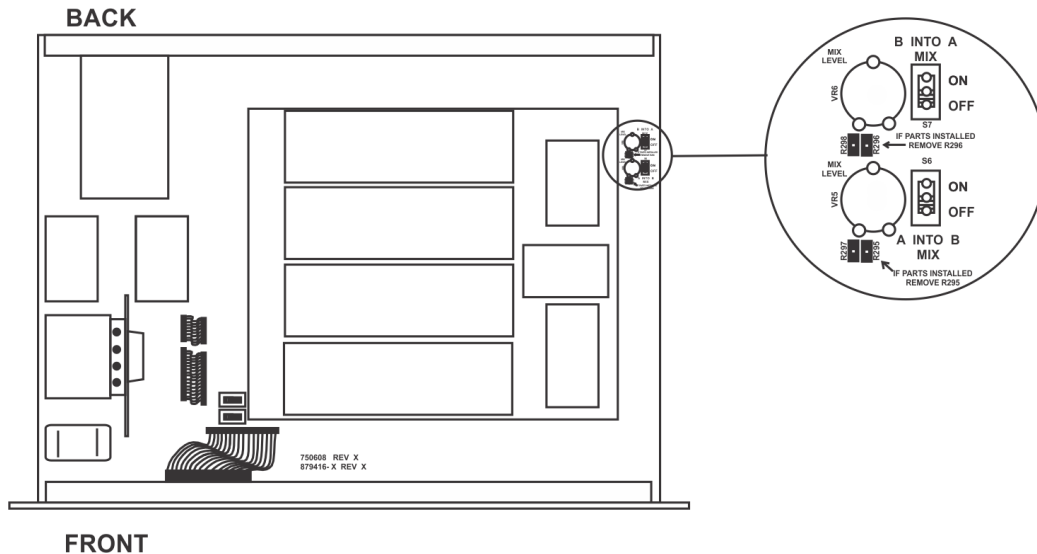
**TABLE 1.**  
**Parts to be installed by User to Enable Dual Listen**

Board Designator	Description and Function	Value
R295	Resistor, Default if mix components not installed	10k
R296	Resistor, Default if mix components not installed	10k

**TABLE 2.**  
**Parts to be Removed by User to Enable Dual Listen**

The listed manufactures and part numbers in Table 1 are those that the audio board was laid out for and thus the hole pattern used. Several of these parts may be found at Digi-Key and other distributors. Trim the leads on the parts so they cannot hit the metal case. Locations to place these components are provided on audio board part number 750608 and ASY000108000.

The audio board part number is located on the lower left hand side of the board if facing the front of the unit. The location where the components can be installed are on the upper right hand side of the board. See Figure 22 for the locations. Board part number 750541 does not have locations to place components, however, modification documents may be obtained from Bosch Security Systems, Inc. for those who wish to modify older audio boards for dual listen.



**FIGURE 22.**  
**Audio Board Part Number and Dual Listen Component Locations**

### Auxiliary Input/Output

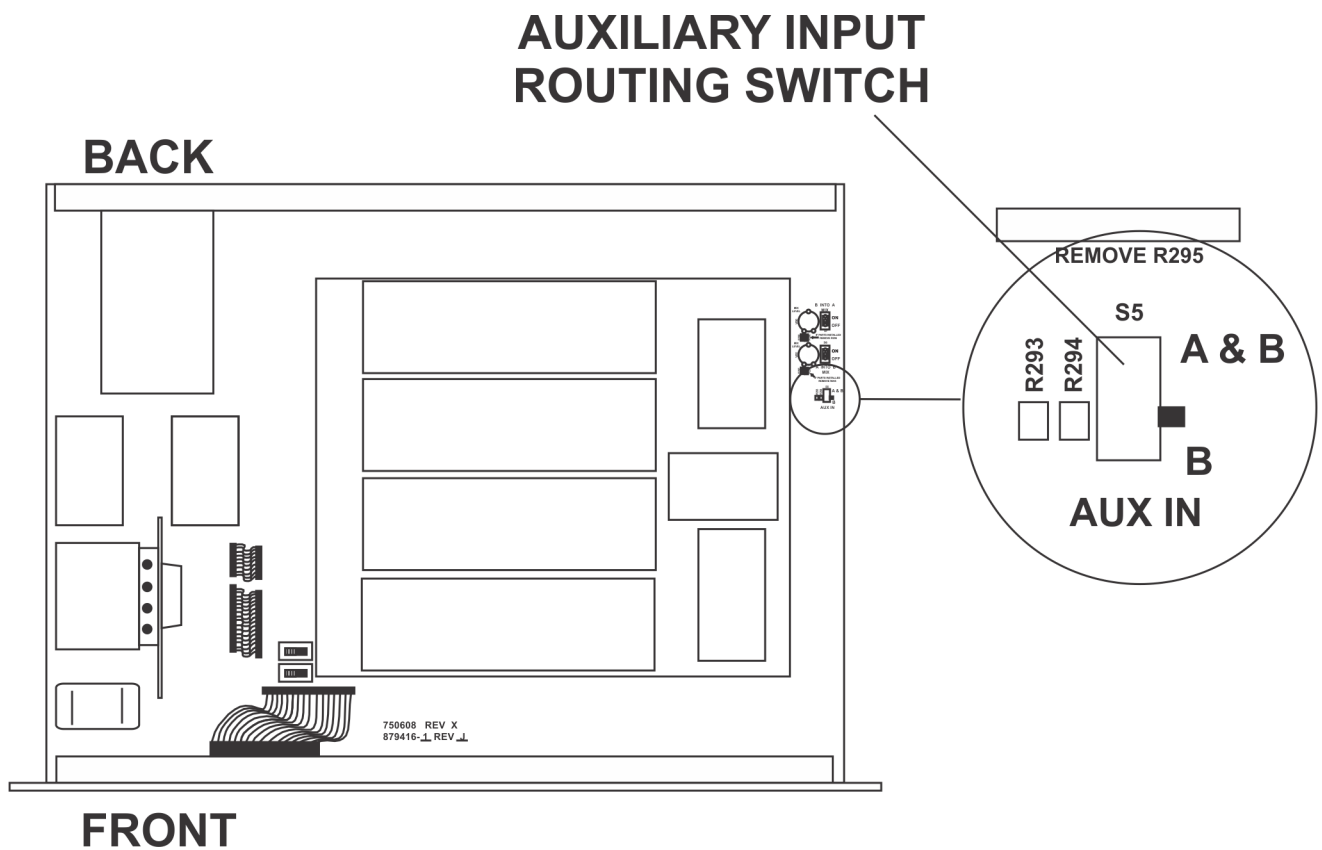
The input and output 3-pin XLR auxiliary connections are for supplying additional balanced audio into and receiving balanced audio from the base station. **The output auxiliary connection only interfaces to intercom B.** However, there is an internal switch to control the routing of the input auxiliary audio. See “Internal Auxiliary Input Routing Switch” on page 29.

**The input and output auxiliary audio is global.** This means the input auxiliary audio is placed on the base local headset, beltpack(s), headsets, and **any wired intercom system interfaced to the base station.** The intercom channel(s) the input auxiliary audio is placed on depends on the position of the input routing switch. The output auxiliary audio is also taken from the intercom B base local headset, beltpack(s), headsets,

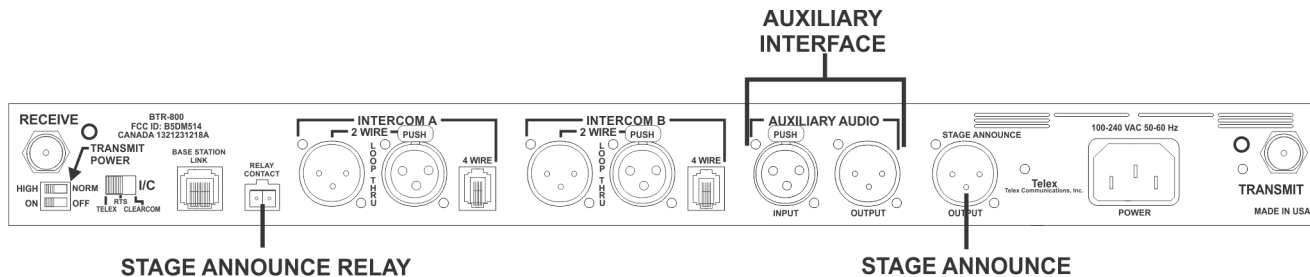
and **any wired intercom connected to the base station.** A modification document is available from Bosch Security System, Inc. for those who wish to modify the base station so that auxiliary input audio is heard only locally; base local headset and beltpack(s) headsets.

### Internal Auxiliary Input Routing Switch

This switch controls the routing of the input auxiliary audio. This switch has two positions. The B position places auxiliary input audio onto intercom B only (default from factory). The A & B position places auxiliary input audio onto intercom A and B. See Figure 23 for the locations of this internal auxiliary input routing switch.



**FIGURE 23.**  
Auxiliary Input Routing Switch

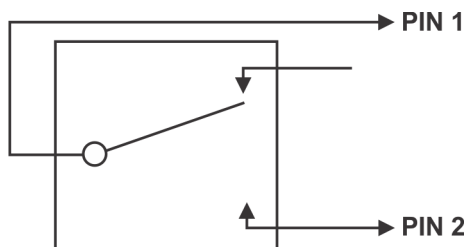


**FIGURE 24.**  
Base Station – Rear Panel

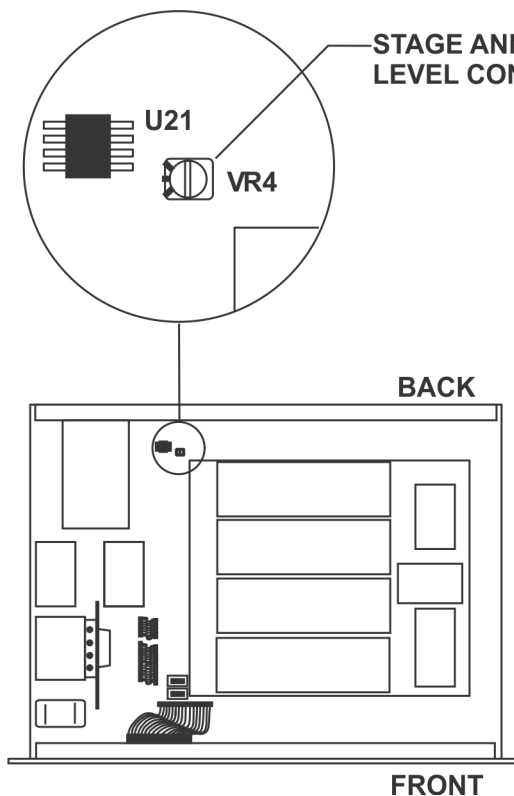
**Stage Announce / Relay Contacts**

The stage announce output connector is where the audio exits the base when any of the beltpacks press the [SA] button. The output is balanced audio through a male 3-pin XLR. The stage announce output level is set at the factory for 2 Vrms typical output at rated deviation into 600 Ohms. This should be adequate for most applications. There is an internal level adjustment for this output too. See Figure 27 for the location of the small level trimmer. The top cover of the base station must be removed for access.

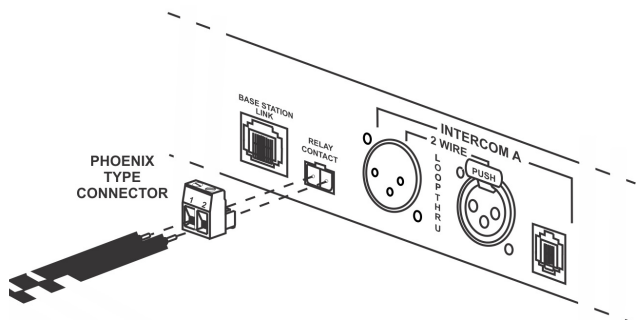
A relay contact closure is also activated when a beltpack user presses the [SA] button. The contacts are normal open (N.O.). Rating: 1 Amp at 24 volts AC/DC maximum. A Phoenix type connector (supplied) plugs into the relay contact port on the rear of the base station. This connector provides a screw-type closure for an easy connection to wires.



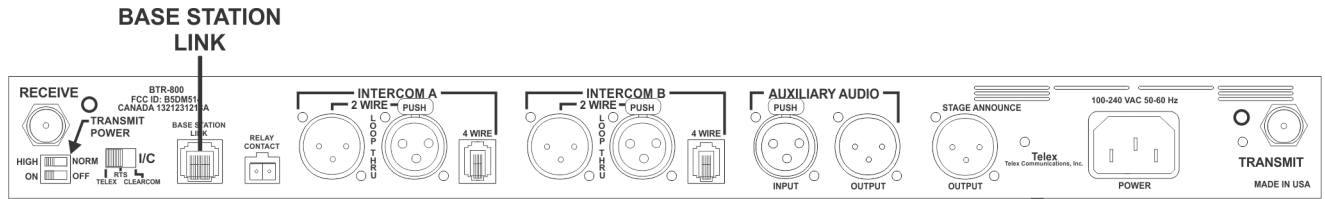
**FIGURE 25.**  
Relay Output Schematic



**FIGURE 27.**  
Internal Stage Announce Level Control



**FIGURE 26.** Relay Contact Jack Adapter (Screw Terminal Adapter)



**FIGURE 28.**  
**Base Station – Rear Panel**

**Base Station Link**

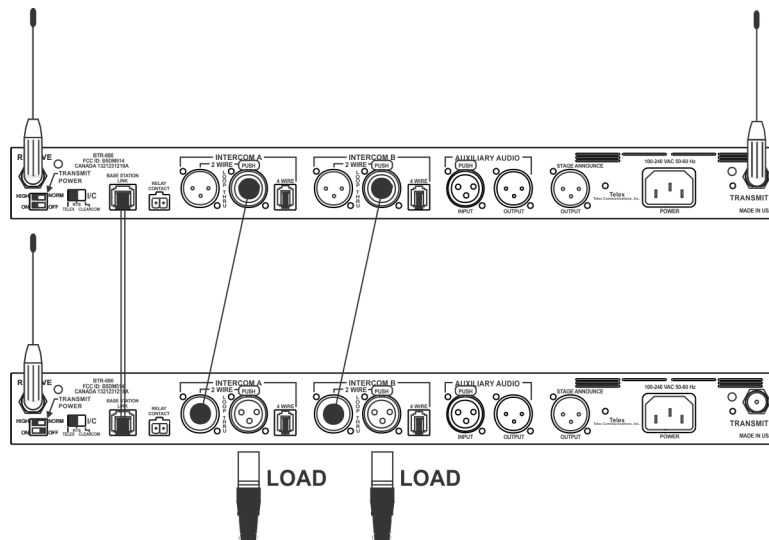
This RJ-45 type jack allows the connection of wireless talk around (WTA) to two base station of the same frequency bands. This allows WTA on I/C channel A and WTA on I/C channel B to be carried through to the other base station attached together via this jack.

WTA channel A and channel B is contained within a base station unless the transmit power is off. If it is off, the WTA audio is routed through the base station link cable to the other base that has its transmitter on.

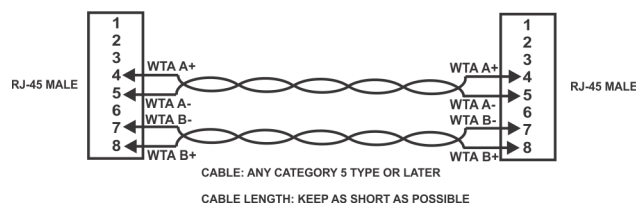
A cable to accomplish this task is NOT supplied, but can easily be made with common category 5 (CAT-5) or later wiring.

In fact, the most common 10BaseT Ethernet patch cables, 568-B wired cables, can be used to connect bases together. The required cable is shown below.

The regular two-wire intercom channels are passed from base to base via the wired intercom cables and do not require the base station link cable.



**FIGURE 29.**  
**Two Stand Alone Base Stations Connected Together**



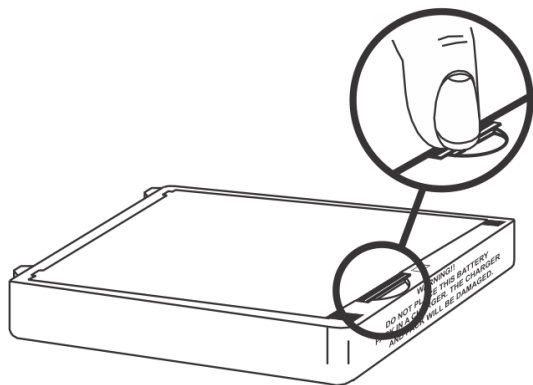
**FIGURE 30.**  
**Base Station Link Cable**

## Beltpack Setup

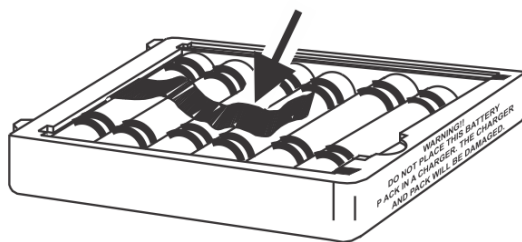
### Battery Installation

Ensure that the On/Off volume control knob is turned off. Press down and hold down the battery release latch, slide the battery pack about 1/8-inch back, toward the latch, until it stops. Then lift the battery pack out. Replace the batteries as follows:

1. Open the battery pack by inserting finger nail and lifting.



2. Pull battery strap to remove low or dead batteries.

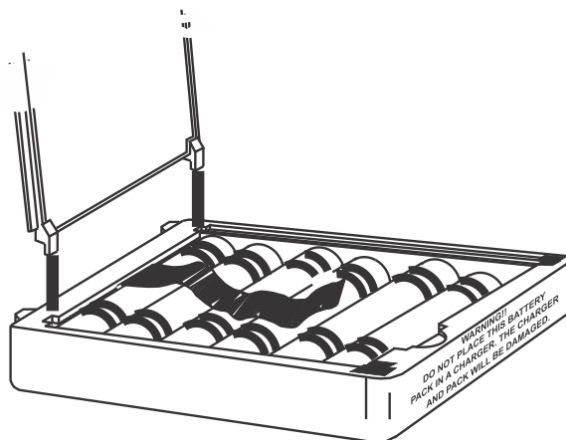


3. Load new batteries following the polarity, as shown in the battery case.



4. Start loading at the end of the case where the strap is attached to the case.
5. Be sure the strap goes under the batteries.

6. Tuck end of strap under door when placing the battery cover back on the case.



**FIGURE 31.**  
Battery Installation

---

**WARNING:** Do not place an alkaline TR battery pack in any battery charger. Severe charger and battery pack damage may result.

---

7. For the TR-825, ensure that both On/Off volume control knobs are turned off prior to inserting the battery pack onto the TR-825 to prevent the possibility of a voltage spike that could the unit to become inoperable.

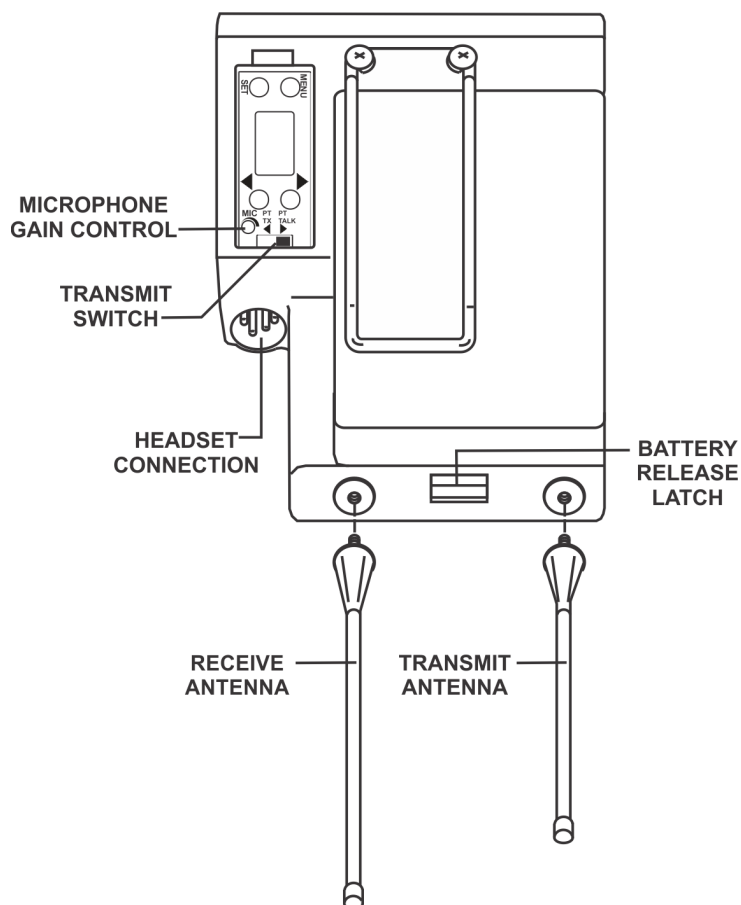


FIGURE 32.

FIGURE 33. TR-800 and TR-825 Rear Panel

### Antenna Connection

The beltpack comes with two detachable, screw-type, 1/4-wave antennas. To attach the two antennas, screw into the receptacles at the bottom of the beltpack. The color dot on the screw end of the antenna must match the color dot on antenna receptacle. The receive antenna screws into the left receptacle if the beltpack is laying flat with the battery compartment face up and the antenna receptacles facing you. The other antenna is the transmit antenna. New antennas can be ordered if desired, see “Accessories and Replacement Parts” on page 83.

### Transmit Mode

The rear panel located transmit switch has the following two modes:

**Push-to-Talk (PT TALK)** – Recommended position - The transmitter is always on. No audio is sent unless the talk switch, WTA or SA button is pressed.

**Push-to-Transmit (PT TX)** –The transmitter and audio path are off except when the talk switch, WTA or SA button is pressed.

### Headset Connection

Insert the headset plug into the XLR connector. See the headset pinout in the TR-800/TR-825 beltpack controls and connections section if this is not a Telex headset. A dynamic or electret headset microphone is automatically detected by the beltpack and a bias voltage supplied, if needed.





## *Pre-Walk-Thru Checklist*

---

Following the instructions fully to this point you have successfully completed the following checklist:



Located the base station properly.



Connected power to base station



Connected the 1/2-wave antennas to the base station. Checked frequency range of the antennas with the frequency of the base station by correctly matching color codes.



Connected 1/4-wave antenna to the beltack. Checked frequency range of the antennas with the frequency of the beltack by correctly matching color codes.



Base station transmit power switches in the correct positions.



Transmit mode switch on beltack set correctly.



Set wired intercom type correctly.



Connected headsets to base stations (if needed) and all beltacks.



Connected the base station to any auxiliary audio, intercom, external P.A. system, or relay contact detect circuit, if needed.



Installed batteries in the beltack.



If you missed any of the above instructions, go back and complete that instruction before going on.



**Frequency Plan Overview**

The BTR/TR-8XX has 36 factory defined frequency groups and 12 user-programmable frequency groups. A **Group** defines the two-base station transmit frequencies and thus the two receive frequencies on all the beltpacks. A **Channel** defines a base station receive frequency and thus a beltpack transmit frequency. A base station receive channel that does not have a frequency set for it will have a dash to the right of it on the Group/Channel select screen. Details on setting frequencies may be found in the BTR 800 Menu Structure on page 40 and TR-8XX Menu Structure on page 49.

**Factory-Defined Groups**

The 36 factory-defined groups were carefully chosen to avoid certain intermod products and various other possible sources of interference. The Groups are set and cannot be changed. There is a limited number of channels which can be chosen from within these groups.

The first 24 factory-defined groups (01A – 12B) are pair groups that can be used for single (up to four beltpacks) and dual (up to eight beltpacks) BTR-800 systems. They are arranged 01A, 01B, 02A, 02B...011B, 12A, 12B. A pair group, like 1A and 1B, have different base station transmit frequencies, however, they both have the same eight base station receive channels from which to choose. Each channel represents a unique frequency. For example, one BTR-800 could be set on Group 02A and channels 01, 02, 03, and 04. The other BTR-800 could set on Group 02B channels 05, 06, 07, and 08. As long as the channels are different, everything should be fine.

The next 12 groups (13–24) are single groups that primarily are used for single (up to four beltpacks) BTR-800 systems. The number of channels from which to choose from in these groups will vary from group to group.

Three band base stations and beltpacks used in the US have a reduced channel map offering due to regulatory changes that reduced the size of the three band. Please see Section 16 for more information.

**User-Programmable Groups**

The 12 user-programmable group are initially empty. The transmit and receive frequencies are fully editable within these groups. In fact, factory-defined groups may be copied to user-programmable groups and then edited, if desired. See the BTR-800 Menu Structure on page 40 and TR-8XX Menu Structure on page 49 for details on how to copy and edit frequencies.

**System Quick Start**

Follow the list below to quickly get a base station and beltpack(s) operating. When completed the user should have a base station and 1 to 4 beltpacks up and running with full operational ability. The base station will be on Group 01A with its four receivers on channels 01, 02, 03, and 04. Each beltpack will be on Group 01A with a unique transmit channel number matching one of the base station receive channels.

1. Plug-in the base station via the supplied power cord and connect the antennas. The color dots on the base should match the color rings on the antennas.
2. Base station rear panel switches: Transmit power set to High and on.
3. Ensure base station rear panel IC switch matches attached wired intercom system. If used stand alone or connected to a 4-wire system then IC switch position is not applicable.
4. Press [MENU] as powering-up the base station. This will place it on group 01A and set the receives on channels: 01, 02, 03, and 04.
5. Place the front panel IC A and IC B IN and OUT level controls in the 12:00 o'clock position. Check that front panel IC A and B is in 2-wired for AudioCom (Telex), RTS-TW and ClearCom wired systems, and 4-wired for RTS Matrix and stand-alone operation.
6. Pace batteries in the beltpacks.
7. Remove the rear switch cover on the beltpacks. Set the beltpack rear panel slide switch to push-to-talk (PT TALK).
8. Press [MENU] as powering-up each beltpack. This will place the beltpack on group 01A with the channel 01 flashing.
9. Use the [UP] and [DOWN] arrow buttons to change the channel to match a channel on the base station. Then press [SET]. If leaving on channel, just press [MENU]. Each beltpack should have a unique channel number.
10. The group/channel on the beltpack should now match the group and receive channel on the base station. Nothing should be flashing on the beltpack screens.
11. Plug headsets into the beltpacks and set the microphone gain so the BAT/OM LED will flash at the beginning of most words at normal speech levels.
12. **DONE.**

## Base Station Operation

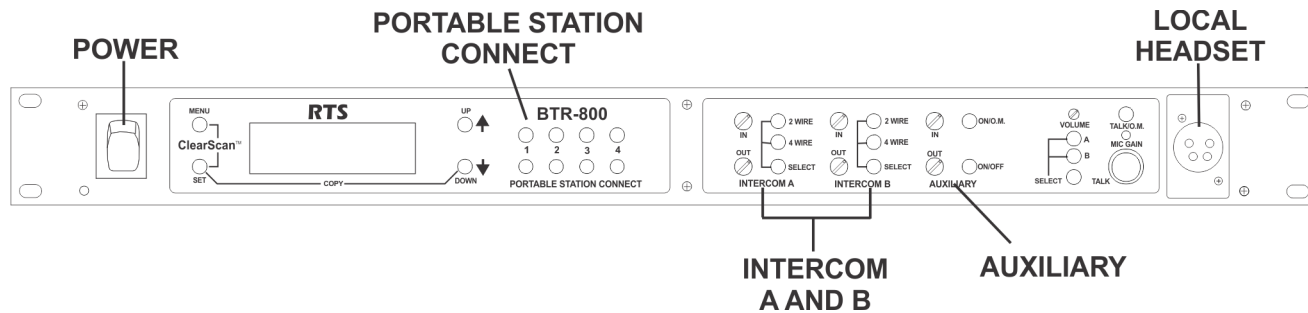


FIGURE 34. Base Station – Rear Panel

### Power

If you have followed the instructions in Section 4, Initial Equipment Setup, you should now be ready to turn the base station on.

Set the base station power switch to the on position, by pushing the top of the switch. The internal cooling fan will start immediately and the LCD display and front panel indicator lights will come on in five or six seconds.

### Local Headset

**Talk Button** – Press to enable the audio path from the local headset. The TALK/O.M. LED will turn green when audio is enabled. A quick press and release latches on the button. If the talk function is latched on, pressing the talk button again will turn it off. If the local headset is not being used, the talk button should be off. This keeps additional noise out of the system.

**Microphone Gain** – Adjusts the headset’s microphone gain. Adjust so the TALK/O.M. LED flashes from green to red on loudest speech.

**Headset Intercom Select Button** – Select the intercom system to connect to the local headset. Each press of the [SELECT] button changes the connection; Channel A, Channel B, and Both. The cycle will then repeat. The LEDs above the [SELECT] button light to indicate the current selection.

**Volume** – Adjust the volume to the headset by rotating the volume control as required for a comfortable listening volume.

### Portable Station Connect

Select the audio paths from the base station’s four receivers that you wish to enable. The corresponding LED above the select button is on when the audio path is enabled. If a belt-pack user has their portable station connect path off at the base, that user will no longer hear their sidetone and their audio will not be passed to anyone. The user will still be able to hear everyone. The selection is retained in non-volatile memory, so it will come up where last left if the unit is power cycled.

Always disable unused audio receive paths. This reduces the chances that external RF noise can get onto the audio buses via an open receiver.

### Intercom A and B

**Intercom Select Button** – Press the [SELECT] button to choose between 2-wire or 4-wire intercom systems. The green

LED will indicate the current mode of the intercom channel. If the base station is connected to a 2-wire system, such as Audiocom (Telex), RTS TW or Clear-Com, set the intercom to 2-wire. If it is connected to a 4-wire system, such as RTS Matrix, set the intercom to 4-wire. It is also possible to have intercom A connected to a 2-wire system and intercom B connected to a 4-wire system or vice versa. The selection is retained in non-volatile memory, so it will come up where last left if the unit is power cycled.

**In Level Control** – Adjusts the audio level of the wired intercom system’s input to the base station.

**Out Level Control** – Adjusts the audio level of the base station’s output to the wired intercom system.

If the base station is used stand-alone, no wired intercom system connected, it must be set in the 4-wire mode. The 2-wire mode requires a wired intercom system or appropriate load be connected to the intercom A or B XLRs. If not loaded, a large gain increase will take place in the unload intercom channel which may be high enough to produce a loud howling sound.

### Auxiliary

**Auxiliary Input Select Button** – Press the [SELECT] button to turn on or off the auxiliary input to the base station. The selection is retained in non-volatile memory, so it will come up where last left if the unit is power cycled.

**In Level Control** – Adjusts the audio level of the wired auxiliary system’s input to the base station.

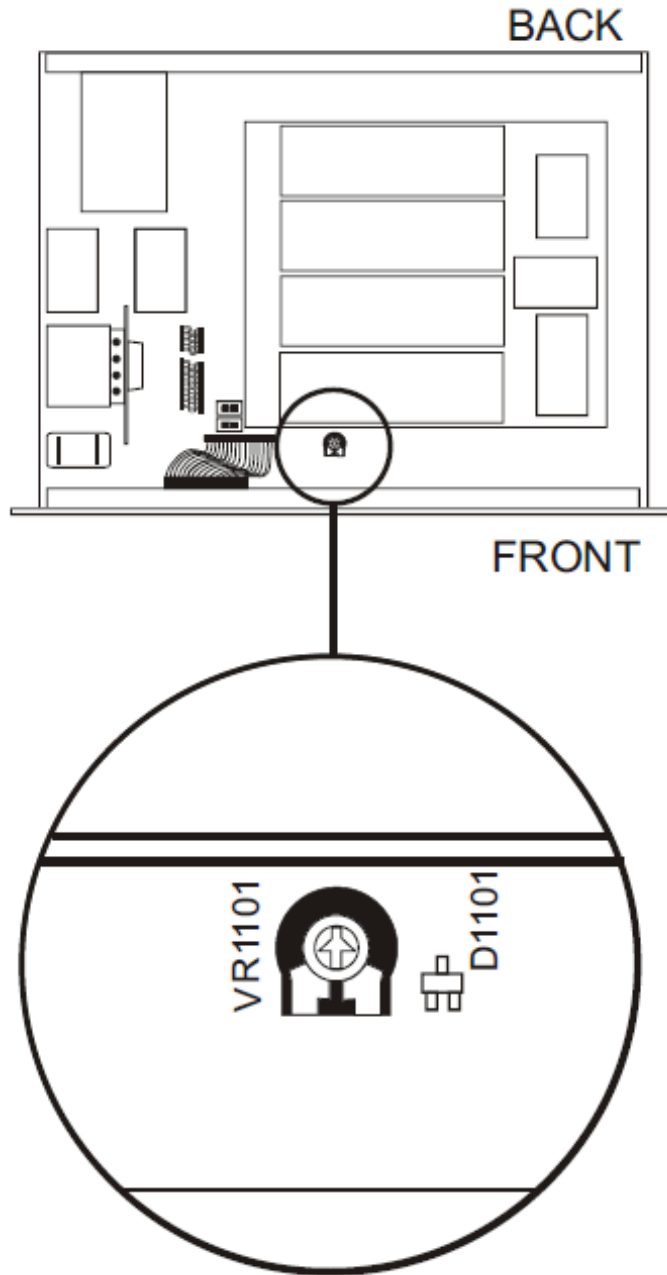
**Out Level Control** – Adjusts the audio level of the base station’s output to the auxiliary XLR plug.

The auxiliary output connects only to intercom B. It does not interface to intercom A. The auxiliary input may be switched to B intercom (default) or A and B intercom. See “Initial Equipment Setup” on page 21 for the location of this internally located input routing switch. The auxiliary output is always available at the back panel output XLR. It cannot be switched on or off like the input. Both the input and output are balanced audio ports. Auxiliary input and output audio is global. See “Initial Equipment Setup” on page 21 for more details.

**Display Contrast**

The LCD's (Liquid Crystal Display) contrast is set from the factory to a standard level. However it is possible for the user to

adjust the contrast, if desired. The contrast control is internal to the BTR-800 unit near the front panel. The cover must be removed for access to this control. See Figure 35.



**FIGURE 35.**  
**LCD Contrast**

BTR-800 Menu Structure

The following contains the base station menu structure and references the pages in which further detail of that menu may be found.

Main Screen Flowchart

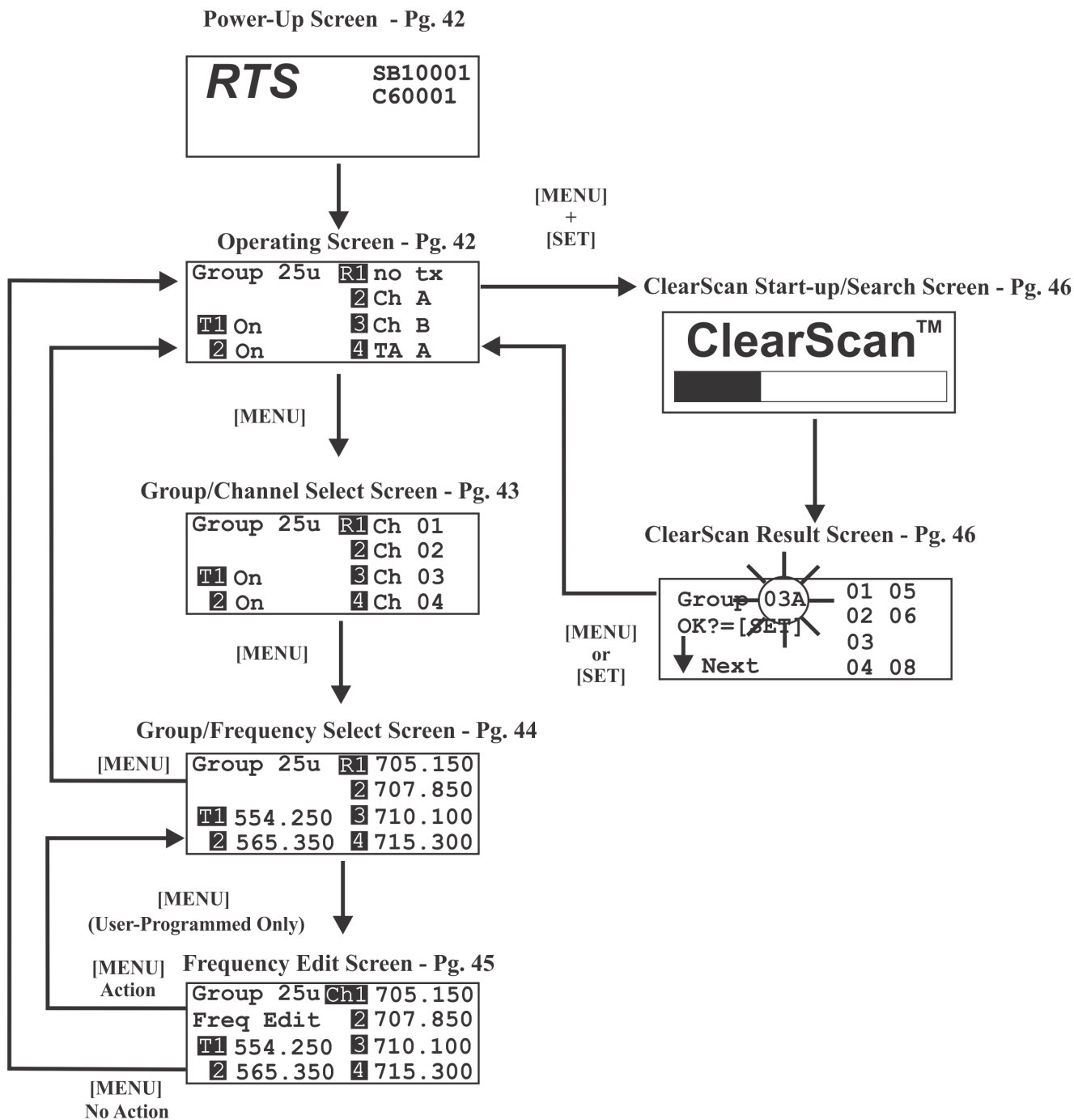


FIGURE 36. Power-Up Screen

Other Special Key Sequences

- Lockout ..... page 47
- Copy..... page 47
- 1st Use Default ..... page 47
- Factory Default ..... page 47

NOTE:

Pressing [MENU] within a screen after action has occurred escapes from that action and places the user at the current screen. Any editing that had been done since [SET] had been pressed is aborted.

## Power-Up Screen

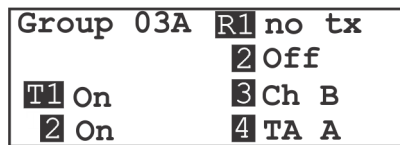
- This screen is displayed only on power up, first use default and factory default.
- The 1st upper right corner number displays the base's software revision. The single version number increments for changes in operation software.
- The 2nd upper right corner number displays the base's channel map (frequency plan) version. The single version number increments for changes in the channel map.
- Once the power-up screen is displayed, it will change to the operating screen after a few seconds.



## Operating Screen

- Screen is displayed after power-up screen.
- System will revert to this screen if no activity is detected on the LCD display buttons after three minutes.
- Screen displays current status of the system.

## Operating Screen



---

**Beltpack Activity Code Definitions**

no tx	No beltpack transmit carrier detected
Off	Receiver is not selected on front panel
Ch A	Beltpack audio is on Channel A
Ch B	Beltpack audio is on Channel B
Ch A&B	Beltpack audio is on Channel A and B (TR-825 only)
TA A	Beltpack Channel A Talk Around Active
TA B	Beltpack Channel B Talk Around Active
TA A&B	Beltpack Channel A and B Talk Around Active (TR-825 only)
SA	Beltpack Stage Announce Active

**NOTE:** Older versions of BTR-800 software do not support the detection of TR-825 Ch A&B and TA A&B control tones.

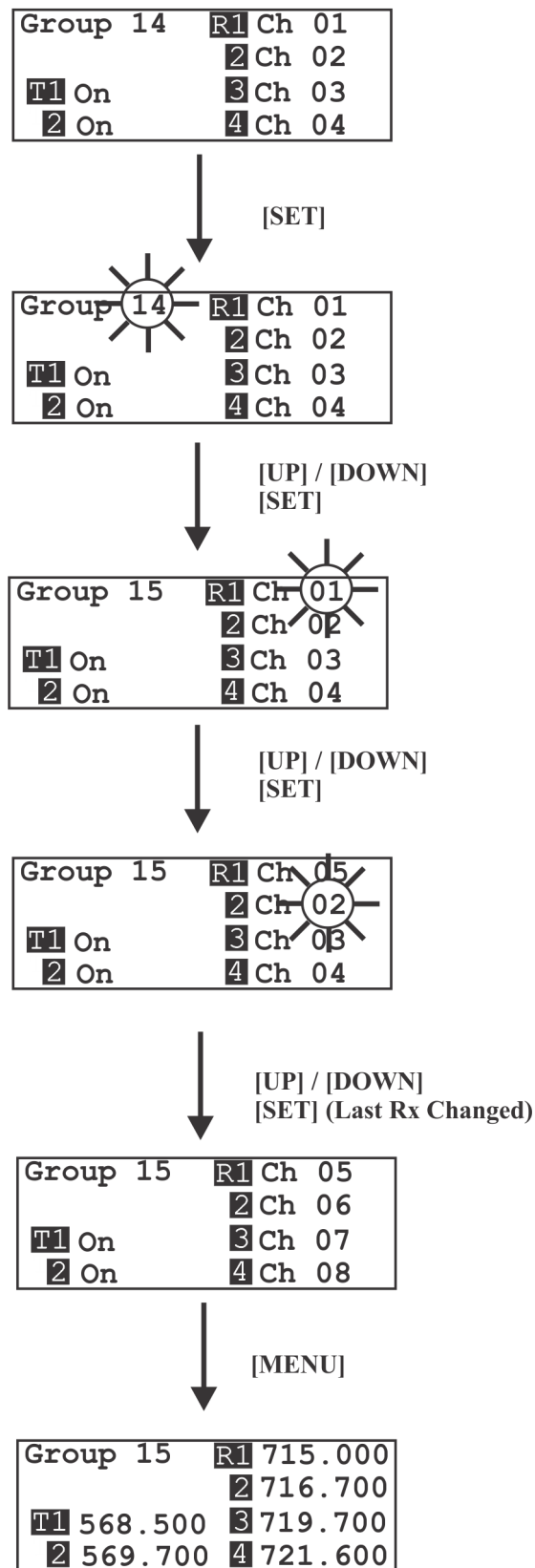


### Group/Channel Select

The Group/Channel select screen allows the user to change the group and select from a pre-determined number of channels on each receiver.

- Press [MENU] once to enter the Group/Channel Select Screen from the operating screen.
- Press [SET] to enter group edit. The group number will start flashing. If [SET] is pressed again without pressing the arrows, the display will go to receive 01 channel edit. NOTE: A channel that does not have a frequency set for it will have a dash to the right of it on the group/channel select screen.
- The [UP]/[DOWN] arrows will change the group number. Press [SET] again to set the group that was flashing. Now the group number will stop flashing and R1's channel number will start to flash.
- The [UP]/[DOWN] arrows will change the receive channel number. Press [SET] to set the channel that was selected. Now the second channel number will start to flash. If [SET] is pressed again without pressing the arrows, the display will go to the next channel number.
- After the last receive channel is decided upon, pressing [SET] will set that channel in the unit and start you over at the beginning of the group/channel select screen with nothing flashing.
- Pressing [MENU] will take you to the group/frequency select screen. NOTE: Pressing [MENU] after activity has occurred within the screen will return to the group/channel select screen with nothing flashing. Any change that had been done before the last [SET] was pressed will be aborted.
- Setting two channels the same is not allowed. If a channel is already set on the screen, the user no longer has that channel as an option to set into one of the other receivers.

### Group / Channel Select



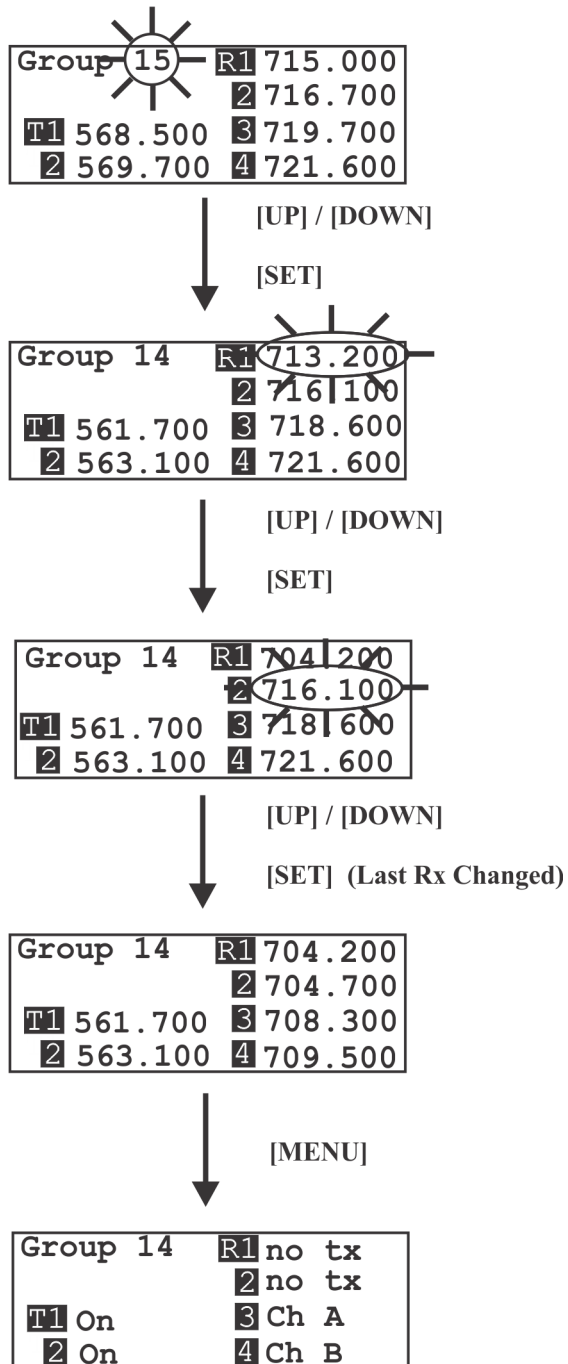
END

## Group/Frequency Select

The Group/Frequency select screen allows a user to set the group and select from a pre-determined number of frequencies on each receiver. Each frequency displayed on the right half of the screen corresponds to a channel number in the Group/Channel Screen.

- Press [MENU] twice to go to the Group/Frequency Select screen from the operating screen. Press [SET] to start the group number flashing.
- Press the [UP]/[DOWN] arrows to change the group number. The frequencies listed will reflect what is currently in that group. Pressing [SET] will select the group and start the selecting of predetermined frequencies within that group. The R1 frequency will start flashing. NOTE: The group number sets the transmit frequencies of factory defined groups and these are not editable. In user-programmed groups these are editable from the frequency edit screen.
- Pressing the [UP]/[DOWN] arrows will change the frequency of R1 to the pre-defined frequencies available. Pressing [SET] will accept the change and move you to the next channel to edit. If you had not press the arrow keys when the frequency was flashing, but instead [press [SET], you would have skipped to the next frequency to edit.
- After the last receive frequency is decided upon, pressing [SET] will save that last frequency and start you over at the beginning of the group/frequency select screen with nothing flashing.
- Pressing [MENU] will take you to the operating screen if this is a factory-defined group. If within a user programmed group, you will be taken to the frequency edit screen. NOTE: Pressing [MENU] after activity has occurred within the screen will return to the group/frequency edit screen with nothing flashing. Any change that had been done before the last [SET] was pressed will be aborted.

## Group / Frequency Select



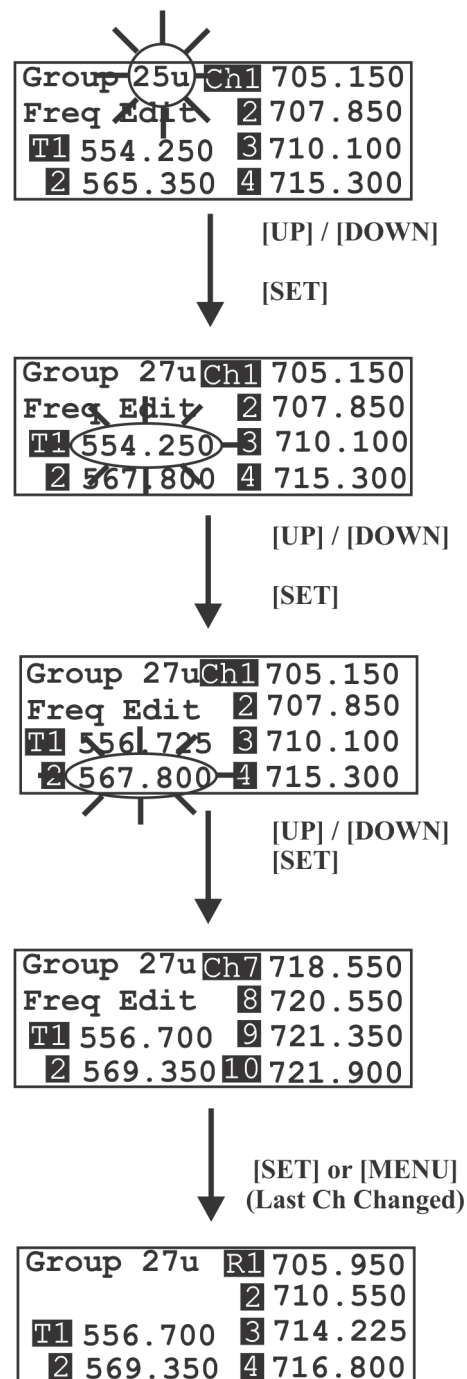
END

## Frequency Edit

### (User-Programmed Groups Only)

This menu only occurs for user-programmable groups or when copying to a user-programmable group. The Frequency Edit screen allows the user to set the group transmit frequencies and receive channel frequencies of a user-programmable group.

- Press [MENU] three times to go to the frequency select screen from the operating screen. Press [SET] to start the group number flashing. This screen allows the user to set the group and frequencies of user-programmed groups only.
- Press the [UP]/[DOWN] arrows to change the group number. The frequencies listed will reflect what is currently in that group, Dashes will be displayed in any slots that are not defined yet. Pressing [SET] will select the group and start the selecting of frequencies within that group. The T1 frequency will start flashing.
- Pressing the [UP]/[DOWN] arrows will change the frequency of T1 in 25kHz steps. Pressing [SET] will accept the change and start you editing T2. If you had not pressed the arrow keys when the frequency was flashing, but instead press [SET], you would have skipped to the next frequency to edit.
- After editing the transmit and the receive channel frequencies, pressing [SET] will save that last frequency and send you over to the beginning of the group/frequency select screen with nothing flashing. NOTE: Once the end of the displayed channel list is reached, the last displayed channel location will scroll to allow the user to edit the remaining channels.
- After action has occurred in the frequency edit screen pressing [MENU] will take you one menu back to the group/frequency select screen so that the user may see what frequencies the base receivers are now on. If no action had occurred, then pressing [MENU] will take you to the operating screen. NOTE: Besides a group change, any editing that occurs within this screen to frequencies DOES NOT take effect until the user exits the screen via setting the last channel or press [MENU].

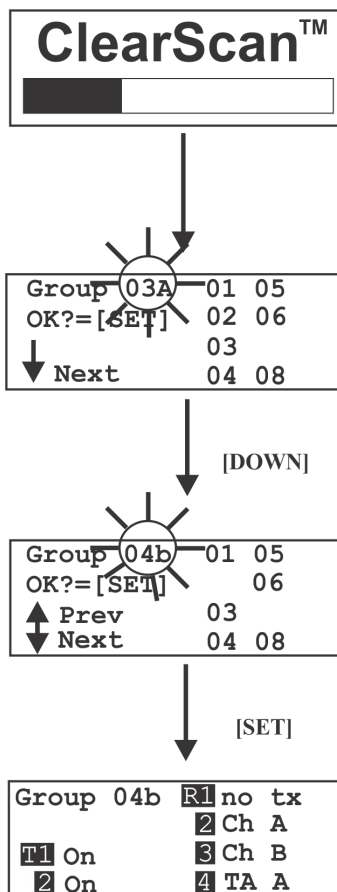


END

## ClearScan™

ClearScan™ performs a frequency scan of the factory-defined and any set-up user-programmable groups in order to find the group with the highest number of clear receive channels. After about 20-30 seconds, the group with the highest number of clear receive channels will be displayed. The next best group and so forth may be accessed with the [DOWN] and [UP] arrow buttons.

- Press and hold [MENU] + [SET] for three seconds to enter ClearScan™. The base station will now start searching all groups for the ones with the greatest number of receiver channels clear of interference.
- ClearScan™ will display the group that has the most interference free receive channels. These clear channels are displayed on the right half of the screen. Press [SET] to place the base station on this group and return to the operating screen. The first four receive channels displayed will be the ones set for the group. The [UP]/[DOWN] buttons may be used to select the next best group and so forth.



END

To achieve the best results quickly when using ClearScan™, please complete the following for setting up a single BTR-800 system:

- Turn off all wireless intercom and wireless microphone equipment.
- Turn on all wireless microphones and wireless monitor transmitters. Make sure that this equipment is distributed at least 3 to 5 feet apart from each other to minimize any frequency intermodulation effects.
- Turn on one TR-700/800/825 and perform the ClearScan function as described on page 55 and page 66 of this manual.
- When the first result is displayed on the TR, write this down along with the next 6 or 7 results. This number represents the specific BTR transmitter that should provide the best results for operation. This is referred to as the Group.
- Once you have recorded the first 6 or 7 results from the TR, turn off the TR unit.
- Turn on the BTR-700 or BTR-800 and perform the ClearScan function as described above. The results of the BTR will provide the number of Channels or TR transmitters that can operate in a given group.
- Since you have already established the best BTR Group (base station transmit frequency) to operate on, selection of the operating channels is now much easier.
- Simply match the number of TRs to operate on your system with the first and best Group number that you have recorded.
- When you have scrolled to the appropriate Group number that displays the number of belt packs to be used on the system, simply press [SET] on the BTR to place the BTR on the selected Group and Channel.
- Finally, go back to the TRs and program to the appropriate Group and Channel.

## Special Key Sequences

### Lockout

- Press [UP]+[DOWN] for three seconds to lock or unlock the base station. Pressing [MENU] will still function to view screens, but [SET] will no longer start any editing. ClearScan™, First use, Factory default are no longer accessible. The intercom channel A and B front panel 2-wire/4-wire selection is also locked into place. A padlock icon will be displayed on the second line of the display to the far left as an indication that the base station is locked out.

### Copy

- Press [SET]+[DOWN] for 3 seconds to copy any currently display group to a user-programmable group. Copy can be done from the group/channel select, group/frequency select or frequency edit screen. Once pressed, the words, “copy to” are displayed on the screen with the first empty user-programmable group flashing. If all the user-programmed groups were full, then the first programmable group is displayed. The [UP] or [DOWN] buttons may be used to select a different user-programmable group, if desired. Pressing [SET] pastes frequencies/channels to the group and takes the user to the frequency edit screen with T1 flashing.

### 1st Use Default

- Press [MENU] while turning on the base station to enter the 1st use default setup screen. This places the unit on group 01A with the four receivers set to channels 1-4 of the group. **Any user-programmed frequencies that had been entered previously are retained.** If lockout had been activated, the beltpack comes up where it was last left regardless of [MENU] being pressed on power-up.

### Factory Default

- Pressing all four buttons [MENU]+[SET]+[UP]+[DOWN] at the same time for three seconds places the unit on group 01A with the four receivers set to channels 1-4 of that group. This is just like base station 1st use default, except that **all user-programmed frequencies that had been entered previously are erased.** This function may take several seconds. If lockout had been activated, the beltpack comes up where it was last left regardless of these four keys being pressed.