



# Flom Test Labs

EMI, EMC, RF Testing Experts Since 1963

toll-free: (866) 311-3268  
fax: (480) 926-3598  
<http://www.flomlabs.com>  
[info@flomlabs.com](mailto:info@flomlabs.com)

**Date:** May 14, 2008

**Applicant:** Telex Communications, Inc.  
8601 E. Cornhusker Highway  
P.O. Box 5579  
Lincoln, NE 68505-5579

**Attention of:** Charles E. Conner, Project Engineer  
(402) 467-5321; FAX: -3279  
E-mail: [charlie.conner@us.telex.com](mailto:charlie.conner@us.telex.com)  
Jim Andersen  
Email: [jim.andersen@us.telex.com](mailto:jim.andersen@us.telex.com)

**Equipment:** TR-80N Belt-pack 614-698MHz  
**FCC ID:** B5DM530  
**FCC Rules:** 74H

Gentlemen:

Enclosed please find your copy of the Engineering Test Report for which you are subject to the restrictions as listed on the attached summary.

As you know, the FCC, after a TCB issues a Grant, still has 30 days to review a submission and request added information. It is your decision whether or not to market the equipment subject to a possible recall before the end of the 30 days.

If your equipment is still retained by us, it will be returned to you 30 days after approval is achieved. Our invoice for services has been directed to your Accounts Payable Department.

Should you need any clarification, just fax or phone. Thank you again for this order - it has been a pleasure to be of service.

Sincerely yours,

Hoosamuddin S. Bandukwala, Lab Director

enclosure(s)  
HSB/je



Flom Test Labs  
EMI, EMC, RF Testing Experts Since 1963

## Memo

**Date:** May 14, 2008

**Applicant:** Telex Communications, Inc.  
8601 E. Cornhusker Highway  
P.O. Box 5579  
Lincoln, NE 68505-5579

**Equipment:** TR-80N Belt-pack 614-698MHz  
**FCC ID:** B5DM530

Please note that the enclosed Reports reflect the results of tests performed to the currently published Federal Communications Commissions Rules and Regulations.

Should the FCC's Examiners' interpretations request new and unpublished requirements, we will be pleased to provide them. We will invoice you accordingly, i.e. for the time spent on re-testing, providing the amended pages and/or Reports and for the time necessary to be spent on electronic filing. We will of course provide you with copies of any of the additions.

We regret any added expense to the Applicants, but of late the FCC continues to change their requirements without any prior written publication and/or notices.

As in the past, we will continue to provide all liaison with the FCC necessary for the successful conclusion of your project and the receipt of your Grant of Equipment Authorization.

Sincerely yours,

Hoosamuddin S. Bandukwala, Lab Director

## Summary of Restrictions

1. All submissions to the FCC are subject to **their** Examiner's interpretation.
2. Please allow from 60 to 90 days before hearing from the FCC with regard to any submission.
3. The FCC can set aside any action; modify or set aside any action, within 30 days. (FCC Rule 1.108, 1.113).
4. Under Rule 2.803, if device is not type accepted/certificated then it must **not** be sold, leased, offered for sale, imported, shipped or distributed or advertised for sale.
5. FCC can revoke its certificates at any time if the equipment does not meet or **continue** to meet their Rules. (Rule Parts 2.927, 2.939).
6. FCC can request a sample at any time (2.936).

M. Flom Associates, Inc.

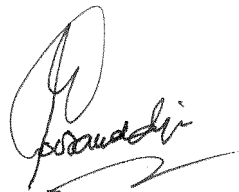

Hoosamuddin S. Bandukwala, Lab Director



**Flom Test Labs**  
EMI, EMC, RF Testing Experts Since 1963

toll-free: (866) 311-3268  
fax: (480) 926-3598  
<http://www.flomlabs.com>  
[info@flomlabs.com](mailto:info@flomlabs.com)

**Date:** May 14, 2008

Federal Communications Commission  
Via: Electronic Filing

**Attention:** Authorization & Evaluation Division

**Applicant:** Telex Communications, Inc.  
**Equipment:** TR-80N Belt-pack 614-698MHz  
**FCC ID:** B5DM530  
**FCC Rules:** 74H

Gentlemen:

On behalf of the Applicant, enclosed please find Application Form 731, Engineering Test Report and all pertinent documentation, the whole for approval of the referenced equipment as shown.

We trust the same is in order. Should you need any further information, kindly contact the writer who is authorized to act as agent.

Sincerely yours,

Hoosamuddin S. Bandukwala, Lab Director

enclosure(s)  
cc: Applicant  
HSB/je

Flom Test Labs  
3356 N. San Marcos Place, Suite 107  
Chandler, Arizona 85225-7176  
(866) 311-3268 phone, (480) 926-3598 fax

FCC ID: B5DM530  
p0840025, d0850035 Rev 3.0



**Flom Test Labs**  
EMI, EMC, RF Testing Experts Since 1963

toll-free: (866) 311-3268  
fax: (480) 926-3598  
<http://www.flomlabs.com>  
[info@flomlabs.com](mailto:info@flomlabs.com)

## Test Report

for

FCC ID: B5DM530

**Model:** TR-80N Belt-pack 614-698MHz

to

**Federal Communications Commission**

Rule Part(s) 74H

Date of report: May 14, 2008

Date of revised report: August 20, 2008

**On the Behalf of the  
Applicant:**

Telex Communications, Inc.

**At the Request of:**

Telex Communications, Inc.  
8601 E. Cornhusker Highway  
P.O. Box 5579  
Lincoln, NE 68505-5579

**Attention of:**

Charles E. Conner, Project Engineer  
(402) 467-5321; FAX: -3279  
E-mail: [charlie.conner@us.telex.com](mailto:charlie.conner@us.telex.com)  
Jim Andersen  
Email: [jim.andersen@us.telex.com](mailto:jim.andersen@us.telex.com)

Supervised by:

Hoosamuddin S. Bandukwala, Lab Director

## Revision History

Revision	Date	Revised By	Reason for revision
1.0	May 14, 2008	J. Erhard	Original Document
2.0	July 9, 2008	J. Erhard	Edit report per TCB request
3.0	August 20, 2008	M.Wyman	Edit report per TCB request
4.0	September 9, 2008	Hoosam B.	Frequency updated

List of Exhibits

(FCC **Certification** (Transmitters) - Revised 9/28/98)

Applicant: Telex Communications, Inc.

FCC ID: B5DM530

**By Applicant:**

1. Letter of Authorization
2. Confidentiality Request: 0.457 And 0.459
3. Identification Drawings, 2.1033(c)(11)
  - Label
  - Location of Label
  - Compliance Statement
  - Location of Compliance Statement
4. Photographs, 2.1033(c)(12)
5. Documentation: 2.1033(c)
  - (3) User Manual
  - (9) Tune Up Info
  - (10) Schematic Diagram
  - (10) Circuit Description
    - Block Diagram
    - Parts List
    - Active Devices
6. MPE/SAR Report

**By F.T.L.:**

- A. Testimonial & Statement of Certification

## **The Applicant has been cautioned as to the following:**

### **15.21 Information to the User.**

The users manual or instruction manual for an intentional radiator shall caution the user that changes or modifications not expressly approved by the party responsible for compliance could void the user's authority to operate the equipment.

### **15.27(a) Special Accessories.**

Equipment marketed to a consumer must be capable of complying with the necessary regulations in the configuration in which the equipment is marketed. Where special accessories, such as shielded cables and/or special connectors are required to enable an unintentional or intentional radiator to comply with the emission limits in this part, the equipment must be marketed with, i.e. shipped and sold with, those special accessories. However, in lieu of shipping or packaging the special accessories with the unintentional or intentional radiator, the responsible party may employ other methods of ensuring that the special accessories are provided to the consumer, without additional charge.

Information detailing any alternative method used to supply the special accessories for a grant of equipment authorization or retained in the verification records, as appropriate. The party responsible for the equipment, as detailed in § 2.909 of this chapter, shall ensure that these special accessories are provided with the equipment. The instruction manual for such devices shall include appropriate instructions on the first page of text concerned with the installation of the device that these special accessories must be used with the device. It is the responsibility of the user to use the needed special accessories supplied with the equipment.



## Testimonial and Statement of Certification

**This is to Certify:**

1. **That** the application was prepared either by, or under the direct supervision of, the undersigned.
2. **That** the technical data supplied with the application was taken under my direction and supervision.
3. **That** the data was obtained on representative units, randomly selected.
4. **That**, to the best of my knowledge and belief, the facts set forth in the application and accompanying technical data are true and correct.

Certifying Engineer:

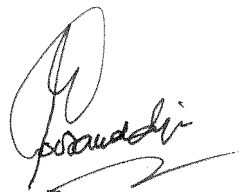

Hoosamuddin S. Bandukwala, Lab Director

## Table of Contents

<u>Rule</u>	<u>Description</u>	<u>Page</u>
2.1033(c)(14)	Rule Summary	2
	Standard Test Conditions and Engineering Practices	3
2.1033(c)	General Information Required	4
2.1046(a)	Carrier Output Power (Conducted)	6
2.1046(a)	ERP Carrier Power (Radiated)	7
2.1051	Unwanted Emissions (Transmitter Conducted)	8
2.1053(a)	Field Strength of Spurious Radiation	11
RSS-123 8.0	Receiver Spurious Emissions	13
2.1049(c)(1)	Emission Masks (Occupied Bandwidth)	14
90.214	Transient Frequency Behavior	17
2.1047(a)	Audio Low Pass Filter (Voice Input)	18
2.1047(b)	Modulation Limiting	19
2.1055(a)(1)	Frequency Stability (Temperature Variation)	21
2.1055(b)(1)	Frequency Stability (Voltage Variation)	22
	Test Equipment Utilized	27

Required information per ISO 17025-2005, paragraph 5.10.2:

a) **Test Report**

b) Laboratory: Flom Test Lab  
(FCC: 31040/SIT) 3356 N. San Marcos Place, Suite 107  
(Canada: IC 2044-A) Chandler, AZ 85225

c) Report Number: d0850035

d) Client: Telex Communications, Inc.  
8601 E. Cornhusker Highway  
P.O. Box 5579  
Lincoln, NE 68505-5579

e) Identification: TR-80N Belt-pack 614-698MHz  
FCC ID: B5DM530

EUT Description: Wireless belt-pack

f) EUT Condition: Not required unless specified in individual tests.

g) Report Date: May 14, 2008  
EUT Received:

h, j, k): As indicated in individual tests.

i) Sampling method: No sampling procedure used.

l) Uncertainty: In accordance with FTL internal quality manual.

m) Supervised by:

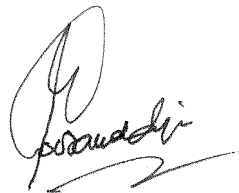

Hoosamuddin S. Bandukwala, Lab Director

n) Results: The results presented in this report relate only to the item tested.

o) Reproduction: This report must not be reproduced, except in full, without written permission from this laboratory.

Accessories used during testing:

Type	Quantity	Manufacturer	Model	Serial No.	FCC ID
------	----------	--------------	-------	------------	--------

Sub-part

2.1033(c)(14):

## Test and Measurement Data

All tests and measurement data shown were performed in accordance with FCC Rules and Regulations, Volume II; Part 2, Sub-part J, Sections 2.947, 2.1033(c), 2.1041, 2.1046, 2.1047, 2.1079, 2.1051, 2.1053, 2.1055, 2.1057, RSS 123 and the following individual Parts:

- 15 – Radio Frequency Devices (unlicensed)
- 21 – Domestic Public Fixed Radio Services
- 22 – Public Mobile Services
- 22 Subpart H - Cellular Radiotelephone Service
- 22.901(d) - Alternative technologies and auxiliary services
- 23 – International Fixed Public Radiocommunication services
- 24 – Personal Communications Services
- 74 Subpart H - Low Power Auxiliary Stations
- 80 – Stations in the Maritime Services
- 80 Subpart E - General Technical Standards
- 80 Subpart F - Equipment Authorization for Compulsory Ships
- 80 Subpart K - Private Coast Stations and Marine Utility Stations
- 80 Subpart S - Compulsory Radiotelephone Installations for Small Passenger Boats
- 80 Subpart T - Radiotelephone Installation Required for Vessels on the Great Lakes
- 80 Subpart U - Radiotelephone Installations Required by the Bridge-to-Bridge Act
- 80 Subpart V - Emergency Position Indicating Radio Beacons (EPIRB'S)
- 80 Subpart W - Global Maritime Distress and Safety System (GMDSS)
- 80 Subpart X - Voluntary Radio Installations
- 87 – Aviation Services
- 90 – Private Land Mobile Radio Services
- 94 – Private Operational-Fixed Microwave Service
- 95 Subpart A - General Mobile Radio Service (GMRS)
- 95 Subpart C - Radio Control (R/C) Radio Service
- 95 Subpart D - Citizens Band (CB) Radio Service
- 95 Subpart E - Family Radio Service
- 95 Subpart F - Interactive Video and Data Service (IVDS)
- 97 - Amateur Radio Service
- 101 – Fixed Microwave Services

## Standard Test Conditions and Engineering Practices

Except as noted herein, the following conditions and procedures were observed during the testing:

In accordance with ANSI TIA 603-C-2001 and unless otherwise indicated in the specific measurement results, the ambient temperature of the actual EUT was maintained within the range of 10° to 40°C (50° to 104 °F) unless the particular equipment requirements specify testing over a different temperature range. Also, unless otherwise indicated, the humidity levels were in the range of 10% to 90% relative humidity.

Measurement results, unless otherwise noted, are worst-case measurements.

### **A2LA**

“A2LA has accredited Flom Test Labs, Inc. Chandler, AZ for technical competence in the field of Electrical testing. The accreditation covers the specific tests and types of tests listed on the agreed scope of accreditation. This laboratory meets the requirements of ISO 17025:2005 ‘General Requirements for the Competence of Testing and Calibration Laboratories’ and any additional program requirements in the identified field of testing.”

Please refer to [www.a2la.org](http://www.a2la.org) for current scope of accreditation.

Certificate number: 2152.01



**IC O.A.T.S. Number: 2044A-1**

## List of General Information Required for Certification

In Accordance with FCC Rules and Regulations,  
Volume II, Part 2, 74H, and RSS 123Sub-part 2.1033

(c)(1):

**Name and Address of Applicant:** Telex Communications, Inc.  
8601 E. Cornhusker Highway  
P.O. Box 5579  
Lincoln, NE 68505-5579

**Manufacturer:** Telex Communications, Inc.  
8601 E. Cornhusker Highway  
P.O. Box 5579  
Lincoln, NE 68505-5579

(c)(2): **FCC ID:** B5DM530

**Model Number:** TR-80N Belt-pack 614-698MHz

(c)(3): **Instruction Manual(s):**

Please see attached exhibits

(c)(4): **Type of Emission:** FM

(c)(5): **Frequency Range, MHz:** 614 to 697

(c)(6): **Power Rating, Watts:** 0.092 W  
 Switchable       Variable       N/A

**FCC Grant Note:** None

(c)(7): **Maximum Power Rating, Watts:** 1W

**DUT Results:** Passes  Fails

Subpart 2.1033 (continued)

(c)(8): Voltages & currents in all elements in final RF stage, including final transistor or solid-state device:

Collector Current, A	=	0.025
Collector Voltage, Vdc	=	4.75
Supply Voltage, Vdc	=	9.0

(c)(9): **Tune-Up Procedure:**

Please see attached exhibits

(c)(10): **Circuit Diagram/Circuit Description:**

Including description of circuitry & devices provided for determining and stabilizing frequency, for suppression of spurious radiation, for limiting modulation and limiting power.

Please see attached exhibits

(c)(11): **Label Information:**

Please see attached exhibits

(c)(12): **Photographs:**

Please see attached exhibits

(c)(13): **Digital Modulation Description:**

Attached Exhibits  
 N/A

(c)(14): **Test and Measurement Data:**

Follows

**Name of Test:** Carrier Output Power (Conducted)  
**Specification:** 2.1046(a)  
**Test Equipment Utilized:** See Equipment List

**Test Date:** 2/8/2008

**Measurement Procedure**

The UUT was connected directly to a power meter and the peak output power was measured.

**Test Set-Up**

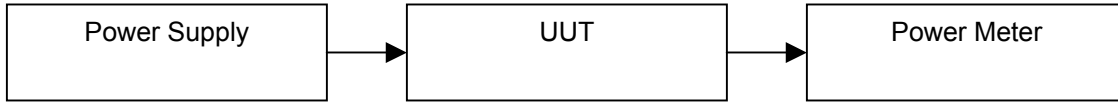

**Test Results**

Tuned Frequency MHz	Recorded Measurement dBm	Limit dBm	Result
614 MHz	19.24	30	Pass
668 MHz	19.67	30	Pass



**Name of Test:** ERP Carrier Power (Radiated)  
**Specification:** 2.1046(a)  
**Test Equipment Utilized** See Equipment List

**Test Date:** 2/9/2008

**Measurement Procedure**

**Definition**

The average radiated power of a licensed device is the equivalent power required, when delivered to a half-wave dipole or horn antenna, to produce at a distant point the same average received power as produced by the licensed device.

**Method of Measurement:**

- A) Connect the equipment as illustrated. Place the transmitter to be tested on the turntable in the standard test site.

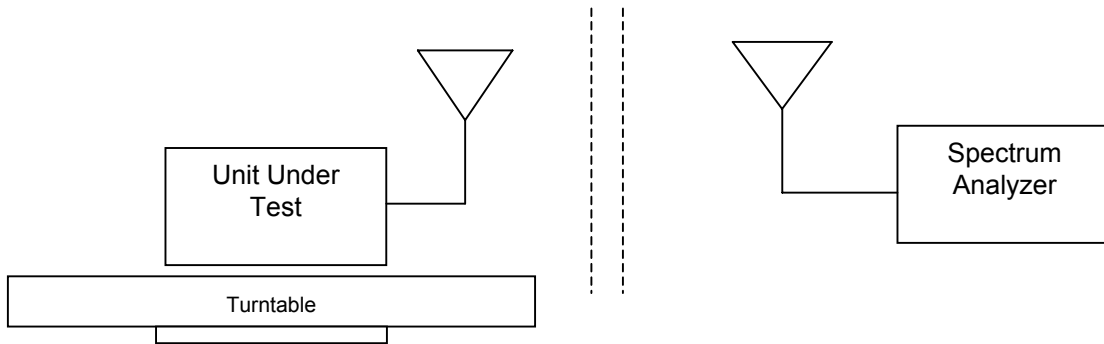

- B) Raise and lower the test antenna from 1m to 6 m with the transmitter facing the antenna and record the highest received signal in dB as LVL.
- C) Repeat step B) for seven additional readings at 45° interval positions of the turntable.
- D) Replace the transmitter under test with a half-wave or horn vertically polarized antenna. The center of the antenna should be at the same location as the transmitter under test. Connect the antenna to a signal generator with a known output power and record the path loss in dB or LOSS.
- E) Calculate the average radiated output power from the readings in step C) and D) by the following:  
**average radiated power = 10 \* log<sub>10</sub>(P<sub>LVL</sub> - P<sub>Loss</sub>)(1000), (dBm)**

**Test results**

Frequency Tuned, MHz	Frequency Emission, MHz	ERP, dBm
614.000	613.99	17.2
668.000	667.99	17.8

**Name of Test:** Unwanted Emissions (Transmitter Conducted)  
**Specification:** 2.1051  
**Test Equipment Utilized:** See Equipment List **Test Date:** 2/8/2008

**Measurement Procedure**

The UUT was connected directly to a spectrum analyzer. The transmitter conducted spurious emissions were plotted and compared to the limits for both FCC 74.861 and RSS-123 Section 6.3.

**Test Set-Up**

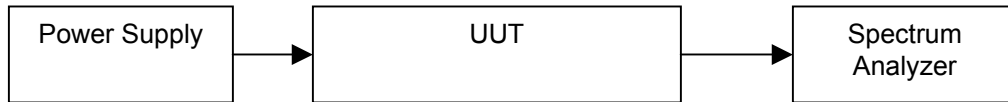

**Test Results Summary table**

Tuned Frequency MHz	Emission Frequency MHz	Measured Value dBm	RSS 123 Limit dBm	Result
614	1227	-43.65	-25	Pass
668	1335	-43.68	-25	Pass

The RSS 123 limit and procedure is more restrictive and that data has been provided. All FCC requirements are also met.

### 614 MHz conducted Emission Plots

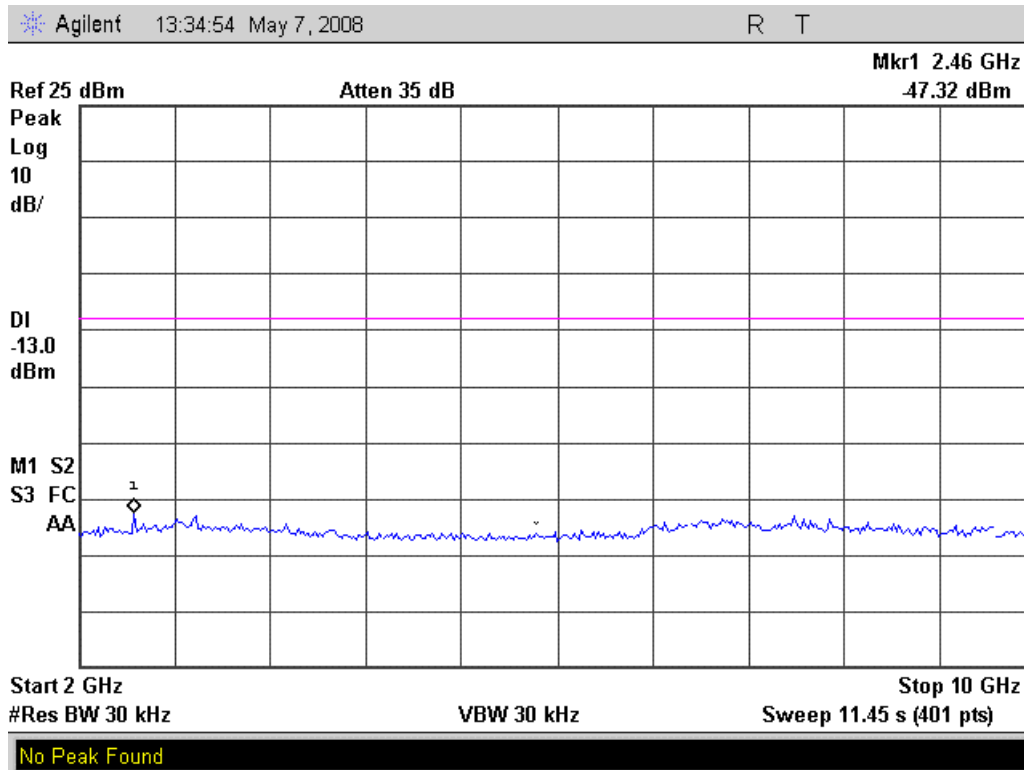
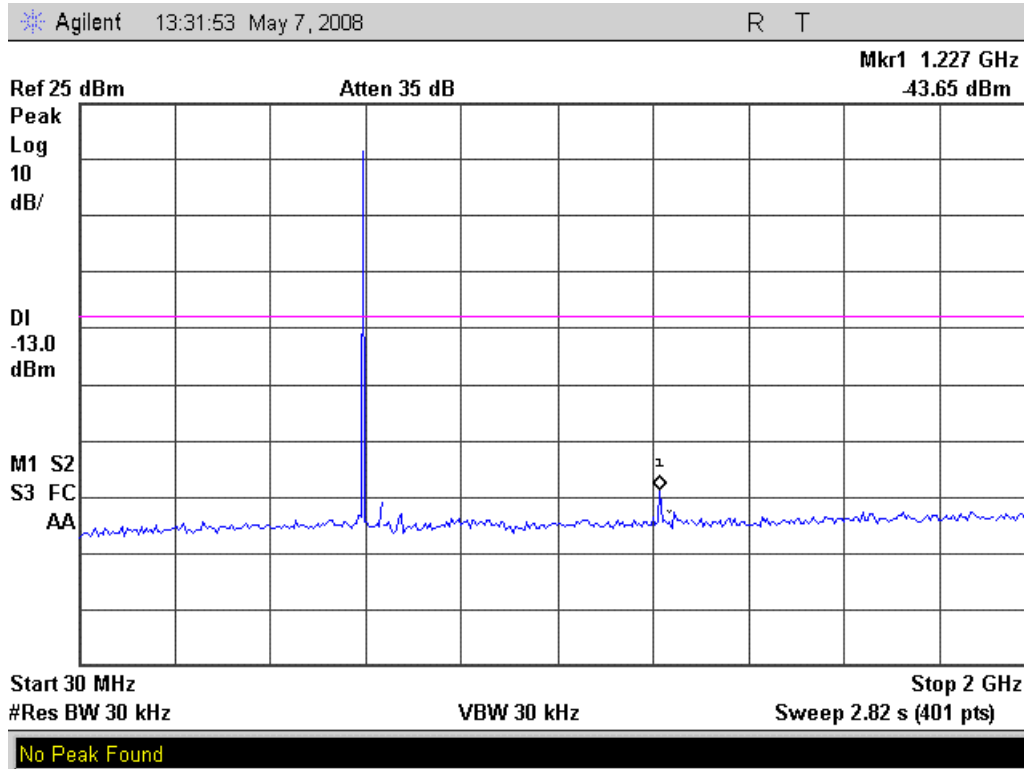

### 668 MHz conducted Emission Plots

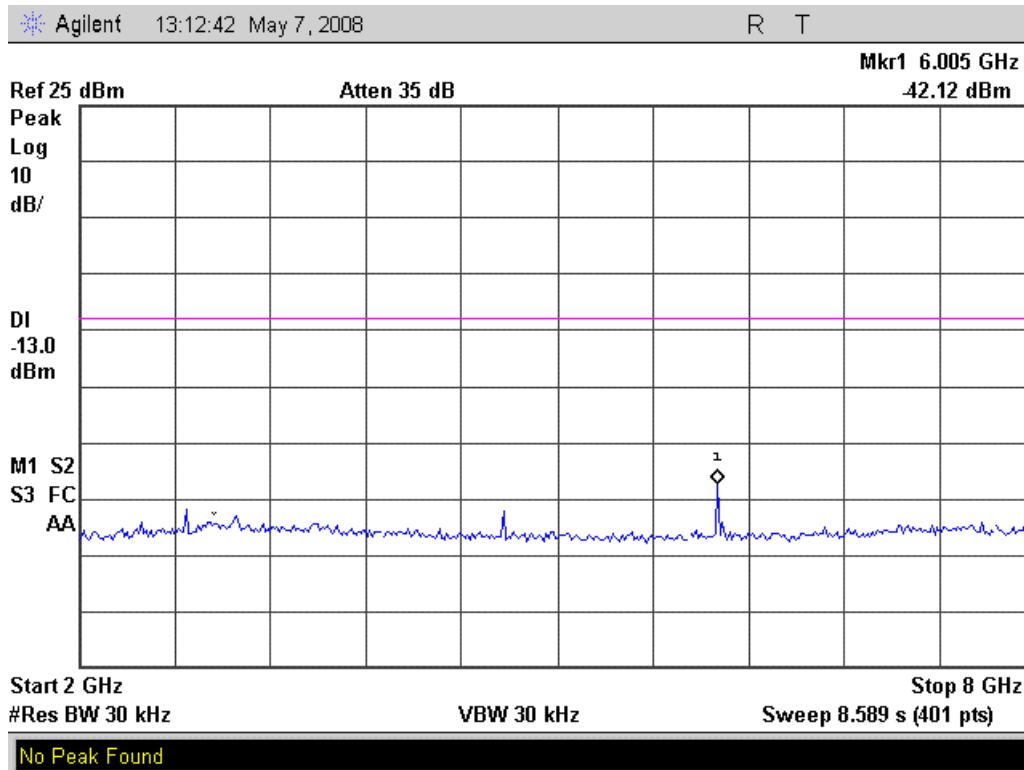
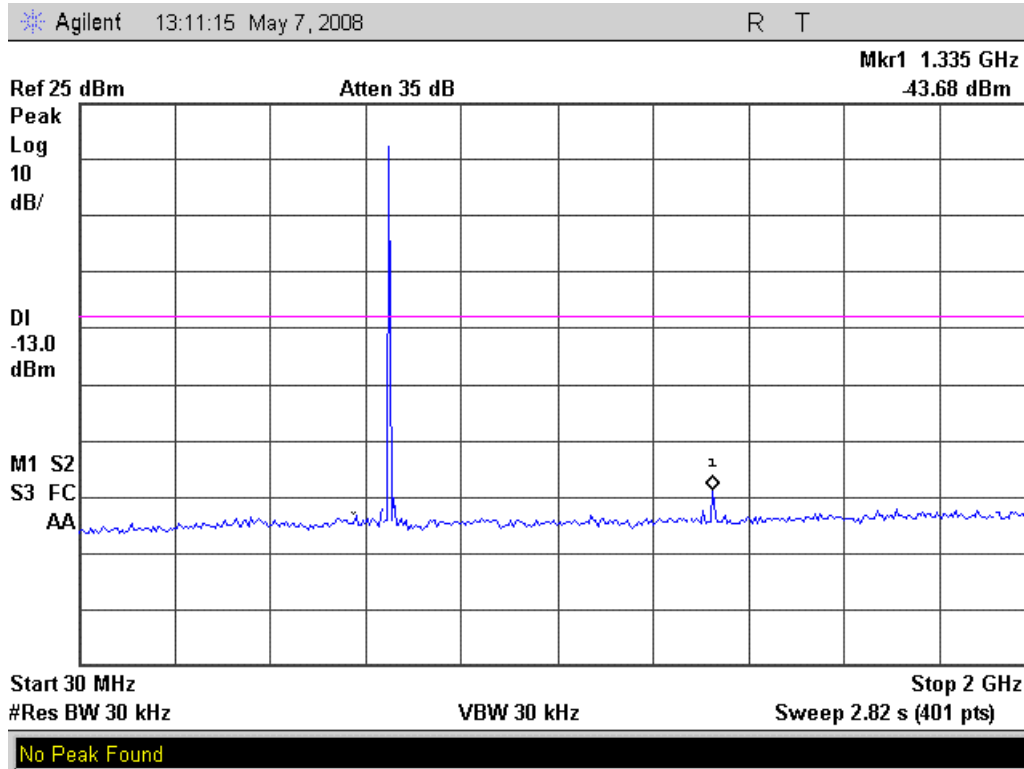

**Name of Test:** Field Strength of Spurious Radiation  
**Specification:** 2.1053(a)  
**Test Equipment Utilized:** See Equipment List

**Test Date:** 5/9/2008

### Measurement Procedure

**Definition:**

Radiated spurious emissions are emissions from the equipment when transmitting into a non-radiating load on a frequency or frequencies, which are outside an occupied band sufficient to ensure transmission of information of required quality for the class of communications, desired.

**Method of Measurement:**

A) Connect the equipment as illustrated below.

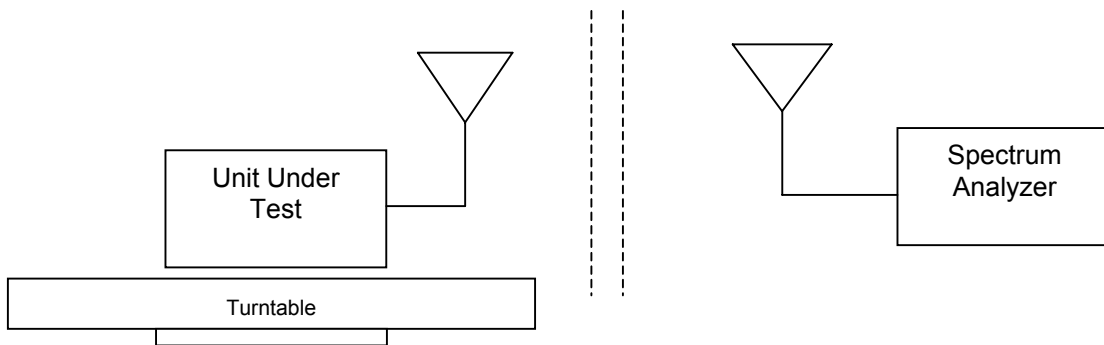

- B) Adjust the spectrum analyzer for the following settings:
- 1) Resolution Bandwidth 100 kHz (<1 GHz), 1 MHz (> 1GHz).
  - 2) Video Bandwidth  $\geq 3$  times Resolution Bandwidth, or 30 kHz (22.917)
  - 3) Sweep Speed  $\leq 2000$  Hz/second
  - 4) Detector Mode = Mean or Average Power
- C) Place the transmitter to be tested on the turntable in the standard test site. The transmitter is transmitting into a non-radiating load that is placed on the turntable. The RF cable to this load should be of minimum length.
- D) For each spurious measurement the test antenna should be adjusted to the correct length for the frequency involved. This length may be determined from a calibration ruler supplied with the equipment. Measurements shall be made from the lowest radio frequency generated in the equipment to the tenth harmonic of the carrier, except for the region close to the carrier equal to  $\pm$  the test bandwidth (see section 1.3.4.4).
- E) For each spurious frequency, raise and lower the test antenna from 1 m to 4 m to obtain a maximum reading on the spectrum analyzer with the test antenna at horizontal polarity. Repeat this procedure to obtain the highest possible reading. Record this maximum reading.
- F) Repeat step E) for each spurious frequency with the test antenna polarized vertically.

G) Reconnect the equipment as illustrated.

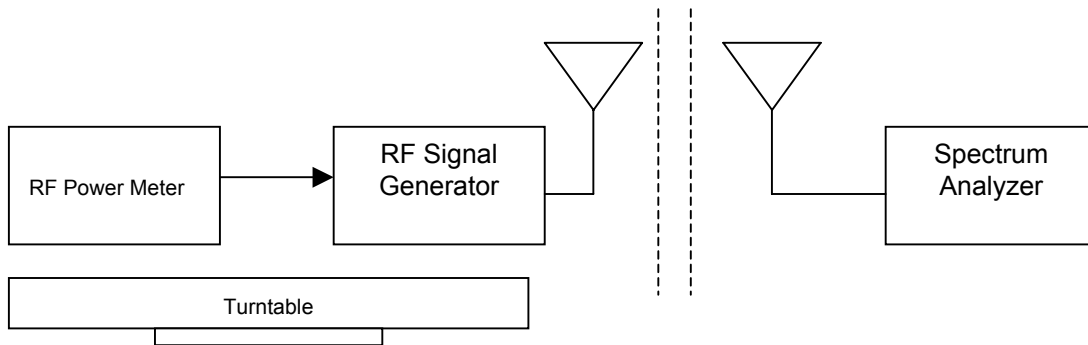

H) Keep the spectrum analyzer adjusted as in step B).

I) Remove the transmitter and replace it with a substitution antenna (the antenna should be half-wavelength for each frequency involved). The center of the substitution antenna should be approximately at the same location as the center of the transmitter. At lower frequencies, where the substitution antenna is very long, this will be impossible to achieve when the antenna is polarized vertically. In such case the lower end of the antenna should be 0.3 m above the ground.

J) Feed the substitution antenna at the transmitter end with a signal generator connected to the antenna by means of a non-radiating cable. With the antennas at both ends horizontally polarized and with the signal generator tuned to a particular spurious frequency, raise and lower the test antenna to obtain a maximum reading at the spectrum analyzer. Adjust the level of the signal generator output until the previously recorded maximum reading for this set of conditions is obtained. This should be done carefully repeating the adjustment of the test antenna and generator output.

K) Repeat step J) with both antennas vertically polarized for each spurious frequency.

L) Calculate power in dBm into a reference ideal half-wave dipole antenna by reducing the readings obtained in steps J) and K) by the power loss in the cable between the generator and the antenna and further corrected for the gain of the substitution antenna used relative to an ideal half-wave dipole antenna.

M) The levels recorded in step L) are absolute levels of radiated spurious emissions in dBm. The radiated spurious emissions in dB can be calculated by the following:

Radiated spurious emissions dB =

$$10\log_{10}(\text{TX power in watts}/0.001) - \text{the levels in step I)}$$

NOTE: It is permissible that other antennas provided can be referenced to a dipole.

Frequency Tuned, MHz	Frequency Emission, MHz	ERP, dBm
614.000	1227.99	-30.9
668.000	1335.99	-33.4

No other emissions were detectable .

**Name of Test:** Receiver Spurious Emissions  
**Specification:** RSS-123 8.0  
**Test Equipment Utilized** See Equipment List

**Test Date:** 5/9/2008

**Test Procedure**

The UUT was tested in an Open Area Test Site (OATS) set 3m from the receiving antenna. A spectrum analyzer was used to verify that the UUT met the requirements for Radiated Emissions. The UUT was tested by rotating it 360° with the antennas in both the vertical and horizontal orientation and raised from 1 to 4 meters to ensure the TX signal levels were maximized. All emissions from 30 MHz to 2 GHz were examined.

**Test Setup**

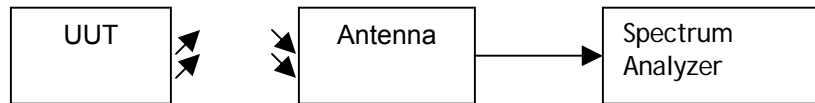

**Receiver Spurious Emissions**

Tuned Frequency (MHz)	Emission Freq (MHz)	Measured Value (dBuV/m)	Correction Factor (dB)	Corrected Value (dBuV/m)	Limit (dBuV/m)	Margin dB
482	53.606	21.8	.9	22.7	39.1	-16.5
608	148.618	21.5	4.6	26.5	43.5	-17.0
545	266.456	21.5	6.4	28.0	46.4	-18.4
482	416.725	21.5	8.9	30.4	46.4	-16.0
545	598.457	21.7	12.4	34.1	46.4	-12.3
545	834.192	21.7	15.4	37.1	46.4	-9.4

No other emissions were detectable.

**Name of Test:** Emission Masks (Occupied Bandwidth)  
**Specification:** 2.1049(c)(1)  
**Test Equipment Utilized:** See Equipment List

**Test Date:** 5/8/2008

**Measurement Procedure**

- A) The EUT and test equipment were set up as shown below
- B) For EUTs supporting audio modulation, the audio signal generator was adjusted to the frequency of maximum response and with output level set for  $\pm 2.5/\pm 1.25$  kHz deviation (or 50% modulation). With level constant, the signal level was increased 16 dB.
- C) For EUTs supporting digital modulation, the digital modulation mode was operated to its maximum extent.
- D) The Occupied Bandwidth was measured with the Spectrum Analyzer controls set as shown on the test results.

**Test Set-Up**

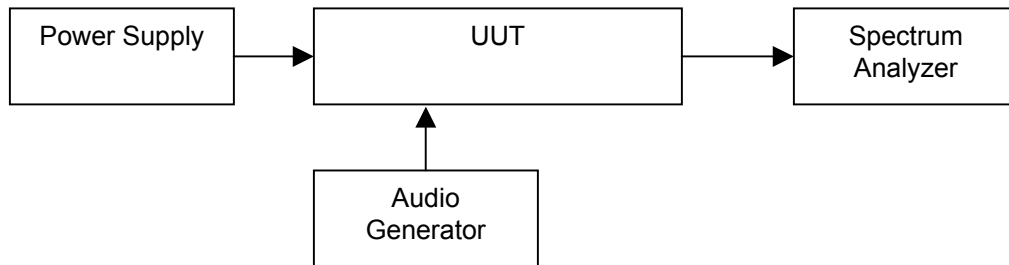

**Occupied Bandwidth Results Table**

Tuned Frequency (MHz)	6dB Bandwidth (kHz)	99% Bandwidth (kHz)
614	12.1	16.5



### Measurement Results 614 MHz

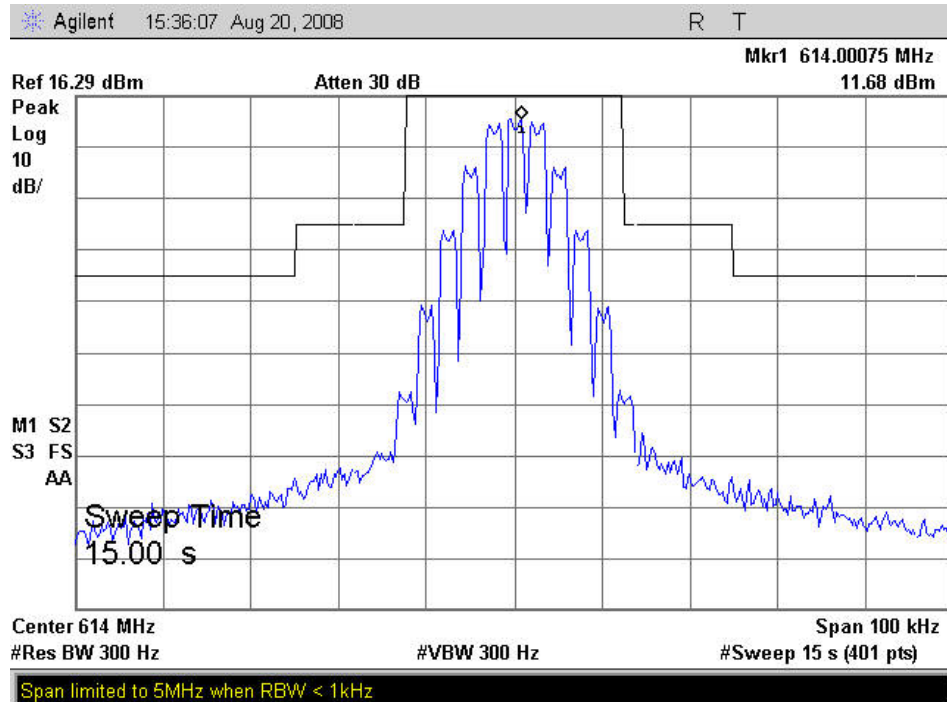
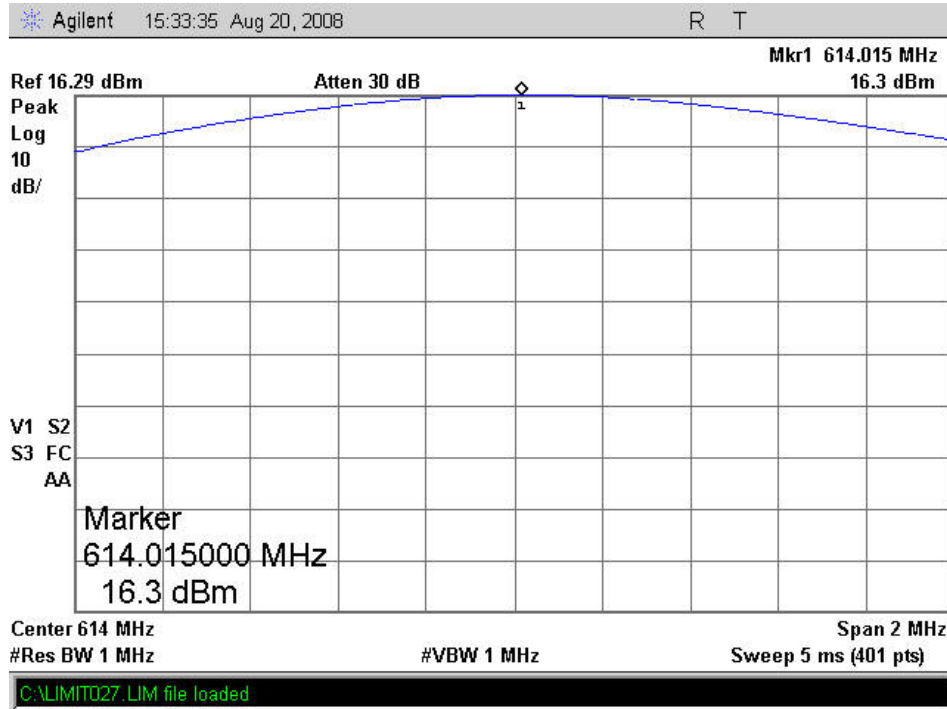

Agilent 15:37:52 Aug 20, 2008 R T

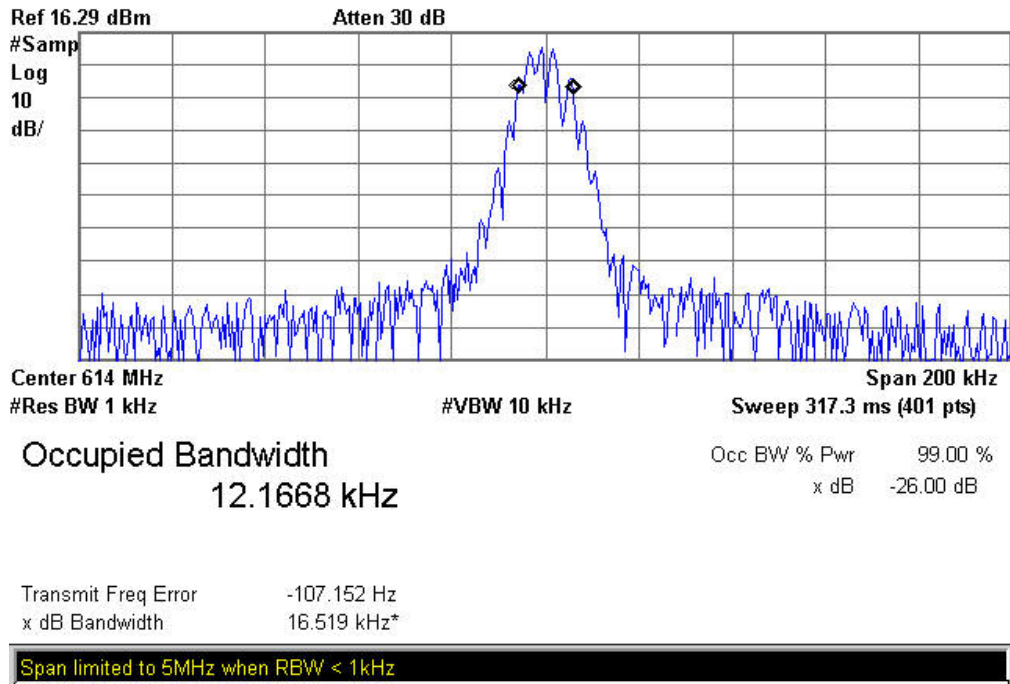

**Name of Test:** Transient Frequency Behavior  
**Specification:** 90.214  
**Test Equipment Utilized:** N/A

**Test Date:** N/A

**This test is not applicable as the frequency range of operation not covered by part 74H or 90.214.**

**Name of Test:** Audio Low Pass Filter (Voice Input)  
**Specification:** 2.1047(a)  
**Test Equipment Utilized:** See Equipment List

**Test Date:** 7/8/2008

**Measurement Procedure**

- A) The EUT and test equipment were set up such that the audio input was connected at the input to the modulation limiter, and the modulated stage.
- B) The audio output was connected at the output to the modulated stage.

**Transmitter Test Set-Up**

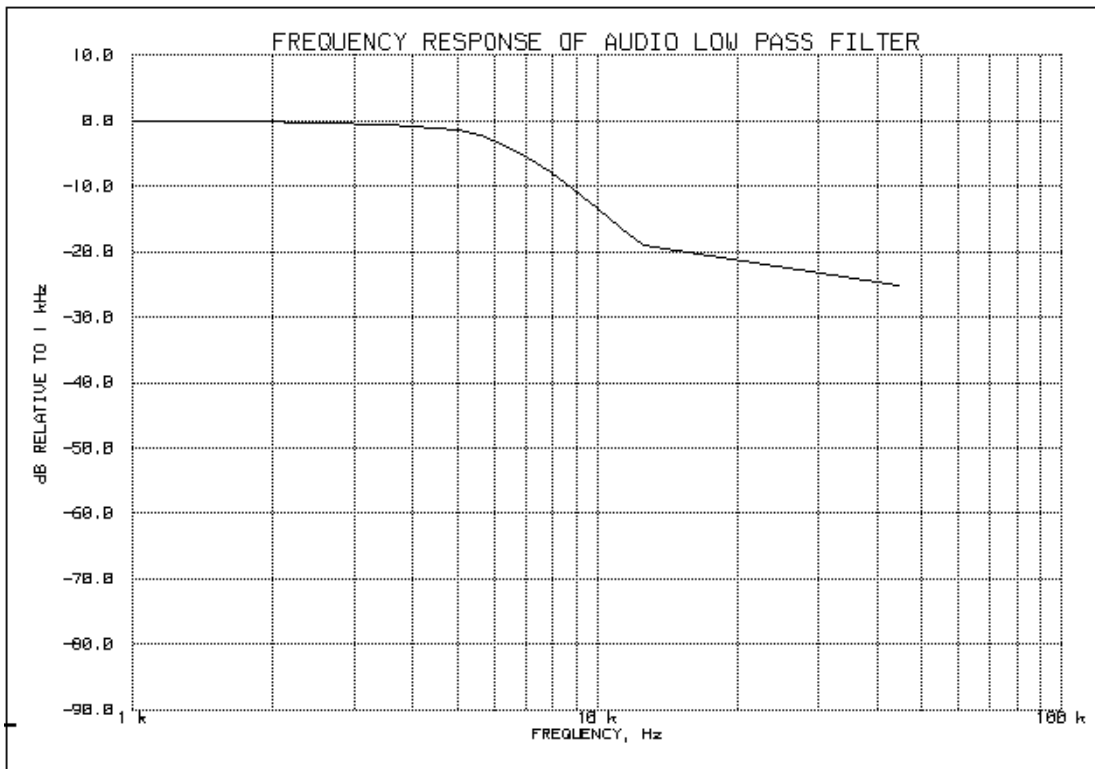
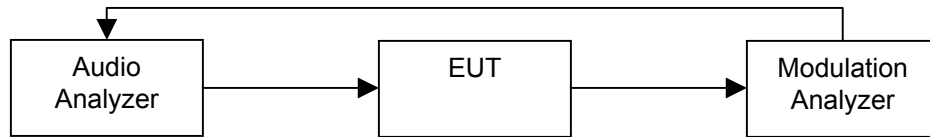

**Name of Test:** Modulation Limiting  
**Specification:** 2.1047(b)  
**Test Equipment Utilized:** See Equipment List

**Test Date:** 5/12/2008

### Measurement Procedure

- A) The signal generator was connected to the input of the EUT as shown below.
- B) The modulation response was measured for each of three frequencies (one of which was the frequency of maximum response), and the input voltage was varied and was observed on an HP 8901A Modulation Analyzer.
- C) The input level was varied from 30% modulation ( $\pm 1.5$  kHz deviation) to at least 20 dB higher than the saturation point.
- D) Measurements were performed for both negative and positive modulation and the respective results were recorded.

### Transmitter Test Set-Up

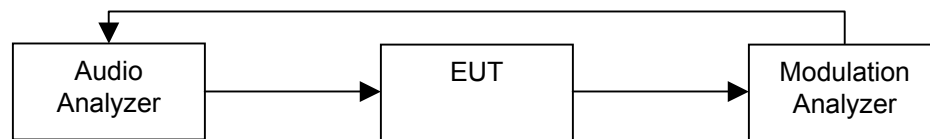

Measurement Results Positive Peaks

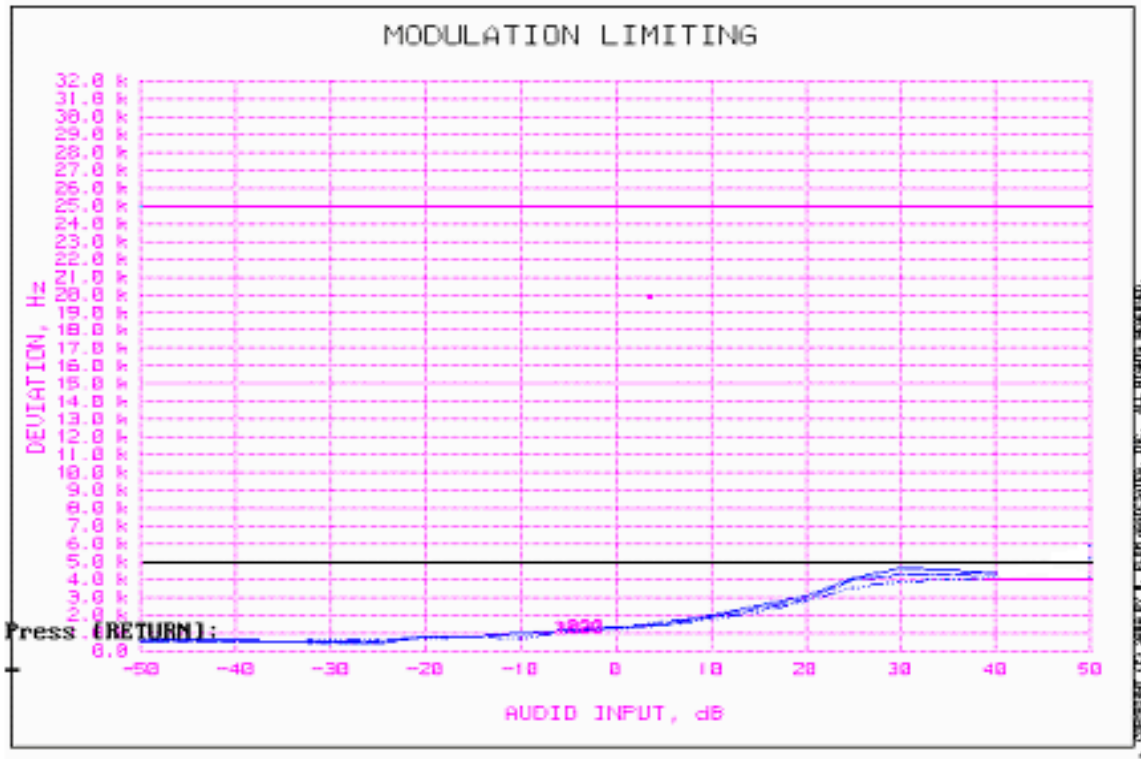

Measurement Results Negative Peaks

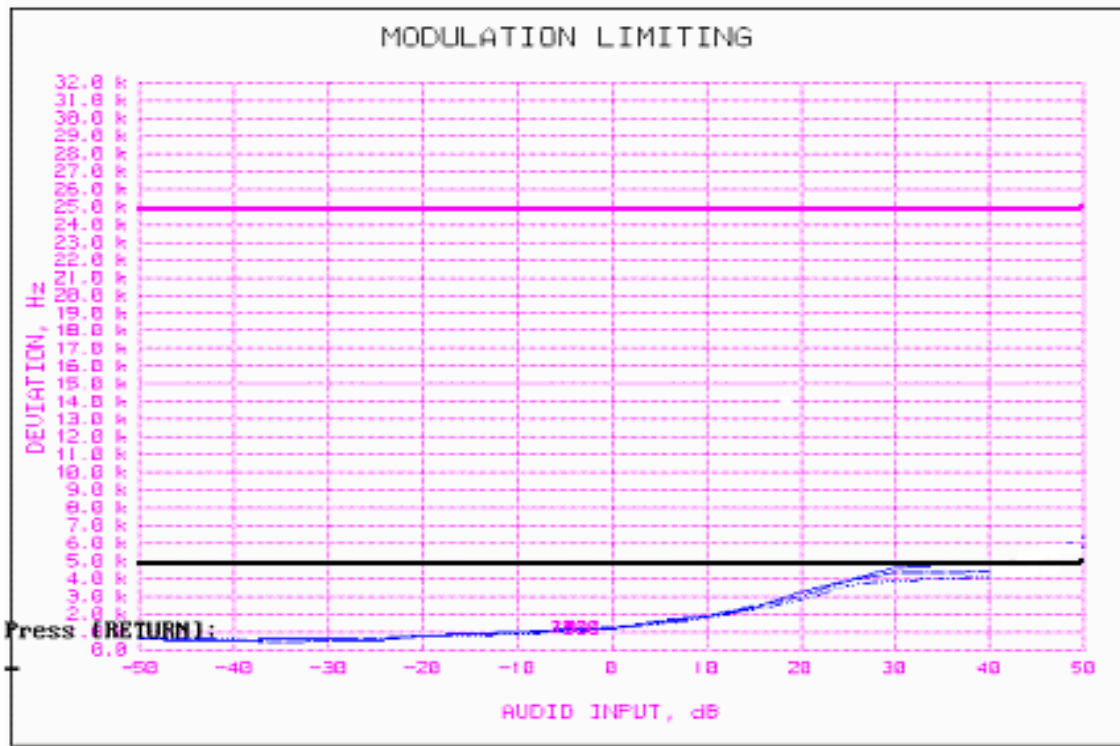

**Name of Test:** Frequency Stability (Temperature Variation)  
**Specification:** 2.1055(a)(1)  
**Test Equipment Utilized:** See Equipment List

**Test Date:** 5/8/2008

**Measurement Procedure**

The EUT was placed in an environmental test chamber. The temperature was varied from -10°C to 50°C in 10°C increments. After a 1-hour soak time the output frequency was measured and compared to the 0.005% limit.

**Test Set-Up**

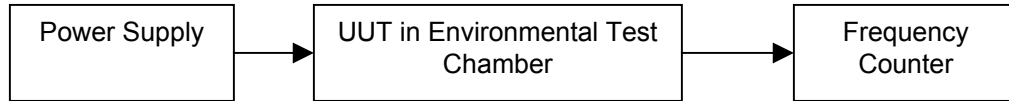

**Measurement Results**

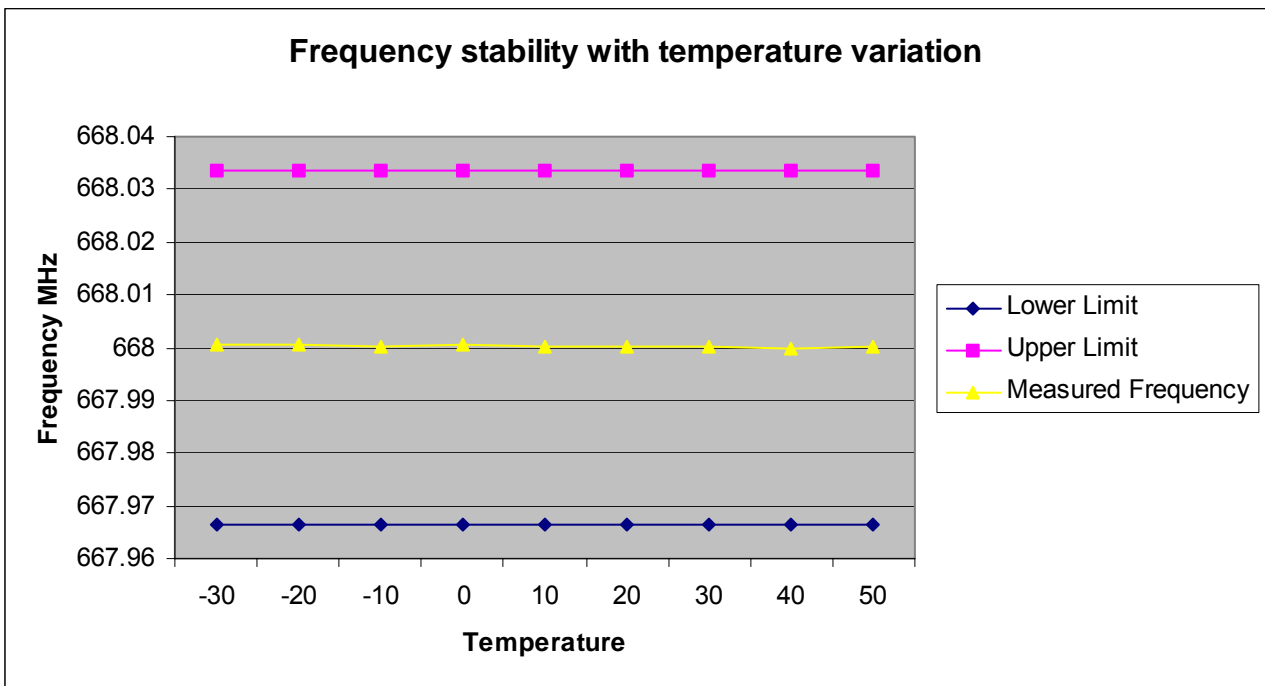

**Name of Test:** Frequency Stability (Voltage Variation)  
**Specification:** 2.1055(d)(2)  
**Test Equipment Utilized:** See Equipment List

**Test Date:** 5/9/2008

**Measurement Procedure**

The EUT was tested by varying the DC supply voltage from the nominal voltage of 9 VDC to the dropout voltage of 6.5 VDC. The output frequency was measured and compared to the 0.005% limit.

**Test Set-Up**

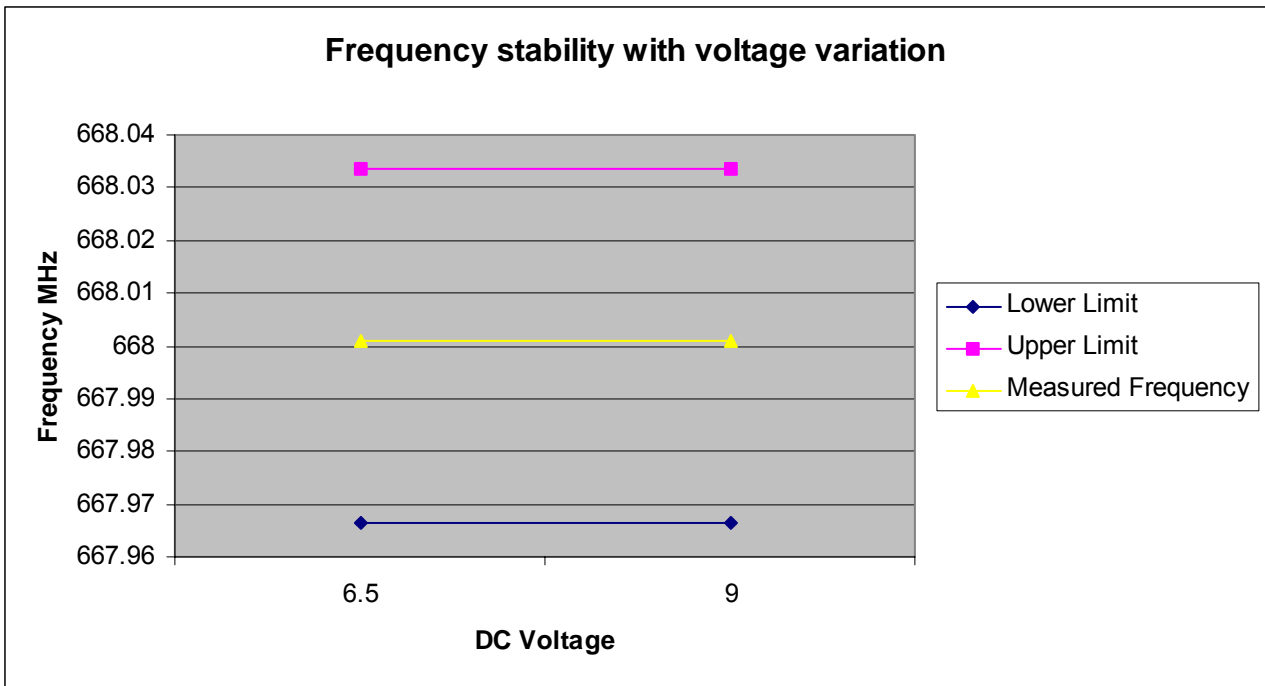
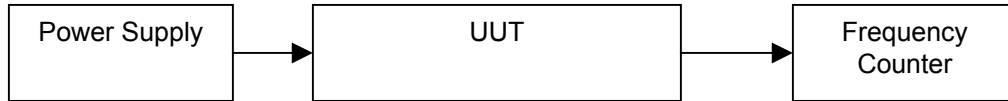



### Test Equipment Utilized

Asset#	Manufacturer	Model	Serial Number	Cal Cycle	Calibration Due
I00008	Kenwood	PR19-3A	5080154	When used	Verified
I00017	HP	8903A	2216A01753	12 mo.	1/24/2009
I00020	HP	8901A	2105A01087	12 mo.	1/24/2009
I00021	HP	8945A	2146A00159	N/A	Verified
I00027	Tenney	Tenney Jr	9083-76J-234	12 mo.	9/25/2008
I00031	HP	8656A	2402A06180	When used	Verified
I00033	HP	85462A	3625A00357	12 mo.	10/1//2008
I00034	HP	8546A	3448A00225	12 mo.	10/1/2008
I00048	HP	85662A	2511AD1467	12 mo.	8/18/2008
I00049	HP	8566B	2511AD1467	12 mo.	8/18/2008
I00050	HP	85685A	2510A00185	12 mo.	8/18/2008
I00051	HP	85650A	2521A00647	12 mo.	8/18/2008
I00054	HP	6286A	1612A02671	When used	Verified
I00055	HP	8447D	1726A01101	When used	Verified
I00062	HP	6842A	3531A00123	12 mo.	6/4/2008
I00088	EMCO Biconical	3109B	2336	24 mo.	10/16/2009
I00089	Aprel Log Periodic	2001	001500	24 mo.	10/19/2009
I00103	EMCO Horn	3115	9028-3925	36 mo.	10/4/2009
I00170	Lindgren	LG170	4999	When used	Verified
I00192	Solar Electronics	6741-1	841402	24 mo.	10/24/2008
I00207	HP	8753D	3410A08514	12 mo.	8/4/2008
I00231	Pasternak	PE7021-30dB		When used	Verified
I00244	FCC	50-25-2-01	2047	12 mo.	10/25/2007
I00250	S-5 Electronics	CDN	0250	When used	Verified
I00251	HP	53152A	US39270237	12 mo.	5/3/2008
I00252	Luthi	EM101	43773	24 mo.	10/24/2008
I00266	Rohde&Schwarz	SMT03	82611/005	When used	Verified
I00267	Schaffner	CBL611C	2910	24 mo.	11/6/2009
I00271	ARA	DRG-1181A	1176	36 mo.	3/6/2010
I00273	ARA	MWH-1826/B	1044	36 mo.	3/7/2010
I00275	EIN	440LA	231	When used	Verified
I00290	HP	8566B	2140A01231	12 mo.	8/7/2008
I00291	HP	85662A	2152A02970	12 mo.	8/7/2008
I00315	HP	9142-1N	063802	36 mo.	5/26/2008
I00318	HP	54502A	2934A00688	12 mo.	10/17/2008
I00321	HP	8901A	2239A02170	12 mo.	9/17/2008
I00324	HP	8903B	3011A09079	12 mo.	9/4/2008
I00325	Tektronix	TDS2021B	C010121	12 mo.	10/17/2008
I00331	HP	E4407B	MY45101313	12 mo.	10/31/2008

In addition to the above listed equipment standard RF connectors and cables were utilized in the testing of the described equipment. Prior to testing these components were tested to verify proper operation.

#### END OF TEST REPORT