

N/A

CHG NO		LTR	REVISIONS	DESCRIPTION	DATE	APPD
--------	--	-----	-----------	-------------	------	------

This drawing, written description or specification represents a proprietary product of TELEX, Lincoln, NE., and shall not be released, disclosed, nor duplicated without the written permission of TELEX

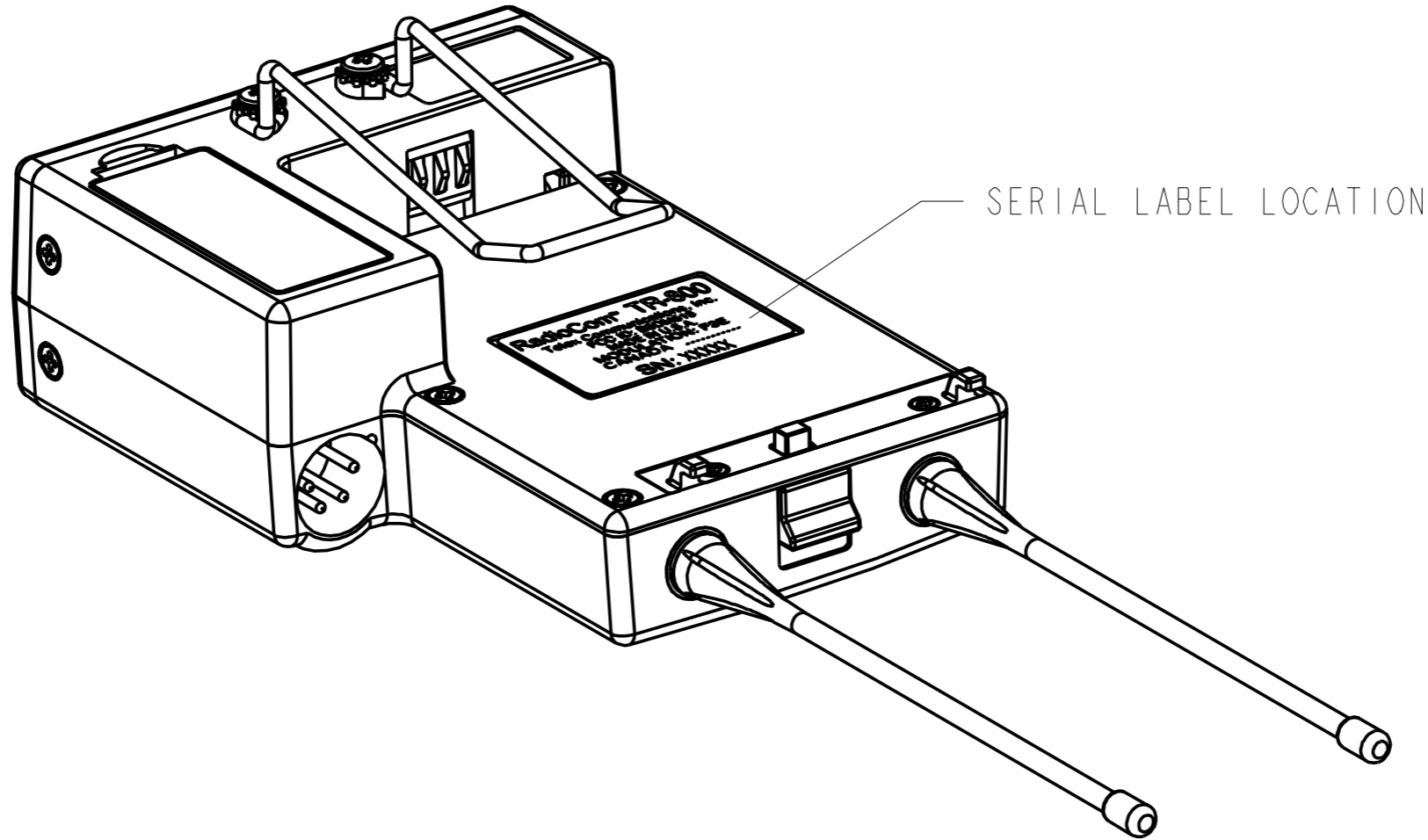

QTY	DESCRIPTION	ITEM	PART NO.	SPECIFICATION		
	UNSPECIFIED LIMITS OF TOLERANCE	DATE	06-DEC-02	<p style="text-align: center;">Telex® TELEX COMMUNICATIONS INC. Lincoln Nebraska U.S.A.</p>		
	DECIMAL:	DR BY	PSE			
	.X = ±.030 IN FRACTION:	CHK BY		<p style="text-align: center;">SERIAL LABEL LOCATION FOR THE TR-800</p>		
	.XX = ±.010 IN MACHINED	APPD.				
	.XXX = ±.005 IN. FINISH: 64 ✓	PROD.				
	ANGLES ±1°, BENDS ±2°	MATERIAL:	N/A	SIZE	CODE IDENT	DWG. NO.
	STRAIGHTNESS AND/OR			B	57010	N/A
	FLATNESS .005 IN./1 IN.			SCALE: NONE		
	CONCENTRICITY .010 TIR			SHEET: 1 OF 1		
	UNMARKED ANGLES, BENDS					
	AND INTERSECTIONS 90°					
NEXT ASSY.	USED ON					
APPLICATIONS						
	THREADS- EXT. CLASS 2A					
	INT. CLASS 2B					