



RADIO TEST REPORT

Test Report No. : 26KE0022-HO-D

Applicant : BROTHER INDUSTRIES, LTD.
Type of Equipment : Facsimile Machine
Model No. : MFC-845CW
FCC ID : B3Q8CAA19
Test standard : FCC Part 15 Subpart C
Section 15.207, Section 15.247: 2006
Test Result : Complied

1. This test report shall not be reproduced in full or partial, without the written approval of UL Apex Co., Ltd.
2. The results in this report apply only to the sample tested.
3. This equipment is in compliance with the above regulation.
4. The test results in this report are traceable to the national or international standards.

Date of test:

July 21 to August 8, 2006

Tested by:

T. Shimada

Takumi Shimada
Engineer of EMC Services

Approved by :

Hironobu Shimoji

Hironobu Shimoji
Group Leader of EMC Services

NVLAP[®]

NVLAP LAB CODE: 200572-0

This laboratory is accredited by the NVLAP LAB CODE 200572-0, U.S.A. The tests reported herein have been performed in accordance with its terms of accreditation.

*As for the range of Accreditation in NVLAP, you may refer to the WEB address, <http://ulapex.jp/emc/nvlap.htm>

UL Apex Co., Ltd.

Head Office EMC Lab.

4383-326 Asama-cho, Ise-shi, Mie-ken 516-0021 JAPAN

Telephone : +81 596 24 8116

Facsimile : +81 596 24 8124

MF060b(14.06.06)

CONTENTS	PAGE
SECTION 1: Client information	3
SECTION 2: Equipment under test (E.U.T.)	3
SECTION 3: Test specification, procedures & results	4
SECTION 4: Operation of E.U.T. during testing	7
SECTION 5: Conducted Emission	9
SECTION 6: Spurious Emission	10
SECTION 7: Bandwidth	11
SECTION 8: Maximum Peak Output Power	11
SECTION 9: Carrier Frequency Separation	11
SECTION 10: Number of Hopping Frequency	11
SECTION 11: Dwell time	11
APPENDIX 1: Photographs of test setup	12
Conducted Emission.....	12
Spurious Emission (Radiated).....	13
Worst Case Antenna Position (0deg.:Horizontal / 90deg.:Vertical).....	14
APPENDIX 2: Data of EMI test	15
Conducted Emission.....	15
Carrier Frequency Separation.....	19
20dB Bandwidth.....	21
Number of Hopping Frequency.....	23
Dwell time.....	25
Maximum Peak Output Power.....	27
Radiated Spurious Emission.....	28
Conducted Spurious Emission.....	34
APPENDIX 3: Test instruments	41

SECTION 1: Client information

Company Name	BROTHER INDUSTRIES, LTD.
Brand name	brother
Address	1-1-1, Kawagishi, Mizuho-ku, Nagoya 467-8562, Japan
Telephone Number	+81-52-824-2348
Facsimile Number	+81-52-824-2734
Contact Person	Katsuhiko Sato

SECTION 2: Equipment under test (E.U.T.)

2.1 Identification of E.U.T.

Type of Equipment	:	Facsimile Machine
Model No.	:	MFC-845CW
Serial No.	:	0001
Rating	:	AC100-120V
Country of Manufacture	:	China
Receipt Date of Sample	:	July 18, 2006
Condition of EUT	:	Engineering prototype (Not for Sale: This sample is equivalent to mass-produced items.)
Modification of EUT	:	No modification by the test lab.

2.2 Product Description
2.2.1 General Information

Feature of EUT	EUT is a compound device with the function of FAX, Scanner, Copy, Printer, and cordless phone.
Operation Clock	13.824MHz

2.2.2 Radio Specification

Equipment Type	Transceiver
Frequency band	Low Channel = 5725.809328 MHz High Channel = 5848.889420 MHz
Bandwidth & Channel spacing	Bandwidth: 1MHz Channel spacing: 891.871kHz
Type of Modulation	FHSS
Antenna Type	1/4 lambda dipole antenna (Installed outside) *1) Wire antenna (Installed inside)
Antenna Connector Type	N/A
Antenna Gain	0.2 dBi(Max) : 1/4 lambda dipole antenna *1) 3.7 dBi (Max) : Wire antenna
Power Supply (inner/to RF Module)	DC +3.3V
Method of Frequency Generation	Synthesizer

*1) This antenna is used in priority to another antenna for this EUT system.

SECTION 3: Test specification, procedures & results

3.1 Test Specification

Test Specification : FCC Part15 Subpart C : 2006
Title : FCC 47CFR Part15 Radio Frequency Device Subpart C Intentional Radiators
Section 15.207 Conducted limits : 2006
Section 15.247 Operation within the bands 902-928MHz,
2400-2483.5MHz, and 5725-5850MHz : 2006

FCC 15.31 (e)

This EUT provides stable voltage(DC3.3V) constantly to RF Module regardless of input voltage. Therefore, this EUT complies with the requirement.

FCC Part 15.203 Antenna requirement

It is impossible for end users to replace the antenna, because the antenna is mounted inside of the EUT. Therefore, the equipment complies with the antenna requirement of Section 15.203.

3.2 Procedures and results

[FHSS]

No.	Item	Test Procedure	Specification	Remarks	Deviation	Worst Margin*0)	Results
1	Conducted emission	FCC: ANSI C63.4:2003 7. AC powerline conducted emission measurements	FCC: Section 15.207	-	N/A	1.7dB 0.51443MHz (AV)	Complied
2	Carrier Frequency Separation	FCC: ANSI C63.4:2003 13. Measurement of intentional radiators	FCC: Section 15.247(a)(1)	Conducted	N/A	See data.	Complied
3	20dB Bandwidth	FCC: ANSI C63.4:2003 13. Measurement of intentional radiators	FCC: Section 15.247(a)(1)(ii)	Conducted	N/A		Complied
4	Number of Hopping Frequency	FCC: ANSI C63.4:2003 13. Measurement of intentional radiators	FCC: Section 15.247(a)(1)(ii)	Conducted	N/A		Complied
5	Dwell time	FCC: ANSI C63.4:2003 13. Measurement of intentional radiators	FCC: Section 15.247(a)(1)(ii)	Conducted	N/A		Complied
6	Maximum Peak Output Power	FCC: ANSI C63.4:2003 13. Measurement of intentional radiators	FCC: Section 15.247(b)(1)	Conducted	N/A		Complied
7	Band Edge Compliance	FCC: ANSI C63.4:2003 13. Measurement of intentional radiators	FCC: Section 15.247(d)	Conducted	N/A		Complied
8	Spurious Emission	FCC: ANSI C63.4:2003 13. Measurement of intentional radiators	FCC: Section 15.247(d)	Conducted/ Radiated	N/A	3.3dB 22902.7MHz (PK)	Complied

Note: UL Apex's EMI Work Procedures No.QPM05 and QPM15.
*0) The result is rounded off to the second decimal place. Therefore, there may be 0.1 difference for the result.

*These tests were also referred to FCC Public Notice DA 00-705 "Guidance on Measurement for Frequency Hopping Spread Spectrum Systems".

*These tests were performed without any deviations from test procedure except for additions or exclusions.

3.3 Additions or deviations to standards

No addition, deviation, nor exclusion has been made from standards.

3.4 Uncertainty

Conducted Emission

The measurement uncertainty (with a 95% confidence level) for this test is ± 2.6 dB.
The data listed in this report meets the limits unless the uncertainty is taken into consideration.

Spurious Emission (Radiated)

The measurement uncertainty (with a 95% confidence level) for this test using Biconical antenna is ± 4.59 dB(3m)/
 ± 4.58 dB(10m).

The measurement uncertainty (with a 95% confidence level) for this test using Logperiodic antenna is ± 4.62 dB(3m)/
 ± 4.60 dB(10m).

The measurement uncertainty (with a 95% confidence level) for this test using Horn antenna is ± 5.27 dB.
The data listed in this report meets the limits unless the uncertainty is taken into consideration.

Other test except Conducted Emission and Spurious Emission (Radiated)

The measurement uncertainty (with a 95% confidence level) for this test is ± 3.0 dB.

3.5 Test Location

UL Apex Co., Ltd. Head Office EMC Lab. *NVLAP Lab. code: 200572-0

4383-326 Asama-cho, Ise-shi, Mie-ken 516-0021 JAPAN

Telephone : +81 596 24 8116 Facsimile : +81 596 24 8124

	FCC Registration Number	IC Registration Number	Width x Depth x Height (m)	Size of reference ground plane (m) / horizontal conducting plane	Other rooms
No.1 semi-anechoic Chamber	313583	IC4247A	19.2 x 11.2 x 7.7m	7.0 x 6.0m	Preparation room
No.2 semi-anechoic Chamber	655103	IC4247A-2	7.5 x 5.8 x 5.2m	4.0 x 4.0m	-
No.3 semi-anechoic Chamber	148738	IC4247A-3	12.0 x 8.5 x 5.9m	6.8 x 5.75m	
No.3 shielded room	-	-	4.0 x 6.0 x 2.7m	N/A	-
No.4 semi-anechoic Chamber	134570	IC4247A-4	12.0 x 8.5 x 5.9m	6.8 x 5.75m	-
No.4 shielded room	-	-	4.0 x 6.0 x 2.7m	N/A	-
No.5 shielded room	-	-	6.0 x 6.0 x 3.9m	N/A	-
No.6 shielded Room	-	-	4.0 x 4.5 x 2.7m	N/A	-
No.6 measurement Room	-	-	4.75 x 5.4 x 3.0m	N/A	-
No.7 shielded room	-	-	4.7 x 7.5 x 2.7m	4.7 x 7.5m	-
No.8 measurement Room	-	-	3.1 x 5.0 x 2.7m	N/A	-

* Size of vertical conducting plane (for Conducted Emission test) : 2.0 x 2.0m for No.1, No.2, No.3 and No.4 semi-anechoic chambers and No.7 shielded room.

3.6 Test set up, Test instruments and Data of EMI

Refer to APPENDIX 1 to 3.

UL Apex Co., Ltd.

Head Office EMC Lab.

4383-326 Asama-cho, Ise-shi, Mie-ken 516-0021 JAPAN

Telephone : +81 596 24 8116

Facsimile : +81 596 24 8124

MF060b(14.06.06)

SECTION 4: Operation of E.U.T. during testing

4.1 Operating Modes

The mode used for test : **[For Antenna terminal conducted test]**

--Hopping ON

Communication mode *1)

*1) MFC-845CW communicates with Digital Cordless Handset on wireless.

-Hopping OFF

Transmitting mode

Low Channel (ch 1) : 5725.809328MHz

Mid Channel (ch 71) : 5788.240269MHz

High Channel (ch 139) : 5848.889420MHz

[For Conducted emission test and Radiated emission test]

-Hopping OFF

Transmitting mode

Low Channel (ch 1) : 5725.809328MHz

Mid Channel (ch 71) : 5788.240269MHz

High Channel (ch 139) : 5848.889420MHz

Remarks: Test was not performed at AFH mode, because the decrease of number of channel (min: 20ch) at AFH mode does not influence on the output power and bandwidth of the EUT.

However, the limit level 125mW of AFH mode was used for the test.

UL Apex Co., Ltd.

Head Office EMC Lab.

4383-326 Asama-cho, Ise-shi, Mie-ken 516-0021 JAPAN

Telephone : +81 596 24 8116

Facsimile : +81 596 24 8124

MF060b(14.06.06)

4.2 Configuration and peripherals

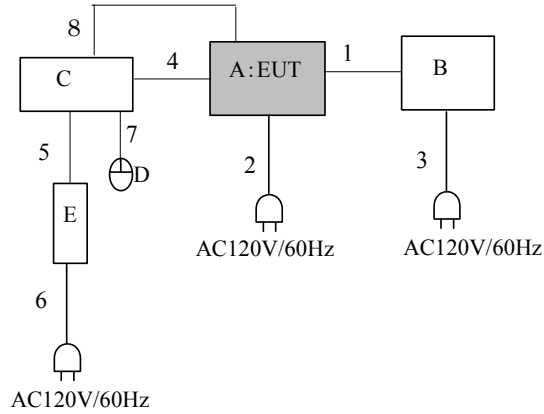

* Cabling and setup were taken into consideration and test data was taken under worst case conditions.

Description of Support equipment

No.	Item	Model number	Serial number	Manufacturer	Remarks
A	Facsimile Machine	MFC-845CW	0001	Brother	EUT
B	FAX equipment	FQ-70	17104455	Sharp	-
C	Notebook PC	PC-MJ720M	1V024403	Sharp	-
D	PS/2 Mouse	X06-08477	-	Microsoft	-
E	AC Adaptor	EA-RJ1V	NLD0107025900	Sharp	-

List of cables used

No.	Name	Length (m)	Shield	
			Cable	Connector
1	TEL Cable	1.5	Unshielded	Unshielded
2	AC Cable	1.8	Unshielded	Unshielded
3	AC Cable	1.8	Unshielded	Unshielded
4	USB Cable	3.0	Shielded	Shielded
5	DC Cable	1.8	Unshielded	Unshielded
6	AC Cable	1.8	Unshielded	Unshielded
7	Mouse Cable	2.0	Unshielded	Unshielded
8	LAN Cable	1.0	Unshielded	Unshielded

UL Apex Co., Ltd.

Head Office EMC Lab.

4383-326 Asama-cho, Ise-shi, Mie-ken 516-0021 JAPAN

Telephone : +81 596 24 8116

Facsimile : +81 596 24 8124

MF060b(14.06.06)

SECTION 5: Conducted Emission

Test Procedure and conditions

EUT was placed on a wooden table of nominal size, 1m by 1.5m, raised 80cm above the conducting ground plane. The rear of tabletop was located 40cm to the vertical conducting plane. The rear of EUT, including peripherals aligned and flushed with rear of tabletop. All other surfaces of tabletop were at least 80cm from any other grounded conducting surface. EUT was located 80cm from a Line Impedance Stabilization Network (LISN)/ Artificial mains Network (AMN) and excess AC cable was bundled in center.

For the tests on EUT with other peripherals (as a whole system)

I/O cable and AC cables that were connected to the peripherals were bundled in center. They were folded back and forth forming a bundle 30cm to 40cm long and were hanged at a 40cm height to the ground plane. All unused 50ohm connectors of the LISN(AMN) were resistivity terminated in 50ohm when not connected to the measuring equipment.

The AC Mains Terminal Continuous disturbance Voltage has been measured with the EUT in a Semi Anechoic Chamber or a Measurement Room.

The EUT was connected to a LISN (AMN).

An overview sweep with peak detection has been performed.

Detector : CISPR quasi-peak and average detector (IF BW 9 kHz)
Measurement range : 0.15-30MHz
Test data : APPENDIX 3
Test result : Pass

Date: August 8, 2006

Test engineer: Takumi Shimada

UL Apex Co., Ltd.

Head Office EMC Lab.

4383-326 Asama-cho, Ise-shi, Mie-ken 516-0021 JAPAN

Telephone : +81 596 24 8116

Facsimile : +81 596 24 8124

MF060b(14.06.06)

SECTION 6: Spurious Emission

[Conducted]

Test Procedure

The Out of Band Emission was measured with a spectrum analyzer connected to the antenna port.

Test data : APPENDIX 2

Test result : Pass

[Radiated]

Test Procedure

EUT was placed on a urethane platform of nominal size, 1.5m by 1.0m, raised 80cm above the conducting ground plane. The Radiated Electric Field Strength intensity has been measured in a Semi Anechoic Chamber with a ground plane and at a distance of 3m(Below 10GHz) and 1m(Upper 10GHz).

The height of the measuring varied between 1 and 4m and EUT was rotated a full revolution in order to obtain the maximum value of the electric field intensity.

The measurements were performed for both vertical and horizontal antenna polarization with the Test Receiver, or the Spectrum Analyzer (in linear mode).

The test was made with the detector (RBW/VBW) in the following table.

When using Spectrum analyzer, the test was made with adjusting span to zero by using peak hold.

In any 100kHz bandwidth outside the frequency band in which the spread spectrum intentional radiator is operating, the radio frequency power that is produced by the intentional radiator confirmed 20dB below that in the 100kHz bandwidth within the band that contains the highest level of the desired power, based on a radiated measurement.

20dBc was applied to the frequency over the limit of FCC 15.209 and outside the restricted band of FCC15.205.

Frequency	Below 1GHz	Above 1GHz
Instrument used	Test Receiver / Spectrum Analyzer	Spectrum Analyzer
Detector	QP: BW 120kHz(T/R)	PK: RBW:1MHz/VBW: 1MHz
IF Bandwidth	20dBc : RBW: 100kHz VBW: 300kHz (S/A)	AV: RBW:1MHz/VBW:10Hz 20dBc : RBW:100kHz/VBW:300kHz

The test was made on EUT at the normal use position.

Test data : APPENDIX 2

Test result : Pass

Date: August 5, 2006

Test engineer: Takumi Shimada

UL Apex Co., Ltd.

Head Office EMC Lab.

4383-326 Asama-cho, Ise-shi, Mie-ken 516-0021 JAPAN

Telephone : +81 596 24 8116

Facsimile : +81 596 24 8124

MF060b(14.06.06)

SECTION 7: Bandwidth

Test Procedure

The bandwidth was measured with a spectrum analyzer connected to the antenna port.

Test data : APPENDIX 2
Test result : Pass

SECTION 8: Maximum Peak Output Power

Test Procedure

The Maximum Peak Output Power was measured with a power meter (tested bandwidth: 50MHz) connected to the antenna port.

Test data : APPENDIX 2
Test result : Pass

SECTION 9: Carrier Frequency Separation

Test Procedure

The carrier frequency separation was measured with a spectrum analyzer connected to the antenna port.

Test data : APPENDIX 2
Test result : Pass

SECTION 10: Number of Hopping Frequency

Test Procedure

The Number of Hopping Frequency was measured with a spectrum analyzer connected to the antenna port.

Test data : APPENDIX 2
Test result : Pass

SECTION 11: Dwell time

Test Procedure

The Dwell time was measured with a spectrum analyzer connected to the antenna port.

Test data : APPENDIX 2
Test result : Pass

APPENDIX 2: Data of EMI test

Conducted Emission

DATA OF CONDUCTED EMISSION TEST

UL Apex Co., Ltd. Head Office EMC Lab. No.2 Semi-Anechoic Chamber
 Date : 2006/08/08 11:05:27

Applicant	: BROTHER INDUSTRIES, LTD.	Report No.	: 26KE0022-HO
Kind of EUT	: Facsimile machine	Power	: AC 120V 60Hz
Model No.	: MFC-845CW	Temp./Humi.	: 24 deg. C / 59%
Serial No.	: 0001	Operator	: Takumi Shimada

Mode / Remarks : Tx ch1 (5725.809328MHz)

LIMIT : FCC15C §15.207 (QP) / RSS-Gen / RSS-210
 FCC15C §15.207 (AV) / RSS-Gen / RSS-210

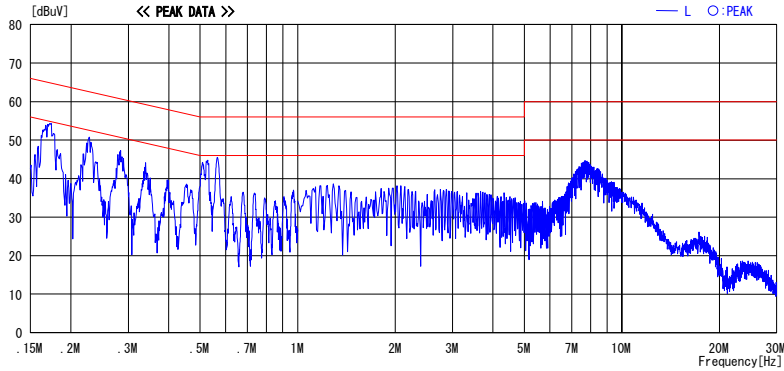
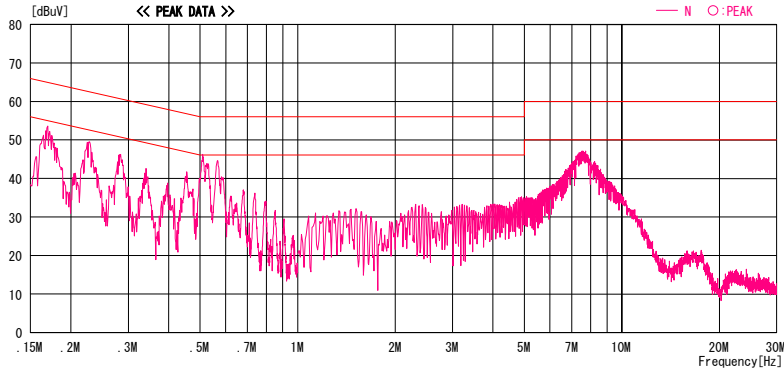

CHART: WITH FACTOR. Peak hold data. Data is uncorrected. CALCULATION: RESULT=READING+C.F.(LISN LOSS+CABLE LOSS)
 Except for the above table: adequate margin data below the limits.

Conducted Emission

DATA OF CONDUCTED EMISSION TEST

UL Apex Co., Ltd. Head Office EMC Lab. No.2 Semi-Anechoic Chamber
 Date : 2006/08/08 11:37:28

Applicant : BROTHER INDUSTRIES, LTD.	Report No. : 26KE0022-HO
Kind of EUT : Facsimile machine	Power : AC 120V 60Hz
Model No. : MFC-845CW	Temp./Humi. : 24 deg. C / 59%
Serial No. : 0001	Operator : Takumi Shimada

Mode / Remarks : Tx ch71 (5788.240469MHz)

LIMIT : FCC15C §15.207 (QP) / RSS-Gen / RSS-210
 FCC15C §15.207 (AV) / RSS-Gen / RSS-210

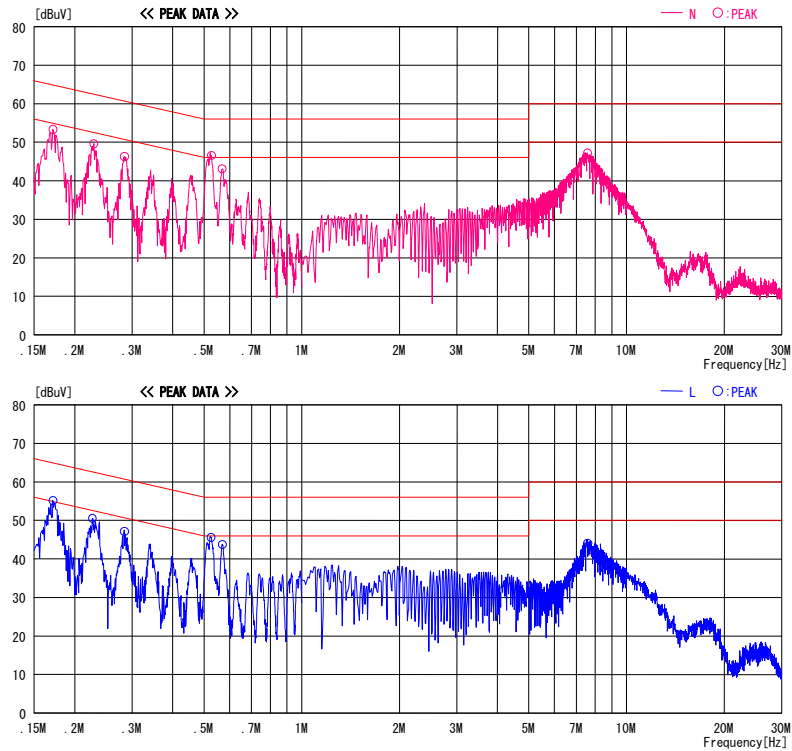

CHART: WITH FACTOR. Peak hold data. Data is uncorrected. CALCULATION: RESULT=READING+C.F (LISN LOSS+CABLE LOSS)
 Except for the above table : adequate margin data below the limits.

Conducted Emission

DATA OF CONDUCTED EMISSION TEST

UL Apex Co., Ltd. Head Office EMC Lab. No.2 Semi-Anechoic Chamber
 Date : 2006/08/08 11:37:28

Applicant : BROTHER INDUSTRIES, LTD. Report No. : 26KE0022-HO
 Kind of EUT : Facsimile machine Power : AC 120V 60Hz
 Model No. : MFC-845CW Temp./Humi. : 24 deg. C / 59%
 Serial No. : 0001 Operator : Takumi Shimada

Mode / Remarks : Tx ch71 (5788.240469MHz)

LIMIT : FCC15C § 15.207 (QP) / RSS-Gen / RSS-210
 FCC15C § 15.207 (AV) / RSS-Gen / RSS-210

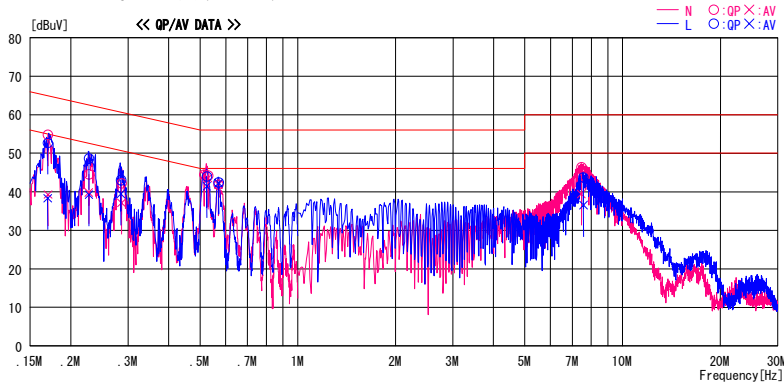

Frequency [MHz]	Reading Level		Corr. Factor	Results		Limit		Margin		Phase
	QP [dBuV]	AV [dBuV]		QP [dBuV]	AV [dBuV]	QP [dBuV]	AV [dBuV]	QP [dB]	AV [dB]	
0.16987	52.5	38.1	0.2	52.7	38.3	65.0	55.0	12.3	16.7	L
0.17009	54.6	39.1	0.2	54.8	39.3	65.0	55.0	10.2	15.7	N
0.22758	48.3	38.8	0.4	48.7	39.2	62.5	52.5	13.8	13.3	L
0.22733	44.1	39.5	0.4	44.5	39.9	62.5	52.5	18.0	12.6	N
0.28638	41.8	36.7	0.4	42.2	37.1	60.6	50.6	18.4	13.5	N
0.28510	42.7	39.1	0.4	43.1	39.5	60.7	50.7	17.6	11.2	L
0.51443	44.0	43.9	0.4	44.4	44.3	56.0	46.0	11.6	1.7	N
0.52999	43.8	43.2	0.4	44.2	43.6	56.0	46.0	11.8	2.4	N
0.52461	43.6	41.0	0.4	44.0	41.4	56.0	46.0	12.0	4.6	L
0.57000	41.5	41.4	0.4	41.9	41.8	56.0	46.0	14.1	4.2	N
0.57059	42.0	41.9	0.4	42.4	42.3	56.0	46.0	13.6	3.7	L
7.46898	45.2	38.2	1.2	46.4	39.4	60.0	50.0	13.6	10.6	N
7.58158	42.5	35.3	1.2	43.7	36.5	60.0	50.0	16.3	13.5	L

CHART: WITH FACTOR. Peak hold data. Data is uncorrected. CALCULATION: RESULT=READING+C.F (LISN LOSS+CABLE LOSS)
 Except for the above table : adequate margin data below the limits.

Conducted Emission

DATA OF CONDUCTED EMISSION TEST

UL Apex Co., Ltd. Head Office EMC Lab. No. 2 Semi-Anechoic Chamber
 Date : 2006/08/08 11:18:17

Applicant : BROTHER INDUSTRIES, LTD.	Report No. : 26KE0022-HO
Kind of EUT : Facsimile machine	Power : AC 120V 60Hz
Model No. : MFC-845GW	Temp./Humi. : 24 deg. C / 59%
Serial No. : 0001	Operator : Takumi Shimada

Mode / Remarks : Tx ch139 (5848.889420MHz)

LIMIT : FCC15C §15.207 (QP) / RSS-Gen / RSS-210
 FCC15C §15.207 (AV) / RSS-Gen / RSS-210

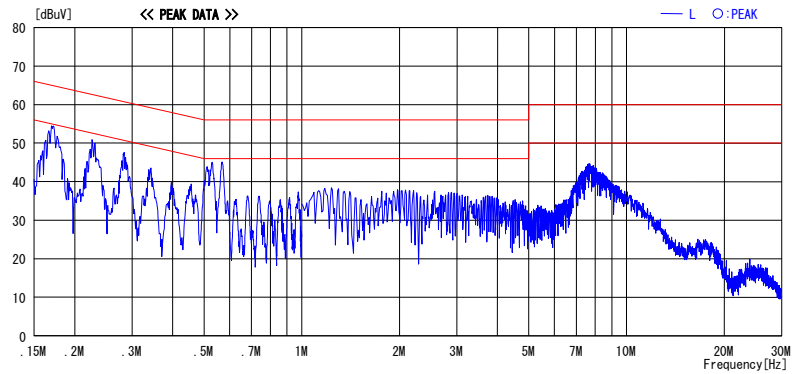
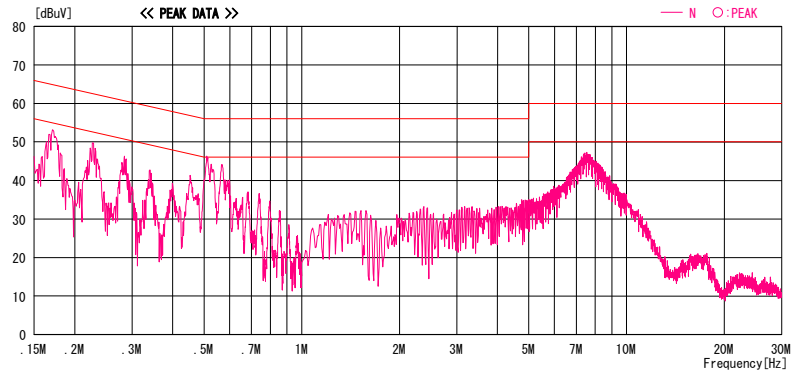

CHART: WITH FACTOR, Peak hold data. Data is uncorrected. CALCULATION: RESULT=READING+C.F (L1SN LOSS+CABLE LOSS)
 Except for the above table : adequate margin data below the limits.

Carrier Frequency Separation

UL Apex Co., Ltd.
Head Office EMC Lab. No.1 Preparation Room

COMPANY : BROTHER INDUSTRIES LTD. REGULATION : FCC Part15 Subpart C 15.247(a)(1)
EQUIPMENT : Facsimile Machine TEST DISTANCE : -
MODEL : MFC-845CW DATE : 07/21/2006
S/ N : 0001 TEMPERATURE : 24deg.C
POWER : AC120V /60Hz HUMIDITY : 70%
MODE : Tx(Hopping on) ENGINEER : Takumi Shimada

Ch	Freq. [MHz]	Channel separation [MHz]	Limit [MHz]
Low	5725.8	1.787	>0.720 (20dB Bandwidth or 25[kHz])(whichever is greater)
Mid	5788.2	1.773	>0.705 (20dB Bandwidth or 25[kHz])(whichever is greater)
High	5848.9	0.887	>0.767 (20dB Bandwidth or 25[kHz])(whichever is greater)

The following table shows the hopping sequence.

As for the detail of Frequency separation, please refer to “FCC Submission For 5.8 GHz FHSS System”, Clause 3, Section 3.2. (Theory of operation 3. pdf)

APPENDIX D – LOGICAL TO PHYSICAL MAPPING TABLE

The following table is the logical to physical mapping table, as detailed in section 3.2.3.

	0	1	2	3	4	5	6	7	8	9
0	1	3	5	7	9	11	13	15	17	19
10	21	23	25	27	29	31	33	35	37	39
20	41	43	45	47	49	51	53	55	57	59
30	61	63	65	67	69	71	73	75	77	79
40	81	83	85	87	89	91	93	95	97	99
50	101	103	105	107	109	111	113	115	117	119
60	121	123	125	127	129	130	131	132	133	134
70	135	136	137	138	139					

Carrier Frequency Separation

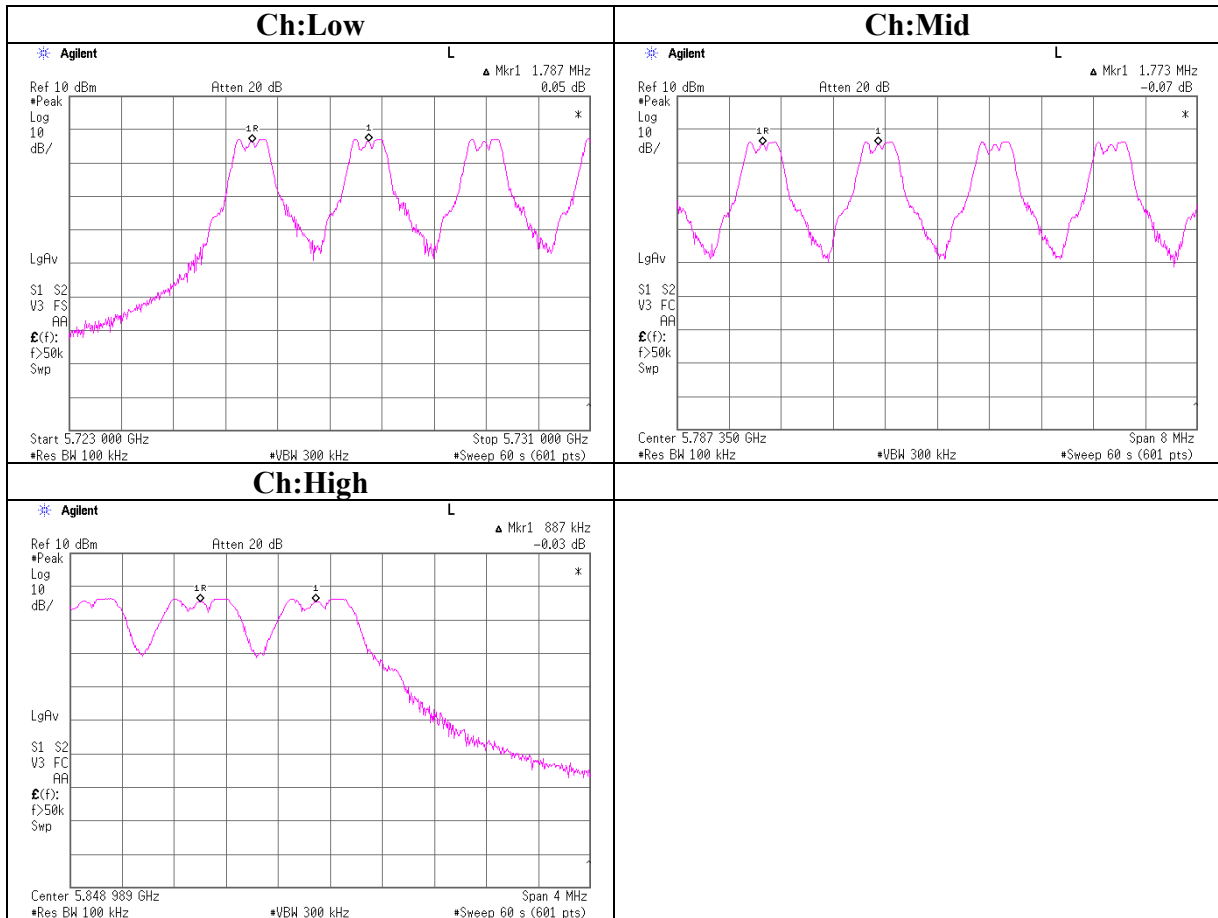

20dB Bandwidth

UL Apex Co., Ltd.
Head Office EMC Lab. No.1 Preparation Room

COMPANY : BROTHER INDUSTRIES LTD. REGULATION : FCC Part15 Subpart C 15.247(a)(1)
EQUIPMENT : Fascimile Machine TEST DISTANCE : -
MODEL : MFC-845CW DATE : 07/21/2006
S/ N : 0001 TEMPERATURE : 24deg.C
POWER : AC120V / 60Hz HUMIDITY : 70%
MODE : Tx (Hopping off) ENGINEER : Takumi Shimada

Ch	Freq. [MHz]	20dB Bandwidth [MHz]	Limit [MHz]
Low	5725.809328	0.720	-
Mid	5788.240269	0.705	-
High	5848.889420	0.767	-

20dB Bandwidth

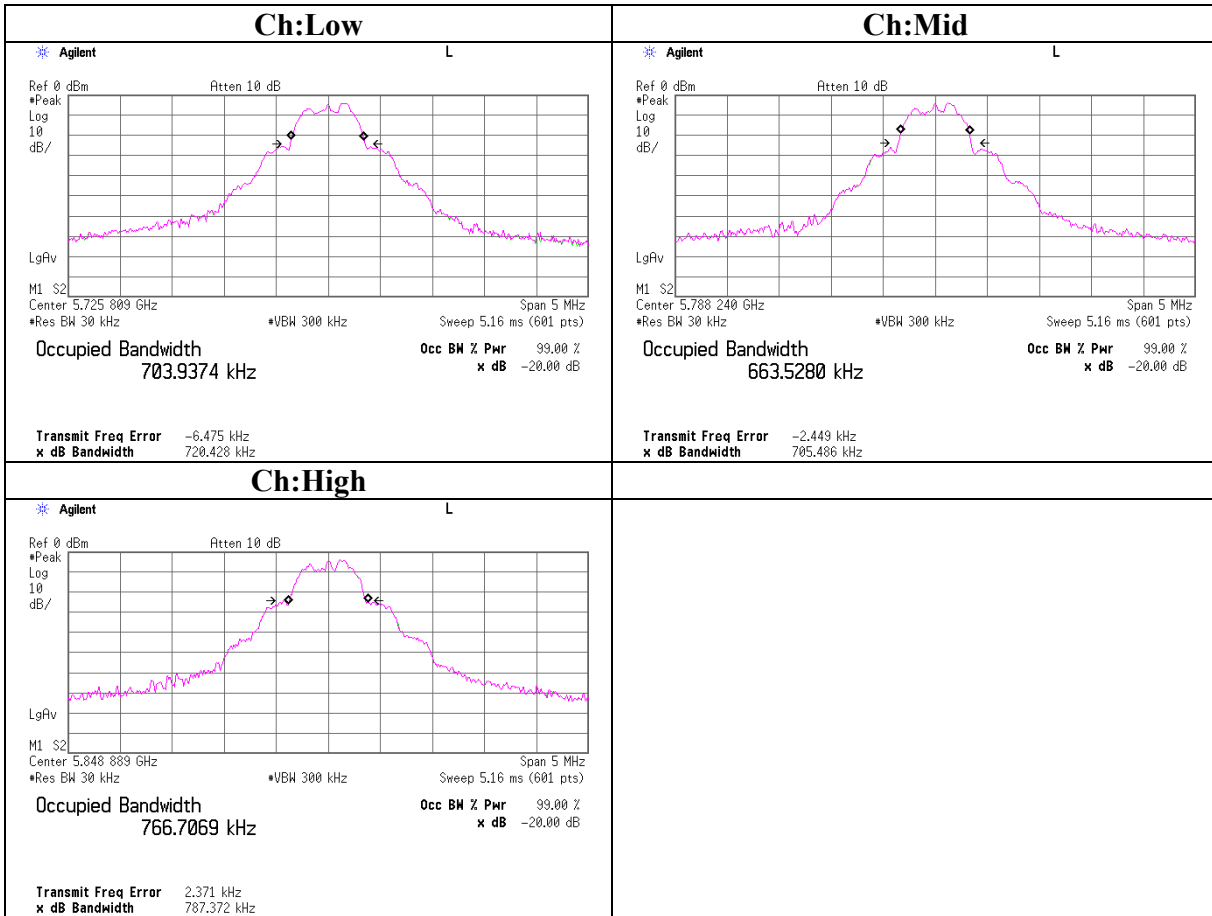

Number of Hopping Frequency

UL Apex Co., Ltd.
Head Office EMC Lab. No.1 Preparation Room

COMPANY : BROTHER INDUSTRIES LTD. REGULATION : FCC Part15 Subpart C 15.247(a)(1)(iii)
EQUIPMENT : Fascimile Machine TEST DISTANCE : -
MODEL : MFC-845CW DATE : 07/21/2006
S/ N : 0001 TEMPERATURE : 24deg.C
POWER : AC120V / 60Hz HUMIDITY : 70%
MODE : Tx (Hopping on) ENGINEER : Takumi Shimada

Mode	Number of channel	Limit
	[time]	[time]
Tx(Hopping on)	75	≥ 75

Number of Hopping Frequency

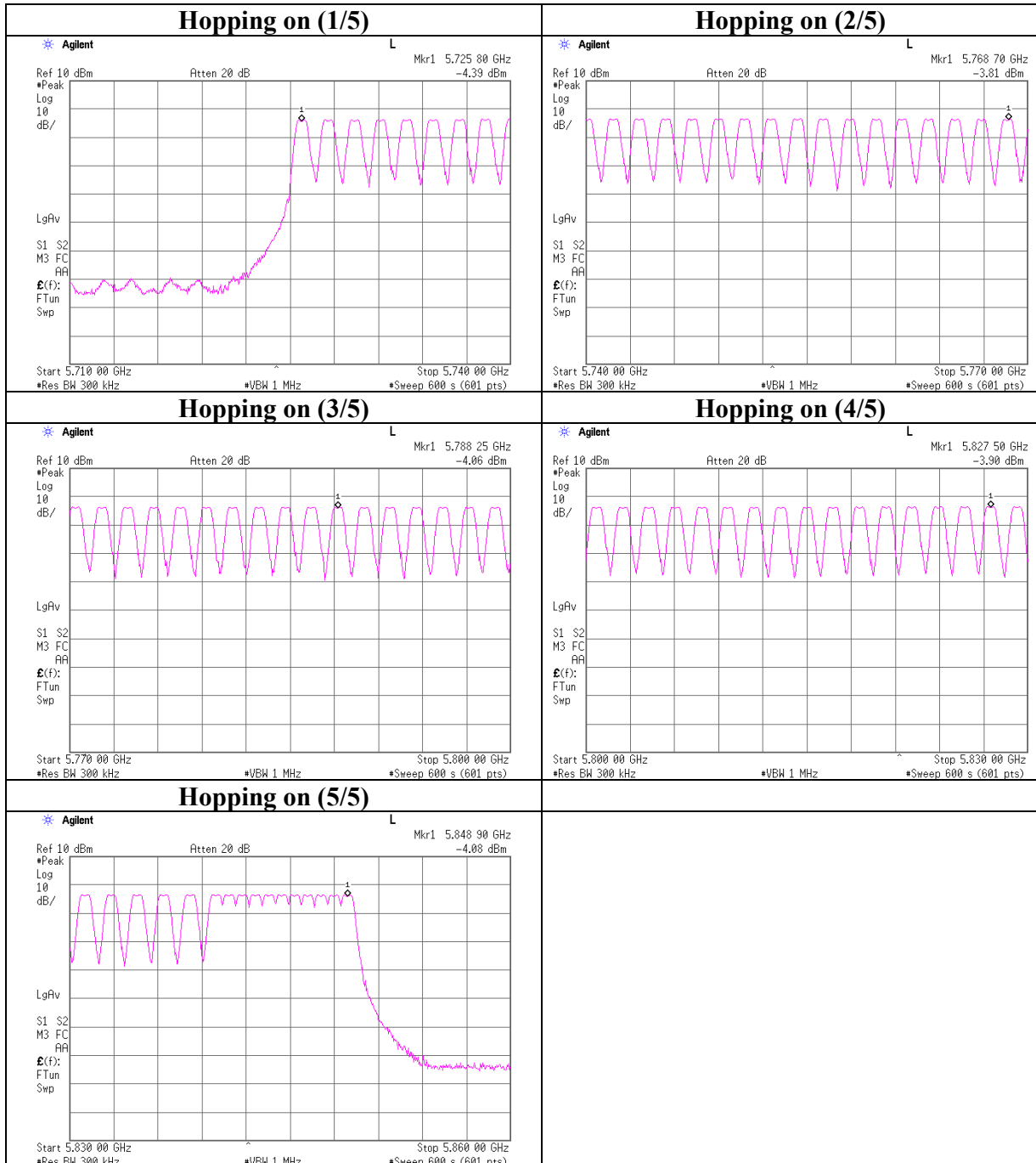

Dwell time

<p>COMPANY : BROTHER INDUSTRIES LTD. EQUIPMENT : Fascimile Machine MODEL : MFC-845CW S/ N : 0001 POWER : AV120V 60Hz MODE : Tx(Hopping on)</p>	<p>UL Apex Co., Ltd. Head Office EMC Lab. No.1 Preparation Room Head Office EMC Lab. No.6 Shielded Room REGULATION : FCC Part15 Subpart C 15.247(a)(1)(ii) TEST DISTANCE : - DATE : 07/21/2006 07/25/2006 TEMPERATURE : 25deg.C HUMIDITY : 67% ENGINEER : Takumi Shimada</p>
---	--

DUMMY BEARER

Mode	Number of transmission in a 30 sec	Length of transmission time [msec]	Result [msec]	Limit [msec]
Hopping on (M-ch)	39 times / 30sec	0.316	12.324	400

TRAFFIC BEARER

Mode	Number of transmission in a 30 sec	Length of transmission time [msec]	Result [msec]	Limit [msec]
Hopping on (M-ch)	39 times / 30sec	1.040	40.560	400

DUMMY BEARER Dwell Time + TRAFFIC BEARER Dwell Time

Mode	Dwell Time [msec]	Limit [msec]
Hopping on (M-ch)	52.884	400.000

The dummy bearer is usually separate to the traffic bearers, i.e. they are on different slots. In the case that 4 traffic bearers are required (the maximum number that can be supported by the FP) then one of the traffic bearers will also take over the responsibilities of the dummy bearer. In the remainder of the document this shall be referred to as a 'combined dummy/traffic bearer'. (From Clause 2.4 of Section 2 in FCC Submission For 5.8 GHz FHSS System)

The following diagram shows the down-link transmission of a traffic bearer; the up-link transmission is in slot 1.

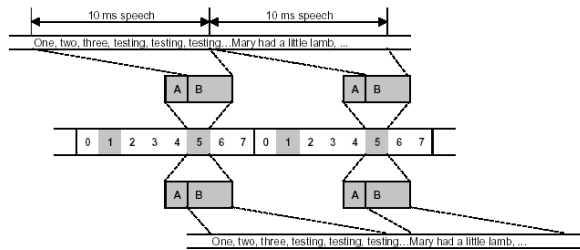

The following diagram shows a dummy bearer transmission. Note, that it uses only a down-link slot and the A-field of the packet.

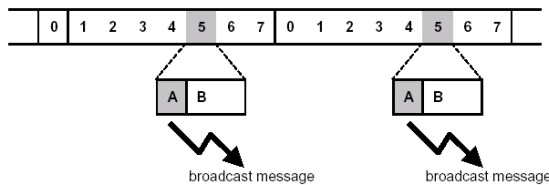

Dwell time

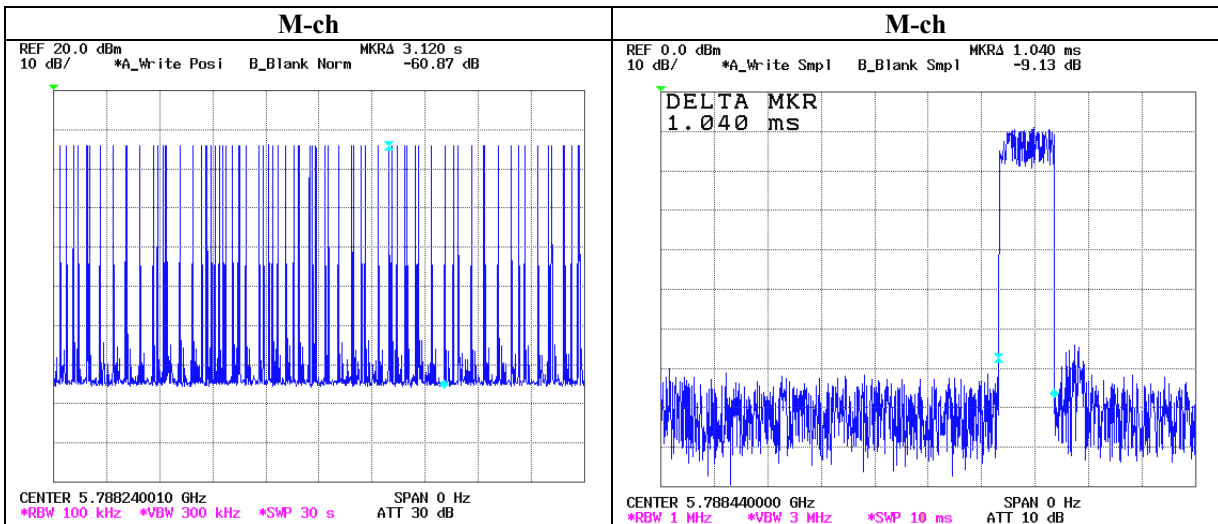
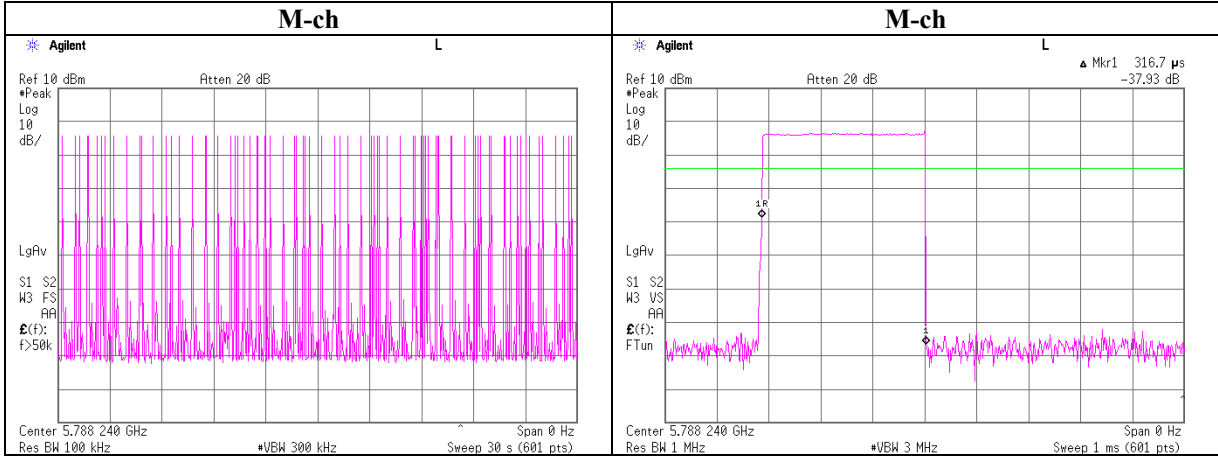

Maximum Peak Output Power

UL Apex Co., Ltd.
Head Office EMC Lab. No.1 Preparation Room

COMPANY	: BROTHER INDUSTRIES LTD.	REGULATION	: FCC Part15 Subpart C 15.247(b)(1)
EQUIPMENT	: Facsimile Machine	TEST DISTANCE	: -
MODEL	: MFC-845CW	DATE	: 07/21/2006
S/ N	: 0001	TEMPERATURE	: 24deg.C
POWER	: AC 120V / 60Hz	HUMIDITY	: 70%
MODE	: Tx(Hopping Off)	ENGINEER	: Takumi Shimada

Ch	Freq. [MHz]	P/M Reading [dBm]	Cable Loss [dB]	Atten. [dB]	Result		Limit		Margin [dB]
					[dBm]	[mW]	[dBm]	[mW]	
Low	5725.809328	-2.89	1.05515	20.24	18.41	69.27	30.00	1000	11.59
Mid	5788.240269	-2.55	1.11805	20.26	18.83	76.35	30.00	1000	11.17
High	5848.889420	-2.47	1.10270	20.28	18.91	77.85	30.00	1000	11.09

Sample Calculation:

Result = Reading + Cable Loss (supplied by customer)+ Attenuator

* In the above table, factor 0.0dB represents no use of Atten. and/or Filter.

Radiated Spurious Emission

* The result is rounded off to the second decimal place. Therefore, there may be 0.1 difference for the result.

DATA OF RADIATED EMISSION TEST

UL Apex Co., Ltd. Head Office EMC Lab. No.4 Semi Anechoic Chamber
Date : 2006/08/05 02:21:49

Company : BROTHER INDUSTRIES, LTD. Report No. : 26KE0022-HO
Kind of EUT : Facsimile machine Power : AC120V / 60Hz
Model No. : MFC-945CW Temp./Humi. : 25deg. C / 63%
Serial No. : 0001 Operator : Takumi Shimada

Mode / Remarks : Tx ch1 (5725.809328MHz) / Hor:ANT Angle 0deg., Ver:ANT Angle 90deg. (MAX)

LIMIT : FCC15C § 15.247(d) 3m, below1GHz:QP, above1GHz:PK / RSS-Gen / RSS-210
FCC15C § 15.247(d) 3m, below1GHz:QP, above1GHz:AV / RSS-Gen / RSS-210

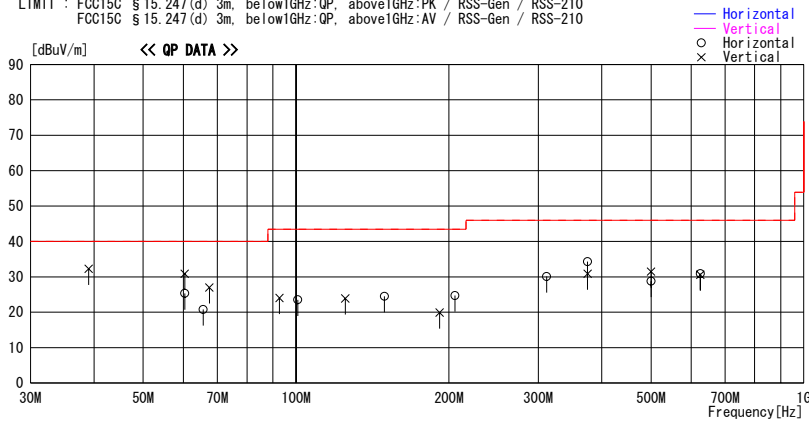

Frequency [MHz]	Reading [dBuV]	DET	Antenna		Level [dBuV/m]	Angle [Deg]	Height [cm]	Polar.	Limit [dBuV/m]	Margin [dB]	Comment
			Factor [dB/m]	Loss& Gain [dB]							
39.037	42.1	QP	14.9	-24.7	32.3	170	100	Vert.	40.0	7.7	
60.373	46.6	QP	8.7	-24.4	30.9	121	100	Vert.	40.0	9.1	
60.377	41.0	QP	8.7	-24.4	25.3	200	160	Hori.	40.0	14.7	
65.602	37.1	QP	8.0	-24.3	20.8	200	160	Hori.	40.0	19.2	
67.492	43.5	QP	7.7	-24.2	27.0	124	100	Vert.	40.0	13.0	
92.734	38.1	QP	9.7	-23.8	24.0	233	100	Vert.	43.5	19.5	
100.810	36.1	QP	11.1	-23.7	23.5	119	183	Hori.	43.5	20.0	
125.029	33.4	QP	13.9	-23.4	23.9	64	100	Vert.	43.5	19.6	
149.200	32.2	QP	15.4	-23.1	24.5	125	112	Hori.	43.5	19.0	
205.638	30.2	QP	17.1	-22.6	24.7	153	165	Hori.	43.5	18.8	
191.730	25.7	QP	16.9	-22.7	19.9	359	100	Vert.	43.5	23.6	
311.479	35.1	QP	16.9	-21.9	30.1	256	100	Hori.	46.0	15.9	
375.021	34.6	QP	17.7	-21.4	30.9	118	111	Vert.	46.0	15.1	
375.023	38.0	QP	17.7	-21.4	34.3	56	100	Hori.	46.0	11.7	
500.020	29.6	QP	19.9	-20.7	28.8	0	100	Hori.	46.0	17.2	
500.021	32.3	QP	19.9	-20.7	31.5	114	100	Vert.	46.0	14.5	
625.037	30.0	QP	20.8	-20.2	30.6	35	143	Vert.	46.0	15.4	
625.032	30.3	QP	20.8	-20.2	30.9	149	115	Hori.	46.0	15.1	

CHART: WITH FACTOR ANT TYPE : -30MHz: LOOP, 30-300MHz: BICONICAL, 300MHz-1000MHz: LOGPERIODIC, 1000MHz-: HORN
CALCULATION: RESULT = READING + ANT FACTOR + LOSS (CABLE+ATTEN.) - GAIN (AMP)

DATA OF RADIATED EMISSION TEST

UL Apex Co., Ltd. Head Office EMC Lab. No. 4 Semi Anechoic Chamber
Date : 2006/08/05 02:35:03

Company : BROTHER INDUSTRIES, LTD. Report No. : 26KE0022-HO
Kind of EUT : Facsimile machine Power : AC120V / 60Hz
Model No. : MFC-845CW Temp./Humi. : 25deg.C / 63%
Serial No. : 0001 Operator : Takumi Shimada

Mode / Remarks : Tx ch71 (5788.240269MHz) / Hor:ANT Angle 0deg., Ver:ANT Angle 90deg. (MAX)

LIMIT : FCC15C §15.247(d) 3m, below1GHz:QP, above1GHz:PK / RSS-Gen / RSS-210
FCC15C §15.247(d) 3m, below1GHz:QP, above1GHz:AV / RSS-Gen / RSS-210

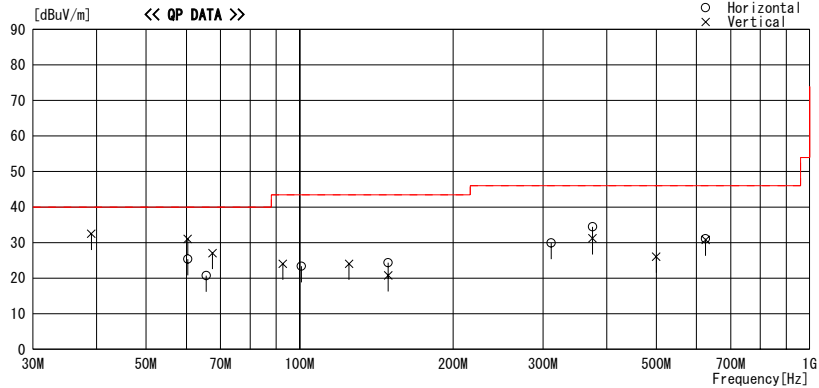

Frequency [MHz]	Reading [dBuV]	DET	Antenna		Level [dBuV/m]	Angle [Deg]	Height [cm]	Polar.	Limit [dBuV/m]	Margin [dB]	Comment
			Factor [dB/m]	Loss & Gain [dB]							
39.057	42.3	QP	14.9	-24.7	32.5	170	100	Vert.	40.0	7.5	
60.363	46.8	QP	8.7	-24.4	31.1	121	100	Vert.	40.0	8.9	
60.389	41.1	QP	8.7	-24.4	25.4	200	160	Hori.	40.0	14.6	
65.593	37.0	QP	8.0	-24.3	20.7	200	160	Hori.	40.0	19.3	
67.489	43.6	QP	7.7	-24.2	27.1	124	100	Vert.	40.0	12.9	
92.740	38.2	QP	9.7	-23.8	24.1	233	100	Vert.	43.5	19.4	
100.807	36.0	QP	11.1	-23.7	23.4	119	183	Hori.	43.5	20.1	
125.008	33.6	QP	13.9	-23.4	24.1	64	100	Vert.	43.5	19.4	
149.180	32.1	QP	15.4	-23.1	24.4	125	112	Hori.	43.5	19.1	
149.190	28.5	QP	15.4	-23.1	20.8	235	122	Vert.	43.5	22.7	
311.472	34.9	QP	16.9	-21.9	29.9	256	100	Hori.	46.0	16.1	
375.015	38.2	QP	17.7	-21.4	34.5	56	100	Hori.	46.0	11.5	
375.017	34.9	QP	17.7	-21.4	31.2	118	111	Vert.	46.0	14.8	
500.019	26.9	QP	19.9	-20.7	26.1	109	100	Vert.	46.0	19.9	
625.022	30.2	QP	20.8	-20.2	30.8	35	143	Vert.	46.0	15.2	
625.023	30.5	QP	20.8	-20.2	31.1	149	115	Hori.	46.0	14.9	

CHART WITH FACTOR ANT TYPE : -30MHz: LOOP, 30-300MHz: BICONICAL, 300MHz-1000MHz: LOGPERIODIC, 1000MHz-: HORN
CALCULATION RESULT = READING + ANT FACTOR + LOSS (CABLE+ATTEN.) - GAIN (AMP)

DATA OF RADIATED EMISSION TEST

UL Apex Co., Ltd. Head Office EMC Lab. No. 4 Semi Anechoic Chamber
Date : 2006/08/05 02:46:02

Company : BROTHER INDUSTRIES, LTD. Report No. : 26KE0022-HO
Kind of EUT : Facsimile machine Power : AC120V / 60Hz
Model No. : MFC-845CW Temp./Humi. : 25deg.C / 63%
Serial No. : 0001 Operator : Takumi Shimada

Mode / Remarks : Tx ch139(5848.889420MHz) / Hor:ANT Angle 0deg. Ver:ANT Angle 90deg. (MAX)

LIMIT : FCC15C §15.247(d) 3m, below1GHz:QP, above1GHz:PK / RSS-Gen / RSS-210
FCC15C §15.247(d) 3m, below1GHz:QP, above1GHz:AV / RSS-Gen / RSS-210

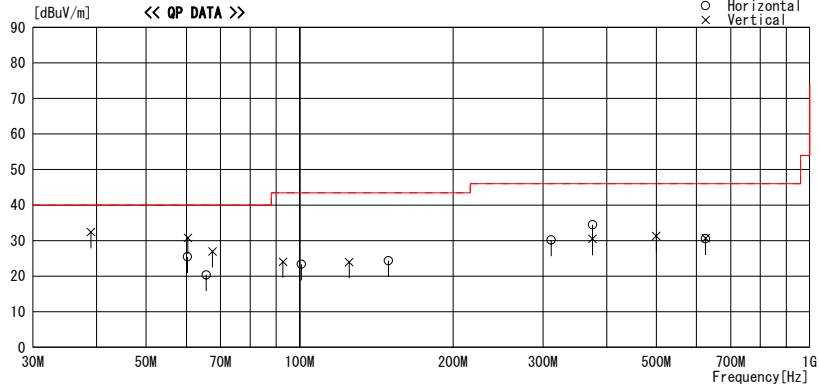

Frequency [MHz]	Reading [dBuV]	DET	Antenna	Loss &	Level [dBuV/m]	Angle [Deg]	Height [cm]	Polar.	Limit [dBuV/m]	Margin [dB]	Comment
			Factor [dB/m]	Gain [dB]							
38.987	42.2	QP	14.9	-24.7	32.4	170	100	Vert.	40.0	7.6	
60.325	41.1	QP	8.8	-24.4	25.5	200	160	Hori.	40.0	14.5	
60.379	46.5	QP	8.7	-24.4	30.8	121	100	Vert.	40.0	9.2	
65.579	36.7	QP	8.0	-24.3	20.4	200	160	Hori.	40.0	19.6	
67.487	43.5	QP	7.7	-24.2	27.0	124	100	Vert.	40.0	13.0	
92.756	38.2	QP	9.7	-23.8	24.1	233	100	Vert.	43.5	19.4	
100.798	36.0	QP	11.1	-23.7	23.4	183	119	Hori.	43.5	20.1	
125.049	33.5	QP	13.9	-23.4	24.0	64	100	Vert.	43.5	19.5	
149.213	32.1	QP	15.4	-23.1	24.4	125	112	Hori.	43.5	19.1	
311.476	35.2	QP	16.9	-21.9	30.2	256	100	Hori.	46.0	15.8	
375.034	34.2	QP	17.7	-21.4	30.5	118	111	Vert.	46.0	15.5	
375.044	38.2	QP	17.7	-21.4	34.5	56	100	Hori.	46.0	11.5	
500.001	32.1	QP	19.9	-20.7	31.3	114	100	Vert.	46.0	14.7	
625.026	30.1	QP	20.8	-20.2	30.7	35	143	Vert.	46.0	15.3	
625.034	30.0	QP	20.8	-20.2	30.6	149	115	Hori.	46.0	15.4	

CHART WITH FACTOR ANT TYPE : -30MHz: LOOP, 30-300MHz: BICONICAL, 300MHz-1000MHz: LOGPERIODIC, 1000MHz-: HORN
CALCULATION RESULT = READING + ANT FACTOR + LOSS (CABLE+ATTEN.) - GAIN (AMP)

Radiated Spurious Emission
DATA OF SPURIOUS EMISSIONS(1GHz to 40GHz)

UL Apex Co., Ltd.
Head Office EMC Lab. No.4 Semi Anechoic Chambe

Company	: BROTHER INDUSTRIES, LTD.	REPORT NO	: 26KE0022-HO
Equipment	: Facsimile machine	REGULATION	: Fcc Part15 Subpart C 15.247(d)
Model	: MFC-845CW	TEST DISTANCE	: 3/1/0.5m
Serial No.	: 0001	DATE	: August 3, 2006
Power	: AC 120 V / 60 Hz	TEMPERATURE	: 25deg.C
Mode	: Tx 5725.809328MHz (ch1)	HUMIDITY	: 63%
Remarks	: Horizontal:ANT Angle 0deg.	ENGINEER	: Takumi Shimada
	: Vertical:ANT Angle 90deg.		

PK DETECT (RBW: 1MHz, VBW: 1MHz)

No.	FREQ [MHz]	S/A READING		ANT Factor [dB/m]	AMP GAIN [dB]	CABLE LOSS [dB]	Hi-Pass Filter [dB]	RESULT		Limit PK [dBuV/m]	MARGIN	
		HOR	VER					HOR	VER		HOR	VER
Test distance 3meters RESULT=Reading + ANT Factor - Amp Gain + Cable Loss + Filter Loss												
1	2399.9	53.9	55.5	30.6	32.7	2.1	0.0	53.9	55.5	74.0	20.1	18.5
2	3325.8	46.6	47.5	31.5	32.1	2.6	0.0	48.6	49.5	74.0	25.4	24.5
3	4800.3	53.9	55.6	35.7	31.5	3.2	0.0	61.3	63.0	74.0	12.7	11.0
4	5712.3	51.3	49.7	36.5	30.5	3.4	0.0	60.7	59.1	74.0	13.3	14.9
6	5739.6	51.6	51.8	36.5	30.5	3.4	0.0	61.0	61.2	74.0	13.0	12.8
7	6651.5	45.6	46.8	36.9	31.6	3.7	0.0	54.6	55.8	74.0	19.4	18.2
8	7577.5	44.1	45.2	38.1	32.6	4.0	1.1	54.7	55.8	74.0	19.3	18.2
Test distance 1meters RESULT=Reading + ANT Factor - Amp Gain + Cable Loss + Filter Loss - Dfac												
9	10526.4	43.5	49.0	36.4	33.0	5.2	0.6	43.2	48.7	74.0	30.8	25.3
10	11451.3	52.3	56.0	38.3	32.7	5.5	0.8	54.7	58.4	74.0	19.3	15.6
12	22902.7	56.8	64.4	39.8	32.2	7.7	0.5	63.1	70.7	74.0	10.9	3.3
13	28627.8	46.1	49.6	45.2	24.3	12.3	0.0	63.7	67.2	74.0	10.3	6.8
14	34354.9	39.5	38.8	45.2	24.7	13.1	0.0	57.5	56.8	74.0	16.5	17.2

AV DETECT (RBW: 1MHz, VBW: 10Hz)

No.	FREQ [MHz]	S/A READING		ANT Factor [dB/m]	AMP GAIN [dB]	CABLE LOSS [dB]	Hi-Pass Filter [dB]	RESULT		Limit AV [dBuV/m]	MARGIN	
		HOR	VER					HOR	VER		HOR	VER
Test distance 3meters RESULT=Reading + ANT Factor - Amp Gain + Cable Loss + Filter Loss												
1	2399.9	36.5	37.0	30.6	32.7	2.1	0.0	36.5	37.0	54.0	17.5	17.0
2	3325.8	39.4	42.0	31.5	32.1	2.6	0.0	41.4	44.0	54.0	12.6	10.0
3	4800.3	32.5	35.0	35.7	31.5	3.2	0.0	39.9	42.4	54.0	14.1	11.6
4	5712.3	30.8	31.0	36.5	30.5	3.4	0.0	40.2	40.4	54.0	13.8	13.6
6	5739.6	30.9	31.3	36.5	30.5	3.4	0.0	40.3	40.7	54.0	13.7	13.3
7	6651.5	31.6	31.8	36.9	31.6	3.7	0.0	40.6	40.8	54.0	13.4	13.2
8	7577.5	31.9	32.4	38.1	32.6	4.0	1.1	42.5	43.0	54.0	11.5	11.0
Test distance 1meters RESULT=Reading + ANT Factor - Amp Gain + Cable Loss + Filter Loss - Dfac												
9	10526.4	31.3	32.5	36.4	33.0	5.2	0.6	31.0	32.2	54.0	23.0	21.8
10	11451.3	33.9	33.4	38.3	32.7	5.5	0.8	36.3	35.8	54.0	17.7	18.2
12	22902.7	35.4	36.7	39.8	32.2	7.7	0.5	41.7	43.0	54.0	12.3	11.0
13	28627.8	24.9	24.9	45.2	24.3	12.3	0.0	42.5	42.5	54.0	11.5	11.5
14	34354.9	27.1	27.2	45.2	24.7	13.1	0.0	45.1	45.2	54.0	8.9	8.8

20dBc(Fundamental 5725.809328MI)(RBW: 100kHz, VBW: 300kHz)

No.	FREQ [MHz]	S/A READING		ANT Factor [dB/m]	AMP GAIN [dB]	CABLE LOSS [dB]	Hi-Pass Filter [dB]	RESULT		Limit 20dBc [dBuV/m]	MARGIN	
		HOR	VER					HOR	VER		HOR	VER
Test distance 3meters RESULT=Reading + ANT Factor - Amp Gain + Cable Loss + Filter Loss												
0	5725.8	107.9	110.7	36.5	30.5	3.4	0.0	117.3	120.1	-	-	-
5	5725.0	75.0	76.1	36.5	30.5	3.4	0.0	84.4	85.5	Funda-20dB	12.9	14.6
11	17178.0	73.9	73.5	46.1	31.9	6.6	0.4	85.6	85.2	Funda-20dB	11.7	14.9

Test Distance 1.0m : Distance Factor(Dfac) = 20log(3/1.0) = 9.5dB

*Except for the above table : All other spurious emissions were less than 20dB for the limit.

*In the frequency over the fifth harmonic, the noise from the EUT was not seen. The data above is its base noise.

*The result is rounded off to the second decimal place. Therefore, there may be 0.1 difference for the result.

*Hi-Pass Fiter was not used for factor 0.0dB of the above table.

Radiated Spurious Emission

UL Apex Co., Ltd.

Head Office EMC Lab. No.4 Semi Anechoic Chamber

Company : BROTHER INDUSTRIES, LTD.
Equipment : Facsimile machine
Model : MFC-845CW
Serial No. : 0001
Power : AC 120 V / 60 Hz
Mode : Tx 5788.240269MHz (ch71)
Remarks : Horizontal:ANT Angle 0deg.
: Vertical:ANT Angle 90deg.

REPORT NO : 26KE0022-HO
REGULATION : Fee Part15 Subpart C 15.247(d)
TEST DISTANCE : 3/1.0.5m
DATE : August 3, 2006
TEMPERATURE : 25deg.C
HUMIDITY : 63%
ENGINEER : Takumi Shimada

PK DETECT (RBW: 1MHz, VBW: 1MHz)

No.	FREQ [MHz]	S/A READING		ANT Factor [dB/m]	AMP GAIN [dB]	CABLE LOSS [dB]	Hi-Pass Filter [dB]	RESULT		Limit PK [dBuV/m]	MARGIN	
		HOR	VER					HOR	VER		HOR	VER
Test distance 3meters RESULT=Reading + ANT Factor - Amp Gain + Cable Loss + Filter Loss												
1	2428.5	50.6	55.0	30.5	32.6	2.1	0.0	50.6	55.0	74.0	23.4	19.0
2	3359.7	45.5	42.7	31.5	32.1	2.6	0.0	47.5	44.7	74.0	26.5	29.3
3	4857.5	50.9	55.4	36.0	31.5	3.2	0.0	58.6	63.1	74.0	15.4	10.9
4	5774.3	52.2	50.7	36.6	30.4	3.4	0.0	61.8	60.3	74.0	12.2	13.7
5	5802.0	51.1	53.0	36.6	30.4	3.4	0.0	60.7	62.6	74.0	13.3	11.4
6	6143.3	48.0	48.9	36.8	30.5	3.6	0.0	57.9	58.8	74.0	16.1	15.2
7	6719.3	47.1	48.0	36.9	31.7	3.7	0.0	56.0	56.9	74.0	18.0	17.1
8	7650.4	46.5	45.8	37.9	32.6	4.0	1.0	56.8	56.1	74.0	17.2	17.9
Test distance 1meters RESULT=Reading + ANT Factor - Amp Gain + Cable Loss + Filter Loss - Dfac												
9	11576.9	55.5	57.7	38.7	32.7	5.6	0.7	58.3	60.5	74.0	15.7	13.5
12	28941.9	42.7	45.9	45.3	24.3	12.3	0.0	60.4	63.6	74.0	13.6	10.4
13	34729.4	41.0	41.2	45.1	24.5	13.4	0.0	59.4	59.6	74.0	14.6	14.4

AV DETECT (RBW: 1MHz, VBW: 10Hz)

No.	FREQ [MHz]	S/A READING		ANT Factor [dB/m]	AMP GAIN [dB]	CABLE LOSS [dB]	Hi-Pass Filter [dB]	RESULT		Limit AV [dBuV/m]	MARGIN	
		HOR	VER					HOR	VER		HOR	VER
Test distance 3meters RESULT=Reading + ANT Factor - Amp Gain + Cable Loss + Filter Loss												
1	2428.5	34.5	35.9	30.5	32.6	2.1	0.0	34.5	35.9	54.0	19.5	18.1
2	3359.7	36.7	42.7	31.5	32.1	2.6	0.0	38.7	44.7	54.0	15.3	9.3
3	4857.5	31.5	34.6	36.0	31.5	3.2	0.0	39.2	42.3	54.0	14.8	11.7
4	5774.3	29.9	30.0	36.6	30.4	3.4	0.0	39.5	39.6	54.0	14.5	14.4
5	5802.0	30.1	30.3	36.6	30.4	3.4	0.0	39.7	39.9	54.0	14.3	14.1
6	6143.3	30.0	29.8	36.8	30.5	3.6	0.0	39.9	39.7	54.0	14.1	14.3
7	6719.3	31.1	31.5	36.9	31.7	3.7	0.0	40.0	40.4	54.0	14.0	13.6
8	7650.4	31.3	31.4	37.9	32.6	4.0	1.0	41.6	41.7	54.0	12.4	12.3
Test distance 1meters RESULT=Reading + ANT Factor - Amp Gain + Cable Loss + Filter Loss - Dfac												
9	11576.9	33.5	34.4	38.7	32.7	5.6	0.7	36.3	37.2	54.0	17.7	16.8
12	28941.9	23.9	24.4	45.3	24.3	12.3	0.0	41.6	42.1	54.0	12.4	11.9
13	34729.4	28.1	28.1	45.1	24.5	13.4	0.0	46.5	46.5	54.0	7.5	7.5

20dBc(Fundamental 5725.809328MHz) (RBW: 100kHz, VBW: 300kHz)

No.	FREQ [MHz]	S/A READING		ANT Factor [dB/m]	AMP GAIN [dB]	CABLE LOSS [dB]	Hi-Pass Filter [dB]	RESULT		Limit 20dBc [dBuV/m]	MARGIN	
		HOR	VER					HOR	VER		HOR	VER
Test distance 3meters RESULT=Reading + ANT Factor - Amp Gain + Cable Loss + Filter Loss												
0	5788.2	110.8	110.8	36.6	31.9	3.8	0.0	119.3	119.3	-	-	-
10	17365.3	64.2	65.5	46.2	31.9	6.9	0.6	76.5	77.8	Funda-20dB	22.8	21.5
11	23153.4	52.1	61.6	39.7	32.2	7.8	0.6	58.5	68.0	Funda-20dB	40.8	31.3

Test Distance 1.0m : Distance Factor(Dfac) = 20log(3/1.0) = 9.5dB

*Except for the above table : All other spurious emissions were less than 20dB for the limit.

*In the frequency over the fifth harmonic, the noise from the EUT was not seen. The data above is its base noise.

*The result is rounded off to the second decimal place. Therefore, there may be 0.1 difference for the result.

*Hi-Pass Filter was not used for factor 0.0dB of the above table.

UL Apex Co., Ltd.

Head Office EMC Lab.

4383-326 Asama-cho, Ise-shi, Mie-ken 516-0021 JAPAN

Telephone : +81 596 24 8116

Facsimile : +81 596 24 8124

MF060b(14.06.06)

Radiated Spurious Emission

UL Apex Co., Ltd.
Head Office EMC Lab. No.4 Semi Anechoic Chambe

Company	: BROTHER INDUSTRIES, LTD.	REPORT NO	: 26KE0022-HO
Equipment	: Facsimile machine	REGULATION	: Fcc Part15 Subpart C 15.247(d)
Model	: MFC-845CW	TEST DISTANCE	: 3/1/0.5m
Serial No.	: 0001	DATE	: August 3, 2006
Power	: AC 120 V / 60 Hz	TEMPERATURE	: 25deg.C
Mode	: Tx 5848.889420MHz (ch139)	HUMIDITY	: 63%
Remarks	: Horizontal:ANT Angle 0deg.	ENGINEER	: Takumi Shimada
	: Vertical:ANT Angle 90deg.		

PK DETECT (RBW: 1MHz, VBW: 1MHz)

No.	FREQ [MHz]	S/A READING		ANT Factor [dB/m]	AMP GAIN [dB]	CABLE LOSS [dB]	Hi-Pass Filter [dB]	RESULT		Limit PK [dBuV/m]	MARGIN	
		HOR	VER					HOR	VER		HOR	VER
Test distance 3meters RESULT=Reading + ANT Factor - Amp Gain + Cable Loss + Filter Loss												
1	2489.1	56.9	53.1	30.4	32.6	2.2	0.0	56.9	53.1	74.0	17.1	20.9
2	3359.5	45.8	50.8	31.5	32.1	2.6	0.0	47.8	52.8	74.0	26.2	21.2
3	4978.1	54.4	58.1	36.8	31.5	3.2	0.0	62.9	66.6	74.0	11.1	7.4
5	5862.9	50.1	48.0	36.6	30.3	3.5	0.0	59.9	57.8	74.0	14.1	16.2
6	5971.0	56.4	52.0	36.7	30.2	3.5	0.0	66.4	62.0	74.0	7.6	12.0
7	6719.3	44.6	51.5	36.9	31.7	3.7	0.0	53.5	60.4	74.0	20.5	13.6
8	7589.9	46.0	46.4	38.1	32.6	4.0	1.1	56.6	57.0	74.0	17.4	17.0
Test distance 1meters RESULT=Reading + ANT Factor - Amp Gain + Cable Loss + Filter Loss - Dfac												
9	11697.9	55.3	62.3	39.1	32.7	5.6	0.7	58.5	65.5	74.0	15.5	8.5
12	29245.1	41.6	45.3	45.4	24.4	12.4	0.0	59.4	63.1	74.0	14.6	10.9
13	35093.3	41.2	42.0	45.0	24.2	13.7	0.0	60.1	60.9	74.0	13.9	13.1

AV DETECT (RBW: 1MHz, VBW: 10Hz)

No.	FREQ [MHz]	S/A READING		ANT Factor [dB/m]	AMP GAIN [dB]	CABLE LOSS [dB]	Hi-Pass Filter [dB]	RESULT		Limit AV [dBuV/m]	MARGIN	
		HOR	VER					HOR	VER		HOR	VER
Test distance 3meters RESULT=Reading + ANT Factor - Amp Gain + Cable Loss + Filter Loss												
1	2489.1	38.2	38.3	30.4	32.6	2.2	0.0	38.2	38.3	54.0	15.8	15.7
2	3359.5	38.6	42.2	31.5	32.1	2.6	0.0	40.6	44.2	54.0	13.4	9.8
3	4978.1	32.7	37.9	36.8	31.5	3.2	0.0	41.2	46.4	54.0	12.8	7.6
5	5862.9	31.1	30.9	36.6	30.3	3.5	0.0	40.9	40.7	54.0	13.1	13.3
6	5971.0	32.6	31.8	36.7	30.2	3.5	0.0	42.6	41.8	54.0	11.4	12.2
7	6719.3	32.3	33.4	36.9	31.7	3.7	0.0	41.2	42.3	54.0	12.8	11.7
8	7589.9	32.4	32.6	38.1	32.6	4.0	1.1	43.0	43.2	54.0	11.0	10.8
Test distance 1meters RESULT=Reading + ANT Factor - Amp Gain + Cable Loss + Filter Loss - Dfac												
9	11697.9	33.3	33.3	39.1	32.7	5.6	0.7	36.5	36.5	54.0	17.5	17.5
12	29245.1	23.1	23.9	45.4	24.4	12.4	0.0	40.9	41.7	54.0	13.1	12.3
13	35093.3	29.1	29.3	45.0	24.2	13.7	0.0	48.0	48.2	54.0	6.0	5.8

20dBc(Fundamental 5848.889420MI) (RBW: 100kHz, VBW: 300kHz)

No.	FREQ [MHz]	S/A READING		ANT Factor [dB/m]	AMP GAIN [dB]	CABLE LOSS [dB]	Hi-Pass Filter [dB]	RESULT		Limit 20dBc [dBuV/m]	MARGIN	
		HOR	VER					HOR	VER		HOR	VER
Test distance 3meters RESULT=Reading + ANT Factor - Amp Gain + Cable Loss + Filter Loss												
0	5849.0	106.4	108.6	36.6	30.3	3.5	0.0	116.2	118.4	-	-	-
4	5850.0	61.1	62.3	36.6	30.3	3.5	0.0	70.9	72.1	Funda-20dB	25.3	26.3
10	17546.0	62.7	66.9	46.2	31.8	6.9	0.5	75.0	79.2	Funda-20dB	21.2	19.2
11	23395.1	55.1	63.4	39.3	32.1	7.8	0.6	70.7	79.0	Funda-20dB	25.5	19.4

Test Distance 1.0m : Distance Factor(Dfac) = 20log(3/1.0) = 9.5dB

*Except for the above table : All other spurious emissions were less than 20dB for the limit.

*In the frequency over the fifth harmonic, the noise from the EUT was not seen. The data above is its base noise.

*The result is rounded off to the second decimal place. Therefore, there may be 0.1 difference for the result.

*Hi-Pass Fiter was not used for factor 0.0dB of the above table.

Conducted Spurious Emission
Ch:Low

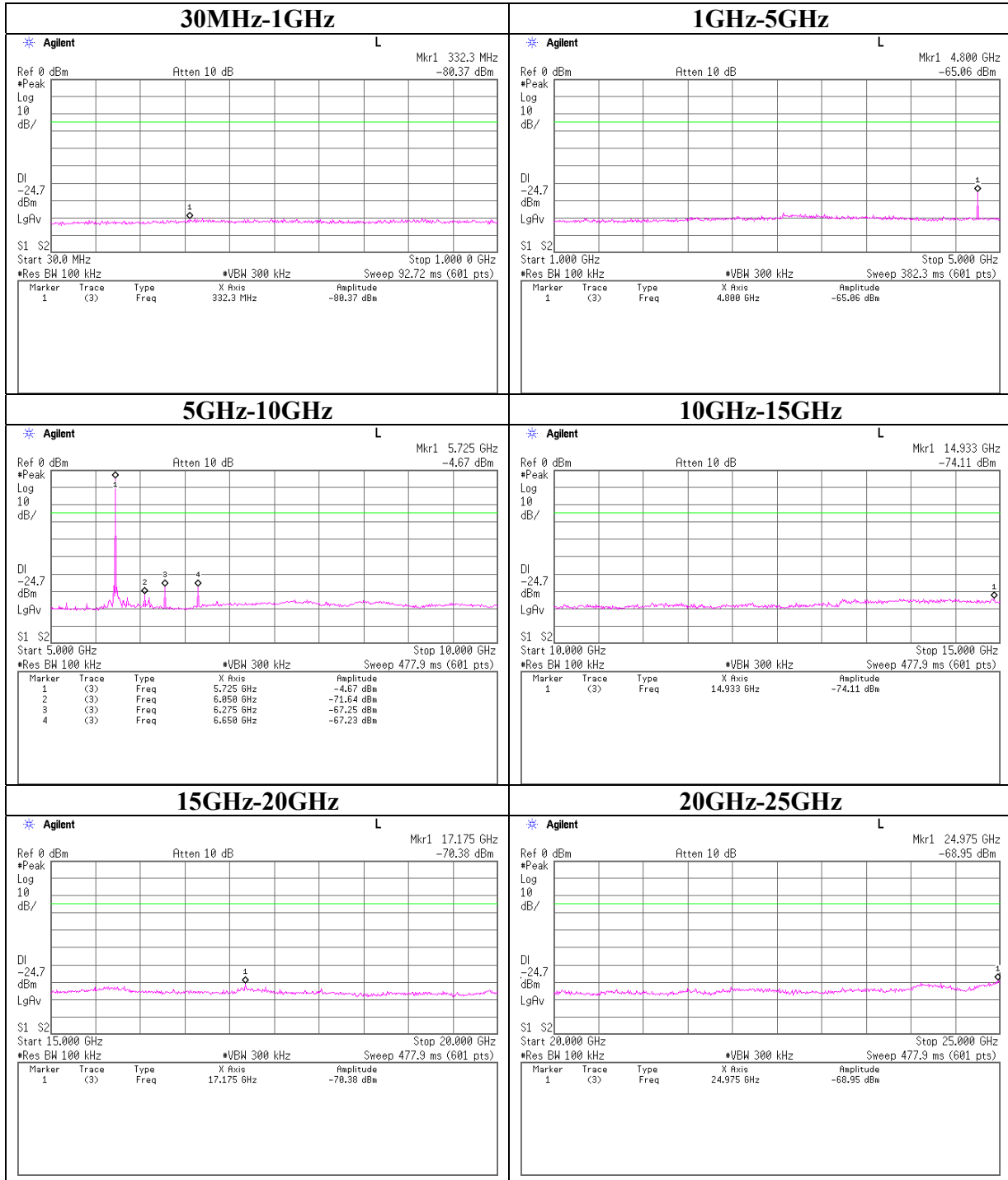

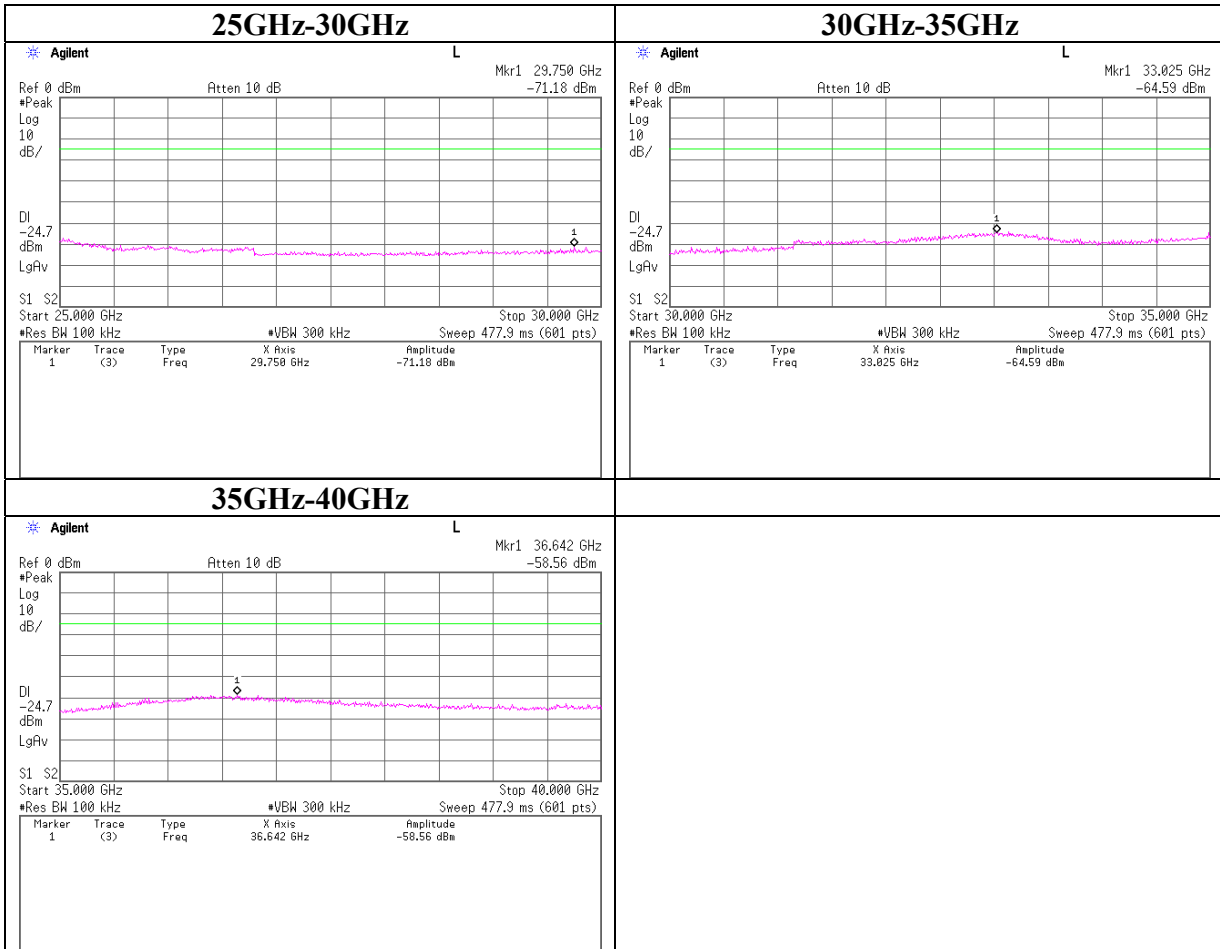

Conducted Spurious Emission
Ch:Mid

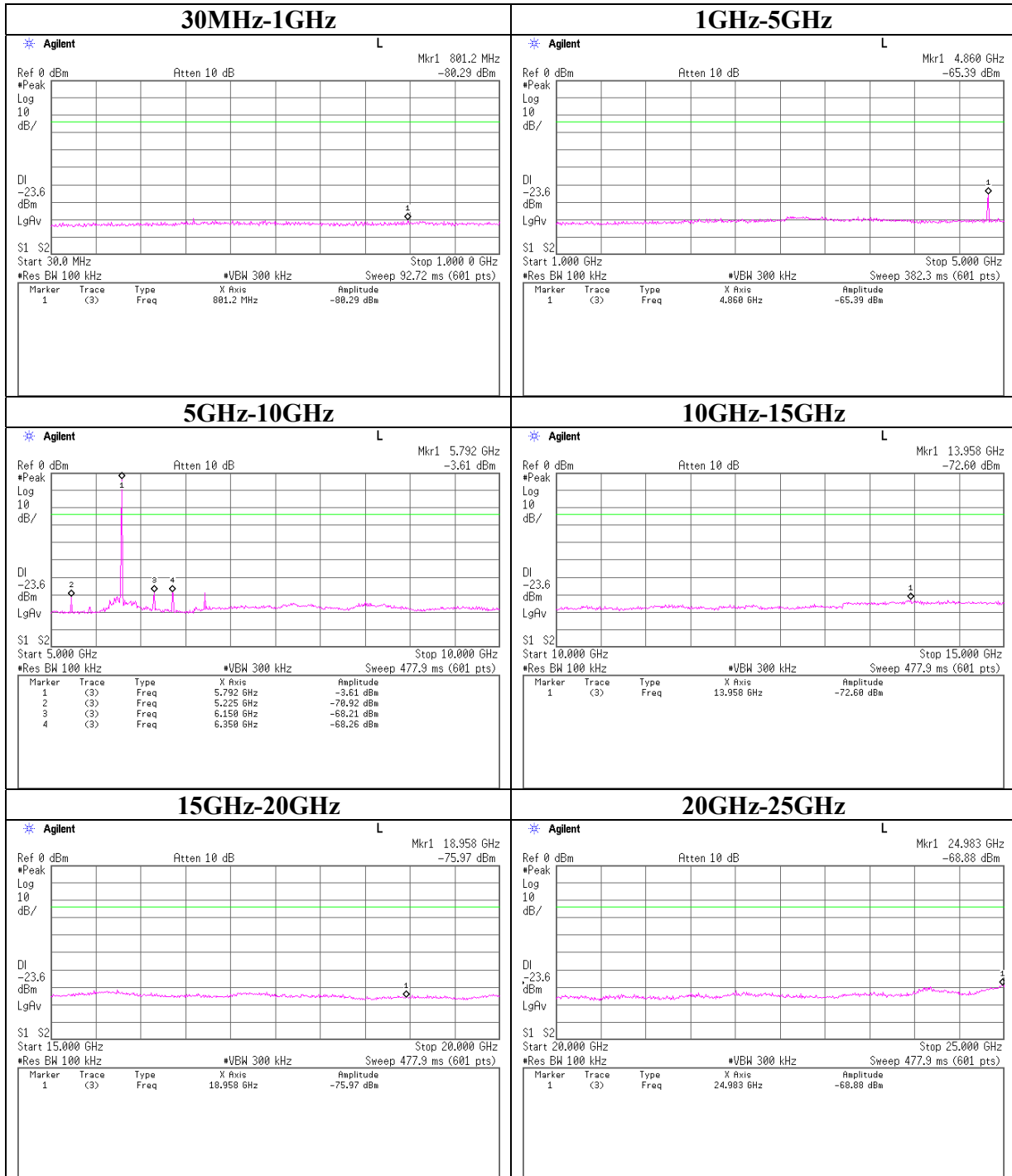

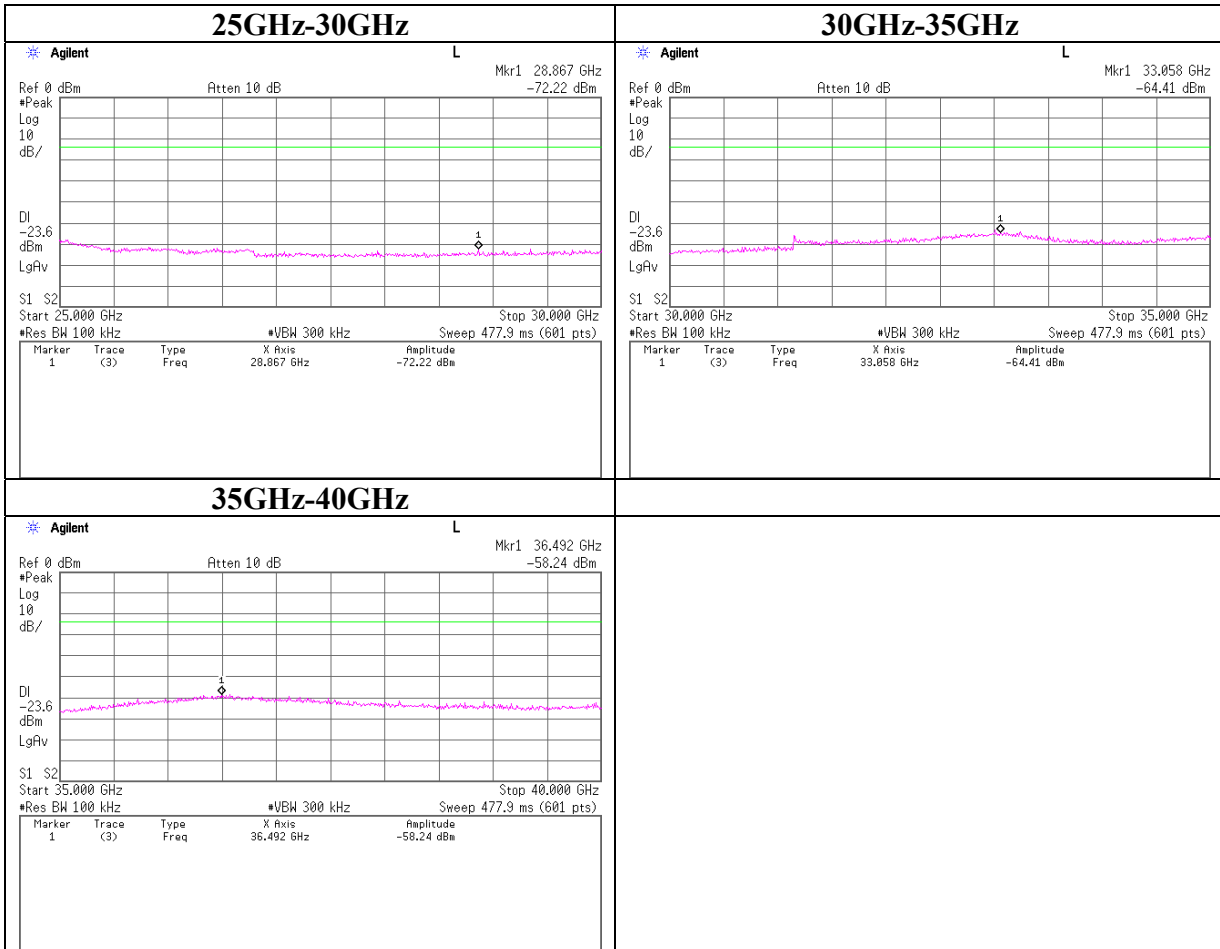

Conducted Spurious Emission
Ch:High

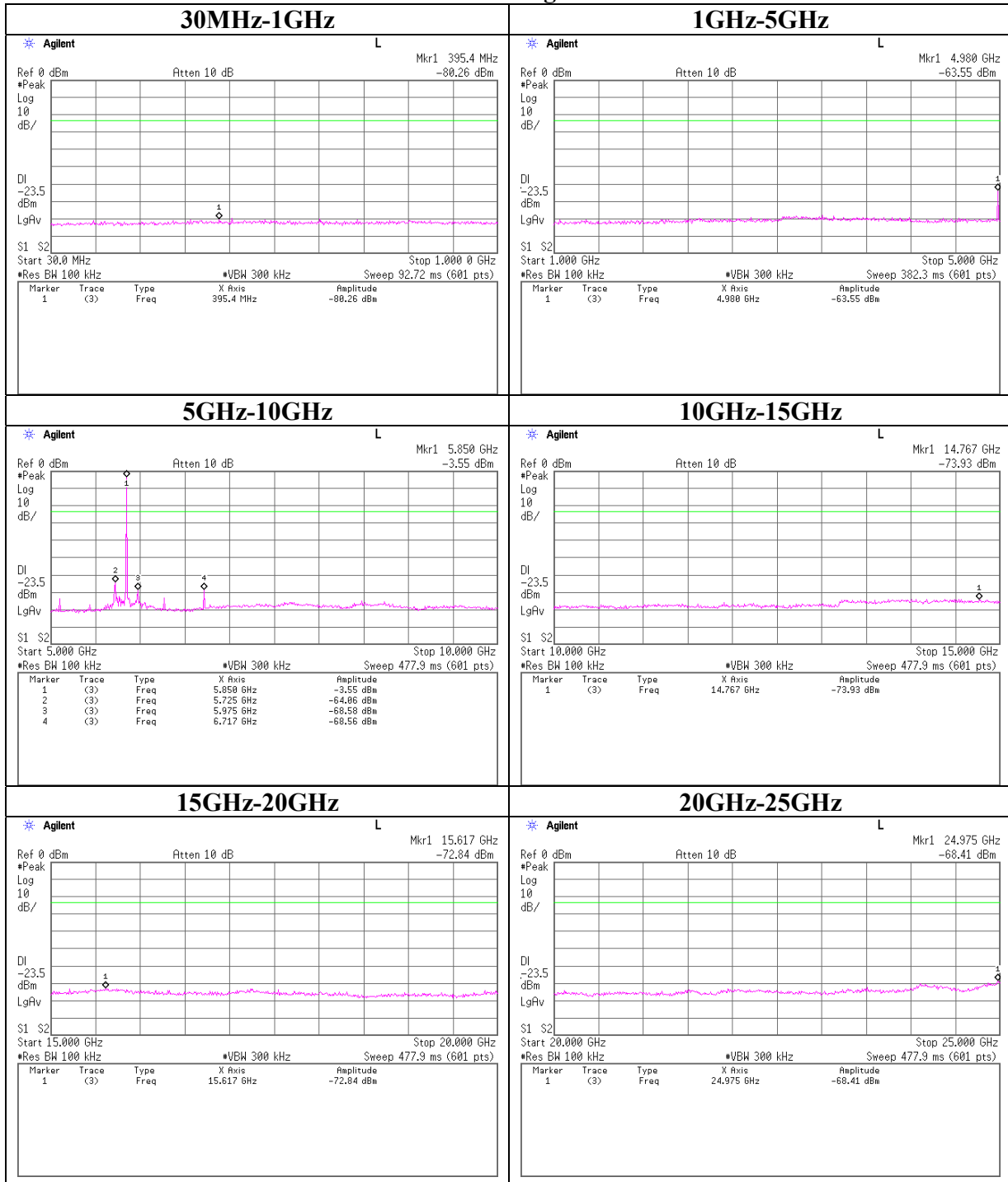

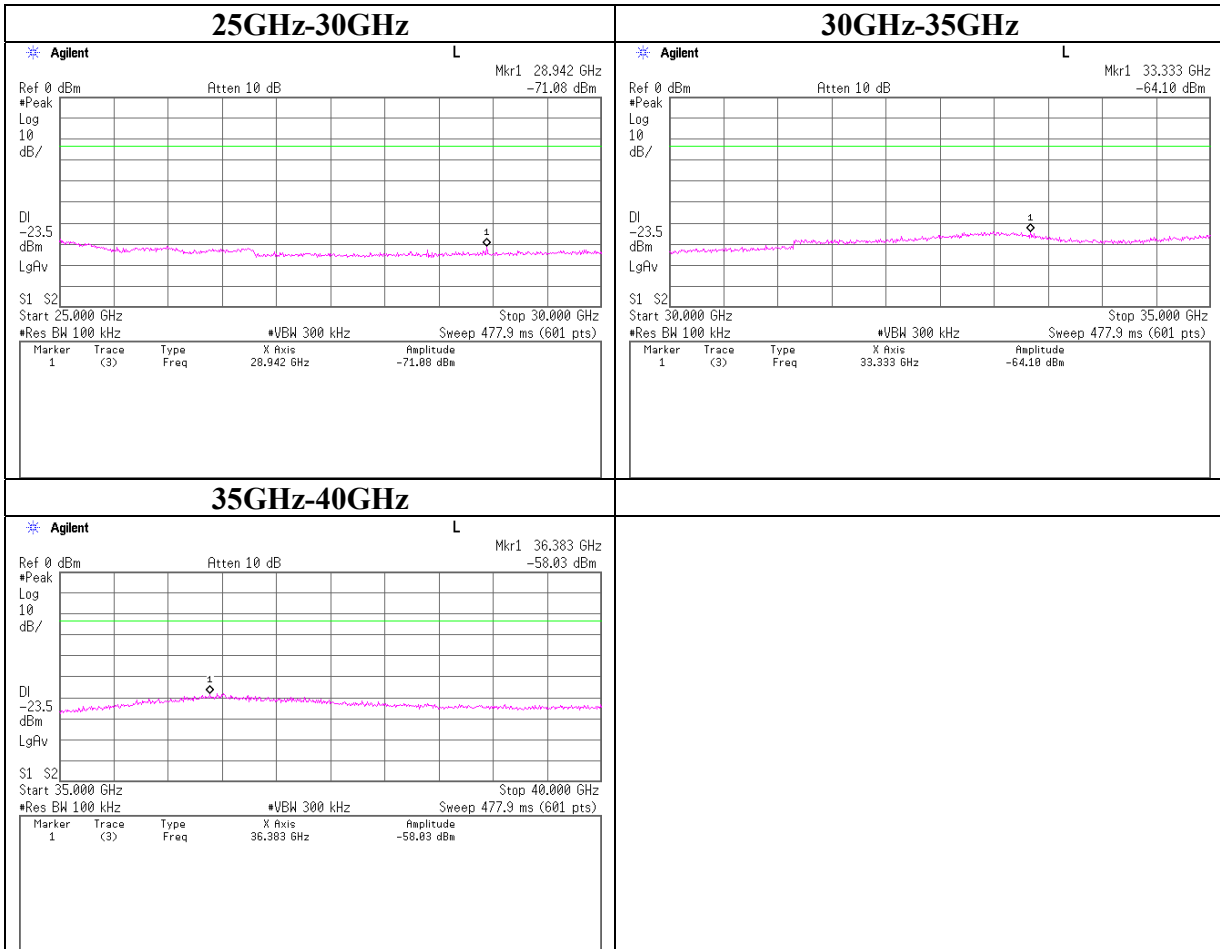

Conducted Spurious Emission
Band Edge compliance

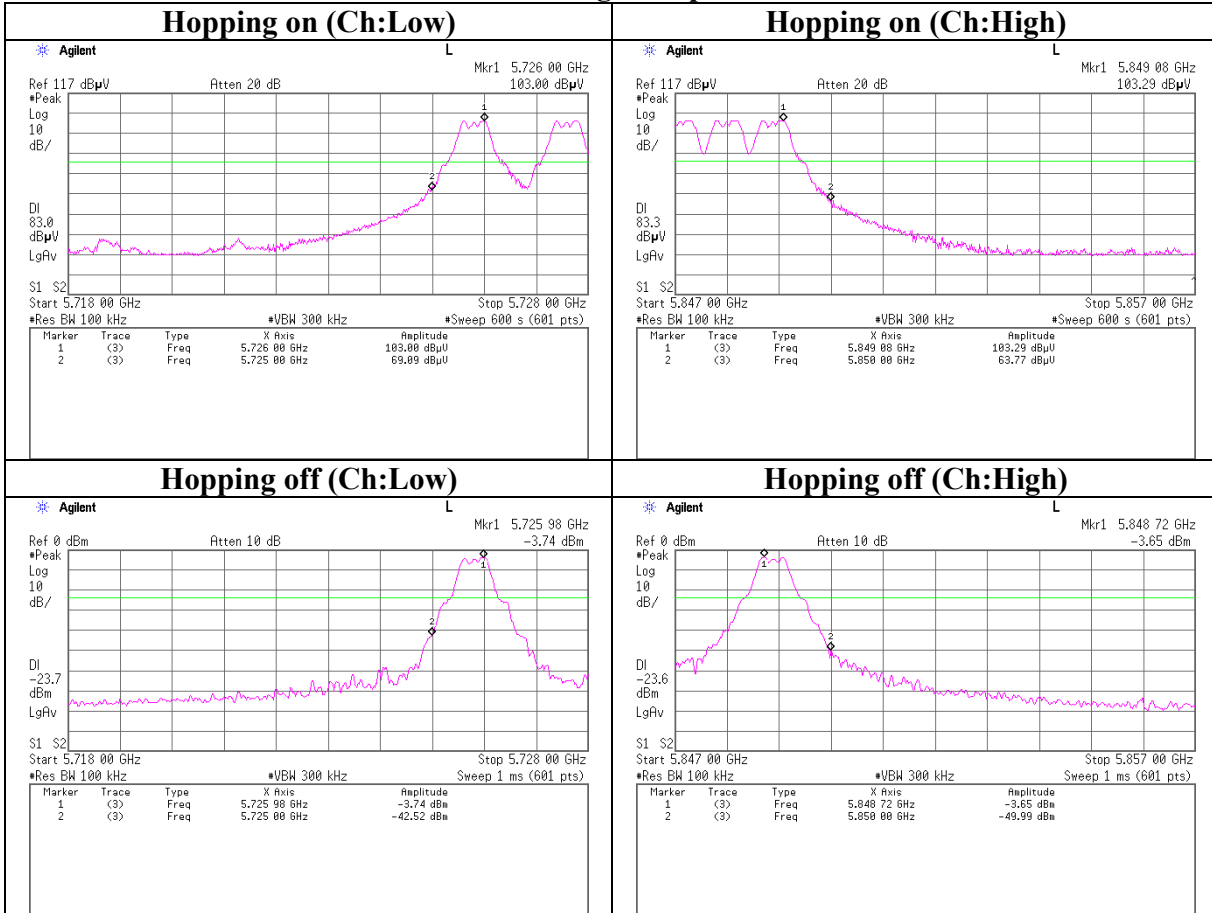

APPENDIX 3: Test instruments

EMI test equipment

Control No.	Instrument	Manufacturer	Model No	Test Item	Calibration Date * Interval(month)
MSA-04	Spectrum Analyzer	Agilent	E4448A	AT	2006/06/02 * 12
MSA-05	Spectrum Analyzer	Advantest	R3273	AT	2006/03/25 * 12
MCC-06	Microwave Cable 1G-26.5GHz	Suhner	SUCOFLEX 104	AT	2006/02/02 * 12
MAT-21	Attenuator (20dB)(above1GHz)	HIROSE ELECTRIC CO.,LTD.	AT-120	AT	2006/01/10 * 12
MRENT-34	Power sensor	Anritsu	MA2411B	AT	2006/04/25 * 12
MRENT-35	Power Meter	Anritsu	ML2496A	AT	2006/04/25 * 12
MOS-01	Digital Humidity Indicator	N.T	NT-1800	AT	2004/11/25 * 24
MAEC-04	Anechoic Chamber	TDK	Semi Anechoic Chamber 3m	RE	2006/03/06 * 12
MOS-15	Thermo-Hygrometer	Custom	CTH-180	RE	2006/01/19 * 24
MSA-03	Spectrum Analyzer	Agilent	E4448A	RE	2005/09/16 * 12
MHA-06	Horn Antenna	Schwarzbeck	BBHA9120D	RE	2006/01/09 * 12
MCC-57	Microwave Cable	Suhner	SUCOFLEX104	RE	2006/04/15 * 12
MPA-12	MicroWave System Amplifier	Agilent	83017A	RE	2006/03/27 * 12
MHF-11	High Pass Filter	TOKIMEC	TF37NCCC	RE	2006/06/21 * 12
MSTW-14	EMI measurement program	TSJ	TEPTO-DV	RE	-
MHA-02	Horn Antenna	EMCO	3160-09	RE(MW)	2006/01/09 * 12
MSA-05	Spectrum Analyzer	Advantest	R3273	RE	2006/05/20 * 12
MTR-02	Test Receiver	Rohde & Schwarz	ESCS30	RE	2006/02/02 * 12
MCC-50	Coaxial cable	UL Apex	-	RE	2006/03/09 * 12
MLA-08	Logperiodic Antenna	Schwarzbeck	UKLP9140-A	RE	2006/01/29 * 12
MPA-14	Pre Amplifier	SONOA INSTRUMENT	310	RE	2006/03/25 * 12
MCC-05	Microwave Cable 1G-40GHz	Storm	421-011 (90-1394-079)	RE	2006/01/04 * 12
MCC-27	Microwave Cable 1G-40GHz	Suhner	SUCOFLEX101	RE	2005/08/30 * 12
MSA-04	Spectrum Analyzer	Agilent	E4448A	RE	2006/06/02 * 12
MPA-03	Microwave System Power Amplifier	Agilent	83050A	RE	2006/05/16 * 12
MHA-03	Horn Antenna	EMCO	3160-10	RE(MW)	2006/01/09 * 12
MLS-07	LISN(AMN)	Schwarzbeck	NSLK8127	CE (EUT)	2006/02/06 * 12
MRENT-39	Spectrum Analyzer	Advantest	R3273	CE	2006/07/25 * 12
MTR-03	Test Receiver	Rohde & Schwarz	ESCI	CE	2006/03/04 * 12
MAEC-02	Anechoic Chamber	TDK	Semi Anechoic Chamber 3m	CE	2006/04/10 * 12
MOS-02	Digital Humidity Indicator	N.T	NT-1800	CE	2004/11/25 * 24
MCC-13	Coaxial Cable	Fujikura/Agilent	-	CE	2006/02/23 * 12
MJG-52	Conversion adapter	SE	RW-P003	CE	-
MLS-06	LISN(AMN)	Schwarzbeck	NSLK8127	CE (AE)	2006/02/06 * 12
MTA-06	Terminator	MCL	BTRM-50	CE	2006/02/06 * 12

All equipment is calibrated with traceable calibrations. Each calibration is traceable to the national or international standards. Test Item:

CE: AC Main Conducted Emission, Antenna Terminal Conducted Spurious Emission, Maximum Peak Output Power, Carrier Frequency Separation, 20dB Bandwidth, Number of Hopping Frequency, Dwell time

RE: Radiated Spurious Emission

UL Apex Co., Ltd.

Head Office EMC Lab.

4383-326 Asama-cho, Ise-shi, Mie-ken 516-0021 JAPAN

Telephone : +81 596 24 8116

Facsimile : +81 596 24 8124

MF060b(14.06.06)