

APPENDIX 4: Photographs of test setup

1. Photographs of EUT and Antenna

Ant.1

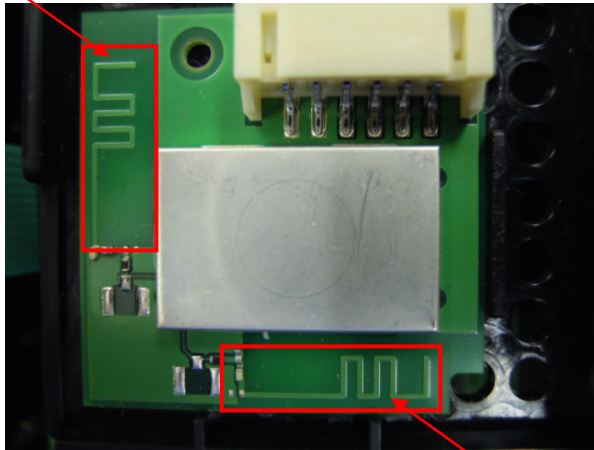

Ant.0

2. Information for tested Host device

The Thermal printer is host device for EUT.

The SAR test was performed in thermal printer of representation.

The details of the tested thermal printer are shown below.

Type of Equipment	:	Thermal Printer
Model No.	:	RJ-4040
Serial No.	:	U63111-G1G781627
Rating	:	DC14.4V for Rechargeable Battery
Battery	:	Rechargeable Battery (Li-ion) (Model No.: PA-BT-4000LI) DC14.4V/ 1800mAh 26Wh
Size	:	162(W)x77(H)x176(D)
Accessory	:	Belt clip
Manufacture	:	BROTHER INDUSTRIES, LTD.
The shortest distance between surface of host device and antenna	:	8.3mm

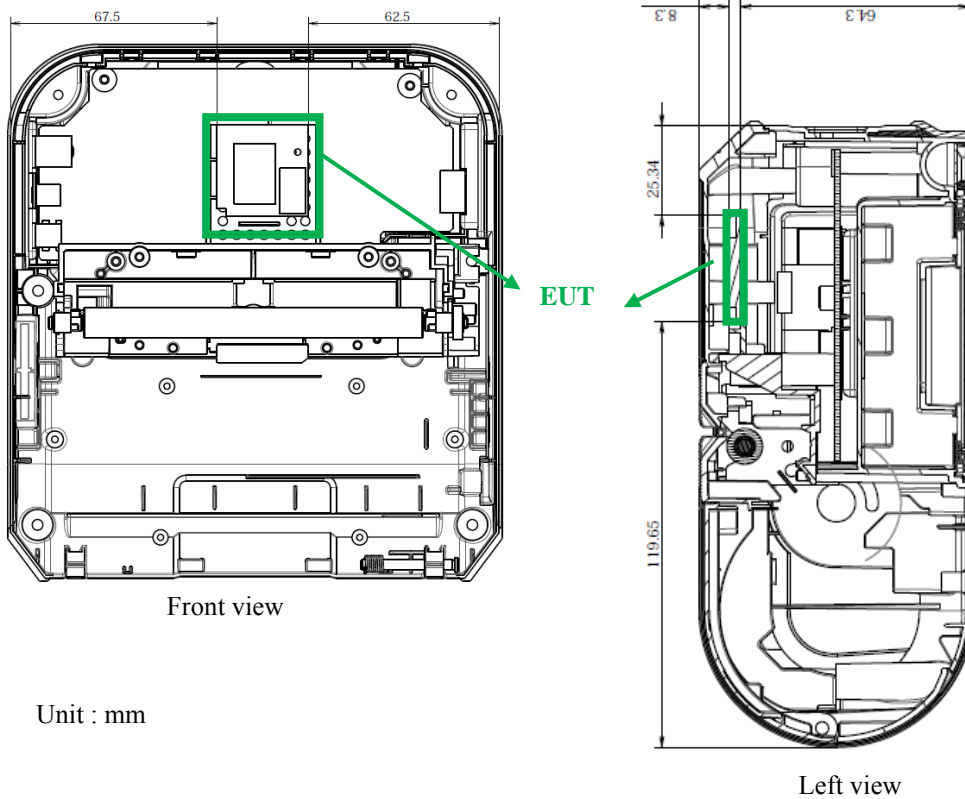

UL Japan, Inc.

Head Office EMC Lab.

4383-326 Asama-cho, Ise-shi, Mie-ken 516-0021 JAPAN

Telephone: +81 596 24 8116

Facsimile: +81 596 24 8124

Top



Right



Front



Left



Bottom



Rear



3. Photographs of setup



Rear



Left

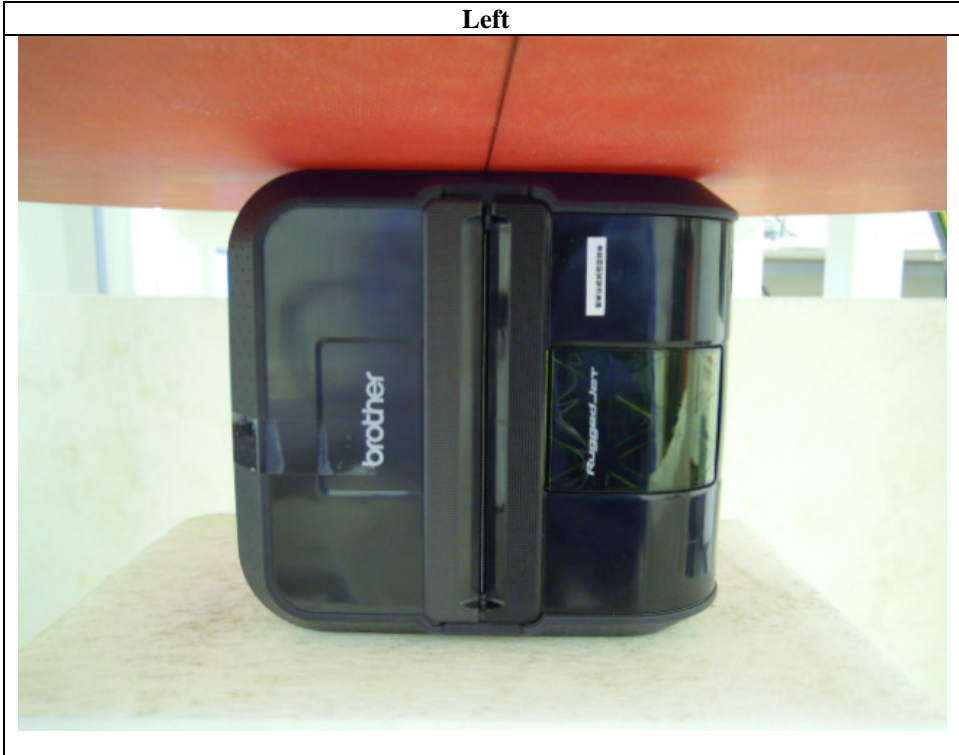

UL Japan, Inc.

Head Office EMC Lab.

4383-326 Asama-cho, Ise-shi, Mie-ken 516-0021 JAPAN

Telephone: +81 596 24 8116

Facsimile: +81 596 24 8124

Right



UL Japan, Inc.

Head Office EMC Lab.

4383-326 Asama-cho, Ise-shi, Mie-ken 516-0021 JAPAN

Telephone: +81 596 24 8116

Facsimile: +81 596 24 8124

Top



Bottom



UL Japan, Inc.

Head Office EMC Lab.

4383-326 Asama-cho, Ise-shi, Mie-ken 516-0021 JAPAN

Telephone: +81 596 24 8116

Facsimile: +81 596 24 8124

Front 5mm

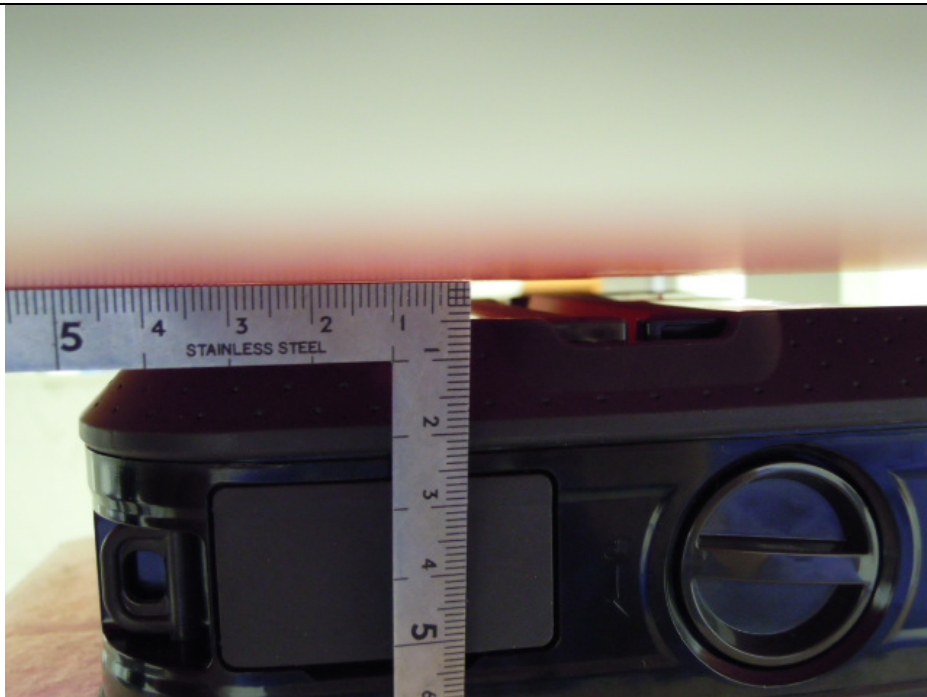

Front 10mm

