

VX 680

Installation Guide



VX 680 Installation Guide
© 2011 VeriFone, Inc.

All rights reserved. No part of the contents of this document may be reproduced or transmitted in any form without the written permission of VeriFone, Inc.

The information contained in this document is subject to change without notice. Although VeriFone has attempted to ensure the accuracy of the contents of this document, this document may include errors or omissions. The examples and sample programs are for illustration only and may not be suited for your purpose. You should verify the applicability of any example or sample program before placing the software into productive use. This document, including without limitation the examples and software programs, is supplied "As-Is."

VeriFone, the VeriFone logo, Omni, VeriCentre, and Verix are registered trademarks of VeriFone. Other brand names or trademarks associated with VeriFone's products and services are trademarks of VeriFone, Inc.

All other brand names and trademarks appearing in this manual are the property of their respective holders.

Comments? Please e-mail all comments on this document to your local VeriFone Support Team.

DRAFT
REVISION C.4



VeriFone, Inc.
2099 Gateway Place, Suite 600
San Jose, CA, 95110 USA
1-800-VERIFONE

www.verifone.com



PREFACE 7

Audience 7

Organization 7

Related Documentation 7

Conventions and Acronyms 8

 Document Conventions 8

 Acronym Definitions 9

CHAPTER 1
Terminal Overview

Features at a Glance 12

Features and Benefits 12

 Exceptional Ease of Use 12

 Performance and Durability 13

 Security 13

 Contactless Capability 13

 Communication Technology 13

CHAPTER 2
Terminal Setup

Selecting Terminal Location 16

 Environmental Factors 16

 Electrical Considerations 16

 Considerations for Bluetooth® AP Charging Base Station 16

Unpacking the Shipping Carton 17

Examining Terminal Features 18

 Front Panel 19

Examining Connection Ports 19

 Power Adapter Cable 20

 USB Host Cable 20

 Multi-port Adapter 21

 USB Modem Dongle 21

 USB Serial Dongle (RS-232 UART) 22

 Bluetooth® Access Point (AP) Charging Base (Bluetooth® Interface) 22

Establishing Telephone Line Connections 23

VX 680 Bluetooth® Support 24

 Bluetooth® AP Charging Base Station Connector Sockets 25

 Mounting the Bluetooth® AP Charging Base Station 26

 Power Connection to the Bluetooth® AP Charging Base Station 27

 Telephone Line Connection to the Bluetooth® AP Charging Base Station 28

Installing the Paper Roll 29

Installing/Replacing MSAM Cards 31

Installing the SIM or R-UIM Card (GPRS and CDMA Models) 33

Installing/Replacing SD Card 35

Using the Smart Battery 36

 Smart Battery Features 36

Battery Behavior (No Power Cable) 37

 Manual Startup 37

Manual Shutdown	37
Installing the Smart Battery	38
Removing the Smart Battery	38
Connecting the Terminal Power Pack	39
Charging the Smart Battery	40
Battery Life	40
Using the Base Station	41
Standard Base Station	41
Full-Featured Base Station	41
Bluetooth® Access Point Charging Base	42
Mounting the Terminal Onto the Base Station	43
Attaching the USB Dongles to the Base Station	44
Charging the Spare Battery on the Base Station	44
Conducting Wireless Transactions	46
Conducting Smart Card Transactions	46
Conducting Bluetooth® Transactions	46
Using the Magnetic Card Reader	47
Using the Stylus	47
CHAPTER 3	
Specifications	
Power	49
DC Power Pack	49
Temperature	49
External Dimensions	49
CHAPTER 4	
Maintenance	
Cleaning the Terminal	51
Terminal Contacts	51
Smart Card Reader	51
CHAPTER 5	
VeriFone Service and Support	
Returning a Terminal or Smart Battery for Service	53
Accessories and Documentation	55
Power Pack	55
Printer Paper	55
VeriFone Cleaning Kit	55
Spare Battery	55
USB Host Cable	55
Modem Dongle	55
Serial Dongle	55
Telephone Line Cable	55
Documentation	56

CHAPTER 6	
Troubleshooting	
Guidelines	
Terminal Does Not Start	57
Terminal Display Does Not Show Correct/Readable Info.	57
Smart Battery Does Not Charge.	58
Spare Battery in Base Station Does Not Charge	58
Blank Display	58
Terminal Does Not Dial Out	59
Printer Does Not Print	59
Printer Paper Jam	59
Keypad Does Not Respond	60
Transactions Fail to Process	60
INDEX	63



This guide is your primary source of information for setting up and installing the VX 680 terminal.

Audience

This guide is useful for anyone installing and configuring a VX 680 terminal. Basic descriptions of the terminal features are also provided.

Organization

This guide is organized as follows:

[Chapter 1, Terminal Overview](#). Provides an overview of the VX 680 terminal.

[Chapter 2, Terminal Setup](#). Explains how to set up and install the VX 680 terminal. Provides information on how to select a location, establish power and telephone line connections, and how to configure optional peripheral devices.

[Chapter 3, Specifications](#). Discusses power requirements and dimensions of the VX 680 terminal.

[Chapter 4, Maintenance](#). Explains how to maintain your VX 680 terminal.

[Chapter 5, VeriFone Service and Support](#). Provides information on contacting your local VeriFone representative or service provider, and information on how to order accessories or documentation from VeriFone.

[Chapter 6, Troubleshooting Guidelines](#). Provides troubleshooting guidelines, should you encounter a problem in terminal installation and configuration.

Related Documentation

To learn more about the VX 680 terminal, refer to the following set of documents:

VX 680 Certifications and Regulations Sheet	VPN DOC268-001-EN-A
VX 680 Quick Installation Guide	VPN DOC268-002-EN-A
VX 680 Reference Guide	VPN DOC268-004-EN-A
VX 680 Standard Base Quick Installation Guide	VPN DOC268-005-EN-A
VX 680 Full-Featured Base and Dongle Quick Installation Guide	VPN DOC268-006-EN-A
VX 680 CDMA Certifications and Regulations Sheet	VPN DOC268-012-EN-A
Verix eVo Volume I: Operating System Programming Manual	VPN DOC00301
Verix eVo Volume II: Operating System and Communications Programmers Manual	VPN DOC00302
Verix eVo Volume III: Operating System Programming Tools Reference Manual	VPN DOC00303



Conventions and Acronyms

This section describes the conventions and acronyms used in this guide.

Document Conventions

Various conventions are used to help you quickly identify special formatting. [Table 1](#) describes these conventions and provides examples of their use.

Table 1 Document Conventions

Convention	Meaning	Example
Blue	Text in blue indicates terms that are cross referenced.	See Conventions and Acronyms .
<i>Italics</i>	Italic typeface indicates book titles or emphasis.	You <i>must</i> install a roll of thermal-sensitive paper in the printer.
Courier	The courier type face is used while specifying onscreen text, such as text that you would enter at a command prompt, or to provide an URL.	<code>http://www.verifone.com</code>
	The pencil icon is used to highlight important information.	RS-232-type devices do not work with the PINpad port.
	The caution symbol indicates possible hardware or software failure, or loss of data.	The terminal is not waterproof or dustproof, and is intended for indoor use only.
	The lightning symbol is used as a warning when bodily injury might occur.	Due to risk of shock do not use the terminal near water.

Acronym Definitions Various acronyms are used in place of the full definition. [Table 2](#) presents acronyms and their definitions.

Table 2 Acronym Definitions

Acronym	Definitions
AC	Alternating Current
BT	Bluetooth
CDMA	Code Division Multiple Access
EMV	Europay MasterCard and VISA
GPRS	General Packet Radio Service
GSM	Global System for Mobile Communication
HDMI	High-Definition Multimedia Interface
ITP	Internal Thermal Printer
LCD	Liquid Crystal Display
LED	Light Emitting Diode
MRA	Merchandise Return Authorization
MSAM	Micromodule-Size Security Access Module
PED	PIN Entry Device
PIN	Personal Identification Number
QVGA	Quarter Video Graphics Array
RJ45	Registered Jack 45
RS-232	Recommended Standard 232
R-UIM	Removable User Identity Module
SAM	Security Access Module
SD	Secure Digital
SIM	Subscriber Identity Module
TFT	Thin Film Transistor
UART	Universal Asynchronous Transmitter/Receiver
USB	Universal Serial Bus
VPN	VeriFone Part Number
Wi-Fi	Wireless Fidelity

Terminal Overview

This chapter provides a brief description of the VX 680 terminal. This terminal features a large color and touchscreen display, fast processor, abundant memory, PCI 2.0 and PCI 3.0 security, and integrated contactless features.

The VX 680 terminal is a portable, battery-powered device designed to fit comfortably during handheld consumer-facing applications. It features a vibrantly colored 3.5" TFT QVGA display and a backlit spill-resistant keypad. It supports a variety of communications technologies including: 802.11g Wi-Fi with WPA2 security support, GPRS, Bluetooth® wireless technology, and CDMA.

NOTE



VeriFone ships variants of the VX 680 terminal for different markets. Your terminal may have a different configuration. The following devices may or may not be present: a smart card reader, none or three MSAM cardholders, and a SIM/R-UIM cardholder.



Figure 1 The VX 680 Terminal

Features at a Glance

The following are the features of VX 680:

-
- 400 MHz ARM11 RISC processor delivers power and usability in a convenient “hand-over” design.
 - Multi-application operating environment.
 - Advanced memory architecture to meet tomorrow’s needs with support for 192 MB.
 - Backward compatibility with VeriFone solutions help reduces development costs.
 - Drop-resistant design minimizes breakage.
 - 32-bit processing and multi-tasking capabilities.
 - Security architecture exceeds specifications for PCI-PED and sophisticated file authentication.
 - Securely supports and runs payment and value-added applications along with signature capture.
 - Offers unsurpassed performance on EMV smart card transactions
 - Max UI design provides large 3.5” color QVGA display, and large blue backlit keys for easier viewing.
 - Adds vibrant color and touchscreen to the smallest purpose-built wireless payment device.
 - Multiple connectivity and Contactless options.
 - Spill-resistant design forces liquid down and off the front of the terminal.
 - USB support for VeriFone peripheral devices.
-

Features and Benefits

VX 680 terminals provide the right combination of features and functions including a triple-track magnetic stripe card reader, smart card reader, integrated PIN pad, color touchscreen display, optional contactless support, and a quiet yet fast internal thermal printer (ITP).

Exceptional Ease of Use

- Lightweight, tapered design, compact, stylish and the ergonomic balance allows convenient terminal hand-off to the consumer for PIN entry or other input.
- Large 3.5” color TFT display for boundless application possibilities and easy readability under various lighting conditions.
- Large, blue backlit keys provide tactile response to simplify usage and minimize finger slips.
- 38 mm diameter paper roll with a trouble-free, drop-in, “clam shell” loading and dual tear bar that allow receipts to be torn in any direction.
- Quiet and fast integrated thermal printer with a rear placement to maximize the user interface area.
- Vertical magnetic stripe card reader with an extended blade for optimal card reading.
- Touchscreen for icon-based applications or electronic signature capture support.
- Optional hands-free holster is available that fits the server’s or clerk’s belt so that the POS device can be quickly removed and easily handed to the customer.

Performance and Durability

- Fast transactions due to powerful 400 MHz ARM11 processor.
- High-capacity 7.2 V 1800 mA Li-ion battery.
- Standard base for drop-and-go charging or optional full-featured base with spare battery charging.
- USB ports for connection to supported USB peripherals.
- Rounded corners and drop resistant to 3 feet on concrete floor to minimize breakage.
- 192 MB of memory with optional removable SD flash memory.

Security

- PCI PED 2.0 and PCI PED 3.0 approved for debit and other PIN-based transactions.
- EMV Level 1 and 2 Type Approval.
- Tamper-resistant construction, SSL protocols, and VeriShield file authentication.
- Latest WPA2 Wi-Fi security and supports VeriShield Protect encryption implementations.

Contactless Capability

- Advanced contactless architecture that future-proofs investment with a single contactless interface (SingleCI), SoftSAMs, and side-by-side application architecture.
- On-screen tap zone (CTLS logo) for optimized user experience
- Contactless version accepts EMV and mag-stripe contactless payments as well as PIN-based transactions.

Communication Technology

- VX 680 GPRS and 3G: Long-range wireless payment for retailers that have no physical location limitations.
- VX 680 CDMA: Long-range wireless payment for Non-GPRS coverage areas.
- VX 680 Wi-Fi: Ideal for retailers that need multiple wireless devices and have existing IP infrastructure.
- VX 680 Bluetooth®: Simple, plug-and-play installation for locations that need short-range wireless capability.



Terminal Setup

This chapter describes the terminal setup procedures. You will learn about:

- Selecting Terminal Location.
- Unpacking the Shipping Carton.
- Examining Terminal Features.
- Examining Connection Ports.
- Establishing Telephone Line Connections.
- VX 680 Bluetooth® Support.
- Installing the Paper Roll.
- Installing and Replacing MSAM Cards.
- Installing the SIM or R-UIM Card (GPRS and CDMA Models).
- Installing and Replacing SD Card.
- Installing the Smart Battery.
- Using the Smart Battery.
- Battery Behavior (No Power Cable).
- Removing the Smart Battery.
- Charging the Smart Battery.
- Connecting the Terminal Power Pack.
- Using the Base Station.
- Mounting the Terminal Onto the Base Station.
- Attaching the USB Dongles to the Base Station.
- Charging the Spare Battery on the Base Station.
- Conducting Wireless Transactions.
- Conducting Smart Card Transactions.
- Conducting Bluetooth® Transactions
- Using the Magnetic Card Reader.
- Using the Stylus.

Selecting Terminal Location

Use the following guidelines when selecting a location for your VX 680 terminal.

Environmental Factors

- The VX 680 unit is a portable terminal. Select a flat support surface, such as a countertop or table, to keep the terminal safe in between uses.
- Do not use the terminal where there is high heat, dust, humidity, moisture, or caustic chemicals or oils.
- Keep the terminal away from direct sunlight and anything that radiates heat, such as a stove or motor.
- Do not use the terminal outdoors.



The terminal is not waterproof or dustproof, and is intended for indoor use only. Any damage to the unit from exposure to rain or dust may void any warranty.

Electrical Considerations

- Avoid using this product during electrical storms.
- Avoid locations near electrical appliances or other devices that cause excessive voltage fluctuations or emit electrical noise (for example, air conditioners, electric motors, neon signs, high-frequency or magnetic security devices, or computer equipment).
- Do not use the terminal near water or in moist conditions.

Considerations for Bluetooth® AP Charging Base Station

The Bluetooth® AP Charging Base Station requires the following:

- A power source within two meters.
- A telephone socket within three meters (for PSTN version).
- A location with minimal obstruction for communicating with terminals.
- It is recommended that the Bluetooth® AP Charging Base Station be installed two meters from the ground to allow the LEDs to be seen, and the state of the connection to be confirmed.

Unpacking the Shipping Carton

Open the shipping carton and carefully inspect its contents for possible tampering or shipping damage. The VX 680 device is a secure product and any tampering may cause the terminal to cease to function properly.

To unpack the Shipping Carton

- 1 Remove and inspect the following items:
 - Terminal
 - Power pack
 - Telephone line cable
 - Power cable
 - Battery pack
 - Paper roll
- 2 Remove all plastic wrapping from the terminal and other components.
- 3 Remove the clear protective film from the LCD screen.



Do not use a terminal that has been damaged or tampered with. The VX 680 terminal comes equipped with tamper-evident labels. If a label or component appears damaged, please notify the shipping company and your VeriFone representative or service provider immediately.

- 4 Save the shipping carton and packing material for future repacking or moving the terminal.

Examining Terminal Features

Before you continue the installation process, notice the features of the VX 680 terminal (see Figure 2).

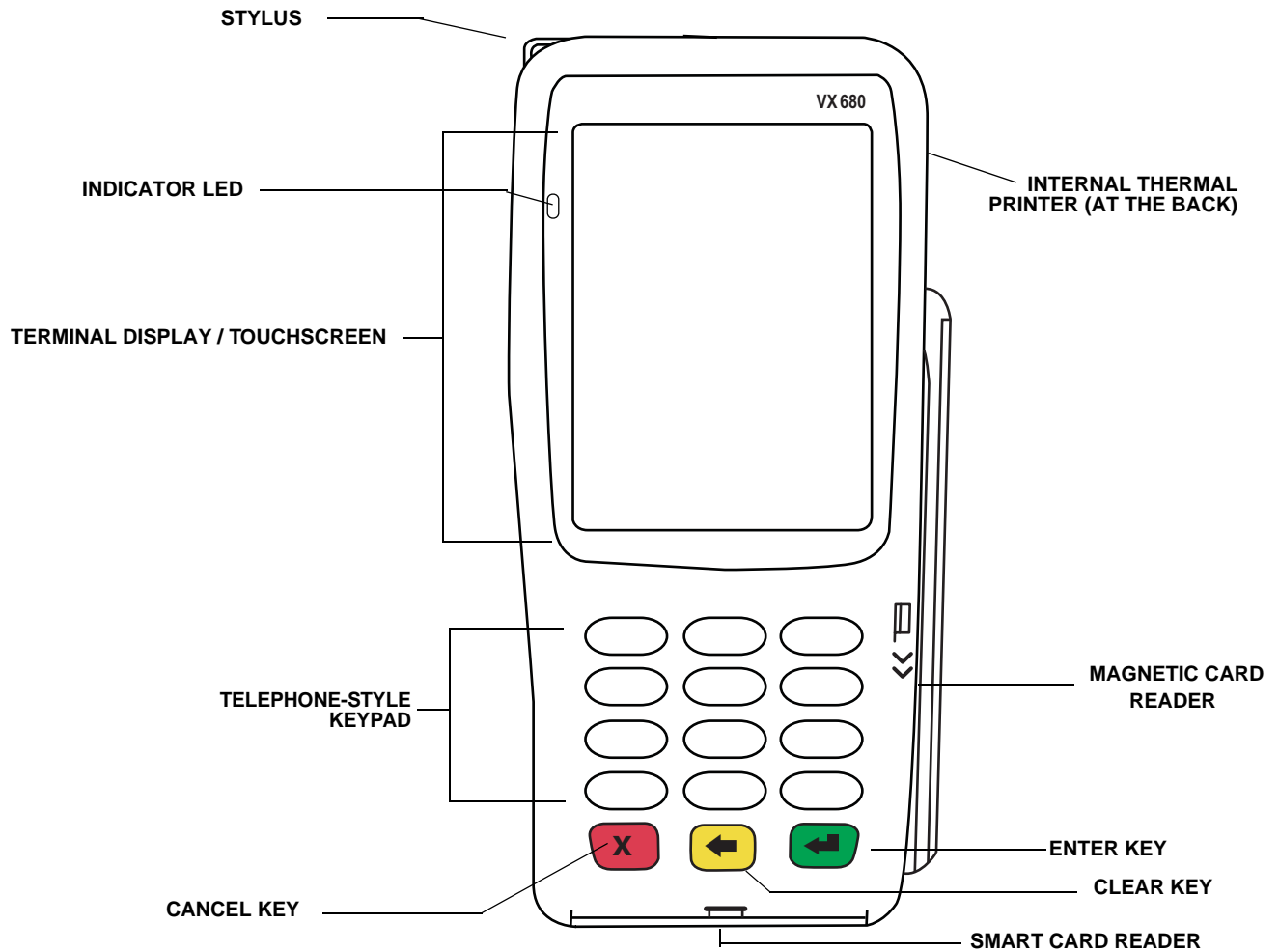

Figure 2 VX 680 Terminal Features (Front Panel)

Front Panel The front panel includes the following features:

- A Large 3.5" color TFT and touchscreen display.
- Two types of keys:
 - a** A 12-key, **telephone-style keypad** (keypads may vary in style).
 - b** Three **color-coded function keys** below the keypad (from left to right: CANCEL, CLEAR, ENTER).
- A **magnetic card reader**, built into the right side. Swipe the card using the proper direction, with the magnetic stripe down and facing inward, toward the keypad.
- A green **indicator LED** indicates power is ON.
- An **internal thermal printer** at the back of the terminal.
- A **smart card reader**, built into the front of the terminal. For directions on how to use a smart card, see [Conducting Smart Card Transactions](#).
- A **stylus**, inserted on top of the terminal above the screen.
- A **SAM (security access module) compartment**, built into the bottom of the terminal inside the printer compartment. The VX 680 terminal contains an MSAM cardholder to support stored-value card programs or other merchant card requirements.



VeriFone ships variants of the VX 680 terminal for different markets. Your terminal may have a different configuration. The following devices may or may not be present: a smart card reader, or an MSAM cardholder. However, the basic processes described in this guide remain the same, regardless of terminal configuration.

Examining Connection Ports

The VX 680 terminal has one primary port that supports different peripherals through the use of various cables.

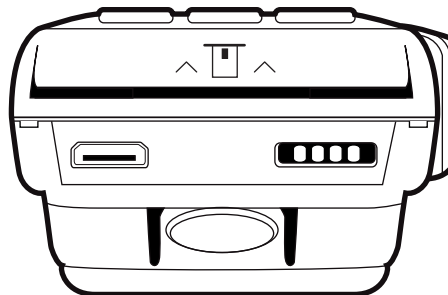

Figure 3 The VX 680 Primary Port (Bottom View)

Power Adapter Cable Each VX 680 terminal comes with power adapter cable (VPN CBL268-004-01-A) that completes the connection between the power pack and the terminal.

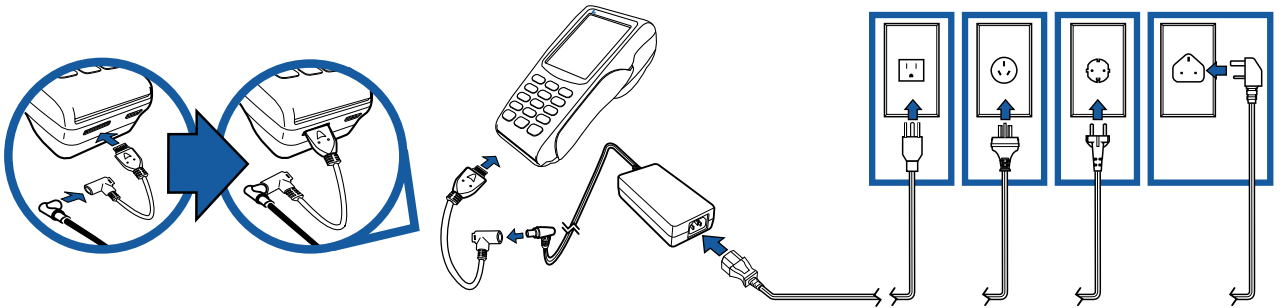

Figure 4 Power Adapter Cable Connection to a VX 680 Terminal

USB Host Cable The VX 680 terminal also provides a 2 wire USB host port (VPN CBL268-003-01-A) for supporting external peripherals. A connector adaptor provides for standard USB host connection for the Modem Dongle or the RS-232 UART dongle.

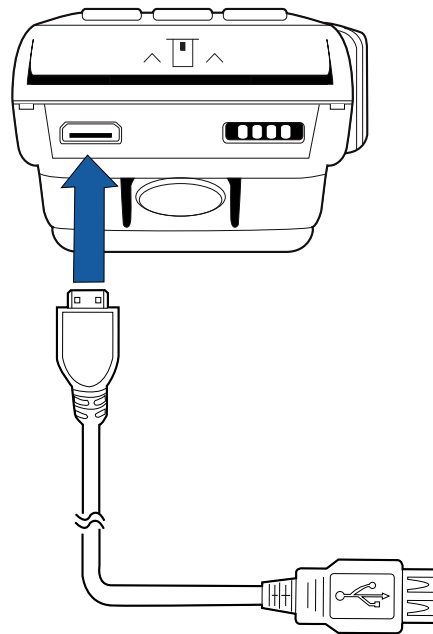

Figure 5 USB Host Cable Connection to a VX 680 Terminal

Multi-port Adapter An optional multi-port adapter (VPN 08643-01-R) provides connectivity for power, USB host, USB device, and COM1 (RS-232 UART). This cable is used only for deployment or development purposes.

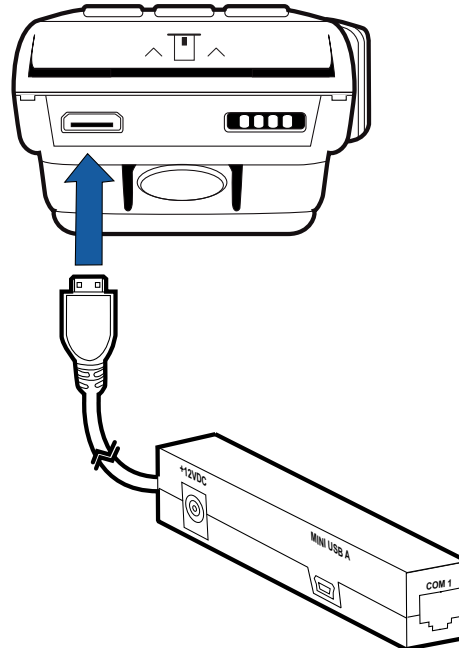

Figure 6 Multi-port Adapter Connection to a VX 680 Terminal



NOTE Other cables are available for different purposes. Check with your local VeriFone representative for further information.

USB Modem Dongle Use the USB Modem Dongle (VPN 24123-04-R) to provide the VX 680 terminal with modem communication over a telephone line at speeds of up to 33,600 bps. It can also be connected to the full-featured Base Station (see [Attaching the USB Dongles to the Base Station](#)).



NOTE The VX 680 WiFi/BT variant does not support the USB modem dongle connection.

USB Serial Dongle (RS-232 UART)

The USB Serial Dongle (VPN 24122-04-R) is designed to accommodate the RJ45 connector and it may be purchased with the VX 680 terminal. The USB Serial Dongle can also be connected to the full-featured Base Station (see [Attaching the USB Dongles to the Base Station](#)).



NOTE A Base Station may be purchased with the VX 680 terminal or purchased as a separate option. The full-featured Base Station has two USB host ports for external dongles as well as a battery charger slot for charging an extra Li-ion battery pack. A standard Base Station does not have any USB ports and is capable of charging the terminal only and not the extra battery pack.



CAUTION The Modem Dongle and Serial Dongle are intended for use with the VX 680 terminal and Base Station only. They should not be installed or used with any equipment other than the VX 680 terminal or Base Station.

Bluetooth® Access Point (AP) Charging Base (Bluetooth® Interface)

The Bluetooth® AP Base Station relays wireless data received from the VX 680 terminal via modem and then transmits back the response to the terminal.

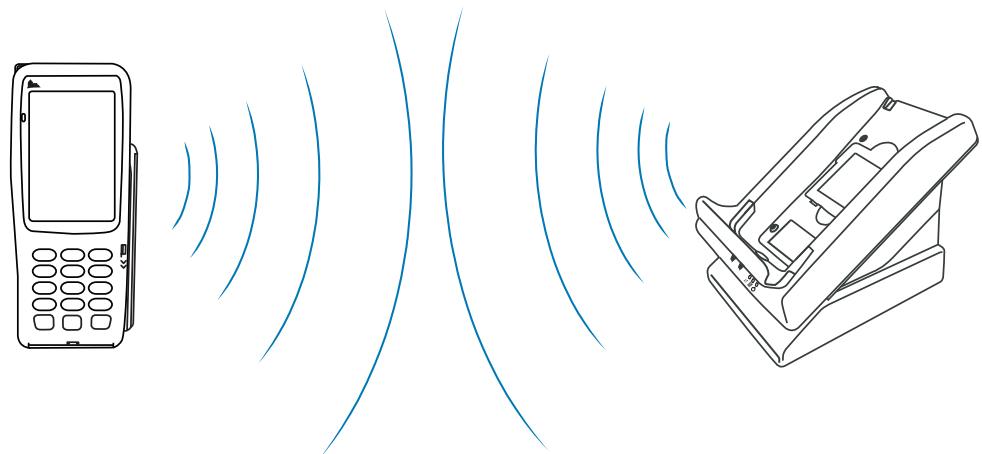

Figure 7 VX 680 Terminal communicating with a Bluetooth® Access Point (AP) Charging Base

To improve the range performance of the VX 680 terminal, the Bluetooth AP Base Station should be placed in a position that will service all of the card payment areas in your premises. The ideal placement is to position the base station within line of sight of all areas of card acceptance.

Establishing Telephone Line Connections

The VX 680 supports telephone line connections through a USB Modem Dongle connected to the phone cable.

To connect a telephone line

- 1 Connect one end of the telephone cable to the USB Modem Dongle.
- 2 Connect the USB Modem Dongle to the terminal using the mini-HDMI Connector (VPN CBL268-003-01-A).
- 3 Route the other end of the telephone cable directly to a telephone wall jack.

NOTE



The VX 680 WiFi/BT variant does not support the USB modem dongle connection.

WARNING



To reduce the risk of fire, use only No. 26 AWG or larger UL Listed or CSA Certified Telecommunication Line Cable.

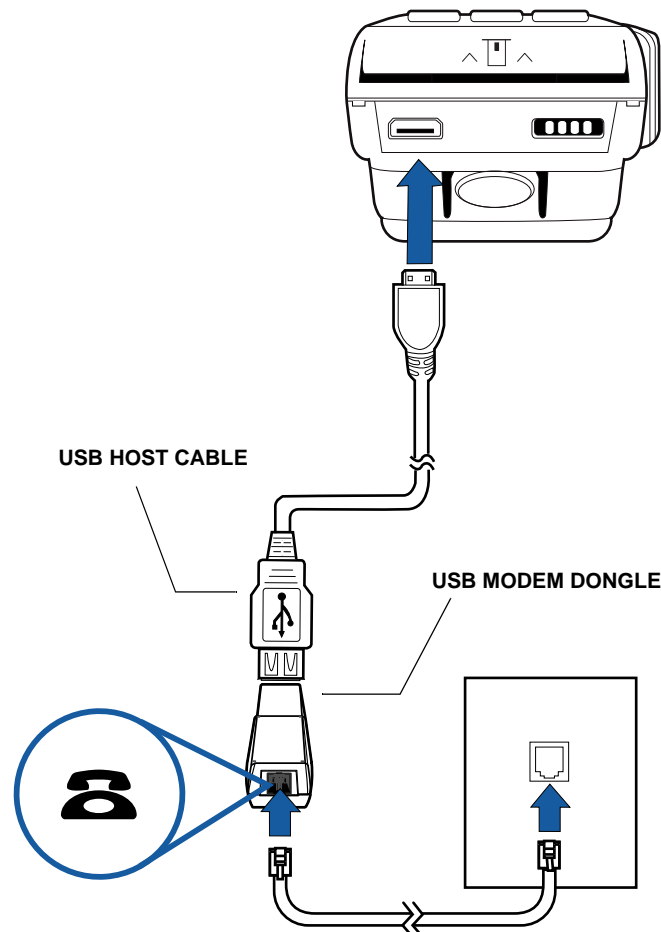

Figure 8 VX 680 USB Modem Dongle Connection

VX 680 Bluetooth® Support

The Bluetooth® variant of the VX 680 terminal uses the Bluetooth® Access Point (AP) Charging Base Station (VeriFone part numbers include XPBS019 for Silicon Labs dial modem; see your VeriFone representative for other available bases) to go online for authorization.

Although up to eight VX 680 terminals can be registered with the same communications device, only one transaction may be undertaken at a time. It is recommended that not more than three terminals be paired with a base station.

The VX 680 terminal's Bluetooth® variant and the Bluetooth® AP Charging Base Station are both Class 1 Bluetooth® devices providing secure radio communication up to 100 meters, unobstructed.

The VX 680 terminal's Bluetooth® variant may be registered (paired) with more than one base station. It must be paired to secure the communication. Using the standard menu options provided in Veri CommsServer, the terminal may easily be switched among paired devices.

Any number of VX 680 terminals may be paired with a single base station but the base station is only able to relay a single transaction at any one time. When more than three terminals are required on a site, additional base stations suitably positioned to obtain maximum radio coverage are recommended.

NOTE

The VX 680 terminal's Bluetooth® variant can only communicate through a base station to which it has been paired.

Bluetooth® AP Charging Base Station Connector Sockets

Communication with the Bluetooth® Base Stations are encrypted according to the Bluetooth® Standard. VX 680 terminals that are not paired cannot communicate with the Bluetooth® AP Charging Base Station.

There are three connector sockets on the Bluetooth® AP Charging Base Station, as shown in [Figure 9](#):

Power Socket

The Bluetooth® AP Charging Base Station is powered using the Plugtop Adapter and must be powered ON at all times once the Bluetooth® AP Charging Base Station has been initialized. The Green LED on the Bluetooth® AP Base Station will be lit when the power supply is connected.

RJ45 Socket

This would be used for connection to a LAN or ISDN.

Modem Socket

The Bluetooth® AP Charging Base Station has a built-in modem for connecting to the standard telephone network. The Amber LED is only lit while the Bluetooth® AP Charging Base Station is online.

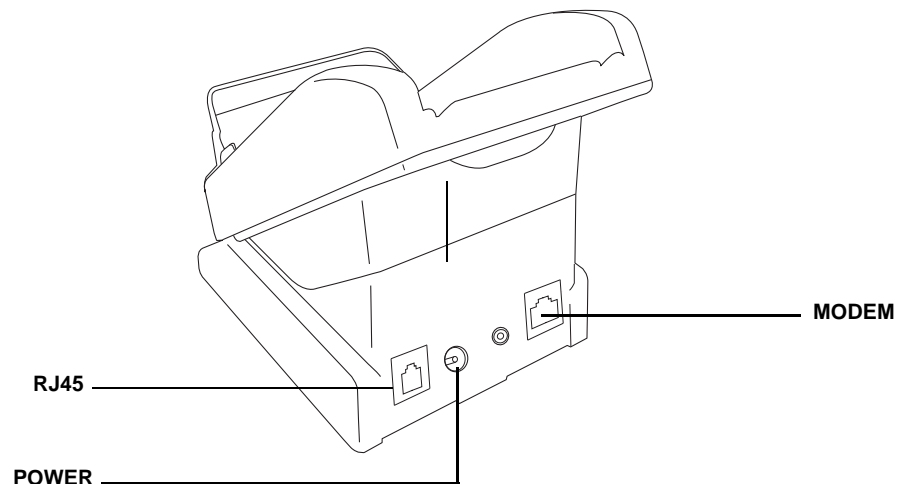

Figure 9 Connection Ports on the Bluetooth® AP Charging Base Station (Bottom View)

Mounting the Bluetooth® AP Charging Base Station

The base station's status is shown on its different LED indicators:

- The green LED indicates that the Bluetooth® AP Charging Base Station is powered ON and capable of communication with other terminals.
- The blue LED is lit when radio connection is made and a paired terminal is communicating with the Bluetooth® AP Charging Base Station.
- The amber LED is lit when the Bluetooth® AP Charging Base Station is online and transmitting data using its internal modem.

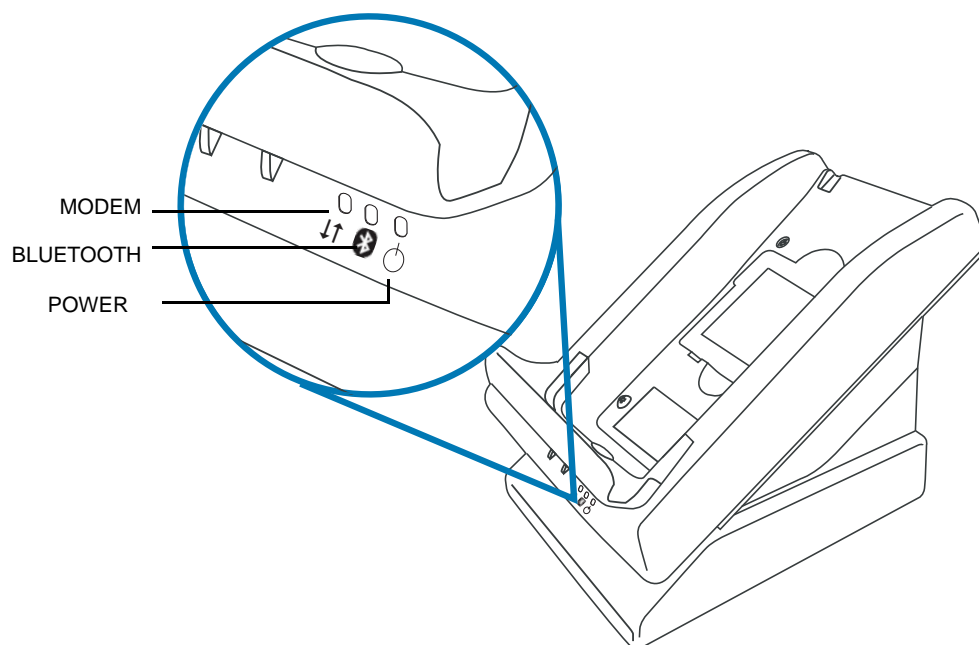

Figure 10 LED indicators on the Bluetooth® AP Charging Base Station

Power Connection to the Bluetooth® AP Charging Base Station

The Bluetooth® AP Charging Base Station comes with a universal-input power pack capable of operating from voltages of 100V-240V AC.

To Connect the Power Pack

- 1 Insert the round barrel connector into the power port on the Bluetooth® AP Charging Base Station, as shown in Figure 11.

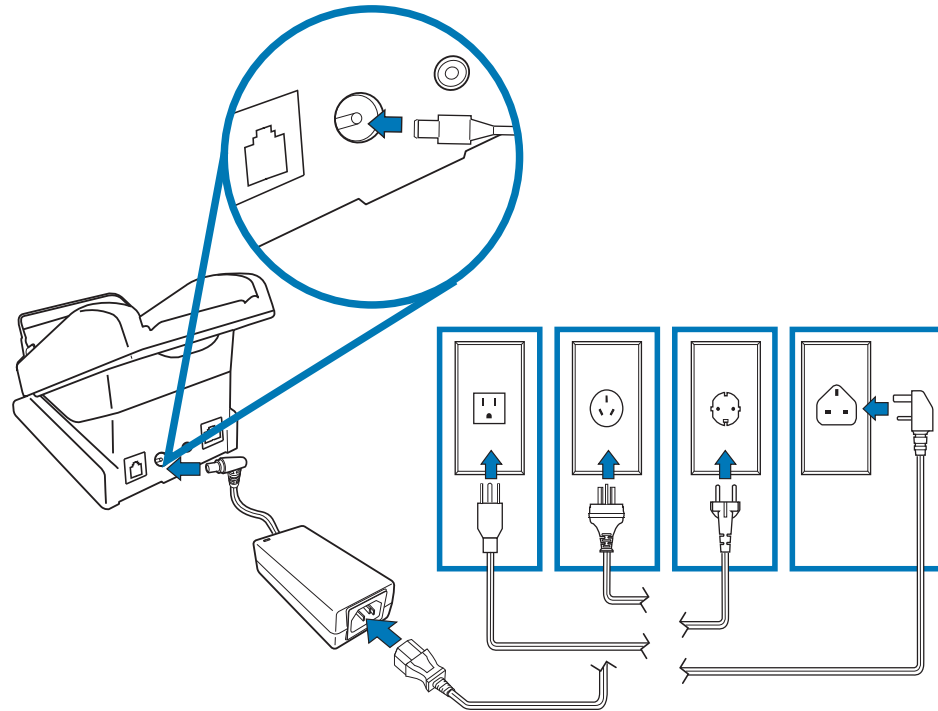

Figure 11 Power Connection to the Bluetooth® AP Charging Base Station

- 2 Insert the AC power cord into the power pack.
- 3 Plug the AC power cord into a wall outlet or powered surge protector.
- 4 Confirm that the Base Station is powered up as indicated by the solid green LED.



WARNING

Do not plug the power pack into an outdoor outlet or operate the terminal outdoors.



NOTE

To protect against possible damage caused by lightning strikes and electrical surges, consider installing a power surge protector.

Telephone Line Connection to the Bluetooth® AP Charging Base Station

The VX 680 supports telephone line connections through a USB Modem Dongle connected to the phone cable. However, the VX 680 WiFi/BT variant does not support this feature.

To connect a telephone line to the Bluetooth® AP Base

- 1 Connect the small connector on the modem cable to the modem port on the Bluetooth® AP Charging Base Station, as shown in Figure 12.
- 2 Plug the modem cable directly to a telephone wall jack or use a 'T' connector if sharing the telephone line with other equipment.

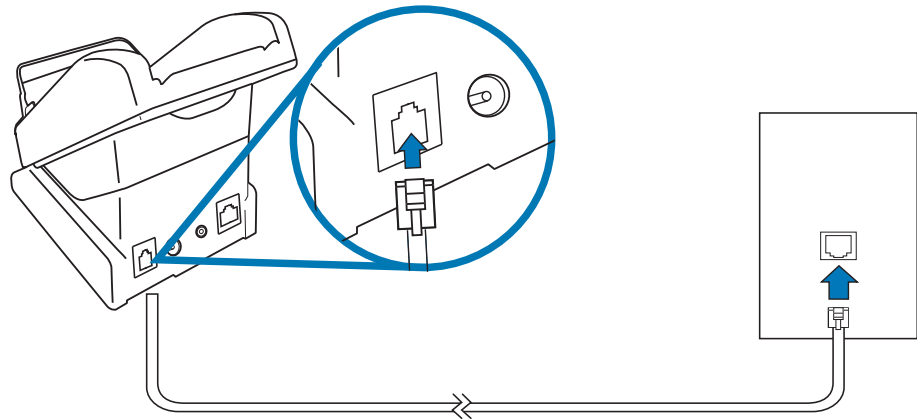

Figure 12 Telephone Line Connection to the Bluetooth® AP Charging Base Station



The Bluetooth® AP Charging Base Station **MUST** be connected to the telephone line at ALL times for all of the terminal's facilities to function properly.

Installing the Paper Roll

A fast, quiet thermal printer is built into the VX 680 terminal. Before you can process transactions that require a receipt or record, you *must* install a roll of thermal-sensitive paper in the printer.

The ITP uses a roll of single-ply, thermal-sensitive paper 57 millimeters (2.24 inches) wide and 38 millimeters in diameter. A pink *out-of-paper* indicator line appears on the edge of the paper approximately 18 inches before the end of the roll. After this line appears, there is enough paper remaining on the roll to conclude at least one transaction.



Poor-quality paper can jam the printer and create excessive paper dust. To order high-quality VeriFone paper, refer to [Accessories and Documentation](#).

Store thermal paper in a dry, dark area. Handle thermal paper carefully: impact, friction, temperature, humidity, and oils affect the color and storage characteristics of the paper.

Never load a roll of paper with folds, wrinkles, tears, or holes at the edges in the print area.

- To Install a Paper Roll**
- 1 Gently pull the latch located on the bottom of the terminal to unlock the paper roll cover.

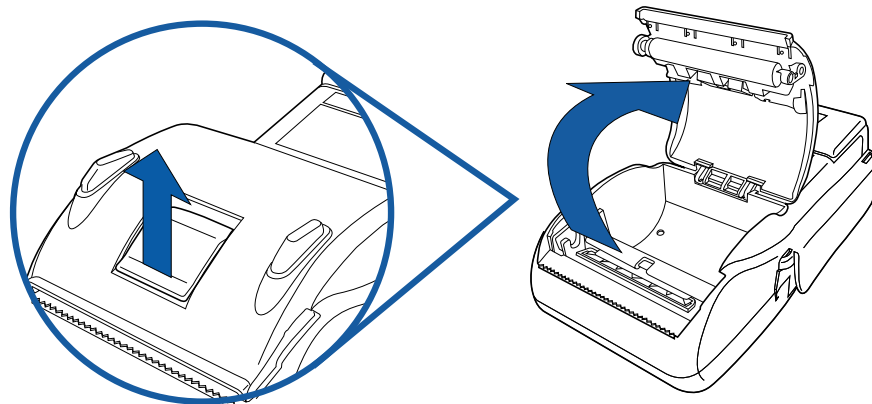

Figure 13 Unlocking the Printer Cover

- 2 Lift the printer cover up and back.
- 3 Remove any partial roll of paper in the printer tray.
- 4 Loosen the glued leading edge of the new roll of paper or remove the protective strip, if applicable. Unwind the paper roll past any glue residue.
- 5 Hold the roll so the paper feeds from the *bottom* of the roll when the terminal is inverted (see [Figure 14](#)).

- 6 Drop the paper roll into the printer tray.

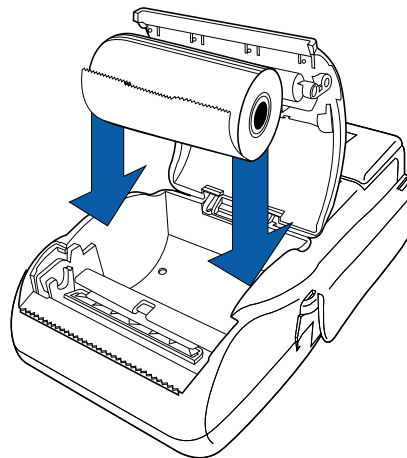

Figure 14 Loading Paper Roll

- 7 Pull paper up past the glue residue on the paper roll.
- 8 Close the paper roll cover by gently pressing directly on the cover until it clicks shut, allowing a small amount of paper past the glue residue to extend outside the printer door.



To prevent damaging the print roller, always gently press down on the paper roll cover to close it.

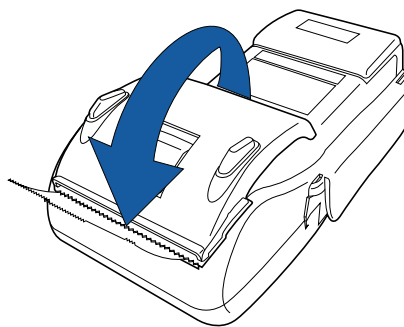

Figure 15 Closing Paper Roll Cover

- 9 Tear the paper off against the serrated plastic strip in the printer.

Installing and Replacing MSAM Cards

When you first receive your VX 680 terminal, you may need to install an MSAM card or you may need to replace old cards.



CAUTION Observe standard precautions when handling electrostatically sensitive devices. Electrostatic discharges can damage this equipment. VeriFone recommends using a grounded anti-static wrist strap.

To Install and Replace MSAM

- 1 Power off the terminal.
- 2 Place the terminal upside down on a soft, clean surface to protect the display from scratches.
- 3 Unlock the printer cover.

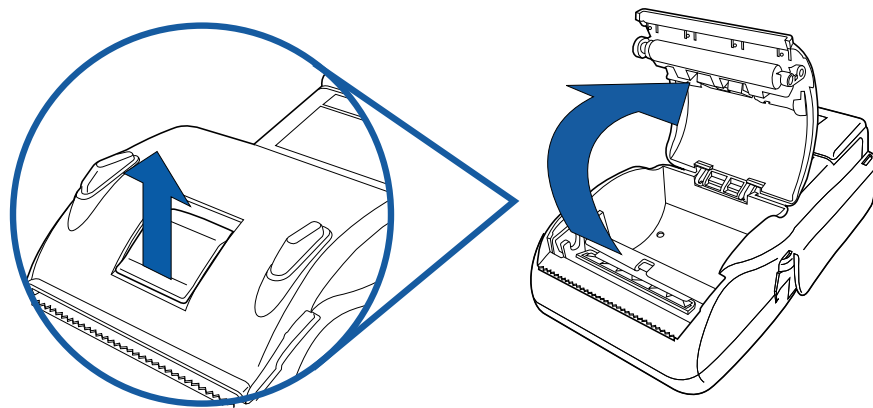

Figure 16 Unlocking the Printer Cover

- 4 Unscrew the latch to expose the MSAM compartment. (see Figure 17)

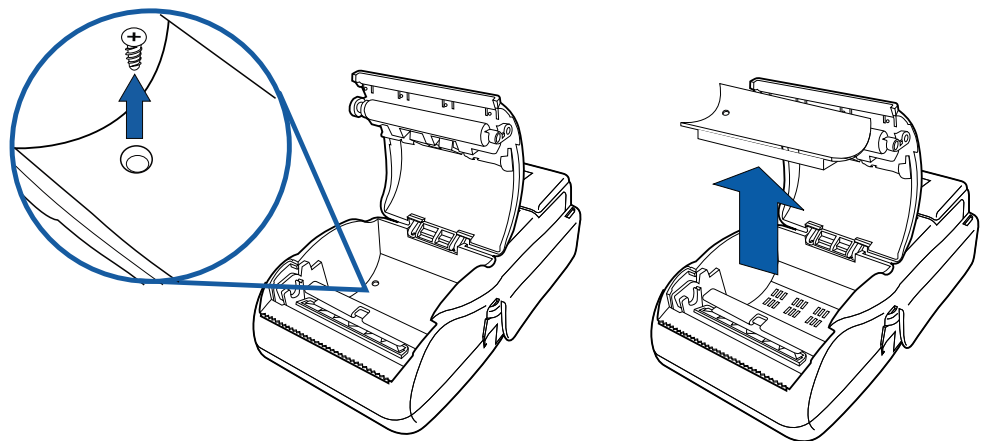

Figure 17 Exposing the MSAM Compartment

- 5 Remove any previously installed MSAM card by pushing the snap that keeps the SAM in place.

- 6 Install an MSAM card by placing the card facing the gold contacts down and carefully snap it on the tab until it is fully inserted.



NOTE Before inserting the MSAM card, position it as shown in [Figure 18](#), with the card's gold contacts facing the MSAM compartment. The cardholder connector base has a set of contacts and a notch on one corner to ensure that the MSAM card fits into the connector base and positioned correctly. The MSAM compartment door will not close properly if the MSAM card is installed incorrectly.

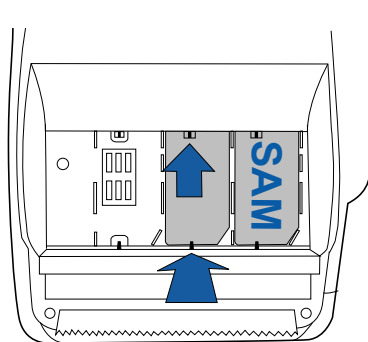

Figure 18 Installing MSAM Card

- 7 Screw back the MSAM compartment latch.

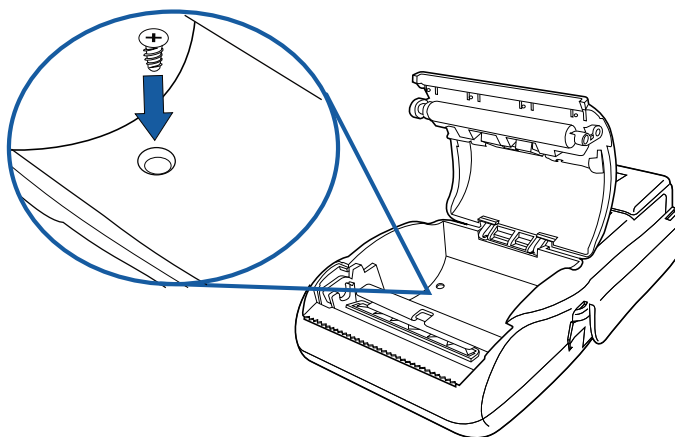

Figure 19 Closing the Printer Cover

- 8 Close the printer cover.

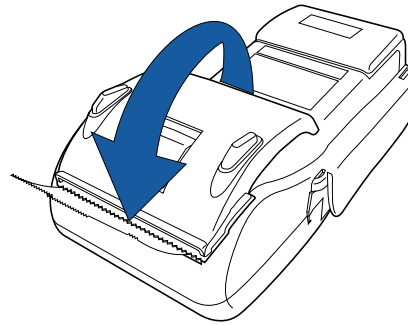

Figure 20 Closing the Printer Cover

Installing the SIM or R-UIM Card (GPRS and CDMA Models)

The VX 680 terminal for GPRS modems supports the installation of a GSM SIM (Subscriber Identity Module). While the VX 680 terminal for CDMA modems supports the installation of a R-UIM (Removable User Identity Module). Use the following procedure to install a SIM or R-UIM card.

To install or replace the card

- 1 Turn off the terminal.
- 2 Place the terminal upside down on a soft, clean surface to protect the lens from scratches.
- 3 Remove the battery.
- 4 Remove the battery to expose the SIM/R-UIM compartment, as shown in Figure 21.

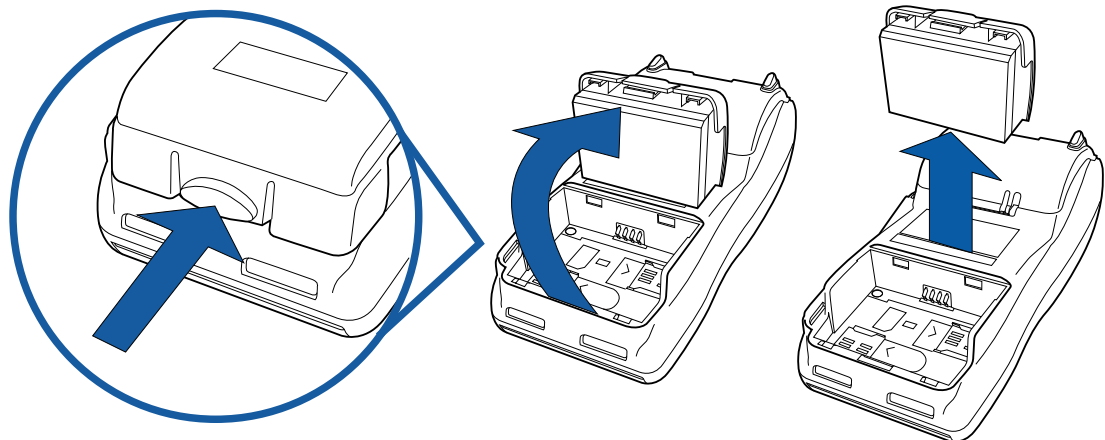

Figure 21 Removing the Smart Battery

- 5 Insert the SIM or the R-UIM card into the cardholder.

NOTE

There is only one SIM/R-UIM slot and one SD slot. Make sure you insert the SIM/R-UIM card into the SIM slot, as shown in [Figure 22](#).

Before inserting the SIM/R-UIM card, position it as shown in [Figure 22](#), with the card's gold contacts facing the compartment. The cardholder connector base has a set of contacts and a notch to ensure the SIM/R-UIM card is positioned correctly. The SIM/R-UIM card has a notch on one corner to ensure that it fits into the connector base in only one way.

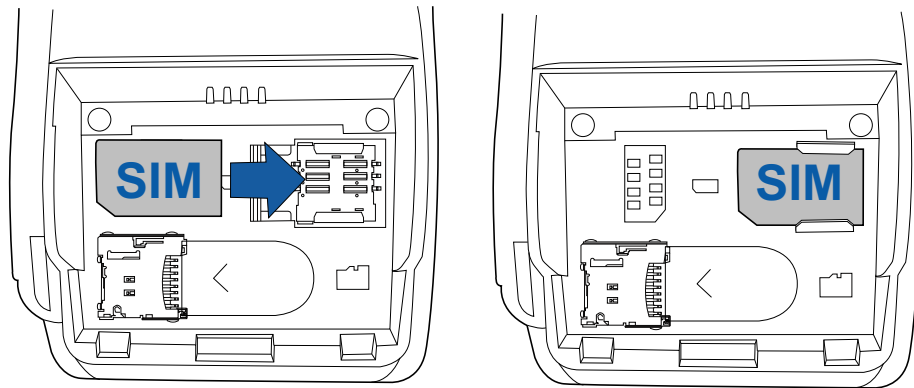

Figure 22 **Inserting the SIM or R-UIM Card**

- 6 Install the battery (see [Figure 24](#)).

Installing and Replacing SD Card

The VX 680 terminal supports the installation of an SD card on certain configurations. Use the following procedures to replace or install an SD card.

To install or replace the SD card

- 1 Turn off the terminal.
- 2 Place the terminal upside down on a soft, clean surface to protect the lens from scratches.
- 3 Remove the battery (see [Figure 21](#)).
- 4 After removing the battery, the SD card compartment is exposed, as shown in [Figure 23](#). The SD card holder is labeled SD.
- 5 Insert the SD Card into the cardholder.

NOTE



There is only one SIM/R-UIM slot and one SD slot. Make sure you insert the SD card into the SD slot, as shown in [Figure 23](#).

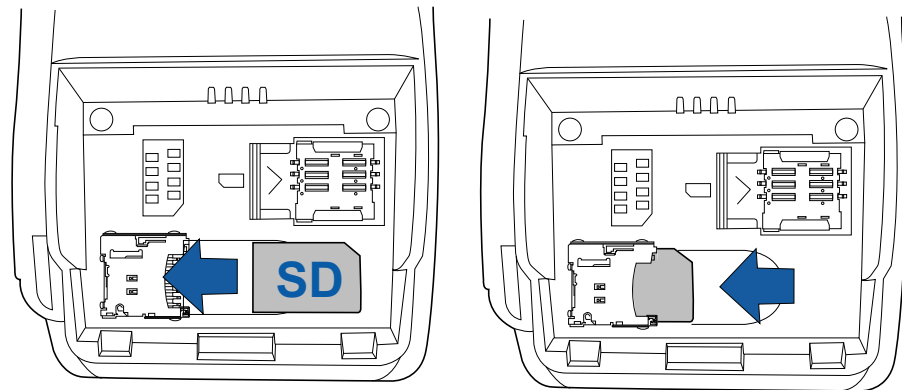

Figure 23 Installing SD Card

- 6 Install the battery (see [Figure 24](#)).

Using the Smart Battery

The VX 680 terminal uses a Li-ion *smart* battery (see [Accessories and Documentation](#) for ordering information). The internal logic of the smart battery prevents both overcharging and undercharging (a fault condition in which the battery level goes well below the minimum acceptable charge and the battery becomes unusable).

NOTE

The VX 680 terminal will operate on battery power or on power pack power. The smart battery charger in the terminal will be active whenever the power pack is connected.

Smart Battery Features

The following are features of the smart battery:

- Two Li-ion cells
- A fuel gauge module that:
 - monitors state of charge (voltage and percentage of capacity)
 - communicates with the terminal (charge parameters and status),
 - determines full charge capacity (on charge cycle and uninterrupted discharge cycle)
 - automatically shuts down when cell voltage is extremely low
- A safety circuit that:
 - prevents cell damage from overcharge, over-discharge, or overheating
 - activates when the battery is left in an unused terminal for extended periods

NOTE

- Li-ion batteries are not affected by shallow charging. Furthermore, when the terminal has no external power source or smart battery, the coin cell battery provides power to the security circuit.
 - Uninstalling the battery and unplugging the terminal power pack reduce the life of the coin cell battery, which does not recharge and must be replaced if drained.
 - Conserve battery power by turning the VX 680 terminal off when not in use. Keep the Li-ion battery inserted in the terminal and power up the terminal periodically to check the battery charge. Do not let the battery charge fall below 10% for extended periods of time as this may permanently diminish the battery capacity. Recharge the battery by attaching the power cable to the terminal and plugging the power pack into a wall outlet.
-

Battery Behavior (No Power Cable)

The terminal shifts to cabled power mode and starts up automatically when the VX 680 is connected to a non-battery power source, regardless of the battery charge state.

Manual Startup

Hold the green key down for about 4 seconds until the terminal displays the startup screen.

NOTE

The 4-second power-up delay prevents terminal startup if the green key is accidentally held down. The time required to hold the green key down to power up the terminal is configurable (for more information, see the *VX 680 Reference Guide – VPN DOC268-004-EN-B*).

The terminal lights up and the green LED indicator activates once the power is on.

NOTE

The VeriFone copyright screen starts and displays a unique copyright screen once the terminal loads an application. However, **DOWNLOAD NEEDED** appears on screen after the initial VeriFone copyright screen if there is no available application in the terminal.

Manual Shutdown

Hold the red key down for about 4 seconds until the terminal displays the shutdown verification screen. Keep holding the red key until the VX 680 terminal shuts down.

NOTE

- The 4-second shutdown delay that prevents terminal shutdown if the red key is accidentally held down. The time required to hold the red key down to shut down the terminal is configurable (for more information, see the *VX 680 Reference Guide – VPN DOC268-004-EN-B*).
 - The screen is blank and the green LED indicator is off when the terminal has no power.
-

Installing the Smart Battery

The VX 680 smart battery fits in a slot on the back of the VX 680 terminal, as shown in Figure 24. The locking tab clicks when the battery is in place. The slot is keyed, so that there is only one way to insert the battery.

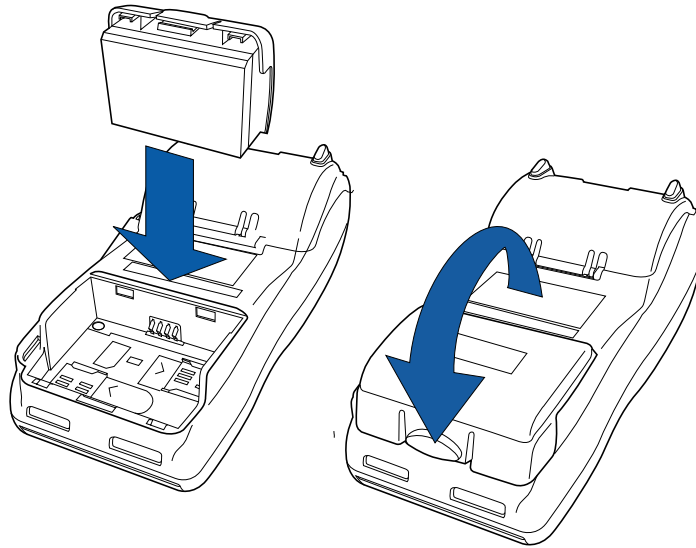

Figure 24 Installing the Smart Battery

Removing the Smart Battery

To remove the VX 680 smart battery, press the locking tab and pull the smart battery from its slot.

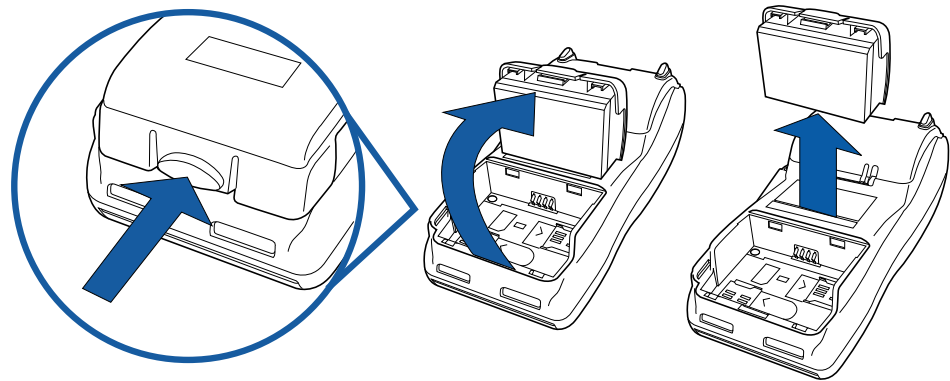

Figure 25 Detaching the Smart Battery from the VX 680 Terminal

Connecting the Terminal Power Pack

After installing the smart battery, connect the VX 680 terminal to the provided power source for initial charging.



CAUTION Using an incorrectly rated power supply may damage the terminal or cause it not to work as specified. Before troubleshooting, ensure that the power supply being used to power the terminal matches the requirements specified on the bottom of the terminal. (See [Specifications](#) for detailed power supply specifications.) Obtain the appropriately rated power supply before continuing with troubleshooting.



WARNING Do not plug the power pack into an outdoor outlet or operate the terminal outdoors.

During a transaction, disconnecting the power by removing the battery or unplugging the terminal from a wall power while at very low battery charge may cause transaction data files not yet stored in the terminal memory to be lost.

The VX 680 unit comes with a universal input power pack capable of operating from voltages of 100V to 240V AC.

To Connect the Terminal Power Pack

- 1 Insert the round barrel connector into the power port in the connector, as shown in [Figure 26](#).

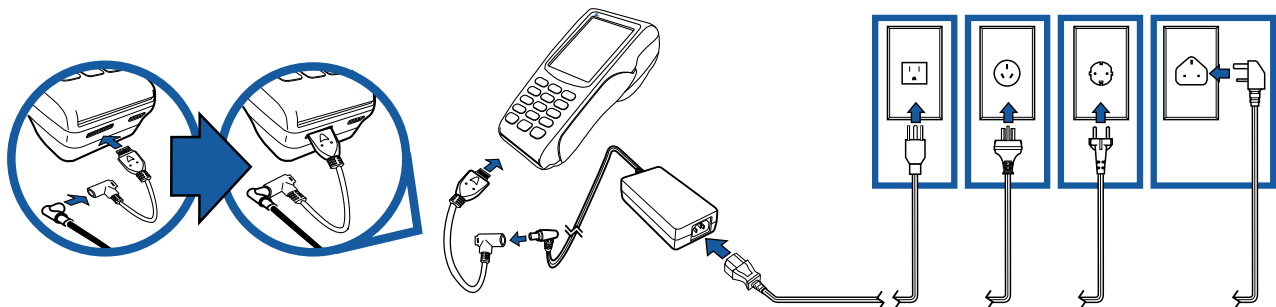

Figure 26 VX 680 Power Pack Connection

- 2 Insert the AC power cable into the power pack.
- 3 Plug the AC power cable into a wall outlet or powered surge protector.

NOTE



To protect against possible damage caused by lightning strikes and electrical surges, consider installing a power surge protector.

The light indicators on the VX 680 appear when the terminal receives power.

Once it loads the application, the terminal starts the initial VeriFone copyright screen and displays a unique copyright screen. If there is no available application in the terminal, **DOWNLOAD NEEDED** appears on screen after the initial VeriFone copyright screen.

Charging the Smart Battery

After unpacking your VX 680 terminal, install the battery and connect the power pack to the unit for 6 hours or until fully charged.

NOTE

The terminal charges the VX 680 smart battery when the terminal is in the Base Station. For more information, see [Mounting the Terminal Onto the Base Station](#).

The smart battery has a safety circuit to protect the Li-ion cells from overcharging and over-discharging. If the battery is over-discharged, the safety circuit shuts down the battery. The battery must then be recharged to restore operation.

NOTE

The VX 680 terminal automatically shuts off when the smart battery reaches the *critically low* charge state. If this occurs, the smart battery must be recharged for a minimum of 1/2 hour before it can power the terminal. *It may take several recharge attempts to reset the safety circuit* when charging a smart battery that has been discharged below this critical state.

Battery Life

Charging and discharging the VX 680 smart battery hundreds of times will wear out the battery. Significantly reduced operating times indicate the need for battery replacement (see [Accessories and Documentation](#) for ordering information).

WARNING

Do not dispose of batteries in a fire. Li-ion batteries must be recycled or disposed of properly. Do not dispose of Li-ion batteries in municipal waste sites.



Using the Base Station

The primary purpose of the Base Station is to charge the terminal battery and provide a docking station for the terminal after being used in pay-at-table environments. The Base Station can be positioned on a countertop or mounted to the wall.

There are three types of Base Stations: the standard model, the full-featured model and the Bluetooth® Access Point Charging Base.

Standard Base Station

The standard Base Station can charge the VX 680 terminal. However, it does not have any external ports and has a single LED to indicate power status.

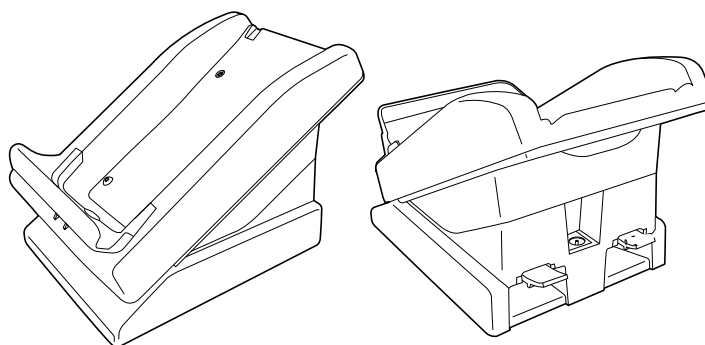

Figure 27 The VX 680 Standard Base Station

Full-Featured Base Station

The full-featured Base Station can charge the VX 680 terminal while charging an extra battery pack. In addition, it has two USB ports for external dongles, together with one LED for power indication and another LED for the charger status.

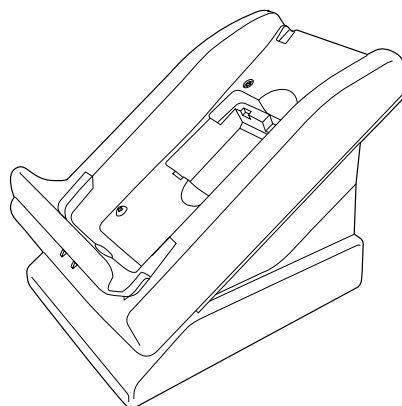

Figure 28 The VX 680 Full-Featured Base Station

For more information on charging the spare battery on the full-featured Base Station and connecting external dongles to the USB ports, see [Charging the Spare Battery on the Base Station](#) and [Attaching the USB Dongles to the Base Station](#).

Bluetooth® Access Point Charging Base

The Bluetooth® Access Point Charging Base allows the VX 680 WiFi and Bluetooth®-enabled terminal to connect wirelessly to the network. It has three LED indicators: power indicator, bluetooth traffic and modem traffic.

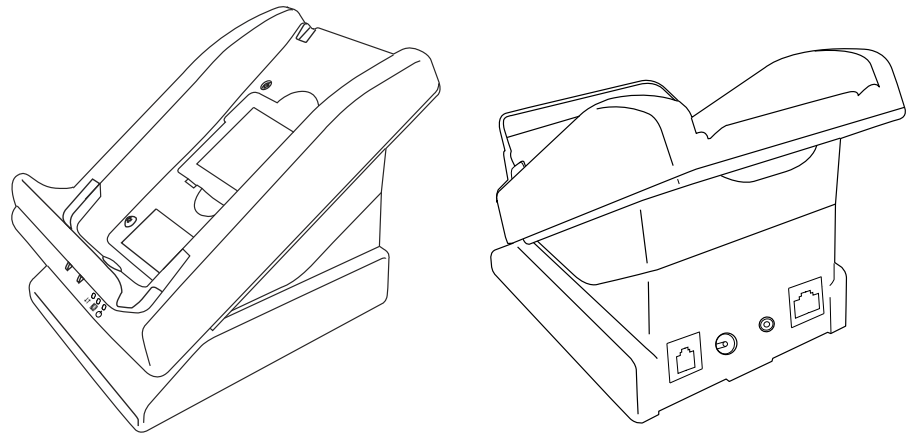

Figure 29 The VX 680 Bluetooth Access Point Charging Base Station

Powering Up the Base Station

Use the procedure in this section to connect the VX 680 Base Stations to a power source.

To power up the base station

- 1 Insert the round barrel connector of the power pack into the power port at the back of the Base Station. For Bluetooth® Access Point Charging Base Station, see [Power Connection to the Bluetooth® AP Charging Base Station](#).

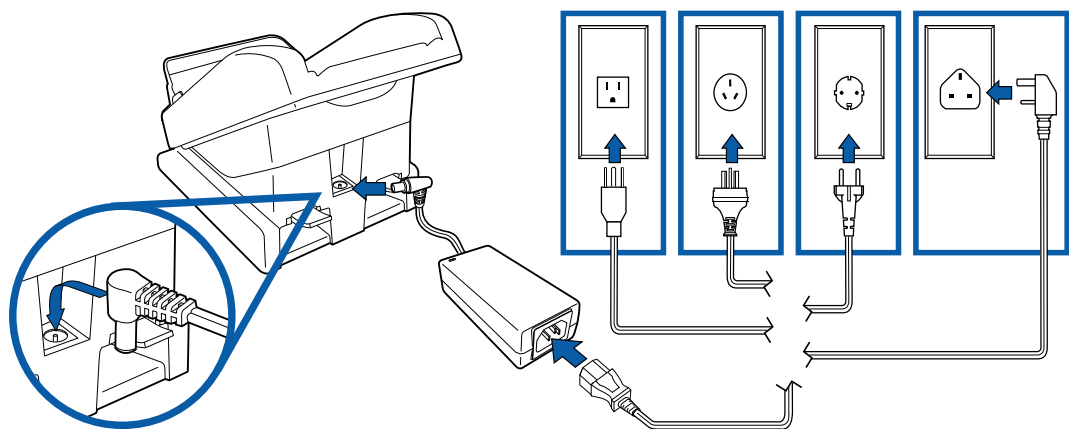

Figure 30 Connecting the Base Station to a Power Source

- 2 Insert the AC power cable into the power pack.
- 3 Plug the AC power cable into a wall outlet or power surge protector.
- 4 Confirm that the Base Station is powered up as indicated by the solid green LED.

Mounting the Terminal Onto the Base Station

The VX 680 terminal can be placed on the Base Station when not in use for continuous charging of its battery. External peripherals can also be attached to the terminal via USB dongles while it is on the Base Station (see [Attaching the USB Dongles to the Base Station](#)).

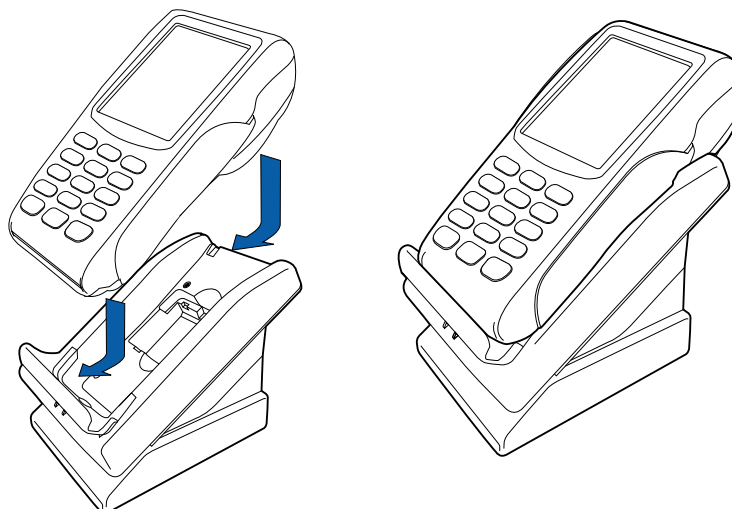

Figure 31 Placing the VX 680 terminal onto the Base Station

**NOTE**

The full-featured Base Station can also charge a spare battery while it charges the battery attached to the terminal (see [Charging the Spare Battery on the Base Station](#)).

To protect against possible damage caused by lightning strikes and electrical surges, consider installing a power surge protector.

**WARNING**

Do not plug the power pack into an outdoor outlet or operate the terminal outdoors.

Disconnecting the power during a transaction may cause transaction data files not yet stored in terminal memory to be lost.

Attaching the USB Dongles to the Base Station

With the VX 680 mounted on the Base Station, use the USB dongles to connect to external peripherals. Only one Modem Dongle and one Serial Dongle can be connected to the Base Station. A second Modem Dongle or a second Serial Dongle will be ignored by the terminal.

NOTE



The full-featured Base Station has USB ports for two external dongles. The standard Base Station does not have USB ports.

- 1 Insert the USB dongle into the USB port located at the back of the Base Station.

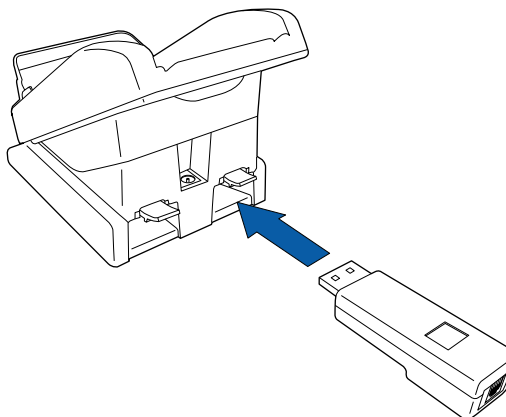

Figure 32 Inserting External Dongle Into USB Port

- 2 After inserting the external dongle into the USB port, place the VX 680 terminal onto the Base Station (see [Powering Up the Base Station](#)).
- 3 Connect the peripheral to the external dongle.

Charging the Spare Battery on the Base Station

The full-featured Base Station can charge the VX 680 terminal while charging an extra battery pack.

- 1 Connect the Base Station to a power source (see [Powering Up the Base Station](#))

- 2 Place the spare battery pack onto the Base Station.

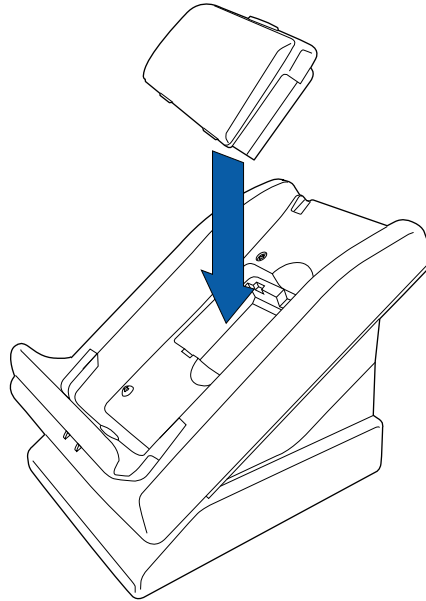

Figure 33 Charging a Spare Battery Pack Using the Base Station

- 3 Place the VX 680 terminal onto the Base Station to charge both the spare and installed battery packs at the same time.

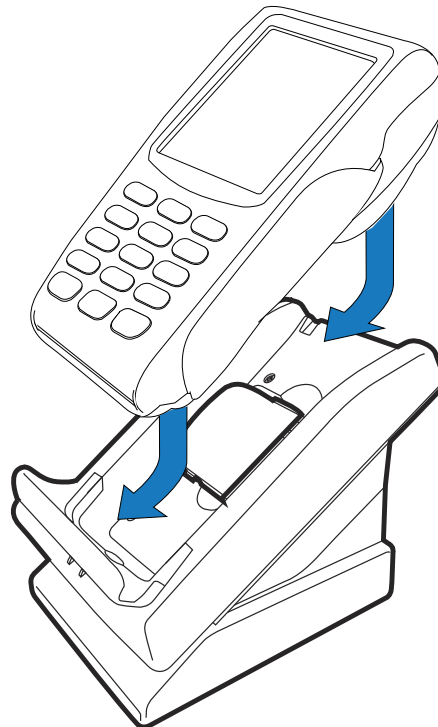

Figure 34 Charging the Spare and Installed Battery Simultaneously

Conducting Wireless Transactions

To conduct a wireless transaction:

- Ensure the terminal is in an optimal position for transmitting.
- Follow the on-screen instructions provided with your application.

Conducting Smart Card Transactions

The smart card transaction procedure may vary from one application to another. Verify the procedure with your application provider before performing a smart card transaction.

To Conduct a Smart Card Transaction

- 1 Position a smart card with the contacts facing upward (see [Figure 35](#)).
- 2 Insert the smart card into the smart card reader slot in a smooth, continuous motion until it seats firmly.
- 3 Remove the card only when the application indicates the transaction is complete.

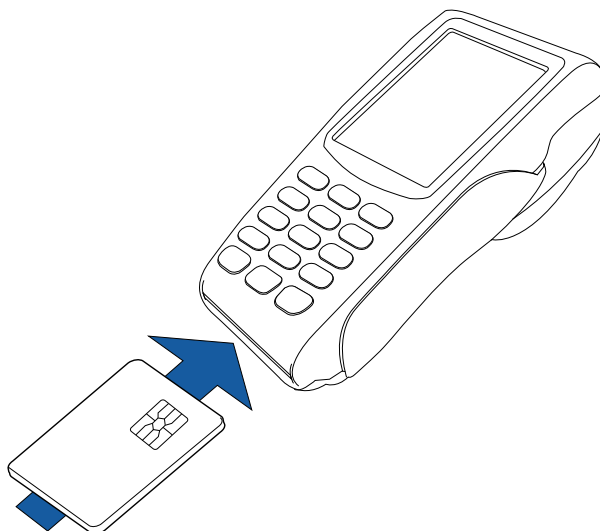

Figure 35 Inserting a Smart Card



CAUTION Do not remove the smart card in the card reader until the transaction is complete. Premature card removal will invalidate the transaction.

Conducting Bluetooth® Transactions

To conduct a Bluetooth® transaction:

- Ensure the terminal is paired with the Bluetooth® AP Charging Base Station not more than 100 meters away.
- Follow the on-screen instructions provided with your application.

Using the Magnetic Card Reader

The VX 680 terminal supports credit/debit card transactions.

To Conduct a Credit or Debit Card Transaction

- 1 Position a magnetic card with the stripe in the card reader and facing inward, toward the keypad.
- 2 To ensure a proper read of the magnetic swipe card, the user should insert the magnetic card from the top of the unit, as shown in [Figure 36](#).
- 3 Swipe the card through the magnetic card reader.

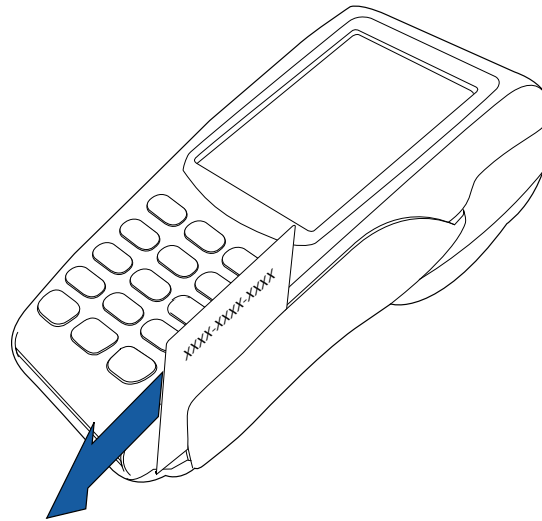

Figure 36 Using the Magnetic Card Reader

Using the Stylus

The VX 680 terminal has a touchscreen capability which allows the use of a stylus on a transaction.

To Use the Stylus

- 1 Remove the stylus from the top portion of the terminal, as shown in [Figure 37](#).

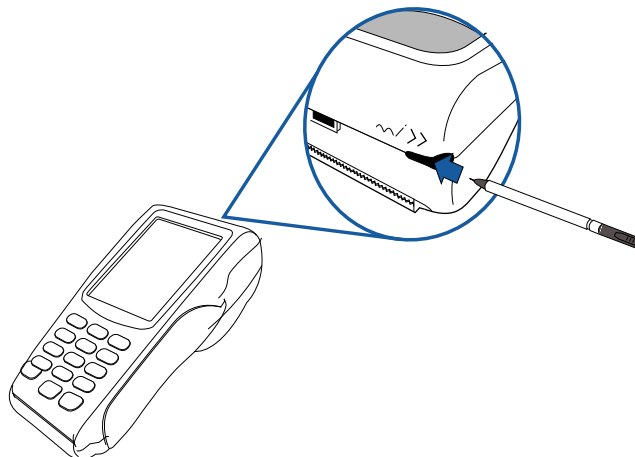

Figure 37 Removing the Stylus

- 2 The stylus can be extended. Use this for touchscreen transactions as shown in Figure 38.

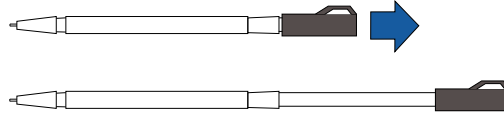

Figure 38 Extending the Stylus

- 3 Loop a piece of cable or string (not supplied) through the stylus hole and the base of the printer cover to secure the stylus.

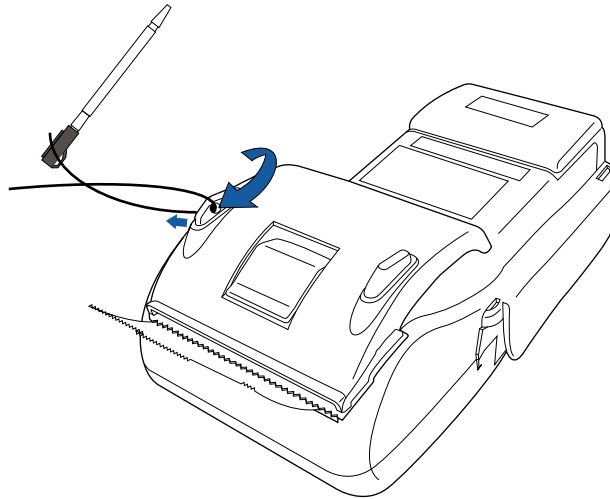

Figure 39 Securing the Stylus to the Terminal

Specifications

This chapter discusses power requirements, dimensions, and other specifications of the VX 680 terminal.

Power 12V DC 2.0 A

DC Power Pack UL, ITE listed, LPS power supply:

- a Input rated: 100-240V AC, 50/60 Hz
- b Output rated: 12V DC 2.0 A

Barrel connector polarity:



- Temperature**
- Operating temperature: 0° to 50° C (32° to 122° F)
 - Relative humidity: 5% to 90%; non-condensing

- External Dimensions**
- Length: 171.5 mm (6.8 in)
 - Width: 86 mm (3.4 in)
 - Depth: 63 mm (2.5 in)

SPECIFICATIONS*External Dimensions*

Maintenance

The VX 680 terminal and Base Stations have no user-serviceable parts.

Cleaning the Terminal

To clean the terminal and Base Station, use a clean cloth slightly dampened with water and a drop or two of mild soap. For stubborn stains, use alcohol or an alcohol-based cleaner.

CAUTION



Never use thinner, trichloroethylene, or ketone-based solvents – they may cause deterioration of plastic or rubber parts.

Do not spray cleaners or other solutions directly onto the keypad or terminal display.

Terminal Contacts

Gently swab the contacts with alcohol or contact cleaner to remove the dirt. It is important that the exposed contacts of the VX 680 battery stay clean and unbent.

CAUTION



Avoid touching the contacts of the VX 680 battery and the recessed area on the terminal. Finger oils tarnish contacts, causing bad connections. When operating on battery power and experiencing a high occurrence of bad or incomplete data transfers, clean the contacts.

Smart Card Reader

Do not attempt to clean the smart card reader. Doing so may void any warranty. For smart card reader service, contact your VeriFone distributor or service provider.

VeriFone Service and Support

For VX 680 terminal problems, contact your local VeriFone representative or service provider.

For VX 680 product service and repair information:

- USA – VeriFone Service and Support Group, 1-800-VeriFone (837-4366), Monday - Friday, 8 A.M. - 8 P.M., Eastern time
- International – Contact your VeriFone representative

Returning a Terminal or Smart Battery for Service

Before returning a VX 680 terminal, smart battery, or Base Station to VeriFone, you must obtain an MRA number. The following procedure describes how to return one or more VX 680 terminals, smart batteries, or Base Stations for repair or replacement (U.S. customers only).

NOTE

Customers outside the United States are advised to contact their local VeriFone representative for assistance regarding service, return, or replacement of terminals or batteries.

To Return a Terminal for Service

- 1 Get the following information from the printed labels on the bottom of *each* VX 680 terminal, smart battery, or sled module to be returned:
 - Product ID, including the model and part number. For example, “VX 680” and “M268-XXX-XX-XXX-2.”
 - Serial number (S/N nnn-xxx-xxx)
- 2 Obtain the MRA number(s) by completing one of the following:
 - a Call VeriFone toll-free within the United States at 1-800-VeriFone and follow the automated menu options.
 - Select the MRA option from the automated message. The MRA department is open Monday to Friday, 8 A.M.–8 P.M., Eastern Time.
 - Give the MRA representative the information you gathered in Step 1. If the list of serial numbers is long, you can fax the list, along with the information gathered in Step 1, to the MRA department at 727-953-4172 (U.S.).
 - b Address a fax to “VeriFone MRA Dept.” with the model and part number(s)
 - Include a telephone number where you can be reached and your fax number.

- c Complete the Inquiry Contact Form at http://www.verifone.com/aboutus/contact/contact_form.cfm.
 - Address the Subject box with to “VeriFone MRA Dept.”
 - Reference the model and part number in the Note box.



NOTE One MRA number must be issued for each VX 680 terminal you return to VeriFone, even if you are returning several of the same model.

- 3 Describe the problem(s).
- 4 Provide the shipping address where the repaired or replacement unit must be returned.
- 5 Keep a record of the following items:
 - Assigned MRA number(s).
 - VeriFone serial number assigned to the VX 680 terminal, smart battery, or base station you are returning for service or repair (terminal serial numbers are located on the bottom of the unit).
 - Shipping documentation, such as air bill numbers used to trace the shipment.
 - Model(s) returned (model numbers are located on the VeriFone label on the bottom of the VX 680 terminal).

Accessories and Documentation

VeriFone produces the following accessories and documentation for the VX 680 terminal. When ordering, please refer to the part number in the left column.

- VeriFone online store at www.store.verifone.com
- USA – VeriFone Customer Development Center, 800-VeriFone (837-4366), Monday - Friday, 7 A.M. - 8 P.M., Eastern time
- International – Contact your VeriFone representative

Power Pack

Contact your local VeriFone distributor to determine which power pack or power cable fits your needs.

VPN PWR268-001-01-B	DC Power Pack (Universal)
VPN CBL000-008-03-A	AC Power Cable (US)

Printer Paper

VPN PPR 268-001-01-A	38 mm (1.49 in) diameter, 57 mm (2.24 in) wide
----------------------	--

VeriFone Cleaning Kit

VPN 02746-01	Cleaning Kit
--------------	--------------

Spare Battery

VPN BPK268-001-01-A	VX 680 Spare Battery
---------------------	----------------------

USB Host Cable

VPN CBL268-003-01-A	VX 680 USB Host Cable
---------------------	-----------------------

Modem Dongle

VPN M267-D80-00	VX 680 Modem Dongle
-----------------	---------------------

Serial Dongle

VPN M267-D08-00	VX 680 Serial Dongle
-----------------	----------------------

Telephone Line Cable

VPN CBL000-001-01-A	2.1-meter (7-foot) telephone line cable, black, with modular RJ11-type connectors)
---------------------	--

Documentation

VPN DOC268-001-EN-A	VX 680 Certifications and Regulations Sheet
VPN DOC268-002-EN-A	VX 680 Quick Installation Guide
VPN DOC268-004-EN-B	VX 680 Reference Guide
VPN DOC268-005-EN-A	VX 680 Standard Base Quick Installation Guide
VPN DOC268-006-EN-A	VX 680 Full-Featured Base and Dongle Quick Installation Guide
VPN DOC268-012-EN-A	VX 680 CDMA Certifications and Regulations Sheet
VPN DOC00301	Verix eVo Volume I: Operating System Programmers Manual
VPN DOC00302	Verix eVo Volume II: Operating System and Communication Programmers Manual
VPN DOC00303	Verix eVo Volume III: Operating System Programming Tools Reference Manual

Troubleshooting Guidelines

The troubleshooting guidelines provided in the following section are included to help you install and configure your VX 680 terminal successfully. Typical examples of malfunction you may encounter while operating your VX 680 terminal and steps you can take to resolve them are listed in this chapter.

If the problem persists even after performing the outlined guidelines or if the problem is not described below, contact your local VeriFone representative for assistance.



NOTE The VX 680 terminal comes equipped with tamper-evident labels. The VX 680 unit contains no user serviceable parts. Do not, under any circumstance, attempt to disassemble the terminal. Perform only those adjustments or repairs specified in this guide. For all other services, contact your local VeriFone service provider. Service conducted by parties other than authorized VeriFone representatives may void any warranty.



CAUTION Use only a VeriFone-supplied power pack. Using an incorrectly rated power supply may damage the terminal or cause it not to work as specified. Before troubleshooting, ensure that the power supply being used to power the terminal matches the requirements specified on the bottom of the terminal. (See [Specifications](#), for detailed power supply specifications.) Obtain the appropriately rated power supply before continuing with troubleshooting.

Terminal Does Not Start

- Ensure that the smart battery charge state is not below the critically low level.
- Recharge or replace the smart battery.
- Ensure that you pressed the green ENTER/ON key for approximately 4 seconds, until the unit lights up.

Terminal Display Does Not Show Correct/Readable Info

- Recharge or replace the battery.
- Connect the VX 680 terminal into a known-good power supply (if you have one) to see if this clears the problem.
- If the problem persists, contact your local VeriFone representative for assistance.

Smart Battery Does Not Charge

The VX 680 smart battery must initially receive a full charge to ensure proper operation.

NOTE



- Allow the VX 680 terminal to remain connected to the power pack for 6 hours to ensure the battery receives a full charge.
- Li-ion batteries are not affected by shallow charging. Furthermore, when the terminal has no external power source or battery the coin cell battery provides power to the security circuit.
- Uninstalling the battery and unplugging the terminal power pack reduce the life of the coin cell battery, which does not recharge and must be replaced if drained.
- Conserve battery power by turning the VX 680 terminal off when not in use. If the terminal will not be used for an extended period of time, keep the Li-ion battery inserted in the terminal, and power up the terminal periodically to check the battery charge. Do not let the battery charge fall below 10% for extended periods of time as this may permanently diminish the battery capacity. Recharge the battery by attaching the power cable to the terminal and plugging the power pack into a wall outlet.
- The VX 680 terminal automatically shuts off when the smart battery reaches the *critically low* charge state. If this occurs, the smart battery must recharge a minimum of 1/2 hour before it can power the terminal. *It may take several recharge attempts to reset the safety circuit* when charging a smart battery that has been discharged below this critical state.

Spare Battery in Base Station Does Not Charge

When the spare battery is installed in the base for charging, the Base LED will flash amber if the battery is charging, or stay solid green if the battery is fully charged. If the battery is not charged and the LED does not flash amber, check the contacts on the battery and in the terminal base to make sure they are clean. Also, try charging a known good battery to see if the problem is with the base or with the battery. If the problem persists, contact your local VeriFone representative.

Blank Display

When the VX 680 terminal display screen does not show correct or clearly readable information:

- The battery pack may not be connected properly. Remove and reinstall the battery pack.
- Check terminal power connection.
- Remove and reapply power to the terminal.
- If the problem persists, contact your local VeriFone service provider.

Terminal Does Not Dial Out

If the terminal does not dial out:

- Check the telephone line connections.
- Check that the telephone line is working by plugging it into a working telephone and listening for a dial tone.
- Replace the telephone cable that connects the terminal with a cable you know is working correctly.
- If the problem persists, contact your local VeriFone service provider.

Printer Does Not Print

If the printer does not work properly:

- Make sure the battery is properly installed in the terminal. The printer will not print if there is no battery in the terminal.
- Check battery status or terminal power connection. The printer will not print if there is an insufficient charge remaining in the battery to complete the print operation.
- Check if the printer is out of paper (slow red blinking light) and that the roll is properly installed. Open the paper roll cover and install a new roll of printer paper or ensure that the roll is feeding correctly. A solid red indicator light indicates a printer error.
- Verify that the printer door is properly latched.
- If the problem persists, contact your VeriFone distributor or service provider.

Printer Paper Jam

If paper jams inside the printer:

- Press the button at the bottom of the terminal to unlatch the paper roll cover, then open the cover.
- Remove the damaged paper from the paper roll and clear the feed mechanism.
- Install a roll of printer paper, as described in [Installing the Paper Roll](#).
- If the problem persists, it may be due to poor paper quality. Install a new roll of higher-quality paper.



Poor-quality paper may jam the printer. To order high-quality VeriFone paper, refer to [Accessories and Documentation](#).

Keypad Does Not Respond

If the keypad does not respond properly:

- Check the terminal display. If it displays the wrong character or nothing at all when you press a key, follow the steps outlined in [Transactions Fail to Process](#).
- If pressing a function key does not perform the expected action, refer to the user documentation for that application to ensure you are entering data correctly.
- If the problem persists, contact your local VeriFone representative.

Transactions Fail to Process

There are several reasons why the terminal may not be processing transactions. Use the following steps to troubleshoot failures.

Check the Magnetic Card Reader

- Perform a test transaction using one or more different magnetic stripe cards to ensure the problem is not a defective card.
- Ensure that you are swiping cards properly. With the VX 680 card reader, the black magnetic stripe on the card should face down and inward, toward the keypad and must be inserted from the top of the terminal (see [Figure 36](#)).
- Process a transaction manually, using the keypad instead of the card reader. If the manual transaction works, the problem may be a defective card reader.
- Contact your VeriFone distributor or service provider.
- If the manual transaction does not work, proceed to [Check the Telephone Line](#).

Check the Smart Card Reader

- Perform a test transaction using several different smart cards to ensure the problem is not a defective card.
- Ensure that the card is inserted correctly and that the card is not removed prematurely.
- Ensure the MSAM cards are properly inserted in the cardholders and that the cardholders are properly secured (see [Installing and Replacing MSAM Cards](#)).
- Contact your VeriFone distributor or service provider.
- If the manual transaction does not process, proceed to [Check the Telephone Line](#).

Check the Telephone Line

- Disconnect the telephone line from the VX 680 terminal and connect it to a working telephone to check for a dial tone. If there is no dial tone, replace the telephone cable.
- If the problem appears to be with the telephone line, check with the party you are trying to call to see if their system is operational. If they are not experiencing difficulties with their line, contact the telephone company and have your line checked.
- If the telephone line works, contact your local VeriFone representative for assistance.



A

- accessories **50**
 - documentation **51**
 - ordering **51**
 - power packs **50**
 - telephone line cord **51**
 - thermal printer paper **50**
 - VeriFone cleaning kit **50**

B

- Base Station **37**
- batteries
 - extending the battery life **36**
 - See also smart battery
- battery mode
 - VX 680 **33**

C

- cleaning kit **50**
- cleaning kits
 - ordering **50**
- connection ports **18**
- contact VeriFone **49**

D

- dial out problems
 - troubleshooting **55**
- displays
 - troubleshooting **53, 55**
- documentation **50**
 - acronym definitions **8**
 - conventions **8**
 - ordering **51**

E

- electrical considerations **16, 29**
- electrostatic discharges **29**
 - prevention **29**
- environmental factors **15**

F

- full-featured Base Station **37**

H

- HDMI **8, 22**

I

- installation **11**
 - connecting the terminal power pack **35**
 - connecting the terminal to a telephone line **22**
 - MSAM cardholder **29**
 - MSAM card **29**
 - terminal location **15**
 - unpacking the shipping carton **16**

K

- keypads
 - troubleshooting **56**

M

- maintenance
 - cleaning the terminal **47**
 - cleaning the terminal contacts **47**
 - returning a battery for repair or replacement **49**
 - returning a terminal for repair or replacement **49**
- MSAM cardholder **29**
- MSAM card **29**

P

- paper jams
 - troubleshooting **55**
- paper rolls
 - for thermal printers **27, 56**
 - installation **27**
- power adapter cables **19**
- power packs
 - AC version **50**
 - connecting **35**
 - DC version **50**
 - ordering **50**

- printer paper
 - ordering **50**
- printers
 - troubleshooting **55**

R

- RS-232 UART **20**
- R-UIM
 - for CDMA models **31**

S

- service
 - returning a battery for repair or replacement **49**
 - returning a terminal for repair or replacement **49**
- SIM cards
 - for GSM models **31**
- smart battery **36**
 - battery life **36**
 - charging **36**
 - conserving power **32**
 - disposal **36**
 - features **32**
 - installation **34**
 - recharging **36**
 - removal **34**
 - troubleshooting **54**
- spare batteries
 - charging on the Full-Featured Base Station **40**
 - ordering **50**
- specifications
 - DC power pack **45**
 - power **45**
 - temperature **45**
- standard Base Station **37**

T

- technical support
 - contacting VeriFone **49**
 - returning a battery for repair or replacement **49**
 - returning a terminal for repair or replacement **49**
- telephone line connections **22**
- telephone line cords
 - ordering **51**
- terminal features
 - general **17**

- terminals
 - accessories **50**
 - benefits **12**
 - cleaning **47**
 - documentation **50**
 - electrical considerations **16**
 - environmental factors **15**
 - features **17**
 - repair **49**
 - replacement **49**
 - service and support **49**
 - troubleshooting **53, 55**
- thermal paper
 - ordering **50**
- thermal printer paper
 - storage **27**
- thermal printers
 - about the thermal printer paper **27, 56**
 - paper jams **55**
 - troubleshooting **55**
- transactions
 - smart cards **41**
 - wireless **41**
- troubleshooting
 - batteries **54**
 - displays **53, 55**
 - guidelines **53**
 - keypads **56**
 - printers **55**
 - terminal transactions **56**
 - terminals **53, 55**

U

- USB dongles
 - modem **20**
 - serial **20**
- USB host cable **19, 51**
- USB modem dongles
 - ordering **51**
- USB serial dongles **20**
 - ordering **51**

V

VX 680

starting on battery power **33**

VX 680 startup

battery mode **33****W**wireless transactions **41**



VeriFone, Inc.
2099 Gateway Place, Suite 600
San Jose, CA, 95110 USA
1-800-VERIFONE
www.verifone.com

DRAFT
REVISION C.4



VX 680

Installation Guide

