

V^x680

Installation Guide

VERIFONE
CONFIDENTIAL
DRAFT
REVISION A.3



V*680 Installation Guide
© 2009 VeriFone, Inc.

All rights reserved. No part of the contents of this document may be reproduced or transmitted in any form without the written permission of VeriFone, Inc.

The information contained in this document is subject to change without notice. Although VeriFone has attempted to ensure the accuracy of the contents of this document, this document may include errors or omissions. The examples and sample programs are for illustration only and may not be suited for your purpose. You should verify the applicability of any example or sample program before placing the software into productive use. This document, including without limitation the examples and software programs, is supplied "As-Is."

VeriFone, the VeriFone logo, Omni, VeriCentre, Verix, and ZonTalk are registered trademarks of VeriFone. Other brand names or trademarks associated with VeriFone's products and services are trademarks of VeriFone, Inc.

All other brand names and trademarks appearing in this manual are the property of their respective holders.

Comments? Please e-mail all comments on this document to your local VeriFone Support Team.

WARNING



Do not dispose of the Vx680 Li-ion smart battery in a fire. Li-ion batteries must be recycled or disposed of properly. Do not dispose of Li-ion batteries in municipal waste sites.



VERIFONE
CONFIDENTIAL
DRAFT
REVISION A.3

VeriFone, Inc.
2099 Gateway Place, Suite 600
San Jose, CA, 95110 USA
1-800-VERIFONE

www.verifone.com



CONTENTS

	PREFACE	7
	Audience	7
	Organization	7
	Related Documentation	7
	Conventions and Acronyms	8
	Document Conventions	8
	Acronym Definitions	8
CHAPTER 1		
Terminal Overview	Features and Benefits	12
	Exceptional Ease of Use	12
	Performance and Durability	13
	Security	13
	Contactless Capability	13
	Communication Technology	13
CHAPTER 2		
Terminal Setup	Selecting Terminal Location	15
	Environmental Factors	15
	Electrical Considerations	16
	Considerations for Bluetooth® Comm Base Station	16
	Unpacking the Shipping Carton	16
	Examining Terminal Features	17
	Front Panel	17
	Examining Connection Ports	18
	Power Adapter Cable	19
	USB Host Cable	19
	Multiport Adapter	20
	USB Modem Dongle	20
	USB Serial Dongle (RS232 UART)	20
	Establishing Telephone Line Connections	22
	Installing the Paper Roll	27
	Installing/Replacing MSAM Cards	29
	Installing/Replacing SIM Card (GSM/GPRS Models Only)	31
	Using the Smart Battery	32
	Smart Battery Features	32
	Battery Behavior (No Power Cable)	33
	Manual Startup	33
	Manual Shutdown	33

	Installing the Smart Battery	34
	Removal	34
	Connecting the Terminal Power Pack	35
	Charging the Smart Battery	36
	Battery Life	36
	Using the Base Station	37
	Standard Base Station	37
	Full-Feature Base Station	37
	Powering Up the Base Station	38
	Placing the Terminal Onto the Base Station	39
	Attaching the USB Dongles to the Base Station	39
	Charging the Spare Battery on the Base Station	40
	Conducting Wireless Transactions	41
	Conducting Smart Card Transactions	41
	Conducting Bluetooth® Transactions	42
	Using the Magnetic Card Reader	42
CHAPTER 3		
Specifications	Power	45
	DC Power Pack	45
	Temperature	45
	External Dimensions	45
CHAPTER 4		
Maintenance	Cleaning the Terminal	47
	Terminal Contacts	47
	Smart Card Reader	47
CHAPTER 5		
VeriFone Service and Support	Returning a Terminal or Smart Battery for Service	49
	Accessories and Documentation	50
	Power Pack	50
	Thermal Printer Paper	50
	VeriFone Cleaning Kit	50
	Spare Battery	50
	USB Host Cable	51
	Modem Dongle	51
	Serial Dongle	51
	Telephone Line Cable	51
	Documentation	51

CHAPTER 6
Troubleshooting
Guidelines

Terminal Does Not Start	53
Terminal Display Does not Show Correct/Readable Info	53
Terminal is Unable to Go Online and Displays Connection Failure (for Bluetooth® variant)	54
Smart Battery Will Not Charge	54
Spare Battery in Base Station Will Not Charge	54
Blank Display	55
Terminal Does Not Dial Out	55
Printer Does Not Print	55
Printer Paper Jam	55
Keypad Does Not Respond	56
Transactions Fail To Process	56
INDEX	59

VERIFONE
CONFIDENTIAL
DRAFT
REVISION A.3



VERIFONE
CONFIDENTIAL
DRAFT
REVISION A.3





This guide is your primary source of information for setting up and installing the Vx680 terminal.

Audience

This guide is useful for anyone installing and configuring a Vx680 terminal. Basic descriptions of the terminal features are also provided.

Organization

This guide is organized as follows:

[Chapter 1, Terminal Overview](#). Provides an overview of the Vx680 terminal.

[Chapter 2, Terminal Setup](#). Explains how to set up and install the Vx680 terminal. It tells you how to select a location, establish power and telephone line connections, and how to configure optional peripheral devices.

[Chapter 3, Specifications](#). Discusses power requirements and dimensions of the Vx680 terminal.

[Chapter 4, Maintenance](#). Explains how to maintain your Vx680 terminal.

[Chapter 5, VeriFone Service and Support](#). Provides information on contacting your local VeriFone representative or service provider, and information on how to order accessories or documentation from VeriFone.

[Chapter 6, Troubleshooting Guidelines](#). Provides troubleshooting guidelines, should you encounter a problem in terminal installation and configuration.

Related Documentation

To learn more about the Vx680 terminal, refer to the following set of documents:

Vx680 Certifications and Regulations Sheet	VPN DOC268-001-EN-A
Vx680 Quick Installation Guide	VPN DOC268-002-EN-A
Vx680 Reference Manual	VPN DOC268-004-EN-A
Vx680 Full-Featured Base and Dongle Quick Installation Guide	VPN DOC268-006-EN-A
Vx680 Standard Base Quick Installation Guide	VPN DOC268-005-EN-A
Verix EOS Volume I: Operating System Programming Manual	VPN DOC00301
Verix EOS Volume II: Operating System and Communications Programmers Manual	VPN DOC00302
Verix EOS Volume III: Operating System Programming Tools Reference Manual	VPN DOC00303



Conventions and Acronyms

This section describes the conventions and acronyms used in this guide.

Document Conventions

Various conventions are used to help you quickly identify special formatting. [Table 1](#) describes these conventions and provides examples of their use.

Table 1 Document Conventions

Convention	Meaning	Example
Blue	Text in blue indicates terms that are cross referenced.	See Conventions and Acronyms .
<i>Italics</i>	Italic typeface indicates book titles or emphasis.	You <i>must</i> install a roll of thermal-sensitive paper in the printer.
Courier	The courier type face is used while specifying onscreen text, such as text that you would enter at a command prompt, or to provide an URL.	<code>http://www.verifone.com</code>
	The pencil icon is used to highlight important information.	RS-232-type devices do not work with the PINpad port.
	The caution symbol indicates possible hardware or software failure, or loss of data.	The terminal is not waterproof or dustproof, and is intended for indoor use only.
	The lightning symbol is used as a warning when bodily injury might occur.	Due to risk of shock do not use the terminal near water.

Acronym Definitions

Various acronyms are used in place of the full definition. [Table 2](#) presents acronyms and their definitions.

Table 2 Acronym Definitions

Acronym	Definitions
AC	Alternating Current
CDMA	Code Division Multiple Access
EMV	Europay MasterCard and VISA
GPRS	General Packet Radio Service
GSM	Global System for Mobile Communication
HDMI	High-Definition Multimedia Interface
ITP	Internal Thermal Printer
LCD	Liquid Crystal Display

Table 2 Acronym Definitions

Acronym	Definitions
LED	Light Emitting Diode
MRA	Merchandise Return Authorization
MSAM	Micromodule-Size Security Access Module
PED	PIN-Entry Devices
PIN	Personal Identification Number
RJ45	Registered Jack 45
RS-232	Recommended Standard 232
SAM	Security Access Module
SIM	Subscriber Identity Module
UART	Universal Asynchronous Transmitter/Receiver
USB	Universal Serial Bus
VPN	VeriFone Part Number
Wi-Fi	Wireless Fidelity

VERIFI
CONFIDENTIAL
DRAFT
REVISION A.3



VERIFONE
CONFIDENTIAL
DRAFT
REVISION A.3



Terminal Overview

This chapter provides a brief description of the V^x680 terminal, the smallest all-in-one wireless handheld payment device. This terminal packs a wallop: large color/touch display, blazing fast processor, abundant memory, the latest PCI 2.0 security, and integrated contactless; all in the same familiar small V^x670 form factor.

The V^x680 terminal is a portable, battery-powered device designed to fit comfortably to the hands and is ideal for consumer-facing applications. It features a vibrant colored 3.5" TFT QVGA display and a backlit spill-resistant keypad.

NOTE



VeriFone ships variants of the V^x680 terminal for different markets. Your terminal may have a different configuration. The following devices may or may not be present: a smart card reader, zero or three MSAM cardholders, and/or a SIM cardholder.



Figure 1 The V^x680 terminal

Features at a glance

- **400 mHz ARM11 RISC processor** delivers **power** and **usability** in a **convenient** “hand-over” design
- **Multi-application** operating environment
- **Advanced memory architecture** to meet tomorrow’s needs with support for 192 MB
- **Backward compatibility** with VeriFone solutions help **reduces development costs**
- **Drop resistant** design minimizes breakage
- **32-bit processing** and **multi-tasking** capabilities
- **Security** architecture exceeds specifications for PCI-PED and sophisticated **file authentication**
- Securely supports and runs **payment** and **value-added applications** along with signature capture
- Offers **unsurpassed performance** on **EMV** smart card transactions
- **Max UI design** provides **large 3.5” color QVGA display**, and large blue backlit keys for easier viewing
- Adds **vibrant color** and **touchscreen** to the smallest purpose-built wireless payment device
- **Multiple connectivity and Contactless** options
- **Spill-resistant design** forces liquid down and off the front of the terminal
- **USB support** for VeriFone peripheral devices

Features and Benefits

VX680 terminals provide the right combination of features and functions including a triple-track magnetic-stripe card reader, smart card reader, integrated PIN pad, color/touch display, optional contactless support, and a quiet yet fast internal thermal printer (ITP).

Exceptional Ease of Use

- Lightweight (less than 1 pound), tapered design, compact, stylish and the ergonomic balance allows convenient terminal hand-off to the consumer for PIN entry or other input
- Large 3.5” color TFT display for boundless application possibilities and easy readability under diverse lighting conditions
- Large, well-placed and blue backlit keys provide improved tactile response to simplify usage and minimize finger slips
- 38 mm diameter paper roll with a trouble-free, drop-in, “clam shell” loading and dual tear bar that allows receipts to be ripped in any direction
- Quiet, fast integrated thermal printer with a rear placement to maximize the user interface area
- Vertical magnetic stripe card reader with an extended blade for optimal card reading
- Touchscreen for icon-based applications or electronic signature capture support
- Optional hands-free holster is available that fits to the server’s or clerk’s belt so that the POS device can be quickly removed and easily handed to the customer

Performance and Durability

- Powerful 400 mHz ARM11 processing completes transactions in seconds
- High-capacity 7.2 V 1800 mA lithium-ion battery can easily be swapped with one hand
- Standard base for drop-and-go charging or optional full-featured base with spare battery charging
- With USB ports for connection to supported USB peripherals
- Rounded corners and drop resistant to 3 feet on concrete floor to minimize breakage
- Sealed MSR blade that locks out moisture for outstanding spill resistance
- 192 MB of memory with optional removable SD flash memory

Security

- PCI PED 2.0 approved for debit and other PIN-based transactions
- EMV Level 1 and 2 Type Approval
- Tamper-resistant construction, SSL protocols, and VeriShield file authentication

VERIFONE
CONFIDENTIAL
DRAFT
REVISION A.3





Terminal Setup

This chapter describes the terminal setup procedure. You will learn about:

- Selecting Terminal Location.
- Unpacking the Shipping Carton.
- Examining Terminal Features.
- Examining Connection Ports.
- Establishing Telephone Line Connections.
- Installing the Paper Roll.
- Installing/Replacing MSAM Cards.
- Installing/Replacing SIM Card (GSM/GPRS Models Only).
- Using the Smart Battery.
- Battery Behavior (No Power Cable).
- Installing the Smart Battery.
- Charging the Smart Battery.
- Connecting the Terminal Power Pack.
- Using the Base Station.
- Placing the Terminal Onto the Base Station.
- Attaching the USB Dongles to the Base Station.
- Charging the Spare Battery on the Base Station.
- Conducting Wireless Transactions.
- Conducting Smart Card Transactions.
- Using the Magnetic Card Reader.

Selecting Terminal Location

Use the following guidelines when selecting a location for your V^x680 terminal.

Environmental Factors

- The V^x680 unit is a portable terminal. Select a flat support surface, such as a countertop or table, to keep the terminal safe in between uses.

- Do not use the terminal where there is high heat, dust, humidity, moisture, or caustic chemicals or oils.
- Keep the terminal away from direct sunlight and anything that radiates heat, such as a stove or motor.
- Do not use the terminal outdoors.

CAUTION

The terminal is not waterproof or dustproof, and is intended for indoor use only. Any damage to the unit from exposure to rain or dust may void any warranty.

Electrical Considerations

- Avoid using this product during electrical storms.
- Avoid locations near electrical appliances or other devices that cause excessive voltage fluctuations or emit electrical noise (for example, air conditioners, electric motors, neon signs, high-frequency or magnetic security devices, or computer equipment).
- Do not use the terminal near water or in moist conditions.

Unpacking the Shipping Carton

Open the shipping carton and carefully inspect its contents for possible tampering or shipping damage. The V^x680 device is a secure product and any tampering may cause the terminal to cease to function properly.

To unpack the Shipping Carton

- 1 Remove and inspect the following items:
 - Terminal
 - Power pack
 - Telephone line cable
 - Power cable
 - Battery pack
 - Paper roll
- 2 Remove all plastic wrapping from the terminal and other components.

- 3 Remove the clear protective film from the LCD screen.



Do not use a terminal that has been damaged or tampered with. The V^X680 terminal comes equipped with tamper-evident labels. If a label or component appears damaged, please notify the shipping company and your VeriFone representative or service provider immediately.

- 4 Save the shipping carton and packing material for future repacking or moving the terminal.

Examining Terminal Features

Before you continue the installation process, notice the features of the V^X680 terminal (see Figure 2).

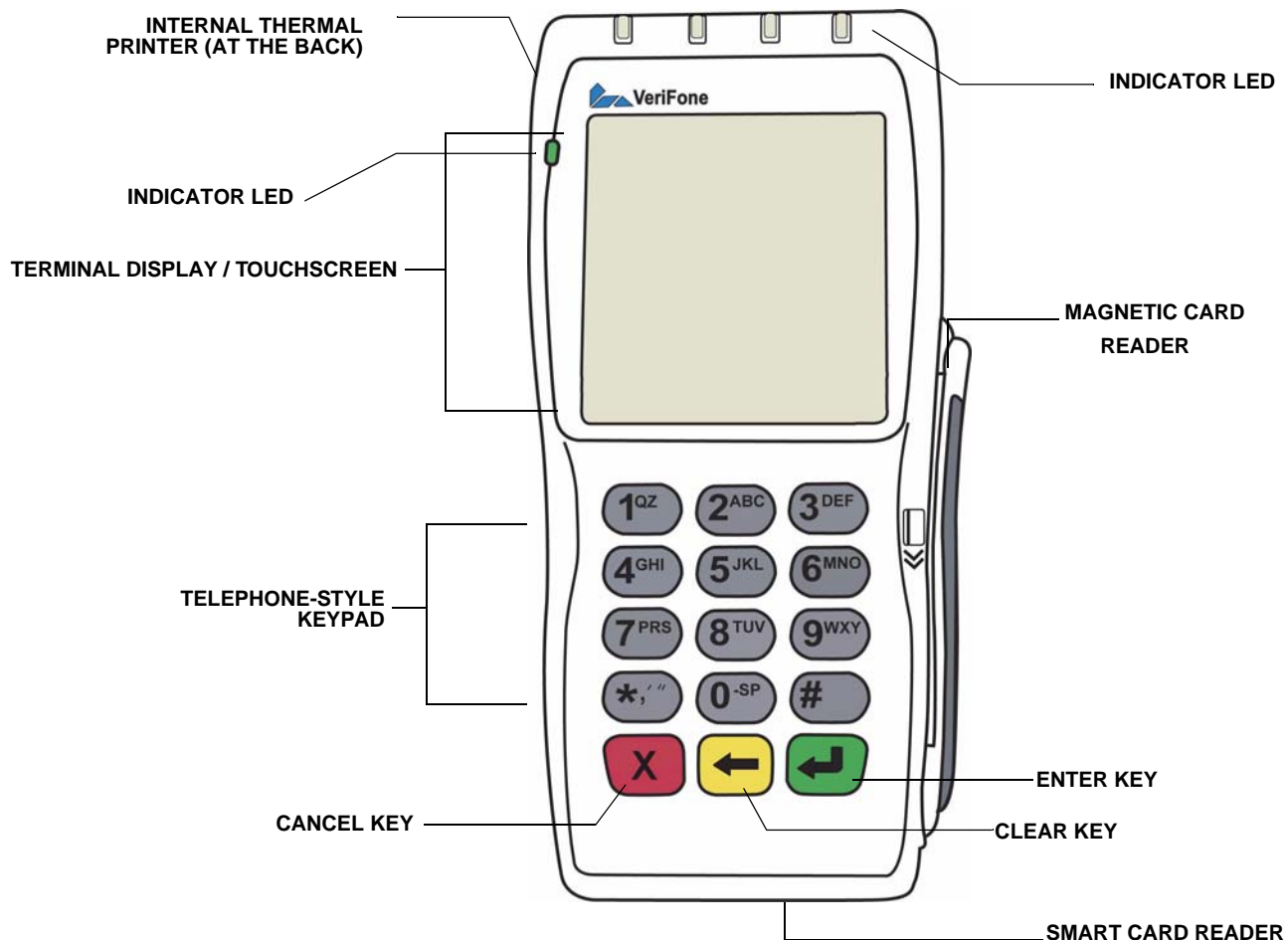



Figure 2 V^X680 Terminal Features (Front Panel)

Front Panel The front panel includes the following features:

- A Large 3.5" color TFT and touchscreen display.

- Two types of keys:
 - A 12-key, **telephone-style keypad** (keypads may vary in style).
 - Three **color-coded function keys** below the keypad (icons at right; from left to right: CANCEL, CLEAR, ENTER). 
- A **magnetic card reader**, built into the right side. Swipe the card using the proper direction, with the magnetic stripe down and facing inward, toward the keypad.
- A green **indicator LED** indicates power is ON.
- Four **indicator LEDs** above the terminal display that indicate what process is being done.
- An **internal thermal printer** at the back of the terminal.
- A **smart card reader**, built into the front of the terminal. For directions on how to use a smart card, see [Conducting Smart Card Transactions](#).
- A **SAM (security access module) compartment**, built into the bottom of the terminal. The Vx680 terminal contains an MSAM cardholder to support stored-value card programs or other merchant card requirements.

NOTE



VeriFone ships variants of the Vx680 terminal for different markets. Your terminal may have a different configuration. The following devices may or may not be present: a smart card reader, or an MSAM cardholder. However, the basic processes described in this guide remain the same, regardless of terminal configuration.

Examining Connection Ports

The Vx680 terminal has one primary port that supports different peripherals through the use of various cables.

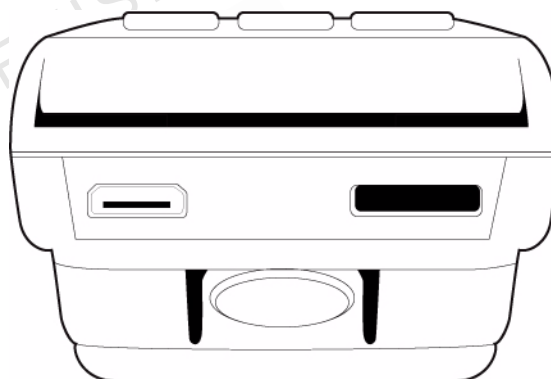

Figure 3 The Vx680 Primary Port (Bottom View)

Power Adapter Cable Each V^x680 terminal comes with a power adapter cable (VPN 08641-01-R) that completes the connection between the power pack and the terminal.

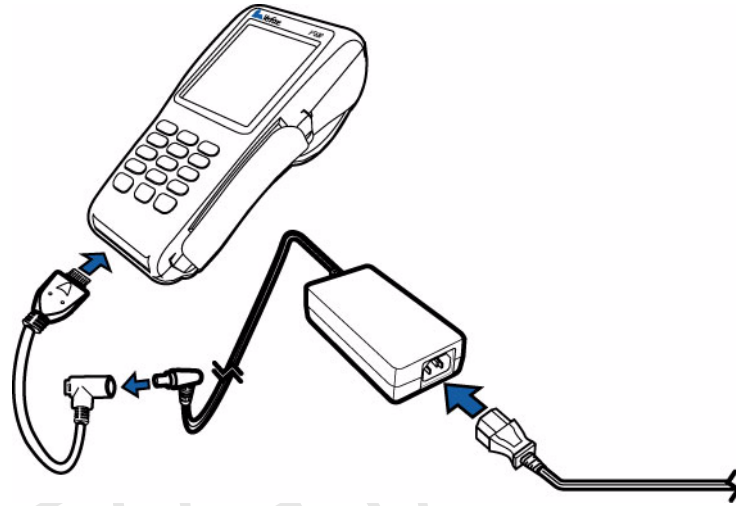

Figure 4 Power Adapter Cable Connection to a V^x680 Terminal

USB Host Cable The V^x680 terminal also provides a 2-Wire USB Host port (VPN 08640-01-R) to support for external peripherals. A connector adaptor provides for standard USB host connection for the Modem Dongle or the RS232 UART Dongle.

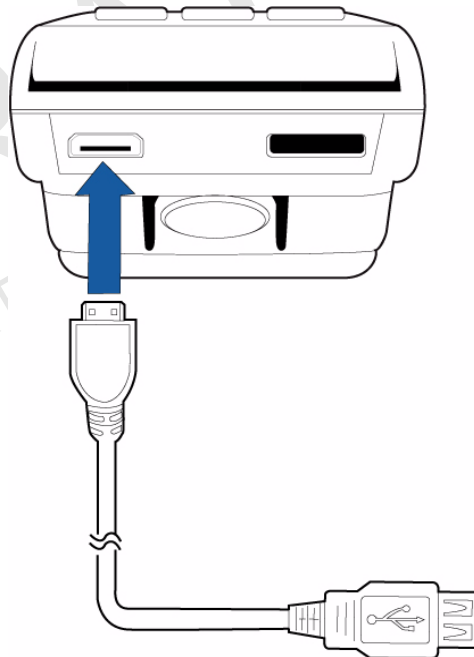

Figure 5 USB Host Cable Connection to a V^x680 Terminal

Multiport Adapter An optional multiport adapter (VPN 08643-01-R) provides connectivity for power, USB Host, USB Device, and COM1 (RS232 UART). This cable is used only for deployment or development purposes.

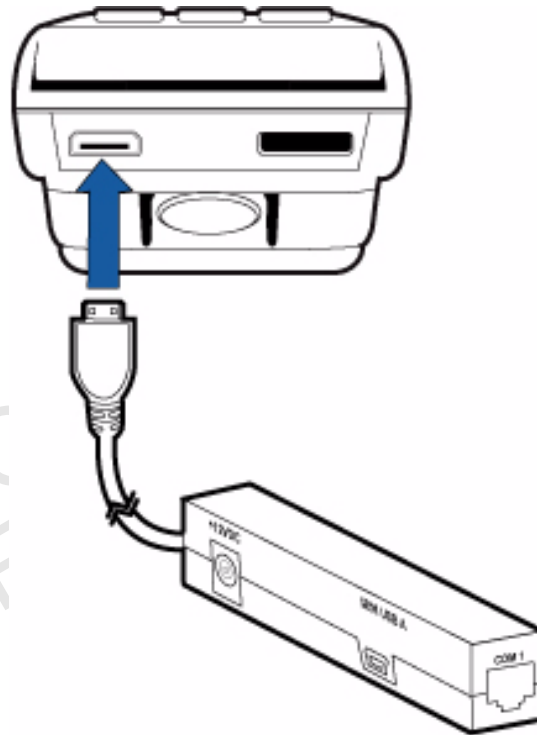

Figure 6 Multiport Adapter Connection to a Vx680 Terminal

NOTE



Other cables are available for different purposes. Check with your local VeriFone representative for further information.

USB Modem Dongle Use the M26-D10-00 USB Modem Dongle to provide the Vx680 terminal with modem communication over a telephone line at speeds of up to 33,600 bps. It can also be connected to the full-feature Base Station when the terminal is in the station (see [Attaching the USB Dongles to the Base Station](#)).

USB Serial Dongle (RS232 UART) The USB Serial Dongle (VPN M267-D01-00) may be purchased with the Vx680 terminal. It is designed to accommodate the RJ45 connector. The USB Serial Dongle can also be connected to the full-feature Base Station when the terminal is placed in the station (see [Attaching the USB Dongles to the Base Station](#)).

NOTE



A Base Station may be purchased with the Vx680 terminal or purchased as a separate option full-feature Base Station has two USB host ports for external dongles as well as a battery charger slot for charging an extra lithium-ion battery pack. A standard Base Station does not have any USB ports and is capable of charging the terminal only and not the extra battery pack.

Establishing Telephone Line Connections

To connect a telephone line:

- 1 Connect one end of the telephone cable to the USB Modem Dongle.
- 2 Connect the USB Modem Dongle to the terminal using the mini-HDMI Connector (VPN 08640-01-R).
- 3 Route the other end of the telephone cable directly to a telephone wall jack.

WARNING



To reduce the risk of fire, use only No. 26 AWG or larger UL Listed or CSA Certified Telecommunication Line Cable.

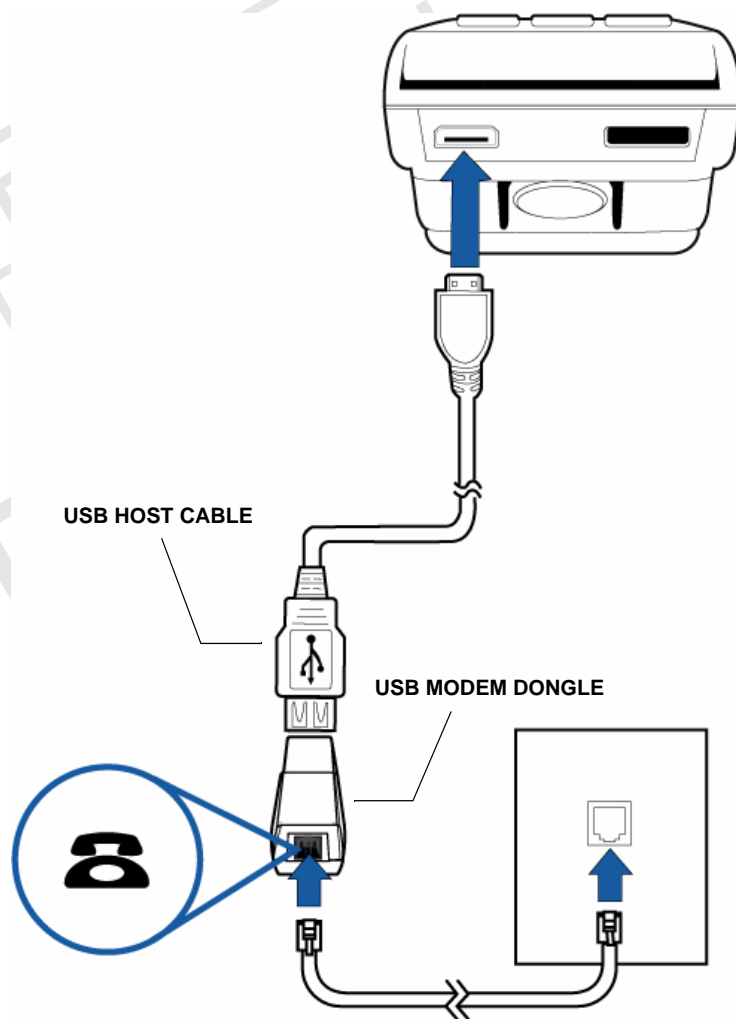

Figure 8 Vx680 USB Modem Dongle Connection



Installing the Paper Roll

A fast, quiet thermal printer is built into the V^x680 terminal. Before you can process transactions that require a receipt or record, you *must* install a roll of thermal-sensitive paper in the printer.

The ITP uses a roll of single-ply, thermal-sensitive paper 57 millimeters (2.24 inches) wide and 38 millimeters in diameter. A pink *out-of-paper* indicator line appears on the edge of the paper approximately 18 inches before the end of the roll. After this line appears, there is enough paper remaining on the roll to conclude at least one transaction.



Poor-quality paper can jam the printer and create excessive paper dust. To order high-quality VeriFone paper, refer to [Accessories and Documentation](#).

Store thermal paper in a dry, dark area. Handle thermal paper carefully: impact, friction, temperature, humidity, and oils affect the color and storage characteristics of the paper.

Never load a roll of paper with folds, wrinkles, tears, or holes at the edges in the print area.

To Install a Paper Roll 1 Gently pull the latch located on the bottom of the terminal to unlock the paper roll cover.

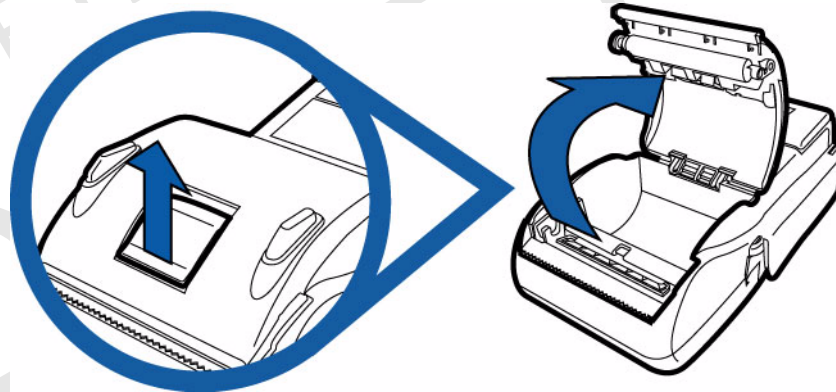

Figure 13 Unlocking the Printer Cover

- 2 Lift the printer cover up and back.

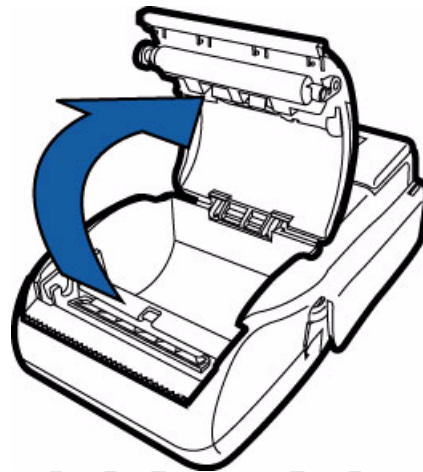

Figure 14 Opening the Printer Cover

- 3 Remove any partial roll of paper in the printer tray by lifting it up.
- 4 Loosen the glued leading edge of the paper or remove the protective strip from the new roll of paper. Unwind the paper roll past any glue residue.
- 5 Hold the roll so the paper feeds from the *bottom* of the roll when the terminal is inverted (see Figure 15).
- 6 Drop the paper roll into the printer tray.

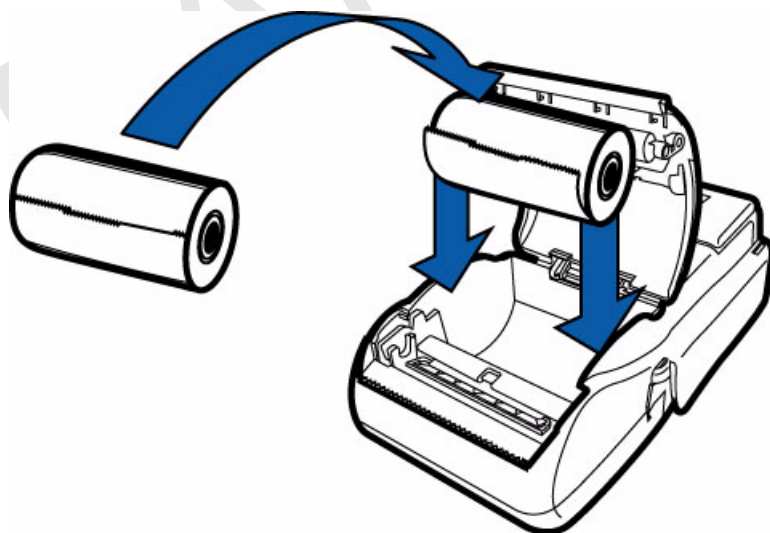

Figure 15 Loading Paper Roll

- 7 Pull paper up past the glue residue on the paper roll.

- 8 Close the paper roll cover by gently pressing directly on the cover until it clicks shut, allowing a small amount of paper past the glue residue to extend outside the printer door.



To prevent damaging the print roller, always gently press down on the paper roll cover to close it.

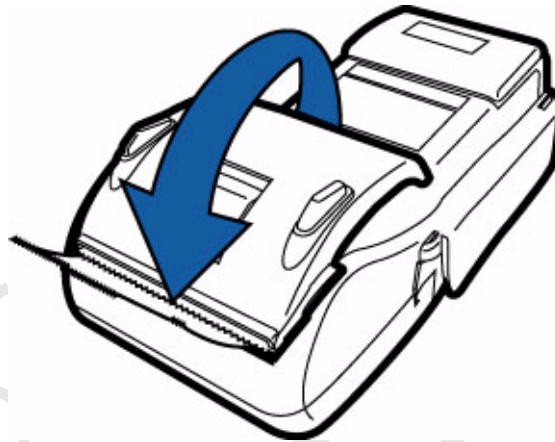

Figure 16 Closing Paper Roll Cover

- 9 Tear the paper off against the serrated plastic strip in the printer.

Installing/ Replacing MSAM Cards

When you first receive your V^x680 terminal, you may need to install an MSAM card or you may need to replace old cards.



Observe standard precautions when handling electrostatically sensitive devices. Electrostatic discharges can damage this equipment. VeriFone recommends using a grounded anti-static wrist strap.

To Install/Replace MSAM

- 1 Power off the terminal.



It is very important that the terminal is powered off before removing the battery.

- 2 Place the terminal upside down on a soft, clean surface to protect the display from scratches.

- 3 Remove the battery.

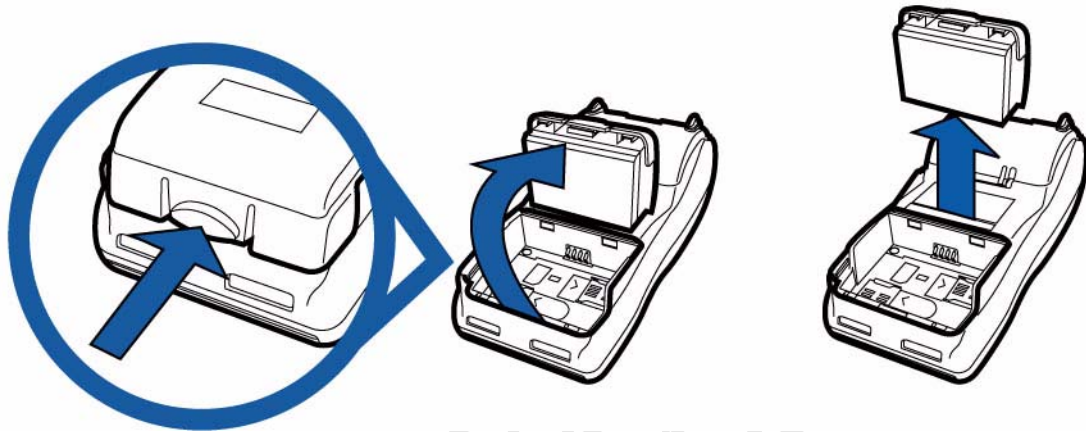

Figure 17 Removing the Smart Battery

- 4 After removing the battery, the MSAM compartment is exposed.
- 5 Remove any previously installed MSAM card by sliding the card from the MSAM cardholder.
- 6 Install an MSAM card by aligning the card and carefully sliding it within the guides on the cover until it is fully inserted (see [Figure 18](#)).

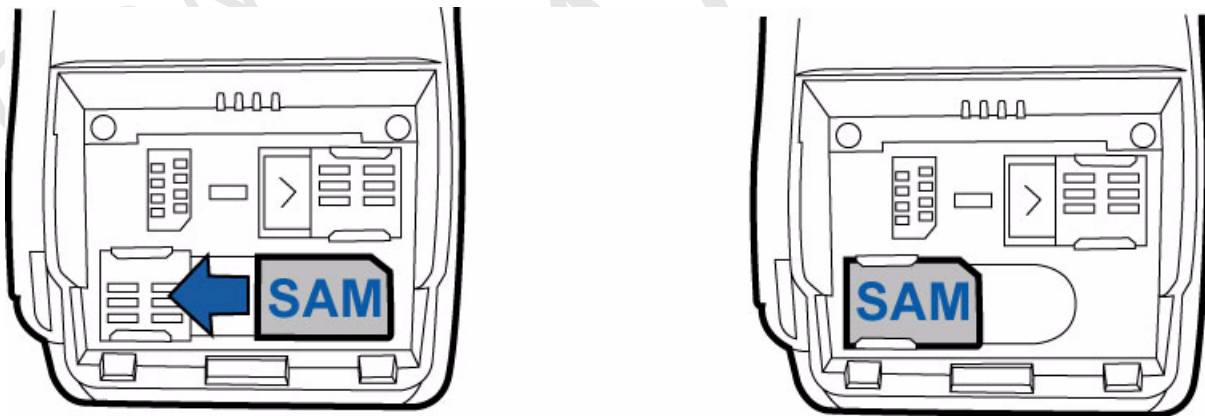

Figure 18 Installing MSAM Card

NOTE



Before inserting the MSAM card, position it as shown in [Figure 18](#), with the card's gold contacts facing the smart card reader end of the terminal. The cardholder connector base has a set of contacts and a notch on one corner to ensure the MSAM card is positioned correctly. The MSAM card has a notch on one corner to ensure that it fits into the connector base in only one way. The MSAM compartment door will not close properly if the MSAM card is installed incorrectly.

- 7 Install the battery (see [Figure 21](#)).

**Installing/
Replacing SIM
Card (GSM/
GPRS Models
Only)**

The Vx680 terminal supports the installation of a SIM (Subscriber Identity Module) card. Use the following procedure to replace or install a SIM card.

- 1 Place the terminal upside down on a soft, clean surface to protect the lens from scratches.
- 2 Remove the battery.

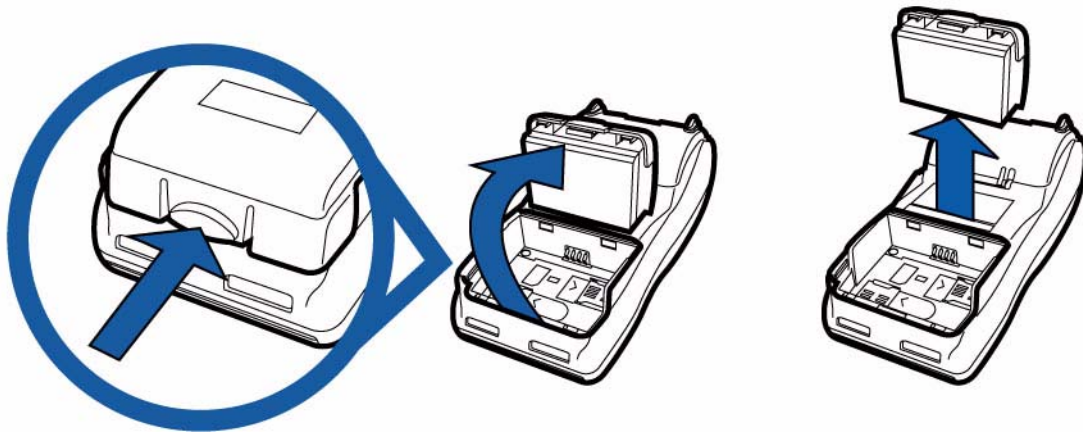

Figure 19 Removing the Smart Battery

- 3 After removing the battery, the SIM compartment is exposed. The SIM card holder is labeled RADIO SIM.
- 4 Insert the SIM into the cardholder.

NOTE



There is only one SIM slot and one SAM slot. Make sure you insert the SIM card into the SIM slot, as shown in Figure 20.

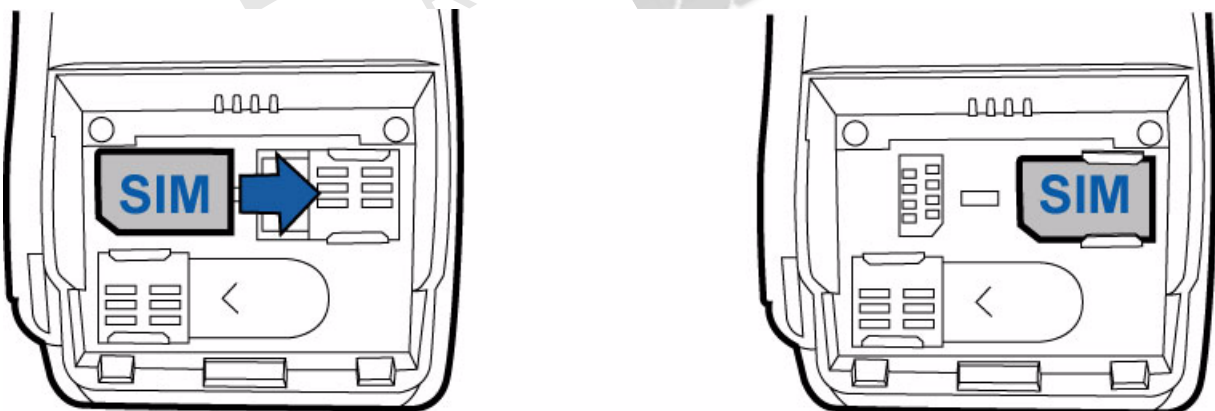

Figure 20 Inserting SIM Card

- 5 Install the battery (see Figure 21).

Using the Smart Battery

The V×680 terminal uses a Li-ion *smart* battery (see [Accessories and Documentation](#) for ordering information). The internal logic of the smart battery prevents both overcharging and undercharging (a fault condition in which the battery level goes well below the minimum acceptable charge and the battery becomes unusable).

NOTE

The V×680 terminal will operate on battery power or on power pack power. The smart battery charger in the terminal will be active whenever the power pack is connected.

Smart Battery Features

The following are features of the smart battery:

- Two Li-ion cells
- A fuel gauge module that:
 - monitors state of charge (voltage and percentage of capacity),
 - communicates with the terminal (charge parameters and status),
 - determines full charge capacity (on charge cycle and uninterrupted discharge cycle), and
 - automatically shuts down when cell voltage is extremely low.
- A safety circuit that:
 - prevents cell damage from overcharge, over-discharge, or overheating, and
 - activates when the battery is left in an unused terminal for extended periods.

NOTE

- Lithium-ion batteries are not affected by shallow charging. Furthermore, when the terminal has no external power source or smart battery, the coin cell battery provides power to the security circuit.
- Uninstalling the battery and unplugging the terminal power pack reduce the life of the coin cell battery, which does not recharge and must be replaced if drained.
- Conserve battery power by turning the V×680 terminal off when not in use. If the terminal is not to be used for an extended period of time, keep the Lithium-ion battery inserted in the terminal, and power up the terminal periodically to check the battery charge. Do not let the battery charge fall below 10% for extended periods of time as this may permanently diminish the battery capacity. Recharge the battery by attaching the power cable to the terminal and plugging the power pack into a wall outlet.

Battery Behavior (No Power Cable)

If you connect the V^x680 to a non-battery power source, the terminal shifts to cabled power mode and starts up automatically, regardless of the battery charge state.

Manual Startup Hold the green key down for about 4 seconds until the terminal displays the startup screen.

NOTE

The 4-second power-up delay is for preventing terminal startup if the green key is accidentally held down. The time required to hold the green key down to power up the terminal is configurable (for more information, see the V^x680 Reference Manual – VPN DOC268-004-EN-A).

When the terminal has power, the terminal lights are activated and the green LED indicator remains lit.

NOTE

If an application is loaded in the terminal, it starts after the initial VeriFone copyright screen and usually displays a unique copyright screen. If no application is loaded in the terminal, **DOWNLOAD NEEDED** appears on screen after the initial VeriFone copyright screen.

Manual Shutdown Hold the red key down for about 4 seconds until the terminal displays the shutdown verification screen. Keep holding the red key until the V^x680 terminal shuts down.

NOTE

- The 4-second shutdown delay is for preventing terminal shutdown if the red key is accidentally held down. The time required to hold the red key down to shut down the terminal is configurable (for more information, see the V^x680 Reference Manual – VPN DOC268-004-EN-A).
 - When the terminal has no power, the screen is blank and the green LED indicator is not lit.
-

Installing the Smart Battery

The V×680 smart battery fits in a slot on the back of the V×680 terminal, as shown in Figure 21. The locking tab clicks when the battery is in place. The slot is keyed, so that there is only one way to insert the battery.

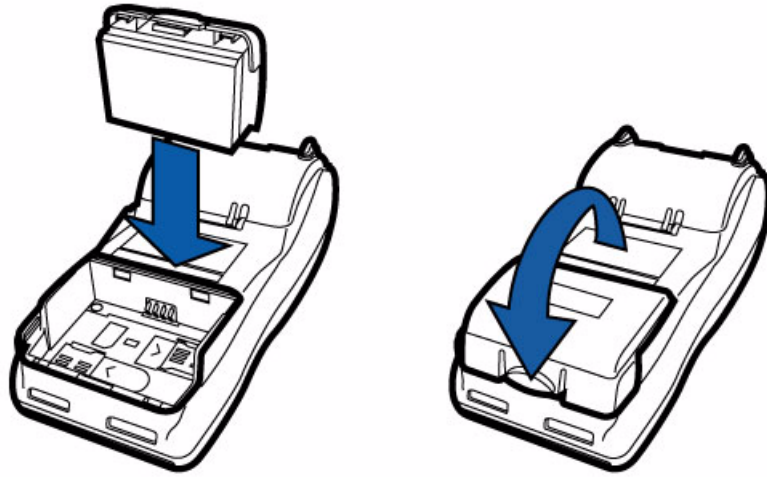

Figure 21 Installing the Smart Battery

Removal To remove the V×680 smart battery, press the locking tab and pull the smart battery from its slot.

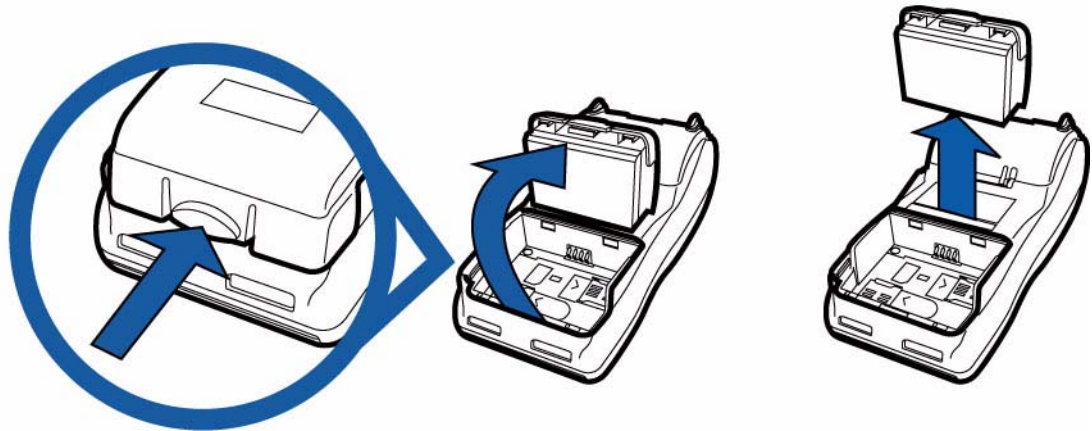

Figure 22 Detaching the Smart Battery from the V×680 Terminal

Connecting the Terminal Power Pack

When you have finished installing the smart battery, you are ready to connect the V^x680 terminal to the provided power source for initial charging.

CAUTION



Using an incorrectly rated power supply may damage the terminal or cause it not to work as specified. Before troubleshooting, ensure that the power supply being used to power the terminal matches the requirements specified on the bottom of the terminal. (See [Chapter 3, Specifications](#) for detailed power supply specifications.) Obtain the appropriately rated power supply before continuing with troubleshooting.

The V^x680 unit comes with a universal input power pack capable of operating from voltages of 100VAC to 240VAC.

To Connect the Terminal Power Pack

- 1 Insert the round barrel connector into the power port in the connector, as shown in [Figure 23](#).

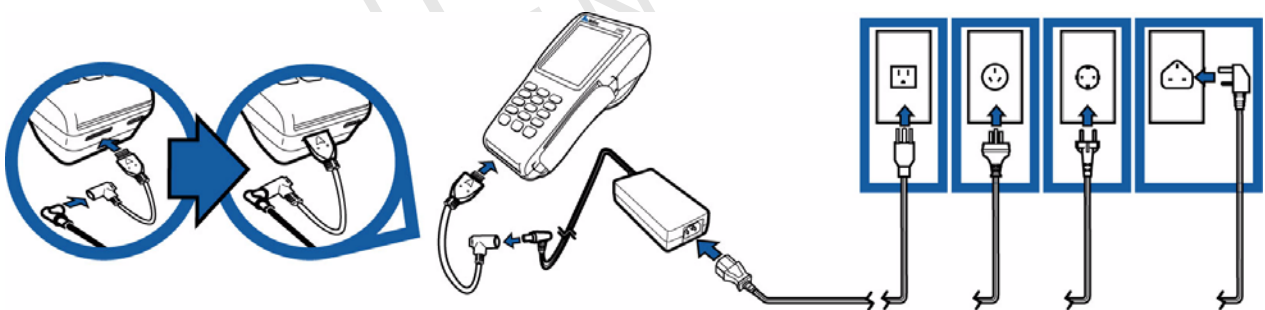

Figure 23 V^x680 Power Pack Connection

- 2 Insert the AC power cable into the power pack.
- 3 Plug the AC power cable into a wall outlet or powered surge protector.

WARNING



Do not plug the power pack into an outdoor outlet or operate the terminal outdoors.

During a transaction, disconnecting the power by removing the battery or unplugging the terminal from a wall power while at very low battery charge may cause transaction data files not yet stored in the terminal memory to be lost.

NOTE



To protect against possible damage caused by lightning strikes and electrical surges, consider installing a power surge protector.

When the terminal has power, the terminal lights are activated and the LED indicator remains lit.

If an application is loaded in the terminal, it starts after the initial VeriFone copyright screen and usually displays a unique copyright screen. If no application is loaded in the terminal, **DOWNLOAD NEEDED** appears on screen after the initial VeriFone copyright screen.

Charging the Smart Battery

After unpacking your Vx680 terminal, install the battery and connect the power pack to the unit for 6 hours or until fully charged.

NOTE



The Vx680 terminal's smart battery is also charged when the terminal is in the Base Station. For more information, see [Placing the Terminal Onto the Base Station](#).

The smart battery has a safety circuit to protect the Li-ion cells from overcharging and over-discharging. If the battery is over-discharged, the safety circuit shuts down the battery. The battery must then be recharged to restore operation.

NOTE



The Vx680 terminal automatically shuts off when the smart battery reaches the *critically low* charge state. If this occurs, the smart battery must be recharged for a minimum of 1/2 hour before it can power the terminal. *It may take several recharge attempts to reset the safety circuit* when charging a smart battery that has been discharged below this critical state.

Battery Life

The Vx680 smart battery can be charged and discharged hundreds of times, but will eventually wear out. When operating times are noticeably shorter than usual, it is time to buy a new battery (see [Accessories and Documentation](#) for ordering information).

WARNING



Do not dispose of batteries in a fire. Li-ion batteries must be recycled or disposed of properly. Do not dispose of Li-ion batteries in municipal waste sites.



Using the Base Station

The primary purpose of the Base Station is to charge the terminal battery and provide a docking station for the terminal after being used in pay-at-table environments. The Base Station can be positioned on a countertop or mounted to the wall.

There are two types of Base Stations, the standard model and the full-feature model.

Standard Base Station

The standard Base Station can charge the V^x680 terminal. However, it does not have any external ports and has a single LCD to indicate power status.

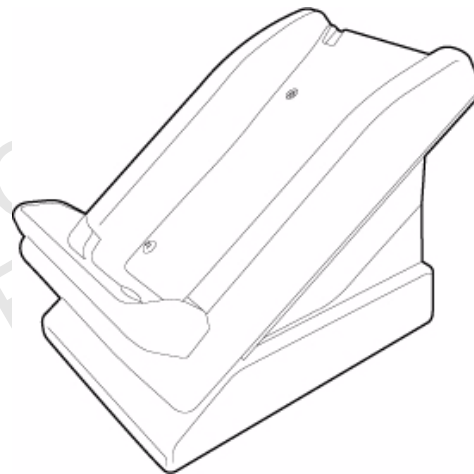

Figure 24 The V^x680 Standard Base Station

Full-Feature Base Station

The full-feature Base Station can charge the V^x680 terminal while charging an extra battery pack. In addition, it has two USB ports for external dongles, together with one LED for power indication and another LED for the charger status.

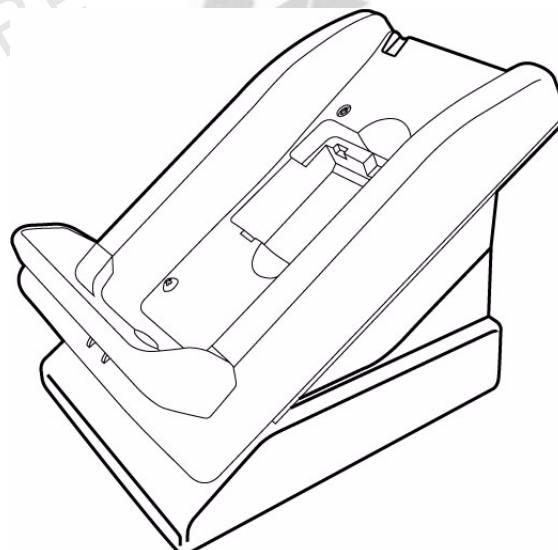

Figure 25 The V^x680 Full-Feature Base Station

For more information on charging the spare battery on the full-feature Base Station and connecting external dongles to the USB ports, see [Charging the Spare Battery on the Base Station](#) and [Attaching the USB Dongles to the Base Station](#).

Powering Up the Base Station

Use the procedure in this section to connect the V×680 Base Station to a power source.

- 1 Insert the round barrel connector of the power pack into the power port at the back of the Base Station.

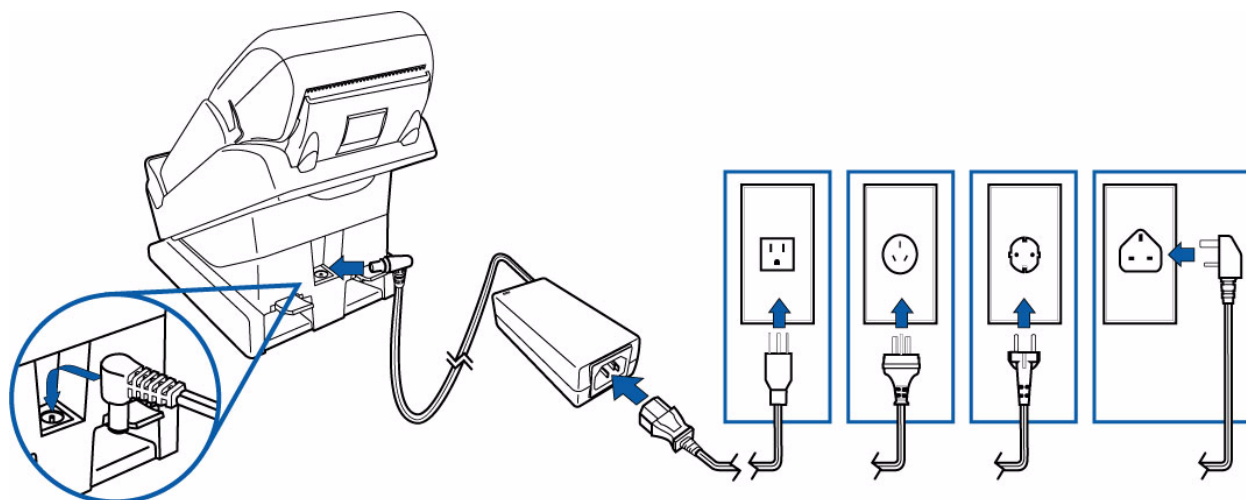

Figure 26 Connecting the Base Station to a Power Source

- 2 Insert the AC power cable into the power pack.
- 3 Plug the AC power cable into a wall outlet or power surge protector.
- 4 Confirm that the Base Station is powered up as indicated by the solid green LED.

Placing the Terminal Onto the Base Station

The V×680 terminal can be placed on the Base Station when not in use for continuous charging of its battery. External peripherals can also be attached to the terminal via USB dongles while it is on the Base Station (see [Attaching the USB Dongles to the Base Station](#)).

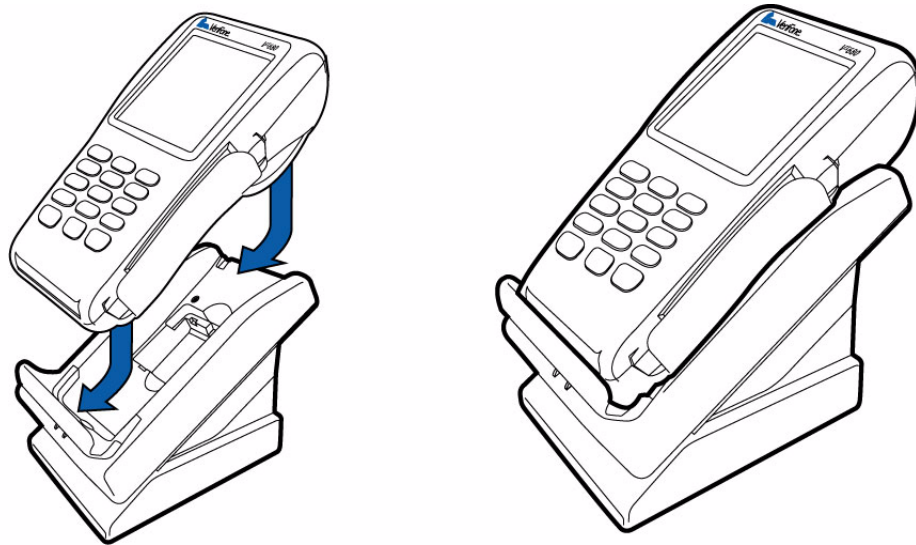

Figure 27 Placing the V×680 terminal onto the Base Station

NOTE



The full-feature Base Station can also charge a spare battery while it charges the battery attached to the terminal (see [Charging the Spare Battery on the Base Station](#)).

To protect against possible damage caused by lightning strikes and electrical surges, consider installing a power surge protector.

WARNING



Do not plug the power pack into an outdoor outlet or operate the terminal outdoors.

Disconnecting the power during a transaction may cause transaction data files not yet stored in terminal memory to be lost.

Attaching the USB Dongles to the Base Station

While the V×680 terminal is resting on the Base Station, you can drive external peripherals through the use of USB dongles. Only one Modem Dongle and one Serial Dongle can be connected to the Base Station. A second Modem Dongle or a second Serial Dongle will be ignored by the terminal.

NOTE



The full-feature Base Station has USB ports for two external dongles. The standard Base Station does not have USB ports.

- 1 Insert the USB dongle into the USB port located at the back of the Base Station.

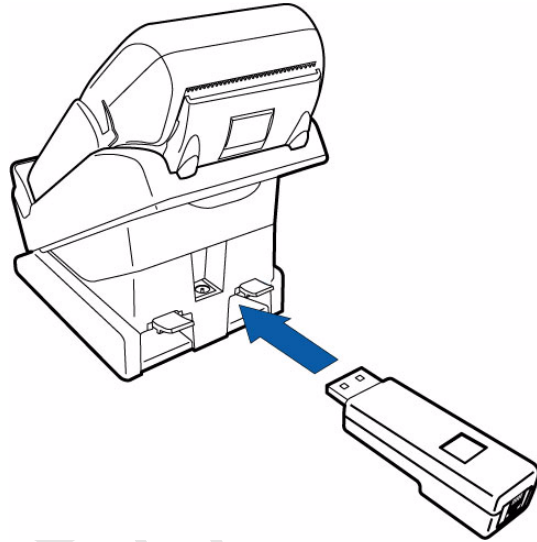

Figure 28 Inserting External Dongle Into USB Port

- 2 After inserting the external dongle into the USB port, place the V^x680 terminal onto the Base Station (see [Powering Up the Base Station](#)).
- 3 Connect the peripheral to the external dongle.

Charging the Spare Battery on the Base Station

The full-feature Base Station can charge the V^x680 terminal while charging an extra battery pack.

- 1 Connect the Base Station to a power source (see [Powering Up the Base Station](#))
- 2 Place the spare battery pack onto the Base Station as shown in [Figure 29](#).

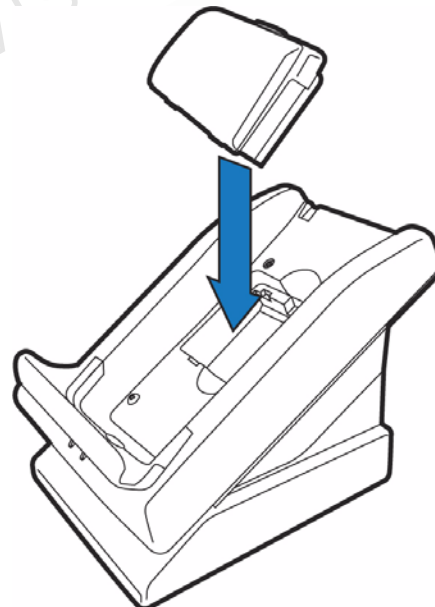

Figure 29 Putting Spare Battery Pack Into the Base Station

- 3 Place the V×680 terminal onto the Base Station to charge both the spare and installed battery packs at the same time.

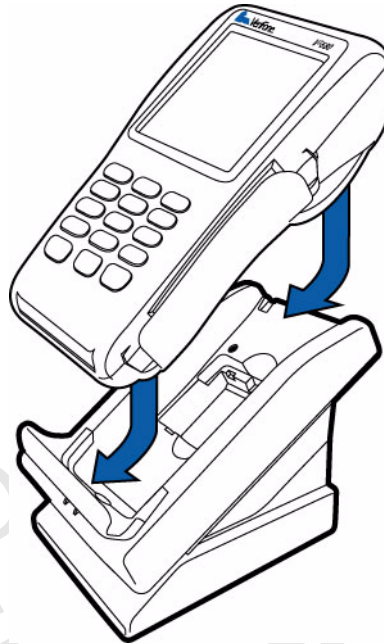

Figure 30 Charging the Spare and Installed Battery Simultaneously

Conducting Wireless Transactions

To conduct a wireless transaction:

- Ensure the terminal is in an optimal position for transmitting.
- Follow the on-screen instructions provided with your application.

Conducting Smart Card Transactions

The smart card transaction procedure may vary from one application to another. Verify the procedure with your application provider before performing a smart card transaction.

To Conduct a Smart Card Transaction

- 1 Position a smart card with the contacts facing upward (see [Figure 31](#)).
- 2 Insert the smart card into the smart card reader slot in a smooth, continuous motion until it seats firmly.

- 3 Remove the card only when the application indicates the transaction is complete.

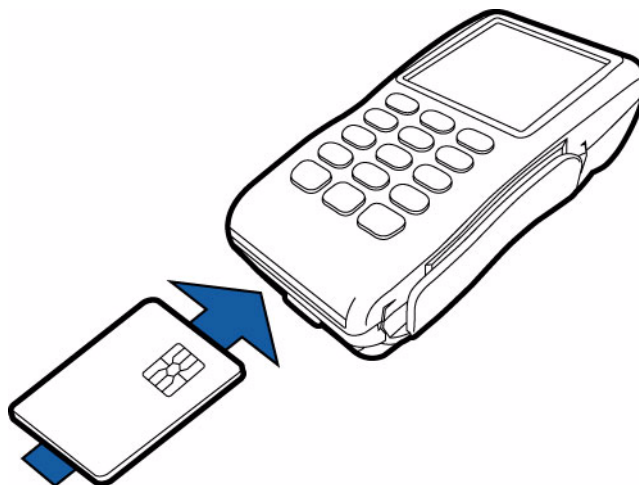

Figure 31 Inserting a Smart Card



Leave the smart card in the card reader until the transaction is complete. Premature card removal will invalidate the transaction.

Using the Magnetic Card Reader

The V^x680 terminal supports credit/debit card transactions.

To Conduct a Credit/Debit Card Transaction

- 1 Position a magnetic card with the stripe in the card reader and facing inward, toward the keypad.
- 2 To ensure a proper read of the magnetic swipe card, the user should insert the magnetic card from the top of the unit, as shown in [Figure 32](#).

- 3 Swipe the card through the magnetic card reader.

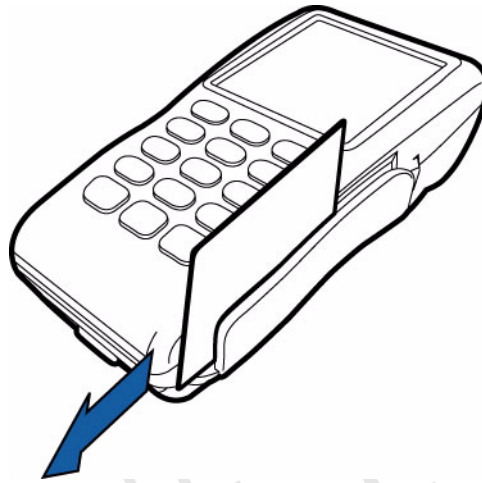

Figure 32 Using the Magnetic Card Reader

VERIFONENTIAL
CONFIDENTIAL
DRAFT
REVISION A.3

VERIFONE
CONFIDENTIAL
DRAFT
REVISION A.3



Specifications

This chapter discusses power requirements, dimensions, and other specifications of the V^X680 terminal.

Power 12V DC 2.0 A

DC Power Pack UL, ITE listed, LPS power supply:

a Input rated: 100 - 240V AC, 50/60 Hz

b Output rated: 12V DC 2.0 A

Barrel connector polarity:



Temperature

- Operating temperature: -10° to 50° C (14° to 122° F)
- Relative humidity: 5% to 90%; non-condensing

External Dimensions

- Length: 168 mm (6.6 in)
- Width: 82 mm (3.2 in)
- Depth: 58 mm (2.3 in)

VERIFONE
CONFIDENTIAL
DRAFT
REVISION A.3



Maintenance

The V^x680 terminal and base stations have no user-maintainable parts.

Cleaning the Terminal

To clean the terminal and base station, use a clean cloth slightly dampened with water and a drop or two of mild soap. For stubborn stains, use alcohol or an alcohol-based cleaner.



Never use thinner, trichloroethylene, or ketone-based solvents – they may cause deterioration of plastic or rubber parts.

Do not spray cleaners or other solutions directly onto the keypad or terminal display.

Terminal Contacts

Gently swab the contacts with alcohol or contact cleaner to remove the dirt. It is important that the exposed contacts of the V^x680 battery stay clean and unbent.



Avoid touching the contacts of the V^x680 battery and the recessed area on the terminal. Finger oils tarnish contacts, causing bad connections. When operating on battery power and experiencing a high occurrence of bad or incomplete data transfers, clean the contacts.

Smart Card Reader

Do not attempt to clean the smart card reader. Doing so may void any warranty. For smart card reader service, contact your VeriFone distributor or service provider.

VERIFONE
CONFIDENTIAL
DRAFT
REVISION A.3



VeriFone Service and Support

For V^x680 terminal problems, contact your local VeriFone representative or service provider.

For V^x680 product service and repair information:

- USA – VeriFone Service and Support Group, 1-800-VeriFone (837-4366), Monday - Friday, 8 A.M. - 8 P.M., Eastern time
- International – Contact your VeriFone representative

Returning a Terminal or Smart Battery for Service

Before returning a V^x680 terminal, smart battery, or base station to VeriFone, you must obtain an MRA number. The following procedure describes how to return one or more V^x680 terminals, smart batteries, or base stations for repair or replacement (U.S. customers only).

NOTE

Customers outside the United States are advised to contact their local VeriFone representative for assistance regarding service, return, or replacement of terminals or batteries.

To Return a Terminal for Service

- 1 Get the following information from the printed labels on the bottom of *each* V^x680 terminal, smart battery, or sled module to be returned:
 - Product ID, including the model and part number. For example, “V^x680” and “M268-XXX-XXX-xxx.”
 - Serial number (S/N nnn-nnn-nnn)
- 2 Obtain the MRA number(s) by completing one of the following:
 - a Call VeriFone toll-free within the United States at 1-800-VeriFone and follow the automated menu options.
 - Select the MRA option from the automated message. The MRA department is open Monday to Friday, 8 A.M.–8 P.M., Eastern Time.
 - Give the MRA representative the information you gathered in Step 1. If the list of serial numbers is long, you can fax the list, along with the information gathered in Step 1, to the MRA department at 727-953-4172 (U.S.).
 - b Address a fax to “VeriFone MRA Dept.” with the model and part number(s)
 - Include a telephone number where you can be reached and your fax number.

- c Complete the Inquiry Contact Form at http://www.verifone.com/aboutus/contact/contact_form.cfm.
 - Address the Subject box with to “VeriFone MRA Dept.”
 - Reference the model and part number in the Note box.



One MRA number must be issued for each V×680 terminal you return to VeriFone, even if you are returning several of the same model.

- 3 Describe the problem(s).
- 4 Provide the shipping address where the repaired or replacement unit must be returned.
- 5 Keep a record of the following items:
 - Assigned MRA number(s).
 - VeriFone serial number assigned to the V×680 terminal, smart battery, or base station you are returning for service or repair (terminal serial numbers are located on the bottom of the unit).
 - Shipping documentation, such as air bill numbers used to trace the shipment.
 - Model(s) returned (model numbers are located on the VeriFone label on the bottom of the V×680 terminal).

Accessories and Documentation

VeriFone produces the following accessories and documentation for the V×680 terminal. When ordering, please refer to the part number in the left column.

- VeriFone online store at www.store.verifone.com
- USA – VeriFone Customer Development Center, 800-VeriFone (837-4366), Monday - Friday, 7 A.M. - 8 P.M., Eastern time
- International – Contact your VeriFone representative

Power Pack

Contact your local VeriFone distributor to determine which power pack or power cable fits your needs.

CPS11224-3B-R DC power pack (universal)

21973-01 AC power cable (US)

Thermal Printer Paper

CRM0047-20 Thermal paper in 20-roll bulk package

VeriFone Cleaning Kit

02746-01 Cleaning Kit

Spare Battery

24016-01-R V×680 spare battery

USB Host Cable	08640-01-R	V×680 USB Host Cable
Modem Dongle	24123-01-R	V×680 Modem Dongle
Serial Dongle	24122-01-R	V×680 Serial Dongle
Telephone Line Cable	00124-17	2.1-meter (7-foot) telephone line cable, black, with modular RJ11-type connectors

Documentation

V×680 Certifications and Regulations Sheet	VPN DOC268-001-EN-A	
V×680 Quick Installation Guide	VPN DOC268-002-EN-A	
V×680 Reference Manual	VPN DOC268-004-EN-A	
V×680 Full-Featured Base and Dongle Quick Installation Guide	VPN DOC268-006-EN-A	
V×680 Standard Base Quick Installation Guide	VPN DOC268-005-EN-A	
Verix EOS Volume I: Operating System Programmers Manual	VPN DOC00301	
Verix EOS Volume II: Operating System and Communication Programmers Manual	VPN DOC00302	
Verix EOS Volume III: Operating System Programming Tools Reference Manual	VPN DOC00303	

CONFIDENTIAL
 DRAFT
 REVISION A.3

VERIFONE
CONFIDENTIAL
DRAFT
REVISION A.3



Troubleshooting Guidelines

The troubleshooting guidelines provided in the following section are included to help you install and configure your V^x680 terminal successfully. Typical examples of malfunction you may encounter while operating your V^x680 terminal and steps you can take to resolve them are listed in this chapter.

If the problem persists even after performing the outlined guidelines or if the problem is not described below, contact your local VeriFone representative for assistance.

NOTE



The V^x680 terminal comes equipped with tamper-evident labels. The V^x680 unit contains no user serviceable parts. Do not, under any circumstance, attempt to disassemble the terminal. Perform only those adjustments or repairs specified in this guide. For all other services, contact your local VeriFone service provider. Service conducted by parties other than authorized VeriFone representatives may void any warranty.

CAUTION



Use only a VeriFone-supplied power pack. Using an incorrectly rated power supply may damage the terminal or cause it not to work as specified. Before troubleshooting, ensure that the power supply being used to power the terminal matches the requirements specified on the bottom of the terminal. (See [Chapter 3, Specifications](#), for detailed power supply specifications.) Obtain the appropriately rated power supply before continuing with troubleshooting.

Terminal Does Not Start

- Ensure that the smart battery charge state is not below the critically low level.
- Recharge or replace the smart battery.
- Ensure that you pressed the green ENTER/ON key for approximately 4 seconds, until the unit lights up.

Terminal Display Does not Show Correct/Readable Info

- Recharge or replace the battery.
- Connect the V^x680 terminal into a known-good power supply (if you have one) to see if this clears the problem.
- If the problem persists, contact your local VeriFone representative for assistance.

Smart Battery Will Not Charge

The Vx680 smart battery must initially receive a full charge to ensure proper operation.

NOTE



- Allow the Vx680 terminal to remain connected to the power pack for 6 hours to ensure the battery receives a full charge.
- Lithium-ion batteries are not affected by shallow charging. Furthermore, when the terminal has no external power source or battery the coin cell battery provides power to the security circuit.
- Uninstalling the battery and unplugging the terminal power pack reduce the life of the coin cell battery, which does not recharge and must be replaced if drained.
- Conserve battery power by turning the Vx680 terminal off when not in use. If the terminal will not be used for an extended period of time, keep the Lithium-ion battery inserted in the terminal, and power up the terminal periodically to check the battery charge. Do not let the battery charge fall below 10% for extended periods of time as this may permanently diminish the battery capacity. Recharge the battery by attaching the power cable to the terminal and plugging the power pack into a wall outlet.
- The Vx680 terminal automatically shuts off when the smart battery reaches the *critically low* charge state. If this occurs, the smart battery must recharge a minimum of 1/2 hour before it can power the terminal. *It may take several recharge attempts to reset the safety circuit* when charging a smart battery that has been discharged below this critical state.

Spare Battery in Base Station Will Not Charge

When the spare battery is installed in the base for charging, the Base LED will flash amber if the battery is charging, or stay solid green if the battery is fully charged. If the battery is not charged and the LED does not flash amber, check the contacts on the battery and in the terminal base to make sure they are clean. Also, try charging a known good battery to see if the problem is with the base or with the battery. If the problem persists, contact your local VeriFone representative.

Blank Display

When the V×680 terminal display screen does not show correct or clearly readable information:

- The battery pack may not be connected properly. Remove and reinstall the battery pack.
- Check terminal power connection.
- Remove and reapply power to the terminal.
- If the problem persists, contact your local VeriFone service provider.

Terminal Does Not Dial Out

If the terminal does not dial out:

- Check the telephone line connections.
- Check that the telephone line is working by plugging it into a working telephone and listening for a dial tone.
- Replace the telephone cable that connects the terminal with a cable you know is working correctly.
- If the problem persists, contact your local VeriFone service provider.

Printer Does Not Print

If the printer does not work properly:

- Make sure the battery is properly installed in the terminal. The printer will not print if there is no battery in the terminal.
- Check battery status or terminal power connection. The printer will not print if there is an insufficient charge remaining in the battery to complete the print operation.
- Check if the printer is out of paper (slow red blinking light) and that the roll is properly installed. Open the paper roll cover and install a new roll of printer paper or ensure that the roll is feeding correctly. A solid red indicator light indicates a printer error.
- Verify that the printer door is properly latched.
- If the problem persists, contact your VeriFone distributor or service provider.

Printer Paper Jam

If paper jams inside the printer:

- Press the button at the bottom of the terminal to unlatch the paper roll cover, then open the cover.
- Remove the damaged paper from the paper roll and clear the feed mechanism.
- Install a roll of printer paper, as described in [Installing the Paper Roll](#).

- If the problem persists, it may be due to poor paper quality. Install a new roll of higher-quality paper.

WARNING

Poor-quality paper may jam the printer. To order high-quality VeriFone paper, refer to [Accessories and Documentation](#).

Keypad Does Not Respond

If the keypad does not respond properly:

- Check the terminal display. If it displays the wrong character or nothing at all when you press a key, follow the steps outlined in [Transactions Fail To Process](#).
- If pressing a function key does not perform the expected action, refer to the user documentation for that application to ensure you are entering data correctly.
- If the problem persists, contact your local VeriFone representative.

Transactions Fail To Process

There are several reasons why the terminal may not be processing transactions. Use the following steps to troubleshoot failures.

Check the Magnetic Card Reader

- Perform a test transaction using one or more different magnetic stripe cards to ensure the problem is not a defective card.
- Ensure that you are swiping cards properly. With the V^X680 card reader, the black magnetic stripe on the card should face down and inward, toward the keypad and must be inserted from the top of the terminal (see [Figure 32](#)).
- Process a transaction manually, using the keypad instead of the card reader. If the manual transaction works, the problem may be a defective card reader.
- Contact your VeriFone distributor or service provider.
- If the manual transaction does not work, proceed to [Check the Telephone Line](#).

Check the Smart Card Reader

- Perform a test transaction using several different smart cards to ensure the problem is not a defective card.
- Ensure that the card is inserted correctly and that the card is not removed prematurely.
- Ensure the MSAM cards are properly inserted in the cardholders and that the cardholders are properly secured (see [Installing/Replacing MSAM Cards](#)).
- Contact your VeriFone distributor or service provider.
- If the manual transaction does not process, proceed to [Check the Telephone Line](#).

Check the Telephone Line

- Disconnect the telephone line from the Vx680 terminal and connect it to a working telephone to check for a dial tone. If there is no dial tone, replace the telephone cable.
- If the problem appears to be with the telephone line, check with the party you are trying to call to see if their system is operational. If they are not experiencing difficulties with their line, contact the telephone company and have your line checked.
- If the telephone line works, contact your local VeriFone representative for assistance.

COV
L
REVISION

VERIFONE
CONFIDENTIAL
DRAFT
REVISION A.3





A

- accessories **50**
 - documentation **51**
 - ordering **51**
 - power packs **50**
 - telephone line cord **51**
 - thermal printer paper **50**
 - VeriFone cleaning kit **50**

B

- Base Station **37**
- batteries
 - extending the battery life **36**
 - See also smart battery
- battery mode
 - Vx680 **33**
- Bluetooth® Comm Base Station
 - connector sockets **23**
 - mounting the **24**
 - power connection to the **25**
 - requirements **16**
 - telephone line connection to the **25**
 - use of **21**

C

- cleaning kit **50**
- cleaning kits
 - ordering **50**
- connection ports **18**
- contact VeriFone **49**

D

- dial out problems
 - troubleshooting **55**
- displays
 - troubleshooting **53, 55**
- documentation **50**
 - acronym definitions **8**
 - conventions **8**
 - ordering **51**

E

- electrical considerations **16, 29**
- electrostatic discharges **29**
 - prevention **29**
- environmental factors **15**

F

- full-feature Base Station **37**

H

- HDMI **8, 22**

I

- installation **11**
 - connecting the terminal power pack **35**
 - connecting the terminal to a telephone line **22**
 - MSAM cardholder **29**
 - MSAM card **29**
 - terminal location **15**
 - unpacking the shipping carton **16**

K

- keypads
 - troubleshooting **56**

M

- maintenance
 - cleaning the terminal **47**
 - cleaning the terminal contacts **47**
 - returning a battery for repair or replacement **49**
 - returning a terminal for repair or replacement **49**
- MSAM cardholder **29**
- MSAM card **29**

P

- paper jams
 - troubleshooting **55**
- paper rolls
 - for thermal printers **27, 56**
 - installation **27**
- power adapter cables **19**

- power packs
 - AC version **50**
 - connecting **35**
 - DC version **50**
 - ordering **50**
- printer paper
 - ordering **50**
- printers
 - troubleshooting **55**

R

RS232 UART **20**

S

- service
 - returning a battery for repair or replacement **49**
 - returning a terminal for repair or replacement **49**
- SIM cards
 - for GSM models **31**
- smart battery **36**
 - battery life **36**
 - charging **36**
 - conserving power **32**
 - disposal **36**
 - features **32**
 - installation **34**
 - recharging **36**
 - removal **34**
 - troubleshooting **54**
- spare batteries
 - charging on the Full-Featured Base Station **40**
 - ordering **50**
- specifications
 - DC power pack **45**
 - power **45**
 - temperature **45**
- standard Base Station **37**

T

- technical support
 - contacting VeriFone **49**
 - returning a battery for repair or replacement **49**
 - returning a terminal for repair or replacement **49**
- telephone line connections **22**
- telephone line cords
 - ordering **51**

- terminal features
 - general **17**
- terminals
 - accessories **50**
 - benefits **12**
 - cleaning **47**
 - documentation **50**
 - electrical considerations **16**
 - environmental factors **15**
 - features **17**
 - repair **49**
 - replacement **49**
 - service and support **49**
 - troubleshooting **53, 55**
- thermal paper
 - ordering **50**
- thermal printer paper
 - storage **27**
- thermal printers
 - about the thermal printer paper **27, 56**
 - paper jams **55**
 - troubleshooting **55**
- transactions
 - Bluetooth® **42**
 - smart cards **41**
 - wireless **41**
- troubleshooting
 - batteries **54**
 - displays **53, 55**
 - guidelines **53**
 - keypads **56**
 - printers **55**
 - terminal transactions **56**
 - terminals **53, 55**

U

- USB dongles
 - modem **20**
 - serial **20**
- USB host cable **19, 51**
- USB modem dongles
 - ordering **51**
- USB serial dongles **20**
 - ordering **51**

V

Vx680

Bluetooth® support **23**

starting on battery power **33**

Vx680 startup

battery mode **33**

W

wireless transactions **41**

VERIFONE
CONFIDENTIAL
DRAFT



V*680 Declaration of Conformity

DECLARATION OF CONFORMITY

according to ISO/IEC Guide 22 and EN 45014

Manufacturer's Name VeriFone, Inc.
Manufacturer's Address VeriFone, Inc.
1400 West Stanford Ranch Road
Suite 200, Rocklin, CA 95765, USA

Declares, that the product

Product Name: V*680
Model Number: M268-XXX-XX-XXX
Product Options: All

Conforms to the following product specifications:

Safety: IEC 60950-1:2005
EN 60950-1:2006+A11:2009
EMC: EN 55022:2006+A1:2007
EN 55024:1998/A1:2001/A2:2003
EN 61000-3-2:2006
EN 61000-3-3:1995+A1:2001+A2:2005
GSM: EN301 489-1 V1.8.1
EN301 489-7 V1.3.1
RFID: EN 301 489-1 V 1.8.1
EN 301 489-3 V 1.4.1 (2002-08)
EN 300 330-1 V 1.5.1 (2006-04)
EN 300 330-2 V 1.3.1 (2006-04)
RF Spectrum Efficiency: EN 301 511, V 9.0.2
SAR: EC Recommendation 1999/519/EC

Supplementary Information:

We hereby declare that the device complies with the requirements of the Low Voltage Directive 2006/95/EC, the EMC Directive 2004/108/EC, R&TTE Directive 1999/5/EC, and carries the CE Mark Directive (93/68/EEC) accordingly.

Dated: October 22, 2009

Fanny Wong
Director of Engineering, Program Management Office
Rocklin, CA, USA



European contact for regulatory topics only:

VeriFone UK Ltd.
Symphony House
7 Cowley Business Park
High Street
Cowley Uxbridge, UB8 2AD
United Kingdom
Tel: +44-1895-275275

FCC Regulations:

●This mobile device complies with part 15 of the FCC Rules. Operation is subject to the following two conditions: (1) This device may not cause harmful interference, and (2) this device must accept any interference received, including interference that may cause undesired operation.

●This mobile device has been tested and found to comply with the limits for a Class B digital device, pursuant to Part 15 of the FCC Rules. These limits are designed to provide reasonable protection against harmful interference in a residential installation. This equipment generates, uses and can radiated radio frequency energy and, if not installed and used in accordance with the instructions, may cause harmful interference to radio communications. However, there is no guarantee that interference will not occur in a particular installation. If this equipment does cause harmful interference to radio or television reception, which can be determined by turning the equipment off and on, the user is encouraged to try to correct the interference by one or more of the following measures:

- Reorient or relocate the receiving antenna.
- Increase the separation between the equipment and receiver.
- Connect the equipment into an outlet on a circuit different from that to which the receiver is connected.
- Consult the dealer or an experienced radio/TV technician for help.

Changes or modifications not expressly approved by the party responsible for compliance could void the user's authority to operate the equipment.

●The antenna(s) used for this transmitter must not be co-located or operating in conjunction with any other antenna or transmitter.

▶ RF Exposure Information (SAR)

This device meets the government's requirements for exposure to radio waves.

This device is designed and manufactured not to exceed the emission limits for exposure to radio frequency (RF) energy set by the Federal Communications Commission of the U.S. Government.

The exposure standard for wireless mobile devices employs a unit of measurement known as the Specific Absorption Rate, or SAR. The SAR limit set by the FCC is 1.6W/kg. *Tests for SAR are conducted using standard operating positions accepted by the FCC with the device transmitting at its highest certified power level in all tested frequency bands. Although the SAR is determined at the highest certified power level, the actual SAR level of the device while operating can be well below the maximum value. This is because the device is designed to operate at multiple power levels so as to use only the power required to reach the network. In general, the closer you are to a wireless base station antenna, the lower the power output.

The highest SAR value for the device as reported to the FCC when tested for use when worn on the body, as described in this user guide, is 0.468 W/kg. (Body-worn measurements differ among device models, depending upon available accessories and FCC requirements.)

While there may be differences between the SAR levels of various devices and at various positions, they all meet the government requirement.

The FCC has granted an Equipment Authorization for this device with all reported SAR levels evaluated as in compliance with the FCC RF exposure guidelines. SAR information on this device is on file with the FCC and can be found under the Display Grant section of www.fcc.gov/oet/ea/fccid/ after searching on FCC ID: B32VX680GPRSC TLS.

This device is compliance with SAR for general population /uncontrolled exposure limits in ANSI/IEEE C95.1-1999 and had been tested in accordance with the measurement methods and procedures specified in OET Bulletin 65 Supplement C.

CE Logo

CE 0678



VeriFone, Inc.
2099 Gateway Place, Suite 600
San Jose, CA, 95110 USA
1-800-VERIFONE
www.verifone.com

VERIFONE
CONFIDENTIAL
DRAFT
REVISION A.3



V^x680

Installation Guide

