

Omni 5xxx and V^x5xx/V^x610

Installation Guide

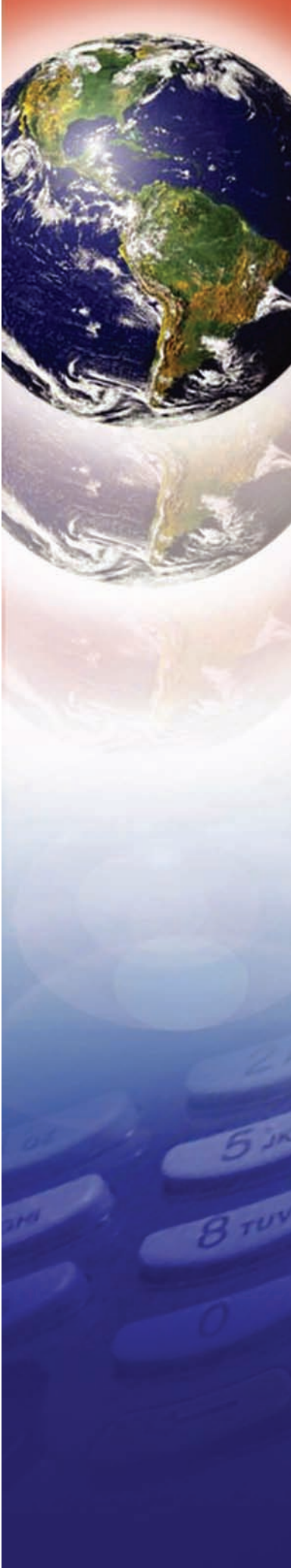

Omni 5xxx and V^x5xx/V^x610 Installation Guide
© 2006 VeriFone, Inc.

All rights reserved. No part of the contents of this document may be reproduced or transmitted in any form without the written permission of VeriFone, Inc.

The information contained in this document is subject to change without notice. Although VeriFone has attempted to ensure the accuracy of the contents of this document, this document may include errors or omissions. The examples and sample programs are for illustration only and may not be suited for your purpose. You should verify the applicability of any example or sample program before placing the software into productive use. This document, including without limitation the examples and software programs, is supplied "As-Is."

VeriFone, the VeriFone logo, Omni, VeriCentre, Verix, and ZonTalk are registered trademarks of VeriFone. Other brand names or trademarks associated with VeriFone's products and services are trademarks of VeriFone, Inc.

All other brand names and trademarks appearing in this manual are the property of their respective holders.

Comments? Please e-mail all comments on this document to your local VeriFone Support Team.

WARNING



Do not dispose of the V^x610 Li-ion smart battery in a fire. Li-ion batteries must be recycled or disposed of properly. Do not dispose of Li-ion batteries in municipal waste sites.



VeriFone, Inc.
2099 Gateway Place, Suite 600
San Jose, CA, 95110 USA

www.verifone.com

VeriFone Part Number 23216, Revision C



CONTENTS

	PREFACE	5
	Audience	5
	Organization	5
	Related Documentation	6
	Conventions and Acronyms	7
	Document Conventions	7
	Acronym Definitions	7
CHAPTER 1		
Terminal Overview	Features and Benefits	10
	Exceptional Ease of Use	10
	Countertop Performance in a “Hand-Over” Design	11
	True Multi-Application Capability	11
	Wireless Connectivity	11
CHAPTER 2		
Terminal Setup	Selecting Terminal Location	13
	Ease of Use	13
	Environmental Factors	13
	Electrical Considerations	14
	Unpacking the Shipping Carton	14
	Examining Terminal Features	15
	Front Panel	15
	Connection Ports	16
	Establishing Telephone Line Connections	18
	Installing the Paper Roll in the Printer	19
	Installing/Replacing MSAM Cards	22
	Connecting Optional Device(s)	24
	V ^x 510 and V ^x 570 Optional Device Connections	24
	V ^x 610 Optional Device Connections	26
	External Printers Supported	27
	Connecting the Terminal Power Pack	28
	V ^x 610 Battery Behavior (No Power Cord)	30
	Manual Startup	30
	Manual Shutdown	30
	Installing the Privacy Shield	31
	V ^x 510/V ^x 610 Privacy Shield	31
	V ^x 570 Privacy Shield	32
	Installing the V ^x 610 Smart Battery	33
	Installation	33
	Removal	34
	Charging	34
	Battery Life	34
	Using the V ^x 610 Spare Battery Charger	35
	Using the V ^x 610 Power Cradle	36

	Install/Replace SIM Card (GSM/GPRS Models)	37
	Connecting the V ^x 610 External Antenna	40
	Installation	40
	Orientation	41
	Replacing the Antenna	41
	Conducting Wireless Transactions	42
	Using the Smart Card Reader	42
	Using the Magnetic Card Reader	42
CHAPTER 3		
Specifications	Power	45
	DC Power Pack	45
	Temperature	45
	External Dimensions	45
	SAR Compliance	46
	CDMA	46
	GSM/GPRS	46
CHAPTER 4		
Maintenance	Clean the Terminal	47
	Terminal Contacts	47
	Smart Card Reader	47
CHAPTER 5		
VeriFone Service and Support	Return a Terminal or Smart Battery for Service	49
	Accessories and Documentation	50
	Power Pack	50
	Thermal Printer Paper	50
	VeriFone Cleaning Kit	51
	Telephone Line Cord	51
	Swivel Stand	51
	Documentation	51
CHAPTER 6		
Troubleshooting Guidelines	Blank Display	53
	Terminal Does Not Dial Out	53
	Printer Paper Jam	54
	Keypad Does Not Respond	54
	Peripheral Device Does Not Work	54
	Transactions Fail To Process	54
	Printer Does Not Print	55
	Terminal Display Does not Show Correct/Readable Information	56
	V ^x 610 Terminal Does Not Start	56
	V ^x 610 Smart Battery Will Not Charge	56
	Printer Does Not Print	56
	INDEX	57



This guide is your primary source of information for setting up and installing the V^x5xx/V^x610 terminal.

NOTE



In this document, V^x5xx/V^x610 refers to the series of VeriFone terminals, including the V^x510 (Omni 5100/5150), V^x570 (Omni 5700/5750), and V^x610 (Omni 5600).

Audience

This guide is useful for anyone installing and configuring a V^x5xx/V^x610 terminal. Basic descriptions of the terminal features are also provided.

Organization

This guide is organized as follows:

Chapter 1, Terminal Overview. Provides an overview of the V^x5xx/V^x610 series of terminals.

Chapter 2, Terminal Setup. Explains how to set up and install the V^x5xx/V^x610 terminal. It tells you how to select a location, establish power and telephone line connections, and how to configure optional peripheral devices.

Chapter 3, Specifications. Discusses power requirements and dimensions of the V^x5xx/V^x610 terminal.

Chapter 4, Maintenance. Explains how to maintain your V^x5xx/V^x610 terminal.

Chapter 5, VeriFone Service and Support. Provides information on contacting your local VeriFone representative or service provider, and information on how to order accessories or documentation from VeriFone.

Chapter 6, Troubleshooting Guidelines. Provides troubleshooting guidelines, should you encounter a problem in terminal installation and configuration.

Related Documentation

To learn more about the V^x5xx/V^x610 series of terminals, refer to the following set of documents:

For V^x510:

Omni 5100/5150 and V ^x 510, Omni 3730 Certifications and Regulations	VPN 23218
Omni 5100/5150 and V ^x 510 Quick Installation Guide	VPN 23219
Omni 5100/5150 and V ^x 510 with Ethernet Quick Installation Guide	VPN 23268
Omni 37xx/5xxx and V ^x 5xx Stacker Quick Installation Guide	VPN 23784
Omni 51xx and V ^x 5xx Swivel Stand Quick Installation Guide	VPN 23043

For V^x570:

Omni 5700/5750 and V ^x 570 Certifications and Regulations	VPN 23646
Omni 57xx and V ^x 570 Quick Installation Guide	VPN 23759
Omni 57xx and V ^x 570 Large Paper Door Quick Installation Guide	VPN 24126
Omni 57xx and V ^x 570 Privacy Shield Quick Installation Guide	VPN 24134

For V^x610:

Omni 56xx and V ^x 610 Carrying Case Quick Installation Guide	VPN 23640
Omni 56xx and V ^x 610 Attachable Strap/Handstrap Quick Installation Guide	VPN 23641
Omni 56xx and V ^x 610 Quick Installation Guide	VPN 23643
Omni 56xx and V ^x 610 Certifications and Regulations	VPN 23644
Omni 56xx and V ^x 610 Spare Battery Charger Quick Installation Guide	VPN 23645
Omni 56xx and V ^x 610 Power Cradle Quick Installation Guide	VPN 24125

For V^x510 and V^x610:

Omni 5xxx and V ^x 510/V ^x 610 Privacy Shield Quick Installation Guide	VPN 23642
---	-----------



Conventions and Acronyms

This section describes the conventions and acronyms used in this guide.

Document Conventions

Various conventions are used to help you quickly identify special formatting. [Table 1](#) describes these conventions and provides examples of their use.

Table 1 Document Conventions

Convention		
Blue	Text in blue indicates terms that are cross referenced.	See Conventions and Acronyms .
<i>Italics</i>	Italic typeface indicates book titles or emphasis.	You <i>must</i> install a roll of thermal-sensitive paper in the printer.
Courier	The courier type face is used while specifying onscreen text, such as text that you would enter at a command prompt, or to provide an URL.	<code>http://www.verifone.com</code>
	The pencil icon is used to highlight important information.	RS-232-type devices do not work with the PINpad port.
	The caution symbol indicates possible hardware or software failure, or loss of data.	The terminal is not waterproof or dustproof, and is intended for indoor use only.
	The lightning symbol is used as a warning when bodily injury might occur.	Due to risk of shock do not use the terminal near water.

Acronym Definitions

Various acronyms are used in place of the full definition. [Table 2](#) presents acronyms and their definitions.

Table 2 Acronym Definitions

Acronym	Definitions
AC	Alternating Current
ATM	Automated Teller Machine
CDMA	Code Division Multiple Access
CR	Check Reader
EMV	Europay MasterCard and VISA
GPRS	General Packet Radio Service
GSM	Global System for Mobile Communication
ITP	Internal Thermal Printer
LCD	Liquid Crystal Display

Table 2 **Acronym Definitions** (continued)

Acronym	Definitions
LED	Light Emitting Diode
MRA	Merchandise Return Authorization
MSAM	Micromodule-Size Security Access Module
PED	PIN-Entry Devices
PIN	Personal Identification Number
RJ45	Registered Jack 45
RS-232	Recommended Standard 232
SAM	Security Access Module
VPN	VeriFone Part Number
Wi-Fi	Wireless Fidelity



Terminal Overview

This chapter provides a brief description of the V^x5xx/V^x610 series of terminals. The V^x5xx/V^x610 terminal series represents the shape of things to come in e-payment. These terminals are members of a broad product family that will provide a clear migration path into the future for current users of Omni countertop and portable terminals.

- The V^x510 is a high performance countertop terminal with fixed enhanced communication options. The V^x510 (also referred to as Omni 5100/5150) is the entry-point countertop terminal.
- The V^x610 represents a new generation of wireless terminals. The pioneering V^x610 (also known as Omni 5600) features the same sleek, compact design of the V^x510, but in a portable, battery-powered form factor that uses wireless technologies, including Wi-Fi, CDMA and GSM/GPRS.
- The V^x570 (also known as Omni 5700/5750) is a high performance countertop terminals with modular communication options, enhanced display, expanded memory options, and a USB peripheral port.

V^x510 and V^x610 terminals use a bold ergonomic design that is sleek and stylish, offering countertop power and 32-bit performance in an integrated terminal that can be handed to the consumer for input. The V^x570 design continues the success of the Omni 37xx design.

The V^x510 and V^x610 serve as the entry point to VeriFone's acclaimed multi-application platform—with the capability to securely support payment and value-added applications on a single terminal—while the V^x570 is perfect for those customers who need more.



VeriFone ships variants of the V^x5xx/V^x610 terminals for different markets. Your terminal may have a different configuration. The following devices may or may not be present: a smart card reader, or zero or three MSAM cardholders.



Features at a Glance

- Delivers **power** and **usability** in a **convenient** “hand-over” design.
- **Multi-application** operating environment.
- **32-bit processing** and **multi-tasking** capabilities.
- Securely supports and runs **payment** and **value-added applications**.
- Offers **unsurpassed performance** on **EMV** smart card transactions.
- **Security** architecture meets specifications for PED and sophisticated **file authentication**.

Features and Benefits

V^x5xx/V^x610 terminals provide the right combination of features and functions. This includes a triple-track magnetic-stripe card reader, smart card reader, integrated PINpad, and a quiet yet fast internal thermal printer (ITP).

Exceptional Ease of Use

- The bold design is sleek, stylish, and lightweight for conveniently handing the terminal to the consumer for PIN entry or other input.
- An intuitive ATM-style interface, a large 8-line x 21-character backlit display with split-screen capabilities, large keys, and extra-size menu prompts simplify training and reduce help desk calls.
- The integrated high-speed thermal printer simplifies paper loading and virtually eliminates paper jams.
- The triple-track, high-coercivity card reader handles most magnetic stripe cards.

Countertop Performance in a “Hand-Over” Design

- The 32-bit processing and multi-tasking capabilities make short work of payment, payment-related, and value-added applications.
- The V^x5xx/V^x610 series of terminals has exceptional display and printer graphics-handling capabilities that quickly render logos, graphical fonts, and character-based languages.
- The VeriCentre Appliance Management Suite employs advanced file compression to streamline simultaneous downloads of application software to hundreds of terminals.
- The integrated PINpad offers added convenience to handle PIN-based applications.
- The V^x5xx/V^x610 series of terminals ensures uncompromising reliability from VeriFone, the worldwide leader in e-payment.

True Multi-Application Capability

- V^x510 and V^x610 terminals offer 3 MB or 6 MB of memory and the dynamic memory allocation of the Verix V OS, support two or three typical-sized applications on a single terminal. The V^x570 offers 6 MB and 12 MB memory options.
- The primary smart card reader and the MSAMs safeguard sensitive financial data and support multiple smart card schemes.
- The V^x5xx/V^x610 series of terminals and SoftPay EMV software have received EMV Level 1 and Level 2 Type approval for smart card solutions. The Verix EMV Library provides efficient development of other EMV-compliant applications.
- The VeriShield security architecture meets published specifications for PED and provides sophisticated file authentication to prevent execution of unauthorized software on V^x5xx/V^x610 terminals.

Wireless Connectivity

- With the V^x610 wireless terminals, the point of payment can be almost anywhere. Customers are not tied to a fixed location.
- “Always on” wireless connection is made using the latest wireless technologies, including GSM/GPRS, CDMA and Wi-Fi. The V^x570 also offers an additional ISDN (Integrated Services Digital Network) communications option.



Terminal Setup

This chapter describes the terminal setup procedure. You will learn about:

- Selecting Terminal Location.
- Unpacking the Shipping Carton.
- Examining Terminal Features.
- Establishing Telephone Line Connections.
- Installing the Paper Roll in the Printer.
- Installing/Replacing MSAM Cards.
- Connecting Optional Device(s).
- Connecting the Terminal Power Pack.
- Installing the Privacy Shield.
- Installing the V^x610 Smart Battery.
- Using the V^x610 Spare Battery Charger.
- Using the V^x610 Power Cradle.
- Installing/Replacing the SIM Card (GSM/GPRS Models).
- Connecting the V^x610 External Antenna.
- Conducting Wireless Transactions.
- Using the Smart Card Reader.
- Using the Magnetic Card Reader.

Selecting Terminal Location

Use the following guidelines when selecting a location for your V^x5xx/V^x610 terminal.

Ease of Use

- Select a location convenient for both merchant and cardholder.
- Select a flat support surface, such as a countertop or table.
- Select a location near a power outlet and a telephone/modem line connection. For safety, do not string the power cord in a walkway or place it across a walkway on the floor.

Environmental Factors

- Do not use the terminal where there is high heat, dust, humidity, moisture, or caustic chemicals or oils.

- Keep the terminal away from direct sunlight and anything that radiates heat, such as a stove or motor.
- Do not use the terminal outdoors.

CAUTION

The terminal is not waterproof or dustproof, and is intended for indoor use only. Any damage to the unit from exposure to rain or dust may void any warranty.

Electrical Considerations

- Avoid using this product during electrical storms.
- Avoid locations near electrical appliances or other devices that cause excessive voltage fluctuations or emit electrical noise (for example, air conditioners, electric motors, neon signs, high-frequency or magnetic security devices, or computer equipment).
- Do not use the terminal near water or in moist conditions.

Unpacking the Shipping Carton

Open the shipping carton and carefully inspect its contents for possible tampering or shipping damage. The V^x5xx/V^x610 terminal is a secure product and any tampering may cause the device to cease to function properly.

To unpack the Shipping Carton

- 1 Remove and inspect the following items:
 - Terminal
 - Power pack
 - Telephone line cord
 - Power cord
 - Battery pack (for V^x610 only)
 - Antenna (for V^x610 only, if shipped loose)
 - Paper roll
- 2 Remove all plastic wrapping from the terminal and other components.
- 3 Remove the clear protective film from the LCD screen.

CAUTION

Do not use a terminal that has been damaged or tampered with. The V^x5xx/V^x610 terminal comes equipped with tamper-evident labels. If a label or component appears damaged, please notify the shipping company and your VeriFone representative or service provider immediately.

- 4 Save the shipping carton and packing material for future repacking or moving the terminal.

Examining Terminal Features

Before you continue the installation process, notice the features of the V^x5xx/V^x610 terminal (see Figure 1).

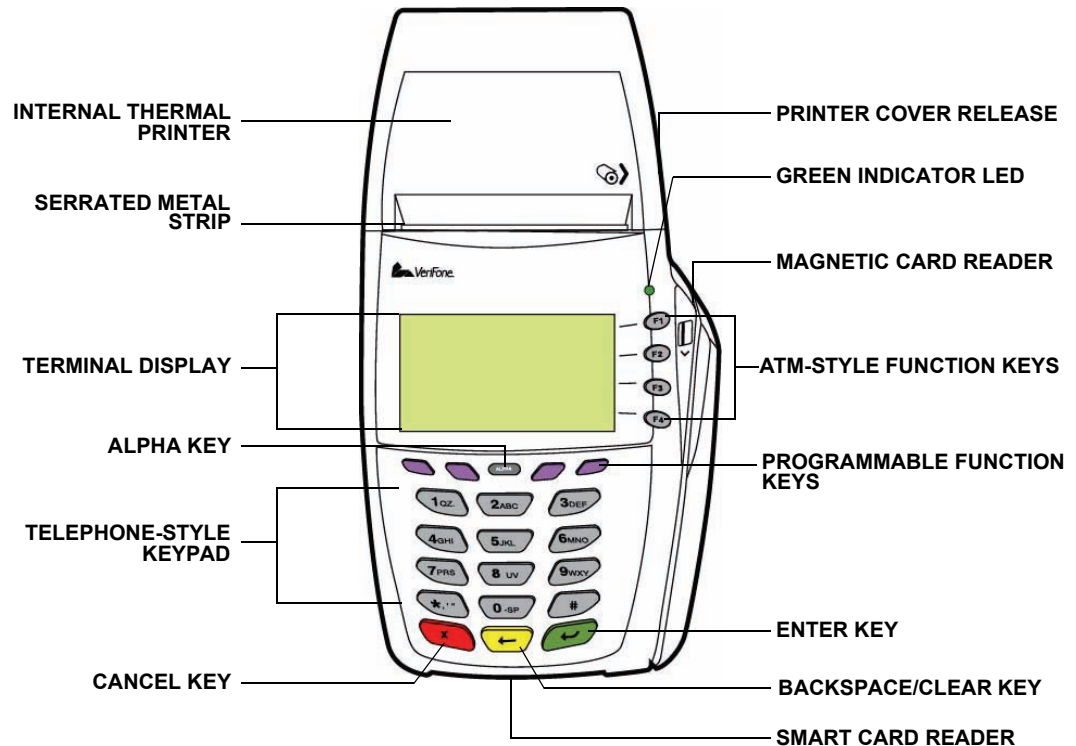





Figure 1 V^x5xx/V^x610 Terminal Features (Front Panel)

Front Panel The front panel includes the following features:

- A **terminal display**, backlit LCD screen.
- Five types of keys:
 - A 12-key, **telephone-style keypad**.
 - Four **ATM-style function keys**, labeled F1 to F4, to the right of the LCD screen.
 - Four unlabeled, **programmable function keys** above the keypad.
 - Three **color-coded function keys** below the keypad (icons at right; from left to right: CANCEL, BACKSPACE/CLEAR, ENTER).
 
 - An **ALPHA key** centered at the top of the keypad.
- A **magnetic card reader**, built into the right side. The icon at right shows the proper swipe direction, with the stripe down and facing inward, toward the keypad.
 
- A green **indicator LED** indicates power is ON.
- An **internal thermal printer**.

- A **smart card reader**, built into the front of the terminal. The icon shown at right indicates proper card position and insertion direction. 
- A **SAM (security access module) compartment**, built into the bottom of the terminal. The V^x5xx/V^x610 terminal contains MSAM cardholders to support multiple stored-value card programs or other merchant card requirements.

NOTE



VeriFone ships variants of the V^x5xx/V^x610 terminal for different markets. Your terminal may have a different configuration. The following devices may or may not be present: a smart card reader, or zero or three MSAM cardholders. However, the basic processes described in this guide remain the same, regardless of terminal configuration.

Connection Ports Turn the terminal upside down to view the connection ports. Notice that the ports are recessed. Different ports are provided to connect the terminal to a communications line, optional peripheral devices, and the power supply.

Figure 2 shows the connection ports for the V^x510 terminal.

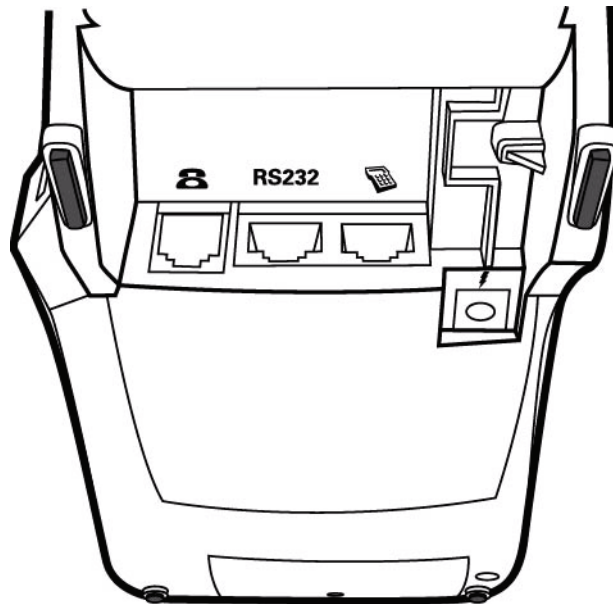

Figure 2 V^x510 Connection Ports (Bottom View)

Figure 3 shows the connection port for the V^x570 terminal.

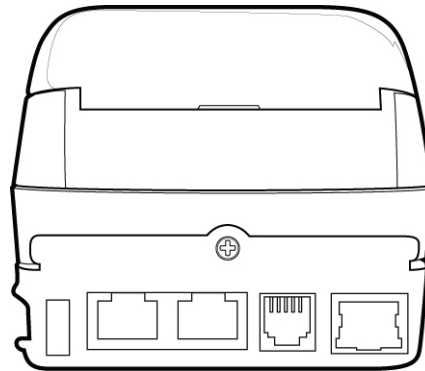

Figure 3 V^x570 Connection Ports (Back View)

Figure 4 shows the connection ports for the V^x610 terminal.

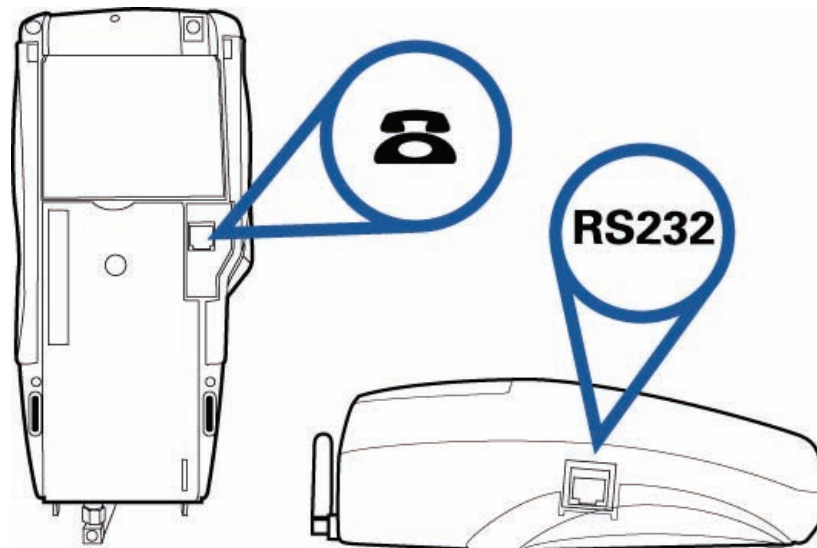

Figure 4 V^x610 Connection Ports (Bottom and Side Views)



WARNING Do not connect the terminal to the power supply until all the peripherals are attached.

For information on how to attach peripheral devices, see [Connecting Optional Device\(s\)](#).

Establishing Telephone Line Connections

Connect the telephone cord to the communication port on the terminal, then route it directly to a telephone wall jack (see Figure 5, Figure 6, and Figure 7). This is a direct connection and the line is dedicated to the terminal.

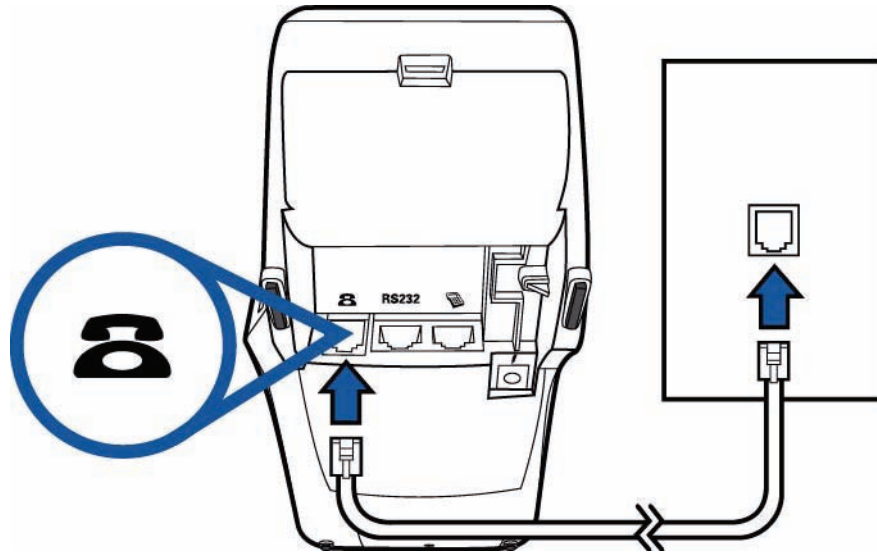

Figure 5 VX510 Direct Telephone Connection

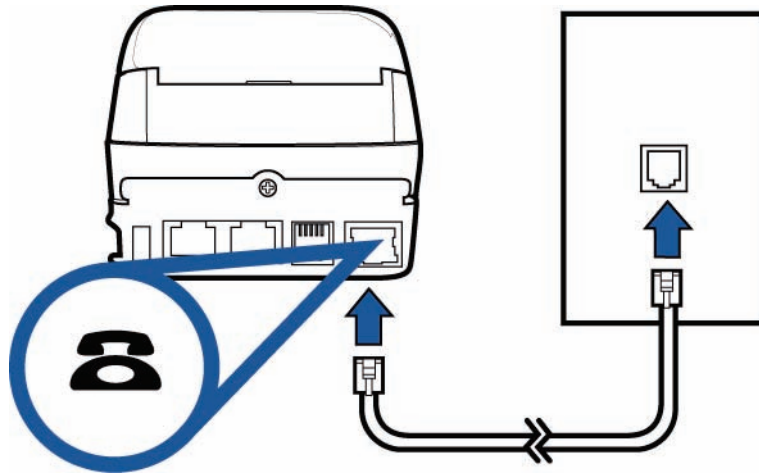

Figure 6 VX570 Direct Telephone Connection

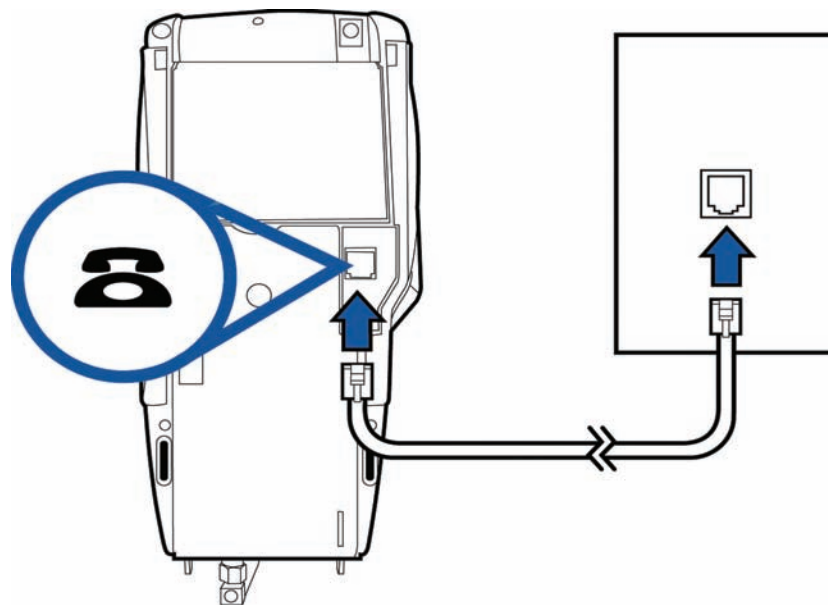

Figure 7 Vx610 Direct Telephone Connection



WARNING To reduce the risk of fire, use only No. 26AWG or larger UL Listed or CSA Certified Telecommunication Line Cord.

Installing the Paper Roll in the Printer

A fast, quiet thermal printer is built into the Vx5xx/Vx610 terminal. Before you can process transactions that require a receipt or record, you *must* install a roll of thermal-sensitive paper in the printer.

NOTE



Vx610 print speed varies depending on battery charge.

The ITP uses a roll of single-ply, thermal-sensitive paper 57 millimeters (2.24 inches) wide and 25 meters (82 feet) long. A pink *out-of-paper* indicator line appears on the edge of the paper approximately 18 inches before the end of the roll. After this line appears, there is enough paper remaining on the roll to conclude at least one transaction.



CAUTION Poor-quality paper can jam the printer and create excessive paper dust. To order high-quality VeriFone paper, refer to [Accessories and Documentation](#).

Store thermal paper in a dry, dark area. Handle thermal paper carefully: impact, friction, temperature, humidity, and oils affect the color and storage characteristics of the paper.

Never load a roll of paper with folds, wrinkles, tears, or holes at the edges.

- To Install a Paper Roll** 1 Press down on the button located on the side of the terminal to unlatch the paper roll cover, then lift the cover up and back (see Figure 8).

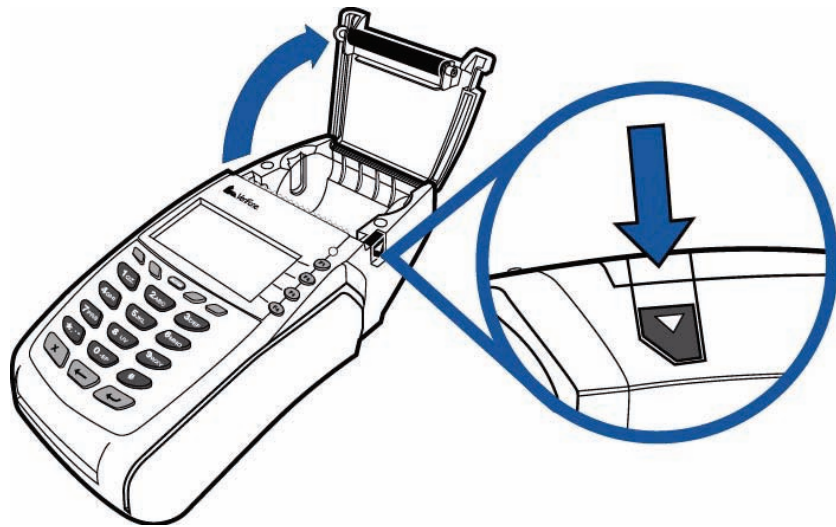

Figure 8 Opening the Printer Cover

- 2 Remove any partial roll of paper in the printer tray by lifting up (see Figure 9).
 3 Loosen the glued leading edge of the paper or remove the protective strip from the new roll of paper. Unwind the paper roll past any glue residue.



Figure 9 Removing Partial Paper Roll

- 4 Hold the roll so the paper feeds from the *bottom* of the roll (see Figure 10).

- 5 Drop the paper roll into the printer tray.

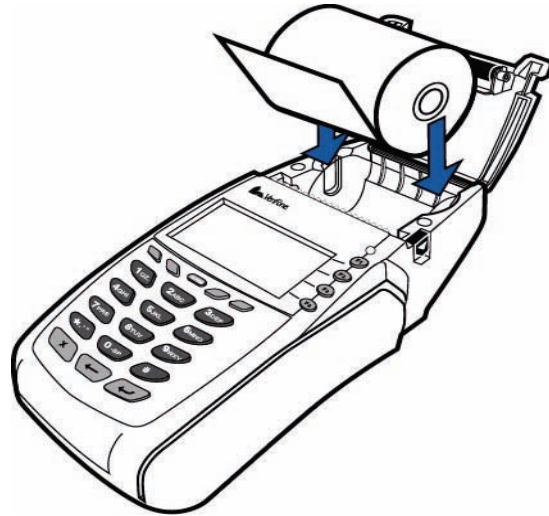

Figure 10 Loading Paper Roll

- 6 Pull paper up past the glue residue.
- 7 Close the paper roll cover by gently pressing directly on the cover until it clicks shut, allowing a small amount of paper past the glue residue to extend outside the printer door. (see [Figure 11](#)).



To prevent the paper roll cover from damaging the print roller, always gently press down on the printer dust cover to close it.



Figure 11 Closing Paper Roll Cover

- 8 Tear the paper off against the serrated metal strip in the printer.

For paper ordering information, refer to [Accessories and Documentation](#).

Installing/ Replacing MSAM Cards

When you first receive your V^x5xx/V^x610 terminal, you may need to install one or more MSAM cards or you may need to replace old cards.



CAUTION Observe standard precautions when handling electrostatically sensitive devices. Electrostatic discharges can damage this equipment. VeriFone recommends using a grounded anti-static wrist strap.

To Install/Replace MSAMs

- 1 Remove the power cord and/or battery (see [Installing the V^x610 Smart Battery](#)) from the terminal.
- 2 Place the terminal upside down on a soft, clean surface to protect the lens from scratches.
- 3 Remove the MSAM compartment door screw and rotate the door up and back to access the MSAM cardholders (see [Figure 12](#)).

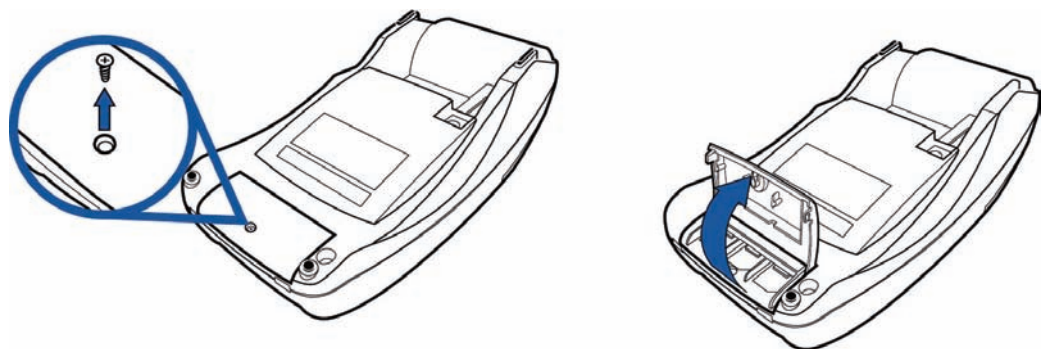

Figure 12 Opening V^x510 MSAM Compartment Door

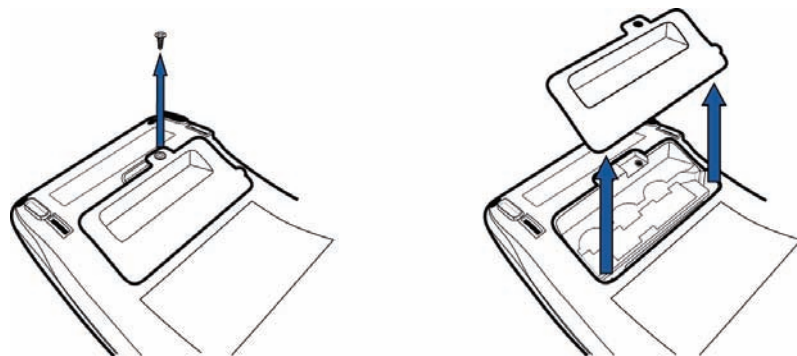

Figure 13 Opening V^x570 MSAM Compartment Door

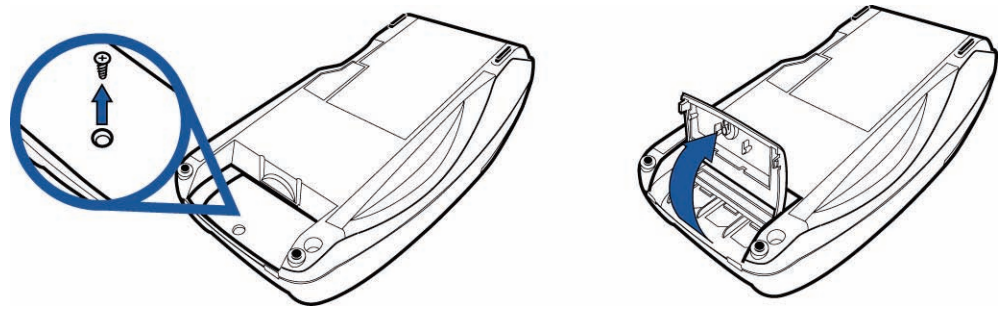

Figure 14 Opening V^x610 MSAM Compartment Door

- 4 Remove any previously installed MSAM card by sliding the card from the MSAM cardholder.
- 5 Install an MSAM card by aligning the card and carefully sliding it within the guides on the cover until it is fully inserted (see [Figure 15](#)).

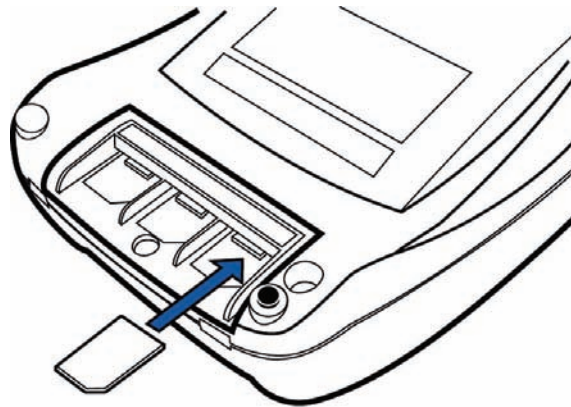

Figure 15 Installing an MSAM Card

NOTE



Before inserting the MSAM card, position it as shown in [Figure 15](#), with the card's gold contacts facing the smart car reader end of the terminal. The cardholder connector base has a set of contacts and a notch on one corner to ensure the MSAM card is positioned correctly. The MSAM card has a notch on one corner to ensure that it fits into the connector base in only one way. The MSAM compartment door will not close properly if the MSAM cards are installed incorrectly.

- 6 Replace the MSAM compartment door and reinstall the screw.

Connecting Optional Device(s)

The V^x5xx/V^x610 series of terminals supports some peripheral devices designed for use with electronic point-of-sale terminals.

CAUTION

Before connecting any peripheral device, remove the power cord and/or battery (see [Installing the V^x610 Smart Battery](#)) from the terminal and ensure that the green indicator LED is not lit. Reconnect the power cord and/or battery only *after* you are finished connecting the peripheral device(s). For complete information about peripheral installation and use, refer to the user documentation supplied with those devices.

Different terminals support different devices, so for more information about optional devices, please contact your VeriFone distributor.

NOTE

RS-232-type devices do not work on the PINpad port. PINpad-type devices do not work on the RS-232 port. If an optional peripheral device does not function correctly, check the port connection.

V^x510 and V^x570 Optional Device Connections

For the V^x510 and V^x570, use the two ports on the back panel to connect up to two optional devices.

Connecting the PINpad or Smart Card Reader to the V^x510 or V^x570

Use the following procedure to connect a PINpad or smart card reader.

- 1 Insert the RJ45-type connector on the end of the PINpad or smart card reader into the port on the back of the peripheral device.

To install a PINpad 101, PINpad 201, or PINpad 1000, position and insert the grommet to secure the cable connection.

If a cable is not already connected to the smart card reader or PINpad, insert the small modular plug on one end of the interface cable into the optional device's modular jack.

- 2 Insert the larger RJ45-type connector on the other end of the PINpad cable into the PINpad serial port on the bottom of the terminal.

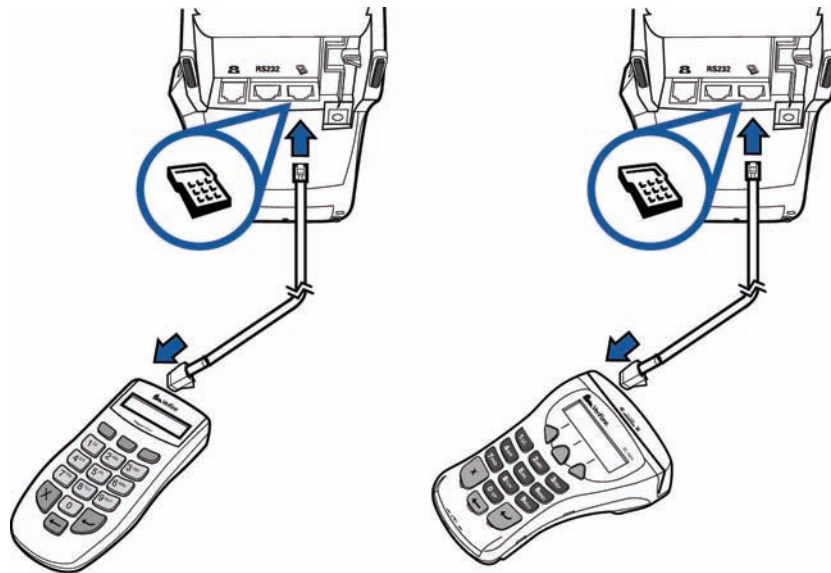

Figure 16 V^x510 Example PINpad Serial Port Connections

Connecting the Check Reader to the V^x510 or V^x570

The V^x5xx terminal supports the CR 600 and CR 1000i check readers. Contact your VeriFone representative or visit the online store at www.store.verifone.com for information on these devices. Figure 17 provides an example of a peripheral connection to the RS-232 port.



Check readers require a separate power source. Before connecting a check reader or similar device, remove the power cord and/or battery (see [Installing the V^x610 Smart Battery](#)) from the bottom of the terminal and ensure that the green indicator LED is not lit.

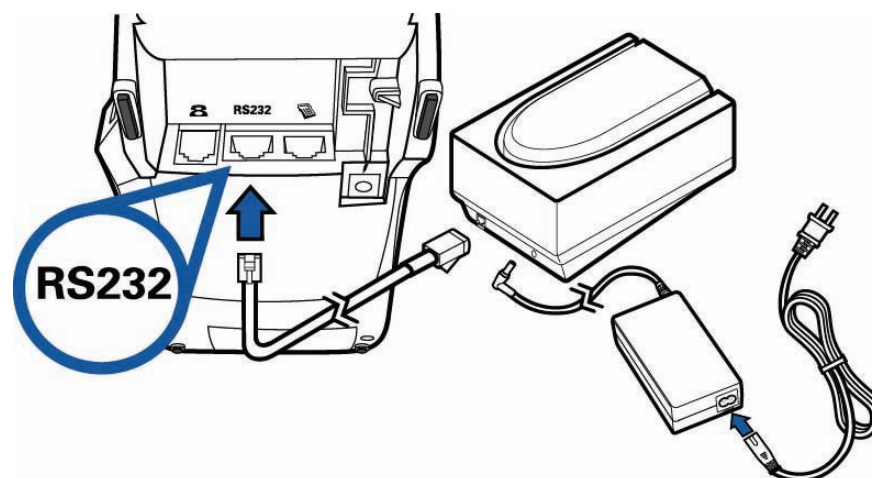

Figure 17 V^x510 Example Check Reader Connection

V^x610 Optional Device Connections

The side port of the V^x610 terminal can operate either as a PINpad port or an RS-232 port, depending on the power source available.

Connecting the PINpad or Smart Card Reader to the V^x610

Use the following procedure to connect a PINpad or smart card reader.



NOTE When the V^x610 terminal is powered via the corded power supply, the terminal provides 400 mA at 9V DC to the side port. This power will drive most VeriFone accessories. Contact your local VeriFone representative for more information.

- 1 Insert the RJ45-type connector on the end of the PINpad or smart card reader into the port on back of the peripheral device.

To install a PINpad 101, PINpad 201, or PINpad 1000, position and insert the grommet to secure the cable connection.

If a cable is not already connected to the smart card reader or PINpad, insert the small modular plug on one end of the interface cable into the optional device's modular jack.

- 2 Insert the larger RJ45-type connector on the other end of the PINpad cable into the PINpad serial port on the side of the terminal. [Figure 18](#) provides an example of a smart card reader and PINpad connection to the PINpad serial port.

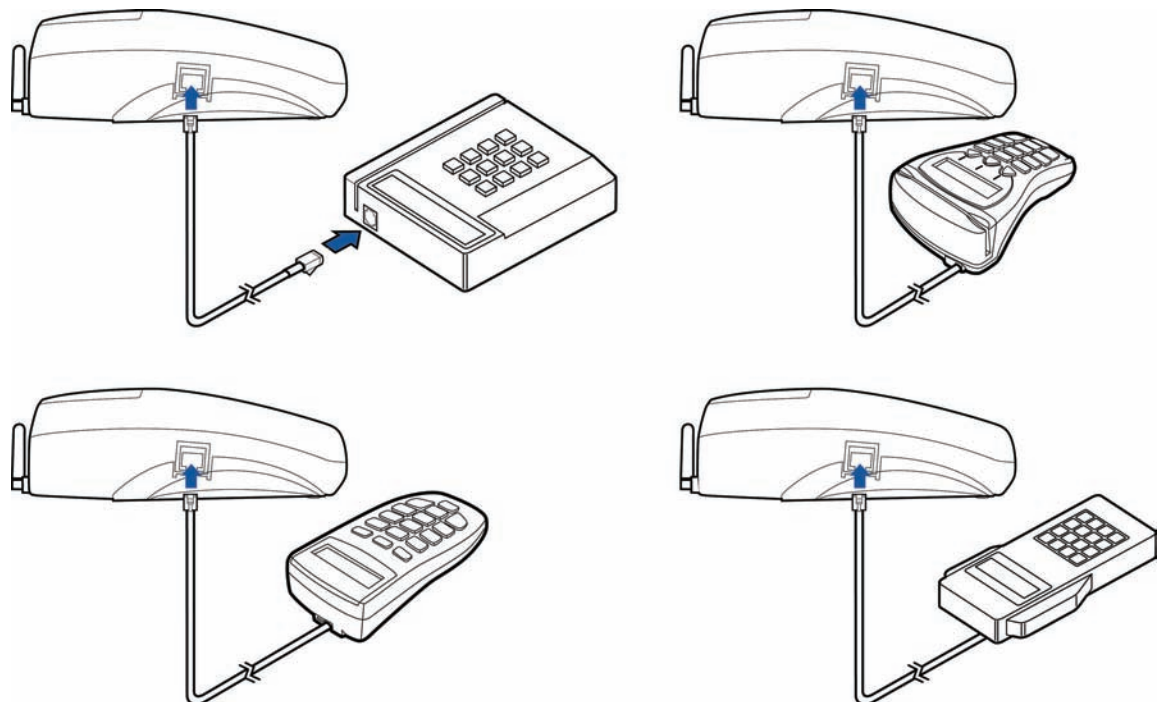

Figure 18 V^x610 Example PINpad Serial Port Connections

Connecting the Check Reader to the V^x610

The V^x610 terminal also supports the CR 600 and CR 1000*i* check readers. Contact your VeriFone representative or visit the online store at www.store.verifone.com for information on these devices.

Figure 19 provides an example of a peripheral connection to the RS-232 port.



CAUTION Check readers require a separate power source. Before connecting a check reader or similar device, remove the power cord and/or battery (see [Installing the V^x610 Smart Battery](#)) from the bottom of the terminal and ensure that the green indicator LED is not lit.

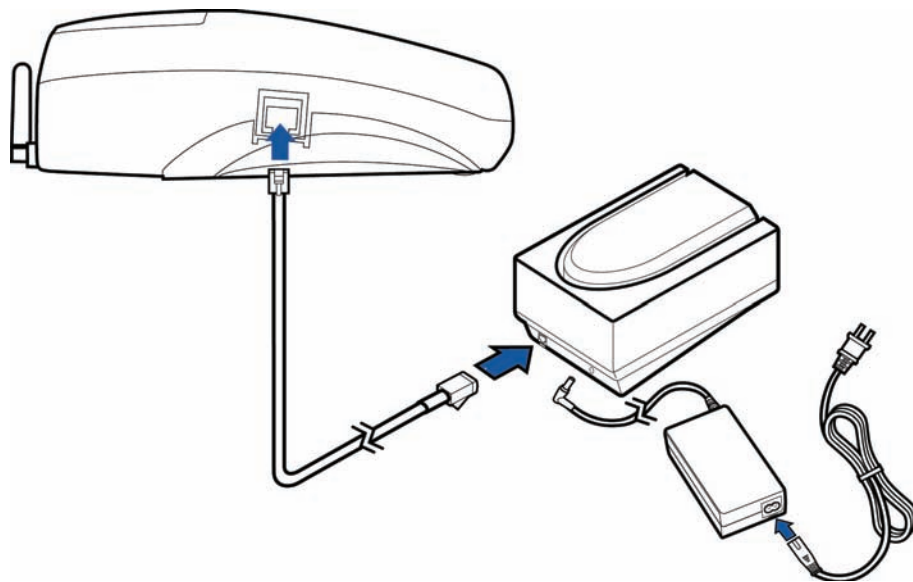

Figure 19 V^x610 Example Check Reader Connection

External Printers Supported

Although all V^x5xx/V^x610 variants have an internal thermal printer, it may be convenient to print larger print runs (for example, daily or weekly reports) to an external printer. The V^x5xx/V^x610 terminal supports the VeriFone P250, P350, P900, and P950 external printers. Contact your VeriFone representative or visit the online store at www.store.verifone.com for information on these devices. External printers connect through the RS-232 port and require a separate power supply.

Connecting the Terminal Power Pack

When you have finished connecting optional peripheral(s), you are ready to connect the V^x5xx/V^x610 terminal to the provided power source.

CAUTION



Using an incorrectly rated power supply may damage the terminal or cause it not to work as specified. Before troubleshooting, ensure that the power supply being used to power the terminal matches the requirements specified on the bottom of the terminal. (See [Chapter 3, Specifications](#), for detailed power supply specifications.) Obtain the appropriately rated power supply before continuing with troubleshooting.

NOTE



Plugging in the power pack to a power source automatically turns on the terminal.

To Connect the Terminal Power Pack

- 1 Insert the round barrel connector (see [Figure 20](#), [Figure 21](#) and [Figure 22](#)) into the power port, identified by the icon at right.

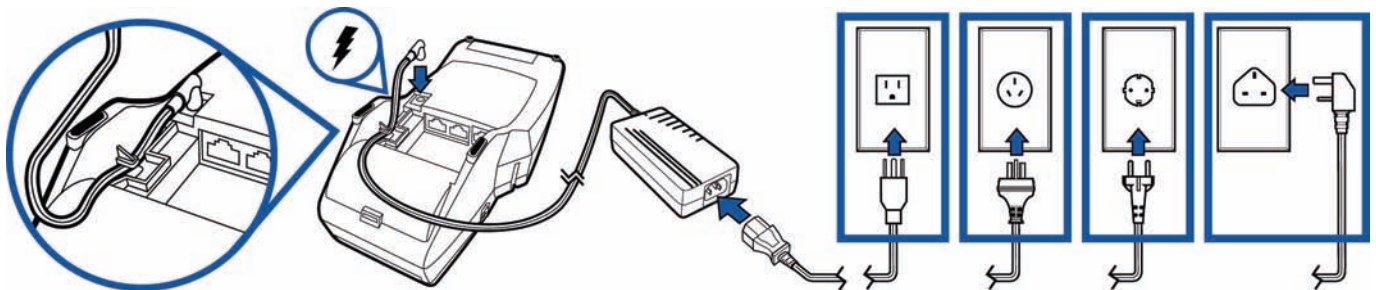

Figure 20 V^x510 Power Pack Connection

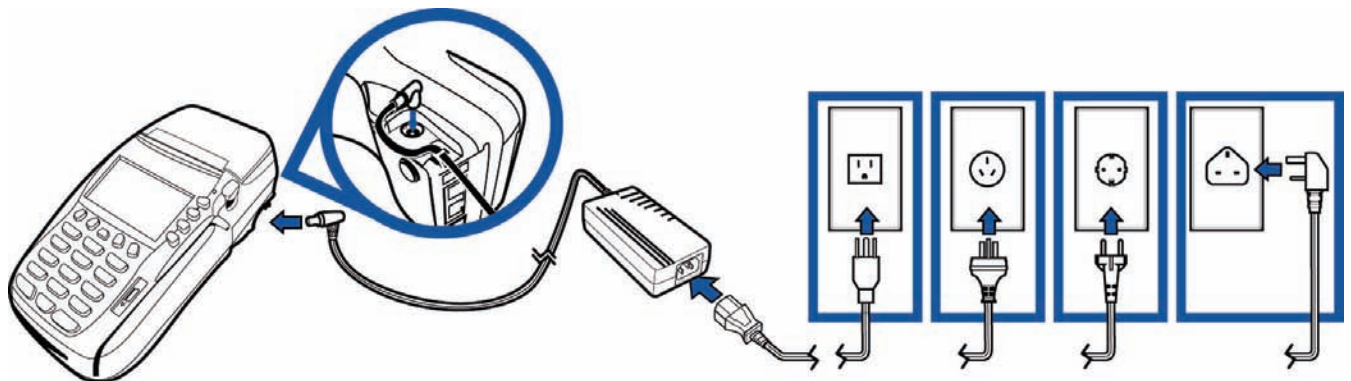

Figure 21 V^x570 Power Pack Connection

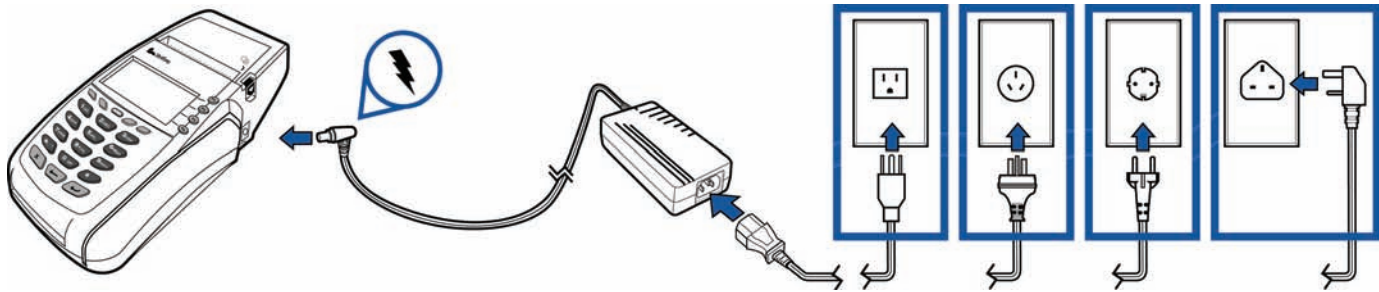

Figure 22 Vx610 Power Pack Connection

- 1 Route the cable through cable retainer where provided to secure the power cord.

NOTE



The bottom of the Vx510 and Vx570 terminals have an integrated cable-retaining feature to secure the power cord to the terminal. The battery-based Vx610 does not need this feature.

- 2 Insert the AC power cord into the power pack.
- 3 Plug the AC power cord into a wall outlet or powered surge protector.

WARNING



Do not plug the power pack into an outdoor outlet or operate the terminal outdoors.

Disconnecting the power during a transaction may cause transaction data files not yet stored in terminal memory to be lost.

To protect against possible damage caused by lightning strikes and electrical surges, consider installing a power surge protector.

NOTE



VeriFone recommends connecting wall power in the following order:

- 1 First, connect the terminal to the power supply.
- 2 Next, connect the power supply to the power cord.
- 3 And last, connect the power cord to the wall outlet.

When the terminal has power, the terminal lights are activated and the green LED indicator remains lit.

If an application is loaded in the terminal, it starts after the initial VeriFone copyright screen and usually displays a unique copyright screen. If no application is loaded in the terminal, **DOWNLOAD NEEDED** appears on screen after the initial VeriFone copyright screen.

V^x610 Battery Behavior (No Power Cord)

When you have finished connecting optional peripheral(s), you are ready to power the V^x610 terminal from the attached battery.

NOTE



If you connect the V^x610 to a non-battery power source, the terminal shifts to corded power mode and starts up automatically, regardless of the battery charge state.

Manual Startup

Hold the green key down through a series of short beeps until the terminal displays the startup screen.

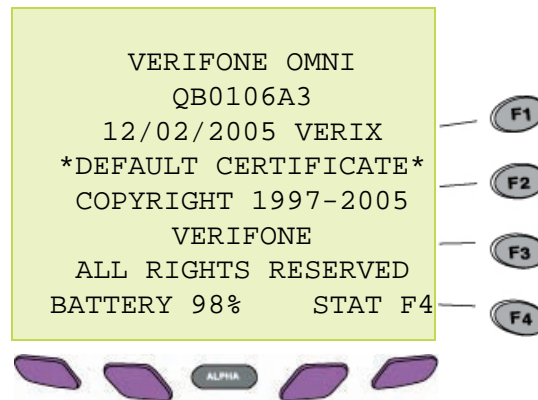

Figure 23 V^x610 Startup Screen

When the terminal has power, the terminal lights are activated and the green LED indicator remains lit.

NOTE



If an application is loaded in the terminal, it starts after the initial VeriFone copyright screen and usually displays a unique copyright screen. If no application is loaded in the terminal, **DOWNLOAD NEEDED** appears on screen after the initial VeriFone copyright screen.

Manual Shutdown

Hold the red key down through a series of short beeps until the terminal displays the shutdown verification screen. Keep holding the red key until the V^x610 terminal shuts down.

NOTE



When the terminal has no power, the screen is blank and the green LED indicator is not lit.

Installing the Privacy Shield

The privacy shield protects the customers' PIN entry from being seen by the cashier or other customers.

V^x510/V^x610 Privacy Shield

To install the V^x510/V^x610 privacy shield:

- 1 Align the privacy shield with the V^x510/V^x610 terminal and carefully insert the shield. Make sure that the privacy shield window clears all keys.

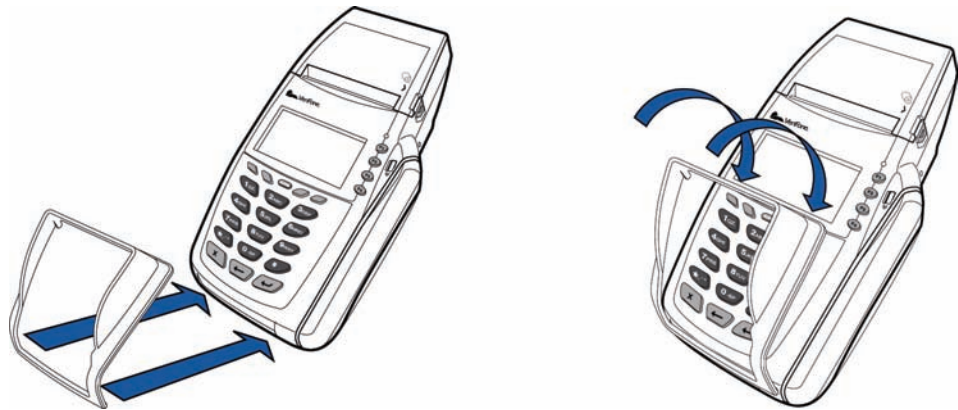

Figure 24 Insert the V^x510/V^x610 privacy shield

- 2 Press firmly on all edges around the privacy shield to ensure it is correctly seated.



Figure 25 Make sure that the privacy shield is properly seated

V^x570 Privacy Shield

To install the V^x570 privacy shield:

- 1 Remove the sticker (identified by the magnetic card reader icon) located on the right hand side of the telephone-style keypad.

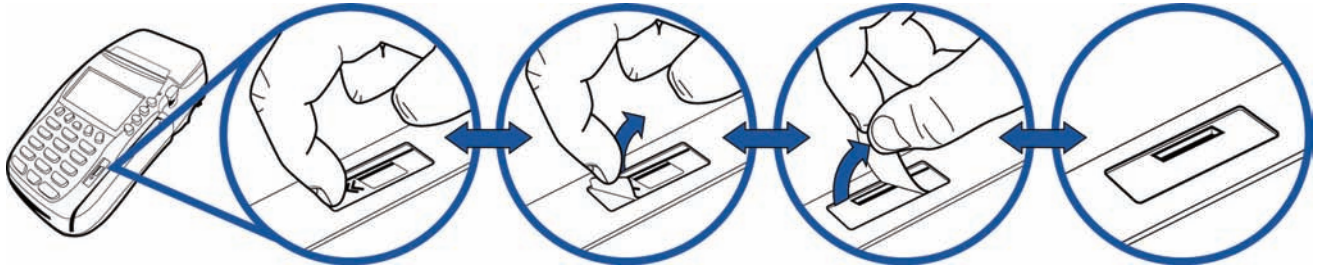

Figure 26 Remove the sticker

- 2 Align the privacy shield with the V^x570 terminal and carefully insert the shield. Make sure that the privacy shield window clears all keys.

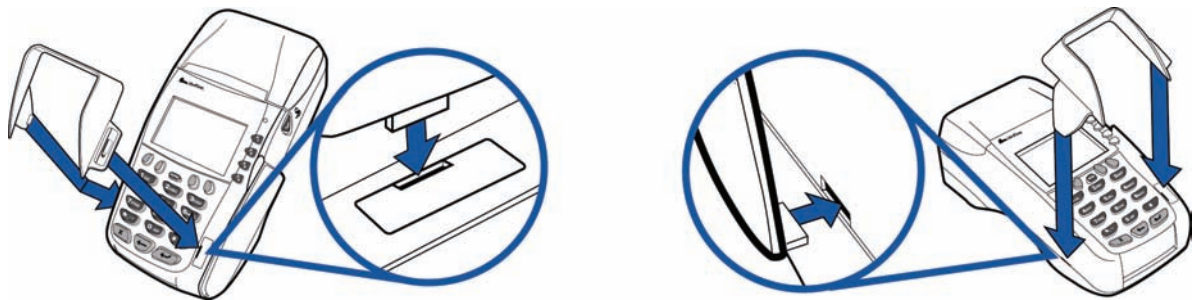

Figure 27 Insert the V^x570 privacy shield

- 3 Press firmly on all edges around the privacy shield to ensure it is correctly seated.

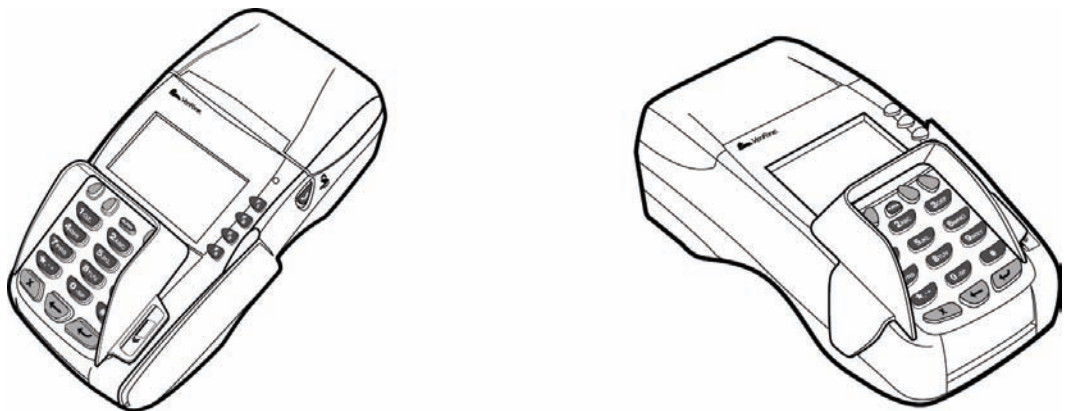

Figure 28 Make sure that the privacy shield is properly seated

Installing the V^x610 Smart Battery

V^x610 wireless terminals use Li-ion *smart* batteries (see [Accessories and Documentation](#) for ordering information). The internal logic of the smart battery prevents both overcharging and undercharging (a fault condition in which the battery level goes well below the minimum acceptable charge and the battery becomes unusable).

NOTE



The V^x610 terminal will operate on battery power or on power pack power. The smart battery charger in the terminal will be active whenever the power pack is connected.

The following are features of the smart battery:

- Two Li-ion cells
- A “fuel gauge” module that
 - monitors state of charge (voltage and percentage of capacity),
 - communicates with the terminal (charge parameters and status),
 - determines full charge capacity (on charge cycle and uninterrupted discharge cycle), and
 - automatically shuts down when cell voltage is extremely low.
- A safety circuit that
 - prevents cell damage from overcharge, over-discharge, or overheating
 - activates when the battery is left in an unused terminal for extended periods.

NOTE



Conserve battery power by turning the V^x610 terminal off when not in use. If the terminal is not to be used for several days, remove the battery from the terminal as it continues to discharge even when the terminal is turned off.

Installation

The V^x610 smart battery fits in a slot on the back of the V^x610 terminal, as shown in [Figure 29](#). The locking tab clicks when the battery is in place. The slot is *keyed*, so that there is only one way to insert the battery.

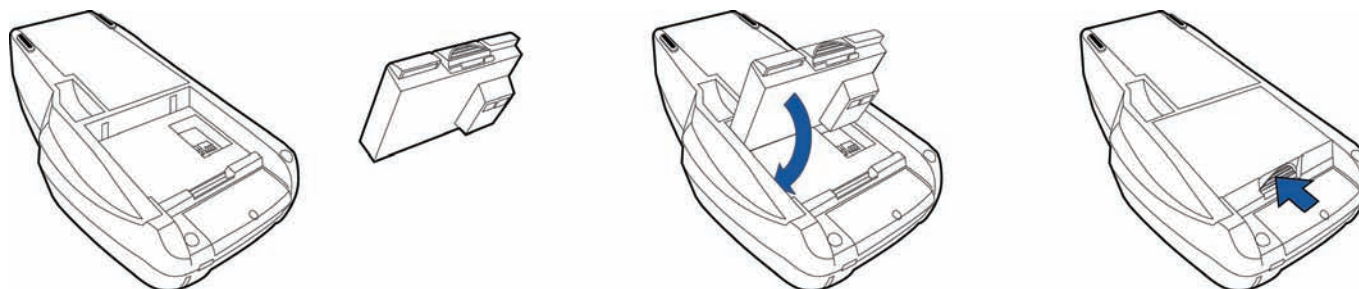

Figure 29 Install the Smart Battery

Removal To remove the V^x610 smart battery, press the locking tab at the top of the battery and pull the smart battery from its slot.

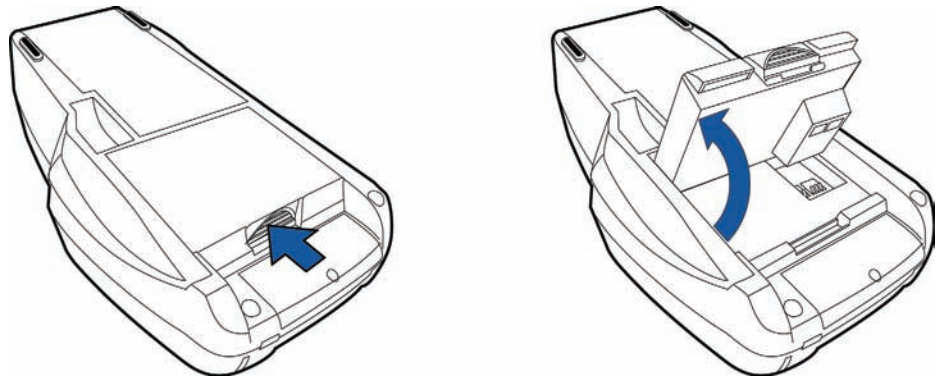

Figure 30 Detaching the Smart Battery from the V^x610 Terminal

Charging After unpacking your V^x610 terminal, install the battery and connect the power pack to the unit for 6 hours. Failure to do so may result in inaccurate battery status messaging.

VeriFone also recommends that the smart battery receive a periodic full discharge. To ensure a full discharge, use the unit until the battery is fully drained.

The smart battery has a safety circuit to protect the Li-ion cells from overcharging and over-discharging. If the battery is over-discharged, the safety circuit shuts down the battery. The battery must then be recharged to restore operation.

NOTE



The V^x610 terminal automatically shuts off when the smart battery reaches the *critically low* charge state. If this occurs, the smart battery must be recharged for a minimum of 1/2 hour before it can power the terminal. *It may take several recharge attempts to reset the safety circuit* when charging a smart battery that has been discharged below this critical state.

Battery Life The V^x610 smart battery can be charged and discharged hundreds of times, but will eventually wear out. When operating times are noticeably shorter than usual, it is time to buy a new battery (see [Accessories and Documentation](#) for ordering information).

WARNING



Do not dispose of batteries in a fire. Li-ion batteries must be recycled or disposed of properly. Do not dispose of Li-ion batteries in municipal waste sites.



Using the V^x610 Spare Battery Charger

The V^x610 spare battery charger can charge two batteries at a time. The LED indicator allows you to see the initial battery condition as well as the charging condition.

To charge a battery 1 Insert the battery by sliding it into place.

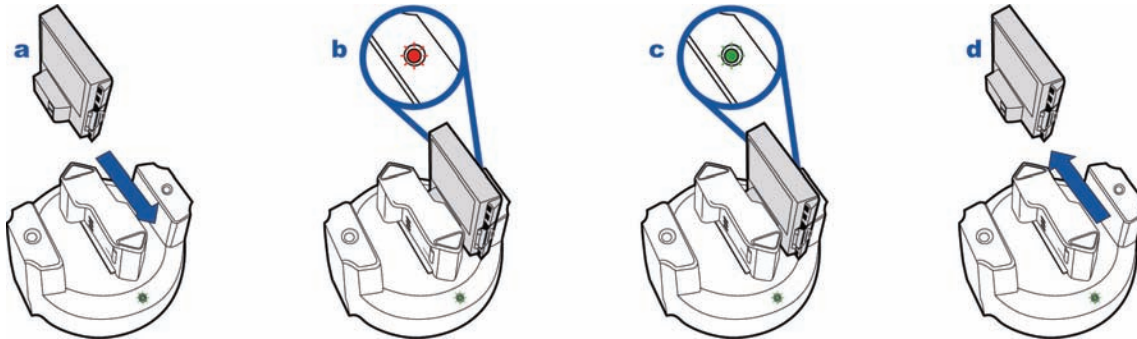

Figure 31 Charging a single battery

2 Notice the LED indicator located on each side of the battery charger.

NOTE



A red light indicates that the battery is charging while the LED changes to green to indicate that the charge has been completed.

3 Once the battery is fully charged, remove the battery by sliding it upward or downward depending on which side of the charger is used.

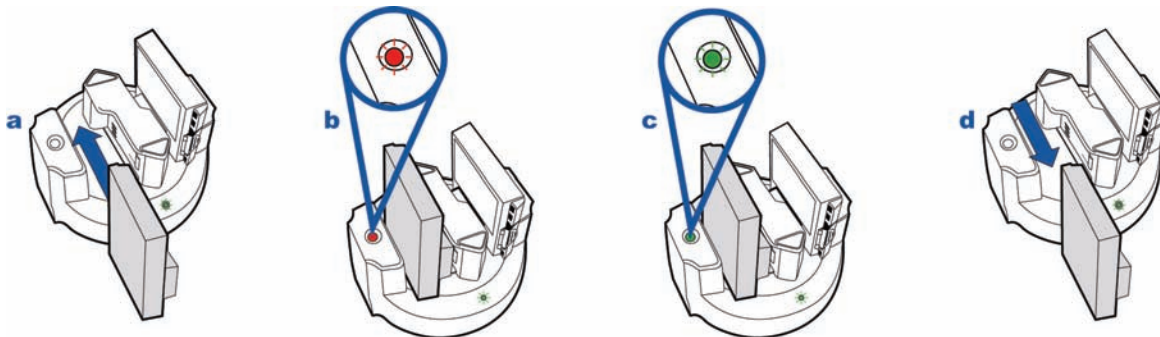

Figure 32 Charging two batteries

NOTE



For best results, when first charging a new battery, charge it in a powered terminal, instead of charging it with the V^x610 spare battery charger.

Using the V^x610 Power Cradle

The power cradle serves both as a docking station and a battery charger for the V^x610 terminal.

To Connect the Power Cradle

- 1 Turn the cradle upside down and then insert round barrel connector into the power port. Route the cable through the cable retainer where provided to secure the power cord.

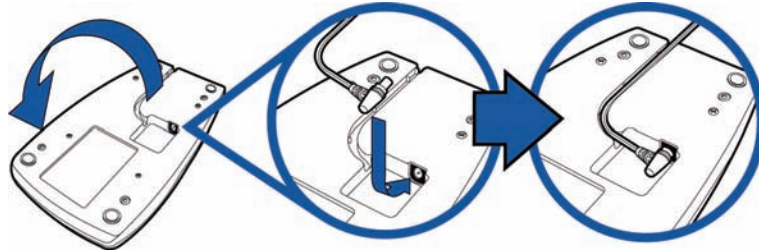

Figure 33 V^x610 Power Cradle Connection

- 2 Insert the AC power cord into the power pack and then plug the AC power cord into a wall outlet or power surge protector. The LED lights up to indicate that it is ready for charging.

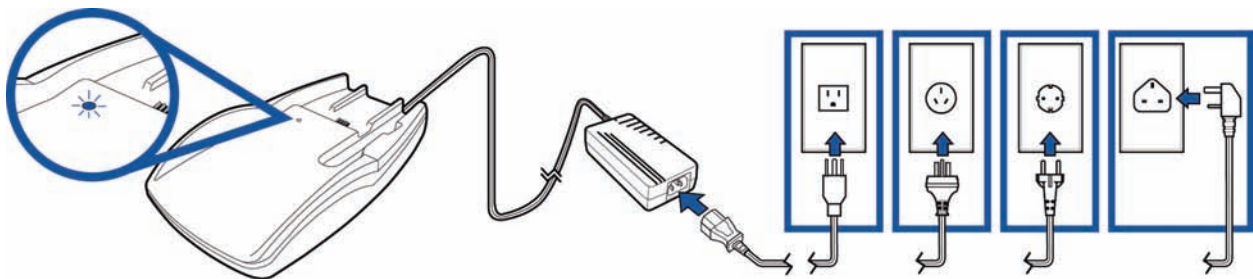

Figure 34 V^x610 Power Cradle Connection

- 3 Remove the protector, identified by the icon at right. Attach the charging strap and then install the screw on the bottom of the power cradle to secure the strap. ⚡

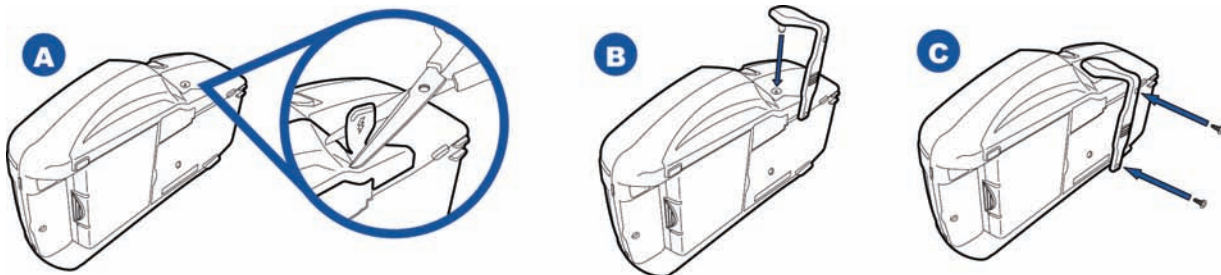

Figure 35 V^x610 Power Cradle Connection

- 4 Place the terminal onto power cradle.

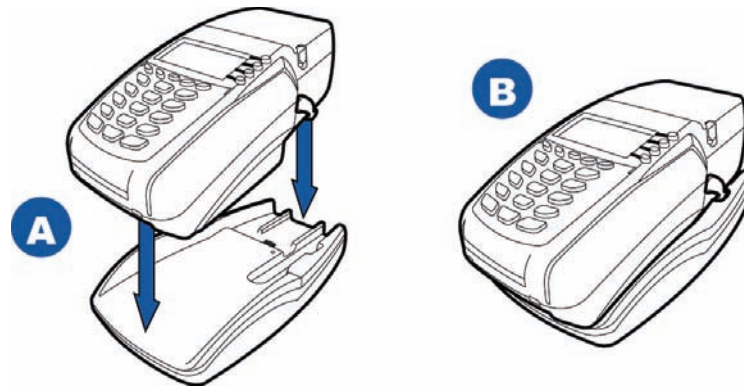

Figure 36 Placing the V^x610 Terminal Onto the Power Cradle

**Installing/
Replacing the
SIM Card
(GSM/GPRS
Models)**

The SIM (Subscriber Identity Module) card is a smart card inserted in the V^x610 GSM/GPRS terminal that contains your GSM/GPRS radio account information. Use the following procedure to replace or install a SIM card.

- 1 Loosen the screw from the GSM/GPRS sled module at the back of the V^x610 terminal.

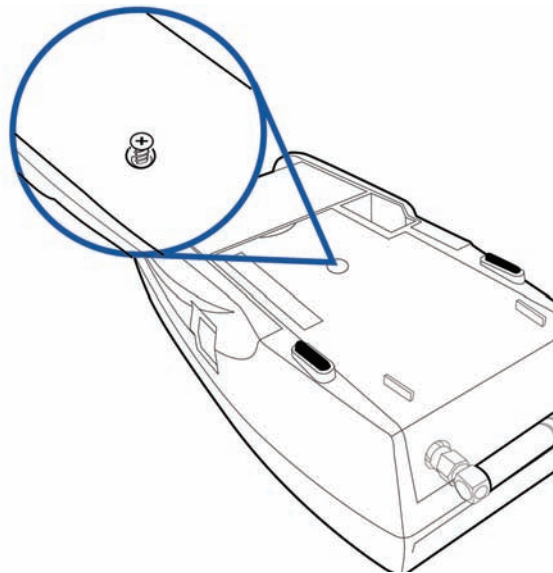

Figure 37 Loosen Retaining Screw

- 2 Detach the GSM/GPRS sled module from the terminal.

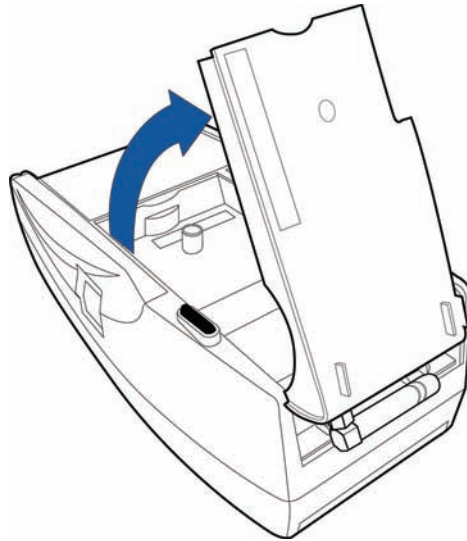

Figure 38 Remove GSM/GPRS Sled Module

- 3 Insert the SIM into the cardholder at the back of the GSM/GPRS sled module.

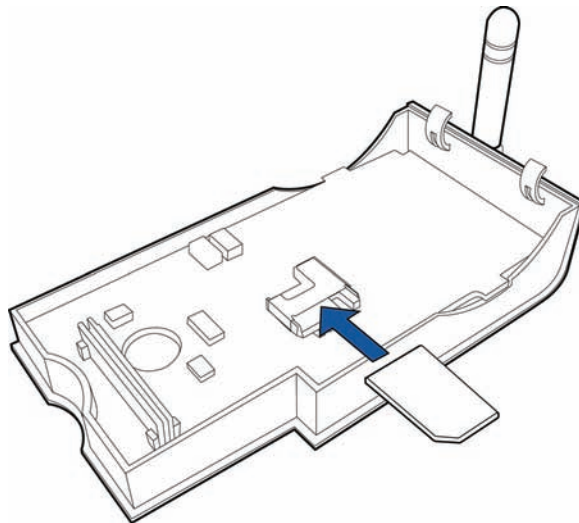

Figure 39 Insert SIM Card Into GSM/GPRS Sled Module

NOTE



The SIM cardholder has a notch on one corner to ensure the SIM card is positioned correctly and for easy orientation in the cardholder. Before inserting the SIM card, position it as shown in [Figure 39](#), with the card's gold contacts facing down.

- 4 Replace the GSM/GPRS sled module in the terminal.

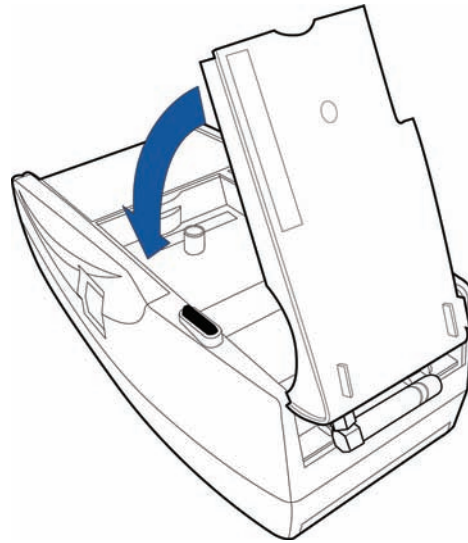

Figure 40 Replace GSM/GPRS Module

- 5 Tighten the retaining screw.

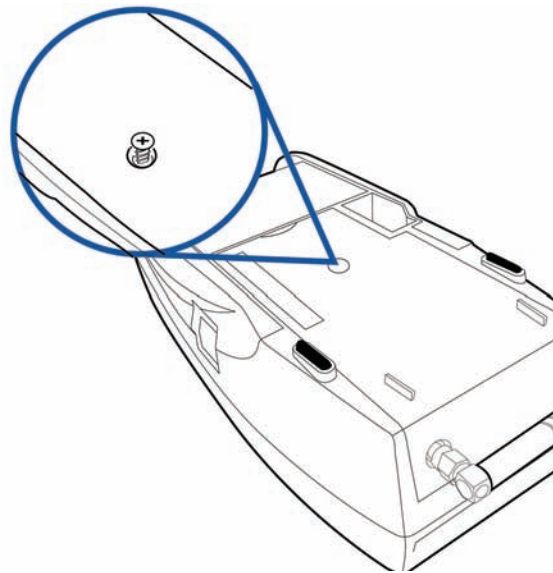

Figure 41 Tighten Retaining Screw

Connecting the V^x610 External Antenna

VeriFone provides an external wireless antenna for some V^x610 terminals. This connection allows communication with your service provider to upload transaction data from the terminal and download system upgrades to the terminal. Radio service is activated by your service provider.

NOTE



Some V^x610 terminals have an internal antenna and this section can be ignored.

Use only the antenna designed for your unit. Failure to use the proper antenna results in the inability to establish a wireless connection.

CAUTION



Never hold the unit by the antenna; doing so may break the connection and void your warranty.

Installation

This section only discusses V^x610 terminals with external antenna. If the V^x610 arrives from manufacture with the antenna unattached, use the following procedure to install the antenna:

- 1 Locate the antenna port on the back side of the V^x610 terminal.
- 2 Align the connector on the end of the antenna with the connector on the end of the terminal.
- 3 Push gently on the center of the base of the antenna until it slides into position.

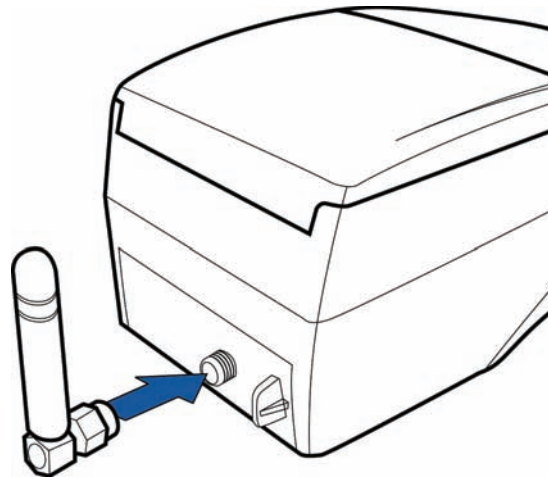

Figure 42 Align Antenna with Antenna Port

- 4 Screw the barrel nut finger tight to retain the antenna.

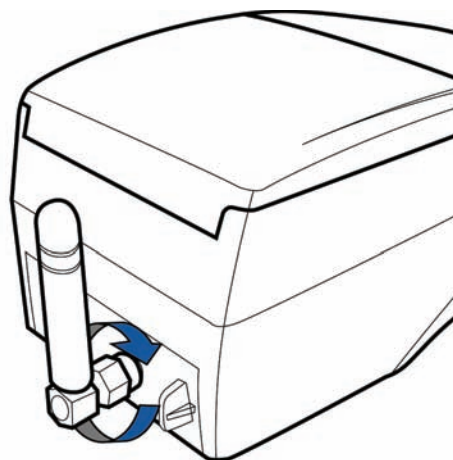

Figure 43 Tighten Antenna Barrel Nut

Orientation To establish good wireless communication (*uplink*), vertically align the antenna with respect to ground and sky. For example, if standing and holding the terminal horizontally, position the antenna approximately at a 90° angle to the unit (that is, pointing up from the ground). This should point the antenna directly at the sky.

If the unit is on a flat surface (for example, a table top) position the antenna so that it points directly at the sky.

NOTE



If an application (for example, SoftPay) is installed in your V^x610 unit, a signal strength indicator may appear on the display.

Replacing the Antenna If your V^x610 terminal has difficulties completing wireless transactions, you may have to replace the antenna. Use the following procedure to replace the antenna:

- 1 Remove the existing antenna from the V^x610 terminal:
 - a Unscrew the barrel nut to loosen the antenna.
 - b Pull gently on the center of the base of the antenna until it slides out of position.
- 2 Align the connector on the end of the new antenna with the connector on the end of the terminal.
- 3 Push gently on the center of the base of the antenna until it slides into position.
- 4 Screw the barrel nut finger tight to retain the antenna.

Conducting Wireless Transactions

To conduct a wireless transaction:

- Ensure the terminal is in an optimal position for transmitting.
- Follow the on-screen instructions provided with your application.

Using the Smart Card Reader

The smart card transaction procedure may vary from one application to another. Verify the procedure with your application provider before performing a smart card transaction.

To Conduct a Smart Card Transaction

- 1 Position a smart card with the contacts facing upward (see [Figure 44](#)).
- 2 Insert the smart card into the smart card reader slot in a smooth, continuous motion until it seats firmly.
- 3 Remove the card only when the application indicates the transaction is complete.

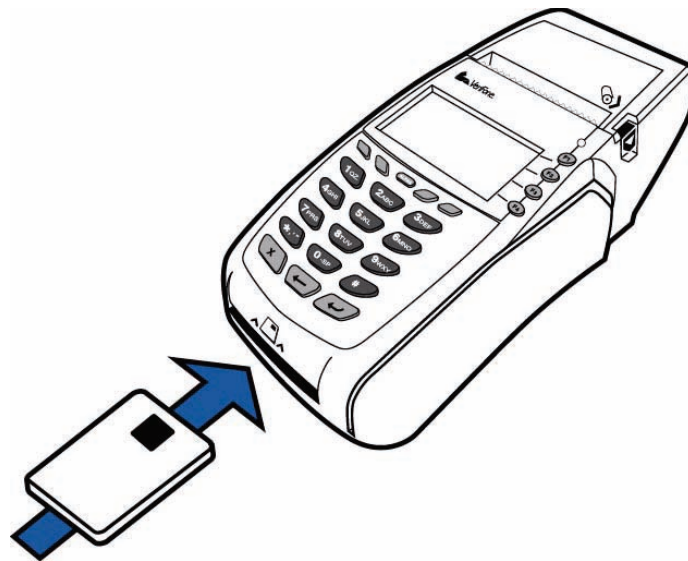

Figure 44 Inserting a Smart Card



CAUTION Leave the smart card in the card reader until the transaction is complete. Premature card removal will invalidate the transaction.

Using the Magnetic Card Reader

The V^x5xx/V^x610 terminal supports credit/debit card transactions.

To Conduct a Credit/Debit Card Transaction

- 1 Position a magnetic card with the stripe in the card reader and facing inward, toward the keypad.
- 2 To ensure a proper read of the magnetic swipe card, the user should insert the magnetic card from the top of the unit, as shown in [Figure 45](#).

- 3 Swipe the card through the magnetic card reader.

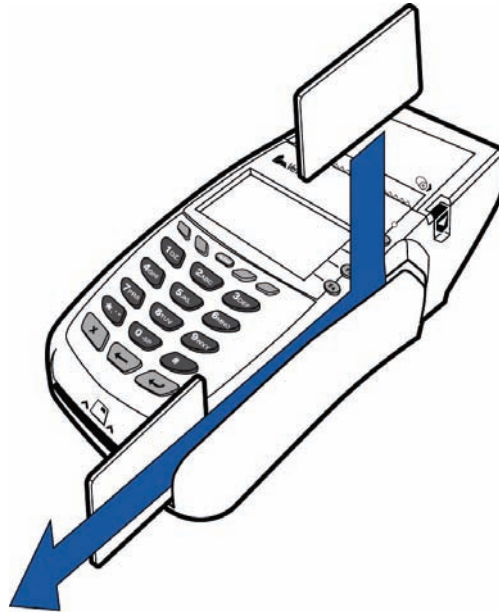

Figure 45 Using the Magnetic Card Reader

Specifications

This chapter discusses power requirements, dimensions, and other specifications of the V^x5xx/V^x610 series of terminal.

Power V^x5xx/V^x610 terminal: 9 V DC; 4.0 A

DC Power Pack UL, ITE listed, Class 2 power supply:

a Input rated: 100 - 240V AC, 50/60 Hz

b Output rated: 8.6 - 9.4V DC 4.0 A

Barrel connector polarity:



- Temperature**
- Operating temperature: 0° to 40° C (32° to 104° F)
 - Storage temperature: -30° to + 60° C (-22° to 140° F)
 - Relative humidity: 5% to 90%; no condensation

External Dimensions **For V^x510 Terminals:**

- Length: 209 mm (8.0 in)
- Width: 102 mm (4.0 in)
- Depth: 72 mm (2.8 in)

For V^x570 Terminals:

- Length: 209 mm (8.0 in)
- Width: 102 mm (4.0 in)
- Depth: 78 mm (3.07 in)

For V^x610 Terminals with Internal Antenna:

- Length: 209 mm (8.0 in)
- Width: 102 mm (4.0 in)
- Depth: 72 mm (2.8 in)

For V^x610 Terminals with External Antenna:

- Length: 214.2 mm (8.4 in)
 - Width: 102 mm (4.0 in)
 - Depth: 72 mm (2.8 in)
-

Maintenance

The V^x5xx/V^x610 terminal has no user-maintainable parts.

Clean the Terminal

To clean the terminal, use a clean cloth slightly dampened with water and a drop or two of mild soap. For stubborn stains, use alcohol or an alcohol-based cleaner.

CAUTION



Never use thinner, trichloroethylene, or ketone-based solvents – they may cause deterioration of plastic or rubber parts.

Do not spray cleaners or other solutions directly onto the keypad or terminal display.

Terminal Contacts

Gently swab the contacts with alcohol or contact cleaner to remove the dirt. It is important that the exposed contacts of the V^x610 battery stay clean and unbent.

CAUTION



Avoid touching the contacts in the raised area in the center of the V^x610 battery and the recessed area on the terminal. Finger oils tarnish contacts, causing bad connections. When operating on battery power and experiencing a high occurrence of bad or incomplete data transfers, clean the contacts.

Smart Card Reader

Do not attempt to clean the smart card reader. Doing so may void any warranty. For smart card reader service, contact your VeriFone distributor or service provider.

VeriFone Service and Support

For terminal problems, contact your local VeriFone representative or service provider.

For product service and repair information:

- USA – VeriFone Service and Support Group, 1-800-VeriFone (837-4366), Monday - Friday, 8 A.M. - 8 P.M., Eastern time
- International – Contact your VeriFone representative

Return a Terminal or Smart Battery for Service

Before returning a V^x5xx/V^x610 terminal, smart battery, or sled module to VeriFone, you must obtain an MRA number. The following procedure describes how to return one or more V^x5xx/V^x610 terminals, smart batteries, or sled modules for repair or replacement (U.S. customers only).

NOTE



International customers are advised to contact their local VeriFone representative for assistance regarding service, return, or replacement of terminals or batteries.

To Return a Terminal for Service

- 1 Get the following information from the printed labels on the bottom of *each* V^x5xx/V^x610 terminal, smart battery, or sled module to be returned:
 - Product ID, including the model and part number. For example, “OMNI 5100” and “Pxxx- xxx-xx,” “Mxxx-xx-xx-xxx,” or “2xxxx-xx”
 - Serial number (S/N xxx-xxx-xxx)
- 2 Obtain the MRA number(s) by completing one of the following:
 - a Call VeriFone toll-free within the United States at 1-800-VeriFone and follow the automated menu options.
 - Select the MRA option from the automated message. The MRA department is open Monday to Friday, 8 A.M.–8 P.M., Eastern Time.
 - Give the MRA representative the information you gathered in Step 1. If the list of serial numbers is long, you can fax the list, along with the information gathered in Step 1, to the MRA department at 727-953-4172 (U.S.).
 - b Address a fax to “VeriFone MRA Dept.” with the model and part number(s)
 - Include a telephone number where you can be reached and your fax number.

- c Complete the Inquiry Contact Form at http://www.verifone.com/aboutus/contact/contact_form.cfm.
 - Address the Subject box with to “VeriFone MRA Dept.”
 - Reference the model and part number in the Note box.

NOTE



One MRA number must be issued for each V^x5xx/V^x610 terminal you return to VeriFone, even if you are returning several of the same model.

- 3 Describe the problem(s).
- 4 Provide the shipping address where the repaired or replacement unit must be returned.
- 5 Keep a record of the following items:
 - Assigned MRA number(s).
 - VeriFone serial number assigned to the V^x5xx/V^x610 terminal, smart battery, or sled module you are returning for service or repair (terminal serial numbers are located on the bottom of the unit).
 - Shipping documentation, such as air bill numbers used to trace the shipment.
 - Model(s) returned (model numbers are located on the VeriFone label on the bottom of the V^x5xx/V^x610 terminal).

Accessories and Documentation

VeriFone produces the following accessories and documentation for the V^x5xx/V^x610 terminal. When ordering, please refer to the part number in the left column.

- VeriFone online store at www.store.verifone.com
- USA – VeriFone Customer Development Center, 800-VeriFone (837-4366), Monday - Friday, 7 A.M. - 8 P.M., Eastern time
- International – Contact your VeriFone representative

Power Pack

Contact your local VeriFone distributor to determine which power pack or power cord fits your needs.

CPS10936-3A DC power pack (universal)

21973-01 AC power cord (US)

Thermal Printer Paper

CRM0039-01 CRM0039 in 30-roll bulk package

CRM0040 High-grade thermal printer paper, 57 mm (2.24-inch) width, 25-meter (82-feet) length; single roll; Available in 20-roll or 50-roll bulk packages

VeriFone Cleaning Kit	02746-01	Cleaning Kit
Telephone Line Cord	00124-17	2.1-meter (7-foot) telephone line cord, black, with modular RJ11-type connectors
Swivel Stand	23050-01	V ^x 510 Swivel Stand

Documentation For V^x510, V^x570, and V^x610 Terminals:

23216	<i>Omni 5xxx and V^x610 Installation Guide</i>
23217	<i>Omni 5xxx and V^x610 Reference Manual</i>
23230	<i>Verix V Operating System Programmer's Manual</i>
23231	<i>Verix V Tools Programmer's Manual</i>

For V^x510 Terminals:

23218	<i>Omni 5100/5150 and V^x510, Omni 3730 Certifications and Regulations</i>
23219	<i>Omni 5100/5150 and V^x5xx Quick Installation Guide</i>

For V^x570 Terminals:

23646	<i>V^x570 Certifications and Regulations</i>
23759	<i>V^x570 Quick Installation Guide</i>
24134	<i>V^x570 Privacy Shield Quick Installation Guide</i>

For V^x610 Terminals:

23640	<i>Omni 56xx and V^x610 Carrying Case Quick Installation Guide</i>
23641	<i>Omni 56xx and V^x610 Attachable Strap/Handstrap Quick Installation Guide</i>
23643	<i>Omni 56xx and V^x610 Quick Installation Guide</i>
23644	<i>Omni 56xx and V^x610 Certifications and Regulations</i>

For V^x510 and V^x610 Terminals:

23642	<i>Omni 5xxx and V^x610 Privacy Shield Quick Installation Guide</i>
-------	---

Troubleshooting Guidelines

The troubleshooting guidelines provided in the following section are included to assist you to successfully install and configure your V^x5xx/V^x610 terminal. If you have problems operating your V^x5xx/V^x610 terminal, please read through these troubleshooting examples.

If the problem persists even after performing the outlined guidelines or if the problem is not described below, contact your local VeriFone representative for assistance. Typical examples of malfunction you may encounter while operating your V^x5xx/V^x610 terminal and steps you can take to resolve them are listed.

NOTE



The V^x5xx/V^x610 terminal comes equipped with tamper-evident labels. The V^x5xx/V^x610 contains no user serviceable parts. Do not, under any circumstance, attempt to disassemble the terminal. Perform only those adjustments or repairs specified in this guide. For all other services, contact your local VeriFone service provider. Service conducted by parties other than authorized VeriFone representatives may void any warranty.

CAUTION



Using an incorrectly rated power supply may damage the terminal or cause it not to work as specified. Use only a VeriFone-supplied power pack with the correct output ratings. Before troubleshooting, ensure that the power supply being used to power the terminal matches the requirements specified on the bottom of the terminal. (See [Chapter 3, Specifications](#), for detailed power supply specifications.) Obtain the appropriately rated power supply before continuing with troubleshooting.

Blank Display

When the terminal display screen does not show correct or clearly readable information:

- Check terminal power connection.
- Remove and reapply power to the terminal.
- Check all cable connections and verify that the telephone line is properly connected.
- If the problem persists, contact your local VeriFone service provider.

Terminal Does Not Dial Out

If the terminal does not dial out:

- Check the telephone line connections.
- Check that the telephone line is working by plugging it into a working telephone and listening for a dial tone.

- Replace the telephone cable that connects the terminal with a cable you know is working correctly.
- If the problem persists, contact your local VeriFone service provider.

Printer Paper Jam

If paper jams inside the printer:

- Press the button on the side of the terminal to unlatch the paper roll cover, then open the cover.
 - Remove the damaged paper from the paper roll and clear the feed mechanism.
 - Install a roll of printer paper, as described in [Installing the Paper Roll in the Printer](#).
 - If the problem persists, it may be due to poor paper quality. Install a new roll of higher-quality paper.

WARNING



Poor-quality paper may jam the printer. To order high-quality VeriFone paper, refer to [Accessories and Documentation](#).

Keypad Does Not Respond

If the keypad does not respond properly:

- Check the terminal display. If it displays the wrong character or nothing at all when you press a key, follow the steps outlined in [Transactions Fail To Process](#).
- If pressing a function key does not perform the expected action, refer to the user documentation for that application to ensure you are entering data correctly.
- If the problem persists, contact your local VeriFone representative.

Peripheral Device Does Not Work

If any peripheral device (PINpad or smart card reader) does not work properly:

- Check the power cord connection to the peripheral device.
- Check that the device connected to the proper port has power and is functioning properly. If possible, perform a self-test on the device in question.
- The cable connecting the optional device to the terminal serial port may be defective. Try a different serial cable. See [Connecting Optional Device\(s\)](#).
- If the problem persists, contact your local VeriFone representative.

Transactions Fail To Process

There are several reasons why the terminal may not be processing transactions. Use the following steps to troubleshoot failures.

Check the Magnetic Card Reader

- Perform a test transaction using one or more different magnetic stripe cards to ensure the problem is not a defective card.

- Ensure that you are swiping cards properly. With the card reader, the black magnetic stripe on the card should face down and inward, toward the keypad and must be inserted from the top of the terminal (see [Figure 45](#)).
- Process a transaction manually, using the keypad instead of the card reader. If the manual transaction works, the problem may be a defective card reader.
- Contact your VeriFone distributor or service provider.
- If the manual transaction does not work, proceed to [Check the Telephone Line](#).

Check the Smart Card Reader

- Perform a test transaction using several different smart cards to ensure the problem is not a defective card.
- Ensure that the card is inserted correctly and that the card is not removed prematurely.
- Ensure the MSAM cards are properly inserted in the cardholders and that the cardholders are properly secured (see [Installing/Replacing MSAM Cards](#)).
- Contact your VeriFone distributor or service provider.
- If the manual transaction does not process, proceed to [Check the Telephone Line](#).

Check the Telephone Line

- Disconnect the telephone line from the terminal and connect it to a working telephone to check for a dial tone. If there is no dial tone, replace the telephone cable.
- If the problem appears to be with the telephone line, check with the party you are trying to call to see if their system is operational. If they are not experiencing difficulties with their line, contact the telephone company and have your line checked.
- If the telephone line works, contact your local VeriFone representative for assistance.

Printer Does Not Print

If the printer does not work properly:

- Check battery status or terminal power connection. The printer will not print if there is an insufficient charge remaining in the battery to complete the print operation. (For V^x610 terminals only.)
- Check if the printer is out of paper and that the roll is properly installed. Open the paper roll cover and install a new roll of printer paper or ensure that the roll is feeding from the bottom.
- Verify that the printer roller and paper roll dust cover are properly installed.
- If the problem persists, contact your VeriFone distributor or service provider.

Terminal Display Does not Show Correct/Readable Information

- Connect the terminal in to a known-good power supply (if you have one) to see if this clears the problem.
- Recharge or replace the battery. (For V^x610 terminals only.)
- If the problem persists, contact your local VeriFone representative for assistance.

V^x610 Terminal Does Not Start

- Ensure that you press the ENTER/ON key for approximately 3 seconds, until the unit lights up.
- Ensure that the smart battery charge state is not below the critically low level.
- Recharge or replace the smart battery.

V^x610 Smart Battery Will Not Charge

Each new V^x610 smart battery must receive a full charge to initialize its full charge capacity.

NOTE



Allow the V^x610 terminal to remain connected to the power pack for 6 hours to ensure the battery receives a full charge.

Conserve battery power by turning the V^x610 terminal off when not in use. If the terminal will not be used for several days, remove the battery from the terminal as it continues to discharge even when the terminal is turned off.

NOTE



The V^x610 terminal automatically shuts off when the smart battery reaches the *critically low* charge state. If this occurs, the smart battery must recharge a minimum of 1/2 hour before it can power the terminal. *It may take several recharge attempts to reset the safety circuit* when charging a smart battery that has been discharged below this critical state.

Printer Does Not Print

If the printer does not work properly:

- Check battery status or terminal power connection. The printer will not print if there is an insufficient charge remaining in the battery to complete the print operation. (For V^x610 terminals only.)
- Check if the printer is out of paper and that the roll is properly installed. Open the paper roll cover and install a new roll of printer paper or ensure that the roll is feeding from the bottom.
- Verify that the printer roller and paper roll dust cover are properly installed.
- If the problem persists, contact your VeriFone distributor or service provider.



A

- accessories **50**
 - documentation **51**
 - ordering **51**
 - power packs **50**
 - swivel stand **51**
 - telephone line cord **51**
 - thermal printer paper **50**
 - VeriFone cleaning kit **51**

- antennas
 - installation **40**
 - orientation **41**
 - replacing **41**

B

- batteries
 - extending the battery life **34**
 - See also smart battery
- battery mode
 - Vx610 **30**

C

- check readers **27**
- cleaning kit **51**
- connection ports **16**
- contact VeriFone **49**

D

- dial out problems
 - troubleshooting **53**
- displays
 - troubleshooting **53, 56**
- documentation **50**
 - acronym definitions **7**
 - conventions **7**
 - ordering **51**

E

- electrical considerations **14, 22**
- electrostatic discharges **22**
 - prevention **22**

- environmental factors **13**
- external printers
 - RS-232 port connection **27**
- external printers supported
 - VeriFone external printers **27**

I

- installation **9**
 - connecting a check reader to Vx510 or Vx570 **25**
 - connecting a check reader to Vx610 **27**
 - connecting a PINpad to Vx510 or Vx570 **24**
 - connecting a PINpad to Vx610 **26**
 - connecting a smart card reader to Vx510 or Vx570 **24**
 - connecting a smart card reader to Vx610 **26**
 - connecting a smart card writer to Vx510 or Vx570 **24**
 - connecting optional device(s) **24**
 - connecting the terminal power pack **28**
 - connecting the terminal to a telephone line **18**
 - MSAM cards **22**
 - peripherals **27**
 - terminal location **13**
 - unpacking the shipping carton **14**

K

- keypads
 - troubleshooting **54**

M

- maintenance
 - cleaning the terminal **47**
 - cleaning the terminal contacts **47**
 - returning a battery for repair or replacement **49**
 - returning a terminal for repair or replacement **49**
- MSAM cardholders **22**
- MSAM cards
 - installation **22**

O

- optional devices

connecting **24**

P

paper jams

troubleshooting **54**

paper rolls

for thermal printers **19, 54**

installation **19**

peripheral devices

troubleshooting **54**

peripherals

check readers **27**

installation **27**

printers **27**

troubleshooting **54**

power packs

AC version **50**

connecting **28**

DC version **50**

ordering **50**

printer paper

ordering **50**

printers

troubleshooting **55, 56**

privacy shields **31**

Vx510 **31**

Vx570 **32**

Vx610 **31**

S

service

returning a battery for repair or replacement **49**

returning a terminal for repair or replacement **49**

SIM cards

for GSM models **37**

installation **37**

smart battery **34**

battery life **34**

charging **34**

conserving power **33**

disposal **34**

features **33**

installation **33**

recharging **34**

removal **34**

troubleshooting **56**

specifications

DC power pack **45**

power **45**

temperature **45**

weight **46**

T

technical support

contacting VeriFone **49**

returning a battery for repair or replacement **49**

returning a terminal for repair or replacement **49**

telephone line connections **18**

telephone line cords

ordering **51**

terminal features

general **15**

terminals

accessories **50**

benefits **10**

cleaning **47**

documentation **50**

electrical considerations **14**

environmental factors **13**

features **15**

repair **49**

replacement **49**

service and support **49**

troubleshooting **53, 56**

thermal printer paper

storage **19**

thermal printers

about the thermal printer paper **19, 54**

paper jams **54**

troubleshooting **55, 56**

transactions

smart cards **42**

wireless **42**

troubleshooting

batteries **56**

displays **53, 56**

guidelines **53**

keypads **54**

peripheral devices **54**

peripherals **54**

printers **55, 56**

terminal transactions **54**

terminals **53, 56**

V

VeriCentre Appliance Management Suite
simultaneous downloads **11**

V^x5xx/V^x610

multi-application capability **11**

V^x610

starting on battery power **30**

troubleshooting **56**

V^x610 startup

battery mode **30**

W

wireless connection

CDMA **11**

GSM/GPRS **11**

Wi-Fi **11**

wireless transactions **42**



VeriFone, Inc.
2099 Gateway Place, Suite 600
San Jose, CA, 95110 USA
Tel: (800) VeriFone (837-4366)
www.verifone.com

Omni 5xxx and V^x5xx/V^x610

Installation Guide

