

# FCC RADIO TEST REPORT

according to

47 CFR FCC Part 15 Subpart C § 15.225

**Equipment** : Point of Sale Terminal  
**Brand Name** : VeriFone  
**Model No.** : VX520 3G  
**Filing Type** : New Application  
**Applicant** : VeriFone Inc.  
1400 West Stanford Ranch Road Suite 200 Rocklin CA  
95765 USA  
**FCC ID** : B32VX520WCDMA  
**Manufacturer** : Inventec Appliances (Pudong) Co., Ltd.  
No. 789, Pu Xing Road, Shanghai, P.R.C.  
**Received Date** : Oct. 21, 2012  
**Final Test Date** : Apr. 16, 2013

## Statement

The test result in this report refers exclusively to the presented test model / sample.

Without written approval of SPORTON International Inc., the test report shall not be reproduced except in full.

The measurements and test results shown in this test report were made in accordance with the procedures and found in compliance with the limit given in **ANSI C63.4-2003 and ANSI C63.10-2009** and **47 CFR FCC Part 15 Subpart C**.

The test equipment used to perform the test is calibrated and traceable to NML/ROC.



**SPORTON INTERNATIONAL INC.**

**No. 52, Hwa Ya 1<sup>st</sup> Rd., Hwa Ya Technology Park, Kwei-Shan Hsiang, Tao Yuan Hsien, Taiwan, R.O.C.**

**Table of Contents**

**1. SUMMARY OF THE TEST RESULT ..... 2**

**2. GENERAL INFORMATION..... 3**

2.1 Product Details ..... 3

2.2 Accessories ..... 3

2.3 Table for Test Modes ..... 4

2.4 Table for Testing Locations ..... 4

2.5 Table for Supporting Units ..... 4

2.6 Test Mode ..... 5

2.7 Test Configurations ..... 5

**3. TEST RESULT ..... 7**

3.1 AC Power Line Conducted Emissions Measurement ..... 7

3.2 Field Strength of Fundamental Emissions and Mask Measurement ..... 12

3.3 20dB Spectrum Bandwidth Measurement ..... 16

3.4 Radiated Emissions Measurement ..... 18

3.5 Frequency Stability Measurement ..... 25

3.6 Antenna Requirements ..... 28

**4. LIST OF MEASURING EQUIPMENT ..... 29**

**5. TEST LOCATION..... 30**

**6. TAF CERTIFICATE OF ACCREDITATION..... 31**

**APPENDIX A. PHOTOGRAPHS OF EUT**

**APPENDIX B. SETUP PHOTOGRAPHS**

**REVISION HISTORY**

<b>REPORT NO.</b>	<b>VERSION</b>	<b>DESCRIPTION</b>	<b>ISSUED DATE</b>
FR202101-01	Rev. 01	Initial issue of report	Apr. 25, 2013

# CERTIFICATE OF COMPLIANCE

according to

47 CFR FCC Part 15 Subpart C § 15.225

**Equipment** : **Point of Sale Terminal**

**Brand Name** : **VeriFone**

**Model No.** : **VX520 3G**

**Applicant** : **VeriFone Inc.**

1400 West Stanford Ranch Road Suite 200 Rocklin CA  
95765 USA

Sporton International as requested by the applicant to evaluate the EMC performance of the product sample received on Oct. 21, 2012 would like to declare that the tested sample has been evaluated and found to be in compliance with the tested rule parts. The data recorded as well as the test configuration specified is true and accurate for showing the sample's EMC nature.



Reviewed by: Joseph Lin / Supervisor



Approved by: Jones Tsai / Manager

**SPORTON INTERNATIONAL INC.**

**No. 52, Hwa Ya 1<sup>st</sup> Rd., Hwa Ya Technology Park, Kwei-Shan Hsiang, Tao Yuan Hsien, Taiwan, R.O.C.**



### 1. SUMMARY OF THE TEST RESULT

Applied Standard: 47 CFR FCC Part 15 Subpart C					
Part	FCC Rule	IC Rule	Description of Test	Result	Under Limit
3.1	15.207	Gen 7.2.2	AC Power Line Conducted Emissions	Complies	8.90dB at 27.118MHz
3.2	15.225(a)(b)(c)	A2.6	Field Strength of Fundamental Emissions	Complies	44.47dB at 13.560MHz
3.3	2.1049	-	20dB Spectrum Bandwidth	Complies	
3.4	15.225(d) 15.209	A2.6	Radiated Emissions	Complies	3.48dB at 35.130MHz
3.5	15.225(e)	A2.6	Frequency Stability	Complies	
3.6	15.203	-	Antenna Requirements	Complies	

Test Items	Uncertainty	Remark
AC Power Line Conducted Emissions	±2.3dB	Confidence levels of 95%
Field Strength of Fundamental Emissions	±0.8dB	Confidence levels of 95%
20dB Spectrum Bandwidth / Frequency Stability	±8.5×10 <sup>-8</sup>	Confidence levels of 95%
Radiated / Band Edge Emissions (9kHz~30MHz)	±0.8dB	Confidence levels of 95%
Radiated Emissions (30MHz~1000MHz)	±1.9dB	Confidence levels of 95%
Temperature	±0.7°C	Confidence levels of 95%
Humidity	±3.2%	Confidence levels of 95%
DC / AC Power Source	±1.4%	Confidence levels of 95%

## 2. GENERAL INFORMATION

### 2.1 Product Details

For more detailed features description, please refer to the manufacturer's specifications or user's manual.

Items	Description
Power Type	9.3Vdc from Adapter 7.2Vdc from Li-ion Battery
Modulation	ASK
Channel Number	1
Channel Band Width (99%)	2.240kHz
Max. Field Strength	79.53dBµV/m
Test Freq. Range	13.553 ~ 13.567MHz
Carrier Frequencies	13.56 MHz (Ch. 1)
Antenna	PCB Antenna

**Remark:** It's dual SIM device. We only tested SIM1 since SIM1 and SIM2 can be switched and the circuits from SIM to module are totally the same.

### 2.2 Accessories

Specification of Accessory		
Adapter 1	Brand Name	VeriFone
	Model Name	SM09003A
	Power Rating	I/P: 100-240Vac, 50/60Hz, 2A ; O/P:9.3Vdc, 4A
	Power Cord	1.8 meter, non-shielded cable, with ferrite core
Adapter 2	Brand Name	VeriFone
	Model Name	AU1370933g
	Power Rating	I/P: 100-240Vac, 50/60Hz, 2A ; O/P:9.3Vdc, 4A
	Power Cord	1.8 meter, non-shielded cable, with ferrite core
Battery 1	Brand Name	VeriFone
	Manufacture	Palladium Energy
	Model Name	24016-01-R
Battery 2	Brand Name	VeriFone
	Manufacture	SANYO
	Model Name	24016-01-R
Battery 3	Brand Name	VeriFone
	Manufacture	SAMSUNG
	Model Name	24016-01-R

### 2.3 Table for Test Modes

Investigation has been done on all the possible configurations for searching the worst cases. The following table is a list of the test modes shown in this test report.

Test Items	Mode	Channel
AC Power Line Conducted Emissions	CTX	-
Field Strength of Fundamental Emissions	CTX	1
20dB Spectrum Bandwidth	CTX	1
Radiated Emissions 9kHz~30MHz	CTX	1
Radiated Emissions 9kHz~10 <sup>th</sup> Harmonic Band Edge Emissions	CTX	1
Frequency Stability	Un-modulation	1

Note:

- 1, CTX=continuously transmitting.
- 2, The EUT choose "HW DQ Test", then choose the LTLS Test → Carrier. Then, the EUT will get into the engineering modes to continuously transmit at 13.56MHz.

### 2.4 Table for Testing Locations

Test Site No.	Site Category	Location
CO05-HY	Conduction	Hwa Ya
TH02-HY	OVEN Room	Hwa Ya
03CH07-HY	SAC	Hwa Ya

Semi Anechoic Chamber (SAC).

### 2.5 Table for Supporting Units

Support Unit	Manufacturer	Model	FCC ID
System Simulator	R&S	CMU 200	N/A
GPS Station	T&E	GS-50	N/A
Notebook	DELL	Latitude E6320	FCC DoC
LCD Monitor	DELL	U2410	FCC DoC
iPod	Apple	A1285	FCC DoC
HUB	D-Link	DES-1005A	FCC DoC
Exchange	Sun Moon Star	SMS-4 PLUS	FCC DoC
Point of Sale terminal	VeriFone	VX570	FCC DoC
USB flash drive	Transcend	JetFlash8G	FCC DoC
SD Card	SanDisk	16G	FCC DoC

## 2.6 Test Mode

Test Items	Function Type
AC Conducted Emission	Mode 1: GSM850 Idle + Battery 1 + Adapter 1 + MSR On + Smart Card + SAM Card + Printer + RFID On + GPS Rx<Fig.1>
	Mode 2: GSM850 Idle + Battery 2 + Adapter 2 + MSR On + Smart Card + SAM Card + Printer + RFID On + GPS Rx<Fig.1>
	Mode 3: GSM850 Idle + Battery 3 + Adapter 2 + MSR On + Smart Card + SAM Card + Printer + RFID On + GPS Rx<Fig.1>
	Mode 4: GSM850 Idle + Battery 1 + Adapter 1 + MSR On + Smart Card + SAM Card + Printer + RFID On + GPS Rx + USB flash drive + RJ-45 Link + RJ-11 (Load) + Mini USB Cable Link with Notebook<Fig.2>
Radiated Emissions	Mode 1: RFID Tx + Adapter 1 + Battery 1
	Mode 2: RFID Tx + Adapter 2 + Battery 2
	Mode 3: RFID Tx + Adapter 1 + Battery 3
<b>Remark:</b>	
1. The worst case of AC Conducted Emission is mode 3; only the test data of this mode was reported.	
2. The worst case of Radiated Emissions is mode 1; only the test data of this mode was reported.	

## 2.7 Test Configurations

### <AC Conducted Emissions>

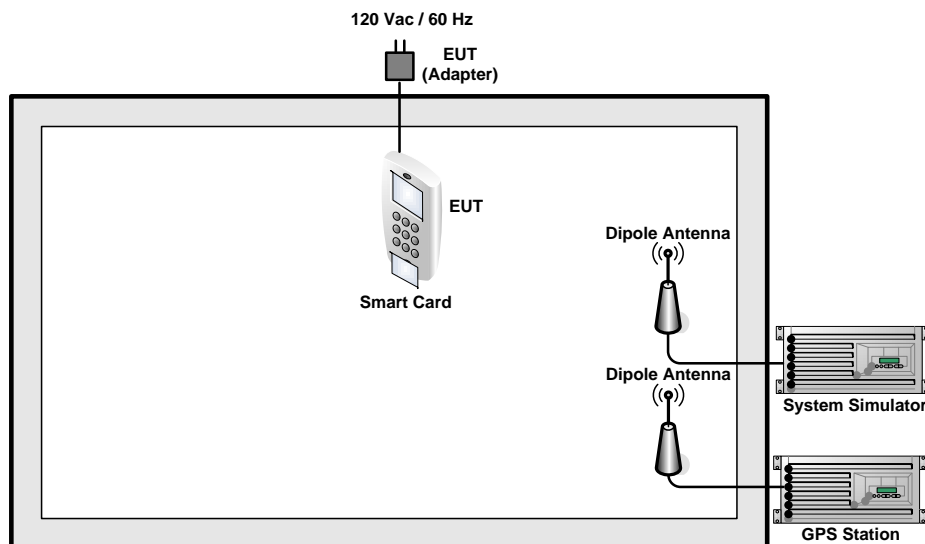

<Fig.1>



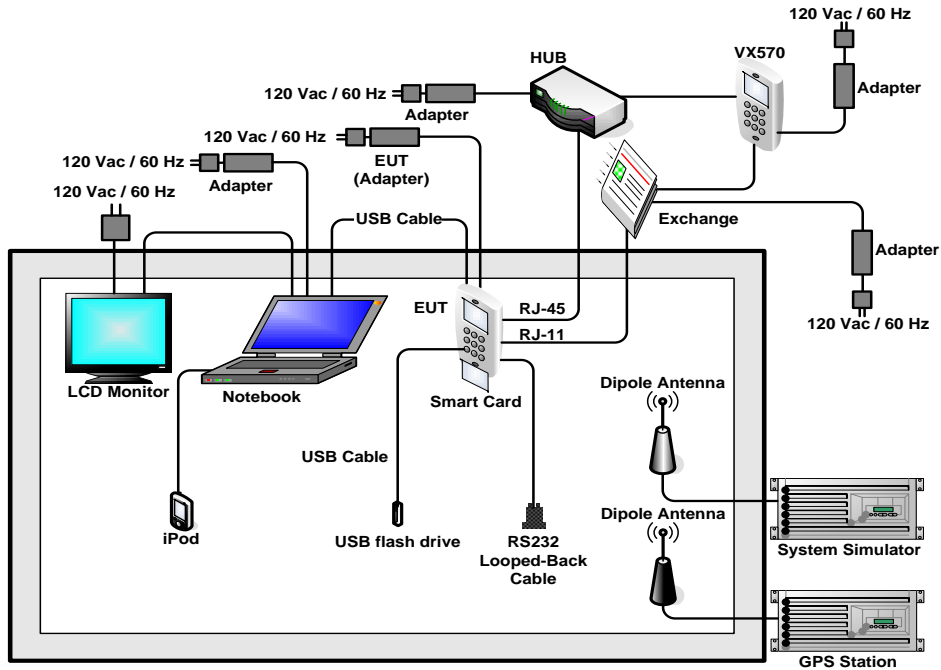

<Fig.2>

**Fundamental Emissions and Mask Measurement**

For radiated emissions 9kHz~30MHz/

For radiated emissions 30MHz~1GHz

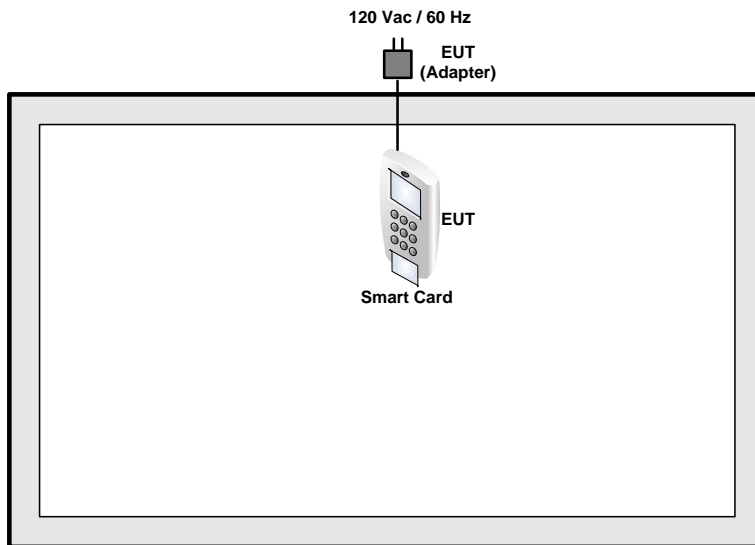

### 3. TEST RESULT

#### 3.1 AC Power Line Conducted Emissions Measurement

##### 3.1.1 Limit

For a Low-power Radio-frequency device which is designed to be connected to the AC power line, the radio frequency voltage that is conducted back onto the AC power line on any frequency or frequencies within the band 150 kHz to 30 MHz shall not exceed below limits table.

Frequency (MHz)	QP Limit (dB $\mu$ V)	AV Limit (dB $\mu$ V)
0.15~0.5	66~56	56~46
0.5~5	56	46
5~30	60	50

##### 3.1.2 Measuring Instruments and Setting

Please refer to section 4 of equipments list in this report. The following table is the setting of the receiver.

Receiver Parameters	Setting
Attenuation	10 dB
Start Frequency	0.15 MHz
Stop Frequency	30 MHz
IF Bandwidth	9 KHz

##### 3.1.3 Test Procedures

1. Configure the EUT according to ANSI C63.4. The EUT or host of EUT has to be placed 0.4 meter far from the conducting wall of the shielding room and at least 80 centimeters from any other grounded conducting surface.
2. Connect EUT or host of EUT to the power mains through a line impedance stabilization network (LISN).
3. All the support units are connected to the other LISNs. The LISN should provide 50uH/50ohms coupling impedance.
4. The frequency range from 150 KHz to 30 MHz was searched.
5. Set the test-receiver system to Peak Detect Function and Specified Bandwidth with Maximum Hold Mode.
6. The measurement has to be done between each power line and ground at the power terminal.

3.1.4 Test Setup Layout

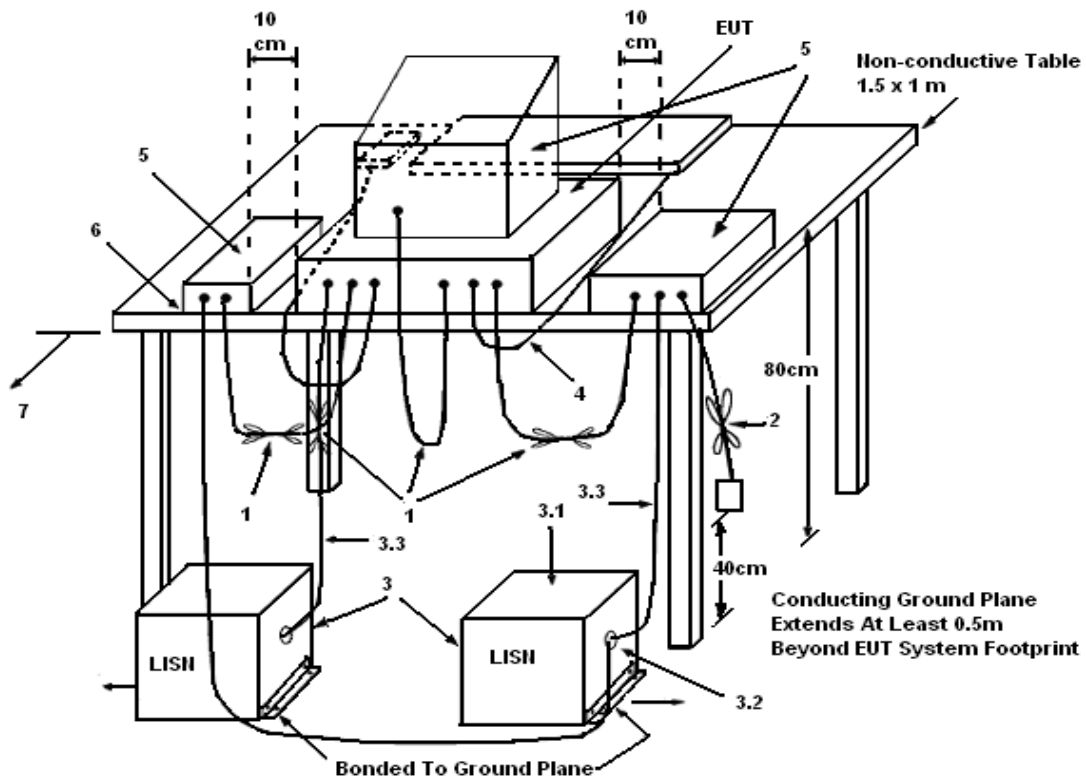

LEGEND:

- (1) Interconnecting cables that hang closer than 40 cm to the ground plane shall be folded back and forth in the center forming a bundle 30 to 40 cm long.
- (2) I/O cables that are not connected to a peripheral shall be bundled in the center. The end of the cable may be terminated, if required, using the correct terminating impedance. The overall length shall not exceed 1 m.
- (3) EUT connected to one LISN. Unused LISN measuring port connectors shall be terminated in 50 Ω. LISN can be placed on top of, or immediately beneath, reference ground plane.
  - (3.1) All other equipment powered from additional LISN(s).
  - (3.2) Multiple outlet strip can be used for multiple power cords of non-EUT equipment.
  - (3.3) LISN at least 80 cm from nearest part of EUT chassis.
- (4) Cables of hand-operated devices, such as keyboards, mice, etc., shall be placed as for normal use.
- (5) Non-EUT components of EUT system being tested.
- (6) Rear of EUT, including peripherals, shall all be aligned and flush with rear of tabletop.
- (7) Rear of tabletop shall be 40 cm removed from a vertical conducting plane that is bonded to the ground plane.



**3.1.5 Test Deviation**

There is no deviation with the original standard.

**3.1.6 EUT Operation during Test**

The EUT was placed on the test table and programmed in transmitting function.

3.1.7 Results of AC Power Line Conducted Emissions Measurement

<b>Final Test Date</b>	Apr. 16, 2013	<b>Test Site No.</b>	CO05-HY
<b>Temperature</b>	20~22°C	<b>Humidity</b>	45~47%
<b>Test Engineer</b>	Slash Huang	<b>Configuration</b>	Transmitting Mode (13.56MHz)
<b>Mode</b>	GSM850 Idle + Battery 3 + Adapter 2 + MSR On + Smart Card + SAM Card + Printer + RFID On + GPS Rx		

Line

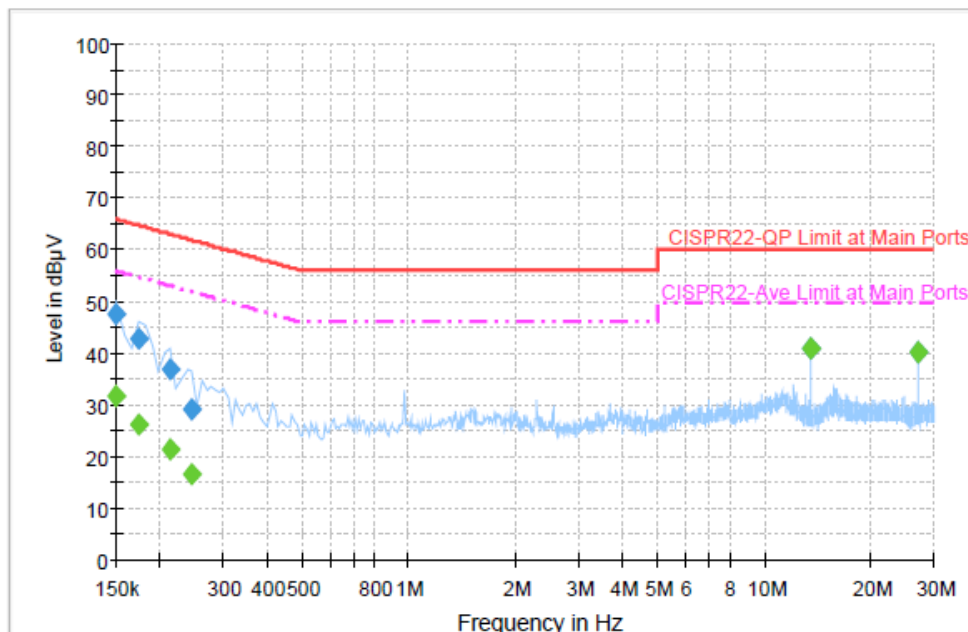

Final Result: Quasi-Peak

Frequency (MHz)	Quasi-Peak (dBµV)	Filter	Line	Corr. (dB)	Margin (dB)	Limit (dBµV)
0.150000	47.5	Off	L1	19.4	18.5	66.0
0.174000	42.9	Off	L1	19.4	21.9	64.8
0.214000	36.8	Off	L1	19.4	26.2	63.0
0.246000	29.2	Off	L1	19.4	32.7	61.9
13.558000	40.8	Off	L1	19.8	19.2	60.0
27.118000	40.2	Off	L1	19.9	19.8	60.0

Final Result: Average

Frequency (MHz)	Average (dBµV)	Filter	Line	Corr. (dB)	Margin (dB)	Limit (dBµV)
0.150000	31.8	Off	L1	19.4	24.2	56.0
0.174000	26.2	Off	L1	19.4	28.6	54.8
0.214000	21.6	Off	L1	19.4	31.4	53.0
0.246000	16.6	Off	L1	19.4	35.3	51.9
13.558000	40.9	Off	L1	19.8	9.1	50.0
27.118000	40.3	Off	L1	19.9	9.7	50.0

Neutral

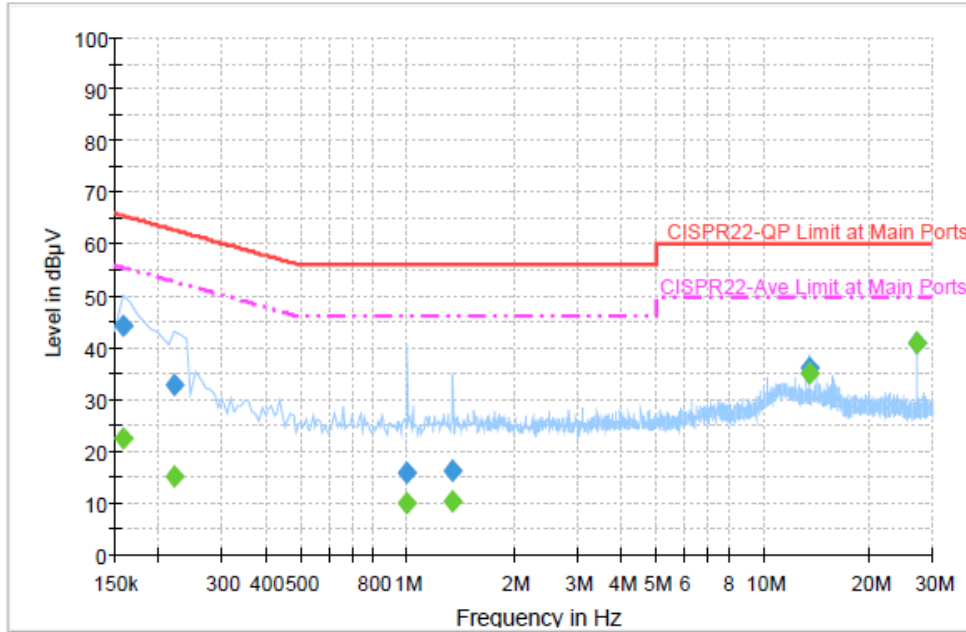

Final Result: Quasi-Peak

Frequency (MHz)	Quasi-Peak (dBµV)	Filter	Line	Corr. (dB)	Margin (dB)	Limit (dBµV)
0.158000	44.1	Off	N	19.3	21.5	65.6
0.222000	32.7	Off	N	19.4	30.0	62.7
0.998000	15.7	Off	N	19.4	40.3	56.0
1.342000	16.2	Off	N	19.5	39.8	56.0
13.558000	36.2	Off	N	19.9	23.8	60.0
27.118000	40.9	Off	N	20.1	19.1	60.0

Final Result: Average

Frequency (MHz)	Average (dBµV)	Filter	Line	Corr. (dB)	Margin (dB)	Limit (dBµV)
0.158000	22.4	Off	N	19.3	33.2	55.6
0.222000	15.1	Off	N	19.4	37.6	52.7
0.998000	9.9	Off	N	19.4	36.1	46.0
1.342000	10.2	Off	N	19.5	35.8	46.0
13.558000	35.2	Off	N	19.9	14.8	50.0
27.118000	41.1	Off	N	20.1	8.9	50.0

Note: Level = Read Level + LISN Factor + Cable Loss.

### 3.2 Field Strength of Fundamental Emissions and Mask Measurement

#### 3.2.1 Limit

Field strength of fundamental emissions limit:

The field strength of fundamental emissions shall not exceed 15848 microvolts/meter at 30 meters.

The emissions limit in this paragraph is based on measurement instrumentation employing a QP detector.

Frequencies (MHz)	Field Strength (microvolts/meter)	Field Strength (dBµV/m) at 10m	Field Strength (dBµV/m) at 3m
13.553 ~ 13.567MHz	15848 at 30m	103.08 (QP)	124 (QP)

Mask limit:

Rules and specifications	CFR 47 Part 15 section 15.225(a)-(d)				
Description	Compliance with the spectrum mask is tested using a spectrum analyzer with RB set to a 1kHz for the band 13.553~13.567MHz				
Limit	Freq. of Emission (MHz)	Field Strength (µV/m) at 30m	Field Strength (dBµV/m) at 30m	Field Strength (dBµV/m) at 10m	Field Strength (dBµV/m) at 3m
	1.705~13.110	30	29.5	48.58	69.5
	13.110~13.410	106	40.5	59.58	80.5
	13.410~13.553	334	50.5	69.58	90.5
	13.553~13.567	15848	84.0	103.08	124.0
	13.567~13.710	334	50.5	69.58	90.5
	13.710~14.010	106	40.5	59.58	80.5
	14.010~30.000	30	29.5	48.58	69.5

#### 3.2.2 Measuring Instruments and Setting

Please refer to section 4 of equipments list in this report. The following table is the setting of the receiver.

Receiver Parameter	Setting
Attenuation	Auto
Center Frequency	Fundamental Frequency
RB	9 kHz
Detector	QP

**3.2.3 Test Procedures**

1. Configure the EUT according to ANSI C63.4. The EUT was placed on the top of the turntable 0.8 meter above ground. The phase center of the loop receiving antenna mounted antenna tower was placed 3 meters far away from the turntable.
2. Power on the EUT and all the supporting units. The turntable was rotated by 360 degrees to determine the position of the highest radiation.
3. The height of the receiving antenna was fixed at one meter above ground to find the maximum emissions field strength.
4. For Fundamental emissions, use the receiver to measure QP reading.
5. When the radiated emissions limits are expressed in terms of the average value of the emissions, and pulsed operation is employed, the measurement field strength shall be determined by averaging over one complete pulse train, including blanking intervals, as long as the pulse train does not exceed 0.1 seconds. As an alternative (provided the transmitter operates for longer than 0.1 seconds) or in cases where the pulse train exceeds 0.1 seconds, the measured field strength shall be determined from the average absolute voltage during a 0.1 second interval during which the field strength is at its maximum value.
6. Compliance with the spectrum mask is tested using a spectrum analyzer with RB set to a 1kHz for the band 13.553~13.567MHz.

**3.2.4 Test Setup Layout**

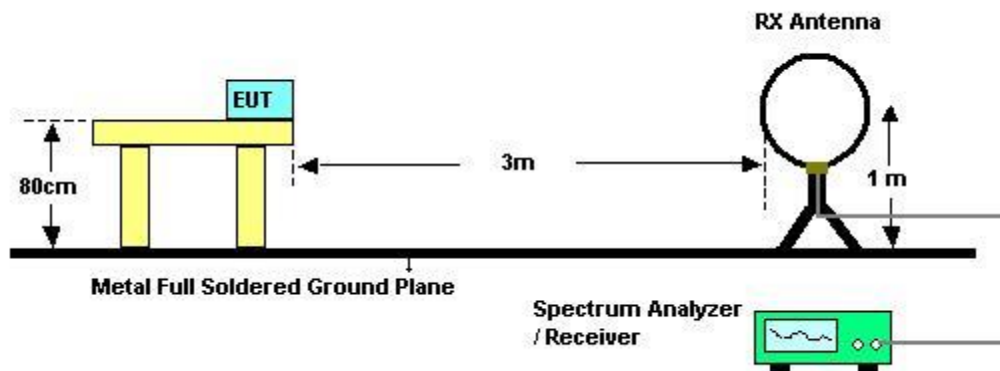

**3.2.5 Test Deviation**

There is no deviation with the original standard.

**3.2.6 EUT Operation during Test**

The EUT was programmed to be in continuously transmitting mode.





3.2.7 Test Result of Field Strength of Fundamental Emissions

<b>Final Test Date</b>	Apr. 15, 2013	<b>Test Site No.</b>	03CH07-HY
<b>Temperature</b>	22~24°C	<b>Humidity</b>	51~53%
<b>Test Engineer</b>	Beer Chang	<b>Configurations</b>	Ch. 1

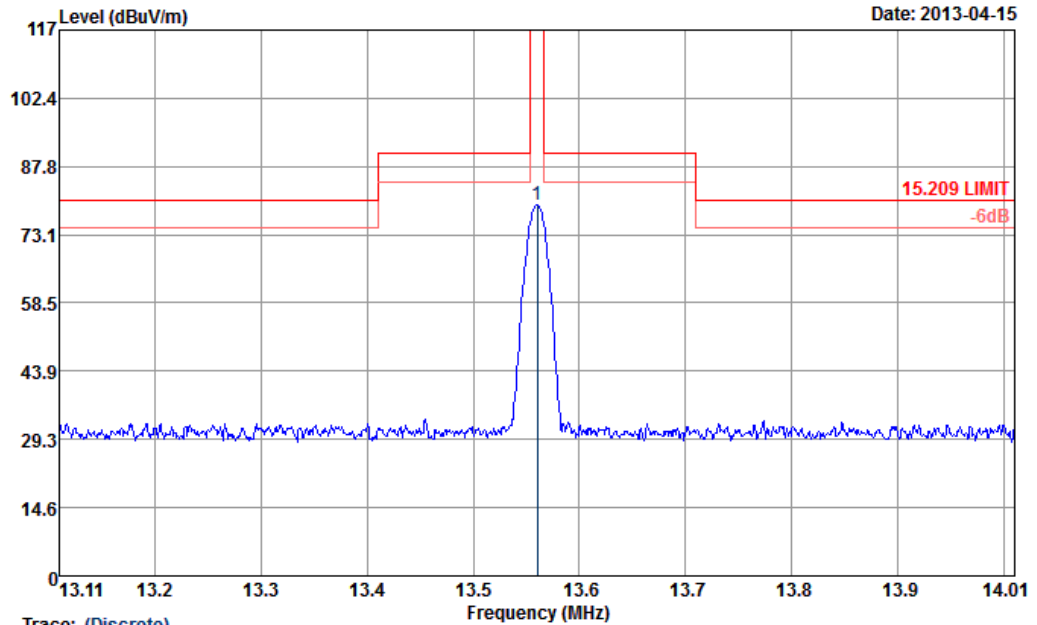

Trace: (Discrete)  
 Site : 03CH07-HY  
 Condition : 15.209 LIMIT 3m NFC FACTOR(120912)-H HORIZONTAL  
 Project : FR 202101-01  
 Mode : 1

	Freq	Level	Over	Limit	ReadAntenna	Cable	Preamp	A/Pos	T/Pos	Remark
	MHz	dBuV/m	dB	dBuV/m	dBuV	dB/m	dB	dB	cm	deg
1	13.56	79.53	-44.47	124.00	59.38	19.75	0.40	0.00	100	173 QP

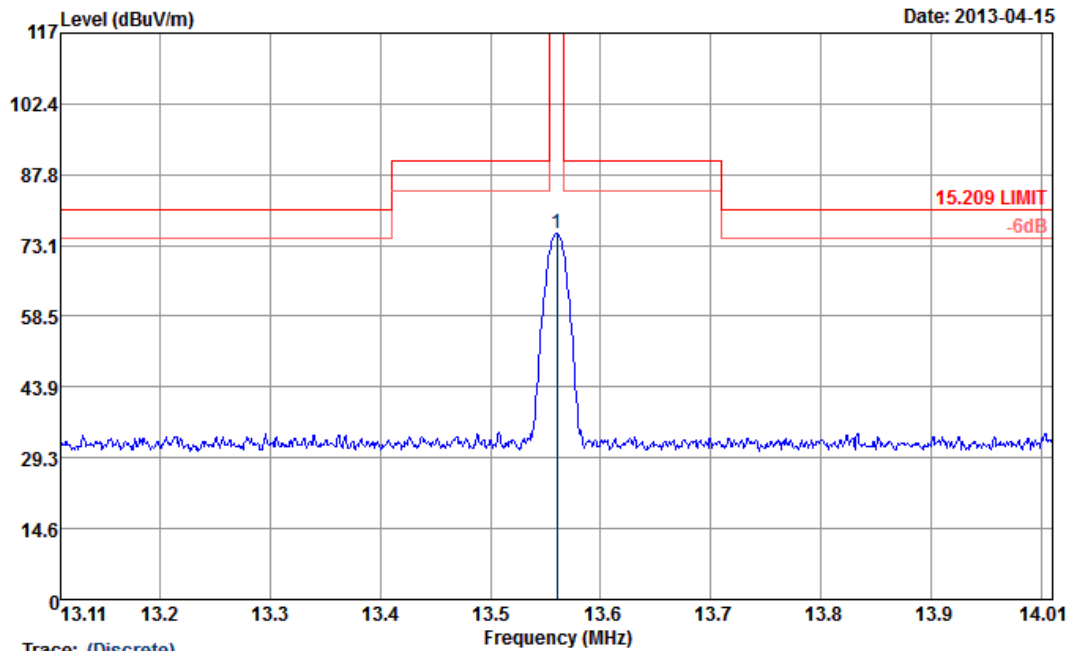

Trace: (Discrete)

Site : 03CH07-HY  
 Condition : 15.209 LIMIT 3m NFC FACTOR(120912)-V VERTICAL  
 Project : FR 202101-01  
 Mode : 1

Freq	Level	Over Limit		ReadAntenna	Cable	Preamp	A/Pos	T/Pos	Remark	
		Limit	Line							Level
MHz	dBuV/m	dB	dBuV/m	dBuV	dB/m	dB	dB	cm	deg	
1	13.56	75.64	-48.36	124.00	55.49	19.75	0.40	0.00	100	90 QP

Note:

Emission level (dBμV/m) = 20 log Emission level (μV/m).

Measured distance is 3m.

All emissions emit form non-RFID function of digital unintentional emissions. All RFID's spurious emissions are below 20dB of limits.

### 3.3 20dB Spectrum Bandwidth Measurement

#### 3.3.1 Limit

Intentional radiators must be designed to ensure that the 20 dB bandwidth of the emissions in the specific band (13.553 ~ 13.567MHz).

#### 3.3.2 Measuring Instruments and Setting

Please refer to section 4 of equipments list in this report. The following table is the setting of the spectrum analyzer.

Spectrum Parameters	Setting
Attenuation	Auto
Span Frequency	> 20dB Bandwidth
RB	1 kHz
VB	3 kHz
Detector	Peak
Trace	Max Hold
Sweep Time	Auto

#### 3.3.3 Test Procedures

1. The transmitter output (antenna port) was connected to the spectrum analyzer in peak hold mode.
2. The resolution bandwidth of 1 kHz and the video bandwidth of 3 kHz were used.
3. Measured the spectrum width with power higher than 20dB below carrier.

#### 3.3.4 Test Setup Layout

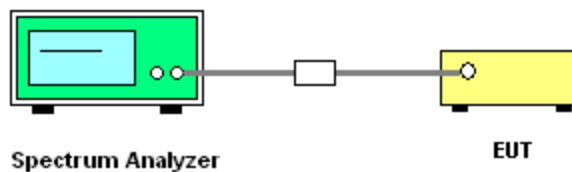

#### 3.3.5 Test Deviation

There is no deviation with the original standard.

#### 3.3.6 EUT Operation during Test

The EUT was programmed to be in continuously transmitting mode.



3.3.7 Test Result of 20dB Spectrum Bandwidth

Final Test Date	Apr. 12, 2013	Test Site No.	TH02-HY
Temperature	22~24°C	Humidity	53~55%
Test Engineer	Tommy Lee	Configurations	Ch. 1

Frequency	20dB BW (kHz)	99% OBW (kHz)	Frequency range (MHz) $f_L > 13.553\text{MHz}$	Frequency range (MHz) $f_H < 13.567\text{MHz}$	Test Result
13.56 MHz	2.640	2.240	13.55854	13.56118	Complies

20 dB / 99% Bandwidth Plot on 13.56 MHz

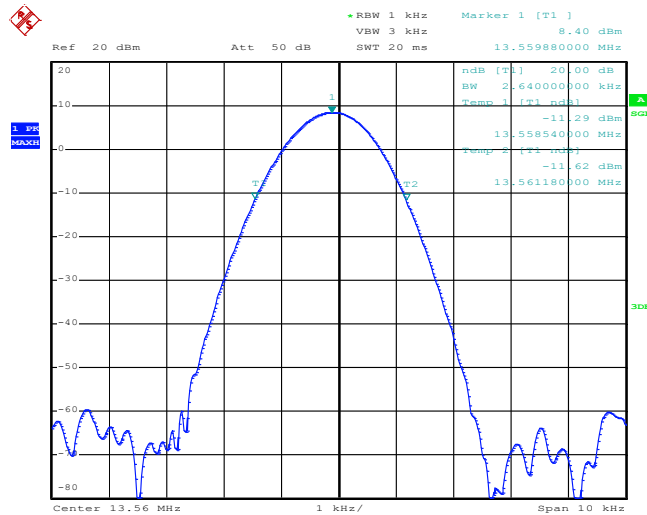

Date: 12.APR.2013 17:32:10

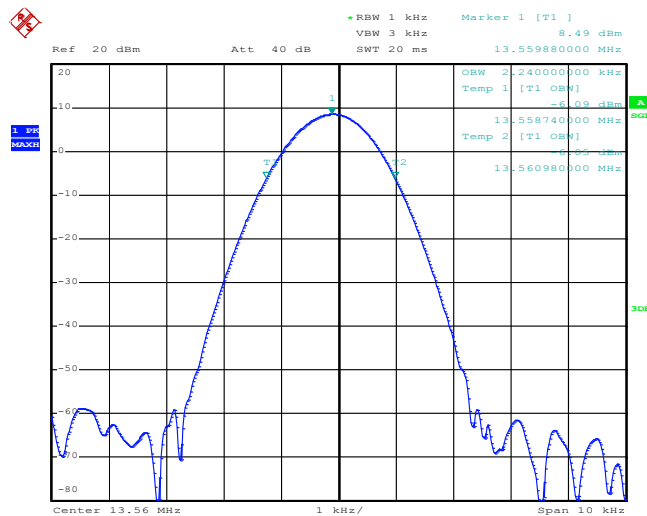

Date: 12.APR.2013 17:33:06

### 3.4 Radiated Emissions Measurement

#### 3.4.1 Limit

The field strength of any emissions which appear outside of 13.553 ~ 13.567MHz band shall not exceed the general radiated emissions limits.

<b>Frequencies (MHz)</b>	<b>Field Strength (micorvolts/meter)</b>	<b>Measurement Distance (meters)</b>
0.009~0.490	2400/F(KHz)	300
0.490~1.705	24000/F(KHz)	30
1.705~30.0	30	30
30~88	100	3
88~216	150	3
216~960	200	3
Above 960	500	3

#### 3.4.2 Measuring Instruments and Setting

Please refer to section 4 of equipments list in this report. The following table is the setting of receiver.

<b>Receiver Parameter</b>	<b>Setting</b>
Attenuation	Auto
Start ~ Stop Frequency	9kHz~150kHz / RB 200Hz for QP
Start ~ Stop Frequency	150kHz~30MHz / RB 9kHz for QP
Start ~ Stop Frequency	30MHz~1000MHz / RB 120kHz for QP

#### 3.4.3 Test Procedures

1. Configure the EUT according to ANSI C63.4. The EUT was placed on the top of the turntable 0.8 meter above ground. The phase center of the receiving antenna mounted on the top of a height-variable antenna tower was placed 3 meters far away from the turntable.
2. Power on the EUT and all the supporting units. The turntable was rotated by 360 degrees to determine the position of the highest radiation.
3. The height of the broadband receiving antenna was varied between one meter and four meters above ground to find the maximum emissions field strength of both horizontal and vertical polarization.
4. For each suspected emissions, the antenna tower was scan (from 1 M to 4 M) and then the turntable was rotated (from 0 degree to 360 degrees) to find the maximum reading.
5. Set the test-receiver system to Peak or CISPR quasi-peak Detect Function with specified bandwidth under Maximum Hold Mode.



6. When the radiated emissions limits are expressed in terms of the average value of the emissions, and pulsed operation is employed, the measurement field strength shall be determined by averaging over one complete pulse train, including blanking intervals, as long as the pulse train does not exceed 0.1 seconds. As an alternative (provided the transmitter operates for longer than 0.1 seconds) or in cases where the pulse train exceeds 0.1 seconds, the measured field strength shall be determined from the average absolute voltage during a 0.1 second interval during which the field strength is at its maximum value.
7. In case the emission is lower than 30MHz, loop antenna has to be used for measurement and the recorded data should be QP measured by receiver. High – Low scan is not required in this case.

### 3.4.4 Test Setup Layout

For radiated emissions below 30MHz

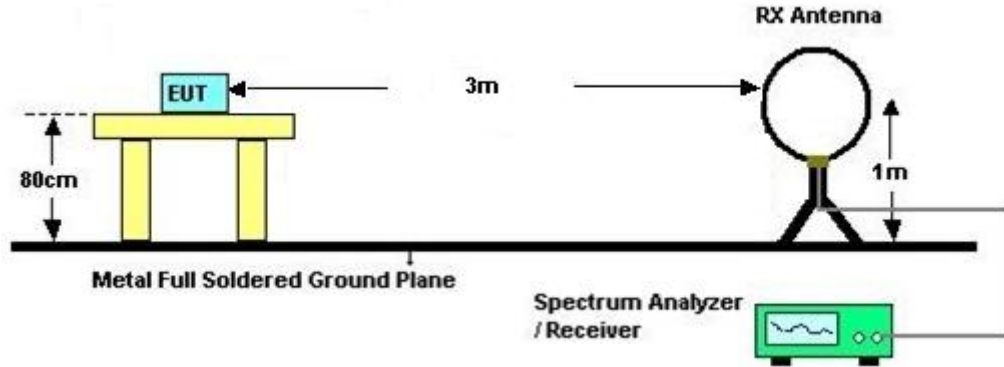

For radiated emissions above 30MHz

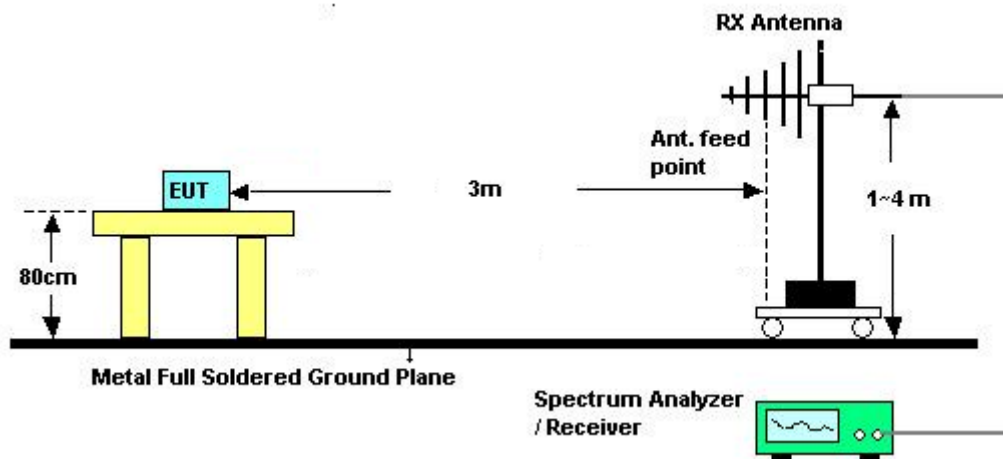

### 3.4.5 Test Deviation

There is no deviation with the original standard.

### 3.4.6 EUT Operation during Test

The EUT was programmed to be in continuously transmitting mode.



3.4.7 Results of Radiated Emissions (9 kHz~30MHz)

Final Test Date	Apr. 15, 2013	Test Site No.	03CH07-HY
Temperature	22~24°C	Humidity	51~53%
Test Engineer	Beer Chang	Configurations	Ch. 1

Horizontal

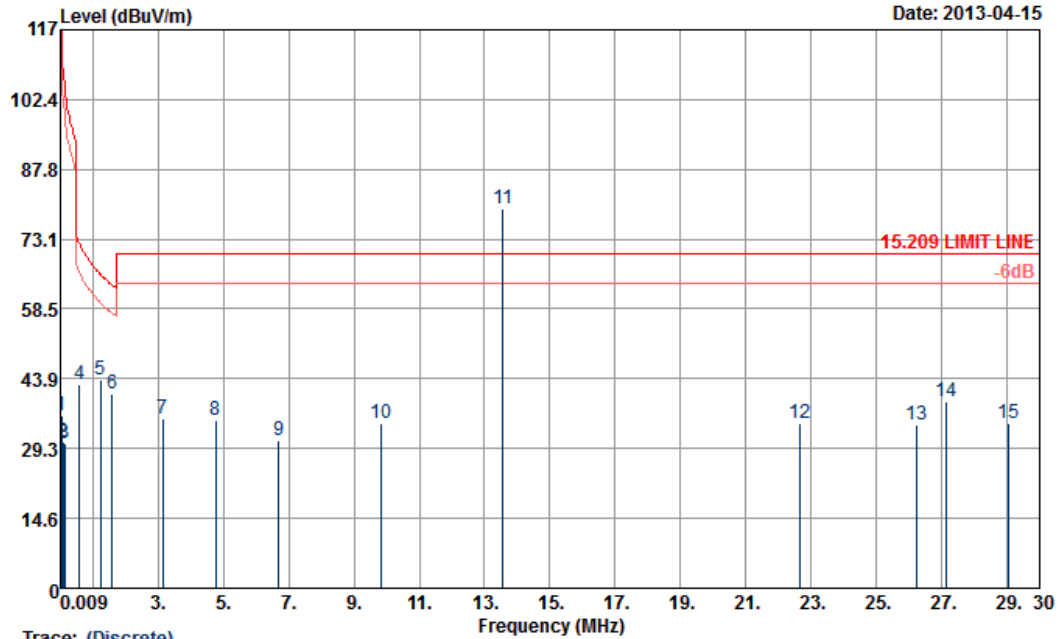

Trace: (Discrete)

Site : 03CH07-HY  
 Condition : 15.209 LIMIT LINE 3m NFC FACTOR(120912)-H HORIZONTAL  
 Project : FR 202101-01  
 Mode : 1

	Freq	Level	Over Limit	Limit Line	ReadAntenna Level	Cable Preamp	A/Pos	T/Pos	Remark
	MHz	dBuV/m	dB	dBuV/m	dBuV	dB/m	dB	dB	cm deg
1	0.04	36.29	-80.41	116.70	15.83	20.17	0.29	0.00	--- QP
2	0.08	30.56	-78.46	109.02	10.20	20.07	0.29	0.00	--- QP
3	0.14	30.32	-74.62	104.94	9.97	20.06	0.29	0.00	--- QP
4	0.59	42.57	-29.59	72.16	22.26	20.00	0.31	0.00	--- QP
5	1.23	43.57	-22.22	65.79	23.25	20.01	0.31	0.00	--- QP
6	1.58	40.70	-22.91	63.61	20.36	20.01	0.33	0.00	--- QP
7	3.13	35.68	-34.32	70.00	15.31	20.03	0.34	0.00	--- QP
8	4.75	35.31	-34.69	70.00	14.97	19.98	0.36	0.00	--- QP
9	6.70	30.88	-39.12	70.00	10.65	19.86	0.37	0.00	--- QP
10	9.84	34.63	-35.37	70.00	14.49	19.75	0.39	0.00	--- QP
11 *	13.56	79.53			59.38	19.75	0.40	0.00	--- QP
12	22.67	34.63	-35.37	70.00	13.87	20.32	0.44	0.00	--- QP
13	26.21	34.06	-35.94	70.00	13.19	20.40	0.47	0.00	--- QP
14	27.12	39.09	-30.91	70.00	18.23	20.38	0.48	0.00	--- QP
15	29.03	34.63	-35.37	70.00	13.89	20.23	0.51	0.00	--- QP





Vertical

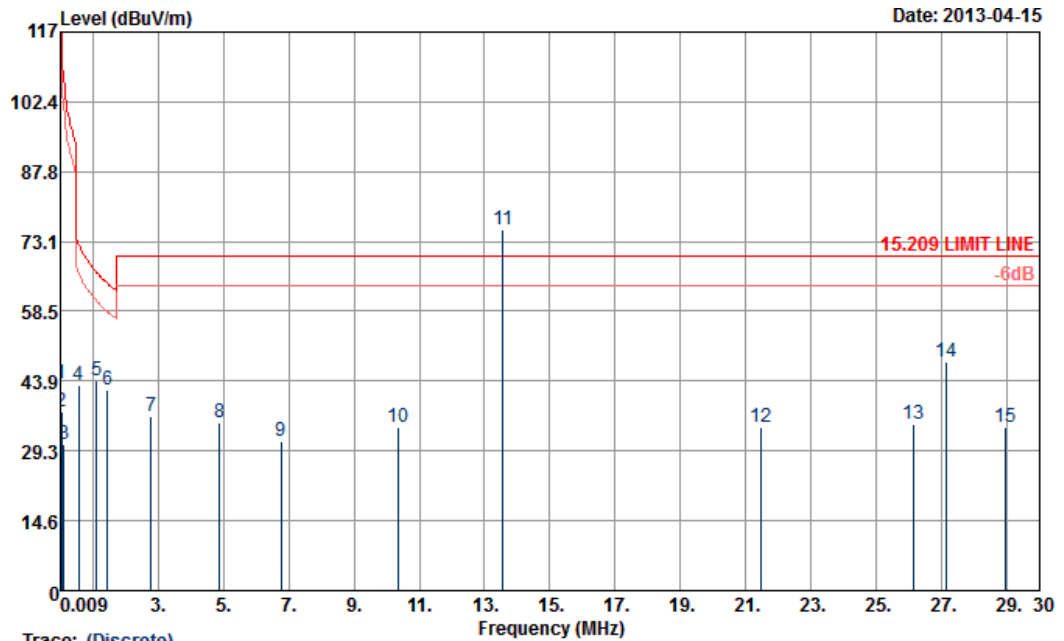

Trace: (Discrete)  
 Site : 03CH07-HY  
 Condition : 15.209 LIMIT LINE 3m NFC FACTOR(120912)-V VERTICAL  
 Project : FR 202101-01  
 Mode : 1

	Freq	Level	Over Limit	Limit Line	ReadAntenna Level	Antenna Factor	Cable Loss	Preamp Loss	A/Pos	T/Pos	Remark
	MHz	dBuV/m	dB	dBuV/m	dBuV	dB/m	dB	dB	cm	deg	
1	0.02	43.26	-79.30	122.56	22.71	20.26	0.29	0.00	---	---	QP
2	0.05	37.39	-76.53	113.92	16.93	20.17	0.29	0.00	---	---	QP
3	0.12	30.48	-75.80	106.28	10.13	20.06	0.29	0.00	---	---	QP
4	0.57	43.07	-29.45	72.52	22.76	20.00	0.31	0.00	---	---	QP
5	1.11	43.91	-22.76	66.67	23.60	20.00	0.31	0.00	---	---	QP
6	1.45	42.00	-22.41	64.41	21.68	20.01	0.31	0.00	---	---	QP
7	2.78	36.39	-33.61	70.00	16.02	20.03	0.34	0.00	---	---	QP
8	4.87	35.06	-34.94	70.00	14.73	19.97	0.36	0.00	---	---	QP
9	6.76	31.29	-38.71	70.00	11.06	19.86	0.37	0.00	---	---	QP
10	10.36	34.32	-35.68	70.00	14.16	19.77	0.39	0.00	---	---	QP
11 *	13.56	75.64			55.49	19.75	0.40	0.00	---	---	QP
12	21.48	34.29	-35.71	70.00	13.59	20.27	0.43	0.00	---	---	QP
13	26.15	34.85	-35.15	70.00	13.98	20.40	0.47	0.00	---	---	QP
14	27.12	47.83	-22.17	70.00	26.97	20.38	0.48	0.00	---	---	QP
15	28.94	34.35	-35.65	70.00	13.60	20.24	0.51	0.00	---	---	QP

Note:

1. Remark 11 is transmitter's fundamental signal.
2. The amplitude of spurious emissions which are attenuated by more than 20dB below the permissible value has no need to be reported.

Distance extrapolation factor = 40 log (specific distance / test distance) (dB);

Limit line = specific limits (dBuV) + distance extrapolation factor.



3.4.8 Results for Radiated Emissions (30MHz~1GHz)

Final Test Date	Apr. 15, 2013	Test Site No.	03CH07-HY
Temperature	22~24°C	Humidity	51~53%
Test Engineer	Beer Chang	Configurations	Ch.1

Horizontal

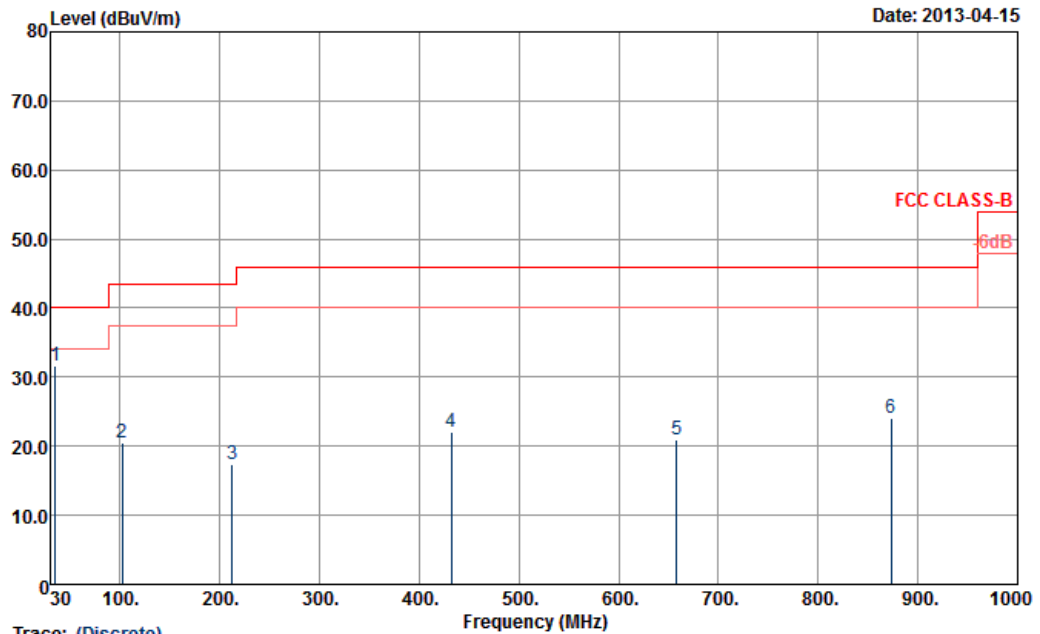

Trace: (Discrete)

Site : 03CH07-HY  
 Condition : FCC CLASS-B 3m LF-ANT(111116) HORIZONTAL  
 Project : FR 202101-01  
 Mode : 1

	Freq	Level	Over	Limit	ReadAntenna	Cable	Preamp	A/Pos	T/Pos	Remark
	MHz	dBuV/m	Limit	Line	Level	Loss	Factor	cm	deg	
			dB	dBuV/m	dBuV	dB	dB			
1	35.13	31.73	-8.27	40.00	46.63	16.40	0.58 31.88	133	159	QP
2	102.36	20.41	-23.09	43.50	41.01	10.07	1.01 31.68	---	---	QP
3	212.52	17.41	-26.09	43.50	37.42	9.98	1.37 31.36	---	---	QP
4	432.30	21.99	-24.01	46.00	34.23	16.69	2.25 31.18	---	---	QP
5	657.70	21.00	-25.00	46.00	28.25	20.26	2.86 30.37	---	---	QP
6	873.30	24.16	-21.84	46.00	28.70	22.83	3.30 30.67	---	---	QP



Vertical

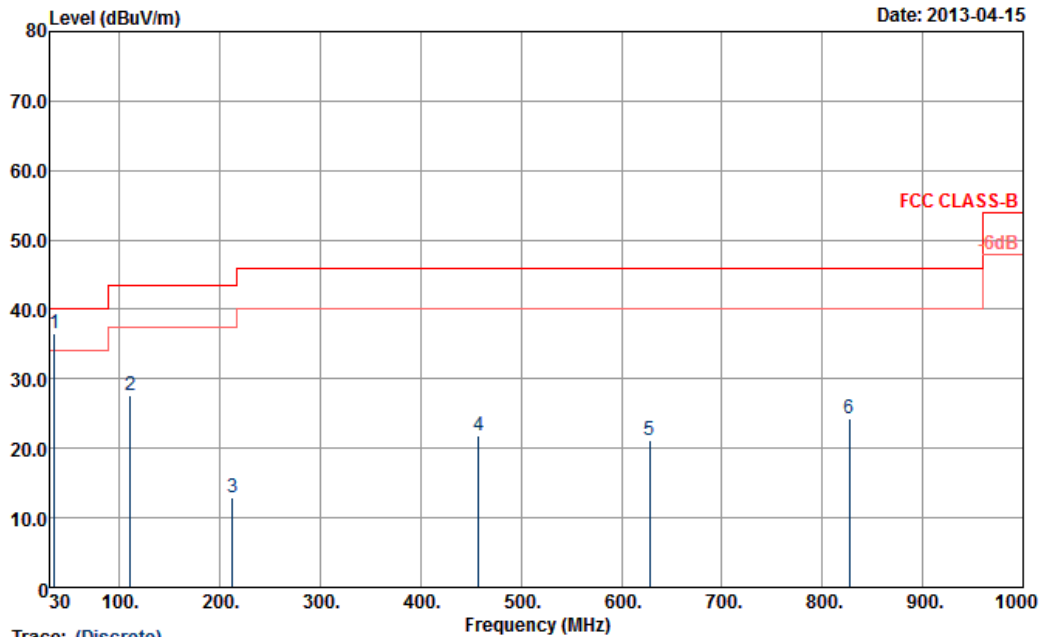

Trace: (Discrete)

Site : 03CH07-HY  
 Condition : FCC CLASS-B 3m LF-ANT(111116) VERTICAL  
 Project : FR 202101-01  
 Mode : 1

	Freq	Level	Over	Limit	ReadAntenna	Cable	Preamp	A/Pos	T/Pos	Remark
	MHz	dBuV/m	dB	dBuV/m	dBuV	dB	dB	cm	deg	
1	35.13	36.52	-3.48	40.00	51.42	16.40	0.58 31.88	122	148	QP
2	110.46	27.63	-15.87	43.50	47.53	10.80	1.05 31.75	---	---	QP
3	212.52	12.97	-30.53	43.50	32.98	9.98	1.37 31.36	---	---	QP
4	457.50	21.93	-24.07	46.00	33.56	17.21	2.32 31.16	---	---	QP
5	627.60	21.10	-24.90	46.00	28.74	20.02	2.77 30.43	---	---	QP
6	827.10	24.25	-21.75	46.00	29.04	22.37	3.21 30.37	---	---	QP

Note:

The amplitude of spurious emissions which are attenuated by more than 20dB below the permissible value has no need to be reported.

Emission level (dBμV/m) = 20 log Emission level (μV/m).

Corrected Reading: Antenna Factor + Cable Loss + Read Level - Preamp Factor= Level.



### 3.5 Frequency Stability Measurement

#### 3.5.1 Limit

The frequency tolerance of the carrier signal shall be maintained within +/- 0.01% (100ppm) of the operating frequency over a temperature variation of -20 degrees to +50 degrees C at normal supply voltage, and for a variation in the primary supply voltage from 85% to 115% of the rated supply voltage at a temperature of 20 degrees C. For battery operated equipment, the equipment tests shall be performed using a new battery.

#### 3.5.2 Measuring Instruments and Setting

Please refer to section 4 of equipments list in this report. The following table is the setting of the spectrum analyzer.

Spectrum Parameter	Setting
Attenuation	Auto
Span Frequency	Entire absence of modulation emissions bandwidth
RB	1 kHz
VB	3 kHz
Sweep Time	Auto

#### 3.5.3 Test Procedures

1. The transmitter output (antenna port) was connected to the spectrum analyzer.
2. EUT have transmitted absence of modulation signal and fixed channelize.
3. Set the spectrum analyzer span to view the entire absence of modulation emissions bandwidth.
4. Set RBW = 1 kHz, VBW = 3 kHz with peak detector and maxhold settings.
5. fc is declaring of channel frequency. Then the frequency error formula is  $(f_c - f) / f_c \times 10^6$  ppm and the limit is less than  $\pm 100$ ppm.
6. The test extreme voltage is to change the primary supply voltage from 85 to 115 percent of the nominal value
7. Extreme temperature rule is -20°C~50°C.

### 3.5.4 Test Setup Layout

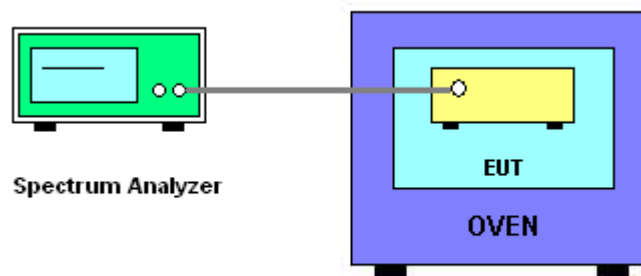

### 3.5.5 Test Deviation

There is no deviation with the original standard.

### 3.5.6 EUT Operation during Test

The EUT was programmed to be in continuously un-modulation transmitting mode.



3.5.7 Test Result of Frequency Stability

<b>Final Test Date</b>	Apr. 12, 2013	<b>Test Site No.</b>	TH02-HY
<b>Temperature</b>	22~24°C	<b>Humidity</b>	53~55%
<b>Test Engineer</b>	Tommy Lee	<b>Configurations</b>	Ch. 1

Voltage vs. Frequency Stability

Voltage(V)	Measurement Frequency (MHz)
120	13.55982
102	13.55984
138	13.55983
Max. Deviation (MHz)	-0.00016
Max. Deviation (ppm)	-11.7994

Temperature vs. Frequency Stability

Temperature (°C)	Measurement Frequency (MHz)
-20	13.55986
-10	13.55986
0	13.55986
10	13.55986
20	13.55986
30	13.55984
40	13.55984
50	13.55984
Max. Deviation (MHz)	-0.00014
Max. Deviation (ppm)	-10.3245



## **3.6 Antenna Requirements**

### **3.6.1 Limit**

Except for special regulations, the Low-power Radio-frequency Devices must not be equipped with any jacket for installing an antenna with extension cable. An intentional radiator shall be designed to ensure that no antenna other than that furnished by the responsible party shall be used with the device. The use of a permanently attached antenna or of an antenna that uses a unique coupling to the intentional radiator shall be considered sufficient to comply with the provisions of this Section. The manufacturer may design the unit so that the user can replace a broken antenna, but the use of a standard antenna jack or electrical connector is prohibited.

### **3.6.2 Antenna Connector Construction**

Embedded in Antenna.



### 4. LIST OF MEASURING EQUIPMENT

Instrument	Manufacturer	Model No.	Serial No.	Characteristics	Calibration Date	Test Date	Due Date	Remark
EMI Test Receiver	Rohde & Schwarz	ESCS 30	100356	9KHz – 2.75GHz	Nov. 13, 2012	Apr. 16, 2013	Nov. 12, 2013	Conduction (CO05-HY)
Two-LISN	Rohde & Schwarz	ENV216	100081	9KHz ~ 30MHz	Dec. 12, 2012	Apr. 16, 2013	Dec. 11, 2013	Conduction (CO05-HY)
Two-LISN	Rohde & Schwarz	ENV216	100080	9KHz ~ 30MHz	Dec. 06, 2012	Apr. 16, 2013	Dec. 05, 2013	Conduction (CO05-HY)
AC Power Source	APC	APC-1000W	N/A	N/A	N/A	Apr. 16, 2013	N/A	Conduction (CO05-HY)
System Simulator	R&S	CMU200	117995	N/A	Jul. 28, 2011	Apr. 16, 2013	Jul. 27, 2013	Conduction (CO05-HY)
GPS Station	T&E	GS-50	N/A	N/A	N/A	Apr. 16, 2013	N/A	Conduction (CO05-HY)
Spectrum Analyzer	R&S	FSP40	100055	9kHz~40GHz	Jun. 06, 2012	Apr. 12, 2013	Jun. 05, 2013	Conducted (TH02-HY)
Thermal Chamber	Ten Billion	TTH-D3SP	TBN-930701	N/A	Jul. 23, 2012	Apr. 12, 2013	Jul. 22, 2013	Conducted (TH02-HY)
Bilog Antenna	Schaffner	CBL6111C	2726	30MHz ~ 1GHz	Oct. 06, 2012	Apr. 15 2013	Oct. 05, 2013	Radiation (03CH07-HY)
Spectrum Analyzer	Rohde & Schwarz	FSP30	101067	9KHz ~ 30GHz	Nov. 30, 2012	Apr. 15 2013	Nov. 29, 2013	Radiation (03CH07-HY)
Preamplifier	COM-POWER	PA-103A	161241	10-1000MHz. 32dB.GAIN	Feb. 26, 2013	Apr. 15 2013	Feb. 25, 2014	Radiation (03CH07-HY)
EMI Test Receiver	Rohde & Schwarz	ESCI 7	100724	9kHz~7GHz	Sep. 03, 2012	Apr. 15 2013	Sep. 02, 2013	Radiation (03CH07-HY)
Loop Antenna	R&S	HFH2-Z2	860004/001	9KHz ~ 30MHz	Jul. 03, 2012	Apr. 15 2013	Jul. 02, 2013	Radiation (03CH07-HY)



## 5. TEST LOCATION

SHIJR	ADD : 6Fl., No. 106, Sec. 1, Shintai 5th Rd., Shijr City, Taipei, Taiwan 221, R.O.C. TEL : 886-2-2696-2468 FAX : 886-2-2696-2255
HWA YA	ADD : No. 52, Hwa Ya 1st Rd., Kwei-Shan Hsiang, Tao Yuan Hsien, Taiwan, R.O.C. TEL : 886-3-327-3456 FAX : 886-3-318-0055
LINKOU	ADD : No. 30-2, Dingfu Tsuen, Linkou Shiang, Taipei, Taiwan 244, R.O.C TEL : 886-2-2601-1640 FAX : 886-2-2601-1695
DUNGHU	ADD : No. 3, Lane 238, Kangle St., Neihu Chiu, Taipei, Taiwan 114, R.O.C. TEL : 886-2-2631-4739 FAX : 886-2-2631-9740
JUNGHE	ADD : 7Fl., No. 758, Jungjeng Rd., Junghe City, Taipei, Taiwan 235, R.O.C. TEL : 886-2-8227-2020 FAX : 886-2-8227-2626
NEIHU	ADD : 4Fl., No. 339, Hsin Hu 2 <sup>nd</sup> Rd., Taipei 114, Taiwan, R.O.C. TEL : 886-2-2794-8886 FAX : 886-2-2794-9777
JHUBEI	ADD : No.8, Lane 728, Bo-ai St., Jhubei City, HsinChu County 302, Taiwan, R.O.C. TEL : 886-3-656-9065 FAX : 886-3-656-9085
KUNSHAN	ADD : No. 3-2, PingXiang Road, Kunshan, Jiangsu Province, P.R.C. TEL : +86-0512-5790-0158 FAX : +86-0512-5790-0958

## 6. TAF CERTIFICATE OF ACCREDITATION



Certificate No. : L1190-130110

財團法人全國認證基金會  
Taiwan Accreditation Foundation

### Certificate of Accreditation

This is to certify that

**Sporton International Inc.**  
**EMC & Wireless Communications Laboratory**  
No.52, Hwa Ya 1st Rd., Hwa Ya Technology Park, Kwei-Shan Hsiang, Tao Yuan Hsien,  
Taiwan, R.O.C.

**is accredited in respect of laboratory**

<b>Accreditation Criteria</b>	: ISO/IEC 17025:2005
<b>Accreditation Number</b>	: 1190
<b>Originally Accredited</b>	: December 15, 2003
<b>Effective Period</b>	: January 10, 2013 to January 09, 2016
<b>Accredited Scope</b>	: Testing Field, see described in the Appendix
<b>Specific Accreditation Program</b>	: Accreditation Program for Designated Testing Laboratory for Commodities Inspection Accreditation Program for Telecommunication Equipment Testing Laboratory Accreditation Program for BSMI Mutual Recognition Arrangement with Foreign Authorities

  
Jay-San Chen  
President, Taiwan Accreditation Foundation  
Date: January 10, 2013

P1, total 20 pages



## **Appendix A. Photographs of EUT**

Please refer to Sporton report number EP202101-01 as below.