



# **CERTIFICATION TEST REPORT**

**Report Number. :** 11988954-E1V5

**Applicant :** Verifone, Inc.  
1400 West Stanford Ranch Road  
Rocklin, CA 95765, USA

**FCC ID :** B32V240M3GBW

**IC :** 787C-V240M3GBW

**EUT Description :** MOBILE POINT OF SALE TERMINAL  
**Model :** V240m 3GBW

**Test Standard(s) :** FCC CFR47 PART 22 SUBPART H (Radiated Emissions)  
FCC CFR47 PART 24 SUBPART E (Radiated Emissions)  
INDUSTRY CANADA RSS-132 ISSUE 3 (Radiated Emissions)  
INDUSTRY CANADA RSS-133 ISSUE 6 (Radiated Emissions)

**Date Of Issue:**

April 18, 2018

**Prepared by:**

UL Verification Services Inc.  
47173 Benicia Street  
Fremont, CA 94538, U.S.A.  
TEL: (510) 771-1000  
FAX: (510) 661-0888



### Revision History

Rev.	Issue Date	Revisions	Revised By
V1	12/06/17	Initial Issue	--
V2	02/19/18	Revised Scope of Testing section. Revised Test Methodology section. Updated Test & Measurement Equipment, section 7.	Frank Ibrahim
V3	03/02/18	Revised Test Methodology section. Revised EUT description. Added ERP/EIRP data. Revised scope of testing. Added additional data for EGPRS Rel 99 mode.	Frank Ibrahim
V4	03/05/18	Revised Output Power section. Revised IC number	Frank Ibrahim
V5	04/18/18	Added Worst-Case Configuration and Mode section. Updated Maximum Output Power section. Updated Scope of Testing section.	Frank Ibrahim

## TABLE OF CONTENTS

<b>1.</b>	<b>ATTESTATION OF TEST RESULTS .....</b>	<b>4</b>
<b>2.</b>	<b>TEST METHODOLOGY .....</b>	<b>5</b>
<b>3.</b>	<b>FACILITIES AND ACCREDITATION .....</b>	<b>5</b>
<b>4.</b>	<b>CALIBRATION AND UNCERTAINTY .....</b>	<b>5</b>
4.1.	<i>MEASURING INSTRUMENT CALIBRATION .....</i>	<i>5</i>
4.2.	<i>SAMPLE CALCULATION .....</i>	<i>5</i>
4.3.	<i>MEASUREMENT UNCERTAINTY.....</i>	<i>6</i>
<b>5.</b>	<b>EQUIPMENT UNDER TEST .....</b>	<b>7</b>
5.1.	<i>DESCRIPTION OF EUT .....</i>	<i>7</i>
5.2.	<i>MAXIMUM OUTPUT POWER.....</i>	<i>7</i>
5.2.1.	<i>MAXIMUM OUTPUT POWER (GSM/EGPRS).....</i>	<i>7</i>
5.2.2.	<i>MAXIMUM OUTPUT POWER (WCDMA) .....</i>	<i>8</i>
5.3.	<i>SCOPE OF TESTING.....</i>	<i>9</i>
5.4.	<i>DESCRIPTION OF AVAILABLE ANTENNAS .....</i>	<i>9</i>
5.5.	<i>WORST-CASE CONFIGURATION AND MODE.....</i>	<i>9</i>
5.6.	<i>DESCRIPTION OF TEST SETUP.....</i>	<i>10</i>
<b>6.</b>	<b>TEST AND MEASUREMENT EQUIPMENT .....</b>	<b>12</b>
<b>7.</b>	<b>SPURIOUS AND HARMONICS RADIATED TEST RESULTS.....</b>	<b>13</b>
<b>8.</b>	<b>SETUP PHOTOS .....</b>	<b>19</b>

# 1. ATTESTATION OF TEST RESULTS

**COMPANY NAME:** Verifone, Inc.  
1400 West Stanford Ranch Road Suite 200  
Rocklin, CA 95765, USA

**EUT DESCRIPTION:** Mobile Point of Sale Terminal

**MODEL:** V240m 3GBW

**SERIAL NUMBER:** 313-856-225

**DATE TESTED:** October 24, 2017

APPLICABLE STANDARDS	
STANDARD	TEST RESULTS
FCC PART 22H, 24E	PASS
INDUSTRY CANADA RSS-132,133	PASS

UL Verification Services Inc. tested the above equipment in accordance with the requirements set forth in the above standards. All indications of Pass/Fail in this report are opinions expressed by UL Verification Services Inc. based on interpretations and/or observations of test results. Measurement Uncertainties were not taken into account and are published for informational purposes only. The test results show that the equipment tested is capable of demonstrating compliance with the requirements as documented in this report.

Note: The results documented in this report apply only to the tested sample, under the conditions and modes of operation as described herein. This document may not be altered or revised in any way unless done so by UL Verification Services Inc. and all revisions are duly noted in the revisions section. Any alteration of this document not carried out by UL Verification Services Inc. will constitute fraud and shall nullify the document. This report must not be used by the client to claim product certification, approval, or endorsement by NVLAP, NIST, any agency of the Federal Government, or any agency of any government.

Approved & Released For  
UL Verification Services Inc. By: Prepared By:



FRANK IBRAHIM  
CONSUMER TECHNOLOGY DIVISION  
OPERATION LEADER  
UL VERIFICATION SERVICES INC



GLENN ESCANO  
CONSUMER TECHNOLOGY DIVISION  
LAB ENGINEER  
UL VERIFICATION SERVICES INC

## 2. TEST METHODOLOGY

The tests documented in this report were performed in accordance with ANSI/TIA-603-E-2016, FCC CFR 47 Part 2, FCC KDB 971168 D01 v03, FCC Part 22 and Part 24, RSS-132, RSS-133, and RSS-GEN Issue 4.

## 3. FACILITIES AND ACCREDITATION

The test sites and measurement facilities used to collect data are located at 47173 and 47266 Benicia Street, Fremont, California, USA. Line conducted emissions are measured only at the 47173 address. The following table identifies which facilities were utilized for radiated emission measurements documented in this report. Specific facilities are also identified in the test results sections.

47173 Benicia Street	47266 Benicia Street
<input type="checkbox"/> Chamber A(IC: 2324B-1)	<input type="checkbox"/> Chamber D(IC: 22541-1)
<input checked="" type="checkbox"/> Chamber B(IC: 2324B-2)	<input type="checkbox"/> Chamber E(IC: 22541-2)
<input type="checkbox"/> Chamber C(IC: 2324B-3)	<input type="checkbox"/> Chamber F(IC: 22541-3)
	<input type="checkbox"/> Chamber G(IC: 22541-4)
	<input type="checkbox"/> Chamber H(IC: 22541-5)

The above test sites and facilities are covered under FCC Test Firm Registration # 208313. UL Verification Services Inc. is accredited by NVLAP, Laboratory Code 200065-0. Chambers A through C are covered under Industry Canada company address code 2324B with site numbers 2324B -1 through 2324B-3, respectively. Chambers D through H are covered under Industry Canada company address code 22541 with site numbers 22541 -1 through 22541-5, respectively.

## 4. CALIBRATION AND UNCERTAINTY

### 4.1. MEASURING INSTRUMENT CALIBRATION

The measuring equipment utilized to perform the tests documented in this report has been calibrated in accordance with the manufacturer's recommendations, and is traceable to recognized national standards

### 4.2. SAMPLE CALCULATION

Where relevant, the following sample calculation is provided:

EIRP = PSA reading with EUT worst orientation (dBm) + Path loss (dB) – cable loss( between the SG and substitution antenna) + Substitution Antenna Factor (dBi)

ERP = PSA reading with EUT worst orientation (dBm) + Path loss (dB) – cable loss( between the SG and substitution antenna)

(Path loss = Signal generator output – PSA reading with substitution antenna)

### 4.3. MEASUREMENT UNCERTAINTY

Where relevant, the following measurement uncertainty levels have been estimated for tests performed on the apparatus:

PARAMETER	UNCERTAINTY
Occupied Channel Bandwidth	±1.1 %
RF output power, conducted	±0.35 dB
Power Spectral Density, conducted	±0.39 dB
Unwanted Emissions, conducted	±2.9 dB
All emissions, radiated	±5.36 dB
Temperature	±0.9 °C
Humidity	±2.26% RH
Supply Voltages	±0.45 %
Time	±0.2 %

Uncertainty figures are valid to a confidence level of 95%.

## 5. EQUIPMENT UNDER TEST

### 5.1. DESCRIPTION OF EUT

The EUT is a Point of Sale Terminal, which supports the following technologies WLAN 2.4 GHz, Bluetooth, GSM 850 / GSM 1900, WCDMA Band II / WCDMA Band V, and NFC.

### 5.2. MAXIMUM OUTPUT POWER

#### 5.2.1. MAXIMUM OUTPUT POWER (GSM/EGPRS)

The transmitter has a maximum peak conducted and ERP / EIRP output powers as follows:

FCC Part 22/24						
Band	Frequency Range(MHz)	Modulation	Conducted (Average)		ERP/EIRP (Average)	
			AVG(dBm)	AVG(mW)	dBm	mW
850	824~849	GPRS	31.65	1462.18	27.50	562.34
	824~849	EGPRS	26.00	398.11	21.85	153.11
1900	1850~1910	GPRS	28.78	755.09	30.28	1066.60
	1850~1910	EGPRS	24.80	302.00	26.30	426.58

RSS 132/133						
Band	Frequency Range(MHz)	Modulation	Conducted (Average)		EIRP (Average)	
			AVG(dBm)	AVG(mW)	dBm	mW
850	824~849	GPRS	31.65	1462.18	29.65	922.57
	824~849	EGPRS	26.00	398.11	24.00	251.19
1900	1850~1910	GPRS	28.78	755.09	30.28	1066.60
	1850~1910	EGPRS	24.80	302.00	26.30	426.58

### 5.2.2. MAXIMUM OUTPUT POWER (WCDMA)

The transmitter has a maximum peak conducted and ERP / EIRP output powers as follows:

FCC Part 24 & RSS 133						
Band	Frequency Range(MHz)	Modulation	Conducted (Average)		EIRP (Average)	
			AVG(dBm)	AVG(mW)	dBm	mW
Band 2	1850~1910	REL99	22.30	169.8	21.65	146.2
	1850~1910	HSDPA	22.72	187.1	22.07	161.1

FCC Part 22						
Band	Frequency Range(MHz)	Modulation	Conducted (Average)		ERP (Average)	
			AVG(dBm)	AVG(mW)	dBm	mW
Band 5	824~849	REL99	22.82	191.4	18.67	73.6
	824~849	HSDPA	21.46	140.0	17.31	53.8

RSS 132						
Band	Frequency Range(MHz)	Modulation	Conducted (Average)		EIRP (Average)	
			AVG(dBm)	AVG(mW)	dBm	mW
Band 5	824~849	REL99	22.82	191.4	20.82	120.8
	824~849	HSDPA	21.46	140.0	19.46	88.3



### 5.3. SCOPE OF TESTING

Model V240m 3GBW has the same WWAN radio module as model V240m Plus 3GBW that was tested and covered under report 11631998-E6V6 (FCC ID: B32V240MPLUS, IC: 787C- V240MPLUS).

For antenna port data (except ERP/EIRP) refer to report 11631998-E6V6. This report covers only radiated emissions for the following modes/bands:

- GSM GPRS 850 MHz
- GSM 1900 MHz ALLOCATED
- WCDMA HSDPA Band 2
- WCDMA HSDPA Band 5

ERP/EIRP is provided in this report. RF conducted output power was confirmed prior to making radiated spurious measurements.

Full radiated emissions testing was performed for V240m 3GBW model as covered by this report.

### 5.4. DESCRIPTION OF AVAILABLE ANTENNAS

The radio utilizes a PIFA antenna with a maximum peak gain as follow:

Frequency (MHz)	Peak Gain (dBi)
GSM850, 824~849MHz	-2.0
GSM1900, 1850~1910MHz	1.5
WCDMA Band 2, 1850~1910MHz	1.5
WCDMA Band 5, 824~849	-2.0

### 5.5. WORST-CASE CONFIGURATION AND MODE

The fundamental of the EUT was investigated in three orthogonal orientations X, Y, & Z, and it was determined that X-Axis was worst-case orientation; therefore, all final radiated testing was performed with the EUT in X-Axis.

## 5.6. DESCRIPTION OF TEST SETUP

### SUPPORT EQUIPMENT

Support Equipment List				
Description	Manufacturer	Model	Serial Number	FCC ID
AC Adapter	Verifone	SC1402	1708200053701	NA

### I/O CABLES (RADIATED SETUP)

I/O Cable List						
Cable No	Port	# of Identical ports	Connector Type	Serial Type	Cable Length (m)	Remarks
1	DC	1	Round	Un-shielded	1.75m	
2	RF In/out	1	Communication Test Set	Un-shielded	2m	

### TEST SETUP

The EUT is continuously communicated to the call box during the tests.

**SETUP DIAGRAM FOR TESTS (RADIATED TEST SETUP)**

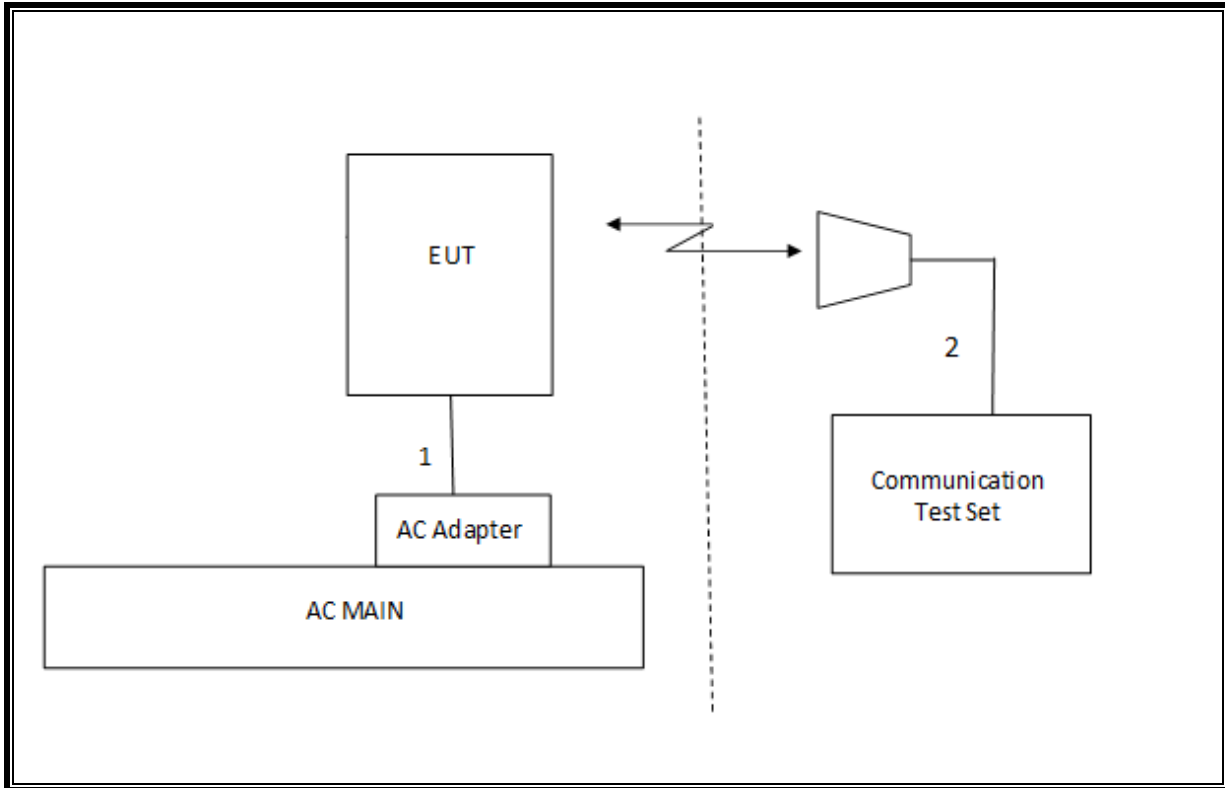

## 6. TEST AND MEASUREMENT EQUIPMENT

The following test and measurement equipment was utilized for the tests documented in this report:

Test Equipment List					
Description	Manufacturer	Model	T Number	Cal Date	Cal Due
Amplifier, 1 to 18 GHz	Miteq	AFS43-00101800-25-S-42	493	02/15/17	02/15/18
Amplifier, 1 to 8 GHz	Miteq	AMF-4D-01000800-30-29P	1156	02/15/17	02/15/18
Amplifier, 10KHz to 1GHz, 32dB	Keysight	8447D	10	02/15/17	02/15/18
Antenna, Broadband Hybrid, 30MHz to 2000MHz	Sunol Sciences	JB3	408	11/10/16	11/10/17
Horn Antenna	ETS-Lindgren	3117	T712	01/30/17	01/30/18
Spectrum Analyzer, PXA 3Hz to 44GHz	Keysight	N9030A	907	01/23/17	01/23/18
Highpass Filter, 2.7 GHz	Micro-Circuits	H2G518G6	T772	07/05/16	07/05/18
Highpass Filter, 1 GHz	Micro-Tronics	HPM18129	T889	02/21/17	02/21/18
Highpass Filter, 4GHz	Micro-Tronics	HPM13351	T1241	07/19/17	07/19/18
Wideband Radio Communication Tester	Rohde & Schwarz	CMW500	T956	06/22/17	06/22/18
PXA, Signal Analyzer	Agilent Technologies	N9030A	T1931	06/06/17	06/06/18
DC power supply, 8 V @ 3 A or 15 V @ 2 A	Agilent / HP	E3610A	None	CNR	None
Antenna, Tuned Dipole 400~1000 MHz	ETS	3121C DB4	T273	06/08/17	06/08/18
Directional Coupler	Mini-Circuits	ZUDC10-183+	T1136	06/18/17	06/18/18

Test Equipment List			
Description	Manufacturer	Model	UL Test software
Radiated Software	UL	UL EMC	Ver 1.2.4, Mar 13, 2017
Conducted Software	UL	UL EMC	Ver 9.5, May 26, 2015
CLT Software	UL	UL RF	Ver 1.7, Feb 2, 2015
Antenna Port Software	UL	UL RF	Ver 7.0.1, Feb 27, 2017

## 7. SPURIOUS AND HARMONICS RADIATED TEST RESULTS

### RULE PART(S)

FCC: §2.1053, §22.917  
IC: RSS132§5.5; RSS133§6.5

### FCC LIMIT

§22.917 (e) and §24.238 (a):

The power of any emission outside of the authorized operating frequency ranges must be attenuated below the transmitting power (P) by a factor of at least  $43 + 10 \log(P)$  dB.

#### RSS132§5.5

Mobile and base station equipment shall comply with the limits in (i) and (ii) below.

In the first 1.0 MHz band immediately outside and adjacent to each of the sub-bands specified in Section 5.1, the power of emissions per any 1% of the occupied bandwidth shall be attenuated (in dB) below the transmitter output power P (dBW) by at least  $43 + 10 \log_{10}P$  (watts).

After the first 1.0 MHz immediately outside and adjacent to each of the sub-bands, the power of emissions in any 100 kHz bandwidth shall be attenuated (in dB) below the transmitter output power P (dBW) by at least  $43 + 10 \log_{10}P$  (watts). If the measurement is performed using 1% of the occupied bandwidth, power integration over 100 kHz is required.

#### RSS133§6.5

Equipment shall comply with the limits in (i) and (ii) below.

(i) In the 1.0 MHz bands immediately outside and adjacent to the equipment's operating frequency block, the emission power per any 1% of the emission bandwidth shall be attenuated (in dB) below the transmitter output power P (dBW) by at least  $43 + 10 \log_{10}P$  (watts).

(ii) After the first 1.0 MHz, the emission power in any 1 MHz bandwidth shall be attenuated (in dB) below the transmitter output power P (dBW) by at least  $43 + 10 \log_{10}P$  (watts). If the measurement is performed using 1% of the emission bandwidth, power integration over 1.0 MHz is required.

### **TEST PROCEDURE**

For Cellular equipment - Compliance with these rules is based on the use of measurement instrumentation employing a resolution bandwidth of 100 kHz or greater. In the 1 MHz bands immediately outside and adjacent to the frequency block a resolution bandwidth of at least one percent of the emission bandwidth of the fundamental emission of the transmitter may be employed. A narrower resolution bandwidth is permitted in all cases to improve measurement accuracy provided the measured power is integrated over the full required measurement bandwidth (i.e. 100 kHz or 1 percent of emission bandwidth, as specified). The emission bandwidth is defined as the width of the signal between two points, one below the carrier center frequency and one above the carrier center frequency, outside of which all emissions are attenuated at least 26 dB below the transmitter power.

For PCS equipment - Compliance with these rules is based on the use of measurement instrumentation employing a resolution bandwidth of 1 MHz or greater. However, in the 1 MHz bands immediately outside and adjacent to the frequency block a resolution bandwidth of at least one percent of the emission bandwidth of the fundamental emission of the transmitter may be employed. A narrower resolution bandwidth is permitted in all cases to improve measurement accuracy provided the measured power is integrated over the full required measurement bandwidth (i.e. 1 MHz or 1 percent of emission bandwidth, as specified). The emission bandwidth is defined as the width of the signal between two points, one below the carrier center frequency and one above the carrier center frequency, outside of which all emissions are attenuated at least 26 dB below the transmitter power.

**GSM**

UL Verification Services, Inc. Above 1GHz High Frequency Substitution Measurement									
<b>Company:</b>		Verifone							
<b>Project #:</b>		11988954							
<b>Date:</b>		10/24/2017							
<b>Test Engineer:</b>		43575 OS							
<b>Configuration:</b>		EUT + AC Adapter							
<b>Location:</b>		Chamber B							
<b>Mode:</b>		GPRS 850 MHz Harmonics							
f MHz	SG reading (dBm)	Ant. Pol. (H/V)	Distance (m)	Preamp (dB)	Filter (dB)	EIRP (dBm)	Limit (dBm)	Delta (dB)	Notes
<b>Low Ch, 824.2MHz</b>									
1648.40	-20.1	V	3.0	37.0	1.0	-56.1	-13.0	-43.1	
2472.60	-23.5	V	3.0	36.4	1.0	-58.9	-13.0	-45.9	
3296.80	-21.2	V	3.0	36.2	1.0	-56.4	-13.0	-43.4	
1648.40	-14.7	H	3.0	37.0	1.0	-50.7	-13.0	-37.7	
2472.60	-24.1	H	3.0	36.4	1.0	-59.5	-13.0	-46.5	
3296.80	-21.5	H	3.0	36.2	1.0	-56.7	-13.0	-43.7	
<b>Mid Ch, 836.6MHz</b>									
1673.20	-16.5	V	3.0	37.0	1.0	-52.5	-13.0	-39.5	
2509.80	-21.2	V	3.0	36.4	1.0	-56.7	-13.0	-43.7	
3346.40	-21.1	V	3.0	36.1	1.0	-56.2	-13.0	-43.2	
1673.20	-17.1	H	3.0	37.0	1.0	-53.1	-13.0	-40.1	
2509.80	-23.6	H	3.0	36.4	1.0	-59.0	-13.0	-46.0	
3346.40	-21.2	H	3.0	36.1	1.0	-56.4	-13.0	-43.4	
<b>High Ch, 848.8MHz</b>									
1697.60	-18.6	V	3.0	37.0	1.0	-54.6	-13.0	-41.6	
2546.40	-22.9	V	3.0	36.4	1.0	-58.3	-13.0	-45.3	
3395.20	-20.9	V	3.0	36.1	1.0	-56.0	-13.0	-43.0	
1697.60	-14.9	H	3.0	37.0	1.0	-50.9	-13.0	-37.9	
2546.40	-24.3	H	3.0	36.4	1.0	-59.7	-13.0	-46.7	
3395.20	-21.3	H	3.0	36.1	1.0	-56.3	-13.0	-43.3	

**GSM850 GPRS**

UL Verification Services, Inc. Above 1GHz High Frequency Substitution Measurement									
<b>Company:</b>		Verifone							
<b>Project #:</b>		11988954							
<b>Date:</b>		10/24/2017							
<b>Test Engineer:</b>		43575 OS							
<b>Configuration:</b>		EUT + AC Adapter							
<b>Location:</b>		Chamber B							
<b>Mode:</b>		GPRS 1900 MHz Harmonics							
f MHz	SG reading (dBm)	Ant. Pol. (H/V)	Distance (m)	Preamp (dB)	Filter (dB)	EIRP (dBm)	Limit (dBm)	Delta (dB)	Notes
<b>Low Ch, 1850.2MHz</b>									
3700.40	-17.4	V	3.0	35.9	1.0	-52.2	-13.0	-39.2	
5550.60	-15.6	V	3.0	35.5	1.0	-50.1	-13.0	-37.1	
7400.80	-15.3	V	3.0	35.7	1.0	-50.0	-13.0	-37.0	
3700.40	-17.4	H	3.0	35.9	1.0	-52.3	-13.0	-39.3	
5550.60	-15.0	H	3.0	35.5	1.0	-49.5	-13.0	-36.5	
7400.80	-12.1	H	3.0	35.7	1.0	-46.9	-13.0	-33.9	
<b>Mid Ch, 1880MHz</b>									
3760.00	-17.4	V	3.0	35.8	1.0	-52.2	-13.0	-39.2	
5640.00	-16.1	V	3.0	35.5	1.0	-50.6	-13.0	-37.6	
7520.00	-15.4	V	3.0	35.7	1.0	-50.2	-13.0	-37.2	
3760.00	-17.4	H	3.0	35.8	1.0	-52.2	-13.0	-39.2	
5640.00	-15.1	H	3.0	35.5	1.0	-49.6	-13.0	-36.6	
7520.00	-13.1	H	3.0	35.7	1.0	-47.8	-13.0	-34.8	
<b>High Ch, 1909.8MHz</b>									
3819.60	-16.5	V	3.0	35.8	1.0	-51.3	-13.0	-38.3	
5729.40	-14.8	V	3.0	35.5	1.0	-49.3	-13.0	-36.3	
7639.20	-14.8	V	3.0	35.8	1.0	-49.6	-13.0	-36.6	
3819.60	-16.3	H	3.0	35.8	1.0	-51.1	-13.0	-38.1	
5729.40	-14.6	H	3.0	35.5	1.0	-49.1	-13.0	-36.1	
7639.20	-11.7	H	3.0	35.8	1.0	-46.5	-13.0	-33.5	

**GSM 1900 GPRS**

UL Verification Services, Inc. Above 1GHz High Frequency Substitution Measurement									
<b>Company:</b>		Verifone							
<b>Project #:</b>		11988954							
<b>Date:</b>		10/24/2017							
<b>Test Engineer:</b>		43575 OS							
<b>Configuration:</b>		EUT + AC Adapter							
<b>Location:</b>		Chamber B							
<b>Mode:</b>		EGPRS 850 MHz Harmonics							
f MHz	SG reading (dBm)	Ant. Pol. (H/V)	Distance (m)	Preamp (dB)	Filter (dB)	EIRP (dBm)	Limit (dBm)	Delta (dB)	Notes
<b>Low Ch, 824.2MHz</b>									
1648.40	-20.3	V	3.0	37.0	1.0	-56.4	-13.0	-43.4	
2472.60	-22.7	V	3.0	36.4	1.0	-58.1	-13.0	-45.1	
3296.80	-21.7	V	3.0	36.2	1.0	-56.9	-13.0	-43.9	
1648.40	-14.9	H	3.0	37.0	1.0	-51.0	-13.0	-38.0	
2472.60	-23.9	H	3.0	36.4	1.0	-59.3	-13.0	-46.3	
3296.80	-21.8	H	3.0	36.2	1.0	-57.0	-13.0	-44.0	
<b>Mid Ch, 836.6MHz</b>									
1673.20	-16.8	V	3.0	37.0	1.0	-52.8	-13.0	-39.8	
2509.80	-22.3	V	3.0	36.4	1.0	-57.7	-13.0	-44.7	
3346.40	-20.7	V	3.0	36.1	1.0	-55.8	-13.0	-42.8	
1673.20	-16.8	H	3.0	37.0	1.0	-52.8	-13.0	-39.8	
2509.80	-23.0	H	3.0	36.4	1.0	-58.4	-13.0	-45.4	
3346.40	-21.7	H	3.0	36.1	1.0	-56.8	-13.0	-43.8	
<b>High Ch, 848.8MHz</b>									
1697.60	-19.1	V	3.0	37.0	1.0	-55.0	-13.0	-42.0	
2546.40	-23.2	V	3.0	36.4	1.0	-58.6	-13.0	-45.6	
3395.20	-20.6	V	3.0	36.1	1.0	-55.7	-13.0	-42.7	
1697.60	-15.7	H	3.0	37.0	1.0	-51.7	-13.0	-38.7	
2546.40	-24.9	H	3.0	36.4	1.0	-60.3	-13.0	-47.3	
3395.20	-21.4	H	3.0	36.1	1.0	-56.5	-13.0	-43.5	

GSM850 EGPRS

UL Verification Services, Inc. Above 1GHz High Frequency Substitution Measurement									
<b>Company:</b>		Verifone							
<b>Project #:</b>		11988954							
<b>Date:</b>		10/24/2017							
<b>Test Engineer:</b>		43575 OS							
<b>Configuration:</b>		EUT + AC Adapter							
<b>Location:</b>		Chamber B							
<b>Mode:</b>		EGPRS 1900 MHz Harmonics							
f MHz	SG reading (dBm)	Ant. Pol. (H/V)	Distance (m)	Preamp (dB)	Filter (dB)	EIRP (dBm)	Limit (dBm)	Delta (dB)	Notes
<b>Low Ch, 1850.2MHz</b>									
3700.40	-17.2	V	3.0	35.9	1.0	-52.1	-13.0	-39.1	
5550.60	-15.3	V	3.0	35.5	1.0	-49.8	-13.0	-36.8	
7400.80	-15.1	V	3.0	35.7	1.0	-49.8	-13.0	-36.8	
3700.40	-16.6	H	3.0	35.9	1.0	-51.5	-13.0	-38.5	
5550.60	-14.8	H	3.0	35.5	1.0	-49.3	-13.0	-36.3	
7400.80	-12.0	H	3.0	35.7	1.0	-46.8	-13.0	-33.8	
<b>Mid Ch, 1880MHz</b>									
3760.00	-17.2	V	3.0	35.8	1.0	-52.0	-13.0	-39.0	
5640.00	-16.0	V	3.0	35.5	1.0	-50.5	-13.0	-37.5	
7520.00	-14.7	V	3.0	35.7	1.0	-49.4	-13.0	-36.4	
3760.00	-17.2	H	3.0	35.8	1.0	-52.1	-13.0	-39.1	
5640.00	-14.7	H	3.0	35.5	1.0	-49.2	-13.0	-36.2	
7520.00	-12.8	H	3.0	35.7	1.0	-47.6	-13.0	-34.6	
<b>High Ch, 1909.8MHz</b>									
3819.60	-16.4	V	3.0	35.8	1.0	-51.2	-13.0	-38.2	
5729.40	-15.0	V	3.0	35.5	1.0	-49.5	-13.0	-36.5	
7639.20	-13.8	V	3.0	35.8	1.0	-48.6	-13.0	-35.6	
3819.60	-16.8	H	3.0	35.8	1.0	-51.6	-13.0	-38.6	
5729.40	-15.1	H	3.0	35.5	1.0	-49.6	-13.0	-36.6	
7639.20	-11.9	H	3.0	35.8	1.0	-46.7	-13.0	-33.7	

GSM 1900 EGPRS



**WCDMA**

UL Verification Services, Inc. Above 1GHz High Frequency Substitution Measurement									
<b>Company:</b>		Verifone							
<b>Project #:</b>		11988954							
<b>Date:</b>		10/24/2017							
<b>Test Engineer:</b>		43575 OS							
<b>Configuration:</b>		EUT + AC Adapter							
<b>Location:</b>		Chamber B							
<b>Mode:</b>		HSDPA Band 2 Harmonics							
f MHz	SG reading (dBm)	Ant. Pol. (H/V)	Distance (m)	Preamp (dB)	Filter (dB)	EIRP (dBm)	Limit (dBm)	Delta (dB)	Notes
<b>Low Ch, 1852.4MHz</b>									
3704.80	-12.6	V	3.0	35.9	1.0	-47.4	-13.0	-34.4	
5557.20	-15.7	V	3.0	35.5	1.0	-50.2	-13.0	-37.2	
7409.60	-15.7	V	3.0	35.7	1.0	-50.4	-13.0	-37.4	
3704.80	-10.3	H	3.0	35.9	1.0	-45.2	-13.0	-32.2	
5557.20	-16.4	H	3.0	35.5	1.0	-50.9	-13.0	-37.9	
7409.60	-13.5	H	3.0	35.7	1.0	-48.2	-13.0	-35.2	
<b>Mid Ch, 1880MHz</b>									
3760.00	-14.6	V	3.0	35.8	1.0	-49.4	-13.0	-36.4	
5640.00	-15.8	V	3.0	35.5	1.0	-50.3	-13.0	-37.3	
7520.00	-15.0	V	3.0	35.7	1.0	-49.8	-13.0	-36.8	
3760.00	-14.9	H	3.0	35.8	1.0	-49.7	-13.0	-36.7	
5640.00	-14.2	H	3.0	35.5	1.0	-48.7	-13.0	-35.7	
7520.00	-14.0	H	3.0	35.7	1.0	-48.7	-13.0	-35.7	
<b>High Ch, 1907.6MHz</b>									
3815.20	-12.7	V	3.0	35.8	1.0	-47.4	-13.0	-34.4	
5722.80	-15.3	V	3.0	35.5	1.0	-49.8	-13.0	-36.8	
7630.40	-15.1	V	3.0	35.8	1.0	-49.8	-13.0	-36.8	
3815.20	-14.6	H	3.0	35.8	1.0	-49.4	-13.0	-36.4	
5722.80	-15.1	H	3.0	35.5	1.0	-49.6	-13.0	-36.6	
7630.40	-12.9	H	3.0	35.8	1.0	-47.7	-13.0	-34.7	

**B2 HSDPA**

UL Verification Services, Inc. Above 1GHz High Frequency Substitution Measurement									
<b>Company:</b>		Verifone							
<b>Project #:</b>		11988954							
<b>Date:</b>		10/24/2017							
<b>Test Engineer:</b>		43575 OS							
<b>Configuration:</b>		EUT + AC Adapter							
<b>Location:</b>		Chamber B							
<b>Mode:</b>		HSDPA Band 5 Harmonics							
f MHz	SG reading (dBm)	Ant. Pol. (H/V)	Distance (m)	Preamp (dB)	Filter (dB)	EIRP (dBm)	Limit (dBm)	Delta (dB)	Notes
<b>Low Ch, 826.4MHz</b>									
1652.80	-14.1	V	3.0	37.0	1.0	-50.1	-13.0	-37.1	
2479.20	-23.6	V	3.0	36.4	1.0	-59.0	-13.0	-46.0	
3305.60	-20.9	V	3.0	36.1	1.0	-56.0	-13.0	-43.0	
1652.80	-12.1	H	3.0	37.0	1.0	-48.1	-13.0	-35.1	
2479.20	-25.3	H	3.0	36.4	1.0	-60.8	-13.0	-47.8	
3305.60	-21.5	H	3.0	36.1	1.0	-56.7	-13.0	-43.7	
<b>Mid Ch, 836.6MHz</b>									
1673.20	-12.6	V	3.0	37.0	1.0	-48.6	-13.0	-35.6	
2509.80	-23.8	V	3.0	36.4	1.0	-59.2	-13.0	-46.2	
3346.40	-21.4	V	3.0	36.1	1.0	-56.5	-13.0	-43.5	
1673.20	-9.5	H	3.0	37.0	1.0	-45.5	-13.0	-32.5	
2509.80	-23.5	H	3.0	36.4	1.0	-58.9	-13.0	-45.9	
3346.40	-20.8	H	3.0	36.1	1.0	-55.9	-13.0	-42.9	
<b>High Ch, 846.6MHz</b>									
1693.20	-15.8	V	3.0	37.0	1.0	-51.8	-13.0	-38.8	
2539.80	-23.0	V	3.0	36.4	1.0	-58.4	-13.0	-45.4	
3386.40	-21.8	V	3.0	36.1	1.0	-56.8	-13.0	-43.8	
1693.20	-12.3	H	3.0	37.0	1.0	-48.3	-13.0	-35.3	
2539.80	-24.2	H	3.0	36.4	1.0	-59.6	-13.0	-46.6	
3386.40	-20.5	H	3.0	36.1	1.0	-55.6	-13.0	-42.6	

**B5 HSDPA**

**UL Verification Services, Inc.**  
**Above 1GHz High Frequency Substitution Measurement**

**Company:** Verifone  
**Project #:** 11988954  
**Date:** 10/24/2017  
**Test Engineer:** 43575 OS  
**Configuration:** EUT + AC Adapter  
**Location:** Chamber B  
**Mode:** Rel99 Band 2 Harmonics

f MHz	SG reading (dBm)	Ant. Pol. (H/V)	Distance (m)	Preamp (dB)	Filter (dB)	EIRP (dBm)	Limit (dBm)	Delta (dB)	Notes
<b>Low Ch, 1852.4MHz</b>									
3704.80	-13.2	V	3.0	35.9	1.0	-48.0	-13.0	-35.0	
5557.20	-15.4	V	3.0	35.5	1.0	-49.9	-13.0	-36.9	
7409.60	-15.0	V	3.0	35.7	1.0	-49.8	-13.0	-36.8	
3704.80	-9.8	H	3.0	35.9	1.0	-44.6	-13.0	-31.6	
5557.20	-16.3	H	3.0	35.5	1.0	-50.8	-13.0	-37.8	
7409.60	-12.3	H	3.0	35.7	1.0	-47.1	-13.0	-34.1	
<b>Mid Ch, 1880MHz</b>									
3760.00	-14.9	V	3.0	35.8	1.0	-49.7	-13.0	-36.7	
5640.00	-16.2	V	3.0	35.5	1.0	-50.7	-13.0	-37.7	
7520.00	-14.7	V	3.0	35.7	1.0	-49.5	-13.0	-36.5	
3760.00	-14.3	H	3.0	35.8	1.0	-49.2	-13.0	-36.2	
5640.00	-14.2	H	3.0	35.5	1.0	-48.7	-13.0	-35.7	
7520.00	-13.2	H	3.0	35.7	1.0	-47.9	-13.0	-34.9	
<b>High Ch, 1907.6MHz</b>									
3815.20	-13.3	V	3.0	35.8	1.0	-48.1	-13.0	-35.1	
5722.80	-15.4	V	3.0	35.5	1.0	-49.9	-13.0	-36.9	
7630.40	-14.9	V	3.0	35.8	1.0	-49.6	-13.0	-36.6	
3815.20	-14.6	H	3.0	35.8	1.0	-49.3	-13.0	-36.3	
5722.80	-14.8	H	3.0	35.5	1.0	-49.3	-13.0	-36.3	
7630.40	-12.9	H	3.0	35.8	1.0	-47.6	-13.0	-34.6	

**B2 Rel99**

**UL Verification Services, Inc.**  
**Above 1GHz High Frequency Substitution Measurement**

**Company:** Verifone  
**Project #:** 11988954  
**Date:** 10/24/2017  
**Test Engineer:** 43575 OS  
**Configuration:** EUT + AC Adapter  
**Location:** Chamber B  
**Mode:** Rel99 Band 5 Harmonics

f MHz	SG reading (dBm)	Ant. Pol. (H/V)	Distance (m)	Preamp (dB)	Filter (dB)	EIRP (dBm)	Limit (dBm)	Delta (dB)	Notes
<b>Low Ch, 826.4MHz</b>									
1652.80	-14.7	V	3.0	37.0	1.0	-50.7	-13.0	-37.7	
2479.20	-22.4	V	3.0	36.4	1.0	-57.9	-13.0	-44.9	
3305.60	-21.7	V	3.0	36.1	1.0	-56.9	-13.0	-43.9	
1652.80	-12.3	H	3.0	37.0	1.0	-48.3	-13.0	-35.3	
2479.20	-25.5	H	3.0	36.4	1.0	-61.0	-13.0	-48.0	
3305.60	-22.1	H	3.0	36.1	1.0	-57.3	-13.0	-44.3	
<b>Mid Ch, 836.6MHz</b>									
1673.20	-12.9	V	3.0	37.0	1.0	-48.9	-13.0	-35.9	
2509.80	-24.0	V	3.0	36.4	1.0	-59.4	-13.0	-46.4	
3346.40	-22.2	V	3.0	36.1	1.0	-57.3	-13.0	-44.3	
1673.20	-10.1	H	3.0	37.0	1.0	-46.1	-13.0	-33.1	
2509.80	-24.9	H	3.0	36.4	1.0	-60.3	-13.0	-47.3	
3346.40	-21.2	H	3.0	36.1	1.0	-56.3	-13.0	-43.3	
<b>High Ch, 846.6MHz</b>									
1693.20	-15.5	V	3.0	37.0	1.0	-51.4	-13.0	-38.4	
2539.80	-23.3	V	3.0	36.4	1.0	-58.7	-13.0	-45.7	
3386.40	-22.2	V	3.0	36.1	1.0	-57.3	-13.0	-44.3	
1693.20	-12.8	H	3.0	37.0	1.0	-48.8	-13.0	-35.8	
2539.80	-24.8	H	3.0	36.4	1.0	-60.2	-13.0	-47.2	
3386.40	-21.1	H	3.0	36.1	1.0	-56.2	-13.0	-43.2	

**B5 Rel99**