



CERTIFICATION TEST REPORT

Report Number. : 11988954-E2V3

Applicant : Verifone, Inc.
1400 West Stanford Ranch Road
Rocklin, CA 95765, USA

Model : V240m 3GBW

FCC ID : B32V240M3GBW

IC : 787C-V240M3GBW

EUT Description : Mobile Point of Sale Terminal

Test Standard(s) : **FCC 47 CFR Part 15C**
ICE-RSS-210 Issue 9, Annex B
ICE-RSS-GEN Issue 4

Date Of Issue:

February 28, 2018

Prepared by:

UL Verification Services Inc.
47173 Benicia Street
Fremont, CA 94538, U.S.A.
TEL: (510) 771-1000
FAX: (510) 661-0888



NVLAP Lab code: 200246-0

Revision History

<u>Ver.</u>	<u>Issue Date</u>	<u>Revisions</u>	<u>Revised By</u>
V1	10/24/17	Initial Issue	--
V2	01/30/18	Revised Worst-Case Configuration and Mode section.	Frank Ibrahim
V3	02/28/18	Revised Description of EUT. Added Scope of Testing section.	Frank Ibrahim

TABLE OF CONTENTS

1. ATTESTATION OF TEST RESULTS	4
2. TEST METHODOLOGY	6
3. FACILITIES AND ACCREDITATION	6
4. CALIBRATION AND UNCERTAINTY	7
4.1. <i>MEASURING INSTRUMENT CALIBRATION</i>	<i>7</i>
4.2. <i>SAMPLE CALCULATION</i>	<i>7</i>
4.3. <i>MEASUREMENT UNCERTAINTY.....</i>	<i>7</i>
5. EQUIPMENT UNDER TEST	8
5.1. <i>DESCRIPTION OF EUT</i>	<i>8</i>
5.2. <i>SCOPE OF TESTING.....</i>	<i>8</i>
5.3. <i>MAXIMUM FIELD STRENGTH.....</i>	<i>8</i>
5.4. <i>DESCRIPTION OF AVAILABLE ANTENNAS</i>	<i>8</i>
5.5. <i>SOFTWARE AND FIRMWARE.....</i>	<i>8</i>
5.6. <i>WORST-CASE CONFIGURATION AND MODE.....</i>	<i>9</i>
5.7. <i>MODIFICATIONS</i>	<i>9</i>
5.8. <i>DESCRIPTION OF TEST SETUP.....</i>	<i>10</i>
6. TEST AND MEASUREMENT EQUIPMENT	12
7. RADIATED EMISSION TEST RESULTS.....	13
7.1. <i>LIMITS AND PROCEDURE.....</i>	<i>13</i>
7.2. <i>FUNDAMENTAL AND FUNDAMENTAL EMISSION MASK (11.56 – 15.56 MHz).....</i>	<i>15</i>
7.3. <i>TX SPURIOUS EMISSIONS (0.09 – 30MHz).....</i>	<i>17</i>
7.4. <i>TX SPURIOUS EMISSIONS (30 – 1000MHz).....</i>	<i>18</i>
8. SETUP PHOTOS.....	20

1. ATTESTATION OF TEST RESULTS

COMPANY NAME: Verifone, Inc.
1400 West Stanford Ranch Road Suite 200
Rocklin, CA 95765, USA

EUT DESCRIPTION: Mobile Point of Sale Terminal

MODEL: V240m 3GBW

SERIAL NUMBER: 313-856-706

DATE TESTED: October 19 to 20, 2017

APPLICABLE STANDARDS	
STANDARD	TEST RESULTS
FCC 47 CFR PART 15 SUBPART C	PASS
INDUSTRY CANADA RSS - 210 ISSUE 9	PASS
INDUSTRY CANADA RSS-GEN ISSUE 4	PASS

UL Verification Services Inc. tested the above equipment in accordance with the requirements set forth in the above standards. All indications of Pass/Fail in this report are opinions expressed by UL Verification Services Inc. based on interpretations and/or observations of test results. Measurement Uncertainties were not taken into account and are published for informational purposes only. The test results show that the equipment tested is capable of demonstrating compliance with the requirements as documented in this report.

Note: The results documented in this report apply only to the tested sample, under the conditions and modes of operation as described herein. This document may not be altered or revised in any way unless done so by UL Verification Services Inc. and all revisions are duly noted in the revisions section. Any alteration of this document not carried out by UL Verification Services Inc. will constitute fraud and shall nullify the document. This report must not be used by the client to claim product certification, approval, or endorsement by NVLAP, NIST, any agency of the Federal Government, or any agency of any government.

Approved & Released For
UL Verification Services Inc. By:



FRANK IBRAHIM
CONSUMER TECHNOLOGY DIVISION
OPERATION LEADER
UL VERIFICATION SERVICES INC

Prepared By:



GLENN ESCANO
CONSUMER TECHNOLOGY DIVISION
LAB ENGINEER
UL VERIFICATION SERVICES INC

2. TEST METHODOLOGY

The tests documented in this report were performed in accordance with ANSI C63.10-2013, FCC CFR 47 Part 2, and FCC CFR 47 Part 15, RSS-GEN Issue 4, and RSS-210 Issue 9.

3. FACILITIES AND ACCREDITATION

The test sites and measurement facilities used to collect data are located at 47173 and 47266 Benicia Street, Fremont, California, USA. Line conducted emissions are measured only at the 47173 address. The following table identifies which facilities were utilized for radiated emission measurements documented in this report. Specific facilities are also identified in the test results sections.

47173 Benicia Street	47266 Benicia Street
<input type="checkbox"/> Chamber A (IC:2324B-1)	<input type="checkbox"/> Chamber D (IC:22541-1)
<input checked="" type="checkbox"/> Chamber B (IC:2324B-2)	<input type="checkbox"/> Chamber E (IC: 22541-2)
<input type="checkbox"/> Chamber C (IC:2324B-3)	<input type="checkbox"/> Chamber F (IC: 22541-3)
	<input type="checkbox"/> Chamber G (IC: 22541-4)
	<input type="checkbox"/> Chamber H (IC: 22541-5)

The above test sites and facilities are covered under FCC Test Firm Registration # 208313. UL Verification Services Inc. is accredited by NVLAP, Laboratory Code 200065-0.

Chambers A through C are covered under Industry Canada company address code 2324B with site numbers 2324B -1 through 2324B-3, respectively and Chambers D through H are covered under Industry Canada company address code 22541 with site numbers 22541 -1 through 22541-5, respectively.

4. CALIBRATION AND UNCERTAINTY

4.1. MEASURING INSTRUMENT CALIBRATION

The measuring equipment utilized to perform the tests documented in this report has been calibrated in accordance with the manufacturer's recommendations, and is traceable to recognized national standards.

4.2. SAMPLE CALCULATION

Where relevant, the following sample calculation is provided:

$$\begin{aligned} \text{Field Strength (dBuV/m)} &= \text{Measured Voltage (dBuV)} + \text{Antenna Factor (dB/m)} + \\ &\text{Cable Loss (dB)} - \text{Preamp Gain (dB)} \\ 36.5 \text{ dBuV} + 18.7 \text{ dB/m} + 0.6 \text{ dB} - 26.9 \text{ dB} &= 28.9 \text{ dBuV/m} \end{aligned}$$

4.3. MEASUREMENT UNCERTAINTY

Where relevant, the following measurement uncertainty levels have been estimated for tests performed on the apparatus:

Parameter	Uncertainty
Worst Case Conducted Disturbance, 9KHz to 0.15 MHz	3.84 dB
Worst Case Conducted Disturbance, 0.15 to 30 MHz	3.65 dB
Worst Case Radiated Disturbance, 9KHz to 30 MHz	3.15 dB
Worst Case Radiated Disturbance, 30 to 1000 MHz	5.36 dB
Worst Case Radiated Disturbance, 1000 to 18000 MHz	4.32 dB
Worst Case Radiated Disturbance, 18000 to 26000 MHz	4.45 dB
Worst Case Radiated Disturbance, 26000 to 40000 MHz	5.24 dB

Uncertainty figures are valid to a confidence level of 95%.

5. EQUIPMENT UNDER TEST

5.1. DESCRIPTION OF EUT

The EUT is a Point of Sale Terminal, which supports the following technologies WLAN 2.4 GHz, Bluetooth, GSM 850 / GSM 1900, WCDMA Band II / WCDMA Band V, and NFC.

5.2. SCOPE OF TESTING

Only radiated testing was performed on this device for NFC as it has the same NFC module from base model V240m Plus 3GBW (FCC ID: B32V240MPLUS; IC: 787C-V240MPLUS) that was covered by report number "11631998-E5V2". Full radiated emission testing was performed. Results for this device was equal or lower than the results of the base model, therefor, not further testing or investigation is required.

For OBW, Frequency stability and AC line conducted emission, refer to Section 7, 9 and 10 of report "11631998-E5V2" related to FCC ID: B32V240MPLUS; IC: 787C-V240MPLUS

5.3. MAXIMUM FIELD STRENGTH

The testing was performed at 3 meter. The transmitter maximum E-field at 30 meter distance was 38.2 dBuV/m which was converted from the 3 meter data.

5.4. DESCRIPTION OF AVAILABLE ANTENNAS

The radio used a two turn, inductive loop antenna.

Gemalto M2M GmbH report: UL05420140826CE020-3/UL05420140826CE020-4 and tested by Unilab (Shanghai) Co., Ltd

5.5. SOFTWARE AND FIRMWARE

The firmware installed in the EUT during testing was VOS2 – 30640xxx.

5.6. WORST-CASE CONFIGURATION AND MODE

The fundamental of the EUT was investigated in three orthogonal orientations X, Y, Z, it was determined that X-Axis orientation was worst-case orientation; therefore, all final radiated testing was performed with the EUT in X-Axis orientation.

Only radiated testing was performed on this device for NFC as it has the same NFC module from base model V240m Plus 3GBW that was covered by report number "11631998-E5V1", enclosure of this device is different, therefore, full radiated emissions testing was performed. Results for this device was equal or lower than the results of the base model, therefore, no further testing or investigation is required.

For conducted test data which covers Frequency Tolerance and power line conducted emissions, refer to sections 9 and 10 of report "11631998-E5V1" related to FCC ID "B32V240MPLUS" and IC "787C-V240MPLUS".

5.7. MODIFICATIONS

No modifications were made during testing.

5.8. DESCRIPTION OF TEST SETUP

SUPPORT EQUIPMENT

Support Equipment List				
Description	Manufacturer	Model	Serial Number	FCC ID
Laptop	Lenovo	20B7S0A200	PC015REW	NA
AC Adapter	Verifone	SC1402	1713600062701	NA

I/O CABLES (RADIATED EMISSIONS)

I/O Cable List						
Cable No	Port	# of identical ports	Connector Type	Cable Type	Cable Length (m)	Remarks
1	DC	1	AC	Un-shielded	2	N/A

RADIATED EMISSIONS SETUP DIAGRAM

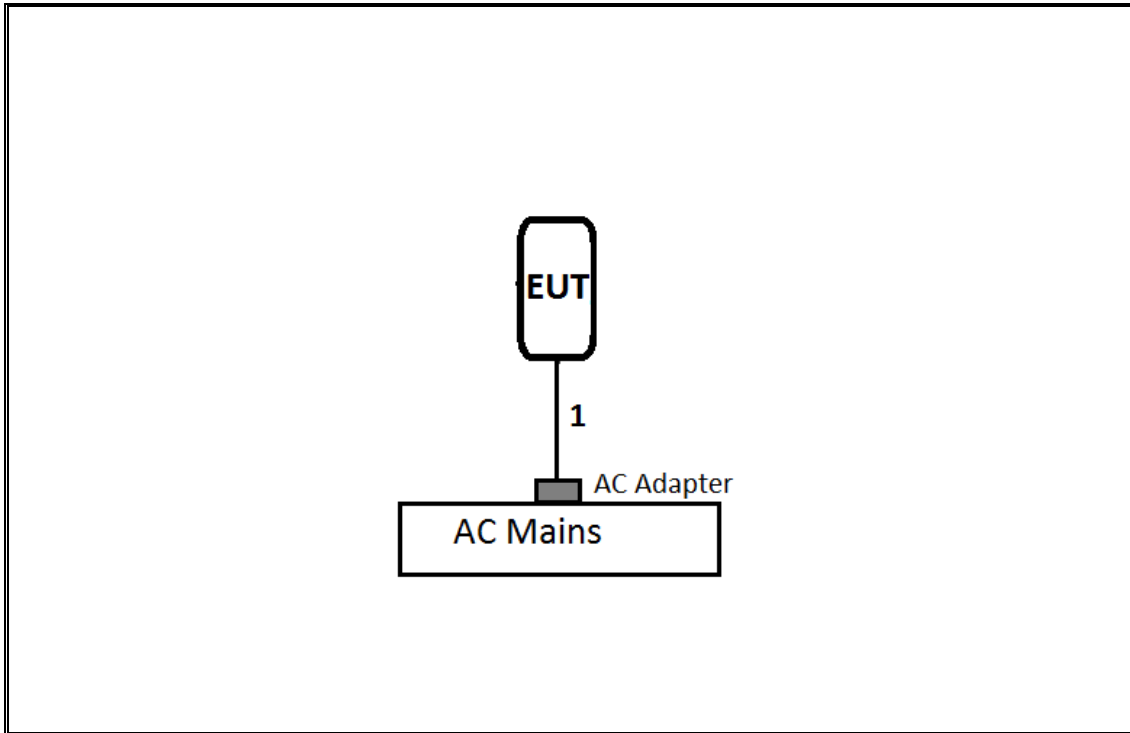

6. TEST AND MEASUREMENT EQUIPMENT

The following test and measurement equipment was utilized for the tests documented in this report:

TEST EQUIPMENT LIST				
Description	Manufacturer	Model	Asset	Cal Due
Antenna, Broadband Hybrid, 30MHz to 2000MHz w/4dB Pad	Sunol Sciences Corp.	JB3	T477	06/24/18
Antenna, Active Loop 9kHz-30MHz	ETS-Lindgren	6502	T1683	02/17/18
Amplifier, 10kHz-1GHz	Agilent (Keysight) Technologies	8447D	T15	08/24/18
Spectrum Analyzer, PXA, 3Hz to 44GHz	Agilent (Keysight) Technologies	N9030A	T907	01/23/18

NOTE: *testing is completed before equipment calibration expiration date.

Description	Manufacturer	Model	Version
Radiated Software	UL	UL EMC	Ver 9.5, Apr 26, 2016

7. RADIATED EMISSION TEST RESULTS

7.1. LIMITS AND PROCEDURE

LIMIT

§15.225, 15.209

IC RSS-210, Annex B.6 (Transmitter)

IC RSS-GEN, Section 7.1.2 (Receiver)

(a) The field strength of any emissions within the band 13.553–13.567 MHz shall not exceed 15,848 microvolts/ meter at 30 meters.

(b) Within the bands 13.410–13.553 MHz and 13.567–13.710 MHz, the field strength of any emissions shall not exceed 334 microvolts/meter at 30 meters.

(c) Within the bands 13.110–13.410 MHz and 13.710–14.010 MHz the field strength of any emissions shall not exceed 106 microvolts/meter at 30 meters.

(d) The field strength of any emissions appearing outside of the 13.110– 14.010 MHz and shall not exceed the general radiated emission limits in § 15.209 as follows:

§15.209 (a) Except as provided elsewhere in this subpart, the emissions from an intentional radiator shall not exceed the field strength levels specified in the following table:

Limits for radiated disturbance of an intentional radiator		
Frequency range (MHz)	Limits (µV/m)	Measurement Distance (m)
0.009 – 0.490	2400 / F (kHz)	300
0.490 – 1.705	24000 / F (kHz)	30
1.705 – 30.0	30	30
30 – 88	100**	3
88 - 216	150**	3
216 – 960	200**	3
Above 960	500	3

** Except as provided in paragraph (g), fundamental emissions from intentional radiators operating under this section shall not be located in the frequency bands 54-72 MHz, 76-88 MHz, 174-216 MHz or 470-806 MHz. However, operation within these frequency bands is permitted under other sections of this part, e.g. §§ 15.231 and 15.241.

§15.209 (b) In the emission table above, the tighter limit applies at the band edges.

Formula for converting the field strength from uV/m to dBuV/m is:

Limit (dBuV/m) = 20 log limit (uV/m)

§15.209 (d) The emission limits shown at the above table are based on measurements employing a CISPR quasi-peak detector except for the frequency bands 9-90 kHz, 110-490 kHz and above 1000 MHz. Radiated emissions limits in these three bands are based on measurements employing an average detector.

§15.209 (d) The provisions in §§ 15.225, measuring emissions at distances other than the distances specified in the above table, determining the frequency range over which radiated emissions are to be measured, and limiting peak emissions apply to all devices operated under this part.

TEST PROCEDURE

ANSI C63.10-2013

The EUT is an intentional radiator that incorporates a digital device. The highest fundamental frequency generated or used in the device is 13.56 MHz. The frequency range was investigated from 0.15 MHz to the 10th harmonic of the highest fundamental frequency, or 1000 MHz, whichever is greater (1000MHz)

RESULTS

KDB 414788 OATS and Chamber Correlation Justification

Base on FCC 15.31 (f) (2): measurements may be performed at a distance closer than that specified in the regulations; however, an attempt should be made to avoid making measurements in the near field.

OATs and chamber correlation testing had been performed and chamber measured test result is the worst case test result.

7.2. FUNDAMENTAL AND FUNDAMENTAL EMISSION MASK (11.56 – 15.56 MHz)

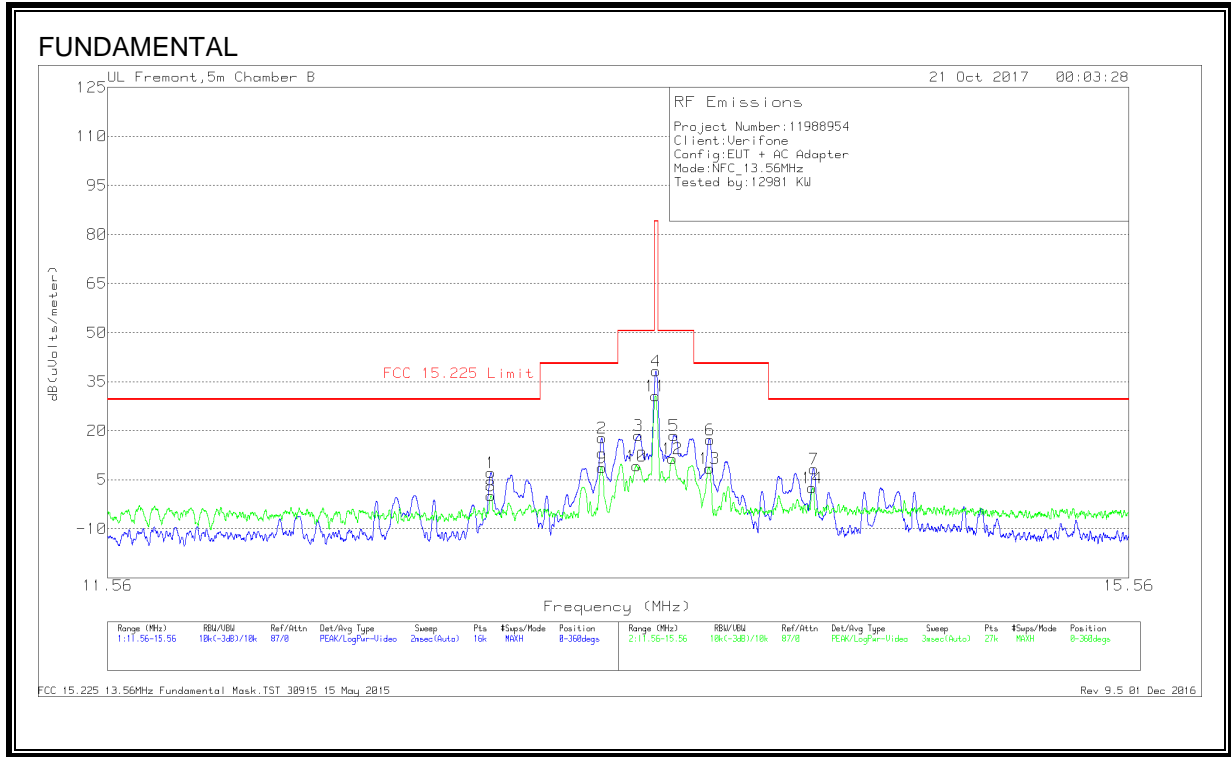

Trace Markers

Marker	Frequency (MHz)	Meter Reading (dBuV)	Det	Loop Antenna (dB/m)	Cbl (dB)	Dist Corr (dB) 40Log	Corrected Reading dB(uVolts/meter)	FCC 15.225 Limit	PK Margin (dB)	Azimuth (Degs)	Polarity
1	12.92438	34.81	Pk	10.7	1.6	-40	7.11	29.54	-22.43	0-360	Face-On
8	12.92449	27.86	Pk	10.7	1.6	-40	.16	29.54	-29.38	0-360	Face-Off
2	13.34775	45.45	Pk	10.7	1.6	-40	17.75	40.51	-22.76	0-360	Face-On
9	13.34799	36.4	Pk	10.7	1.6	-40	8.7	40.51	-31.81	0-360	Face-Off
10	13.48319	36.99	Pk	10.7	1.6	-40	9.29	50.5	-41.21	0-360	Face-Off
3	13.49	46.17	Pk	10.7	1.6	-40	18.47	50.5	-32.03	0-360	Face-On
11	*13.55807	58.4	Pk	10.6	1.6	-40	30.6	84	-53.4	0-360	Face-Off
4	*13.55975	66	Pk	10.6	1.6	-40	38.2	84	-45.8	0-360	Face-On
12	13.62601	39.18	Pk	10.6	1.6	-40	11.38	50.5	-39.12	0-360	Face-Off
5	13.63125	46.38	Pk	10.6	1.6	-40	18.58	50.5	-31.92	0-360	Face-On
13	13.7723	36.34	Pk	10.6	1.6	-40	8.54	40.51	-31.97	0-360	Face-Off
6	13.77425	44.96	Pk	10.6	1.6	-40	17.16	40.51	-23.35	0-360	Face-On
14	14.19129	30.31	Pk	10.6	1.6	-40	2.51	29.54	-27.03	0-360	Face-Off
7	14.197	36.07	Pk	10.6	1.6	-40	8.27	29.54	-21.27	0-360	Face-On

* - indicates fundamental frequency
 Pk - Peak detector

Fundamental Frequency

Frequency (MHz)	Meter Reading (dBuV)	Det	Loop Antenna (dB/m)	Cbl (dB)	Dist Corr 30m	Corrected Reading dB(uVolts/meter)	FCC 15.225 Limit	PK Margin (dB)	Azimuth (Degs)	Antenna Position
*13.55807	58.4	Pk	10.6	1.6	-40	30.6	84	-53.4	0-360	Face-Off
*13.55975	66	Pk	10.6	1.6	-40	38.2	84	-45.8	0-360	Face-On

Pk - Peak detector

7.3. TX SPURIOUS EMISSIONS (0.09 – 30MHz)

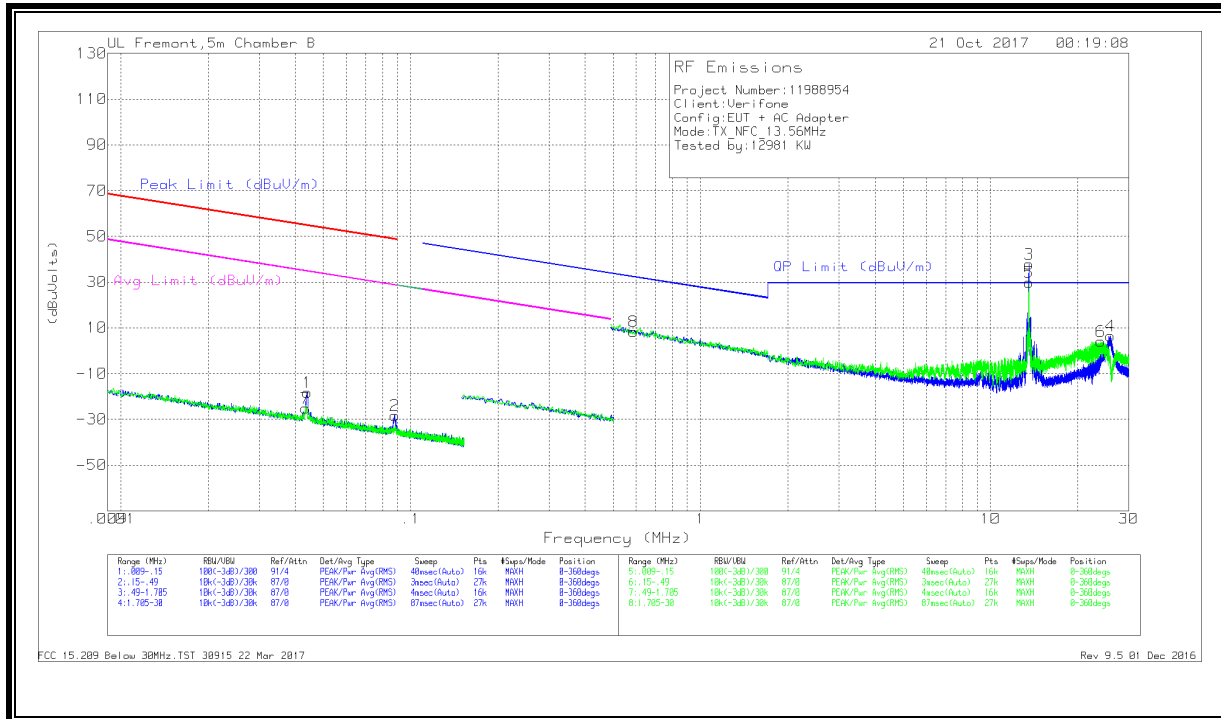

Trace Markers

Marker	Frequency (MHz)	Meter Reading (dBuV)	Det	Loop Antenna (dB/m)	Cbl (dB)	Dist Corr 300m	Corrected Reading (dBuVolts)	Peak Limit (dBuV/m)	Margin (dB)	Avg Limit (dBuV/m)	Margin (dB)	Peak Limit (dBuV/m)	Margin (dB)	Avg Limit (dBuV/m)	Margin (dB)	Azimuth (Degs)
7	.04335	40.88	Pk	12.6	1.4	-80	-25.12	54.84	-79.96	34.84	-59.96	-	-	-	-	0-360
1	.04391	47.8	Pk	12.6	1.4	-80	-18.2	54.73	-72.93	34.73	-52.93	-	-	-	-	0-360
2	.08827	38.64	Pk	11.7	1.4	-80	-28.26	48.67	-76.93	28.67	-56.93	-	-	-	-	0-360

Pk - Peak detector

Marker	Frequency (MHz)	Meter Reading (dBuV)	Det	Loop Antenna (dB/m)	Cbl (dB)	Dist Corr (dB) 40Log	Corrected Reading (dBuVolts)	QP Limit (dBuV/m)	Margin (dB)	Peak Limit (dBuV/m)	Margin (dB)	Avg Limit (dBuV/m)	Margin (dB)	Azimuth (Degs)
8	.58777	35.22	Pk	11.6	1.5	-40	8.32	32.22	-23.9	-	-	-	-	0-360
3	*13.55945	65.88	Pk	10.4	1.6	-40	37.88	-	-	-	-	-	-	0-360
5	*13.55945	57.77	Pk	10.4	1.6	-40	29.77	-	-	-	-	-	-	0-360
6	24.01902	33.22	Pk	9.1	1.7	-40	4.02	29.5	-25.48	-	-	-	-	0-360
4	25.90961	35.98	Pk	8.9	1.7	-40	6.58	29.5	-22.92	-	-	-	-	0-360

* - indicates fundamental frequency

Pk - Peak detector

7.4. TX SPURIOUS EMISSIONS (30 – 1000MHz)

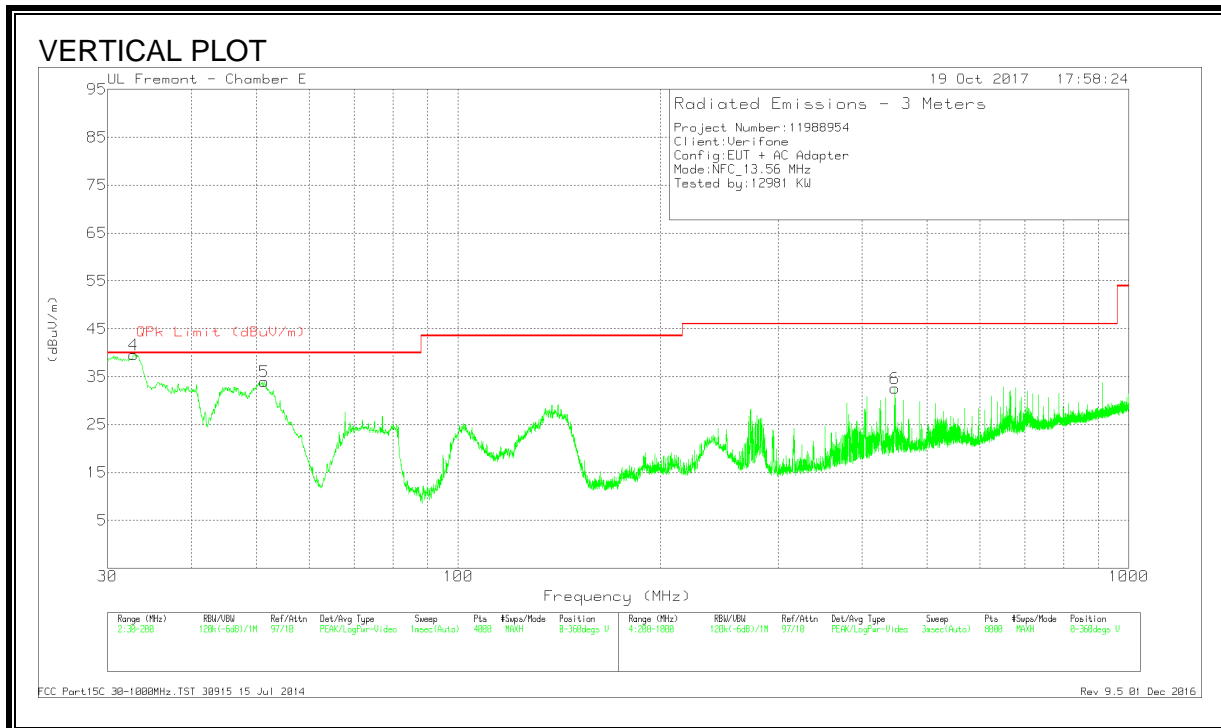
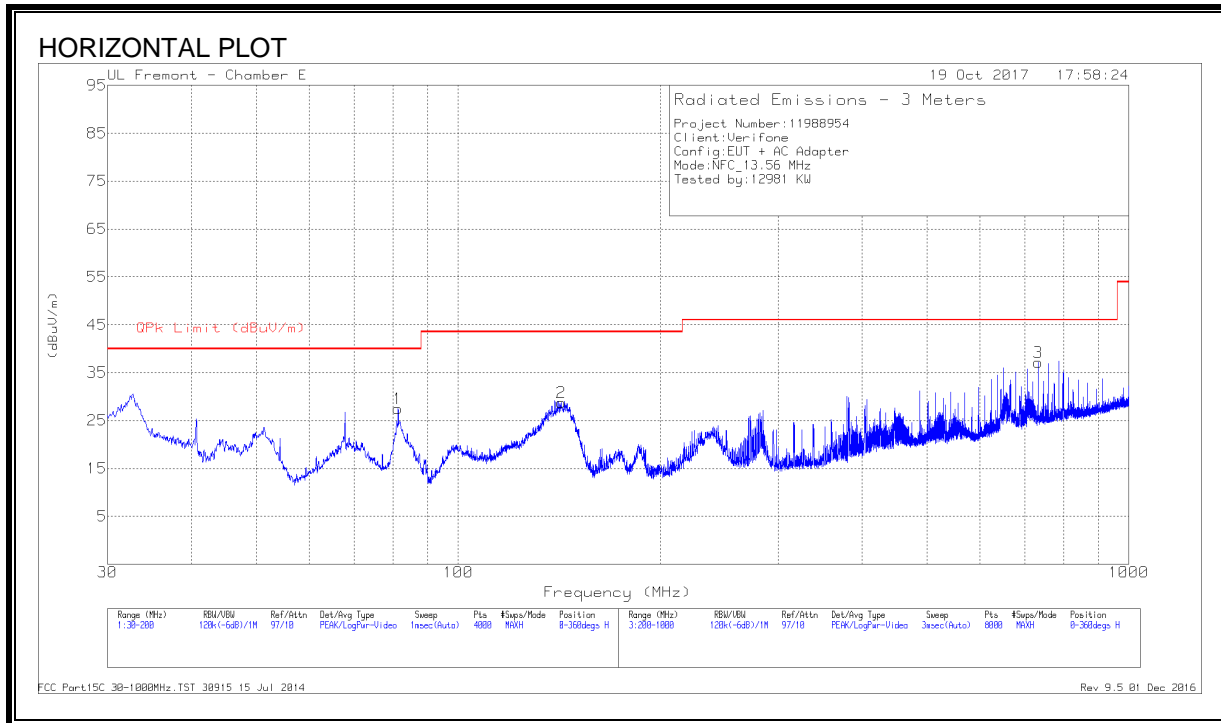

Trace Markers

Marker	Frequency (MHz)	Meter Reading (dBuV)	Det	AF T900 (dB/m)	Amp/Cbl (dB)	Corrected Reading (dBuV/m)	QPk Limit (dBuV/m)	Margin (dB)	Azimuth (Degs)	Height(cm)	Polarity
4	33.0275	45.71	Qp	22.7	-31.6	36.81	40	-3.19	2	109	V
5	51.3864	51.38	Qp	10.4	-31.3	30.48	40	-9.52	289	103	V
1	81.3533	47.73	Pk	10.8	-31	27.53	40	-12.47	0-360	200	H
2	142.3991	42.23	Pk	16.9	-30.4	28.73	43.52	-14.79	0-360	200	H
6	447.4322	40.82	Pk	20.3	-28.5	32.62	46.02	-13.4	0-360	101	V
3	732.2692	40.08	Pk	24.3	-27.2	37.18	46.02	-8.84	0-360	100	H

Pk - Peak detector

Qp - Quasi-Peak detector