

UX700

Installation Guide



UX700 Installation Guide
© 2022 Verifone, Inc.

All rights reserved. No part of the contents of this document may be reproduced or transmitted in any form without the written permission of Verifone, Inc.

The information contained in this document is subject to change without notice. Although Verifone has attempted to ensure the accuracy of the contents of this document, this document may include errors or omissions. The examples and sample programs are for illustration only and may not be suited for your purpose. You should verify the applicability of any example or sample program before placing the software into productive use. This document, including without limitation the examples and software programs, is supplied "As-Is."

Verifone and the Verifone logo are registered trademarks of Verifone. Other brand names or trademarks associated with Verifone's products and services are trademarks of Verifone, Inc.

All other brand names and trademarks appearing in this manual are the property of their respective holders.

Comments? Please e-mail all comments on this document to your local Verifone Support Team.

Verifone, Inc.

1-800-Verifone

www.verifone.com



CONTENTS

PREFACE	5
Audience	5
Organization	5
Related Documentation	6
Conventions and Acronyms	6
Document Conventions	6
Acronym Definitions	7
 CHAPTER 1	
Device Overview	
Features and Benefits	9
Exceptional Ease of Use	10
Performance and Durability	10
Security	10
Contactless Capability	10
Communication Technology	10
Connectivity	10
 CHAPTER 2	
Setup	
Environmental Factors	11
Contactless Considerations	11
Personal Security Considerations	11
Selecting Unit Location	12
Choosing Mounting Location	12
Inside the Shipping Carton	12
Installing or Replacing SAM Cards	13
Examining Connection Port	14
To Connect the Terminal to a PC	16
To Enable Service Switch	17
Disconnecting Cables	17
Mounting the Device	18
Using the Smart Card Reader	18
Using the Device	20
Using the Multi-Card Reader	20
CTLS Transaction	21
 CHAPTER 3	
Specifications	
Unit Power Requirements	23
Temperature	23
Memory	23
Magnetic Card Reader	23
Smart Card Reader	23
Contactless Card Reader	24
SAM Card Reader	24
Display	24
External Dimensions	24
Processor	24

	Keypad	24
	Payment	24
	Multimedia	24
	Communication.	24
	Physical Interface	24
	Camera/Barcode Scanner	25
	Security.	25
CHAPTER 4		
Maintenance and Cleaning	General Care	27
	Additional Safety Information	27
	Surface Cleaning	28
	Smart Card Reader Cleaning	28
	Magnetic Stripe Cleaning	29
CHAPTER 5		
Verifone Service and Support	Returning a Device for Service.	31
	Accessories and Documentation	32
	Connection Cables	33
	Power Cables	33
	Cleaning Kit.	33
	Documentation	33
CHAPTER 6		
Troubleshooting Guidelines	Device Does Not Start	35
	Device Display Does Not Show Correct/Readable Info	35
	Blank Display	36
	Transactions Fail to Process	36
CHAPTER 7		
Port Pinouts	UX700 Port Pinouts	37
	RS-232 Port (COM1)	37
	RS-232 Port (COM2)	37
	Ethernet Port (LAN).	38
	USB Pinout (Host Port).	38
	USB Pinout (Client Port).	38
	Power Port (DC-in or Printer)	38



This guide is the primary source of information for setting up and installing the UX700 unit.

Audience

This guide describes the card reader’s features and provides the basic information for its installation and configuration.

Organization

This guide is organized as follows:

[Chapter 1, Device Overview](#). Provides an overview of the device.

[Chapter 2, Setup](#). Explains setup and installation of the device, selecting a location, and establishing connections with other devices.

[Chapter 3, Specifications](#). Discusses the power requirements and dimensions of the device.

[Chapter 4, Maintenance and Cleaning](#). Explains maintenance of the device.

[Chapter 5, Verifone Service and Support](#). Provides information on contacting your Verifone service provider and information on how to order accessories or documentation from Verifone.

[Chapter 6, Troubleshooting Guidelines](#). Provides troubleshooting guidelines should you encounter a problem with unit installation and configuration.

[Chapter 7, Port Pinouts](#). Provides different pinout settings for ports on the UX700 persistent board as well as model-dependent boards.

[Appendix A, UX700 Caution and Warning Messages](#). Shows the UL/cUL certification-compliant translations of all Warning and Caution messages in this installation guide.

Related Documentation

To learn more about the card reader and controller device, refer to the following set of documents and their associated Verifone Part Numbers (VPNs).

UX700 Certifications and Regulations Sheet

VPN DOC184-002-EN

UX700 Quick Installation Guide

VPN DOC184-003-EN

Conventions and Acronyms



This section describes the conventions and acronyms used in this guide.

Document Conventions

Various conventions are used to help you quickly identify special formatting.

Table 1 describes these conventions and provides examples of their use.

Table 1 Document Conventions

Convention	Meaning	Example
Blue	Text in blue indicates terms that are cross referenced.	See Conventions and Acronyms .
	The pencil icon is used to highlight important information.	If exchanging cables, use a Verifone-approved cable.
	The caution symbol indicates possible hardware or software failure, or loss of data.	Using an incorrectly rated power supply can damage the unit or cause it to malfunction.
	The lightning symbol is used as a warning when bodily injury might occur.	For safety, do not string cables or cords across a walkway.

Acronym Definitions Various acronyms used in place of full definition. [Table 2](#) presents acronyms and their definitions.

Table 2 Acronym Definitions

Acronym	Definitions
COM	Communications port
CTLS	Contactless
CTS	Clear to Send
DDRAM	Double Data Rate Random Access Memory
ETH	Ethernet
HW	Hardware
LCD	Liquid Crystal Display
MDB	Multi-Drop Bus
MSR	Magnetic Stripe Card Reader
NAND-flash	Non-volatile storage technology
NFC	Near Field Communications
PCI	Payment Card Industry
PIN	Personal Identification Number
PTS	PIN Transaction Security
RF	Radio Frequency
RS-232	Recommended Standard 232
RTS	Request to Send
SAM	Secure Access Module
SRED	Secure Reading and Exchange of Data
USB	Universal Serial Bus
VM	Vending Machine
WAN	Wide Area Networks



Device Overview

The Verifone UX700 is a powerful device used in various unattended scenarios including vending, ticketing, parking and petrol bunk or pump. It can operate both as an independent primary control device or as a companion device to process payment transactions.

The Verifone UX700 device supports all payment methods - magnetic stripe, EMV, and NFC/Contactless Reader, including Apple Pay, Google Pay, and Samsung Pay mobile wallets. The easy to read color touch screen supports all payment related user interactions and keypad for secure PIN entry.

It has the ability to run Android applications, like loyalty and inventory. It also enables clients to remotely monitor and update their devices using Verifone’s estate management solution. The UX700 device supports Bluetooth and Wi-Fi and meets PCI-PTS 6.X SRED requirements for maximum security. This chapter provides a brief description of the UX700 device.



Figure 1 UX700 Device

Features and Benefits

Following are the features and benefits of UX700 Device.

Exceptional Ease of Use

- Large 5” LCD for unlimited application possibilities and easy readability under various lighting conditions.
- Touchscreen for icon-based applications or electronic signature capture support.
- Magnetic stripe card reader for optimal card reading.

Performance and Durability

- Fast transactions due to powerful ARM Cortex A53 64-bit processor.
- 2GB RAM/16GB ROM, SD card slot size that supports up to 32GB SD memory.

Security

- Incorporates tamper-sensing circuitry to detect unauthorized intrusion and supports a broad spectrum of software-based security features.
- PCI-PTS 6.X approved for debit and other PIN-based transactions.
- EMV Level 1 Type approval.
- Supports reliable security features including TLS, VeriShield file, authentication and VeriShield Protect to help prevent fraud and other intrusions.

Contactless Capability

- Advanced contactless architecture that future-proofs investment with a single contactless interface (SingleCI), SoftSAMs, and side-by-side application architecture.
- Dedicated tap zone for optimized user experience.
- Accepts EMV, NFC, QR Code and mag-stripe contactless payments as well as PIN-based transactions.

Communication Technology

- Bluetooth: Simple, plug-and-play installation for locations that need the short-range wireless capability. Eddystone and iBeacon profiles are also supported.
- Dual-band Wi-Fi.

Connectivity

- Ethernet, USB-Client, USB-Host, serial RS-232, MDB

Setup

This chapter describes the setup procedure for the card reader and controller in the following sections:

- Environmental Factors
- Selecting Unit Location
- Inside the Shipping Carton
- Installing or Replacing SAM Cards
- Examining Connection Port
- Using the Smart Card Reader
- Using the Device
- CTLS Transaction

Environmental Factors

- Do not use the device where there is excess heat, dust, humidity, moisture, caustic chemicals or oils.
- Keep the device away from direct sunlight and anything that radiates heat.

Contactless Considerations

The contactless antenna is located around the display. Avoid having metallic objects in the proximity of a contactless antenna.

CAUTION

Using an enclosed metal frame may negatively affect contactless performance.

Personal Security Considerations

Always exercise extreme caution when conducting transactions especially during PIN entry. Be close to the UX700 device to avoid others from seeing the information entered.

Selecting Unit Location

Use the following guidelines when selecting a location for your device.

- Select a location convenient for the customer.
- Avoid dusty, hot or damp locations.
- To minimize data reading or writing errors, pick a location free from magnetic interference. Choose a spot a safe distance away from objects or units that generate magnetism.

Choosing Mounting Location

Choose a mounting location that ensures the card slot is in full view of the cardholder during card insertion.

NOTE



The front panel of the device meets the IP65 standards for installation in outdoor environments.

Inside the Shipping Carton

Open the shipping carton and carefully inspect its contents for possible tampering or shipping damage. The device is a secure product. Tampering causes it to cease to function or to operate in an unsecured manner.

Unpacking the Shipping Carton

To unpack the shipping carton:

- 1 Carefully inspect the shipping carton and its contents for possible tampering or damage.
- 2 Validate the authenticity of the sender by verifying the shipping tracking number and other information located on the product order paperwork.
- 3 Remove and inspect the contents of the shipping carton. The carton may include all or any of the following:
 - Device
 - Additional accessories (optional)

NOTE



Power supply and connectivity cables are shipped separately or depending upon the customer requirements.

- 4 Remove all plastic wrapping from the device and components.
- 5 Remove the clear protective film from the display.
- 6 Inspect the terminal for possible tampering; see how to identify signs of tampering in section **Periodic Inspection**.

- 7 Save the shipping carton and packing material for future repacking or moving of the device.

WARNING

Ne pas utiliser un appareil qui a été altéré ou endommagé. Cet appareil est équipé d'étiquette d'inviolabilité. Si une étiquette ou d'un composant semble être endommagé, en aviser immédiatement la compagnie maritime et votre représentant Verifone ou prestataire de services.

Do not use a tampered or damaged unit. The device comes equipped with tamper-evident labels. If a label or component appears damaged, please notify the shipping company and your Verifone service provider immediately.

Periodic Inspection Periodically inspect the terminal for possible tampering. Signs of tampering include:

- Overlays in the PIN pad area
- Wires protruding out of the device
- Foreign objects inserted into the smart card slot or magnetic stripe slot
- Any bumps in the casing below the mag stripe slot and any noticeable additional mag stripe head from the side
- Signs of damage to the tamper-evident labels
- A Tamper Warning message on the device display

If any device is found to have been tampered with, please remove it from service immediately, keep it available for a potential forensics investigation, and notify your company security officer and your local Verifone representative or service provider. To contact Verifone, please see [Verifone Service and Support](#).

Installing or Replacing SAM Cards

You may need to install a Security Access Module (SAM) card or replace the old card. You can find three SAM slots and one Micro SD card slot on the UX700 (see Figure 2).

CAUTION

Respecter les précautions standard dans la manipulation d'appareils sensibles aux décharges électrostatiques. Les décharges électrostatiques peuvent endommager le matériel. Verifone recommande d'utiliser un bracelet anti-statique à la terre.

Observe standard precautions in handling electrostatically sensitive devices. Electrostatic discharges can damage the equipment. Verifone recommends using a grounded anti-static wrist strap.

To install or replace SAM cards

- 1 Disconnect the device from all power sources.
- 2 Disconnect the device from any external devices.

- Carefully slide the SAM card into the slot, by aligning the card and carefully sliding into the slot until fully inserted.

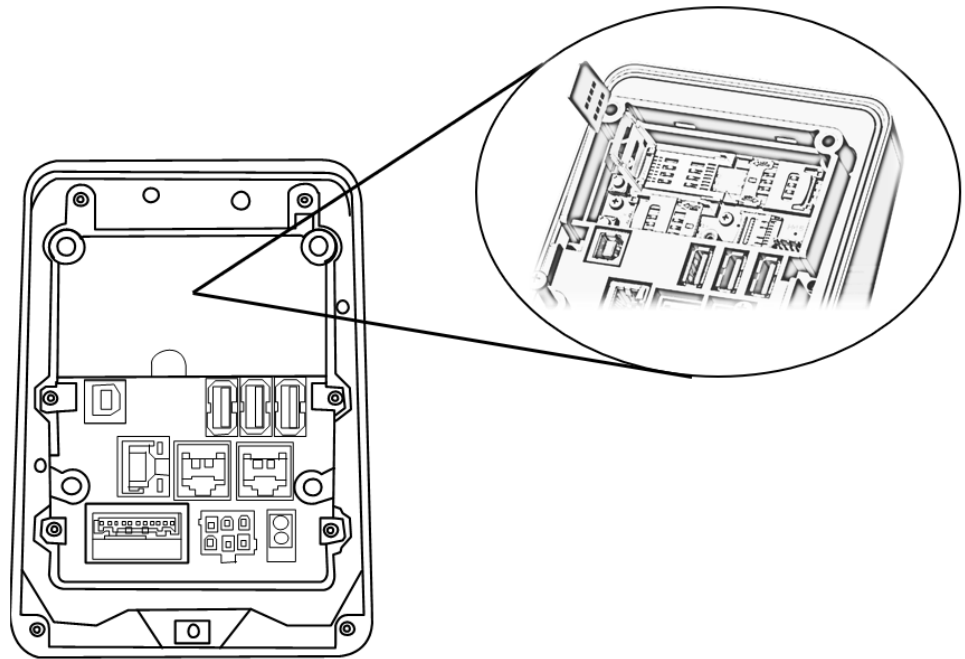

Figure 2 Installing SAM Card



- The SAM card holders ensure that cards fit into the slots in only one way.
- The rectangular symbols show the SAM card's notched corners are always visible. These indicate which way the card notch should face before you insert the card into the SAM slot.
- The circular symbols indicate the SAM card slot numbers.

- Install additional SAM cards in the available slots as necessary.

Examining Connection Port

The device has dedicated input/output connectors: Ethernet, RS-232, USB-A, USB-B and DC power.

To Connect the Terminal Power Supply Insert the power supply cable to the UX700 device and plug the other end into the power supply.

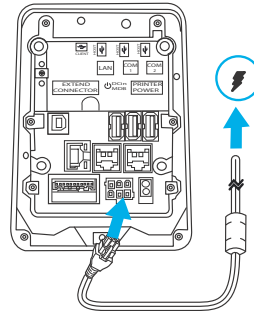

Figure 3 UX700 Power Supply Connection



To protect against possible damage caused by lightning strikes and electrical surges, consider installing a power surge protector.

To Connect the Terminal to a PC Insert the RS-232 cable to the UX700 device and the PC.

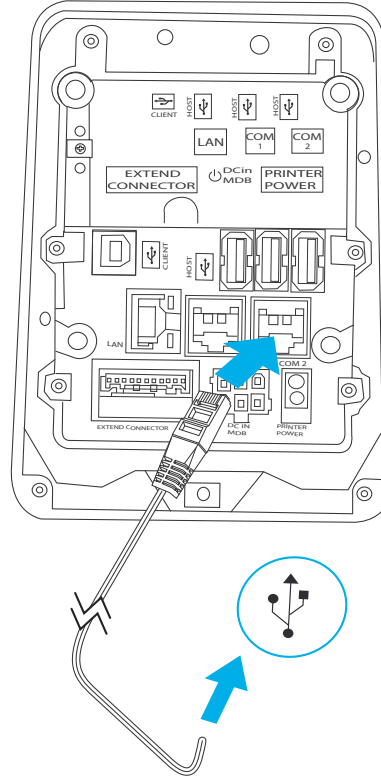

Figure 4 Connecting to a PC

To Connect the Device to the LAN Insert the Ethernet cable to the UX700 device and the socket.

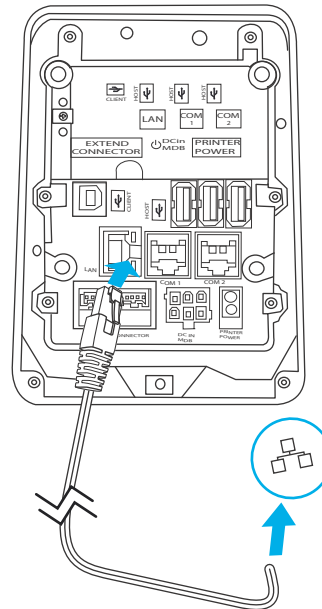

Figure 5 Connecting to Ethernet Port

To Enable Service Switch

This service switch is used to select safe boot for the Android processor.

Disconnecting Cables

To disconnect cables, use the same steps described above in reverse. If exchanging cables, use Verifone-approved cables. See [Accessories and Documentation](#) for cable part numbers and ordering information.

Mounting the Device

Use the following procedure to mount the UX700 to a suitable mounting surface.

CAUTION



Make sure that your mounting frame has a thickness of 2 mm.

NOTE



Your mounting surface may have different installation instructions. Refer to the user guide of your mounting device for further information.

To mount the unit 1 Align the UX700 stud holes with the holes on the mounting surface.

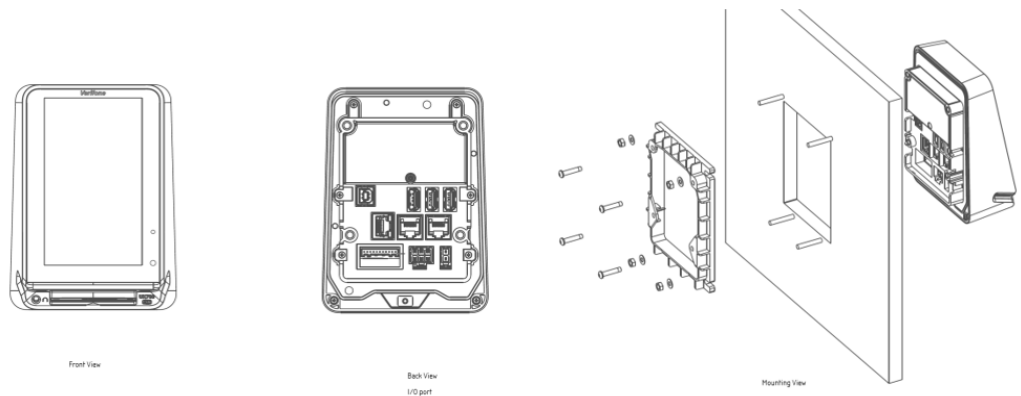

Figure 6 Mounting the UX700

- 2 Place the reader flush onto the mounting slot.
- 3 Secure the unit with M5 nuts with a minimum length of 12 mm. Tighten the nuts using the recommended torque of 7.0 kg-cm (6.1 lbf.in).

NOTE



You can also mount the UX700 using welded screw bolts on the inner side of the mounting plate. This prevents any vandalism of the screw heads on the outer surface.

- 4 Connect flexible tubing with 9mm inner diameter to the drain nozzle at the bottom of the UX700 and place the other end of the tubing at an appropriate drainage area.

NOTE



The nozzle drains water out of the bezel area through the flexible tube. Ensure that the tubing is properly dressed and mounted as vertical as possible (without any loops) to ensure smooth water drainage.

Using the Smart Card Reader

Insert the smart card to proceed with the EMV transaction. EMV supports credit card and debit card transactions.

To Conduct a Smart Card Transaction

- 1 Position the smart card with the contacts facing upward (see illustration below).
- 2 Insert the card into the reader slot in a smooth, continuous motion until it seats firmly.
- 3 Wait for the application to indicate a completed transaction before removing the card. Premature card removal invalidates the transaction.

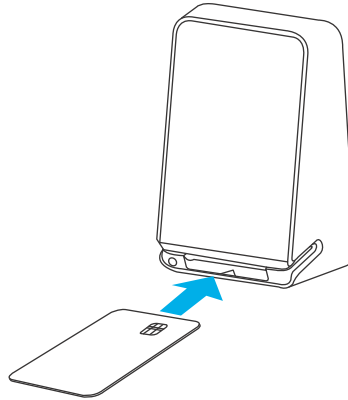
**Figure 7** Inserting a Smart Card**WARNING**

Vous allez perdre des fichiers de données de la transaction n'est pas encore en mémoire si il ya une perturbation dans l'alimentation lors d'une transaction.

You will lose transaction data files not yet stored in memory if there is a disruption in power supply during a transaction.

Using the Device

Card transaction procedures vary depending on the application. Verify the proper procedure with your application provider before performing a card transaction.

Using the Multi-Card Reader

The UX700 supports magnetic stripe cards as well as smart cards. Use the following steps in conducting UX700 card transactions.

To conduct a Card Transaction

- 1 Position the card with the magnetic stripe facing backward.
- 2 To ensure a proper read of the magnetic the swipe card, insert the magnetic card from the side of the device, as shown in the illustration below.

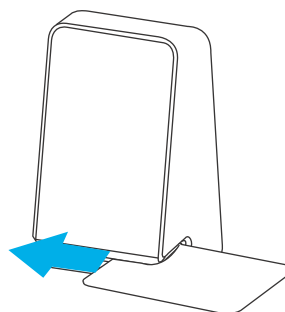

Figure 8 Using the Multi-Card Reader

- 3 Swipe the card through the magnetic card reader.

WARNING



You will lose transaction data files not yet stored in memory if there is a disruption in power supply during a transaction.

NOTE



With magnetic stripe cards, swipe completes the transaction.

- 4 If using a smart card, insert the card and follow the on-screen instructions before removing the card.

CAUTION



Lorsque vous utilisez une carte à puce, laissez la carte dans le lecteur jusqu'à ce que la transaction est terminée.

Retrait prématuré peut annuler la transaction.

When using a smart card, leave the card in the reader until the transaction is complete.

Premature card removal can void the transaction.

CTLS Transaction

The UX700 device supports contactless credit or debit card transactions. To perform a contactless transaction, gently tap the card or hold the card on the surface of the display on the contactless logo.

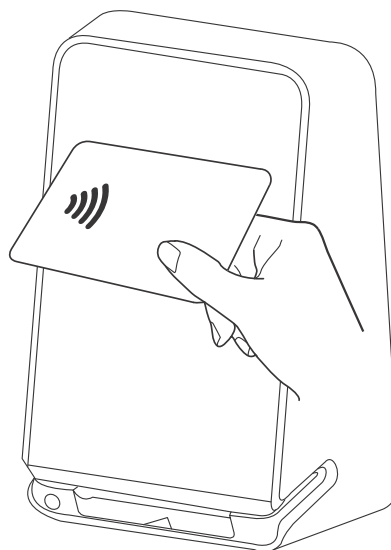

Figure 9 Using the CTLS Reader

Specifications

This chapter discusses the power requirements and dimensions of the UX700 device.

Unit Power Requirements

- Operating Voltage: 9V DC - 43V DC
- Idle Power:
 - 3 W (50% backlight) = 12V/0.25A, real measurement
- Typical Power:
 - 1.5W (CTLS read) = 5V/0.3A
 - 12W (RS232-V out) = 12V/1A
 - 2.5W (USB-Master) = 5V/0.5A per USB port
- Sleep Mode: Currently UX700 doesn't support sleep mode (TBD)

Temperature

- Operating Environment:
 - Temperature: -30°C to 70°C (-22°F to 158°F)
 - Relative humidity: 5% to 90% RH non-condensing
 - Storage temperature: -30°C to 80°C (-22 °F to 176 °F)



NOTE If this device is to be used in the Nordic countries, or in any environment where the temperature range exceeds the product's operating temperature, it is the responsibility of the integrators to ensure that the ambient environment is controlled in such a way to ensure that the product operates within the specified temperature range.

Memory

- 2 GB SDRAM
- 16 GB Flash
- Micro SD expansion -- compliant with SD3.0 standard

Magnetic Card Reader

- Triple track MSR

Smart Card Reader

- Partial insertion
- Non-sliding
- Card Conserving plated landing contacts
- ISO 7810, 7813 smart card reader

Contactless Card Reader

- EMV CTLS Level 1 and Level 2 Type Approval
- Supports contactless cards as well as NFC phones, supporting the following protocols:
 - ISO 14443 A&B
 - MiFare (MiFare + / DESfire)
 - ISO 18092 Active Communications (NFC - peer-to-peer mode)
 - FeliCa
 - PayPass
 - payWave

SAM Card Reader

- Three Security Access Modules (SAMs) card slots
- One Micro SD

Display

- 5" screen size
- 720 x 1280 HD resolution
- IPS LCD touchscreen

External Dimensions

- Length: 70 mm (2.75")
- Width: 110 mm (4.33)
- Height: 146 mm (5.75")
- Weight: 586 g

Processor

- Quad Core Cortex A53, 1.3GHz

Keypad

- On-screen

Payment

- MSR
- SCR
- CTLS
- QR Code

Multimedia

- Speaker, audio jack with microphone connection
- Integrated microphone; HD video decode

Communication

- Bluetooth® 4.2 BLE
- Dual band WiFi 11a/b/g/n

Physical Interface

- Serial port (RS232) x 2
- Ethernet port

- USB-A Host port x 3
- USB-B Client port x 1
- MDB x 1
- GPIO x 1
- Switched Power output x 1

Camera/Barcode Scanner

- 2 MP (Front camera)
- QR code scanning

Security

- PCI PTS 6.X-approved
- SRED
- Supports AES DUKPT



Maintenance and Cleaning

The UX700 device has no user-maintainable parts. It can, however, be cleaned.

General Care

Your device is a product of superior design and should be treated with care. The following suggestions will help you protect your warranty coverage.

- Before installation, keep the device dry. Precipitation, humidity, and all types of liquids or moisture can contain minerals that will corrode electronic circuits. If your device gets wet, switch off the power, and allow the device to dry completely before replacing it.
- Do not store the device in dusty and dirty areas. Its moving parts and electronic components can be damaged.
- Do not store the device in hot areas. High temperatures can shorten the life of electronic devices, damage batteries, and warp or melt certain plastics.
- Do not store the device in cold areas. It can form moisture inside the device and damage electronic circuit boards when the device returns to its normal temperature.
- Do not drop, knock, or shake the device. Rough handling can break internal circuit boards and fine mechanics.
- Do not paint the device. Paint can clog the moving parts and prevent proper operation.
- Keep the device free from any small and loose items (such as paper clips, staples, or coins) that could accidentally get inside it through an opening, such as the SAM slots or the primary smart card reader slot.
- Do not attempt to open the device other than as instructed in this guide. This device has security features that protect it from tampering. For example, the file content will be deleted if the device's outer casing is opened.

These suggestions apply equally to your device, or any of its attachments, or accessories. If your device is not working properly, then take it to the nearest authorized service facility for servicing or replacement. For your safety, have this device serviced only by a Verifone-authorized service provider.

Additional Safety Information

The following are additional safety information in using this device.

Surface Cleaning To clean the device, use a clean cloth slightly dampened with water and a drop or two of mild soap. For stubborn stains, use alcohol or an alcohol-based cleaner.



CAUTION *N'utilisez jamais de diluant, le trichloréthylène ou des solvants cétoniques - ils peuvent détériorer les pièces en plastique ou en caoutchouc.*

Never use thinner, trichloroethylene, or ketone-based solvents – they can deteriorate plastic or rubber parts.

Do not spray cleaners or other solutions directly onto the device.

Smart Card Reader Cleaning The Smart Card Reader (SCR) must be cleaned regularly, as dirt accumulation can lead to SCR reading problems. SCR can be cleaned using commercially available card reader cleaning cards or using recommended Verifone cleaning card (PN 02746-02).

Cleaning the SCR To clean the SCR:

- 1 Inspect the device's SCR for the presence of foreign objects before cleaning the Customer Smart Card.
 - a If the unit shows no presence of foreign objects, test the SCR function and record results. Proceed to [Step 2](#).



CAUTION Send your device to a Verifone authorized repair center if foreign objects are found in the SCR at any time during SCR inspection, test diagnostics, or cleaning process. Removal of foreign objects from the SCR by customers may void the device warranty.

- 2 Clean the SCR with an approved or recommended Verifone cleaning card. It is always advised to use new cleaning cards every time.



NOTE If using a commercially available cleaning card use ONLY an approved SCR cleaning card made specifically for POS SCR devices or Petroleum SCR.

- 3 Test the SCR after cleaning.
 - a If SCR tests out okay as “passing”, then the unit is ready for Customer Smart Card use.
 - b If SCR tests out as “failing”, then send the unit for repair. Provide details to repair center when SCR fails to test, either before cleaning OR after cleaning OR both before and after cleaning.

Magnetic Stripe Cleaning The Magnetic Stripe Reader (MSR) must be cleaned regularly daily to once a week, depending on usage), as dirt accumulation can lead to MSR reading problems. MSR can be cleaned using commercially available card reader cleaning cards or using recommended Verifone cleaning card ([PN 02746-02](#)).

NOTE



If using a commercially available cleaning card use **ONLY** an approved MSR cleaning card made specifically for POS MSR Card reader devices or Petroleum MSR card readers.

Verifone Service and Support

Contact your local Verifone representative or service provider for any problems with your device.

For product service and repair information:

- USA – Verifone Service and Support Group, 1-800-837-4366, Monday - Friday, 8 A.M. - 8 P.M., Eastern time
- International – Contact your Verifone representative

Returning a Device for Service

Before returning the UX700 device, you must obtain an MRA number. The following procedure describes how to return one or more devices for repair or replacement (U.S. customers only).

NOTE

Customers outside the United States are advised to contact their local Verifone representative for assistance regarding service, return, or replacement of devices and accessories.

- 1 Get the following information from the printed labels at the back of each UX700 device to be returned:
 - Product ID, including the model and part number. For example, “UX700” and “M184-XXX-XXX-XXX.”
 - Serial number (S/N nnn-xxx-xxx)
- 2 Obtain the MRA number(s) by completing one of the following:
 - Call Verifone toll-free within the United States at 1-800-Verifone and follow the automated menu options.
 - Select the MRA option from the automated message. The MRA department is open Monday to Friday, 8 A.M.–8 P.M., Eastern Time.
 - Give the MRA representative the information you gathered in Step 1.
 - Complete the Inquiry Contact Form at <https://www.verifone.com/en/us/contact-us>.
 - Address the Subject box to “Verifone MRA Dept.”

- Reference the model and part number in the Note box.



One MRA number must be issued for each UX700 device you return to Verifone, even if you are returning several of the same models.

- 3 Describe the problem(s).
- 4 Provide the shipping address where the repaired or replacement unit must be returned.
- 5 Keep a record of the following items:
 - Assigned MRA number(s).
 - Verifone serial number assigned to the UX700 device you are returning for service or repair (device serial numbers are located at the back of the unit.)
 - Shipping documentation, such as air bill numbers used to trace the shipment.
 - Model(s) returned (model numbers are located on the Verifone label at the back of the UX700 device)

Accessories and Documentation

Verifone produces accessories and documentation for the card reader. When ordering, please refer to the part number in the left column.

Verifone Online Store at <https://www.verifone.com/en/us/contact-us>

- USA – Verifone Service and Support Group, 1-800-837-4366, Monday - Friday, 8 A.M. - 8 P.M., Eastern time
- International – Contact your Verifone representative

Connection Cables

CBL159-312-01-A	LAN cable for Ethernet connections.
26264-01-R	Cash register cable, RJ45-SUBD9f, 1.0m
26264-02-R	Cash register cable, RJ45-SUBD9f, 2.0m
CBL184-700-01-A	CABLE, DEBUG UX700 8-PIN WTB(2.0MM) TO ONE MICRO USB TWO UART FUNCTION (FOR INTERNAL USE ONLY)
CBL184-700-02-A	CABLE, DEBUG UX700 AUDIO & GPIO EXTEND CABLE (FOR INTERNAL USE ONLY)
10000284-002	CABLE, USB 2.0, TYPE A MALE TO TYPE B MALE, 3FT, BLACK

Power Cables

CBL000-039-02-A	Australia power cord for PWR159-001-01-A PSU
CBL184-700-03-A	CABLE, UX700 RADIO PWR, Y-STYLE 0.2M/0.6M
CBL258-001-01-A	EU power cord for PWR159-001-01-A PSU
CBL258-006-01-A	US power cord for PWR159-001-01-A PSU
CBL258-004-01-A	UK power cord for PWR159-001-01-A PSU
CBL258-014-01-A	South Africa power cord for PWR159-001-01-A PSU
PWR159-001-01-B	12 V, 3.3 A L5 EEF power supply unit (PSU) for UX700
PWR159-002-01-B	12 V, 3.3 A L6 EEF power supply unit (PSU) for UX700

Cleaning Kit

02746	Verifone Cleaning Kit.
-------	------------------------

Documentation

VPN DOC184-002-EN	<i>UX700 Certifications and Regulations Sheet</i>
VPN DOC184-003-EN	<i>UX700 Quick Installation Guide</i>



Troubleshooting Guidelines

The troubleshooting guidelines provided in the following section are included to help you install and configure your UX700 successfully. Typical examples of malfunction you may encounter while operating your UX700 device and steps you can take to resolve them are listed in this chapter.

If the problem persists even after performing the outlined guidelines or if the problem is not described below, contact your local Verifone representative for assistance.

NOTE

The UX700 comes equipped with tamper-evident labels. The UX700 unit contains no user serviceable parts. Do not, under any circumstance, attempt to disassemble the device. Perform only those adjustments or repairs specified in this guide. For all other services, contact your local Verifone service provider. Service conducted by parties other than authorized Verifone representatives may void any warranty.

CAUTION

Before troubleshooting, ensure that the power supply being used to power the device matches the requirements specified at the bottom of the device. (See [Specifications](#), for detailed power supply specifications.) Obtain the appropriately rated power supply before continuing with troubleshooting.

Device Does Not Start

If the device does not start:

- Ensure that the device is plugged into a dedicated power source.
- Check if the power cable connector is plugged in properly.

Device Display Does Not Show Correct/Readable Info

If the device display does not show correct/readable info:

- Check all the cable connections. If the problem persists, then contact your local Verifone representative for assistance.

Blank Display

When the device display is blank:

- If the device display is dark, tap the screen with your finger. If the unit was in screen-saver mode, the screen will turn on when touched.
- If the display does not show correct or readable information, then check all the cable connections. If the problem persists, then contact your local Verifone representative for assistance.

Transactions Fail to Process

There are several possible reasons why the unit may not be processing transactions. Use the following steps to troubleshoot failures.

Checking Magnetic Card Reader

To check magnetic card reader:

- 1 Perform a test transaction using one or more different magnetic stripe cards to ensure that the problem is not a defective card.
- 2 Ensure that you are swiping cards properly (see [Using the Magnetic Card Reader](#)).
- 3 Process a transaction manually using the keypad instead of the card reader. If the manual transaction works, then the problem may be a defective card reader.
- 4 Contact your local Verifone representative if the problem persists.

Checking Smart Card Reader

To check smart card reader:

- 1 Perform a test transaction using several different smart cards to ensure the problem is not a defective card.
- 2 Ensure that the card is inserted correctly (see [Using the Smart Card Reader](#)).
- 3 Ensure that the SAM cards are properly inserted in the slots and are properly secured.
- 4 Contact your local Verifone representative if the problem persists.



Port Pinouts

This section contains port pinout tables for the UX700.

UX700 Port Pinouts

Refer to the following UX700 port pinout diagrams.

RS-232 Port (COM1)

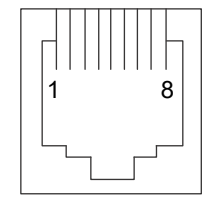
Connector	PIN	Function	Description
	1	Portpwr (9 to 43 V DC)	PowerOut, max 1 A
	2	NC	No connection
	3	NC	No connection
	4	GND	Power ground
	5	RXD	Receive data
	6	TXD	Transmit data
	7	CTS	Clear to send
	8	RTS	Request to send



NOTE The 10-pin download cable (VPN 26264) connects to the 8-Pin RS-232 port of the device, wherein Pin 2 from the cable corresponds to Pin 1 on the RS-232 port.

RS-232 Port (COM2)

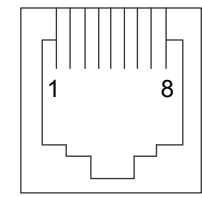
Connector	PIN	Function	Description
	1	Portpwr (9 to 43 V DC)	PowerOut, max 1 A
	2	NC	No connection
	3	NC	No connection
	4	GND	Power ground
	5	RXD	Receive data
	6	TXD	Transmit data
	7	CTS	Clear to send
	8	RTS	Request to send

Ethernet Port (LAN)

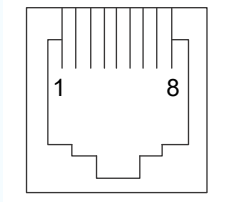
Connector	PIN	Function	Description
	1	TXD+	Transmit data +
	2	TXD-	Transmit data -
	3	RXD+	Receive data +
	4	NC	No connection
	5	NC	No connection
	6	RXD-	Receive data -
	7	NC	No connection
	8	NC	No connection

USB Pinout (Host Port)

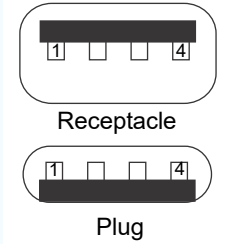
Connector	PIN	Function	Description
	1	+5 V	5 V USB Power (500 mA)
	2	DATA-	USB Host Signal -
	3	DATA+	USB Host Signal +
	4	GND	USB ID pin/Ground

USB Pinout (Client Port)

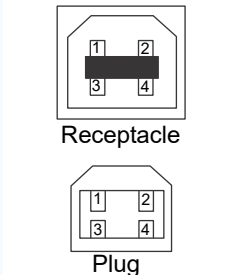
Connector	PIN	Function	Description
	1	+5 V	5 V USB Power
	2	DATA-	USB Device Signal -
	3	DATA+	USB Device Signal +
	4	GND	USB Ground

Power Port (DC-in or Printer)

Applies to UX700 STD version.

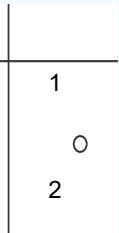
Connector	PIN	Function	Description
	1	Power Out	Power to Printer
	2	GND	Power ground

Power Port (DC-in or Printer) Applies to UX700 MDB version.

Connector	PIN	Function	Description
	1	+DC 9-43 V	External power from cable
	2	GND	Power ground
	3	WAKE	Signal
	4	Slave TX	Slave TX
	5	Slave RX	Slave RX
	6	MDB GND	Ground



Verifone, Inc.
Tel: 1-800-Verifone
www.verifone.com

UX700

Installation Guide

