

FCC Test Report

for

RFID Reader Module

Trade Name : Verifone
Model Number : UX301
Antenna Model No. : UX401
FCC ID : B32UX301SM
Report Number : RF-V040-1503-101
Date of Receipt : April 15, 2015
Date of Report : April 23, 2015

Prepared for

Verifone Inc.

1400 West Stanford Ranch Road, Suite 200, Rocklin, CA, 95765, UNITED STATES

Prepared by



Central Research Technology Co.

EMC Test Laboratory

11, Lane 41, Fushuen St., Jungshan Chiu, Taipei, Taiwan, 104, R.O.C.



NVLAP LAB CODE 200575-0

This report shall not be reproduced, except in full, without the written approval of Central Research Technology Co.. It may be duplicated completely in its entirety for legal use with the permission of the applicant. It should not be used to claim product endorsement by NVLAP, NIST or any U.S. government agency. The test result in the report applies only to the sample tested.

Verification

Equipment Under Test : RFID Reader Module
Model No. : UX301
Antenna Model No. : UX401
FCC ID : B32UX301SM
Applicant : Verifone Inc.
Address : 1400 West Stanford Ranch Road, Suite 200, Rocklin, CA,
95765, UNITED STATES
Applicable Standards : **FCC Part 15, Subpart C**
Date of Testing : April 15, 2015 ~ April 21, 2015
Deviation : N/A
Condition of Test Sample : Mass Production

We, **Central Research Technology Co.**, hereby certify that one sample of the designated product was tested in our facility during the period mentioned above. The test records, data evaluation and Equipment Under Test (EUT) configurations shown in the present report are true and accurate representation of the measurements of the sample's RF characteristics under the conditions herein specified.

The test results show that the EUT as described in the present report is in compliance with the requirements set forth in the standards mentioned above and apply to the tested sample identified in the present report only. The test report shall not be reproduced, except in its entirety, without the written approval of Central Research Technology Co.

PREPARED BY : Cathy Chen , **DATE** : April 23, 2015
(Cathy Chen/Technical Manager)

APPROVED BY : J. Y. Shih , **DATE** : Apr. 23, 2015
(Tsun-Yu Shih/General Manager)

Contents

1.	General Description	5
1.1	GENERAL DESCRIPTION OF EUT	5
1.2	TEST METHODOLOGY	6
1.3	TEST MODE	6
1.4	APPLIED STANDARDS	7
1.5	THE SUPPORT UNITS	10
1.6	LAYOUT OF SETUP	11
1.7	TEST CAPABILITY	12
1.8	MEASUREMENT UNCERTAINTY	14
2.	Conducted Emission Measurement	15
2.1	LIMITS FOR EMISSION MEASUREMENT	15
2.2	TEST INSTRUMENTS	16
2.3	TEST PROCEDURES	17
2.4	TEST CONFIGURATIONS	18
2.5	TEST DATA	19
3.	Field Strength of fundamental Measurement.....	23
3.1	APPLIED STANDARD	23
3.2	TEST INSTRUMENTS	24
3.3	MEASUREMENT PROCEDURE	25
3.4	TEST CONFIGURATION	26
3.5	TEST RESULTS	27
4.	Radiated Emission	31
4.1	APPLIED STANDARD	31
4.2	TEST INSTRUMENTS	32
4.3	MEASUREMENT PROCEDURE	33
4.4	TEST CONFIGURATION	34
4.5	TEST RESULTS	35
5.	Frequency Tolarence	37
5.1	APPLIED STANDARD	37
5.2	TEST INSTRUMENTS	38
5.3	MEASUREMENT PROCEDURE	39
5.4	TEST CONFIGURATION	39
5.5	TEST RESULTS	40
6.	20dB Bandwidth	44

6.1	APPLIED STANDARD	44
6.2	TEST INSTRUMENTS	44
6.3	MEASUREMENT PROCEDURE	45
6.4	TEST CONFIGURATION	45
6.5	TEST RESULTS	46
7.	Antenna Requirement	47
7.1	APPLIED STANDARD	47
7.2	ANTENNA TYPE	47
7.3	APPLICABLE RESULT	47

Attachment 1 – Photographs of the Test Configurations

Attachment 2 – External Photographs of EUT

Attachment 3 – Internal Photographs of EUT

1. General Description

1.1 General Description of EUT

Equipment Under Test	:	RFID Reader Module
Model No.	:	UX301
Antenna Model No:	:	UX401
Power in	:	8Vdc~43Vdc supplied by the power supply or adaptor
Test Voltage	:	120Vac/60Hz to the power adaptor/ DC power source
Frequency Range	:	13.56MHz
Channel Numbers	:	1
Function Modulation	:	ASK
Function Description	:	

The EUT is used to transmit and receive signal both. Please refer to the user's manual for the details.

Since the EUT shall be installed horizontally or vertically on the table, it was pre-tested on the two axis. Therefor only the test data of the worse case- vertical was used for Radiated test.

1.2 Test Methodology

For this E.U.T., the radiated emissions and conducted emission measurement performed according to the procedures illustrated in ANSI C63.4:2009 and other required are illustrated in separate sections of this test report for detail.

1.3 Test Mode

Continuous mode

1.4 Applied standards

(1) Field strength of Fundametal

According to 15.225(a), the field strength of any emissions within the band 13.553 - 13.567 MHz shall not exceed 15,848 microvolts/meter at 30 meters.

(2) Band Edge

According to 15.225(b), Within the bands 13.410-13.553 MHz and 13.567-13.710 MHz, the field strength of any emissions shall not exceed 334 microvolts/meter at 30 meters. According to 15.225(c), Within the bands 13.110-13.410 MHz and 13.710-14.010 MHz the field strength of any emissions shall not exceed 106 microvolts/meter at 30 meters.

(3) Radiation emission

According to 15.225(d), the field strength of any emissions appearing outside of the 13.110-14.010 MHz band shall not exceed the general radiated emission limits in § 15.209.

(4) Frequency tolerance

The frequency tolerance of the carrier signal shall be maintained within +/- 0.01% of the operating frequency over a temperature variation of -20 degrees to +50 degrees C at normal supply voltage, and for a variation in the primary supply voltage from 85% to 115% of the rated supply voltage at a temperature of 20 degrees C. For battery operated equipment, the equipment tests shall be performed using a new battery.

(5) Radiated emission limits, general requirements.

According to 15.209, except as provided elsewhere in this Subpart, the emissions from an intentional radiator shall not exceed the field strength levels specified in the following table:

Frequency (MHz)	Field Strength (uV/m)	Measurement Distance (m)
0.009 - 0.490	2400/F(kHz)	300
0.490 - 1.705	24000/F(kHz)	30
1.705 - 30.0	30	30
30 - 88	100 **	3
88 - 216	150 **	3
216 - 960	200 **	3
Above 960	500	3

** Except as provided in paragraph (g), fundamental emissions from intentional radiators operating under this Section shall not be located in the frequency bands 54-72 MHz, 76-88 MHz, 174-216 MHz or 470-806 MHz. However, operation within these frequency bands is permitted under other sections of this Part, e.g., Sections 15.231 and 15.241.

(6) 20dB Bandwidth

According to 15.215(c) requires the device must be designed to ensure that the 20 dB bandwidth of the emission, or whatever bandwidth may otherwise be specified in the specific rule section under which the equipment operates.

(7) Conduction Emission Requirement

For intentional device, according to §15.207(a) line conduction emission limit is as below table.

Frequency of Emission (MHz)	Conducted Limit (dBuV)	
	Quasi-peak	Average
0.15 – 0.5	66 to 56*	56 to 46*
0.5 - 5	56	46
5 - 30	60	50

* Decreases with the logarithm of the frequency.

(8) Restricted Band

Frequency (MHz)	Frequency (MHz)	Frequency (MHz)	Frequency (GHz)
0.090 - 0.110	16.42 - 16.423	399.9 - 410	4.5 - 5.15
¹ 0.495 - 0.505	16.69475 - 16.69525	608 - 614	5.35 - 5.46
² 1735 - 2.1905	16.80425 - 16.80475	960 - 1240	7.25 - 7.75
4.125 - 4.128	25.5 - 25.67	1300 - 1427	8.025 - 8.5
4.17725 - 4.17775	37.5 - 38.25	1435 - 1626.5	9.0 - 9.2
4.20725 - 4.20775	73 - 74.6	1645.5 - 1646.5	9.3 - 9.5
6.215 - 6.218	74.8 - 75.2	1660 - 1710	10.6 - 12.7
6.26775 - 6.26825	108 - 121.94	1718.8 - 1722.2	13.25 - 13.4
6.31175 - 6.31225	123 - 138	2200 - 2300	14.47 - 14.5
8.291 - 8.294	149.9 - 150.05	2310 - 2390	15.35 - 16.2
8.362 - 8.366	156.52475 - 156.52525	2483.5 - 2500	17.7 - 21.4
8.37625 - 8.38675	156.7 - 156.9	2690 - 2900	22.01 - 23.12
8.41425 - 8.41475	162.0125 - 167.17	3260 - 3267	23.6 - 24.0
12.29 - 12.293	167.72 - 173.2	3332 - 3339	31.2 - 31.8
12.51975 - 12.52025	240 - 285	3345.8 - 3358	36.43 - 36.5
12.57675 - 12.57725	322 - 335.4	3600 - 4400	(2)
13.36 - 13.41			

¹ Until February 1, 1999, this restricted band shall be 0.490-0.510 MHz.

² Above 38.6

(9) Antenna Requirement

An intentional radiator shall be designed to ensure that no antenna other than that furnished by the responsible party shall be used with the device. The use of a permanently attached antenna or of an antenna that uses a unique coupling to the intentional radiator shall be considered sufficient to comply with the provisions of this Section. The manufacturer may design the unit so that a broken antenna can be replaced by the user, but the use of a standard antenna jack or electrical connector is prohibited. This requirement does not apply to carrier current devices or to devices operated under the provisions of Sections 15.211, 15.213, 15.217, 15.219, or 15.221. Further, this requirement does not apply to intentional radiators that must be professionally installed, such as perimeter protection systems and some field disturbance sensors, or to other intentional radiators which, in accordance with Section 15.31(d), must be measured at the installation site. However, the installer shall be responsible for ensuring that the proper antenna is employed so that the limits in this Part are not exceeded.

1.5 The Support Units

N/A

1.6 Layout of Setup

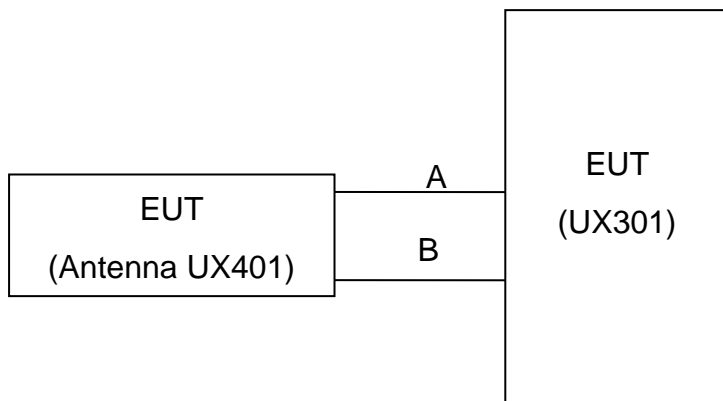

Connecting Cables :

No.	Cable	Length	Shielded	Core	Shielded Backshell	Supported by lab.
A	RJ45 Cable (CBL159-313-02-A)	0.6m	✓			
B	SMA Cable (CBL159-302-03-A)	0.5m	✓			

Justification:

For both conducted and radiated emission below 1GHz, the system was configured for typical fashion as a customer could use it normally.

For radiated emission, measurement of radiated emission from digital circuit is performed with normal transmitting.

1.7 Test Capability

Test Facility

The test facility used for evaluating the conformance of the EUT with each standard in the present report meets what required in CISPR16-1-4, CISPR16-2-3 and ANSI C63.4:2009.

Test Room	Type of Test Room	Descriptions
TR1	10m semi-anechoic chamber (23m×14m×9m)	Complying with the NSA requirements set in documents CISPR 22 and ANSI C63.4:2009. For the radiated emission measurement.
TR11	3m semi-anechoic chamber (9m × 6m × 6m)	
TR13	Test site	For the RF conducted emission measurement.
TR5	Shielding Room (8m×5m×4m)	For the conducted emission measurement.

Test Laboratory Competence Information

Central Research Technology Co. has been accredited / filed / authorized by the agencies listed in the following table.

Certificate	Nation	Agency	Code	Mark
Accreditation Certificate	USA	NVLAP	200575-0	ISO/IEC 17025
	R.O.C. (Taiwan)	TAF	0905	ISO/IEC 17025
	R.O.C. (Taiwan)	BSMI	SL2-IN-E-0033, SL2-IS-E-0033, SL2-R1/R2-E-0033, SL2-A1-E-0033 SL2-L1-E-0033	ISO/IEC 17025
Site Filing Document	USA	FCC	474046,TW1053	Test facility list & NSA Data
	Canada	IC	4699A-1,-3	Test facility list & NSA Data
	Japan	VCCI	R-1527,C-1609,C-4400,T-1441, T-1334, G-10, G-614	Test facility list & NSA Data
Authorization Certificate	Germany	TUV	UA50235497	ISO/IEC 17025
	Norway	Nemko	ELA 212	ISO/IEC 17025

The copy of each certificate can be downloaded from our web site: www.crc-lab.com

1.8 Measurement Uncertainty

The assessed measurement uncertainty with a suitable coverage factor K to ensure 95% confidence level for the normal distribution are shown as below, the values are less than U_{Cispr} in table 1 of CISPR 16-4-2.

Test Item	Measurement Uncertainty	
Radiated Emission: (30MHz~200MHz)	Horizontal: 3.9dB ; Vertical: 4.2dB	
Radiated Emission: (200MHz~1GHz)	Horizontal: 4.5dB ; Vertical: 5.7dB	
Conducted Emission	ESH2-Z5	3.3dB
	ENV 4200	3.1dB

2. Conducted Emission Measurement

Result: Pass

2.1 Limits for Emission Measurement

For intentional device, according to §15.207(a) line conduction emission limit is as below table.

Frequency of Emission (MHz)	Conducted Limit (dBuV)	
	Quasi-peak	Average
0.15 – 0.5	66 to 56*	56 to 46*
0.5 - 5	56	46
5 - 30	60	50

* Decreases with the logarithm of the frequency.

Note:

For a device with a permanent antenna operating at or below 30 MHz, the FCC will accept measurements done with a suitable dummy load, in lieu of the permanent antenna under the following conditions: (1) perform the AC line conducted tests with the permanent antenna to determine compliance with the Section 15.207 limits outside the transmitter's fundamental emission band; (2) retest with a dummy load in lieu of the permanent antenna to determine compliance with the Section 15.207 limits within the transmitter's fundamental emission band.

ji

2.2 Test Instruments

Test Site and Equipment	Manufacturer	Model No./ Serial No.	Last Calibration Date	Calibration Due Date
Test Receiver	R&S	ESCI/ 100316/003	March 30, 2015	March 30, 2016
LISN	R&S	ESH2-Z5/ 836613/001	Aug. 11, 2014	Aug. 11, 2015
2 nd LISN	EMCO	3816/2/ 29680	Nov. 26, 2014	Nov. 26, 2015
Balanced TELE. ISN	TESEQ	ISN T800/ 29432	Oct. 28, 2014	Oct. 28, 2015
RF Cable	JYBAO	0214/ C0112	March 11, 2015	Sept. 11, 2015
RF Cable	JYBAO	0214/ C0113	March 11, 2015	Sept. 11, 2015
Test Software	Audix	e3/ Ver. 6.110303a	NCR	NCR
TR4 shielded room	ETS LINDGREN	TR4/ 15353-E	NCR	NCR

Note:

1. The calibrations are traceable to NML/ROC.
2. NCR : No Calibration Required.

Instrument Setting

IF BW	Measurement Time	Detector	Trace	Comment
9kHz	1 second	Quasi-Peak / Average	Maxhold	

Climatic Condition

Ambient Temperature : 24°C; Relative Humidity : 37%

2.3 Test Procedures

- a. The EUT was set up per the test configuration figured in the next section of this chapter to simulate the typical usage per the user's manual.
- b. If the EUT is tabletop equipment, it was placed on a non-conducted table with a height of 0.8 meters above the reference ground plane and 0.4 meters from the conducting wall of the shielded room. Also if the EUT is floor-standing equipment, it was placed on a non-conducted support with a height of 12 millimeters above the reference ground plane.
- c. Connect the EUT's power source to the appropriate power mains through the LISN.
- d. All the other peripherals are connected to the 2nd LISN, if any.
- e. The LISN was placed 0.8 meters from the EUT and at least 0.8 meters from other units and other metal planes.
- f. Measure the conducted emissions on each power line (Neutral Line and Line 1 – Hot side) of the EUT's power source by using the test receiver connected to the coupling RF output port of LISN.
- g. Rapidly scan the signal from 150kHz to 30MHz by using the receiver through the Maximum-Peak detector to determine those frequencies associated with higher emission levels for each measured line.
- h. Then measure the maximum level of conducted disturbance for each frequency found from step g. by using the receiver through the Quasi-Peak and Average detectors per CISPR 16-1.
- i. Record the level for each frequency and compare with the required limit.

2.4 Test Configurations

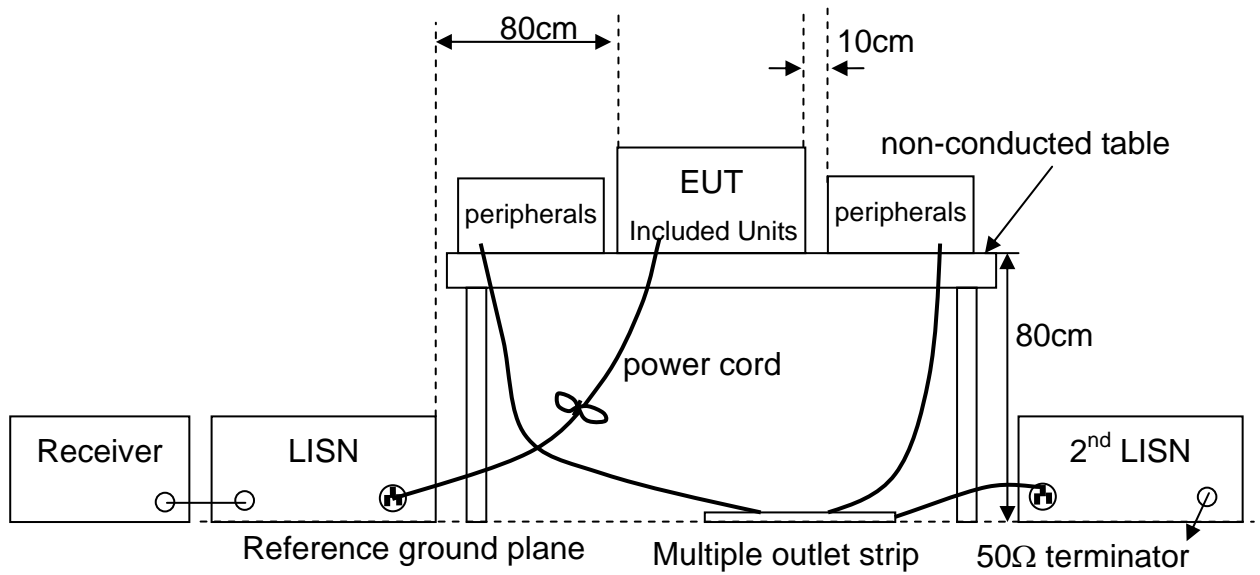

2.5 Test Data

Test Mode : Continuous Transmitting, with antenna
 Tester : Mathew Frequency Range : 150kHz~30MHz
 Phase : Line

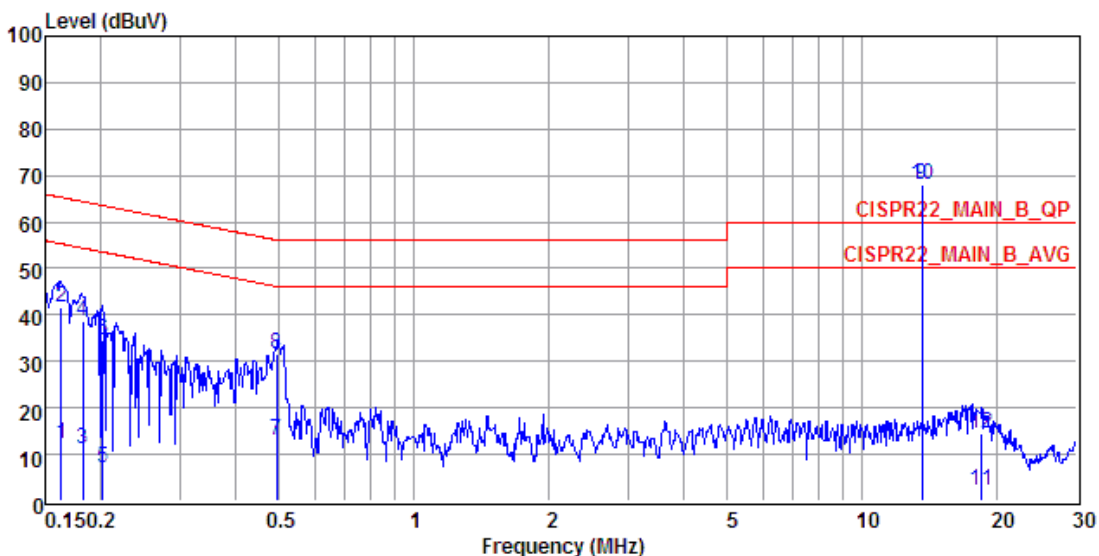

	Freq	Level	Factor	Read	Limit	Over		
	MHz	dBuV	dB	dBuV	dBuV	dB	Pol/Phase	Remark
1	0.163	12.15	10.29	1.86	55.31	-43.16	LINE	Average
2	0.163	41.82	10.29	31.53	65.31	-23.49	LINE	QP
3	0.182	11.07	10.29	0.78	54.40	-43.33	LINE	Average
4	0.182	38.78	10.29	28.49	64.40	-25.62	LINE	QP
5	0.202	7.06	10.29	-3.23	53.54	-46.48	LINE	Average
6	0.202	34.65	10.29	24.36	63.54	-28.89	LINE	QP
7	0.492	13.05	10.32	2.73	46.14	-33.09	LINE	Average
8	0.492	31.75	10.32	21.43	56.14	-24.39	LINE	QP
9 X	13.560	68.17	10.85	57.32	50.00	18.17	LINE	Average
10 X	13.560	68.05	10.85	57.20	60.00	8.05	LINE	QP
11	18.470	2.16	11.05	-8.89	50.00	-47.84	LINE	Average
12	18.470	14.35	11.05	3.30	60.00	-45.65	LINE	QP

Note:

1. Emission Level = reading value + correction factor.
2. Correction factor = cable loss + insertion loss of LISN.
3. Q.P. is abbreviation of quasi-peak.
4. 13.56MHz is main frequency, the signal can be ignored.

Test Mode : Continuous Transmitting, with dummy load
 Tester : Mathew Frequency Range : 150kHz~30MHz
 Phase : Line

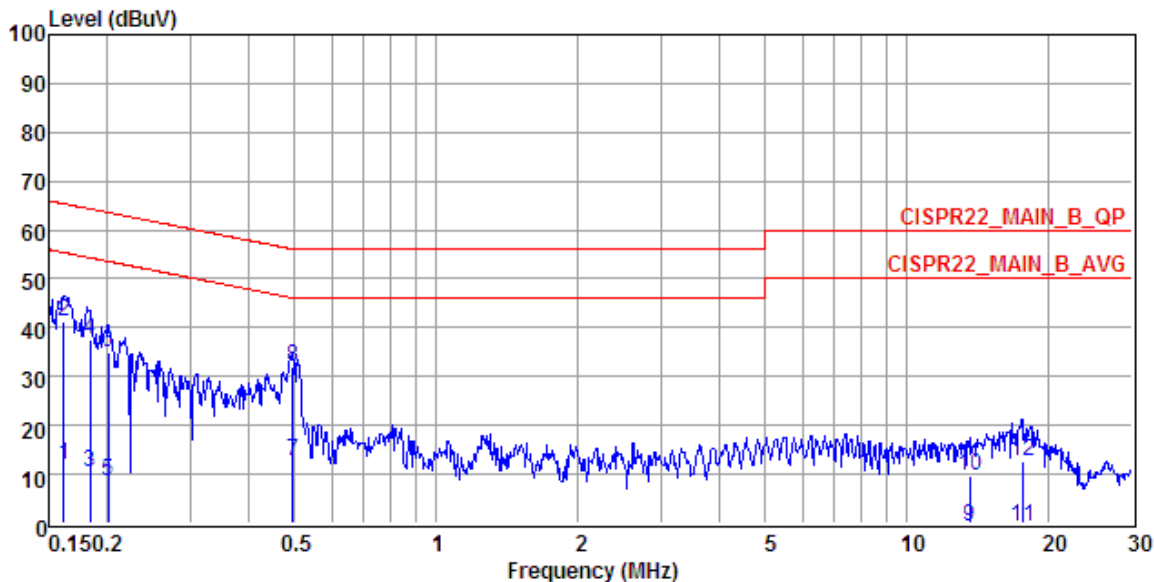

	Freq	Level	Factor	Read Level	Limit Line	Over Limit	Pol/Phase	Remark
	MHz	dBuV	dB	dBuV	dBuV	dB		
1	0.162	12.02	10.29	1.73	55.38	-43.36	LINE	Average
2	0.162	41.21	10.29	30.92	65.38	-24.17	LINE	QP
3	0.183	10.54	10.29	0.25	54.33	-43.79	LINE	Average
4	0.183	37.63	10.29	27.34	64.33	-26.70	LINE	QP
5	0.201	8.56	10.29	-1.73	53.58	-45.02	LINE	Average
6	0.201	34.98	10.29	24.69	63.58	-28.60	LINE	QP
7	0.494	12.63	10.32	2.31	46.10	-33.47	LINE	Average
8	0.494	32.13	10.32	21.81	56.10	-23.97	LINE	QP
9	13.560	-0.84	10.85	-11.69	50.00	-50.84	LINE	Average
10	13.560	9.83	10.85	-1.02	60.00	-50.17	LINE	QP
11	17.568	-0.73	11.01	-11.74	50.00	-50.73	LINE	Average
12	17.568	12.78	11.01	1.77	60.00	-47.22	LINE	QP

Note:

1. Emission Level = reading value + correction factor.
2. Correction factor = cable loss + insertion loss of LISN.
3. Q.P. is abbreviation of quasi-peak.

Test Mode : Continuous Transmitting, with antenna
 Tester : Mathew Frequency Range : 150kHz~30MHz
 Phase : Neutral

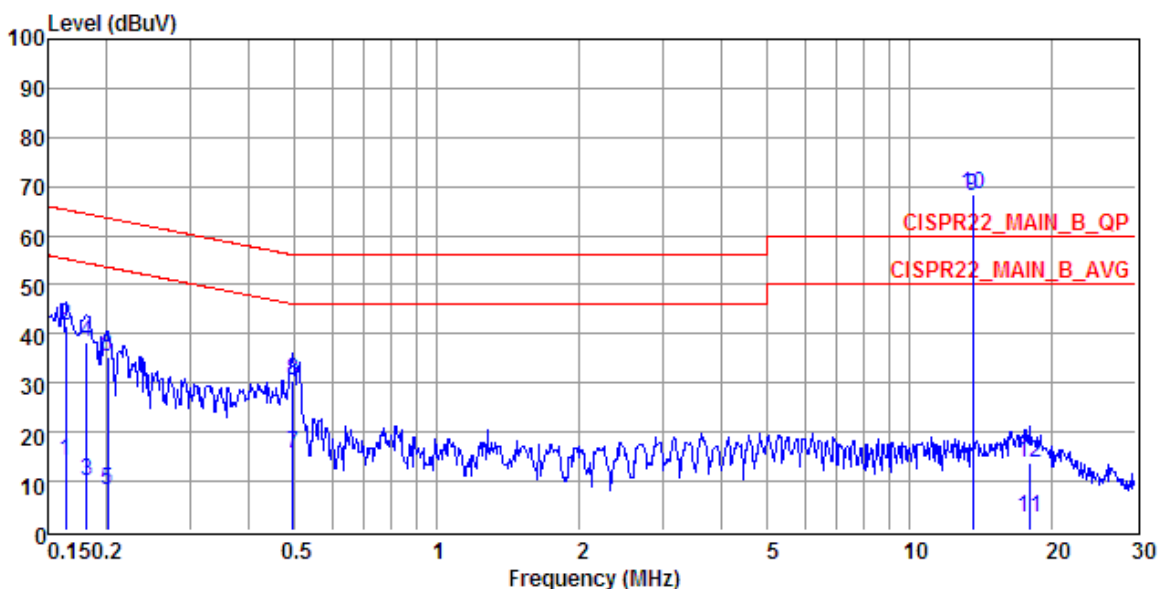

	Freq	Level	Factor	Read	Limit	Over	Pol/Phase	Remark
	MHz	dBuV	dB	dBuV	dBuV	dB		
1	0.163	13.94	10.30	3.64	55.30	-41.36	NEUTRAL	Average
2	0.163	41.73	10.30	31.43	65.30	-23.57	NEUTRAL	QP
3	0.182	10.01	10.30	-0.29	54.42	-44.41	NEUTRAL	Average
4	0.182	38.28	10.30	27.98	64.42	-26.14	NEUTRAL	QP
5	0.201	8.13	10.30	-2.17	53.58	-45.45	NEUTRAL	Average
6	0.201	35.20	10.30	24.90	63.58	-28.38	NEUTRAL	QP
7	0.494	15.71	10.33	5.38	46.10	-30.39	NEUTRAL	Average
8	0.494	30.54	10.33	20.21	56.10	-25.56	NEUTRAL	QP
9 X	13.560	68.04	10.95	57.09	50.00	18.04	NEUTRAL	Average
10 X	13.560	68.56	10.95	57.61	60.00	8.56	NEUTRAL	QP
11	17.849	2.55	11.14	-8.59	50.00	-47.45	NEUTRAL	Average
12	17.849	13.85	11.14	2.71	60.00	-46.15	NEUTRAL	QP

Note:

1. Emission Level = reading value + correction factor.
2. Correction factor = cable loss + insertion loss of LISN.
3. Q.P. is abbreviation of quasi-peak.
4. 13.56MHz is main frequency, the signal can be ignored.

Test Mode : Continuous Transmitting, with dummy load
 Tester : Mathew Frequency Range : 150kHz~30MHz
 Phase : Neutral

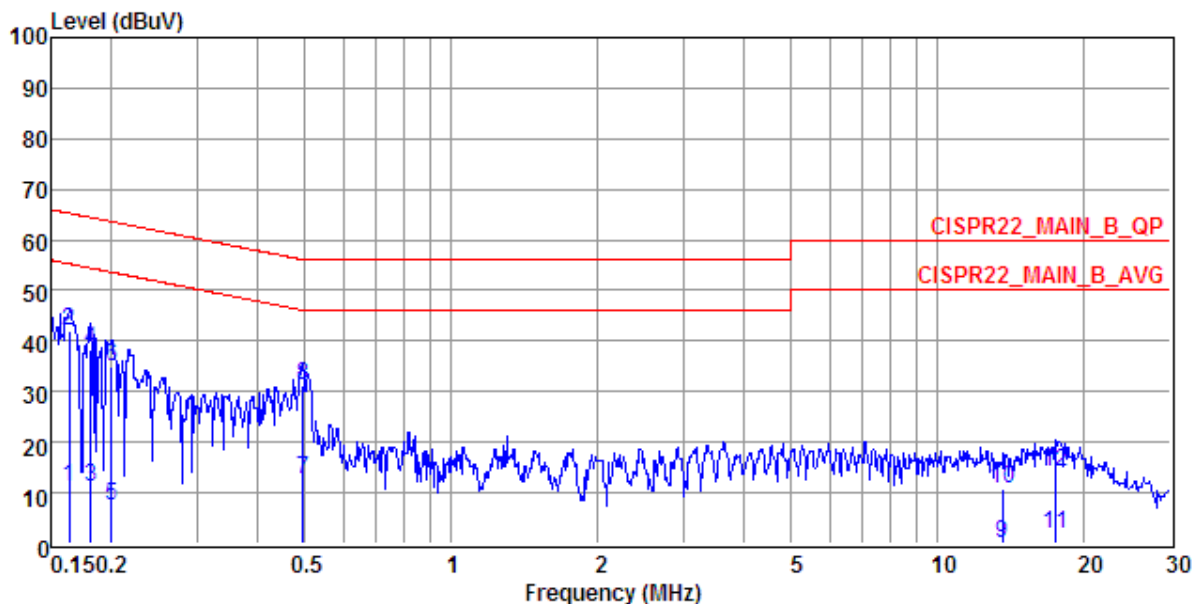

	Freq	Level	Factor	Read Level	Limit Line	Over Limit	Pol/Phase	Remark
	MHz	dBuV	dB	dBuV	dBuV	dB		
1	0.163	11.14	10.30	0.84	55.30	-44.16	NEUTRAL	Average
2	0.163	41.98	10.30	31.68	65.30	-23.32	NEUTRAL	QP
3	0.182	11.02	10.30	0.72	54.42	-43.40	NEUTRAL	Average
4	0.182	38.29	10.30	27.99	64.42	-26.13	NEUTRAL	QP
5	0.200	7.55	10.30	-2.75	53.62	-46.07	NEUTRAL	Average
6	0.200	34.92	10.30	24.62	63.62	-28.70	NEUTRAL	QP
7	0.494	12.79	10.33	2.46	46.10	-33.31	NEUTRAL	Average
8	0.494	31.38	10.33	21.05	56.10	-24.72	NEUTRAL	QP
9	13.551	-0.02	10.94	-10.96	50.00	-50.02	NEUTRAL	Average
10	13.551	10.95	10.94	0.01	60.00	-49.05	NEUTRAL	QP
11	17.475	1.98	11.13	-9.15	50.00	-48.02	NEUTRAL	Average
12	17.475	14.14	11.13	3.01	60.00	-45.86	NEUTRAL	QP

Note:

1. Emission Level = reading value + correction factor.
2. Correction factor = cable loss + insertion loss of LISN.
3. Q.P. is abbreviation of quasi-peak.

3. Field Strength of fundamental Measurement

Test Result : PASS

3.1 Applied Standard

According to 15.225(a), the field strength of any emissions within the band 13.553 – 13.567 MHz shall not exceed 15,848 microvolts/meter at 30 meters.

According to 15.225(b), within the bands 13.410-13.553 MHz and 13.567-13.710 MHz, the field strength of any emissions shall not exceed 334 microvolts/meter at 30 meters.

According to 15.225(c), within the bands 13.110-13.410 MHz and 13.710-14.010 MHz the field strength of any emissions shall not exceed 106 microvolts/meter at 30 meters.

3.2 Test Instruments

Test Site and Equipment	Manufacturer	Model No./ Serial No.	Last Calibration Date	Calibration Due Date
EMI Test Receiver	R&S	ESCI/ 100019	June 12, 2014	June 12, 2015
Loop Antenna	EMCO	6502/ 20558	Aug. 29, 2013	Aug. 29, 2015
RF Cable	N/A	N/A/ C0080	Feb. 10, 2015	Aug. 10, 2015
Test Software	Audix	e3/ ARD-SPR-000282	NCR	NCR
TR11 Semi – anechoic Chamber	ETS. LINDGREN	TR11/ 906-A	May 2, 2014	May 2, 2015

Note:

1. The calibrations are traceable to NML/ROC.
2. NCR : No Calibration Required.
3. The calibration date of the semi-anechoic chamber listed above is the date of NSA measurement.

Instrument Setting

RBW	VBW	Detector	Trace	Comment
9kHz	N/A	Peak	Maxhold	

Climatic Condition

Ambient Temperature : 24°C ; Relative Humidity : 51%

3.3 Measurement Procedure

- a. The EUT was set up per the test configuration figured in the next section of this chapter to simulate the typical usage per the user's manual.
- b. If the EUT is tabletop equipment, it should be placed on a wooden table with a height of 0.8 meters above the reference ground plane in the semi-anechoic chamber. If the EUT is floor-standing equipment, it should be placed on a non-conducted support with a height of 12 millimeters above the reference ground plane in the semi-anechoic chamber.
- c. The EUT is set at 3m away from the receiving antenna.
- d. Rapidly sweep the signal in the test frequency range by using the receiver through the Quasi-Peak detector.
- e. Rotate the EUT from 0° to 360° and position the receiving loop antenna at 1~4 meters above the reference ground plane to determine the fundamental frequency and and bandedge and record them.
- f. Then measure each frequency found from step e. by using the receiver with rotating the EUT and positioning the receiving antenna height to determine the maximum level.
- g. Finely tune the antenna and turntable around the recorded position of each frequency found from step e.
- h. Record and compare the maximum level with the required limit.
- i. Change the receiving antenna to another polarization to measure field strength of fundamental by following step d. to g. again.

3.4 Test Configuration

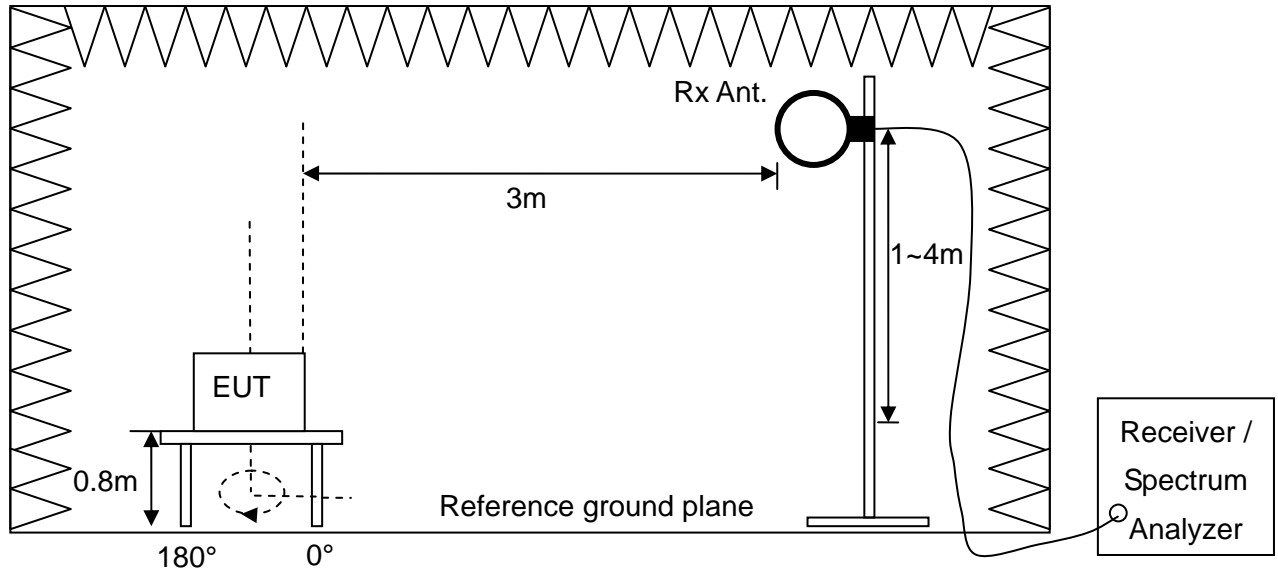

3.5 Test Results

Field strength of fundamental

Test Mode : Continuous Transmitting
 Tester : Jacky
 Polarization : Horizontal

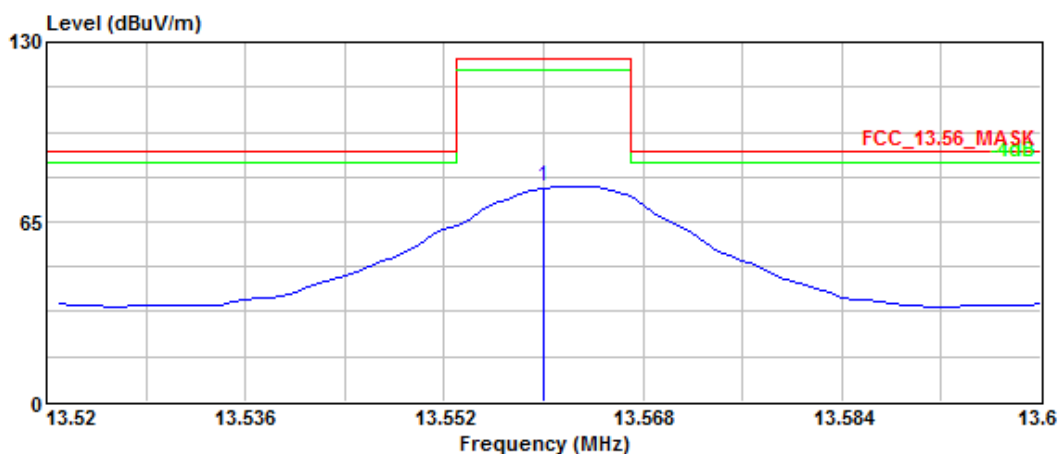

	Freq	Level	Read Level	Factor	Limit Line	Over Limit	Ant Pos	Table Pos	Pol/Phase	Remark
	MHz	dBuV/m	dBuV	dB/m	dBuV/m	dB	cm	deg		
1	13.560	77.85	66.84	11.01	124.00	-46.15	101	181	HORIZONTAL	Peak

Note :

1. Correction Factor (dB/m) = Cable Loss + Antenna Factor
2. Emission Level (dBuV/m) = Reading Data + Correction Factor
3. The limit is 15848 (uV/m)=84dBuV/m @ 30 m , for main frequency < 30MHz, the formula transfers the limit at 30 m to 3m is $L_{30}(dBuV/m) + 40 = 124$ dBuV/m
4. Margin (dB) = Limit – Emission Level

Test Mode : Continuous Transmitting
 Tester : Jacky
 Polarization : Vertical

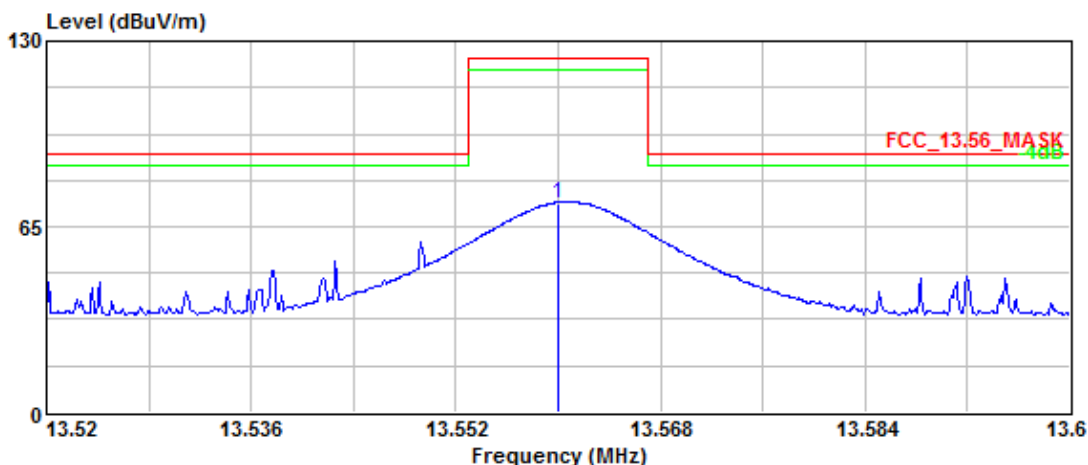

1	Freq	Level	Read	Limit	Over	Ant	Table	Pol/Phase	Remark
			Level	Line	Limit				
	MHz	dBuV/m	dBuV	dB/m	dBuV/m	dB	cm	deg	
1	13.560	72.71	61.70	11.01	124.00	-51.29	274	165	VERTICAL Peak

Note :

1. Correction Factor (dB/m) = Cable Loss + Antenna Factor
2. Emission Level (dBuV/m) = Reading Data + Correction Factor
3. The limit is 15848 (uV/m)=84dBuV/m @ 30m , for main frequency < 30MHz, the formula transfers the limit at 30m to 3m is $L_{30}(dBuV/m) + 40 = 124 dBuV/m$
4. Margin (dB) = Limit – Emission Level

Band Edge

Test Mode : Continuous Transmitting

Tester : Jacky

Polarization : Horizontal

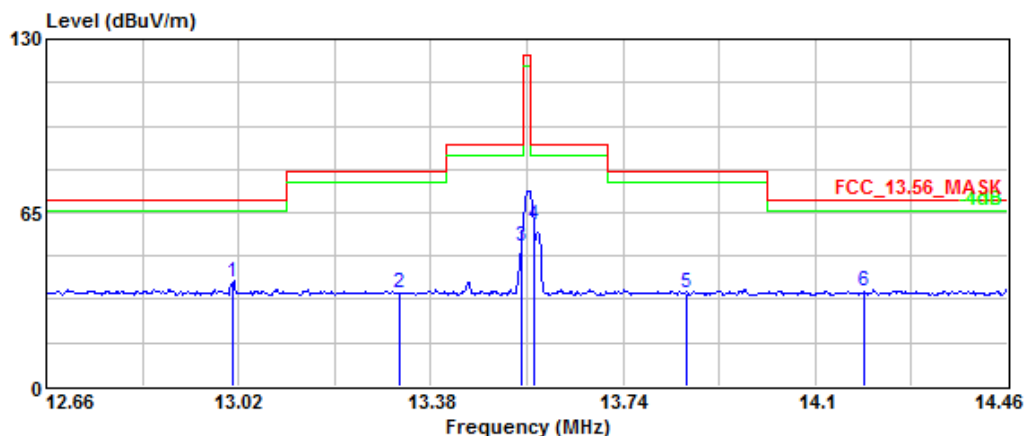

	Read	Limit	Over	Ant	Table				
Freq	Level	Level	Factor	Line	Limit	Pos	Pos	Pol/Phase	Remark
MHz	dBuV/m	dBuV	dB/m	dBuV/m	dB	cm	deg		
1	13.010	38.94	27.87	11.07	69.54	-30.60	128	223	HORIZONTAL Peak
2	13.320	34.77	23.74	11.03	80.51	-45.74	105	201	HORIZONTAL Peak
3	13.550	52.20	41.19	11.01	90.47	-38.27	108	117	HORIZONTAL Peak
4	13.572	60.48	49.47	11.01	90.47	-29.99	101	183	HORIZONTAL Peak
5	13.860	34.88	23.90	10.98	80.51	-45.63	102	178	HORIZONTAL Peak
6	14.190	35.19	24.25	10.94	69.54	-34.35	114	216	HORIZONTAL Peak

Note :

- Factor (dB/m) = Cable Loss + Antenna Factor
- Level (dBUV/m) = Read Level + Factor
- Over Limit (dB) = Level – Limit Line
- For main frequency < 30MHz, the formula transfers the limit at 30 m to 3m is $L_{30}(dBUV/m) + 40$

Test Mode : Continuous Transmitting

Tester : Jacky

Polarization : Vertical

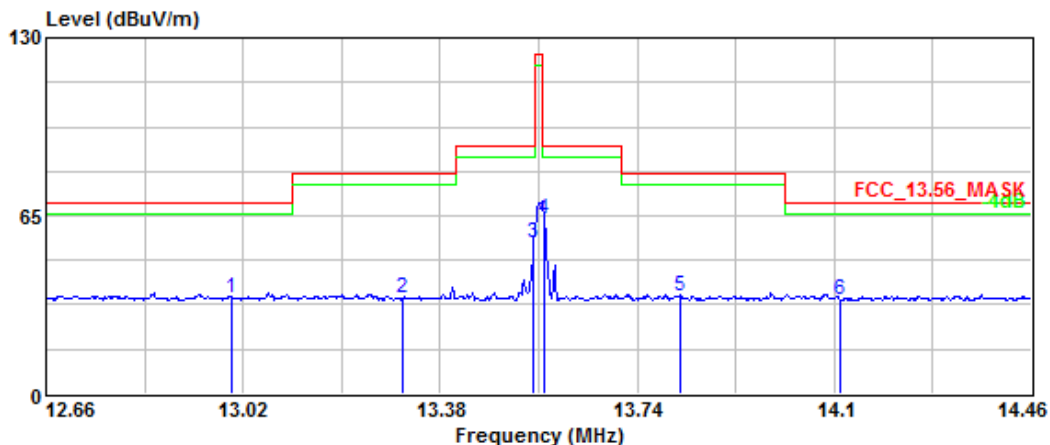

	Freq	Level	Read	Factor	Limit	Over	Ant	Table		
	MHz	dBuV/m	Level	dB/m	Line	Limit	Pos	Pos	Pol/Phase	Remark
			dBuV		dBuV/m	dB	cm	deg		
1	13.000	35.17	24.10	11.07	69.54	-34.37	239	7	VERTICAL	Peak
2	13.310	34.71	23.67	11.04	80.51	-45.80	208	304	VERTICAL	Peak
3	13.550	55.04	44.03	11.01	90.47	-35.43	268	198	VERTICAL	Peak
4	13.570	63.93	52.92	11.01	90.47	-26.54	257	190	VERTICAL	Peak
5	13.820	35.68	24.70	10.98	80.51	-44.83	190	196	VERTICAL	Peak
6	14.110	34.27	23.32	10.95	69.54	-35.27	215	80	VERTICAL	Peak

Note :

- Factor (dB/m) = Cable Loss + Antenna Factor
- Level (dBuV/m) = Read Level + Factor
- Over Limit (dB) = Level – Limit Line
- For main frequency < 30MHz, the formula transfers the limit at 30 m to 3m is $L_{30}(\text{dBuV/m}) + 40$

4. Radiated Emission

Test Result : PASS

4.1 Applied Standard

According to 15.225(d), The field strength of any emissions appearing outside of the 13.110-14.010 MHz band shall not exceed the general radiated emission limits in § 15.209.

Frequency (MHz)	Field Strength (uV/m)	Measurement Distance (m)
0.009 - 0.490	2400/F(kHz)	300
0.490 - 1.705	24000/F(kHz)	30
1.705 - 30.0	30	30
30 - 88	100 **	3
88 - 216	150 **	3
216 - 960	200 **	3
Above 960	500	3

** Except as provided in paragraph (g), fundamental emissions from intentional radiators operating under this Section shall not be located in the frequency bands 54-72 MHz, 76-88 MHz, 174-216 MHz or 470-806 MHz. However, operation within these frequency bands is permitted under other sections of this Part, e.g., Sections 15.231 and 15.241.

4.2 Test Instruments

Test Site and Equipment	Manufacturer	Model No./ Serial No.	Last Calibration Date	Calibration Due Date
EMI Test Receiver	R&S	ESCI/ 100019	June 12, 2014	June 12, 2015
Spectrum Analyzer	Agilent	E4407B/ MY45106795	May 29, 2014	May 29, 2015
Loop Antenna	EMCO	6502/ 20558	Aug. 29, 2013	Aug. 29, 2015
Bi-Log Antenna	EMCO	3142C/ 52088	May 14, 2014	May 14, 2015
Pre-Amplifier	Mini-circuit	ZKL-2/ 004	Feb. 10, 2015	Aug. 10, 2015
RF Cable	N/A	N/A/ C0080	Feb. 10, 2015	Aug. 10, 2015
TR11 Semi - anechoic Chamber	ETS. LINDGREN	TR11/ 906-A	May 2, 2014	May 2, 2015

Note:

1. The calibrations are traceable to NML/ROC.
2. NCR:No Calibration Required.
3. The calibration date of the semi-anechoic chamber listed above is the date of NSA measurement.

Instrument Setting

RBW	VBW	Detector	Trace	Comment
9kHz	N/A	Quasi-Peak	Maxhold	Below 30MHz
120kHz	N/A	Quasi-Peak	Maxhold	Below 1GHz

Climatic Condition

Ambient Temperature : 24°C; Relative Humidity : 51%

4.3 Measurement Procedure

- a. The EUT was set up per the test configuration figured in the next section of this chapter to simulate the typical usage per the user's manual.
- b. A software provided by client enabled the EUT to transmit and receive data at specified channel frequencies individually.
- c. If the EUT is tabletop equipment, it was placed on a non-conducted table with a height of 0.8 meters above the reference ground plane in the semi-anechoic chamber. If the EUT is floor-standing equipment, it was placed on a non-conducted support with a height of 12 millimeters above the reference ground plane in the semi-anechoic chamber.
- d. The EUT is set at 3m away from the interference receiving antenna.
- e. Rapidly sweep the signal in the test frequency range by using the spectrum through the Maximum-peak detector.
- f. Rotate the EUT from 0° to 360° and position the receiving antenna at heights from 1 to 4 meters above the reference ground plane continuously to determine at least six frequencies associated with higher emission levels and record them.
- g. For measurement of frequency above 1000MHz, the beamwidth of receiving horn antenna should keep covering EUT when the receiving horn antenna height varied.
- h. Then measure each frequency found from step e. by using the spectrum with rotating the EUT and positioning the receiving antenna height to determine the maximum level.
- i. Finely tune the antenna and turntable around the recorded position of each frequency found from step g.
- j. For measurement of frequency below 1000MHz, set the receiver detector to be Quasi-Peak per CISPR 16-1 to find out the maximum level occurred.
- k. For measurement of frequency above 1000MHz, set the spectrum detector to be Peak or Average to find out the maximum level occurred, if any.
- l. Record frequency, azimuth angle of the turntable, height, and polarization of the receiving antenna and compare the maximum level with the required limit.
- m. Change the receiving antenna to another polarization to measure radiated emission by following step e. to l. again.
- n. If the peak emission level measured from step e. is 4dB lower than the limit specified, then the emission values presented will be the peak value only. Otherwise, accurate Q.P. value will be measured and presented.

4.4 Test Configuration

Radiated Emission Measurement below 30MHz

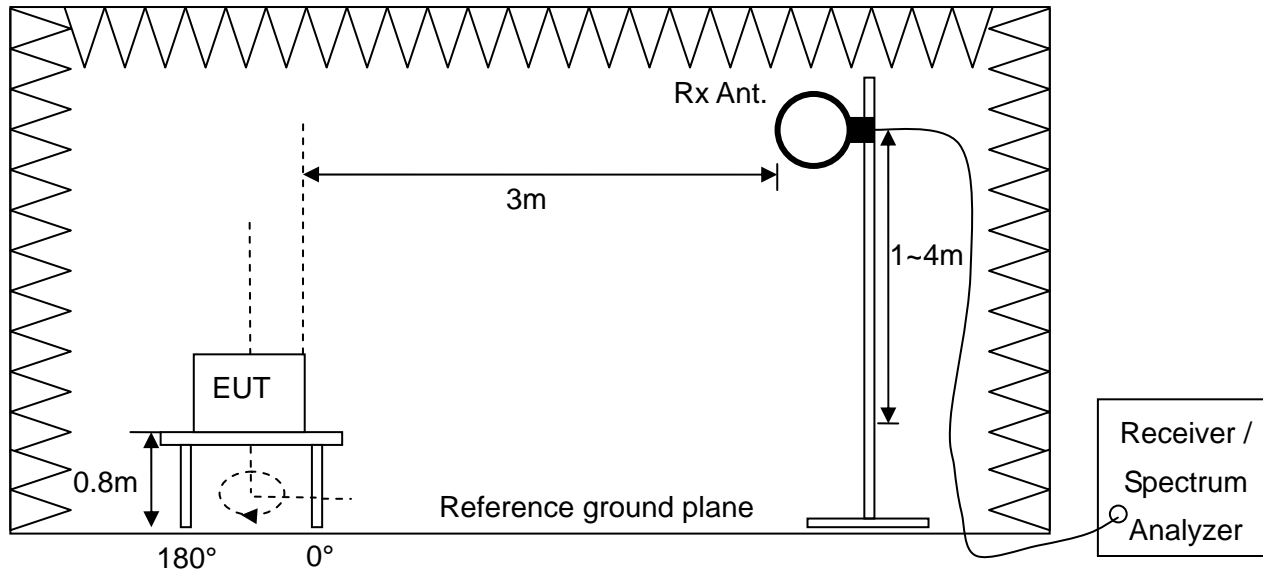

Radiated Emission Measurement above 30MHz

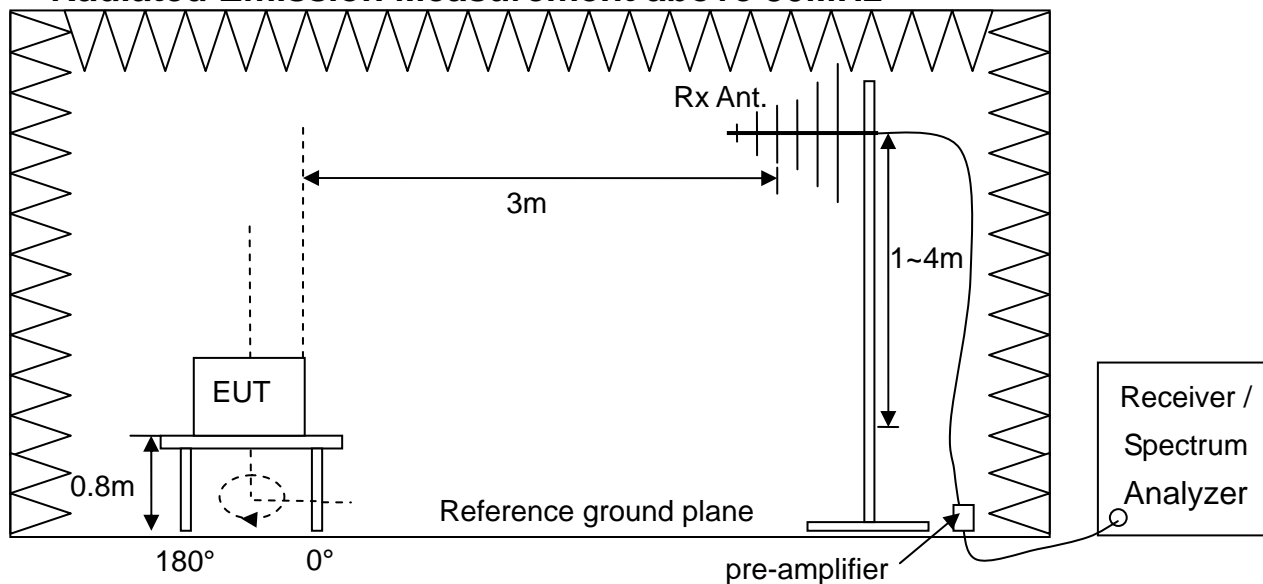

4.5 Test Results

Test Mode : Continuous Transmitting
 Tester : Jacky Frequency Range : 9kHz~1GHz
 Polarization : Horizontal

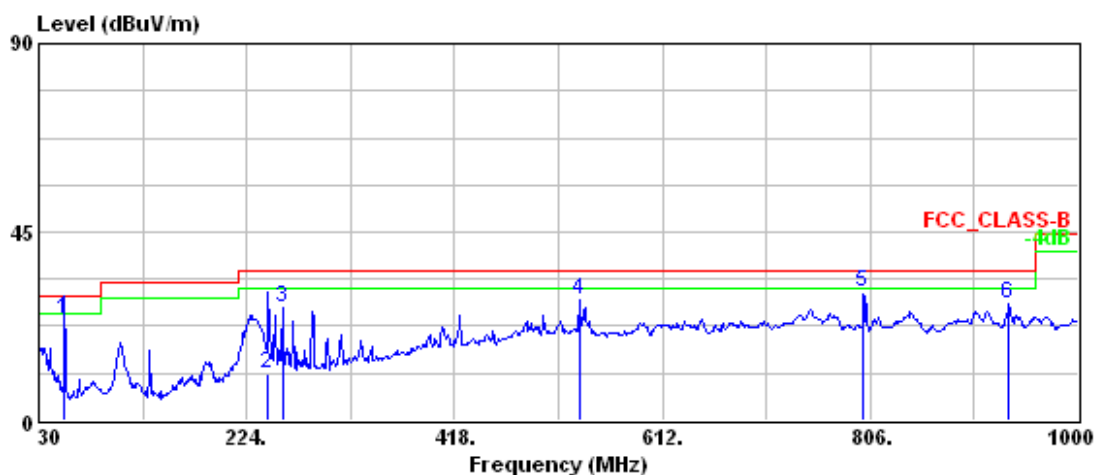

	Freq	Level	Read Level	Factor	Limit Line	Over Limit	Ant Pos	Table Pos	Pol/Phase	Remark
	MHz	dBuV/m	dBuV	dB/m	dBuV/m	dB	cm	deg		
1	54.238	24.19	49.31	-25.12	29.50	-5.31	167	197	HORIZONTAL	QP
2	244.380	11.33	32.03	-20.70	35.60	-24.27	125	154	HORIZONTAL	QP
3	257.880	26.74	46.03	-19.29	35.60	-8.86	---	---	HORIZONTAL	Peak
4	534.500	28.80	38.68	-9.88	35.60	-6.80	---	---	HORIZONTAL	Peak
5	799.977	30.51	40.66	-10.15	35.60	-5.09	114	144	HORIZONTAL	QP
6	934.900	27.95	32.93	-4.98	35.60	-7.65	---	---	HORIZONTAL	Peak

Note :

1. Correction Factor (dB/m) = Cable Loss + Antenna Factor – Gain of Preamplifier
2. Emission Level (dBuV/m) = Reading Data + Correction Factor

No signal can be detected from 9kHz to 30MHz, so the graphs are omitted below 30MHz.

Test Mode : Continuous Transmitting
 Tester : Jacky Frequency Range : 9kHz~1GHz
 Polarization : Vertical

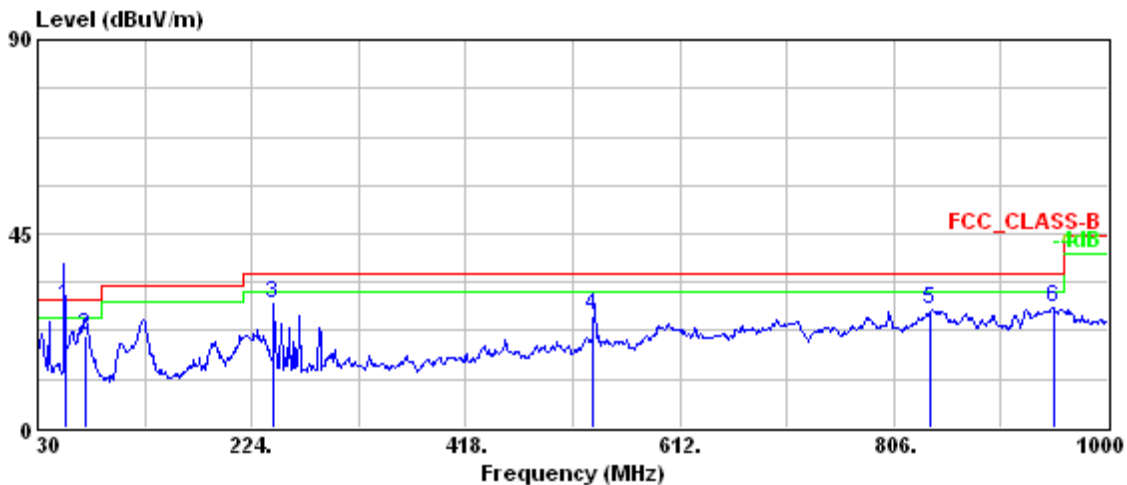

	Freq	Level	Read Level	Factor	Limit Line	Over Limit	Ant Pos	Table Pos	Pol/Phase	Remark
	MHz	dBuV/m	dBuV	dB/m	dBuV/m	dB	cm	deg		
1	54.575	28.21	49.42	-21.21	29.50	-1.29	106	173	VERTICAL	QP
2	73.023	21.17	46.11	-24.94	29.50	-8.33	100	170	VERTICAL	QP
3	244.380	28.66	46.61	-17.95	35.60	-6.94	---	---	VERTICAL	Peak
4	533.298	25.88	35.98	-10.10	35.60	-9.72	116	97	VERTICAL	QP
5	839.700	27.38	30.58	-3.20	35.60	-8.22	---	---	VERTICAL	Peak
6	950.300	28.06	30.06	-2.00	35.60	-7.54	---	---	VERTICAL	Peak

Note :

1. Correction Factor (dB/m) = Cable Loss + Antenna Factor – Gain of Pre-amplifier
2. Emission Level (dBuV/m) = Reading Data + Correction Factor

No signal can be detected from 9kHz to 30MHz, so the graphs are omitted below 30MHz.

5. Frequency Tolerance

Test Result : **PASS**

5.1 Applied Standard

According to 15.225(e), the frequency tolerance of the carrier signal shall be maintained within +/- 0.01% of the operating frequency over a temperature variation of -20 degrees to +50 degrees C at normal supply voltage, and for a variation in the primary supply voltage from 85% to 115% of the rated supply voltage at a temperature of 20 degrees C. For battery operated equipment, the equipment tests shall be performed using a new battery.

5.2 Test Instruments

Test Site and Equipment	Manufacturer	Model No./ Serial No.	Last Calibration Date	Calibration Due Date
Spectrum Analyzer	Agilent	E4405B/ MY45106706	May 23, 2014	May 23, 2015
Temperature Chamber	Terchy	MHG-800LF/ 920224	Aug. 14, 2014	Aug. 14, 2015
Adjustable DC Power Supply	instek	PSP-405/ C120177	NCR	NCR
Voltage Meter	FLUKE	187/ 91050091	July 4, 2014	July 4, 2016
Test Site	N.A.	TR13	NCR	NCR

Note:

1. The calibrations are traceable to NML/ROC.
2. NCR:No Calibration Required.

Instrument Setting

RBW	VBW	Detector	Trace	Comment
300Hz	1kHz	Peak	Maxhold	

Climatic Condition

Ambient Temperature : 25°C; Relative Humidity : 51%

5.3 Measurement Procedure

- a. The EUT was set up per the test configuration figured in the next section of this chapter to simulate the typical usage described in the user's manual supported by the manufacturer in test site TR13.
- b. Measure the frequency tolerance by using the spectrum analyzer and following the test conditions described in FCC 15.225(e) to perform the normal and extreme conditions test.
- c. Record the value and compare with the required limit.

5.4 Test Configuration

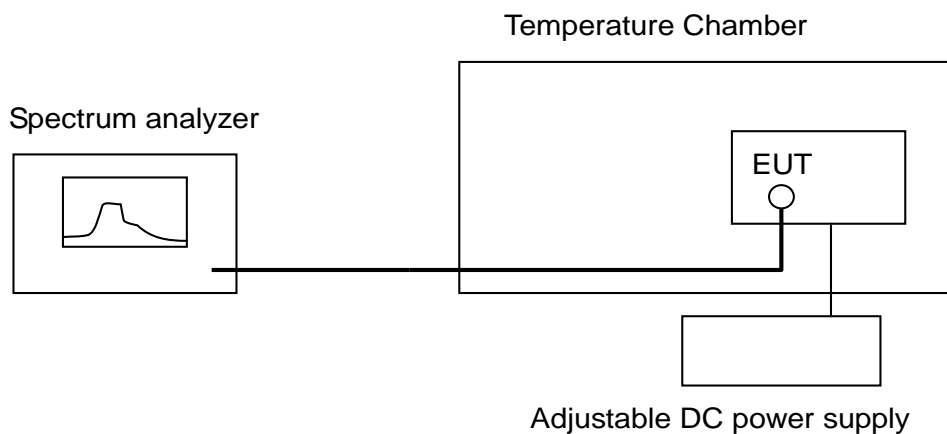

5.5 Test Results

Test Mode : Continuous Transmitting

Tester : Gary

Temperature (°C)	DC Voltage (Volt)	Meas. Frequency (MHz)	Deviation (kHz)	Limit (kHz)	Margin (kHz)
20°C	24.0	13.56067	N/A	N/A	N/A
	20.4	13.56067	0	1.356	1.356
	27.6	13.56067	0	1.356	1.356
-20°C	24.0	13.56075	0.08	1.356	1.276
50°C	24.0	13.56057	0.10	1.356	1.256

Note:

1. Deviation(kHz) = | Meas. Frequency – Meas. Frequency @20°C/24Vdc |
2. Margin (kHz)= Limit – Deviation
3. At the temperature control to highest and Lowest measurement, device turn on after temperature stability and measure at startup and at 2 mins, 5 mins, and 10 mins. Finally, record the worst on the report.
4. The test results of 8Vdc and 43Vdc are pass. The test data are omitted.

20°C, 24Vdc

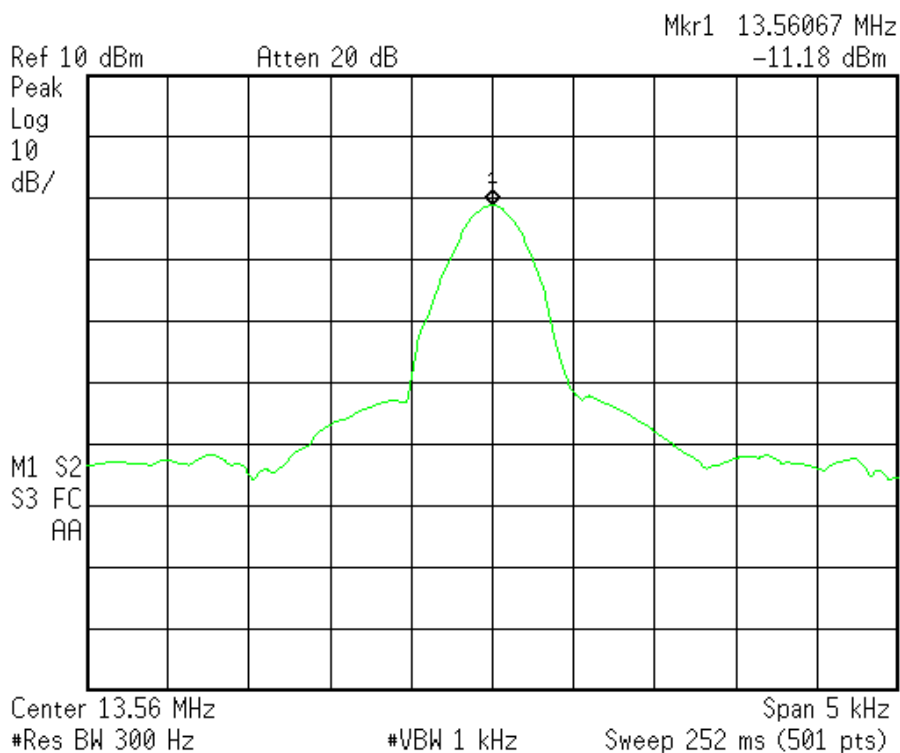

20°C, 20.4Vdc

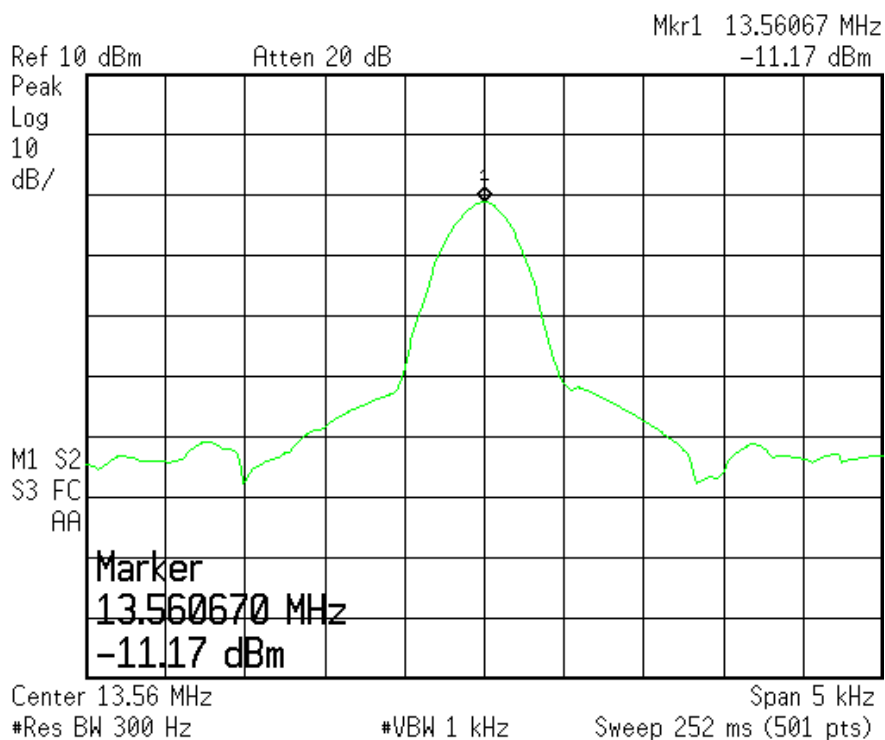

20°C, 27.6Vdc

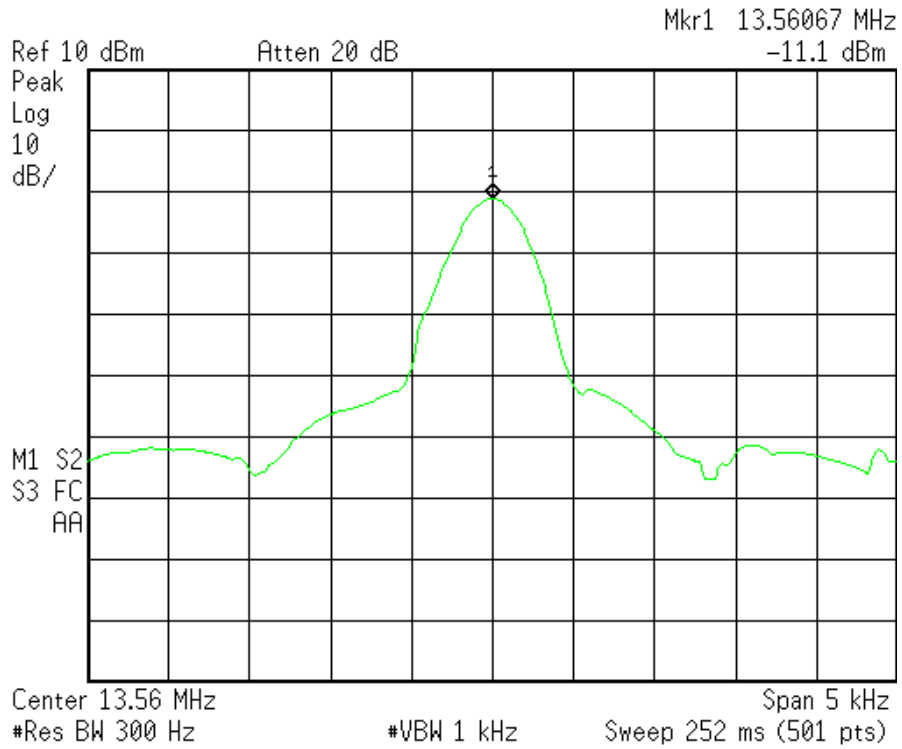

-20°C, 24Vdc

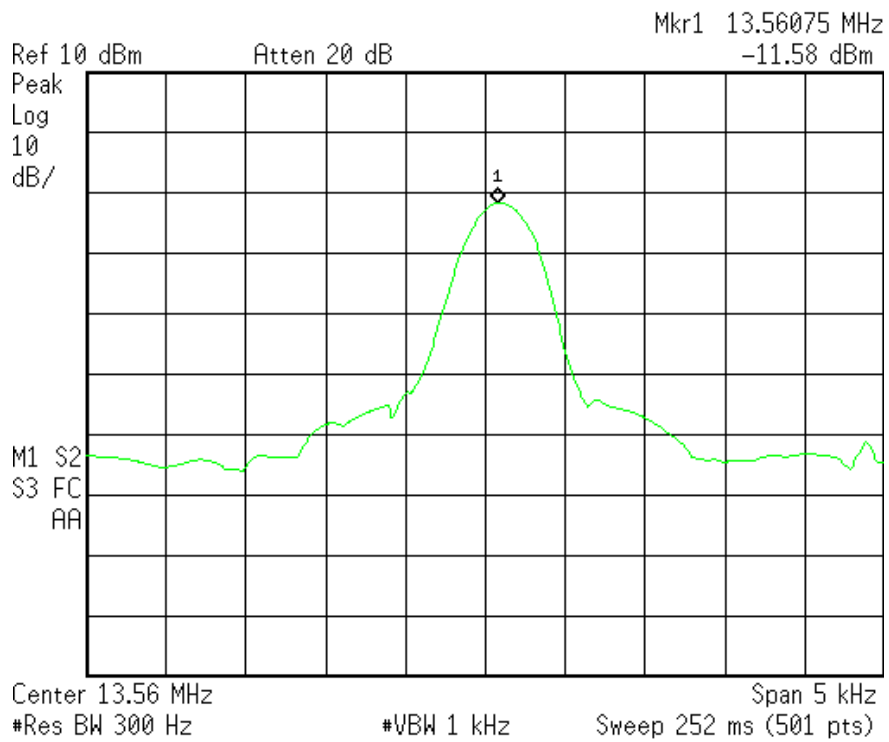

50°C, 24Vdc

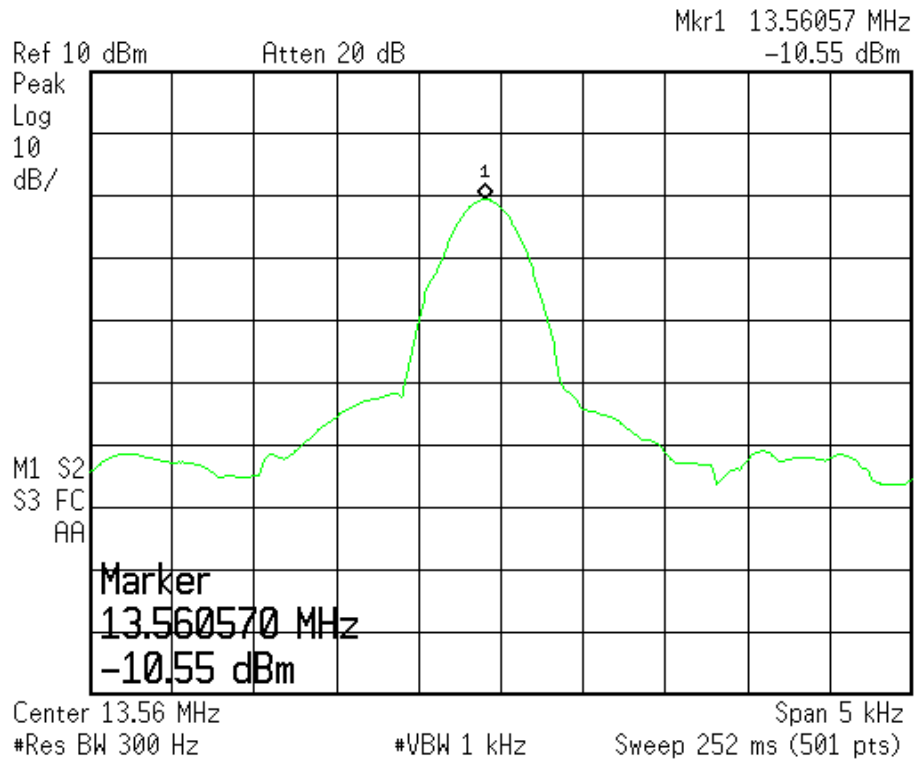

6. 20dB Bandwidth

Test Result : PASS

6.1 Applied Standard

According to 15.215(c) requires the device must be designed to ensure that the 20 dB bandwidth of the emission, or whatever bandwidth may otherwise be specified in the specific rule section under which the equipment operates.

According to 15.225, Operation should within the band 13.110 – 14.010 MHz.

6.2 Test Instruments

Test Site and Equipment	Manufacturer	Model No./ Serial No.	Last Calibration Date	Calibration Due Date
Spectrum Analyzer	Agilent	E4405B/ MY45106706	May 23, 2014	May 23, 2015
Test Site	N.A.	TR13	NCR	NCR

Note:

- 1.The calibrations are traceable to NML/ROC.
- 2.NCR : No Calibration Required.

Instrument Setting

RBW	VBW	Detector	Trace	Comment
300Hz	1kHz	Peak	Maxhold	

Climatic Condition

Ambient Temperature : 25°C; Relative Humidity : 51%

6.3 Measurement Procedure

- a. The EUT was set up per the test configuration figured in the next section of this chapter to simulate the typical usage described in the user's manual supported by the manufacturer in test site TR13.
- b. Measure the 20dB bandwidth by using the spectrum analyzer and following the test conditions described in FCC 15.215.
- c. Record the frequency and compare with the required limit.

6.4 Test Configuration



6.5 Test Results

Test Mode : Continuous Transmitting

Tester : Bill

Operating Frequency (MHz)	Limit (MHz)
13.56	13.110~14.01

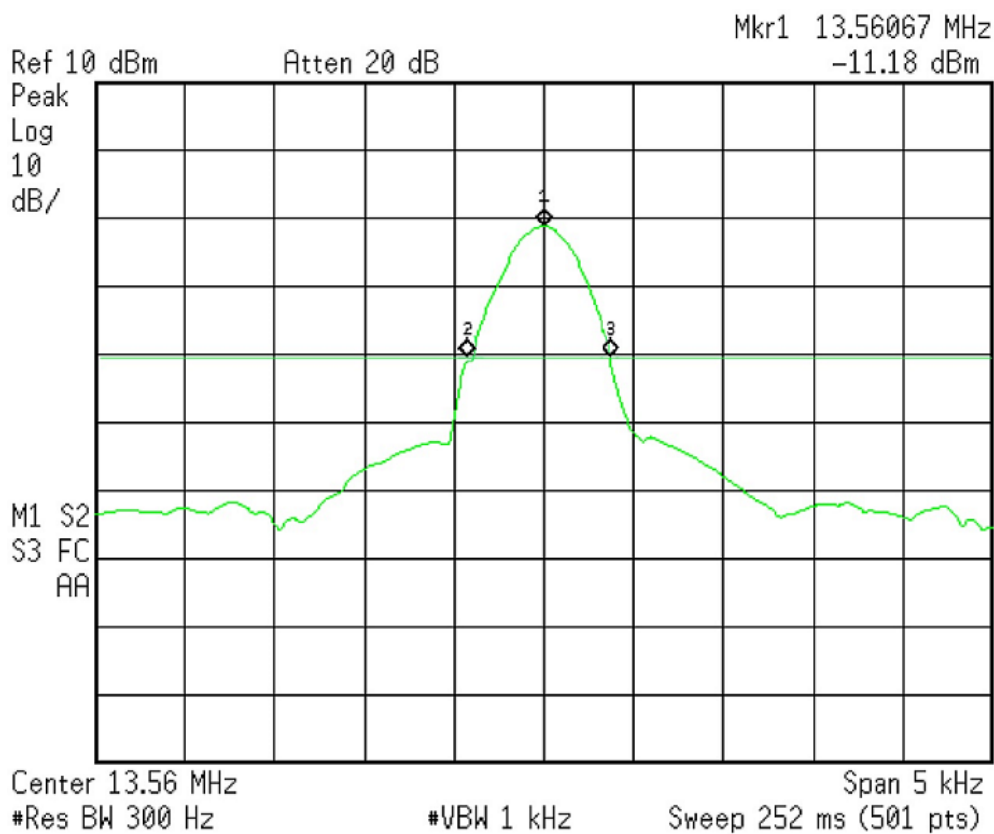

Marker	Trace	Type	X Axis	Amplitude
1	(1)	Freq	13.56067 MHz	-11.18 dBm
2	(1)	Freq	13.56025 MHz	-31.23 dBm
3	(1)	Freq	13.56104 MHz	-31.24 dBm

7. Antenna Requirement

7.1 Applied Standard

An intentional radiator shall be designed to ensure that no antenna other than that furnished by the responsible party shall be used with the device. The use of a permanently attached antenna or of an antenna that uses a unique coupling to the intentional radiator shall be considered sufficient to comply with the provisions of this Section. The manufacturer may design the unit so that a broken antenna can be replaced by the user, but the use of a standard antenna jack or electrical connector is prohibited. This requirement does not apply to carrier current devices or to devices operated under the provisions of Sections 15.211, 15.213, 15.217, 15.219, or 15.221. Further, this requirement does not apply to intentional radiators that must be professionally installed, such as perimeter protection systems and some field disturbance sensors, or to other intentional radiators which, in accordance with Section 15.31(d), must be measured at the installation site. However, the installer shall be responsible for ensuring that the proper antenna is employed so that the limits in this Part are not exceeded.

7.2 Antenna Type

The EUT use a permanently attached antenna

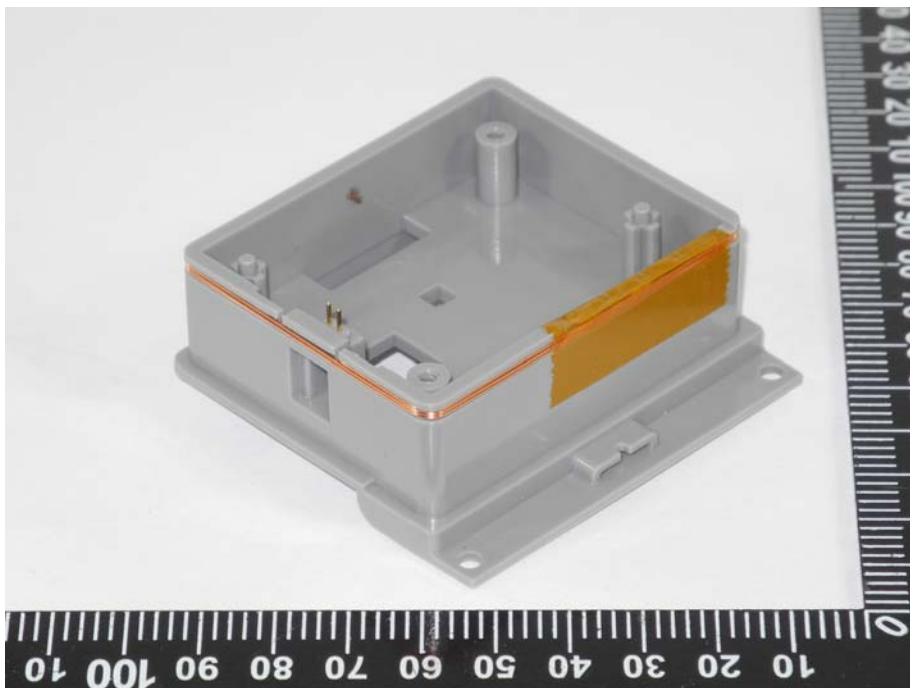

7.3 Applicable Result

Comply the requirement.