

REVISIONS			
REV	DESCRIPTION	DATE	APPR
A			

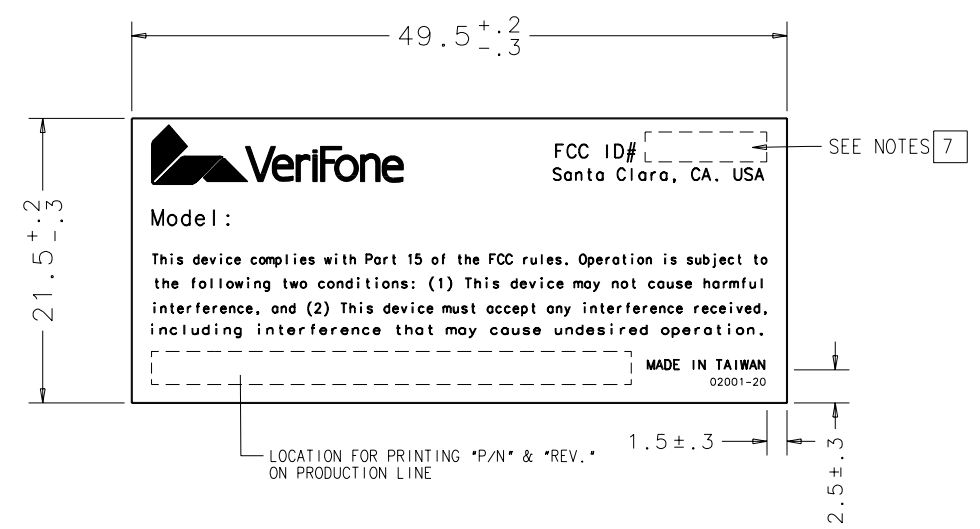

AFTER PRINTING ON PRODUCTION LINE

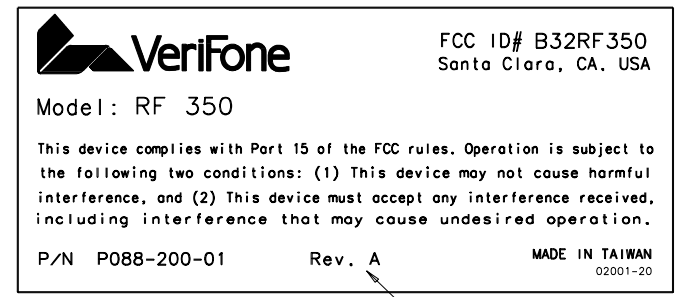

SHOULD BE CONSISTENT WITH THE BOM.

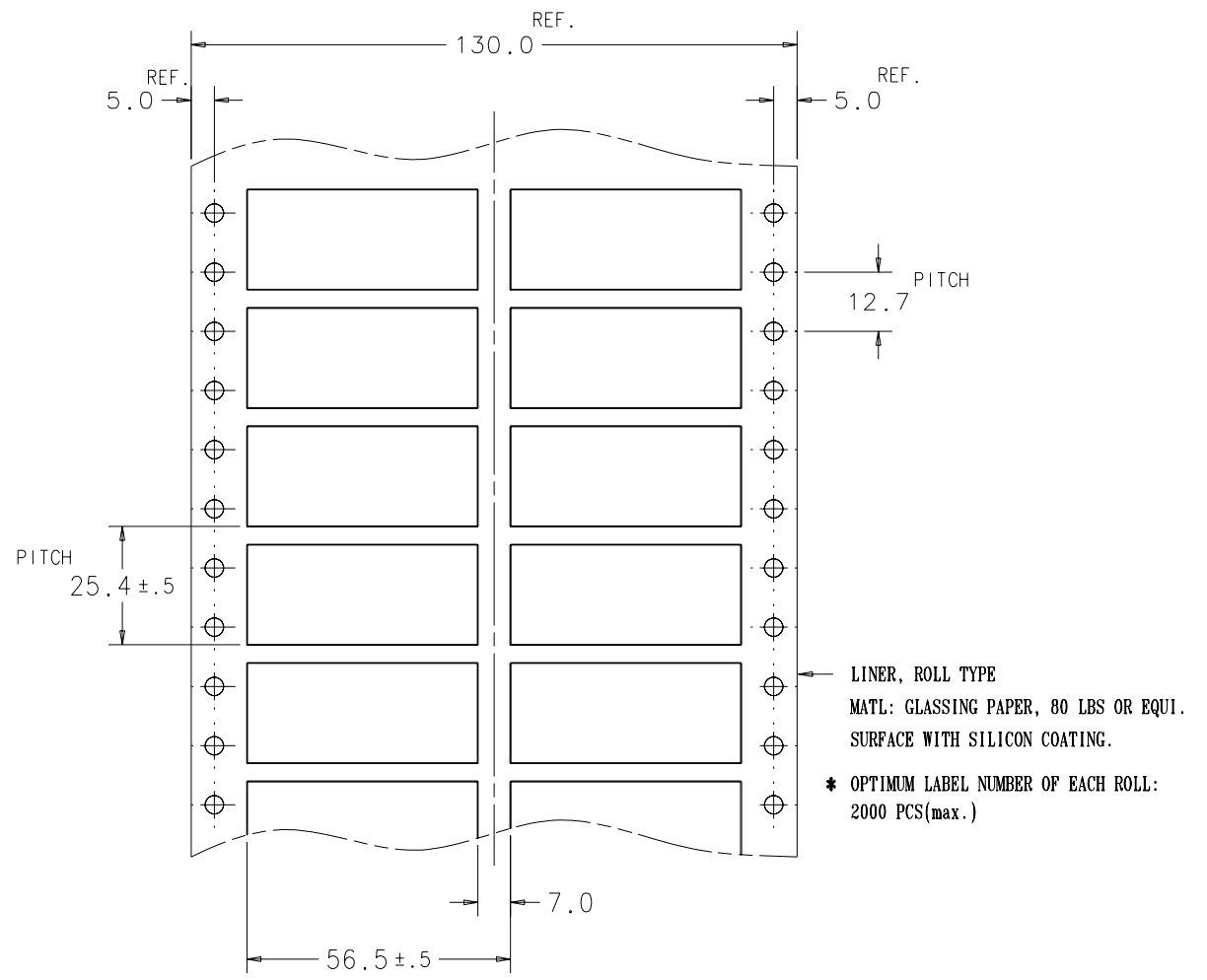

FIG.1 - LABEL AND LINER ASSY

NOTES

- MATL: WHITE SYNTHETIC PAPER(VINYL), 0.08mmTHK. (+/-10%)
- PRINT: PERMANENT BLACK OPAQUE INK.
- ADHESIVES: ACRYLIC, 3M #467 OR EQUIVALENT.
- FINISH: SURFACE WITH SILCRON COATING.
- LINER SPEC: ROLL TYPE, GLASSING PAPER, 80 LBS OR EQUIVALENT. SURFACE WITH SILICON COATING.
- REFER TO ARTWORK DWG. NO. 02002-20 FOR ACTUAL IMAGE.
- "P/N" & "REV. LEVEL", AND "FCC ID #" SHALL BE PRINTED ON THE PRODUCTION LINE.
- ALL TEXT PRINTED ON PRODUCTION LINE MUST BE CORRECT AND LEGIBLE.

© 1994 by VeriFone, Inc.
 VERIFONE, INC. OWNS THIS DOCUMENT AND THE CONFIDENTIAL AND PROPRIETARY INFORMATION CONTAINED THEREIN. WITHOUT THE PRIOR WRITTEN CONSENT OF VERIFONE, YOU MAY NOT DISCLOSE OR DUPLICATE THIS DOCUMENT, OR USE IT FOR ANY PURPOSE NOT AUTHORIZED BY VERIFONE.

SI - METRIC THIRD ANGLE PROJECTION INTERPRET DRAWING IN ACCORDANCE WITH ISO STANDARDS DO NOT SCALE THIS DRAWING DEBURR AND BREAK ALL SHARP EDGES UNLESS OTHERWISE SPECIFIED, DIMENSIONS ARE IN MILLIMETERS TOLERANCES: .X = ± .XX = ± ANGLES = ±	SIGNATURES	DATE	 LABEL, PROD ID RF350	C DRAWING NUMBER REV A
	PREPARED			
	CHECK			
	ENGR			
MODEL NAME			SCALE: NONE	SHEET 1 OF 1