

FCC Radio Test Report

FCC ID : B32P6302
Equipment : Point of Sales Terminal
Brand Name : Verifone
Model Name : P630-2
Applicant : Verifone, Inc.
1400 West Stanford Ranch Road Suite 150 Rocklin CA 95765 USA
Manufacturer : Verifone, Inc.
1400 West Stanford Ranch Road Suite 150 Rocklin CA 95765 USA
Standard : 47 CFR FCC Part 15.225

The product was received on Dec. 22, 2020, and testing was started from Dec. 22, 2020 and completed on Aug. 30, 2022. We, SPORTON INTERNATIONAL INC. Hsinhua Laboratory, would like to declare that the tested sample has been evaluated in accordance with the procedures given in ANSI C63.10-2013 and shown compliance with the applicable technical standards.

The test results in this report apply exclusively to the tested model / sample. Without written approval of SPORTON INTERNATIONAL INC. Hsinhua Laboratory, the test report shall not be reproduced except in full.



Approved by: Jackson Tsai

SPORTON INTERNATIONAL INC. Hsinhua Laboratory

No.52, Huaya 1st Rd., Guishan Dist., Taoyuan City 333411, Taiwan (R.O.C.)



Table of Contents

HISTORY OF THIS TEST REPORT3

SUMMARY OF TEST RESULT4

1 GENERAL DESCRIPTION5

1.1 Information.....5

1.2 Testing Applied Standards6

1.3 Testing Location Information6

1.4 Measurement Uncertainty6

2 TEST CONFIGURATION OF EUT.....7

2.1 Test Condition7

2.2 Test Channel Mode7

2.3 The Worst Case Measurement Configuration.....8

2.4 Accessories8

2.5 Support Equipment.....8

2.6 Test Setup Diagram9

3 TRANSMITTER TEST RESULT11

3.1 AC Power-line Conducted Emissions11

3.2 Emission Bandwidth.....13

3.3 Frequency Stability.....14

3.4 Field Strength of Fundamental Emissions and Spectrum Mask15

3.5 Transmitter Radiated Unwanted Emissions17

4 TEST EQUIPMENT AND CALIBRATION DATA.....20

APPENDIX A. TEST RESULTS OF AC POWER-LINE CONDUCTED EMISSIONS

APPENDIX B. TEST RESULTS OF EMISSION BANDWIDTH

APPENDIX C. TEST RESULTS OF TRANSMITTER RADIATED EMISSIONS

APPENDIX D. TEST RESULTS OF FREQUENCY STABILITY

APPENDIX E. TEST PHOTOS

PHOTOGRAPHS OF EUT v01



Summary of Test Result

Report Clause	Ref. Std. Clause	Test Items	Result (PASS/FAIL)	Remark
1.1.2	15.203	Antenna Requirement	PASS	-
3.1	15.207	AC Power-line Conducted Emissions	PASS	-
3.2	15.215(c)	Emission Bandwidth	PASS	-
3.3	15.225(e)	Frequency Stability	PASS	-
3.4	15.225(a)-(d)	Field Strength of Fundamental Emissions and Spectrum Mask	PASS	-
3.5	15.225(d)	Transmitter Radiated Unwanted Emissions	PASS	-

Declaration of Conformity:

The test results with all measurement uncertainty excluded are presented in accordance with the regulation limits or requirements declared by manufacturers.

Comments and explanations:

None

Reviewed by: Ben Tseng

Report Producer: Jenny Yang



1 General Description

1.1 Information

1.1.1 RF General Information

RF General Information					
Frequency Range(MHz)	Type	Mode	Ch. Frequency (MHz)	Channel Number	Field Strength (dBuV/m)
13.553 – 13.567	N/A	NFC	13.56	1	83.40

Note :

- ◆ Field strength performed peak level at 3m.
- ◆ Uses a ASK modulation.

1.1.2 Antenna Information

Ant.	Brand	Model Name	Antenna Type
1	N/A	N/A	Loop

1.1.3 EUT Information

Operational Condition	
EUT Power Type	From AC Adapter
Type of EUT	
<input checked="" type="checkbox"/>	Stand-alone
<input type="checkbox"/>	Combined (EUT where the radio part is fully integrated within another device) Combined Equipment - Brand Name / Model No.:
<input type="checkbox"/>	Plug-in radio (EUT intended for a variety of host systems) Host System - Brand Name / Model No.:
<input type="checkbox"/>	Other:

1.1.4 Test Signal Duty Cycle

Duty Cycle Operation Restriction			
The transmitter is used for		The transmitter is operated	
<input checked="" type="checkbox"/>	Inductive applications	<input checked="" type="checkbox"/>	Automatically triggered
<input type="checkbox"/>	Duty cycle fixed mode	<input checked="" type="checkbox"/>	Duty cycle random mode

1.2 Testing Applied Standards

According to the specifications of the manufacturer, the EUT must comply with the requirements of the following standards:

- 47 CFR FCC Part 15
- ANSI C63.10-2013

The following reference test guidance is not within the scope of accreditation of TAF:

- KDB 414788 D01 v01r01

1.3 Testing Location Information

Test Lab. : Sporton International Inc. Hsinhua Laboratory				
<input checked="" type="checkbox"/>	Hsinhua (TAF: 3785)	ADD: No.52, Huaya 1st Rd., Guishan Dist., Taoyuan City 333411, Taiwan (R.O.C.)		
		TEL: 886-3-327-3456	FAX: 886-3-327-0973	
Test site Designation No. TW3785 with FCC.				
Test Condition	Test Site No.	Test Engineer	Test Environment	Test Date
AC Conduction	CO04-HY	Daniel Lin	22.4~23.1°C / 54~67%	22/Dec/2020
RF Conducted	TH01-HY	Barry Hsiao	20.3~22.5°C / 51~55%	22/Dec/2020
Radiated	03CH03-HY	Edward Wang	22.3~24.6°C / 59~66%	30/Aug/2022
<input type="checkbox"/>	Wen 33rd.St. (TAF: 3785)	ADD: No.14-1, Ln. 19, Wen 33rd St., Guishan Dist., Taoyuan City 333010, Taiwan (R.O.C.)		
		TEL: 886-3-318-0787	FAX: 886-3-318-0287	
Test site Designation No. TW0008 with FCC.				

1.4 Measurement Uncertainty

ISO/IEC 17025 requires that an estimate of the measurement uncertainties associated with the emissions test results be included in the report. The measurement uncertainties given below are based on a 95% confidence level (based on a coverage factor (k=2))

Test Items	Uncertainty	Remark
Conducted Emission (150kHz ~ 30MHz)	0.9 dB	Confidence levels of 95%
Radiated Emission (9kHz ~ 30MHz)	2.4 dB	Confidence levels of 95%
Radiated Emission (30MHz ~ 1,000MHz)	3.7 dB	Confidence levels of 95%
Conducted Emission	1.0 dB	Confidence levels of 95%
Temperature	0.41 °C	Confidence levels of 95%
Humidity	3.4 %	Confidence levels of 95%



2 Test Configuration of EUT

2.1 Test Condition

Condition Item	Abbreviation/Remark	Remark
TnomVnom	Tnom	20°C
-	Vnom	120V
Freq. Stability	Abbreviation	Remark
-20°C	-	-
-10°C	-	-
0°C	-	-
10°C	-	-
20°C	-	-
30°C	-	-
40°C	-	-
50°C	-	-
20°C-138V	-	-
20°C-120V	-	-
20°C-102V	-	-

2.2 Test Channel Mode

Test Software Version	N/A
-----------------------	-----



Note: The EUT transmits RF signal continuously by itself

Mode	Power Setting
NFC	-
13.56MHz	default

2.3 The Worst Case Measurement Configuration

The Worst Case Mode for Following Conformance Tests	
Tests Item	AC power-line conducted emissions
Condition	AC power-line conducted measurement for line and neutral Test Voltage: 120Vac / 60Hz
Operating Mode	CTX
	1. Adapter Mode

The Worst Case Mode for Following Conformance Tests	
Tests Item	Emission Bandwidth, Frequency Stability
Test Condition	Conducted measurement

The Worst Case Mode for Following Conformance Tests			
Tests Item	Field Strength of Fundamental Emissions and Spectrum Mask Transmitter Radiated Unwanted Emissions		
Test Condition	Radiated measurement		
Operating Mode	CTX		
	1. Adapter Mode		
Orthogonal Planes of EUT	X Plane	Y Plane	Z Plane
			
Worst Planes of EUT	V		

2.4 Accessories

Reminder: Regarding to more detail and other information, please refer to user manual.

2.5 Support Equipment

Support Equipment – Conducted					
No.	Equipment	Brand Name	Model Name	FCC ID	Remark
1	AC Power Source	GW	APS-9102	-	-

2.6 Test Setup Diagram

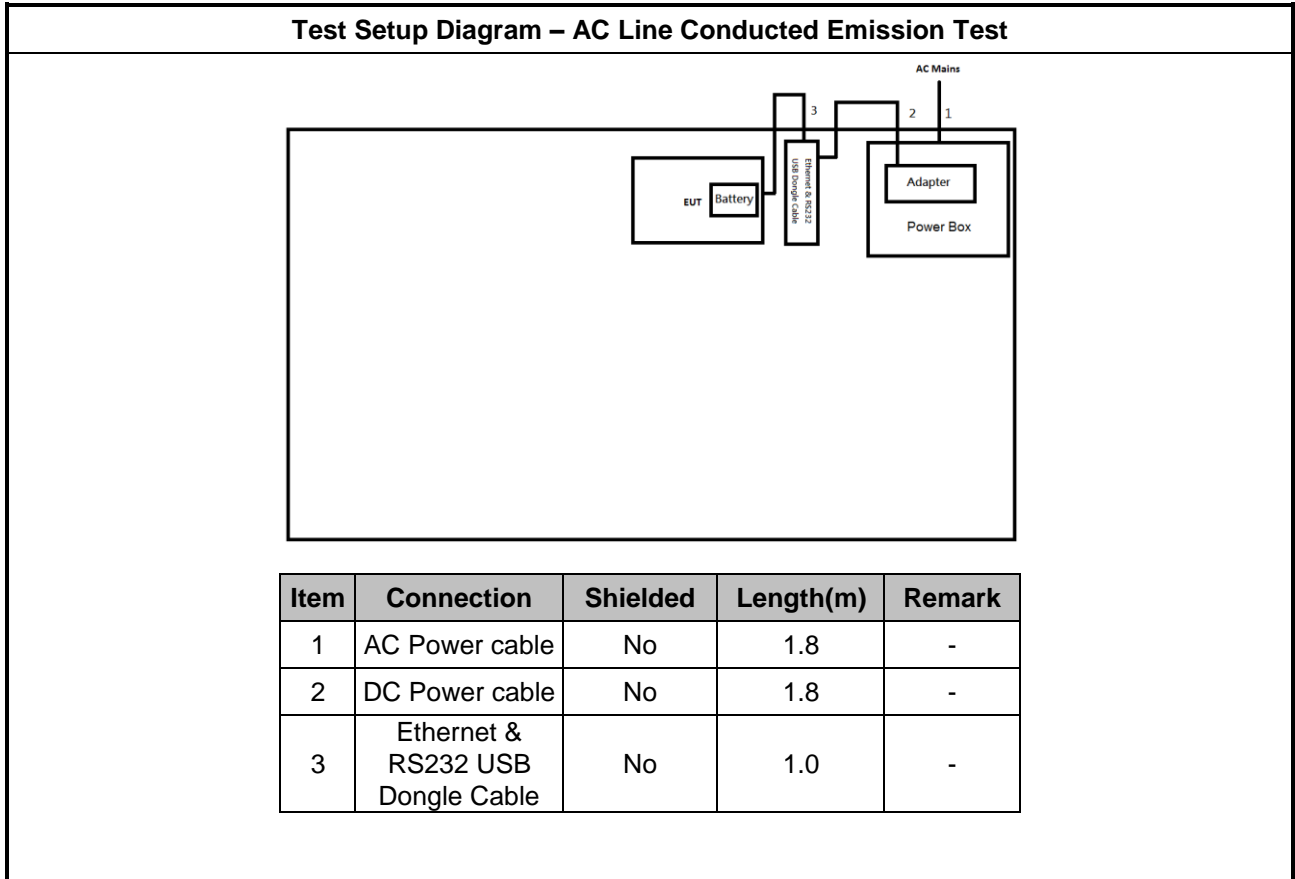

Test Setup Diagram - Radiated Test

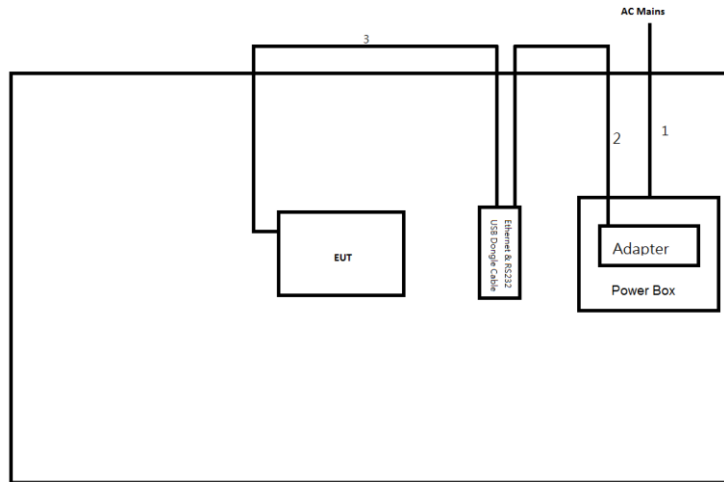

Item	Connection	Shielded	Length(m)	Remark
1	AC Power cable	No	1.8	-
2	DC Power cable	No	1.8	-
3	Ethernet & RS232 USB Dongle Cable	No	1.0	-

3 Transmitter Test Result

3.1 AC Power-line Conducted Emissions

3.1.1 AC Power-line Conducted Emissions Limit

AC Power-line Conducted Emissions Limit		
Frequency Emission (MHz)	Quasi-Peak	Average
0.15-0.5	66 - 56 *	56 - 46 *
0.5-5	56	46
5-30	60	50

Note 1: * Decreases with the logarithm of the frequency.

3.1.2 Measuring Instruments

Refer a test equipment and calibration data table in this test report.

3.1.3 Test Procedures

Test Method	
<input checked="" type="checkbox"/>	Refer as ANSI C63.10-2013, clause 6.2 for AC power-line conducted emissions.
<input checked="" type="checkbox"/>	If AC conducted emissions fall in operating band, then following below test method confirm final result.
<input type="checkbox"/>	Accept measurements done with a suitable dummy load replacing the antenna under the following conditions: (1) Perform the AC line conducted tests with the antenna connected to determine compliance with FCC 15.207 limits outside the transmitter's fundamental emission band; (2) Retest with a dummy load to determine compliance with FCC 15.207 limits within the transmitter's fundamental emission band.
<input checked="" type="checkbox"/>	For a device with a permanent antenna operating at or below 30 MHz, accept measurements done with a suitable dummy load, in lieu of the permanent antenna under the following conditions: (1) Perform the AC line conducted tests with the permanent antenna to determine compliance with the FCC 15.207 limits outside the transmitter's fundamental emission band; (2) Retest with a dummy load in lieu of the permanent antenna to determine compliance with the FCC 15.207 limits within the transmitter's fundamental emission band.

3.1.4 Measurement Results Calculation

The measured Level is calculated using:

Corrected Reading: Raw(Read Level) + LISN(LISN Factor) + CL(Cable Loss) + AT(Attenuator).

3.1.5 Test Setup

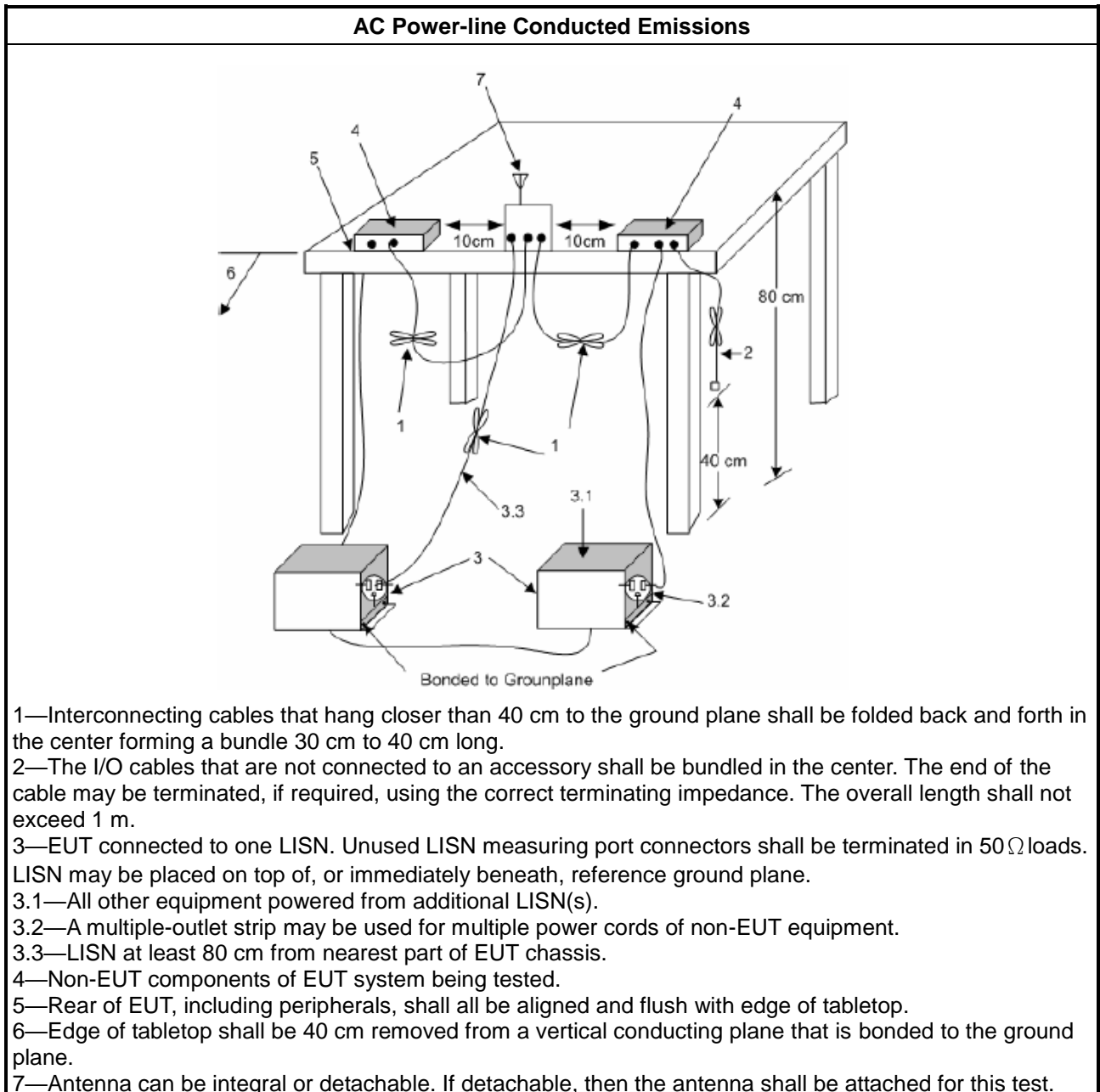

3.1.6 Test Result of AC Power-line Conducted Emissions

Refer as Appendix A

3.2 Emission Bandwidth

3.2.1 Emission Bandwidth Limit

20dB Bandwidth Limit	
<input checked="" type="checkbox"/>	Intentional radiators must be designed to ensure that the 20 dB bandwidth of the emissions in the specific band (13.553 – 13.567).

3.2.2 Measuring Instruments

Refer a test equipment and calibration data table in this test report.

3.2.3 Test Procedures

Test Method	
<input checked="" type="checkbox"/>	Because the measured signal is CW or CW-like adjusting the RBW per C63.10 would not be practical since measured bandwidth will always follow the RBW and the result will be approximately twice the RBW.
<input checked="" type="checkbox"/>	For radiated measurement. Loop antenna was rotated about the horizontal and vertical axis and the equipment to be measured and the test antenna shall be oriented to obtain the maximum emitted field strength level.

3.2.4 Test Setup

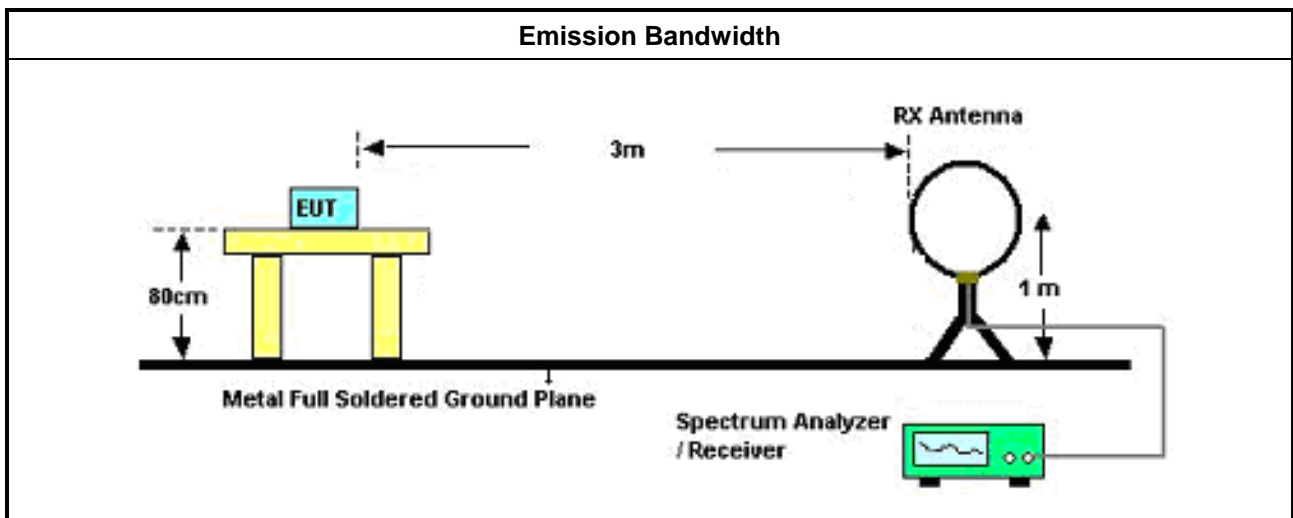

3.2.5 Test Result of Emission Bandwidth

Refer as Appendix B

3.3 Frequency Stability

3.3.1 Frequency Stability Limit

Frequency Stability Limit	
<input checked="" type="checkbox"/>	Carrier frequency stability shall be maintained to $\pm 0.01\%$ (± 100 ppm).

3.3.2 Measuring Instruments

Refer a test equipment and calibration data table in this test report.

3.3.3 Test Procedures

Test Method	
<input checked="" type="checkbox"/>	Refer as ANSI C63.10, clause 6.8 for frequency stability tests
<input checked="" type="checkbox"/>	Frequency stability with respect to ambient temperature
<input checked="" type="checkbox"/>	Frequency stability when varying supply voltage
<input type="checkbox"/>	For conducted measurement.
<input checked="" type="checkbox"/>	For radiated measurement. The equipment to be measured and the test antenna shall be oriented to obtain the maximum emitted power level.

3.3.4 Test Setup

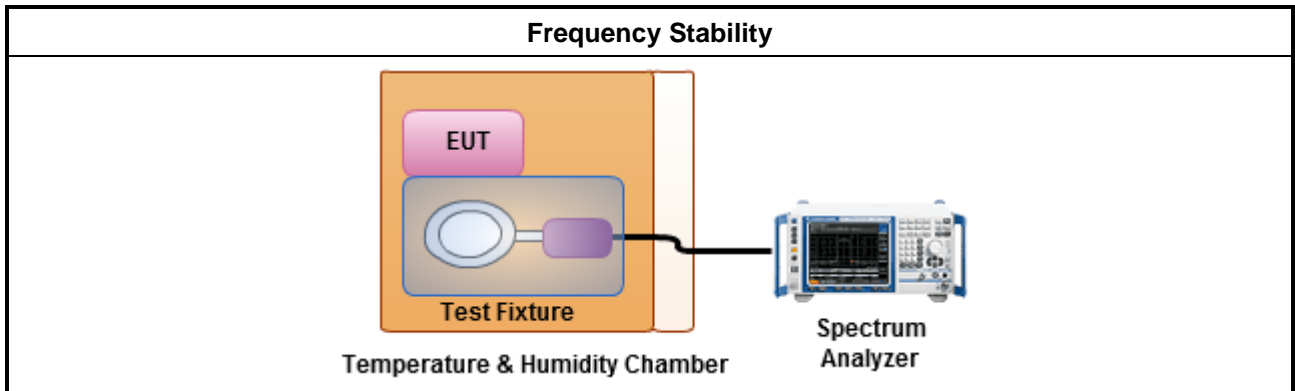

3.3.5 Test Result of Frequency Stability

Refer as Appendix D



3.4 Field Strength of Fundamental Emissions and Spectrum Mask

3.4.1 Field Strength of Fundamental Emissions and Spectrum Mask Limit

Field Strength of Fundamental Emissions and Spectrum Mask					
Emissions	(uV/m)@30m	(dBuV/m)@30m	(dBuV/m)@10m	(dBuV/m)@3m	(dBuV/m)@1m
fundamental	15848	84.0	103.1	124.0	143.1
Quasi peak measurement of the fundamental.					

3.4.2 Measuring Instruments

Refer a test equipment and calibration data table in this test report.

3.4.3 Test Procedures

Test Method	
<input checked="" type="checkbox"/>	Refer as ANSI C63.10, clause 6.4 for radiated emissions from below 30 MHz and test distance is 3m.
<input checked="" type="checkbox"/>	At frequencies below 30 MHz, measurements may be performed at a distance closer than that specified in the requirements; however, an attempt should be made to avoid making measurements in the near field. Pending the development of an appropriate measurement procedure for measurements performed below 30 MHz, when performing measurements at a closer distance than specified, the results shall be following below methods.
<input type="checkbox"/>	The results shall be extrapolated to the specified distance by making measurements at a minimum of two distances on at least one radial to determine the proper extrapolation factor.
<input checked="" type="checkbox"/>	The results shall be by using the square of an inverse linear distance extrapolation factor (40 dB/decade).
<input checked="" type="checkbox"/>	For radiated measurement. Loop antenna was rotated about the horizontal and vertical axis and the equipment to be measured and the test antenna shall be oriented to obtain the maximum emitted field strength level.

3.4.4 Measurement Results Calculation

The measured Level is calculated using:

Corrected Reading: Raw(Read Level) + AF(Antenna Factor) + CL(Cable Loss) - PA(Preamp Factor).

3.4.5 Test Setup

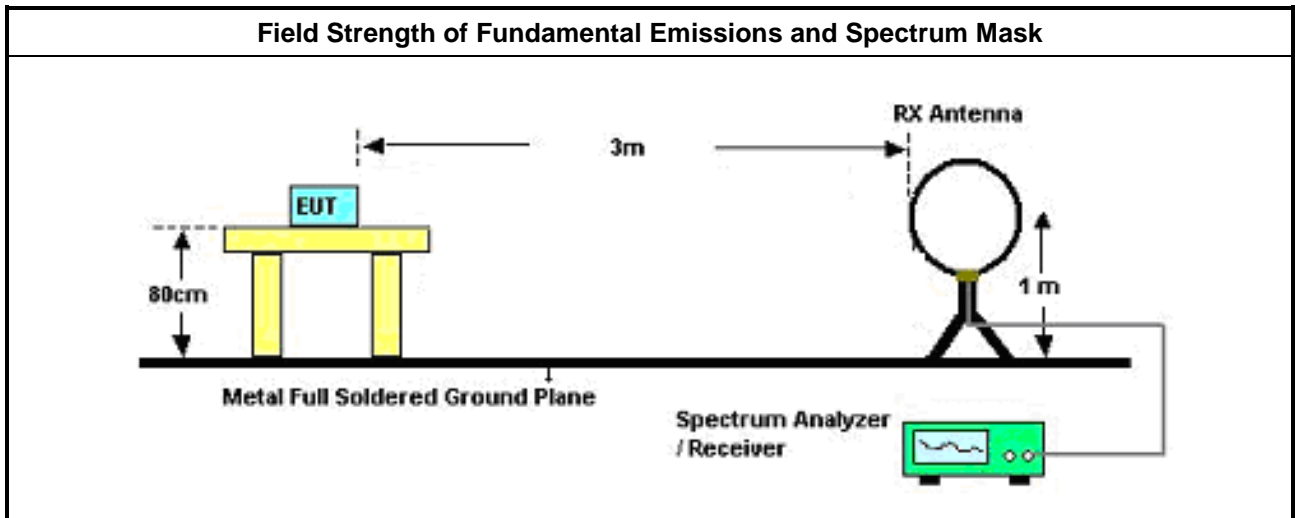

3.4.6 Test Result of Field Strength of Fundamental Emissions and Spectrum Mask

Refer as Appendix C



3.5 Transmitter Radiated Unwanted Emissions

3.5.1 Transmitter Radiated Unwanted Emissions Limit

Transmitter Radiated Unwanted Emissions Limit			
Frequency Range (MHz)	Field Strength (uV/m)	Field Strength (dBuV/m)	Measure Distance (m)
0.009~0.490	2400/F(kHz)	48.5 - 13.8	300
0.490~1.705	24000/F(kHz)	33.8 - 23	30
1.705~30.0	30	29	30
30~88	100	40	3
88~216	150	43.5	3
216~960	200	46	3
Above 960	500	54	3

Note 1: Test distance for frequencies at or above 30 MHz, measurements may be performed at a distance other than the limit distance provided they are not performed in the near field and the emissions to be measured can be detected by the measurement equipment. When performing measurements at a distance other than that specified, the results shall be extrapolated to the specified distance using an extrapolation factor of 20 dB/decade (inverse of linear distance for field-strength measurements, inverse of linear distance-squared for power-density measurements).

Note 2: Test distance for frequencies at below 30 MHz, measurements may be performed at a distance closer than the EUT limit distance; however, an attempt should be made to avoid making measurements in the near field. When performing measurements below 30 MHz at a closer distance than the limit distance, the results shall be extrapolated to the specified distance by either making measurements at a minimum of two or more distances on at least one radial to determine the proper extrapolation factor or by using the square of an inverse linear distance extrapolation factor (40 dB/decade). The test report shall specify the extrapolation method used to determine compliance of the EUT.

3.5.2 Measuring Instruments

Refer a test equipment and calibration data table in this test report.

3.5.3 Test Procedures

Test Method	
<input checked="" type="checkbox"/>	Refer as ANSI C63.10, clause 6.5 for radiated emissions from 30 MHz to 1 GHz and test distance is 3m.
<input checked="" type="checkbox"/>	Refer as ANSI C63.10, clause 6.4 for radiated emissions from below 30 MHz and test distance is 3m.
<input checked="" type="checkbox"/>	At frequencies below 30 MHz, measurements may be performed at a distance closer than that specified in the requirements; however, an attempt should be made to avoid making measurements in the near field. Pending the development of an appropriate measurement procedure for measurements performed below 30 MHz, when performing measurements at a closer distance than specified, the results shall be following below methods.
<input type="checkbox"/>	The results shall be extrapolated to the specified distance by making measurements at a minimum of two distances on at least one radial to determine the proper extrapolation factor.
<input checked="" type="checkbox"/>	The results shall be by using the square of an inverse linear distance extrapolation factor (40 dB/decade).
<input checked="" type="checkbox"/>	For radiated measurement. Loop antenna was rotated about the horizontal and vertical axis and the equipment to be measured and the test antenna shall be oriented to obtain the maximum emitted field strength level.
<input checked="" type="checkbox"/>	The any unwanted emissions level shall not exceed the fundamental emission level.
<input checked="" type="checkbox"/>	All amplitude of spurious emissions that are attenuated by more than 20 dB below the permissible value has no need to be reported.
<input checked="" type="checkbox"/>	KDB 414788 D01 v01r01 Open-Field Test Sites and Chamber Correlation Justification.
<input type="checkbox"/>	<ul style="list-style-type: none"> ▪ Based on FCC 15.31(f)(2): measurements may be performed at a distance closer than that specified in regulations; however, an attempt should be made to avoid making measurements in the near field.
<input type="checkbox"/>	<ul style="list-style-type: none"> ▪ Open-field site and chamber correlation testing had been performed and chamber measured test result is the worst case test result.

3.5.4 Measurement Results Calculation

The measured Level is calculated using:

Corrected Reading: Raw(Read Level) + AF(Antenna Factor) + CL(Cable Loss) - PA(Preamplifier Factor)

3.5.5 Test Setup

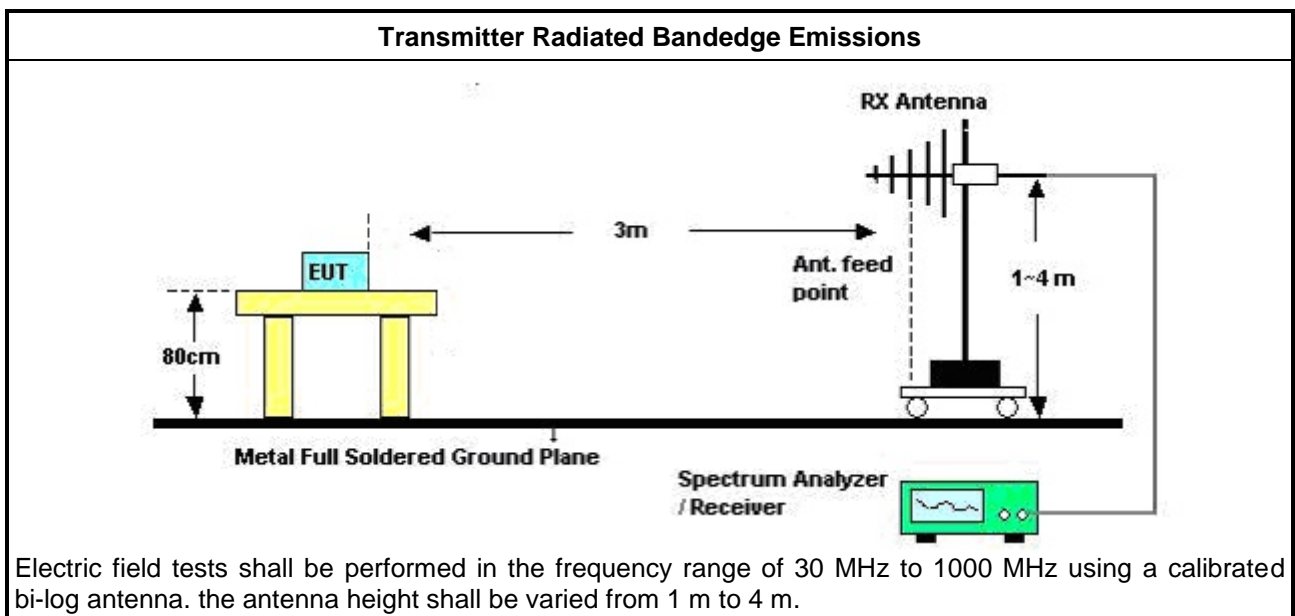
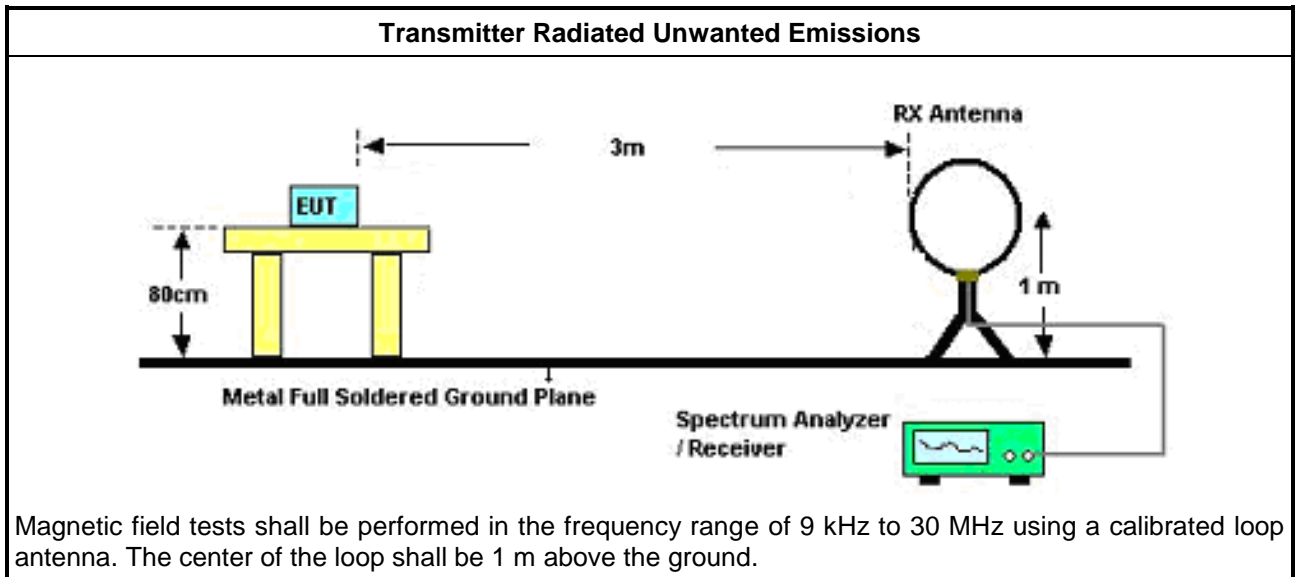

3.5.6 Transmitter Radiated Unwanted Emissions

Refer as Appendix C

4 Test Equipment and Calibration Data

Instrument for AC Conduction

Instrument	Manufacturer / Brand	Model No.	Serial No.	Characteristics	Calibration Date	Calibration Due Date
EMI Test Receiver	R&S	ESR3	102051	9kHz ~ 3.6GHz	29/May/2020	28/May/2021
LISN	R&S	ENV216	101295	9kHz ~ 30MHz	11/Nov/2020	10/Nov/2021
RF Cable-CON	MTJ	RG142	CB002-CO	9kHz ~ 200MHz	31/Aug/2020	30/Aug/2021
Impuls Begrenzer Pulse Limiter	SCHWARZBECK	VTSD 9561-F	9561-F041	9kHz ~ 30MHz	21/Sep/2020	20/Sep/2021

Instrument for Conducted Test

Instrument	Manufacturer / Brand	Model No.	Serial No.	Characteristics	Calibration Date	Calibration Due Date
Signal Analyzer	R&S	FSV 40	101013	10Hz~40GHz	19/Mar/2020	18/Mar/2021
Programmable Temp. & Humi. Chamber	Giant Force	GTH-225-20-SP-SD	MAA1112-007	-20~100°C	15/May/2020	14/May/2021

Instrument for Radiated Test

Instrument	Manufacturer / Brand	Model No.	Serial No.	Characteristics	Calibration Date	Calibration Due Date
3m Semi Anechoic Chamber	SIDT FRANKONIA	SAC-3M	03CH03-HY	30MHz~1GHz 3m	01/Aug/2022	31/Jul/2023
Signal Analyzer	R&S	FSV40	101500	10Hz~40GHz	12/Oct/2021	11/Oct/2022
Amplifier	HP	8447D	2944A08033	10kHz~1.3GHz	08/Apr/2022	07/Apr/2023
Bilog Antenna & 6dB Attenuator	SCHAFFNER / EMC1	CBL6112B / N-6-05	22237 / AT-N-0603	30MHz~1GHz	17/Oct/2021	16/Oct/2022
RF Cable-R03m	Jye Bao	RG142	CB021	9kHz~30MHz	13/Jun/2022	12/Jun/2023
RF Cable-R03m	Jye Bao	RG142	MY37335/4+CB021-1+CB021-2	30MHz~1GHz	22/Mar/2022	21/Mar/2023
Loop Antenna	TESEQ	HLA 6120	31244	9kHz~30MHz	18/Mar/2022	17/Mar/2023
EMI Test Receiver	R&S	ESR3	102052	9kHz~3.6GHz	13/May/2022	12/May/2023
SENSE-NFC	Sporton	V5.11.0	N/A	N/A	N/A	N/A



Summary

Mode	Result	Type	Freq (Hz)	Level (dBuV)	Limit (dBuV)	Margin (dB)	Condition
Mode 1	Pass	QP	2.211M	38.62	56.00	-17.38	Line

Mode Configure

Mode	Result	Type	Freq (Hz)	Level (dBuV)	Limit (dBuV)	Margin (dB)	Condition	Comments
Mode 1	Pass	QP	157.99k	43.77	65.56	-21.79	Line	-
Mode 1	Pass	AV	157.99k	27.55	55.56	-28.01	Line	-
Mode 1	Pass	QP	187.577k	40.84	64.15	-23.31	Line	-
Mode 1	Pass	AV	187.577k	28.47	54.15	-25.68	Line	-
Mode 1	Pass	QP	220.053k	37.76	62.81	-25.05	Line	-
Mode 1	Pass	AV	220.053k	29.21	52.81	-23.60	Line	-
Mode 1	Pass	QP	506.843k	24.96	56.00	-31.04	Line	-
Mode 1	Pass	AV	506.843k	15.73	46.00	-30.27	Line	-
Mode 1	Pass	QP	2.211M	38.62	56.00	-17.38	Line	-
Mode 1	Pass	AV	2.211M	27.89	46.00	-18.11	Line	-
Mode 1	Pass	QP	11.048M	25.84	60.00	-34.16	Line	-
Mode 1	Pass	AV	11.048M	19.15	50.00	-30.85	Line	-
Mode 1	Pass	QP	169.76k	42.99	64.97	-21.98	Neutral	-
Mode 1	Pass	AV	169.76k	32.53	54.97	-22.44	Neutral	-
Mode 1	Pass	QP	186.085k	43.20	64.20	-21.00	Neutral	-
Mode 1	Pass	AV	186.085k	33.01	54.20	-21.19	Neutral	-
Mode 1	Pass	QP	330.648k	37.83	59.44	-21.61	Neutral	-
Mode 1	Pass	AV	330.648k	29.74	49.44	-19.70	Neutral	-
Mode 1	Pass	QP	720.179k	26.91	56.00	-29.09	Neutral	-
Mode 1	Pass	AV	720.179k	19.30	46.00	-26.70	Neutral	-
Mode 1	Pass	QP	2.247M	32.80	56.00	-23.20	Neutral	-
Mode 1	Pass	AV	2.247M	24.50	46.00	-21.50	Neutral	-
Mode 1	Pass	QP	10.701M	32.16	60.00	-27.84	Neutral	-
Mode 1	Pass	AV	10.701M	24.94	50.00	-25.06	Neutral	-

Conducted Emissions at Powerline_Mode 1

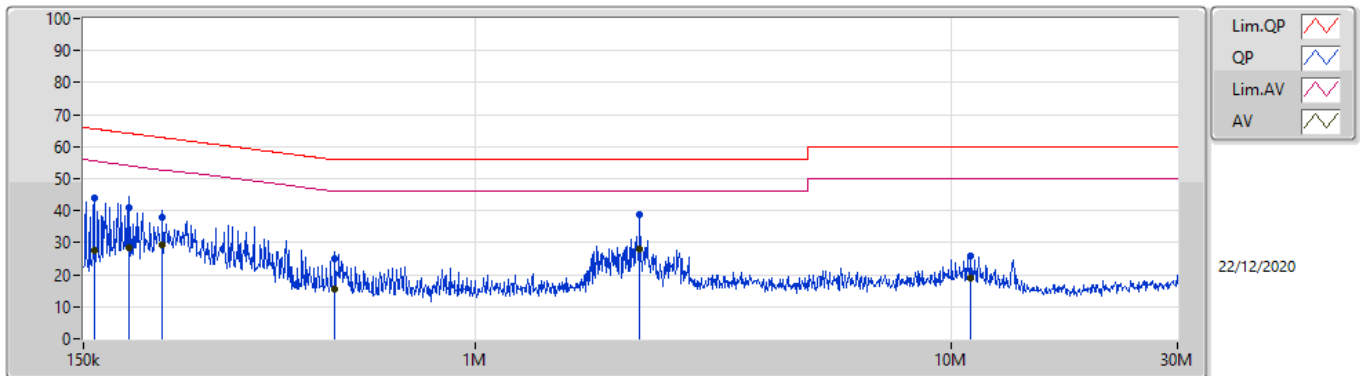

Type	Freq (Hz)	Level (dBuV)	Limit (dBuV)	Margin (dB)	Factor (dB)	Condition	Comment	Raw (dBuV)	LISN (dB)	CL (dB)	AT (dB)
QP	157.99k	43.77	65.56	-21.79	19.60	Line	-	24.17	9.69	0.01	9.90
AV	157.99k	27.55	55.56	-28.01	19.60	Line	-	7.95	9.69	0.01	9.90
QP	187.577k	40.84	64.15	-23.31	19.59	Line	-	21.25	9.68	0.01	9.90
AV	187.577k	28.47	54.15	-25.68	19.59	Line	-	8.88	9.68	0.01	9.90
QP	220.053k	37.76	62.81	-25.05	19.59	Line	-	18.17	9.68	0.01	9.90
AV	220.053k	29.21	52.81	-23.60	19.59	Line	-	9.62	9.68	0.01	9.90
QP	506.843k	24.96	56.00	-31.04	19.57	Line	-	5.39	9.67	0.03	9.87
AV	506.843k	15.73	46.00	-30.27	19.57	Line	-	-3.84	9.67	0.03	9.87
QP	2.211M	38.62	56.00	-17.38	19.58	Line	-	19.04	9.68	0.09	9.81
AV	2.211M	27.89	46.00	-18.11	19.58	Line	-	8.31	9.68	0.09	9.81
QP	11.048M	25.84	60.00	-34.16	19.83	Line	-	6.01	9.71	0.22	9.90
AV	11.048M	19.15	50.00	-30.85	19.83	Line	-	-0.68	9.71	0.22	9.90

Conducted Emissions at Powerline_Mode 1

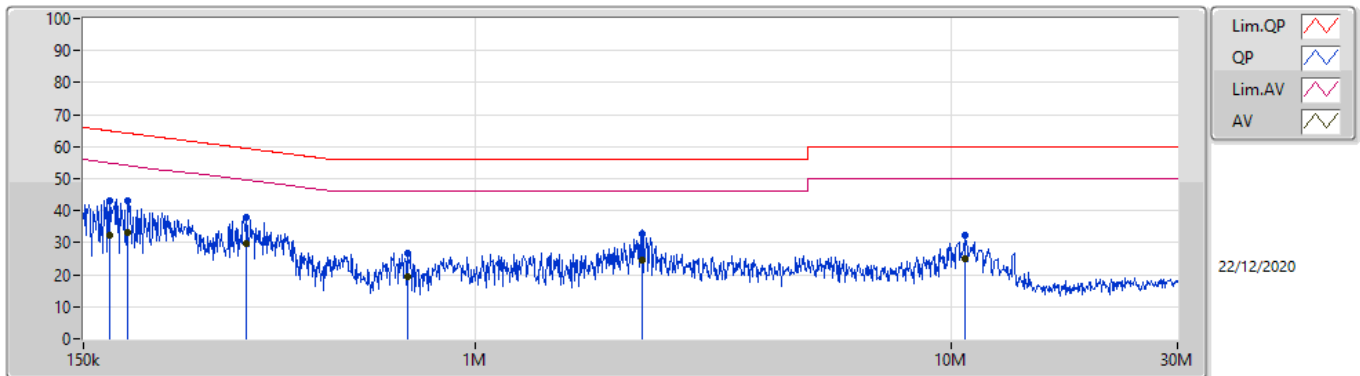

Type	Freq (Hz)	Level (dBuV)	Limit (dBuV)	Margin (dB)	Factor (dB)	Condition	Comment	Raw (dBuV)	LISN (dB)	CL (dB)	AT (dB)
QP	169.76k	42.99	64.97	-21.98	19.60	Neutral	-	23.39	9.69	0.01	9.90
AV	169.76k	32.53	54.97	-22.44	19.60	Neutral	-	12.93	9.69	0.01	9.90
QP	186.085k	43.20	64.20	-21.00	19.59	Neutral	-	23.61	9.68	0.01	9.90
AV	186.085k	33.01	54.20	-21.19	19.59	Neutral	-	13.42	9.68	0.01	9.90
QP	330.648k	37.83	59.44	-21.61	19.59	Neutral	-	18.24	9.67	0.02	9.90
AV	330.648k	29.74	49.44	-19.70	19.59	Neutral	-	10.15	9.67	0.02	9.90
QP	720.179k	26.91	56.00	-29.09	19.55	Neutral	-	7.36	9.67	0.04	9.84
AV	720.179k	19.30	46.00	-26.70	19.55	Neutral	-	-0.25	9.67	0.04	9.84
QP	2.247M	32.80	56.00	-23.20	19.59	Neutral	-	13.21	9.68	0.09	9.82
AV	2.247M	24.50	46.00	-21.50	19.59	Neutral	-	4.91	9.68	0.09	9.82
QP	10.701M	32.16	60.00	-27.84	19.85	Neutral	-	12.31	9.73	0.22	9.90
AV	10.701M	24.94	50.00	-25.06	19.85	Neutral	-	5.09	9.73	0.22	9.90

Summary

Mode	20dB (Hz)	FI-20dB (Hz)	Fh-20dB (Hz)	OBW (Hz)	Limit (Range)
13.553-13.567MHz	-	-	-	-	-
NFC	2.485k	13.55876M	13.56124M	2.256k	13.553-13.567

Result

Mode	Result	20dB (Hz)	FI-20dB (Hz)	Fh-20dB (Hz)	OBW (Hz)	FI-OBW (Hz)	Fh-OBW (Hz)	Limit (Range)
NFC	-	-	-	-	-	-	-	-
13.56MHz_TnomVnom	Pass	2.485k	13.55876M	13.56124M	2.256k	13.55883M	13.56108M	13.553-13.567

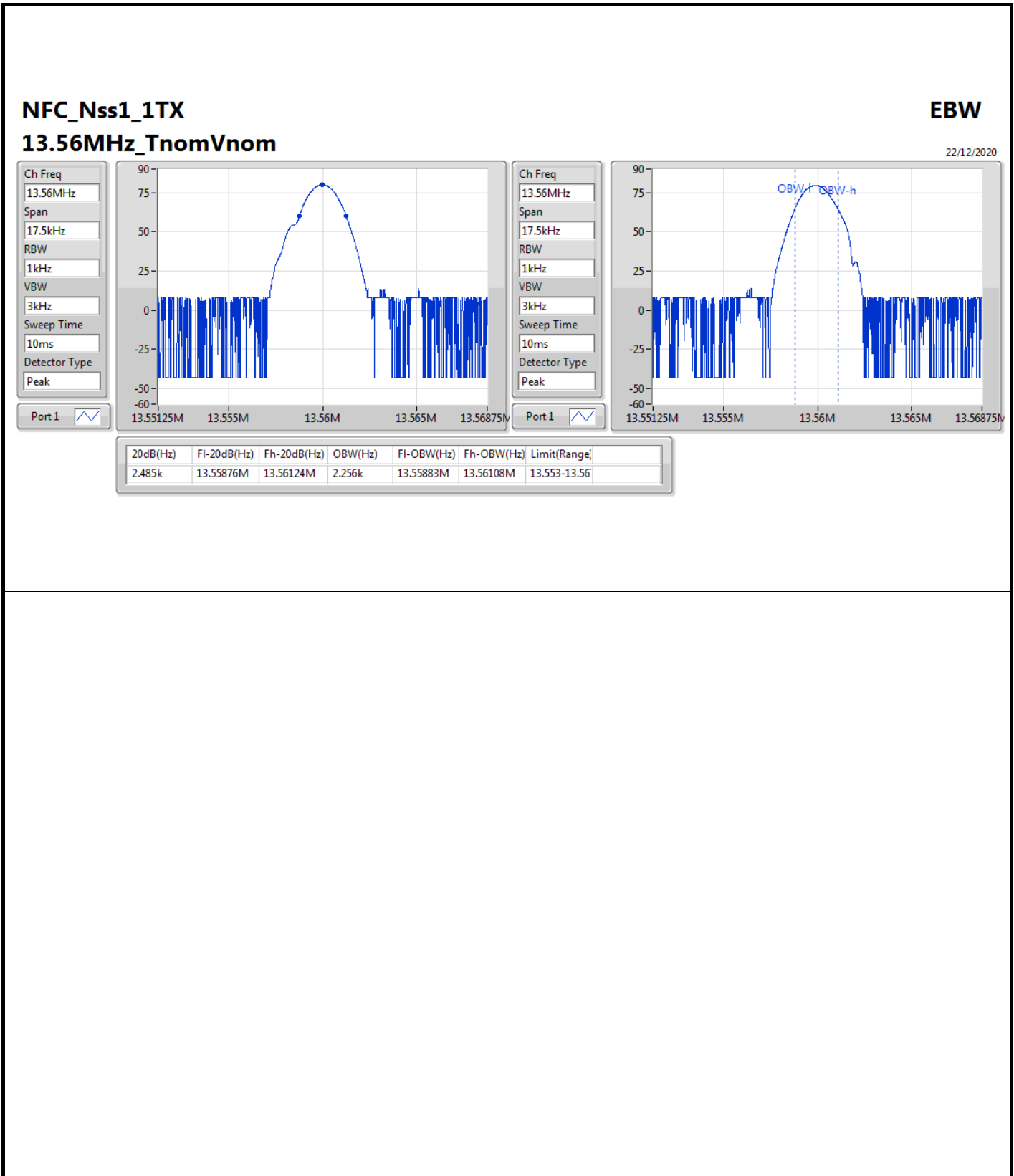



Summary

Mode	Result	Type	Freq (Hz)	Level (dBuV/m)	Limit (dBuV/m)	Margin (dB)	Dist (m)	Azimuth (°)	Height (m)	Comments
13.56M	-	-	-	-	-	-	-	-	-	-
NFC_Nss1_1TX	Pass	PK	747k	40.17	70.15	-29.98	3	0	1.00	-



Result

Mode	Result	Type	Freq (Hz)	Level (dBuV/m)	Limit (dBuV/m)	Margin (dB)	Dist (m)	Azimuth (°)	Height (m)	Comments
NFC_Nss1_1TX	-	-	-	-	-	-	-	-	-	-
13.56MHz_Mode 1	Pass	PK	13.56M	83.40	124.00	-40.60	3	360	1.00	-
13.56MHz_Mode 1	Pass	PK	34.098k	58.21	116.93	-58.72	3	360	1.00	-
13.56MHz_Mode 1	Pass	PK	44.814k	50.55	114.57	-64.02	3	360	1.00	-
13.56MHz_Mode 1	Pass	PK	103.47k	42.64	107.29	-64.65	3	360	1.00	-
13.56MHz_Mode 1	Pass	PK	3.374M	38.83	69.50	-30.67	3	0	1.00	-
13.56MHz_Mode 1	Pass	PK	8.15M	39.25	69.50	-30.25	3	0	1.00	-
13.56MHz_Mode 1	Pass	PK	747k	40.17	70.15	-29.98	3	0	1.00	-

NFC_Nss1_1TX

13.56MHz_Mode 1

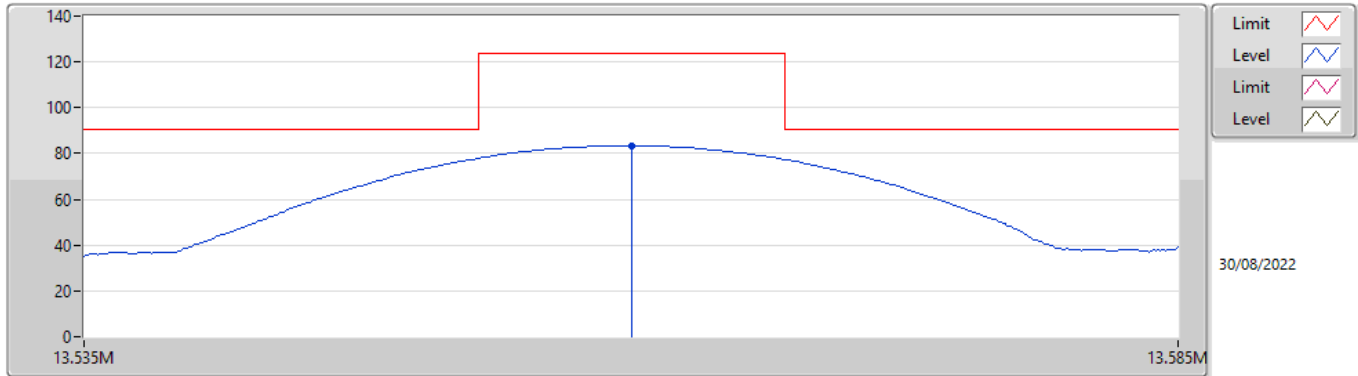

NFC_Nss1_1TX

13.56MHz_Mode 1

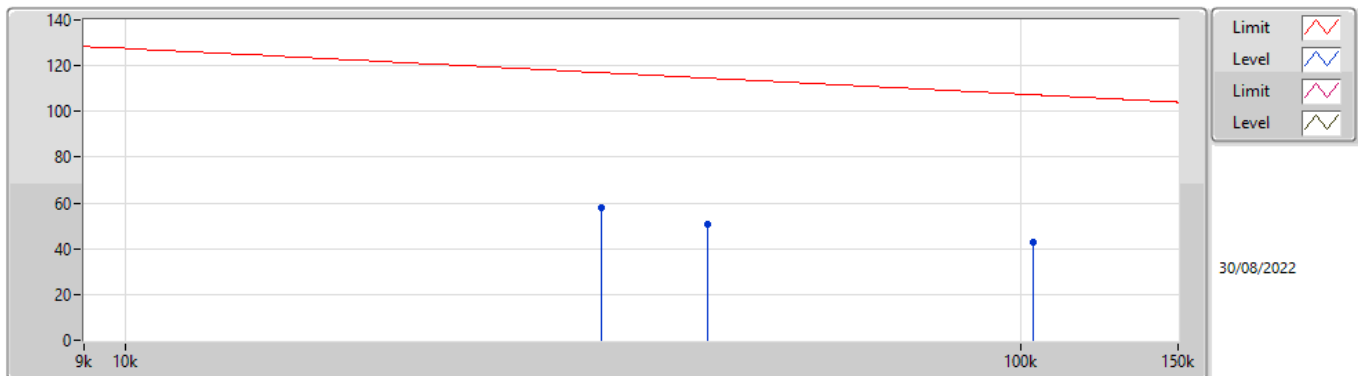

NFC

13.56MHz_Mode 1

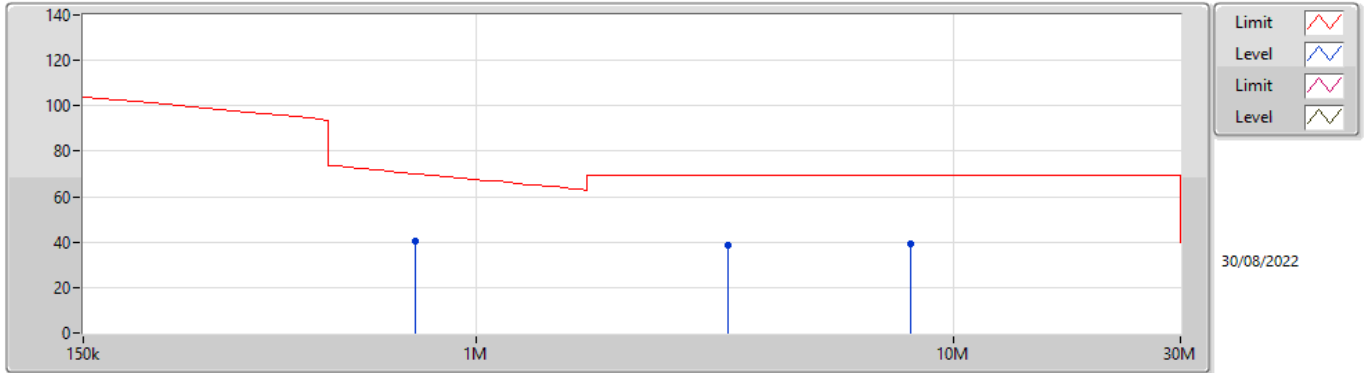

Type	Freq (Hz)	Level (dBuV/m)	Limit (dBuV/m)	Margin (dB)	Factor (dB)	Dist (m)	Condition	Azimuth (°)	Height (m)	Comment	Raw (dBuV)	AF (dB)	CL (dB)	PA (dB)
PK	3.374M	38.83	69.50	-30.67	19.97	3	Horizontal	0	1.00	-	18.86	19.76	0.21	-
PK	8.15M	39.25	69.50	-30.25	21.94	3	Horizontal	0	1.00	-	17.31	21.57	0.37	-
PK	747k	40.17	70.15	-29.98	20.36	3	Horizontal	0	1.00	-	19.81	20.26	0.10	-



Summary

Mode	Result	Type	Freq (Hz)	Level (dBuV/m)	Limit (dBuV/m)	Margin (dB)	Dist (m)	Azimuth (°)	Height (m)	Comments
13.553-13.567MHz	-	-	-	-	-	-	-	-	-	-
NFC	Pass	PK	39.7M	31.61	40.00	-8.39	3	0	1.00	-



Result

Mode	Result	Type	Freq (Hz)	Level (dBuV/m)	Limit (dBuV/m)	Margin (dB)	Dist (m)	Azimuth (°)	Height (m)	Comments
NFC	-	-	-	-	-	-	-	-	-	-
13.56MHz_Mode 1	Pass	PK	39.7M	31.61	40.00	-8.39	3	0	1.00	-
13.56MHz_Mode 1	Pass	PK	59.1M	29.00	40.00	-11.00	3	0	1.00	-
13.56MHz_Mode 1	Pass	PK	94.02M	29.15	43.50	-14.35	3	0	1.00	-
13.56MHz_Mode 1	Pass	PK	307.42M	23.84	46.00	-22.16	3	0	1.00	-
13.56MHz_Mode 1	Pass	PK	365.62M	28.73	46.00	-17.27	3	0	1.00	-
13.56MHz_Mode 1	Pass	PK	416.06M	29.23	46.00	-16.77	3	0	1.00	-
13.56MHz_Mode 1	Pass	PK	94.02M	25.51	43.50	-17.99	3	360	1.00	-
13.56MHz_Mode 1	Pass	PK	227.88M	26.71	46.00	-19.29	3	360	1.00	-
13.56MHz_Mode 1	Pass	PK	307.42M	31.61	46.00	-14.39	3	360	1.00	-
13.56MHz_Mode 1	Pass	PK	336.52M	34.24	46.00	-11.76	3	360	1.00	-
13.56MHz_Mode 1	Pass	PK	365.62M	36.66	46.00	-9.34	3	360	1.00	-
13.56MHz_Mode 1	Pass	PK	416.06M	33.85	46.00	-12.15	3	360	1.00	-

NFC

13.56MHz_Mode 1

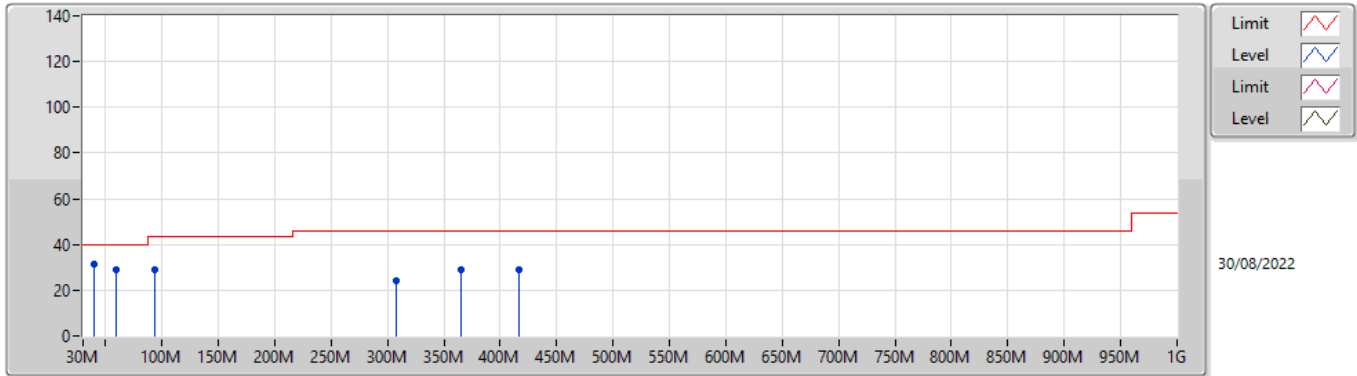

Type	Freq (Hz)	Level (dBuV/m)	Limit (dBuV/m)	Margin (dB)	Factor (dB)	Dist (m)	Condition	Azimuth (°)	Height (m)	Comment	Raw (dBuV)	AF (dB)	CL (dB)	PA (dB)
PK	39.7M	31.61	40.00	-8.39	-8.47	3	Vertical	0	1.00	-	40.08	18.05	1.02	27.54
PK	59.1M	29.00	40.00	-11.00	-14.58	3	Vertical	0	1.00	-	43.58	11.66	1.25	27.49
PK	94.02M	29.15	43.50	-14.35	-10.96	3	Vertical	0	1.00	-	40.11	14.84	1.58	27.38
PK	307.42M	23.84	46.00	-22.16	-5.18	3	Vertical	0	1.00	-	29.02	18.52	2.95	26.65
PK	365.62M	28.73	46.00	-17.27	-3.86	3	Vertical	0	1.00	-	32.59	19.89	3.21	26.96
PK	416.06M	29.23	46.00	-16.77	-2.13	3	Vertical	0	1.00	-	31.36	21.73	3.45	27.31

NFC

13.56MHz_Mode 1

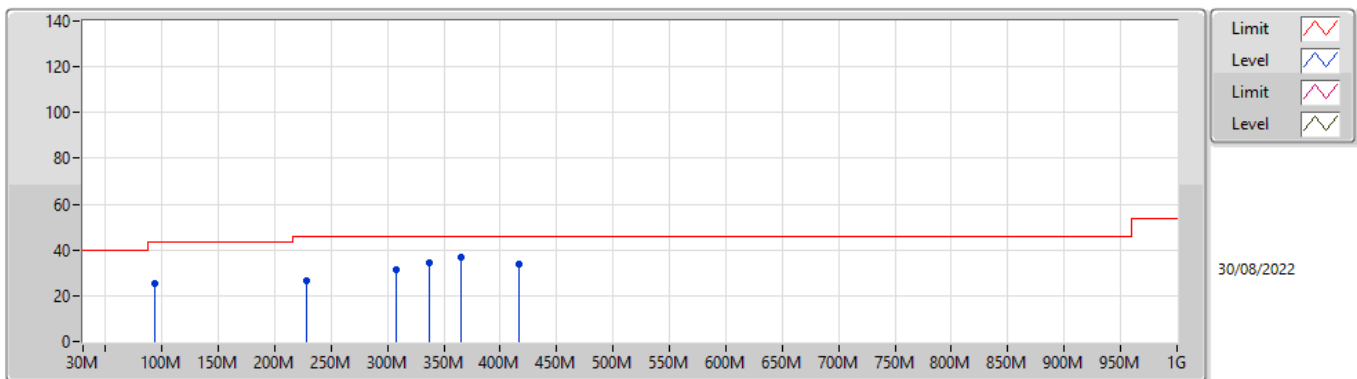

Type	Freq (Hz)	Level (dBuV/m)	Limit (dBuV/m)	Margin (dB)	Factor (dB)	Dist (m)	Condition	Azimuth (°)	Height (m)	Comment	Raw (dBuV)	AF (dB)	CL (dB)	PA (dB)
PK	94.02M	25.51	43.50	-17.99	-10.96	3	Horizontal	360	1.00	-	36.47	14.84	1.58	27.38
PK	227.88M	26.71	46.00	-19.29	-9.33	3	Horizontal	360	1.00	-	36.04	14.93	2.51	26.77
PK	307.42M	31.61	46.00	-14.39	-5.18	3	Horizontal	360	1.00	-	36.79	18.52	2.95	26.65
PK	336.52M	34.24	46.00	-11.76	-4.72	3	Horizontal	360	1.00	-	38.96	18.99	3.08	26.79
PK	365.62M	36.66	46.00	-9.34	-3.86	3	Horizontal	360	1.00	-	40.52	19.89	3.21	26.96
PK	416.06M	33.85	46.00	-12.15	-2.13	3	Horizontal	360	1.00	-	35.98	21.73	3.45	27.31



Summary

Mode	Result	Ch (Hz)	Center (Hz)	ppm	Limit (ppm)	Port	Remark
13.553-13.567MHz	-	-	-	-	-	-	-
NFC	Pass	13.56M	13.559124M	64.5845	100	1	2 min



Result

Mode	Result	Ch (Hz)	Center (Hz)	ppm	Limit (ppm)	Port	Remark
NFC	-	-	-	-	-	-	-
13.56MHz_-20°C	Pass	13.56M	13.559959M	3.0324	100	1	0 min
13.56MHz_-20°C	Pass	13.56M	13.559978M	1.613	100	1	2 min
13.56MHz_-20°C	Pass	13.56M	13.559977M	1.6775	100	1	5 min
13.56MHz_-20°C	Pass	13.56M	13.559969M	2.2582	100	1	10 min
13.56MHz_-10°C	Pass	13.56M	13.55994M	4.4519	100	1	0 min
13.56MHz_-10°C	Pass	13.56M	13.55996M	2.9679	100	1	2 min
13.56MHz_-10°C	Pass	13.56M	13.559602M	29.3566	100	1	5 min
13.56MHz_-10°C	Pass	13.56M	13.559986M	1.0323	100	1	10 min
13.56MHz_0°C	Pass	13.56M	13.559941M	4.3874	100	1	0 min
13.56MHz_0°C	Pass	13.56M	13.560104M	7.6779	100	1	2 min
13.56MHz_0°C	Pass	13.56M	13.559943M	4.1938	100	1	5 min
13.56MHz_0°C	Pass	13.56M	13.559944M	4.1293	100	1	10 min
13.56MHz_10°C	Pass	13.56M	13.559948M	3.8067	100	1	0 min
13.56MHz_10°C	Pass	13.56M	13.560136M	10.0651	100	1	2 min
13.56MHz_10°C	Pass	13.56M	13.559945M	4.0648	100	1	5 min
13.56MHz_10°C	Pass	13.56M	13.559989M	0.8388	100	1	10 min
13.56MHz_20°C	Pass	13.56M	13.559959M	3.0324	100	1	0 min
13.56MHz_20°C	Pass	13.56M	13.559124M	64.5845	100	1	2 min
13.56MHz_20°C	Pass	13.56M	13.559971M	2.1292	100	1	5 min
13.56MHz_20°C	Pass	13.56M	13.559944M	4.1293	100	1	10 min
13.56MHz_30°C	Pass	13.56M	13.559783M	16.001	100	1	0 min
13.56MHz_30°C	Pass	13.56M	13.559966M	2.5163	100	1	2 min
13.56MHz_30°C	Pass	13.56M	13.559964M	2.6453	100	1	5 min
13.56MHz_30°C	Pass	13.56M	13.559955M	3.2905	100	1	10 min
13.56MHz_40°C	Pass	13.56M	13.560005M	0.3871	100	1	0 min
13.56MHz_40°C	Pass	13.56M	13.559941M	4.3874	100	1	2 min
13.56MHz_40°C	Pass	13.56M	13.559942M	4.2583	100	1	5 min
13.56MHz_40°C	Pass	13.56M	13.560397M	29.2921	100	1	10 min
13.56MHz_50°C	Pass	13.56M	13.55994M	4.4519	100	1	0 min
13.56MHz_50°C	Pass	13.56M	13.559941M	4.3228	100	1	2 min
13.56MHz_50°C	Pass	13.56M	13.559934M	4.839	100	1	5 min
13.56MHz_50°C	Pass	13.56M	13.559947M	3.9357	100	1	10 min
13.56MHz_20°C-138V	Pass	13.56M	13.559949M	3.7422	100	1	0 min
13.56MHz_20°C-138V	Pass	13.56M	13.559957M	3.1615	100	1	2 min
13.56MHz_20°C-138V	Pass	13.56M	13.559955M	3.2905	100	1	5 min
13.56MHz_20°C-138V	Pass	13.56M	13.559952M	3.5486	100	1	10 min
13.56MHz_20°C-120V	Pass	13.56M	13.559957M	3.1615	100	1	0 min
13.56MHz_20°C-120V	Pass	13.56M	13.560066M	4.9035	100	1	2 min
13.56MHz_20°C-120V	Pass	13.56M	13.560507M	37.4216	100	1	5 min
13.56MHz_20°C-120V	Pass	13.56M	13.559967M	2.4518	100	1	10 min
13.56MHz_20°C-102V	Pass	13.56M	13.559955M	3.355	100	1	0 min
13.56MHz_20°C-102V	Pass	13.56M	13.559955M	3.355	100	1	2 min
13.56MHz_20°C-102V	Pass	13.56M	13.559955M	3.355	100	1	5 min



Frequency Stability

Appendix D

Mode	Result	Ch (Hz)	Center (Hz)	ppm	Limit (ppm)	Port	Remark
13.56MHz_20°C-102V	Pass	13.56M	13.559955M	3.2905	100	1	10 min