



CERTIFICATION TEST REPORT

Report Number. : 12720909-E1V3

Applicant : VeriFone, Inc.
1400 WEST STANFORD RANCH ROAD
ROCKLIN, CA, 95765, U.S.A.

Model : M440

FCC ID : B32M440

IC : 787C-M440

EUT Description : Point-of-Interaction Terminal

Test Standard(s) : FCC 47 CFR PART 15 SUBPART C
ISED RSS-247 ISSUE 2
ISED RSS-GEN ISSUE 5

Date of Issue:
August 06, 2019

Prepared by:
UL Verification Services Inc.
47173 Benicia Street
Fremont, CA 94538 U.S.A.
TEL: (510) 319-4000
FAX: (510) 661-0888



NVLAP Lab code: 200065-0

REPORT REVISION HISTORY

<u>Rev.</u>	<u>Issue Date</u>	<u>Revisions</u>	<u>Revised By</u>
V1	7/9/2019	Initial Issue	--
V2	7/22/2019	Updated customer name to VeriFone, Inc.	Tri Pham
V3	8/6/2019	Updated XYZ statement	Tri Pham

TABLE OF CONTENTS

1. ATTESTATION OF TEST RESULTS	5
2. TEST METHODOLOGY	6
3. FACILITIES AND ACCREDITATION	6
4. CALIBRATION AND UNCERTAINTY	7
4.1. MEASURING INSTRUMENT CALIBRATION	7
4.2. SAMPLE CALCULATION	7
4.3. MEASUREMENT UNCERTAINTY	7
5. EQUIPMENT UNDER TEST	8
5.1. EUT DESCRIPTION	8
5.2. MAXIMUM OUTPUT POWER.....	8
5.3. DESCRIPTION OF AVAILABLE ANTENNAS	8
5.4. SOFTWARE AND FIRMWARE.....	8
5.5. WORST-CASE CONFIGURATION AND MODE.....	9
5.6. DESCRIPTION OF TEST SETUP.....	10
6. TEST AND MEASUREMENT EQUIPMENT	13
7. MEASUREMENT METHODS	14
8. ANTENNA PORT TEST RESULTS	15
8.1. ON TIME AND DUTY CYCLE.....	15
8.2. 20 dB AND 99% BANDWIDTH	17
8.2.1. BLUETOOTH BASIC DATA RATE GFSK MODULATION	18
8.2.2. BLUETOOTH ENHANCED DATA RATE 8PSK MODULATION.....	19
8.3. HOPPING FREQUENCY SEPARATION.....	20
8.3.1. BLUETOOTH BASIC DATA RATE GFSK MODULATION	21
8.3.2. BLUETOOTH ENHANCED DATA RATE 8PSK MODULATION.....	22
8.4. NUMBER OF HOPPING CHANNELS.....	23
8.4.1. BLUETOOTH BASIC DATA RATE GFSK MODULATION	24
8.4.2. BLUETOOTH ENHANCED DATA RATE 8PSK MODULATION.....	26
8.5. AVERAGE TIME OF OCCUPANCY.....	28
8.5.1. BLUETOOTH BASIC DATA RATE GFSK MODULATION	29
8.5.2. BLUETOOTH ENHANCED DATA RATE 8PSK MODULATION.....	31
8.6. OUTPUT POWER.....	33
8.6.1. BLUETOOTH BASIC DATA RATE GFSK MODULATION	34
8.6.2. BLUETOOTH ENHANCED DATA RATE DQPSK MODULATION	34
8.6.3. BLUETOOTH ENHANCED DATA RATE 8PSK MODULATION.....	34
8.7. AVERAGE POWER.....	35

8.7.1.	BLUETOOTH BASIC DATA RATE GFSK MODULATION	36
8.7.2.	BLUETOOTH ENHANCED DATA RATE DQPSK MODULATION	36
8.7.3.	BLUETOOTH ENHANCED DATA RATE 8PSK MODULATION.....	36
8.8.	<i>CONDUCTED SPURIOUS EMISSIONS</i>	37
8.8.1.	BLUETOOTH BASIC DATA RATE GFSK MODULATION	38
8.8.2.	BLUETOOTH ENHANCED DATA RATE 8PSK MODULATION.....	40
9.	RADIATED TEST RESULTS	42
9.1.	<i>TRANSMITTER ABOVE 1 GHz</i>	44
9.1.1.	BLUETOOTH BASIC DATA RATE GFSK MODULATION	44
9.1.2.	BLUETOOTH ENHANCED DATA RATE 8PSK MODULATION.....	54
9.2.	<i>WORST CASE BELOW 30MHZ</i>	64
9.3.	<i>WORST CASE BELOW 1 GHZ</i>	66
9.4.	<i>WORST CASE 18-26 GHZ</i>	68
10.	AC POWER LINE CONDUCTED EMISSIONS	70
10.1.1.	AC Power Line Norm.....	71
11.	SETUP PHOTOS	73

1. ATTESTATION OF TEST RESULTS

COMPANY NAME: VeriFone, Inc.
1400 WEST STANFORD RANCH ROAD
ROCKLIN, CA, 95765, U.S.A.

EUT DESCRIPTION: Point-of-Interaction (POI) terminal

MODEL: M440

SERIAL NUMBER: 346522674 (Radiated), 346522625 (Conducted)

DATE TESTED: May 26, 2019 to June 10, 2019

APPLICABLE STANDARDS	
STANDARD	TEST RESULTS
CFR 47 Part 15 Subpart C	Complies
ISED RSS-247 Issue 2	Complies
ISED RSS-GEN Issue 5	Complies

UL Verification Services Inc. tested the above equipment in accordance with the requirements set forth in the above standards. The test results show that the equipment tested is capable of demonstrating compliance with the requirements as documented in this report.

The results documented in this report apply only to the tested sample, under the conditions and modes of operation as described herein. It is the manufacturer's responsibility to assure that additional production units of this model are manufactured with identical electrical and mechanical components. All samples tested were in good operating condition throughout the entire test program. Measurement Uncertainties are published for informational purposes only and were not taken into account unless noted otherwise.

This document may not be altered or revised in any way unless done so by UL Verification Services Inc. and all revisions are duly noted in the revisions section. Any alteration of this document not carried out by UL Verification Services Inc. will constitute fraud and shall nullify the document. This report must not be used by the client to claim product certification, approval, or endorsement by NVLAP, NIST, any agency of the Federal Government, or any agency of the U.S. government.

Approved & Released For
UL Verification Services Inc. By:



Frank Ibrahim
Operations Leader
Consumer Technology Division
UL Verification Services Inc.

Reviewed By:



Tri Pham
Project Engineer
Consumer Technology Division
UL Verification Services Inc.

2. TEST METHODOLOGY

The tests documented in this report were performed in accordance with FCC CFR 47 Part 2, FCC CFR 47 Part 15, ANSI C63.10-2013, KDB 558074 D01 15.247 Meas Guidance v05r02, RSS-GEN Issue 5, and RSS-247 Issue 2.

3. FACILITIES AND ACCREDITATION

The test sites and measurement facilities used to collect data are located at 47173 and 47266 Benicia Street, and 47658 Kato Road, Fremont, California, USA. Line conducted emissions are measured only at the 47173 address. The following table identifies which facilities were utilized for radiated emission measurements documented in this report. Specific facilities are also identified in the test results sections.

47173 Benicia Street	47266 Benicia Street	47658 Kato Road
<input type="checkbox"/> Chamber A	<input type="checkbox"/> Chamber D	<input checked="" type="checkbox"/> Chamber I
<input type="checkbox"/> Chamber B	<input type="checkbox"/> Chamber E	<input type="checkbox"/> Chamber J
<input type="checkbox"/> Chamber C	<input type="checkbox"/> Chamber F	<input checked="" type="checkbox"/> Chamber K
	<input type="checkbox"/> Chamber G	<input type="checkbox"/> Chamber L
	<input type="checkbox"/> Chamber H	<input type="checkbox"/> Chamber M

The above test sites and facilities are covered under FCC Test Firm Registration # 208313. Chambers above are covered under Industry Canada company address and respective code

UL Verification Services Inc. is accredited by NVLAP, Laboratory Code 200065-0

4. CALIBRATION AND UNCERTAINTY

4.1. MEASURING INSTRUMENT CALIBRATION

The measuring equipment utilized to perform the tests documented in this report has been calibrated in accordance with the manufacturer's recommendations and is traceable to recognized national standards.

4.2. SAMPLE CALCULATION

RADIATED EMISSIONS

Where relevant, the following sample calculation is provided:

$$\text{Field Strength (dBuV/m)} = \text{Measured Voltage (dBuV)} + \text{Antenna Factor (dB/m)} + \text{Cable Loss (dB)} - \text{Preamp Gain (dB)}$$
$$36.5 \text{ dBuV} + 18.7 \text{ dB/m} + 0.6 \text{ dB} - 26.9 \text{ dB} = 28.9 \text{ dBuV/m}$$

MAINS CONDUCTED EMISSIONS

Where relevant, the following sample calculation is provided:

$$\text{Final Voltage (dBuV)} = \text{Measured Voltage (dBuV)} + \text{Cable Loss (dB)} + \text{Limiter Factor (dB)} + \text{LISN Insertion Loss.}$$
$$36.5 \text{ dBuV} + 0 \text{ dB} + 10.1 \text{ dB} + 0 \text{ dB} = 46.6 \text{ dBuV}$$

4.3. MEASUREMENT UNCERTAINTY

Where relevant, the following measurement uncertainty levels have been estimated for tests performed on the apparatus:

PARAMETER	UNCERTAINTY
Worst Case Conducted Disturbance, 9KHz to 0.15 MHz	3.84 dB
Worst Case Conducted Disturbance, 0.15 to 30 MHz	3.65 dB
Worst Case Radiated Disturbance, 9KHz to 30 MHz	2.52 dB
Worst Case Radiated Disturbance, 30 to 1000 MHz	4.88 dB
Worst Case Radiated Disturbance, 1000 to 18000 MHz	4.24 dB
Worst Case Radiated Disturbance, 18000 to 26000 MHz	4.37 dB
Worst Case Radiated Disturbance, 26000 to 40000 MHz	5.17 dB

Uncertainty figures are valid to a confidence level of 95%.

5. EQUIPMENT UNDER TEST

5.1. EUT DESCRIPTION

The M440 is an integrated countertop Point-of-Interaction (POI) terminal designed to process online and offline transactions in an attended environment. The Multi-Lane (M440) product is part of the two-chip Carbon family (Android applications and Engage payment engine). It accepts all payment methods - MSR, PSCR, Contactless, and wallets. The radio communication mechanisms available in the system include WiFi dual band 802.11 a/b/g/n and Bluetooth 4.1 BLE (BT4.2 on Android 7.1 or later versions), and CTLS (NFC).

5.2. MAXIMUM OUTPUT POWER

The transmitter has a maximum peak conducted output power as follows:

Frequency Range (MHz)	Mode	Output Power (dBm)	Output Power (mW)
2402 - 2480	Basic GFSK	12.85	19.28
2402 - 2480	Enhanced DQPSK	12.66	18.45
2402 - 2480	Enhanced 8PSK	13.18	20.80

Note: GFSK, DQPSK, 8PSK average Power are all investigated, The GFSK & 8PSK Power are the worst case. Testing is based on these modes to showing compliance. For average power data please refer to section 8.7.

5.3. DESCRIPTION OF AVAILABLE ANTENNAS

The radio utilizes a dual band stamped metal antenna., with a maximum gain of 2.47 dBi.

5.4. SOFTWARE AND FIRMWARE

The test utility software used during testing was Qualcomm Radio Control Tool, Version 4.0.00123.

5.5. WORST-CASE CONFIGURATION AND MODE

Radiated bandedge, harmonics, and spurious emissions from 1 GHz to 18GHz were performed with EUT set to transmit at the Low/Middle/High channels.

Radiated emission below 1GHz, above 18GHz, and power line conducted emission were performed with the EUT set to transmit at the channel with highest output power as worst-case scenario.

The fundamental of the EUT was investigated in two orthogonal orientations X and Z, it was determined that X-axis was the worst case orientation, therefore all final radiated testing was performed with the EUT in X(flatbed) position.

Worst-case data rates as provided by the client were:

GFSK mode: DH5
8PSK mode: 3-DH5

BT and Wifi bands do not transmit simultaneously.

5.6. DESCRIPTION OF TEST SETUP

SUPPORT EQUIPMENT

Support Equipment List				
Description	Manufacturer	Model	Serial Number	FCC ID/ DoC
Laptop AC/DC Adapter	Dell	LA65NM130	CN-0JNKWD-72438-61M-0728-A03	DoC
Laptop	Dell	Latitude E7450	H24JN72	DoC
AC/DC Adapter	Verifone	2AAJ012F US	A1914000013	DoC
Base Plug	Verifone	M400 BAS	445-101-01-A REV:A00	DoC
Debug Board	Verifone	LBL445-003-01-A	445-113-01-A	DoC

I/O CABLES (CONDUCTED TEST)

I/O Cable List						
Cable No	Port	# of identical	Connector Type	Cable Type	Cable Length (m)	Remarks
1	AC	1	AC	Unshielded	0.9	AC Mains to AC/DC Adapter
2	DC	1	DC	Unshielded	1.85	AC/DC Adapter to Laptop
3	USB	1	USB Type-C to Type-A	Shielded	1	Laptop to Debug Board
4	USB	1	USB Type-C	Shielded	1.5	Base Plug to EUT
5	DC	5	DC	Unshielded	1.8	AC/DC Adapter to Base Plug
6	Antenna	1	SMA	Unshielded	0.08	To spectrum analyzer

I/O CABLES (AC POWER CONDUCTED TEST AND RADIATED TEST)

I/O Cable List						
Cable No	Port	# of identical	Connector Type	Cable Type	Cable Length (m)	Remarks
1	AC	1	AC	Unshielded	0.9	AC Mains to AC/DC Adapter
2	DC	1	DC	Unshielded	1.85	AC/DC Adapter to Laptop
3	USB	1	USB Type-C to Type-A	Shielded	1	Laptop to Debug Board
4	USB	1	USB Type-C	Shielded	1.5	Base Plug to EUT
5	DC	5	DC	Unshielded	1.8	AC/DC Adapter to Base Plug

TEST SETUP-CONDUCTED TEST

The EUT was connected to a Base Plug and powered by the Base Plug. Test software exercised the EUT.

SETUP DIAGRAM

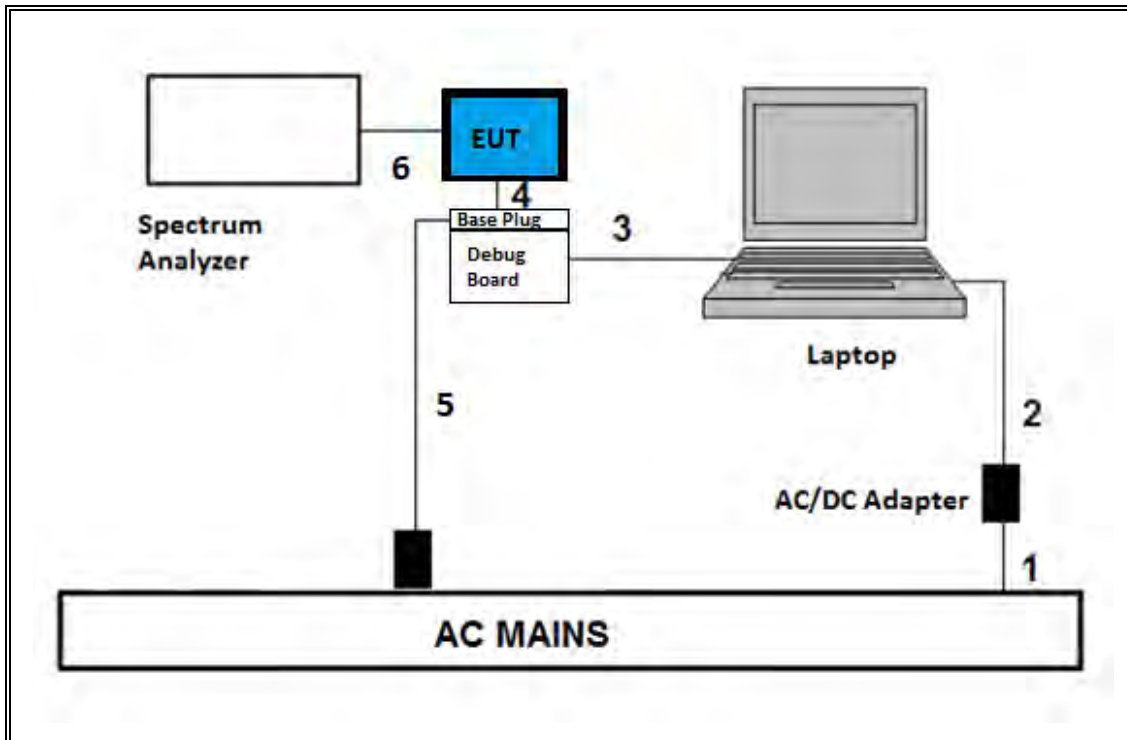

TEST SETUP- AC LINE CONDUCTED TEST AND RADIATED TEST

The EUT was connected to a Base Plug and powered by the Base Plug. Test software exercised the EUT.

SETUP DIAGRAM

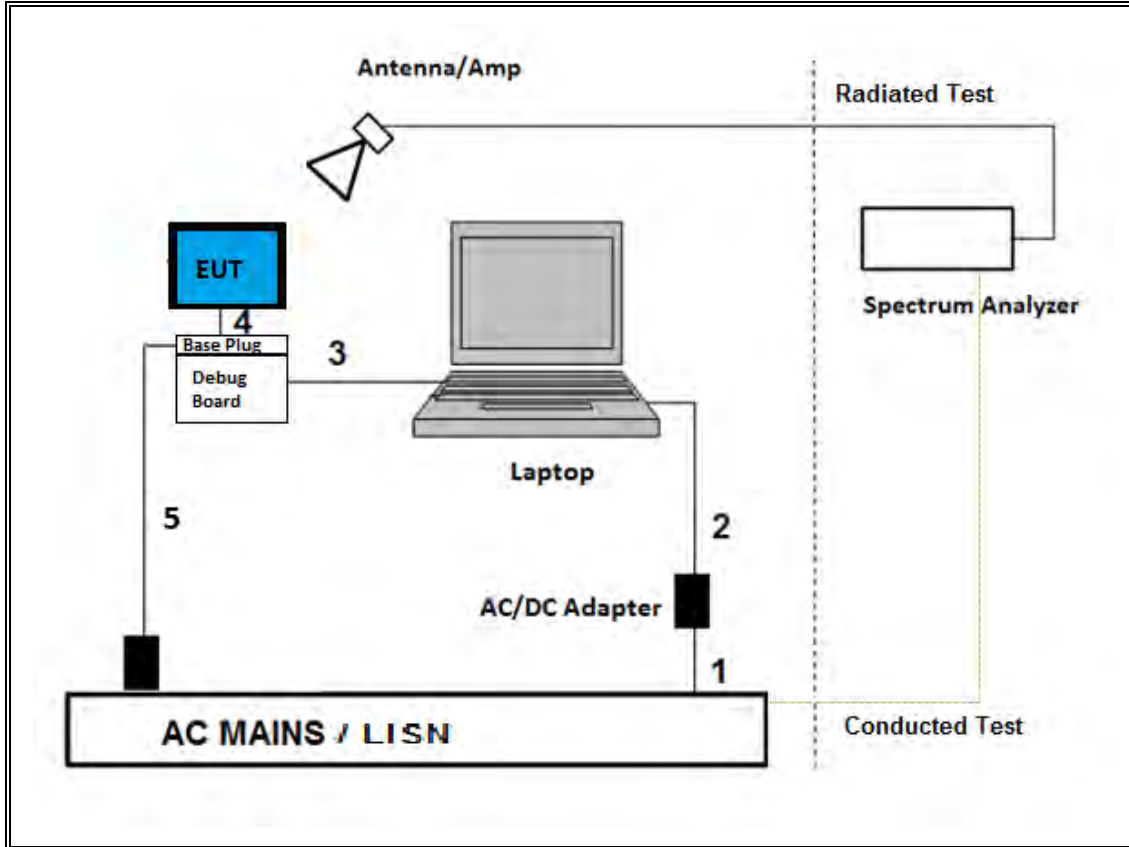

6. TEST AND MEASUREMENT EQUIPMENT

The following test and measurement equipment were utilized for the tests documented in this report:

TEST EQUIPMENT LIST					
Description	Manufacturer	Model	ID Num	Cal Due	Last Cal
6 port rf switch, 1-18GHz	Pasternack	PE7159	171455	08/01/2019	08/01/2018
Power Meter, P-series single channel	Agilent (Keysight) Technologies	N1911A	T1271	07/26/2019	07/26/2018
Power Sensor, P-series, 50MHz to 18GHz, Wideband	Agilent (Keysight) Technologies	N1921A	T1224	10/09/2019	10/09/2018
Antenna, Passive Loop 30Hz – 1MHz	Electro-Metrics	EM-6871	PRE0179465	05/31/2020	05/31/2019
Antenna, Passive Loop 100kHz – 30MHz	Electro-Metrics	EM-6872	PRE0179467	05/31/2020	05/31/2019
Antenna, Horn 700MHz-18GHz	AH Systems Inc.	SAS-571	PRE0190810	07/10/2019	07/10/2017
EMI TEST RECEIVER	Rohde & Schwarz	ESW44	PRE0179377	02/15/2020	02/15/2019
EMI TEST RECEIVER	Rohde & Schwarz	ESW44	PRE0179376	02/14/2020	02/14/2019
Spectrum Analyzer, PXA, 3Hz to 44GHz	Agilent (Keysight) Technologies	N9030A	T1450	01/24/2020	01/24/2019
Amplifier, 1-18GHz	MITIQ	AFS42-00101800-25-S-42	PRE0181078	08/01/2019	08/01/2018
Amplifier, 9kHz to 1GHz, 32 dB	Sonoma Instrument	310	PRE0186650	12/13/2019	12/13/2018
Hybrid Antenna, 30MHz to 3GHz	SunAR rf motion	JB3	PRE0184052	10/24/2019	10/24/2018
Antenna, Horn 18 to 26.5GHz	ARA	MWH-1826/B	PRE0182188	08/29/2019	08/29/2018
Pre-Amp, 18-26.5GHz	AMPLICAL	AMP18G26.5-60	PRE0181238	05/01/2020	05/01/2019
AC Line Conducted					
EMI Receiver	Rohde & Schwarz	ESR	T1436	02/14/2020	02/14/2019
LISN for Conducted Emissions CISPR-16	FCC INC.	FCC LISN 50/250	T1310	06/15/2019	06/15/2018
Test Software List					
Radiated Software	UL	UL EMC		Ver 9.5, June 22, 2018	
Antenna Port Software	UL	UL RF		Ver 9.6, April 18, 2019	
AC Line Conducted Software	UL	UL EMC		Ver 9.5, May 26, 2015	

* Testing performed before calibration due date.

7. MEASUREMENT METHODS

On Time and Duty Cycle: ANSI C63.10-2013 Section 11.6

Occupied BW (20dB): ANSI C63.10-2013 Section 6.9.2

Occupied BW (99%): ANSI C63.10-2013 Section 6.9.3

Carrier Frequency Separation: ANSI C63.10-2013 Section 7.8.2

Number of Hopping Frequencies: ANSI C63.10-2013 Section 7.8.3

Time of Occupancy (Dwell Time): ANSI C63.10-2013 Section 7.8.4

Peak Output Power: ANSI C63.10-2013 Section 7.8.5

Conducted Spurious Emissions: ANSI C63.10-2013 Section 7.8.8

Conducted Band-Edge: ANSI C63.10-2013 Section 6.10.4

Radiated Spurious Emissions Below 30MHz: ANSI C63.10-2013 Section 6.4

Radiated Spurious Emissions 30-1000MHz: ANSI C63.10-2013 Section 6.3 and 6.5

Radiated Spurious Emissions above 1GHz: ANSI C63.10-2013 Section 6.3 and 6.6

Radiated Band-edge: ANSI C63.10-2013 Section 6.10.5

AC Power-line conducted emissions: ANSI C63.10-2013, Section 6.2.

8. ANTENNA PORT TEST RESULTS

8.1. ON TIME AND DUTY CYCLE

LIMITS

None; for reporting purposes only.

PROCEDURE

ANSI C63.10, Section 11.6 : Zero-Span Spectrum Analyzer Method.

ON TIME AND DUTY CYCLE RESULTS

Mode	ON Time B (msec)	Period (msec)	Duty Cycle x (linear)	Duty Cycle (%)	Duty Cycle Correction Factor (dB)	1/T Minimum VBW (kHz)
Bluetooth GFSK	2.89	3.75	0.771	77.1%	1.13	0.346
Bluetooth 8PSK	2.89	3.75	0.771	77.1%	1.13	0.346

DUTY CYCLE PLOTS

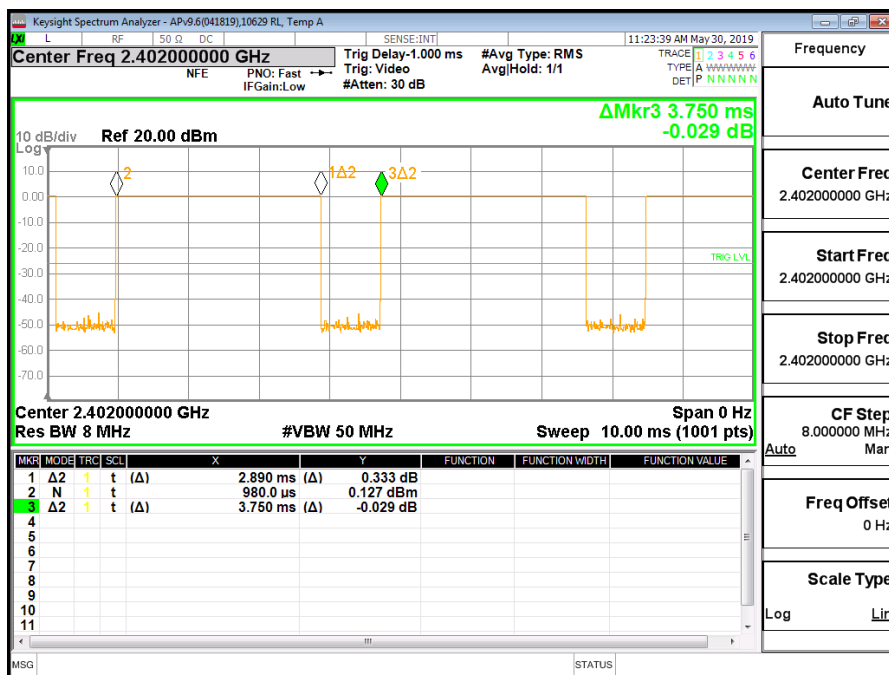

BLUETOOTH GFSK



BLUETOOTH 8PSK

8.2. 20 dB AND 99% BANDWIDTH

LIMITS

None; for reporting purposes only.

TEST PROCEDURE

The transmitter output is connected to a spectrum analyzer. The RBW is set to $\geq 1\%$ of the 20 dB bandwidth. The VBW is set to \geq RBW. The sweep time is coupled.

RESULTS

8.2.1. BLUETOOTH BASIC DATA RATE GFSK MODULATION

Channel	Frequency (MHz)	20dB Bandwidth (MHz)	99% Bandwidth (MHz)
Low	2402	0.931	0.877
Mid	2441	0.933	0.878
High	2480	0.930	0.875

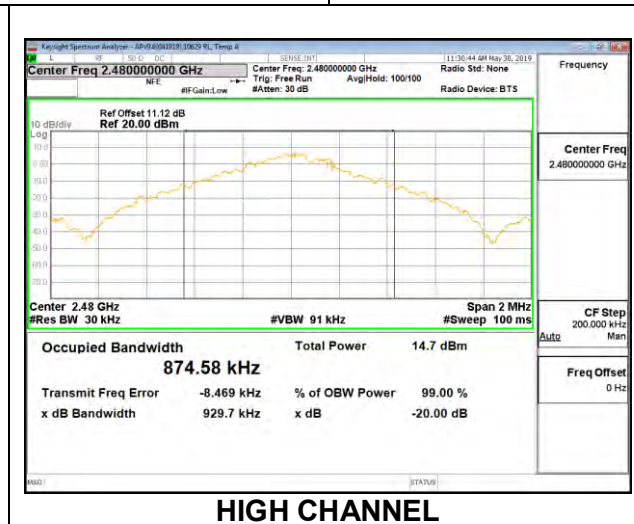
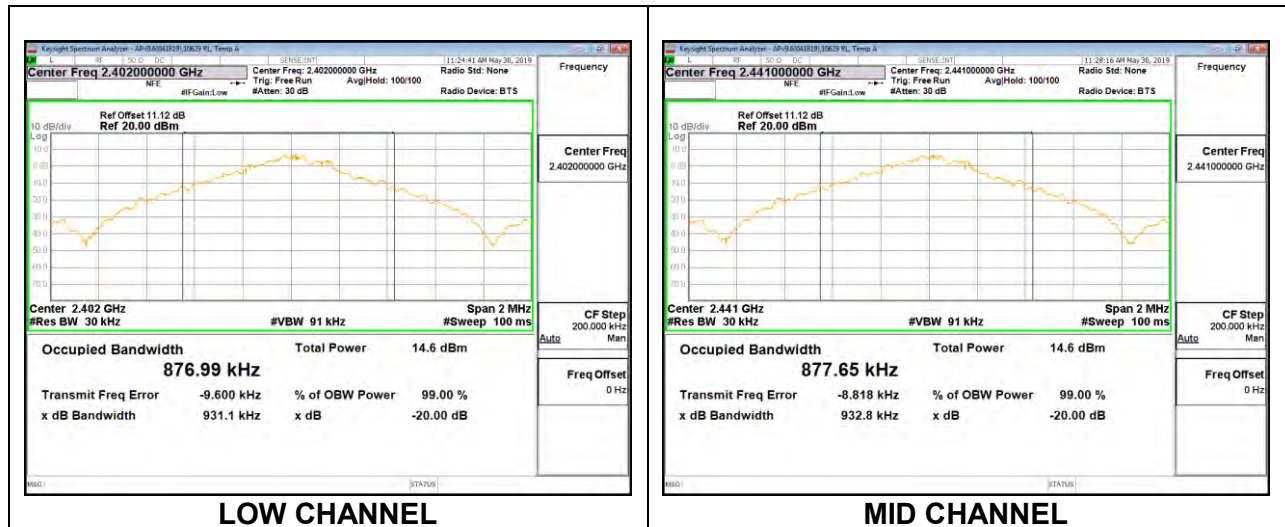

8.2.2. BLUETOOTH ENHANCED DATA RATE 8PSK MODULATION

Channel	Frequency (MHz)	20dB Bandwidth (MHz)	99% Bandwidth (MHz)
Low	2402	1.262	1.179
Mid	2441	1.264	1.179
High	2480	1.262	1.177

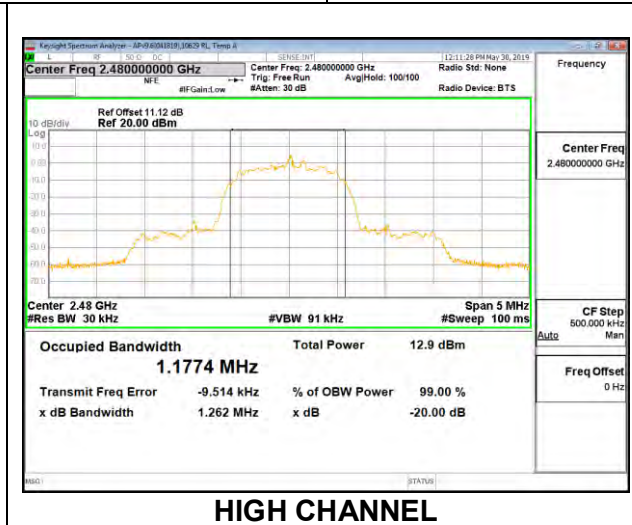
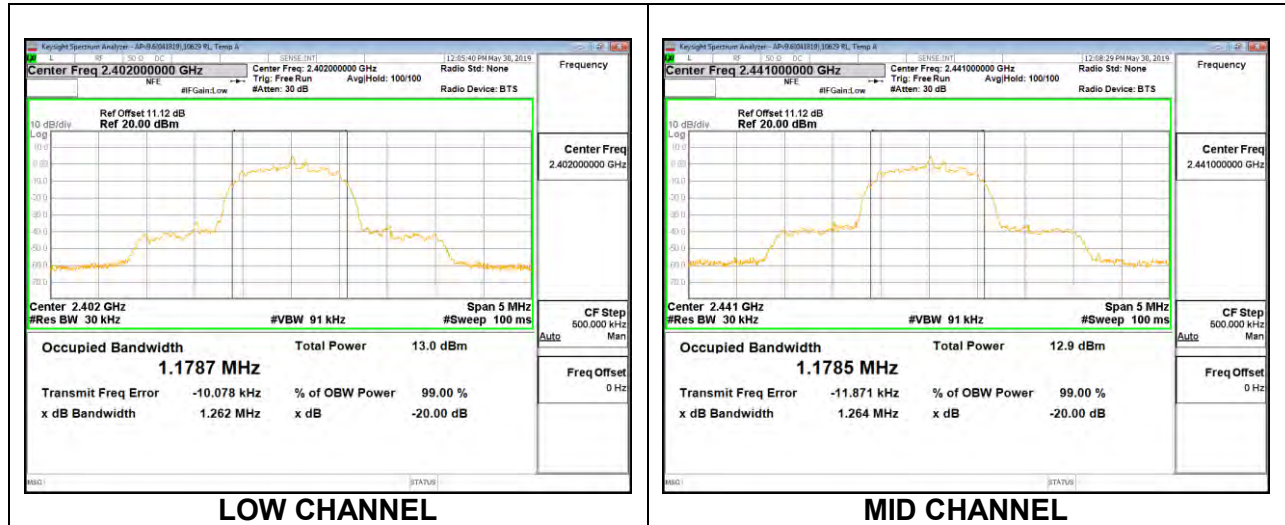

8.3. HOPPING FREQUENCY SEPARATION

LIMITS

FCC §15.247 (a) (1)

RSS-247 (5.1) (b)

Frequency hopping systems shall have hopping channel carrier frequencies separated by a minimum of 25 kHz or the 20 dB bandwidth of the hopping channel, whichever is greater.

Alternatively, frequency hopping systems operating in the 2400-2483.5 MHz band may have hopping channel carrier frequencies that are separated by 25 kHz or two-thirds of the 20 dB bandwidth of the hopping channel, whichever is greater, provided the systems operate with an output power no greater than 125 mW.

TEST PROCEDURE

The transmitter output is connected to a spectrum analyzer. The RBW is set to 300 kHz and the VBW is set to $VBW \geq RBW$. The sweep time is coupled.

RESULTS

8.3.1. BLUETOOTH BASIC DATA RATE GFSK MODULATION

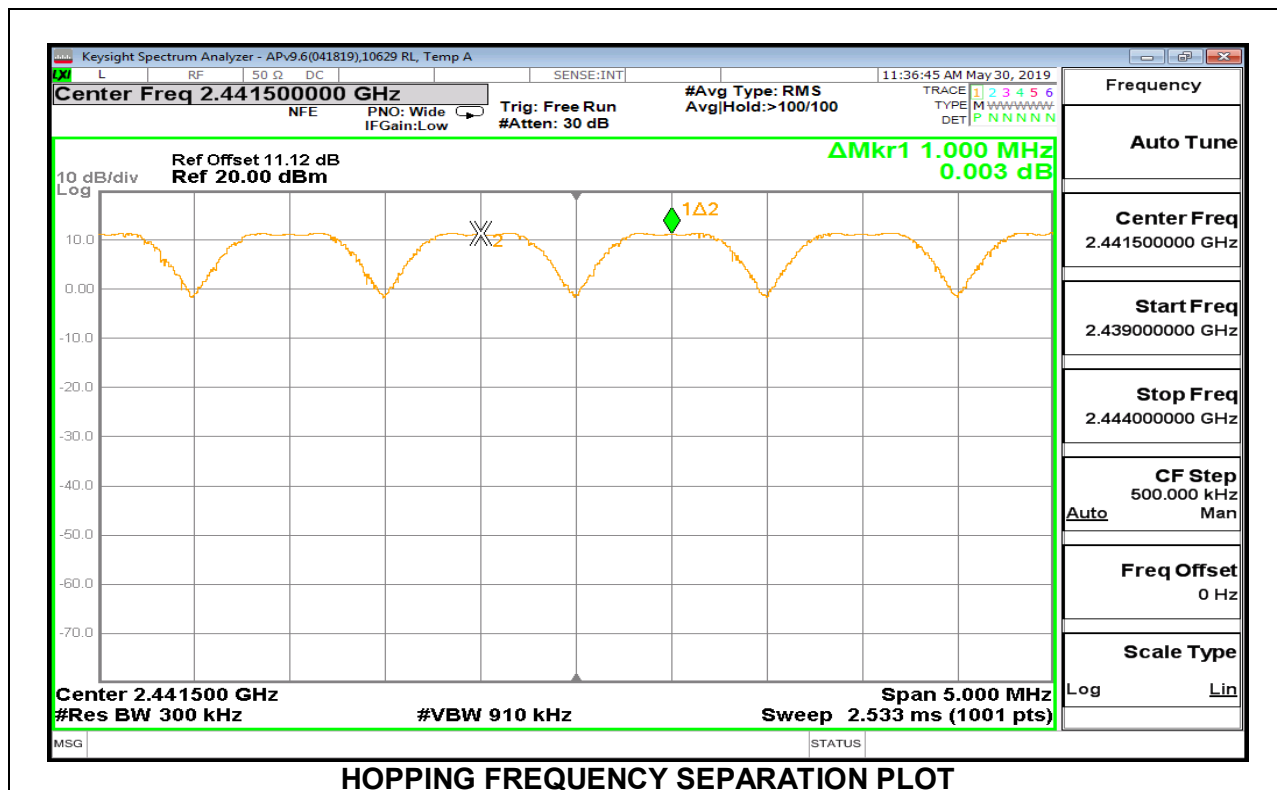

8.3.2. BLUETOOTH ENHANCED DATA RATE 8PSK MODULATION

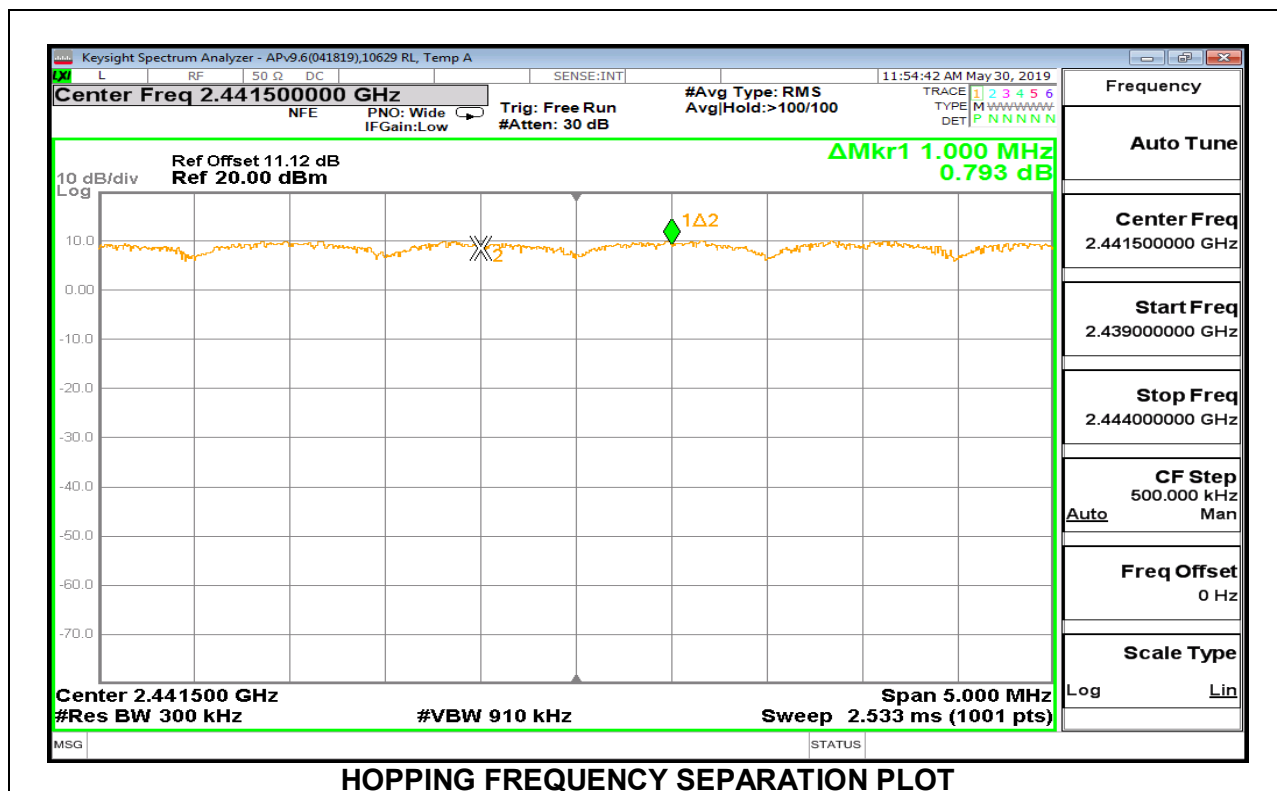

8.4. NUMBER OF HOPPING CHANNELS

LIMITS

FCC §15.247 (a) (1) (iii)

RSS-247 (5.1) (d)

Frequency hopping systems in the 2400 – 2483.5 MHz band shall use at least 15 non-overlapping channels.

TEST PROCEDURE

The transmitter output is connected to a spectrum analyzer. The span is set to cover the entire authorized band, in either a single sweep or in multiple contiguous sweeps. The RBW is set to a maximum of 1 % of the span. The analyzer is set to Max Hold.

RESULTS

Normal Mode: 79 Channels Observed

8.4.1. BLUETOOTH BASIC DATA RATE GFSK MODULATION

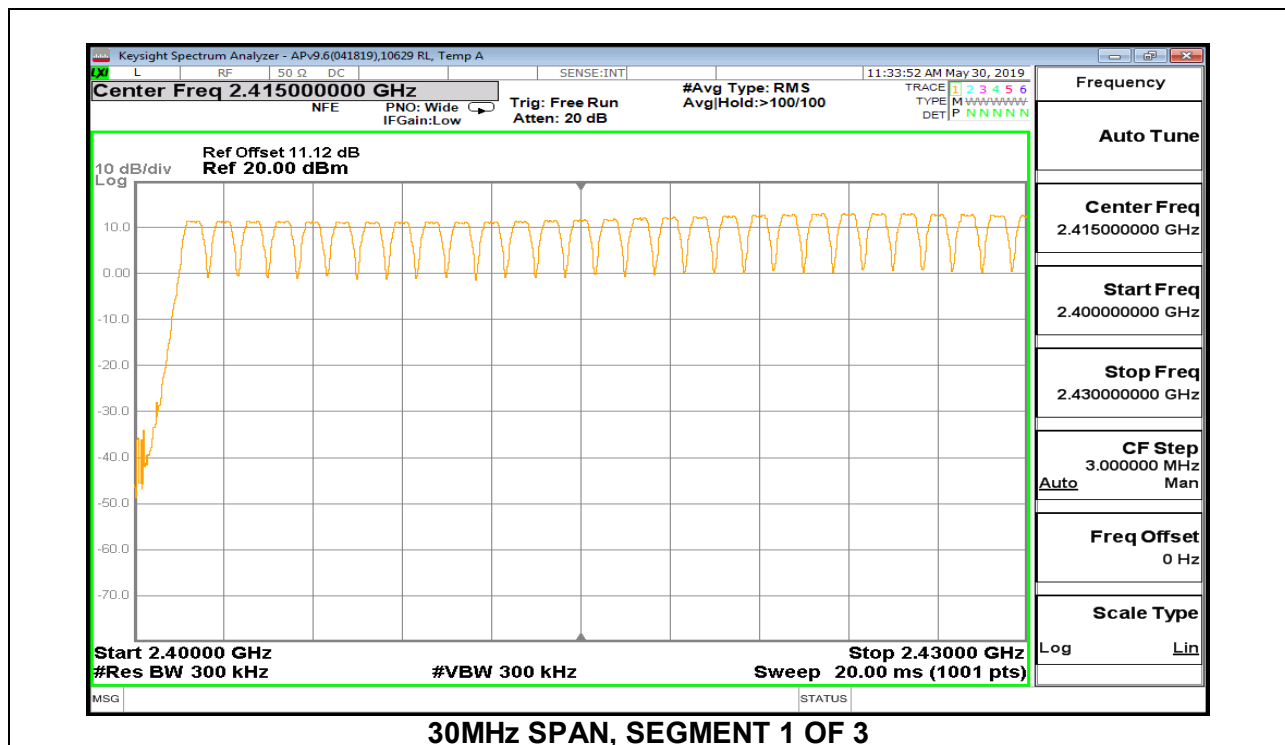
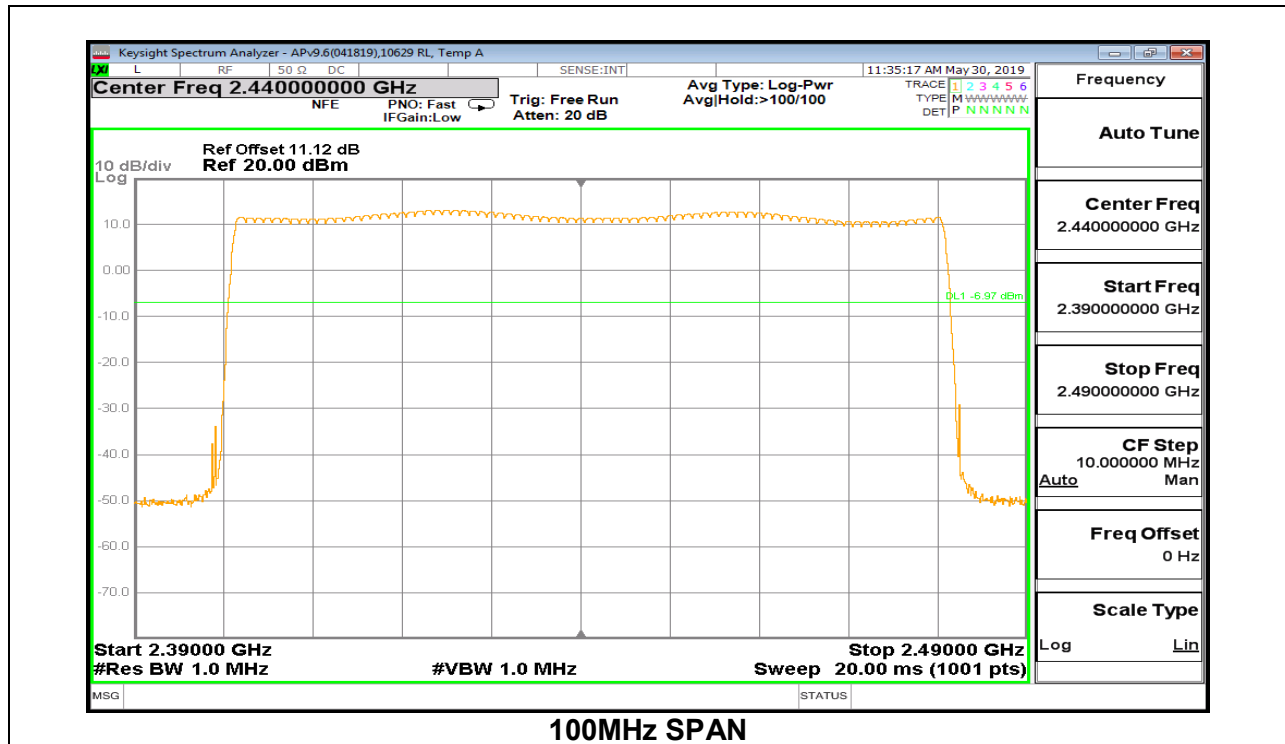

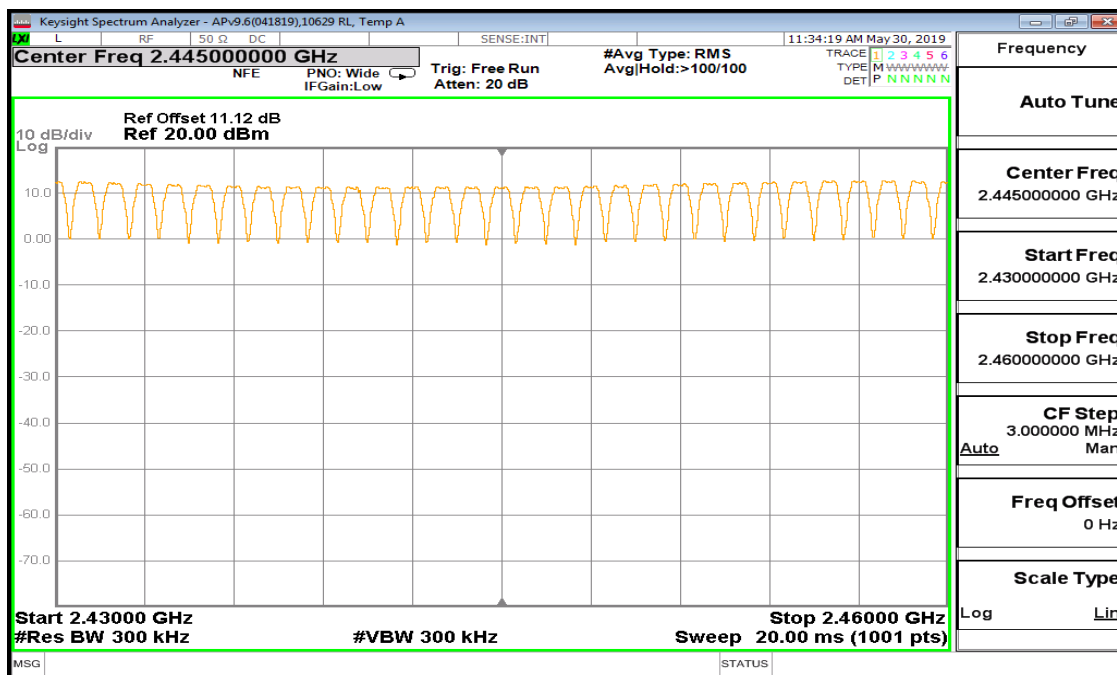

30MHz SPAN, SEGMENT 2 OF 3

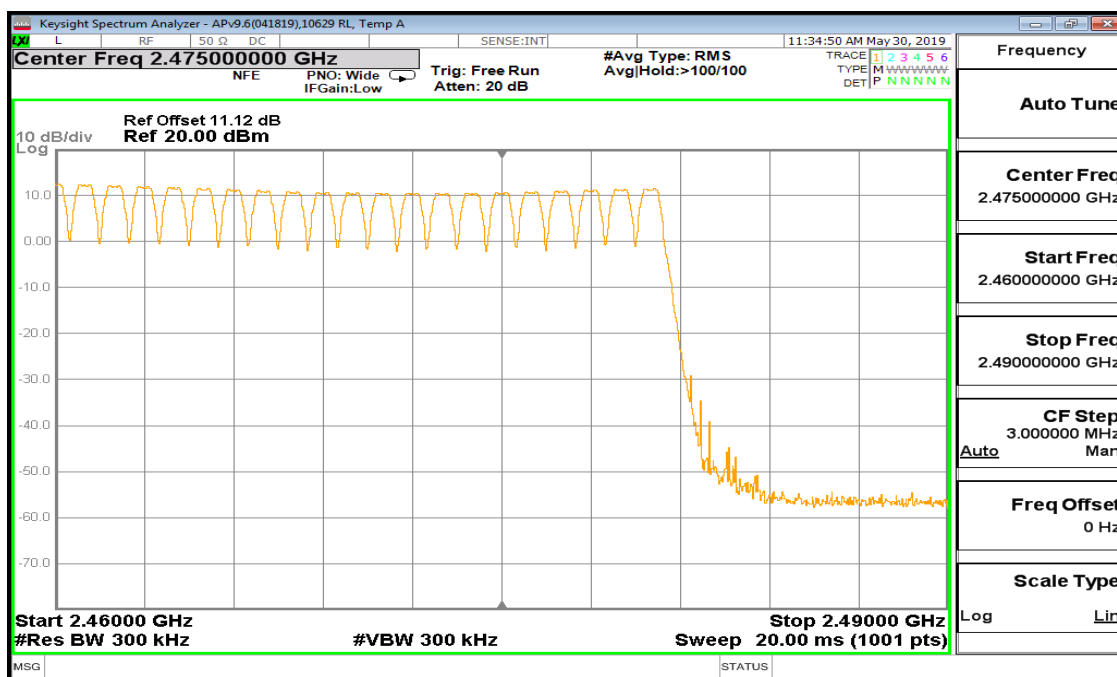

30MHz SPAN, SEGMENT 3 OF 3

8.4.2. BLUETOOTH ENHANCED DATA RATE 8PSK MODULATION

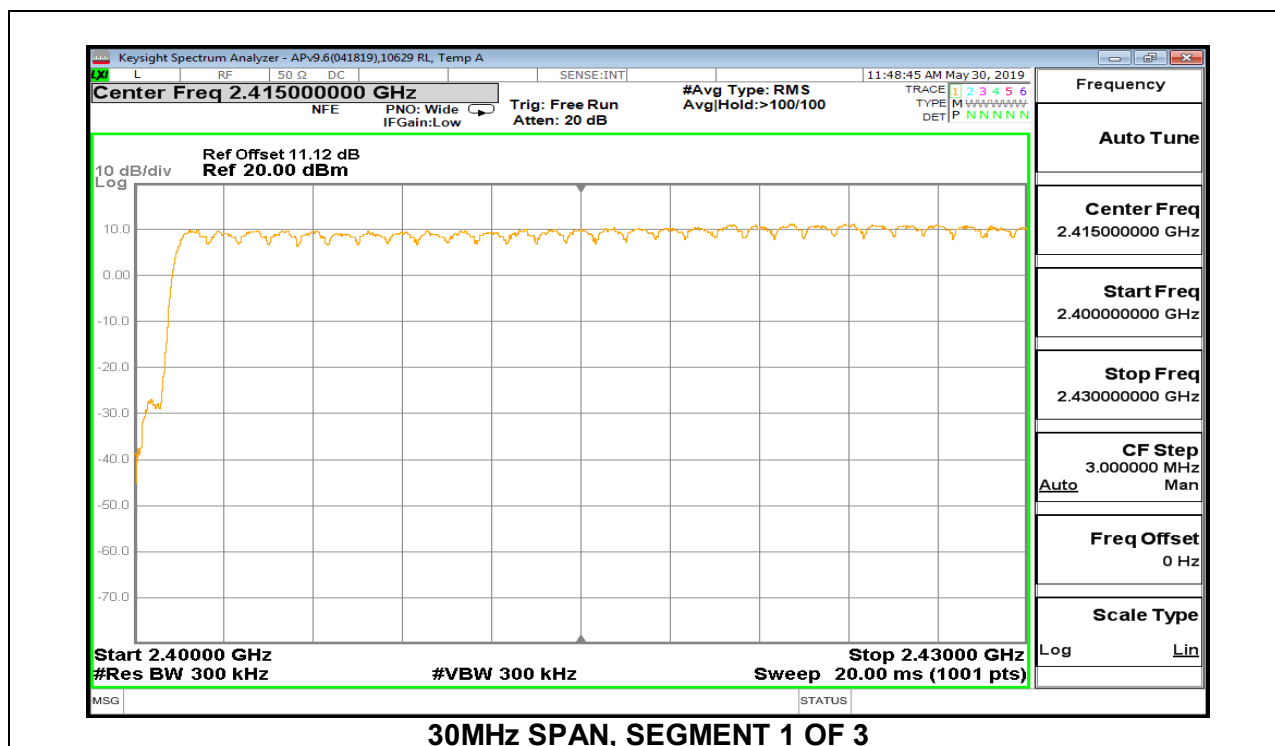
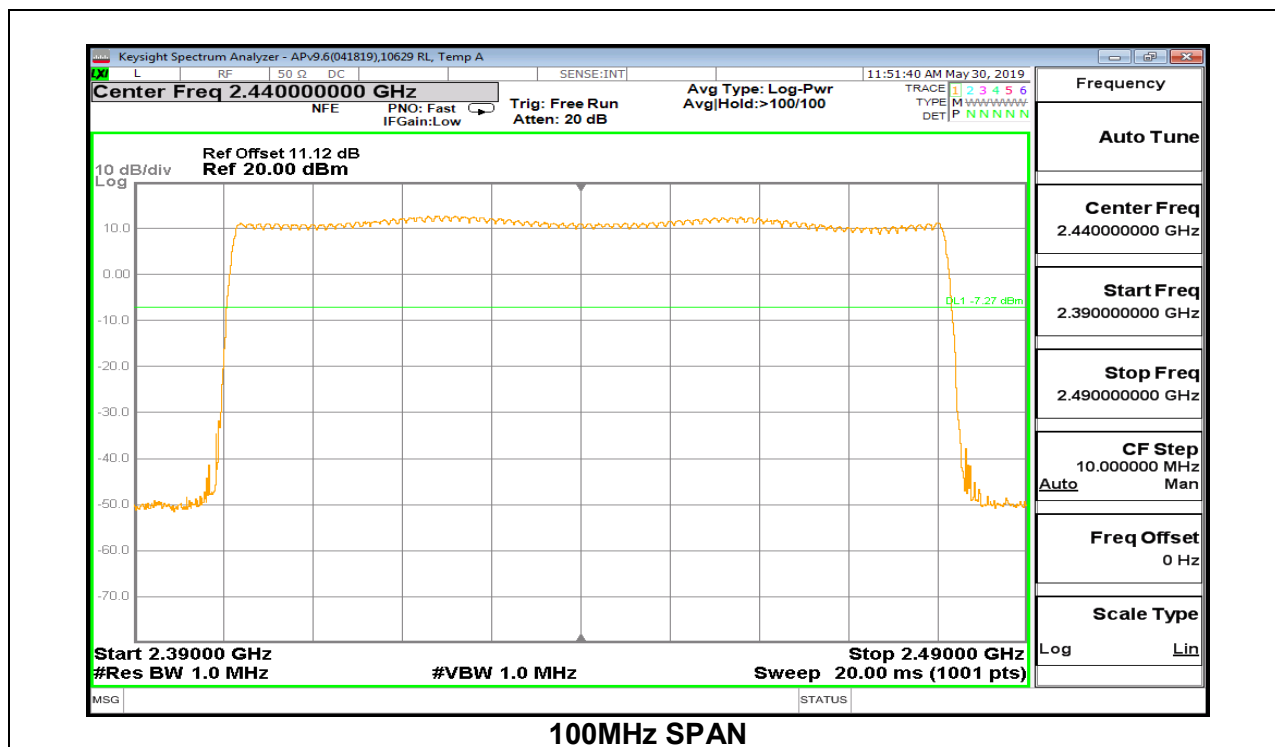

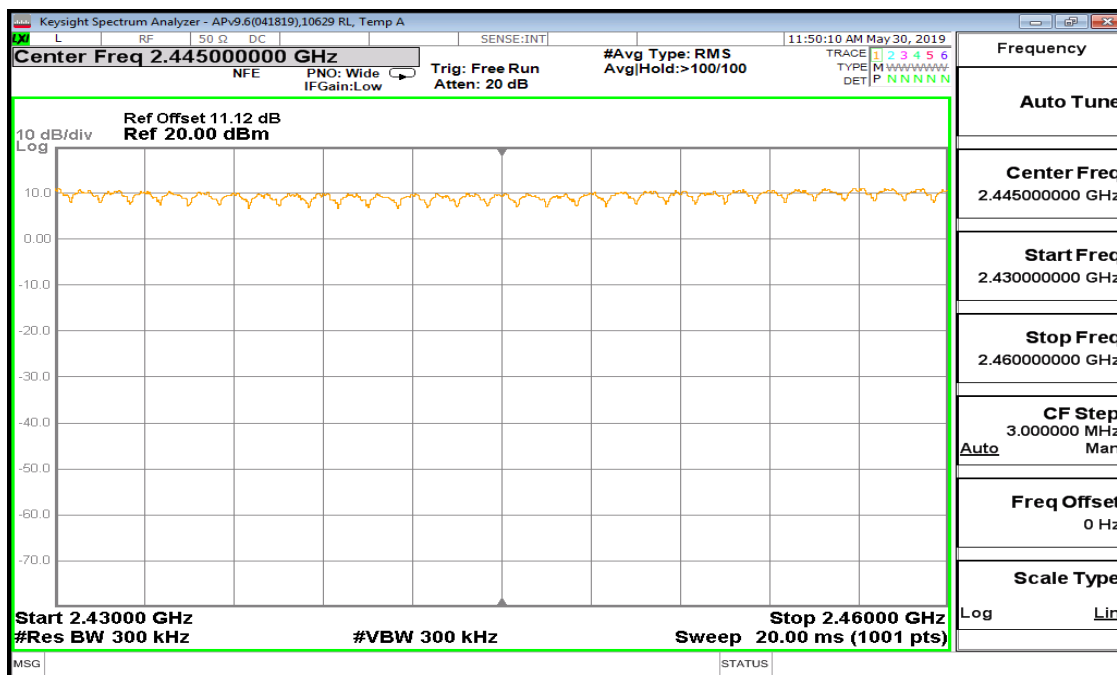

30MHz SPAN, SEGMENT 2 OF 3

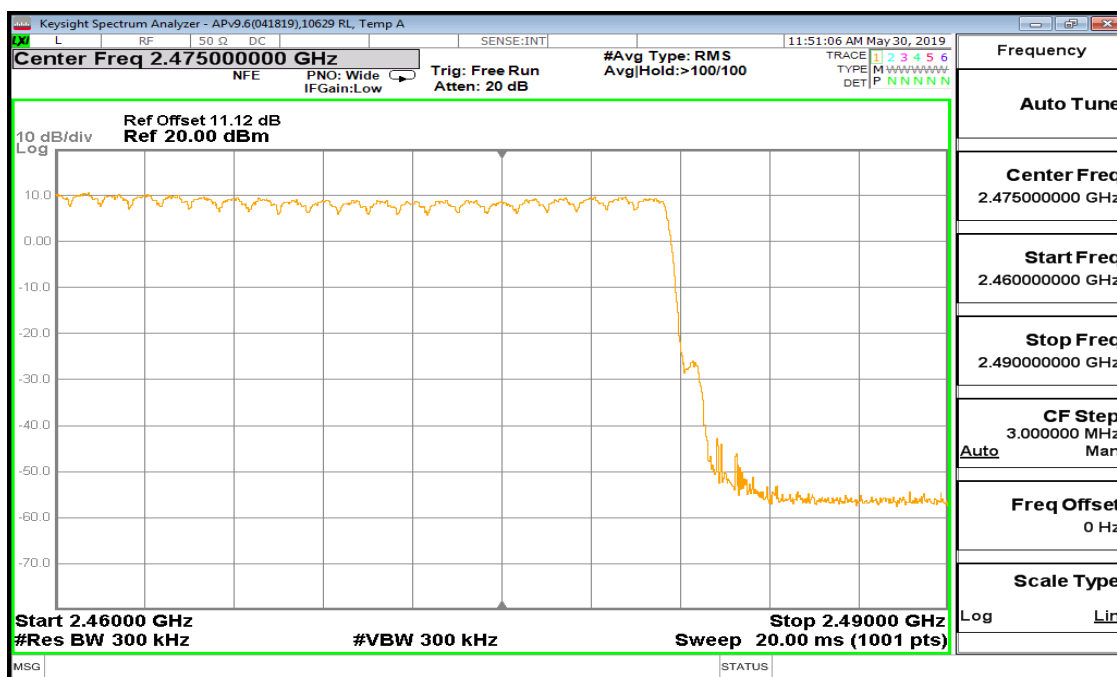

30MHz SPAN, SEGMENT 3 OF 3

8.5. AVERAGE TIME OF OCCUPANCY

LIMITS

FCC §15.247 (a) (1) (iii)

RSS-247 (5.1) (d)

The average time of occupancy on any channel shall not be greater than 0.4 seconds within a period of 0.4 seconds multiplied by the number of hopping channels employed.

TEST PROCEDURE

The transmitter output is connected to a spectrum analyzer. The span is set to 0 Hz, centered on a single, selected hopping channel. The width of a single pulse is measured in a fast scan. The number of pulses is measured in a 3.16 second scan, to enable resolution of each occurrence.

The average time of occupancy in the specified 3.16 second period (79 channels * 0.4 s) is equal to $10 * (\# \text{ of pulses in } 3.16 \text{ s}) * \text{ pulse width}$.

For AFH mode, the average time of occupancy in the specified 8 second period (20 channels * 0.4 seconds) is equal to $10 * (\# \text{ of pulses in } 0.8 \text{ s}) * \text{ pulse width}$.

RESULTS

8.5.1. BLUETOOTH BASIC DATA RATE GFSK MODULATION

DH Packet	Pulse Width (msec)	Number of Pulses in 3.16 seconds	Average Time of Occupancy (sec)	Limit (sec)	Margin (sec)
GFSK Normal Mode					
DH1	0.38	30	0.1140	0.4	-0.2860
DH3	1.64	16	0.2618	0.4	-0.1382
DH5	2.88	11	0.3172	0.4	-0.0828
DH Packet	Pulse Width (sec)	Number of Pulses in 0.8 seconds	Average Time of Occupancy (sec)	Limit (sec)	Margin (sec)
GFSK AFH Mode					
DH1	0.38	7.5	0.02850	0.4	-0.3715
DH3	1.636	4	0.06544	0.4	-0.3346
DH5	2.884	2.75	0.07931	0.4	-0.3207

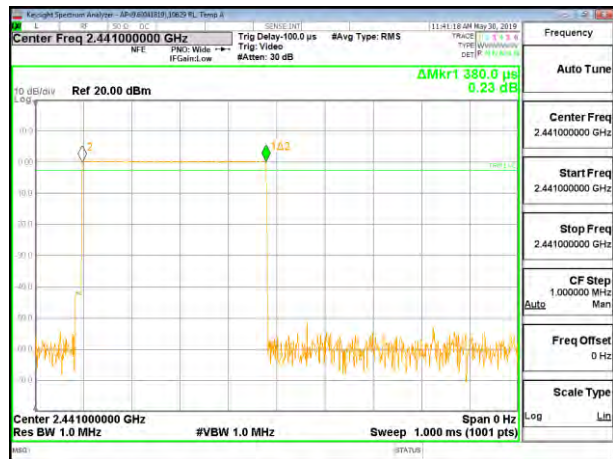

PULSE WIDTH – DH1



PULSE WIDTH – DH3



PULSE WIDTH – DH5

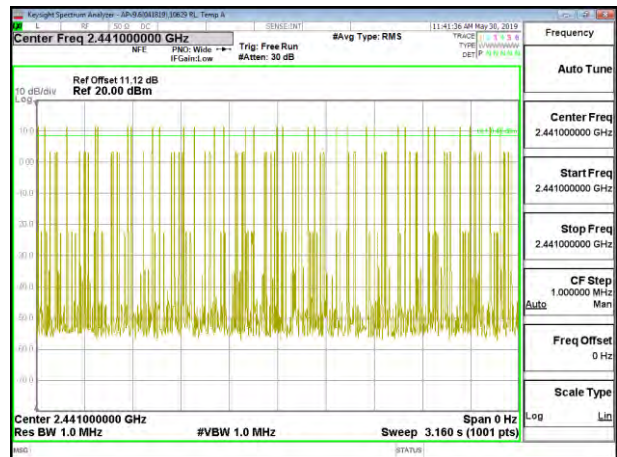

NUMBER OF PULSES IN 3.16 SECOND OBSERVATION PERIOD – DH1

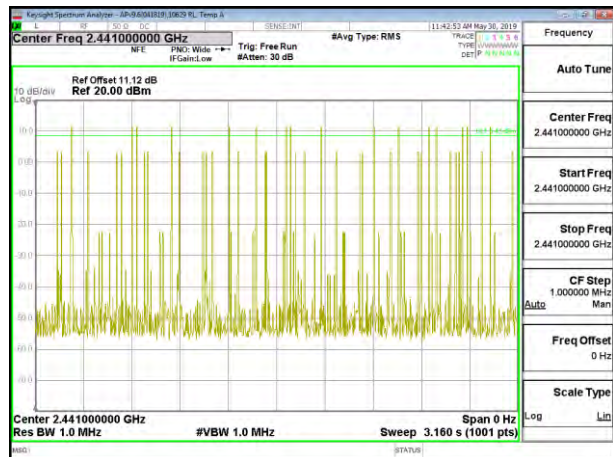

NUMBER OF PULSES IN 3.16 SECOND OBSERVATION PERIOD – DH3

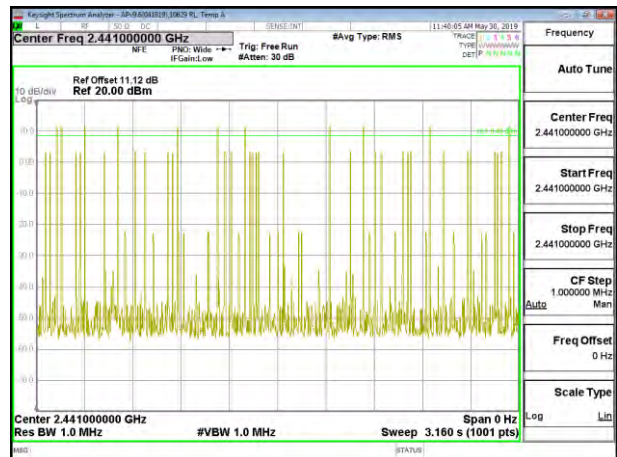

NUMBER OF PULSES IN 3.16 SECOND OBSERVATION PERIOD – DH5

8.5.2. BLUETOOTH ENHANCED DATA RATE 8PSK MODULATION

DH Packet	Pulse Width (msec)	Number of Pulses in 3.16 seconds	Average Time of Occupancy (sec)	Limit (sec)	Margin (sec)
8PSK Normal Mode					
3DH1	1.144	31	0.35464	0.4	-0.0454
3DH3	0.386	15	0.0579	0.4	-0.3421
3DH5	2.888	9	0.25992	0.4	-0.1401

Note: for AFH(8PSK) mode, please refer to the results of AFH(GFSK) mode; the channel selection and hopping rate are the same for both EDR and Basic Rate operation, data for Basic Rate demonstrates compliance with channel occupancy when AFH is employed.

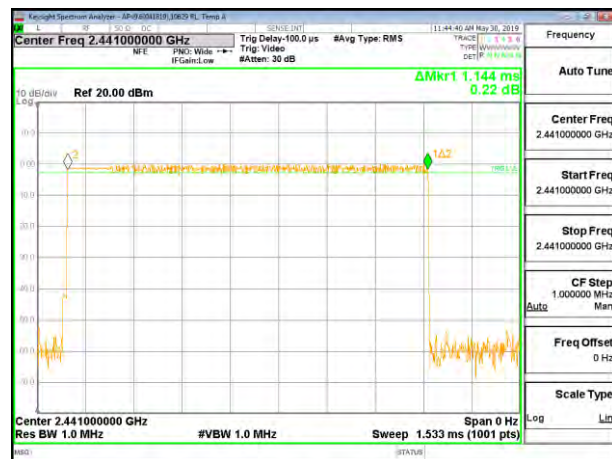

PULSE WIDTH – 3DH1

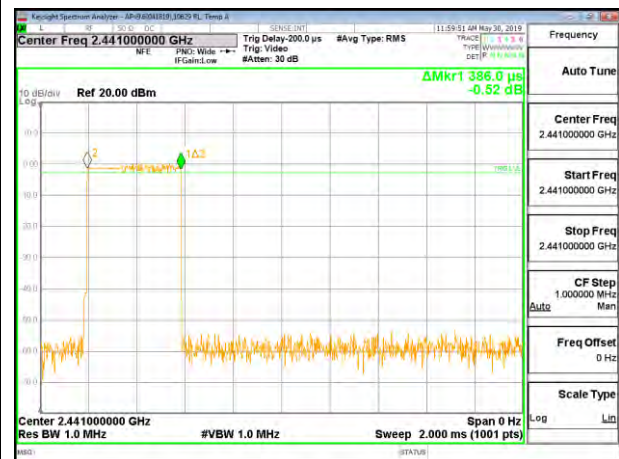

PULSE WIDTH – 3DH3

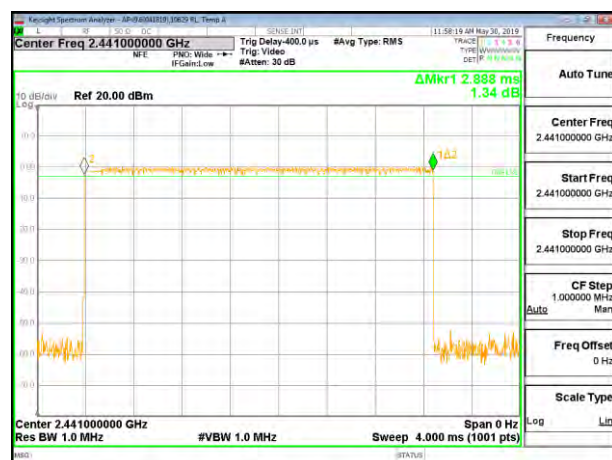

PULSE WIDTH – 3DH5

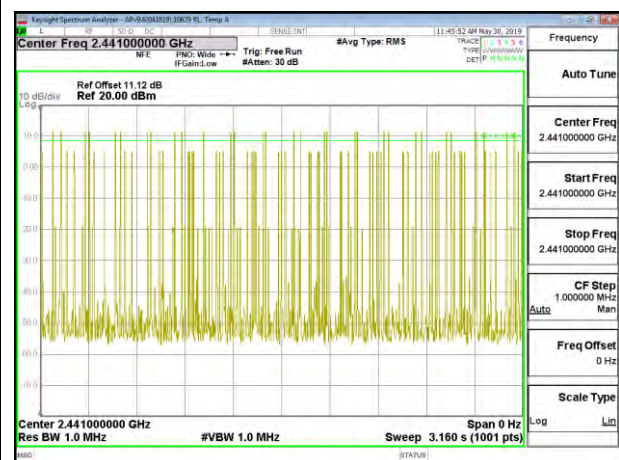

**NUMBER OF PULSES IN 3.16 SECOND
 OBSERVATION PERIOD – 3DH1**

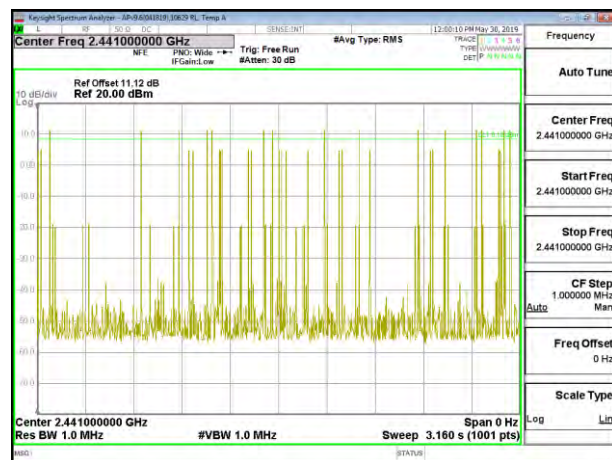

**NUMBER OF PULSES IN 3.16 SECOND
 OBSERVATION PERIOD – 3DH3**

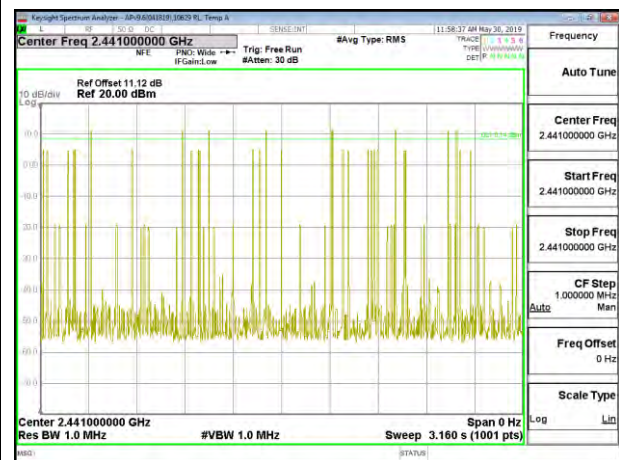

**NUMBER OF PULSES IN 3.16 SECOND
 OBSERVATION PERIOD – 3DH5**

8.6. OUTPUT POWER

LIMITS

§15.247 (b) (1)

RSS-247 (5.4) (b)

The maximum antenna gain is less than 6 dBi, therefore the limit is 30 dBm. Alternatively, frequency hopping systems operating in the 2400-2483.5 MHz band may have hopping channel carrier frequencies that are separated by 25 kHz or two-thirds of the 20 dB bandwidth of the hopping channel, whichever is greater, provided the systems operate with an output power no greater than 125 mW.

TEST PROCEDURE

Measurements perform using a wideband gated RF power meter. The cable assembly insertion loss was entered as an offset in the power meter to allow for a gated peak reading of power.

RESULTS

8.6.1. BLUETOOTH BASIC DATA RATE GFSK MODULATION

Tested By:	10629 RL
Date:	5/30/2019

Channel	Frequency (MHz)	Output Power (dBm)	Limit (dBm)	Margin (dB)
Low	2402	12.81	30	-17.19
Middle	2441	12.51	30	-17.49
High	2480	12.85	30	-17.15

8.6.2. BLUETOOTH ENHANCED DATA RATE DQPSK MODULATION

Tested By:	10629 RL
Date:	5/30/2019

Channel	Frequency (MHz)	Output Power (dBm)	Limit (dBm)	Margin (dB)
Low	2402	12.66	21	-8.34
Middle	2441	12.41	21	-8.59
High	2480	12.64	21	-8.36

8.6.3. BLUETOOTH ENHANCED DATA RATE 8PSK MODULATION

Tested By:	10629 RL
Date:	5/30/2019

Channel	Frequency (MHz)	Output Power (dBm)	Limit (dBm)	Margin (dB)
Low	2402	13.18	21	-7.82
Middle	2441	12.81	21	-8.19
High	2480	13.15	21	-7.85

8.7. AVERAGE POWER

LIMITS

None; for reporting purposes only

TEST PROCEDURE

Measurements perform using a wideband gated RF power meter.

The cable assembly insertion loss of 11.12 dB (including 10 dB pad and 1.12 dB cable) was entered as an offset in the power meter to allow for a gated average reading of power.

RESULTS

8.7.1. BLUETOOTH BASIC DATA RATE GFSK MODULATION

Tested By:	10629 RL
Date	5/30/2019

Channel	Frequency (MHz)	Average Power (dBm)
Low	2402	12.46
Middle	2441	12.2
High	2480	12.5

8.7.2. BLUETOOTH ENHANCED DATA RATE DQPSK MODULATION

Tested By:	10629 RL
Date	5/30/2019

Channel	Frequency (MHz)	Average Power (dBm)
Low	2402	9.93
Middle	2441	9.94
High	2480	10.03

8.7.3. BLUETOOTH ENHANCED DATA RATE 8PSK MODULATION

Tested By:	10629 RL
Date	5/30/2019

Channel	Frequency (MHz)	Average Power (dBm)
Low	2402	10.21
Middle	2441	10.13
High	2480	10.27

8.8. CONDUCTED SPURIOUS EMISSIONS

LIMITS

FCC §15.247 (d)

RSS-247 5.5

Limit = -20 dBc

TEST PROCEDURE

The transmitter output is connected to a spectrum analyzer. The resolution bandwidth is set to 100 kHz. The video bandwidth is set to 300 kHz.

The spectrum from 30 MHz to 26 GHz is investigated with the transmitter set to the lowest, middle, and highest channels.

The bandedges at 2.4 and 2.4835 GHz are investigated with the transmitter set to the normal hopping mode.

RESULTS

8.8.1. BLUETOOTH BASIC DATA RATE GFSK MODULATION

Antenna 1 SPURIOUS EMISSIONS, NON-HOPPING

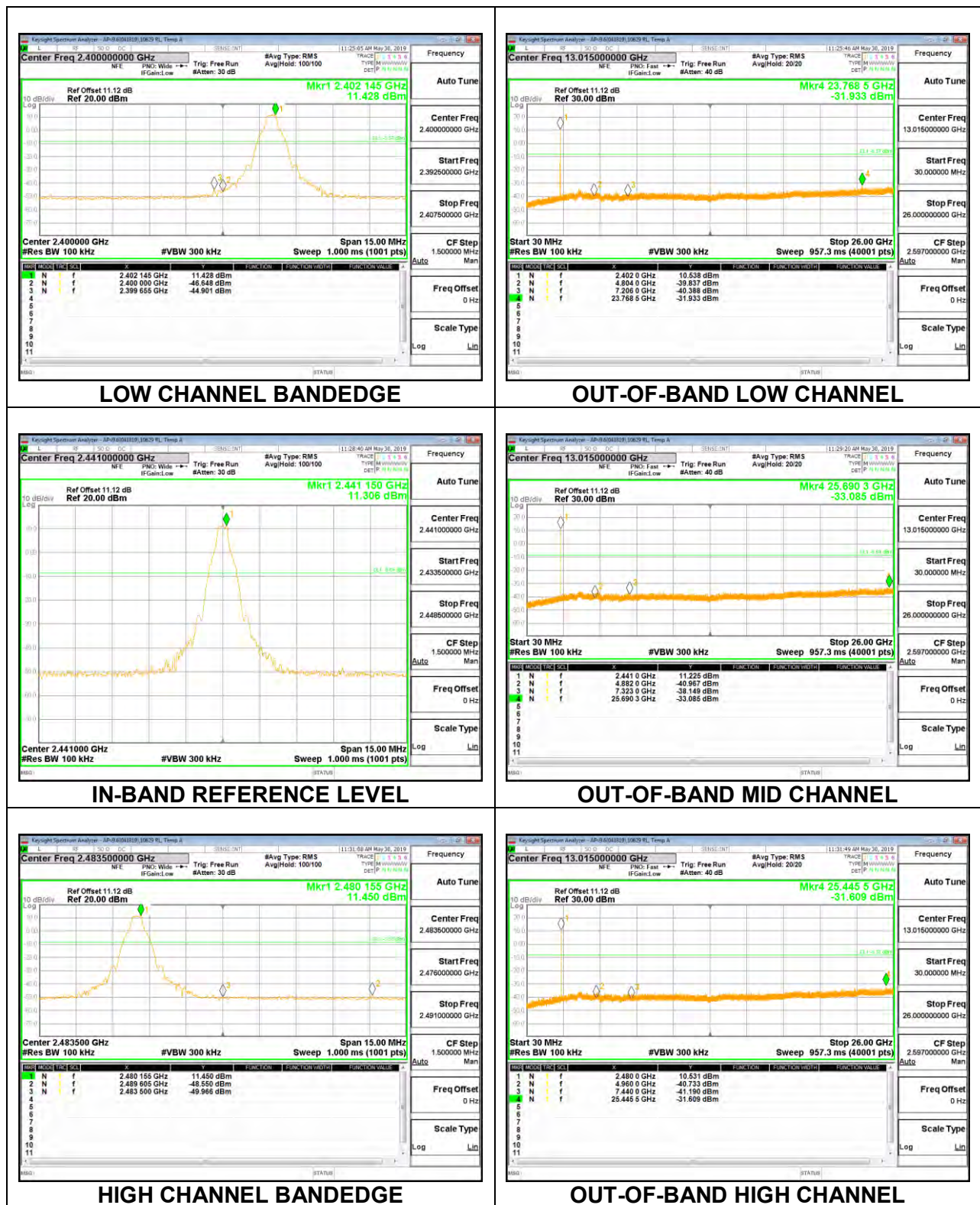

Antenna 1 SPURIOUS BANDEDGE EMISSIONS WITH HOPPING ON

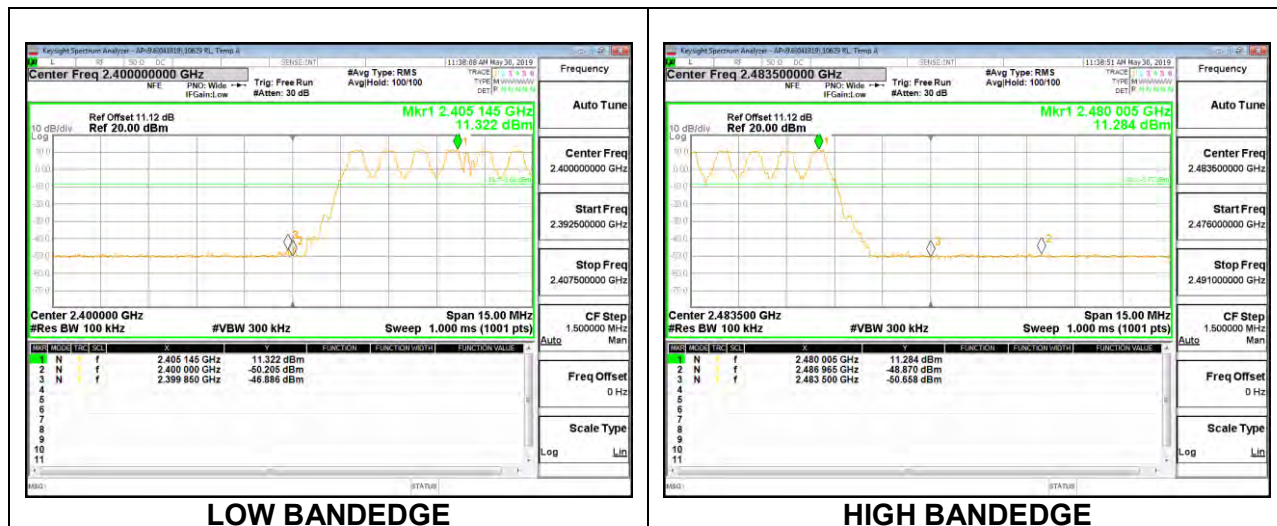

8.8.2. BLUETOOTH ENHANCED DATA RATE 8PSK MODULATION

Antenna 1 SPURIOUS EMISSIONS, NON-HOPPING

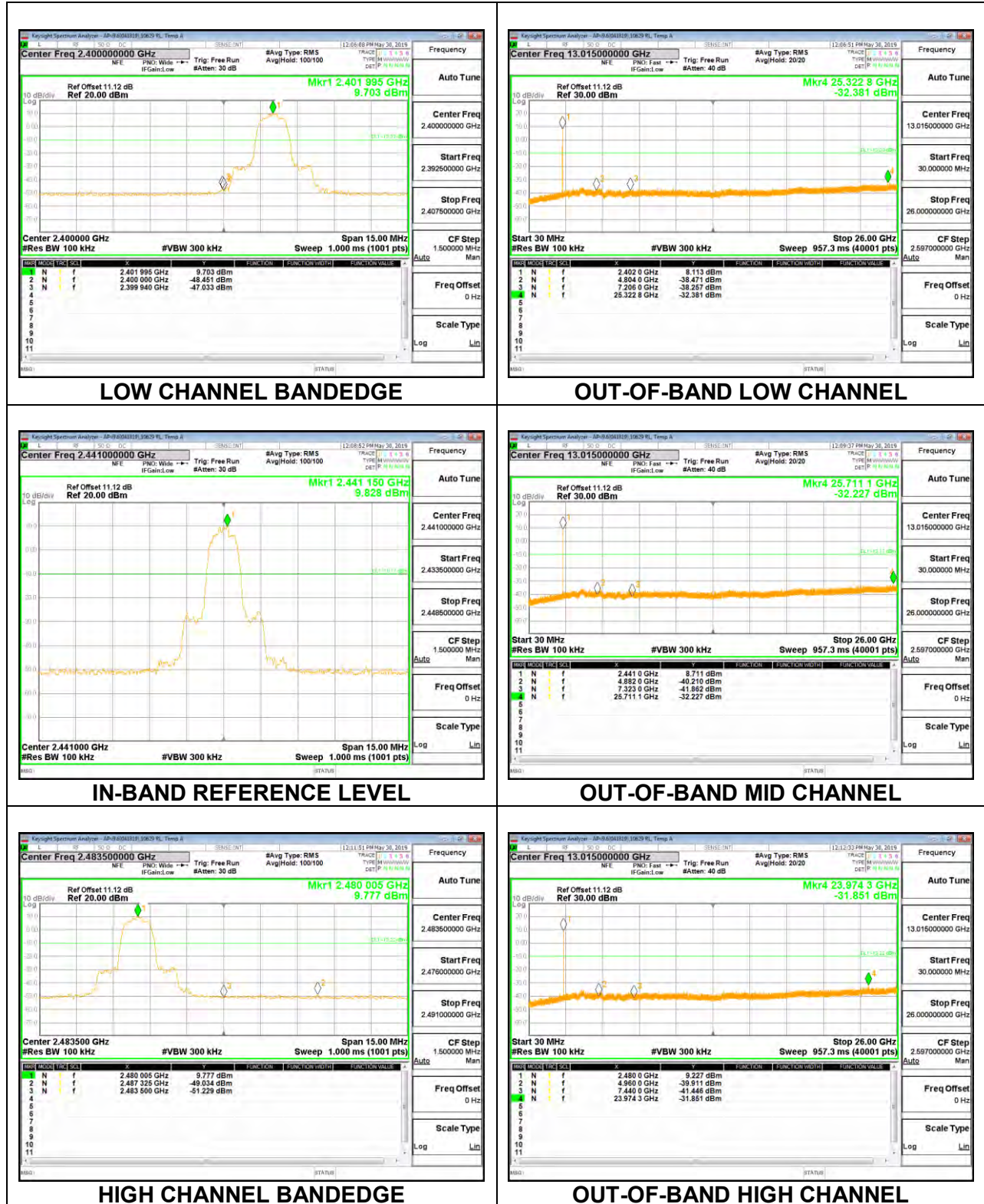

Antenna 1 SPURIOUS BANDEDGE EMISSIONS WITH HOPPING ON

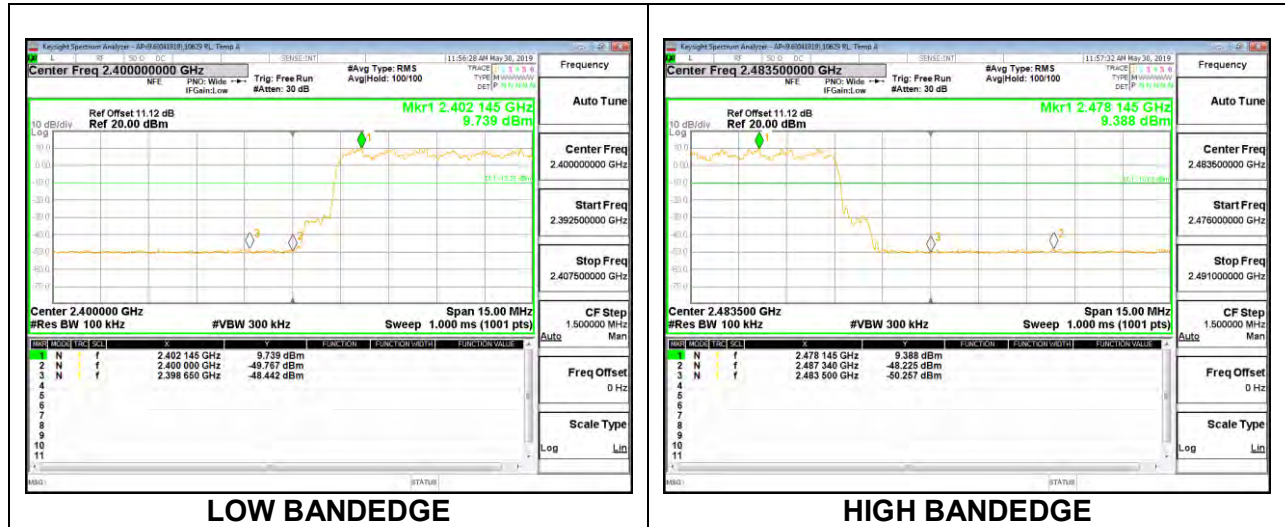

9. RADIATED TEST RESULTS

LIMITS

FCC §15.205 and §15.209

RSS-GEN, Section 8.9 and 8.10.

Frequency Range (MHz)	Field Strength Limit (uV/m) at 3 m	Field Strength Limit (dBuV/m) at 3 m
0.009-0.490	2400/F(kHz) @ 300 m	-
0.490-1.705	24000/F(kHz) @ 30 m	-
1.705 - 30	30 @ 30m	-
30 - 88	100	40
88 - 216	150	43.5
216 - 960	200	46
Above 960	500	54

TEST PROCEDURE

The EUT is placed on a non-conducting table 80 cm above the ground plane for measurement below 1GHz; 1.5 m above the ground plane for measurement above 1GHz. The antenna to EUT distance is 3 meters. The EUT is configured in accordance with ANSI C63.10. The EUT is set to transmit in a continuous mode.

For measurements below 1 GHz the resolution bandwidth is set to 100 kHz for peak detection measurements or 120 kHz for quasi-peak detection measurements. Peak detection is used unless otherwise noted as quasi-peak.

For pre-scans above 1 GHz the resolution bandwidth is set to 1 MHz; the video bandwidth is set to 30 KHz for peak measurements.

For final measurements above 1 GHz the resolution bandwidth is set to 1 MHz; the video bandwidth is set to 3 MHz for peak measurements and as applicable for average measurements.

The spectrum from 1 GHz to 18 GHz is investigated with the transmitter set to the lowest, middle, and highest channels in each applicable band. Below 1GHz and above 18GHz emissions, the channel with the highest output power was tested.

The frequency range of interest is monitored at a fixed antenna height and EUT azimuth. The EUT is rotated through 360 degrees to maximize emissions received. The antenna is scanned from 1 to 4 meters above the ground plane to further maximize the emission. Measurements are made with the antenna polarized in both the vertical and the horizontal positions.

For below 30MHz testing, investigation was done on three antenna orientations (parallel, perpendicular, and ground-parallel), parallel and perpendicular are the worst orientations, therefore testing was performed on these two orientations only.

KDB 414788 Open Field Site (OFS) and Chamber Correlation Justification

Base on FCC 15.31 (f) (2): measurements may be performed at a distance closer than that specified in the regulations; however, an attempt should be made to avoid making measurements in the near field.

OFS and chamber correlation testing had been performed and chamber measured test result is the worst-case test result.

9.1. TRANSMITTER ABOVE 1 GHz

9.1.1. BLUETOOTH BASIC DATA RATE GFSK MODULATION

BANDEDGE (LOW CHANNEL)

HORIZONTAL RESULT

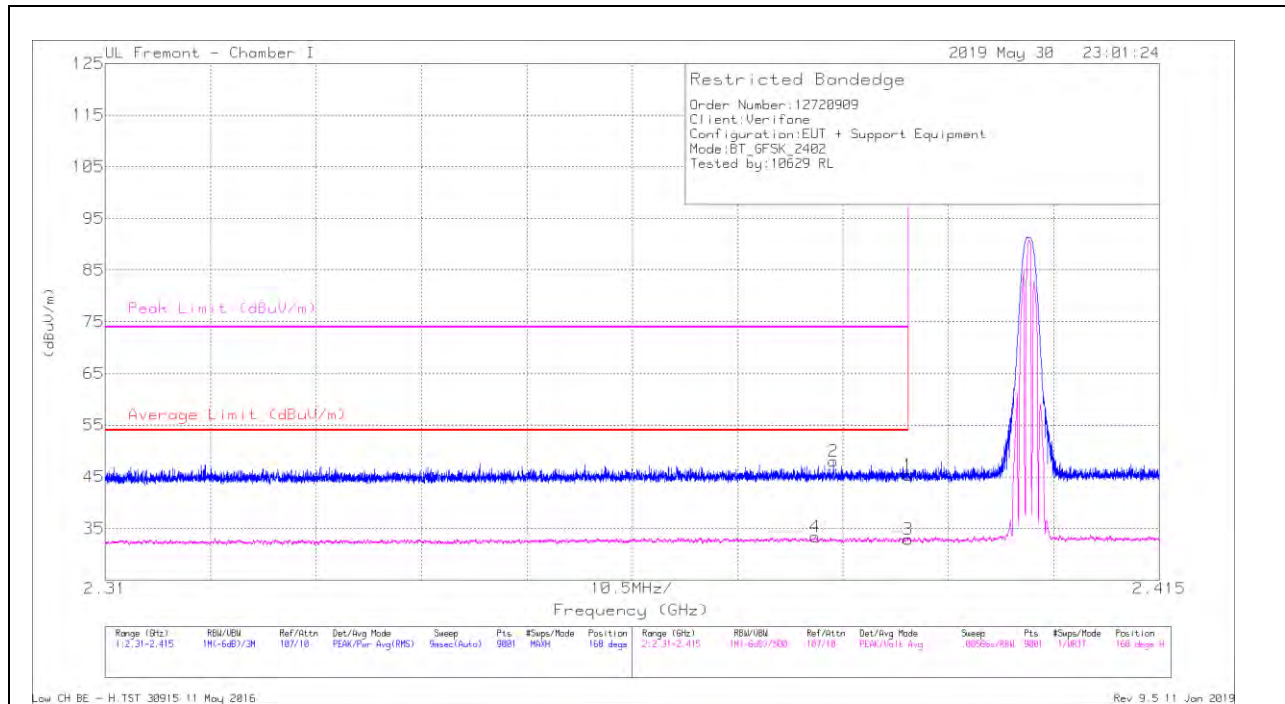

Trace Markers

Marker	Frequency (GHz)	Meter Reading (dBuV)	Det	AF PRE0190810 (dB/m)	Amp/Cbl/Filtr/Pad (dB)	Corrected Reading (dBuV/m)	Average Limit (dBuV/m)	Margin (dB)	Peak Limit (dBuV/m)	PK Margin (dB)	Azimuth (Degs)	Height (cm)	Polarity
1	* 2.39	38.02	Pk	28.9	-21.6	45.32	-	-	74	-28.68	168	187	H
2	* 2.383	40.69	Pk	28.9	-21.6	47.99	-	-	74	-26.01	168	187	H
3	* 2.39	25.59	VA1T	28.9	-21.6	32.89	54	-21.11	-	-	168	187	H
4	* 2.381	25.97	VA1T	28.9	-21.5	33.37	54	-20.63	-	-	168	187	H

* - indicates frequency in CFR47 Pt 15 / IC RSS-Restricted Band

Pk - Peak detector

VA1T - FHSS: Linear Voltage Average $V_B=1/T_{on}$ where: T_{on} is transmit duration

VERTICAL RESULT

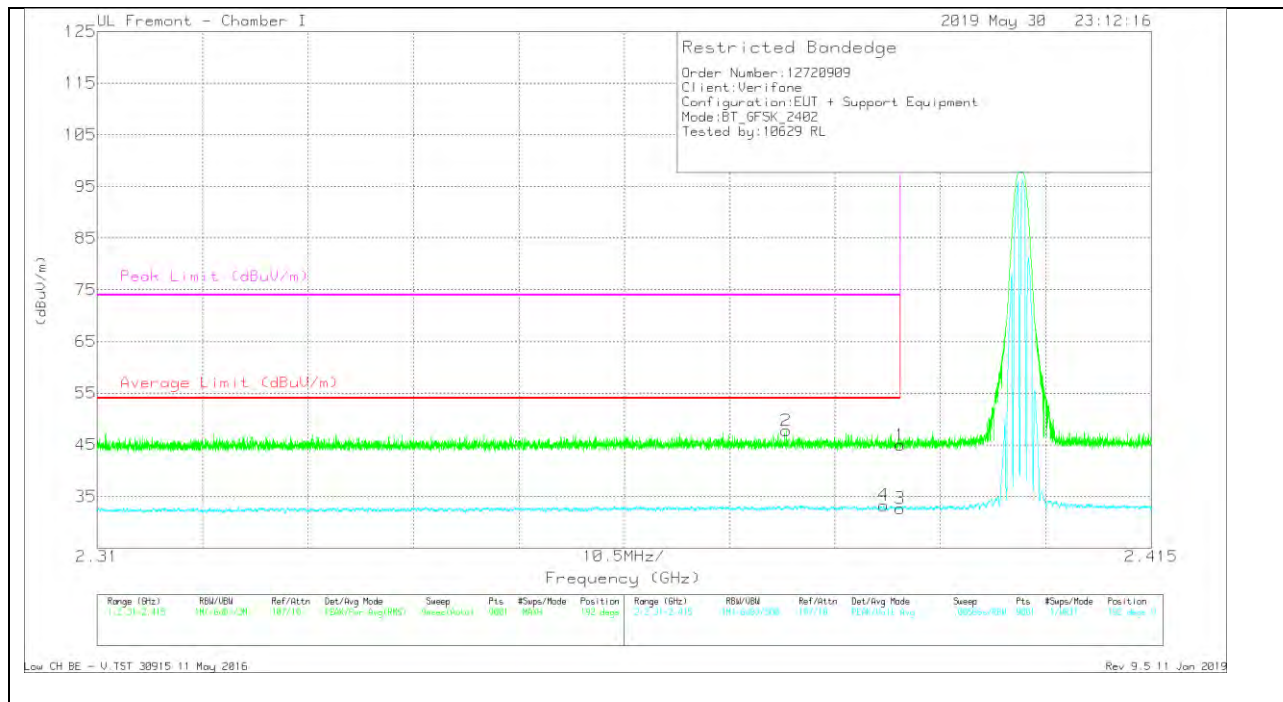

Trace Markers

Marker	Frequency (GHz)	Meter Reading (dBuV)	Det	AF PRE0190810 (dB/m)	Amp/Cbl/Filtr/Pad (dB)	Corrected Reading (dBuV/m)	Average Limit (dBuV/m)	Margin (dB)	Peak Limit (dBuV/m)	PK Margin (dB)	Azimuth (Degs)	Height (cm)	Polarity
1	*2.39	37.65	PK	28.9	-21.6	44.95	-	-	74	-29.05	192	101	V
2	*2.379	40.35	PK	28.9	-21.5	47.75	-	-	74	-26.25	192	101	V
3	*2.39	25.37	VA1T	28.9	-21.6	32.67	54	-21.33	-	-	192	101	V
4	*2.368	26.01	VA1T	28.9	-21.6	33.31	54	-20.69	-	-	192	101	V

* - indicates frequency in CFR47 Pt 15 / IC RSS-Restricted Band
 Pk - Peak detector
 VA1T - FHSS: Linear Voltage Average VB=1/Ton where: Ton is transmitting duration

BANEDGE (HIGH CHANNEL)

HORIZONTAL RESULT

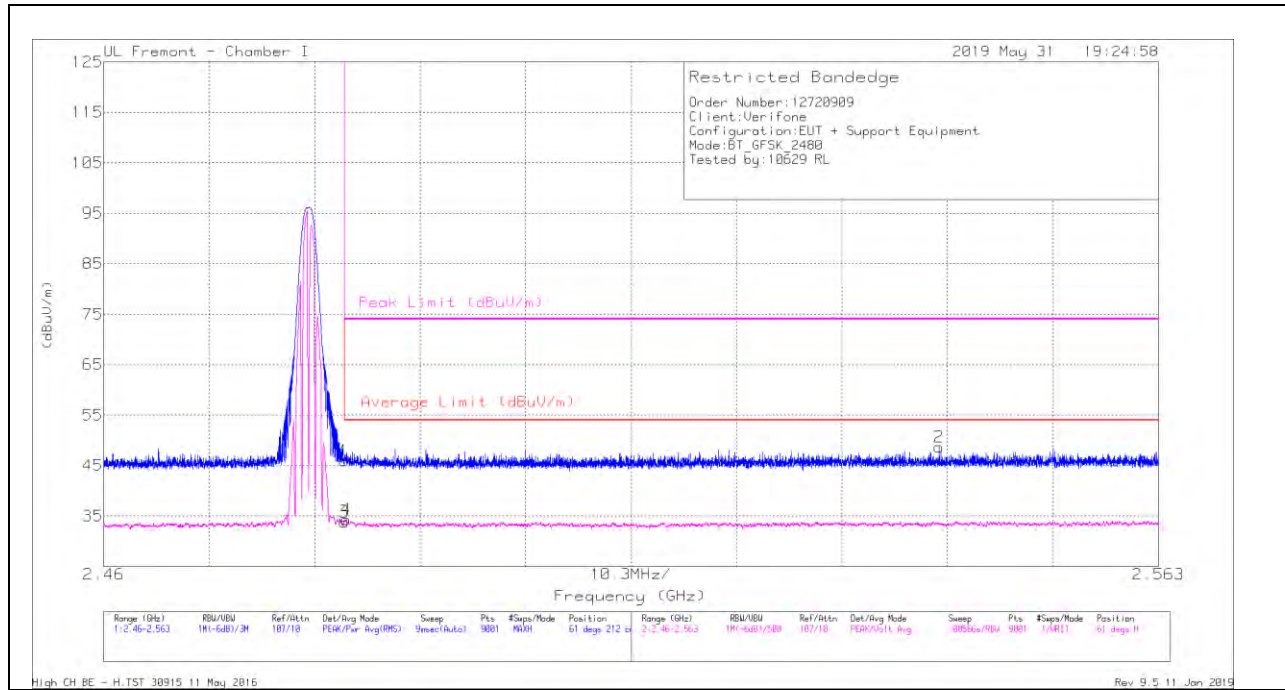

Trace Markers

Marker	Frequency (GHz)	Meter Reading (dBuV)	Det	AF PRE019081 0 (dB/m)	Amp/Cbl/Fit r/Pad (dB)	Corrected Reading (dBuV/m)	Average Limit (dBuV/m)	Margin (dB)	Peak Limit (dBuV/m)	PK Margin (dB)	Azimuth (Degs)	Height (cm)	Polarity
1	* 2.484	38.28	Pk	29.4	-21.7	45.98	-	-	74	-28.02	61	212	H
2	2.542	40.86	Pk	29.6	-21.8	48.66	-	-	74	-25.34	61	212	H
3	* 2.484	26.14	VA1T	29.4	-21.7	33.84	54	-20.16	-	-	61	212	H
4	* 2.484	26.53	VA1T	29.4	-21.7	34.23	54	-19.77	-	-	61	212	H

* - indicates frequency in CFR47 Pt 15 / IC RSS-Restricted Band

Pk - Peak detector

VA1T - FHSS: Linear Voltage Average VB=1/Ton where: Ton is transmitting duration

VERTICAL RESULT

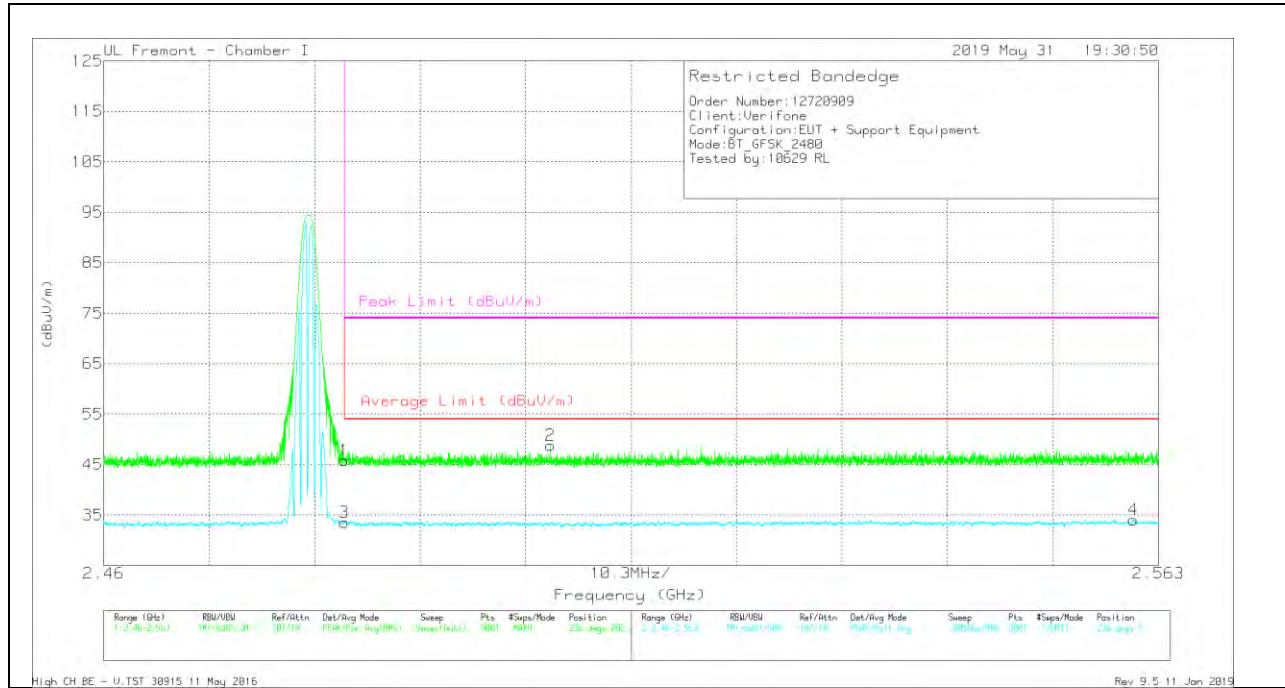

Trace Markers

Marker	Frequency (GHz)	Meter Reading (dBuV)	Det	AF PRE019081 0 (dB/m)	Amp/Cbl/Fit r/Pad (dB)	Corrected Reading (dBuV/m)	Average Limit (dBuV/m)	Margin (dB)	Peak Limit (dBuV/m)	PK Margin (dB)	Azimuth (Degs)	Height (cm)	Polarity
1	* 2.484	38.15	Pk	29.4	-21.7	45.85	-	-	74	-28.15	236	282	V
2	2.504	41.12	Pk	29.5	-21.8	48.82	-	-	74	-25.18	236	282	V
3	* 2.484	25.79	VA1T	29.4	-21.7	33.49	54	-20.51	-	-	236	282	V
4	2.561	25.96	VA1T	29.7	-21.6	34.06	54	-19.94	-	-	236	282	V

* - indicates frequency in CFR47 Pt 15 / IC RSS-Restricted Band
 Pk - Peak detector
 VA1T - FHSS: Linear Voltage Average VB=1/Ton where: Ton is transmitting duration

HARMONICS AND SPURIOUS EMISSIONS

LOW CHANNEL RESULTS

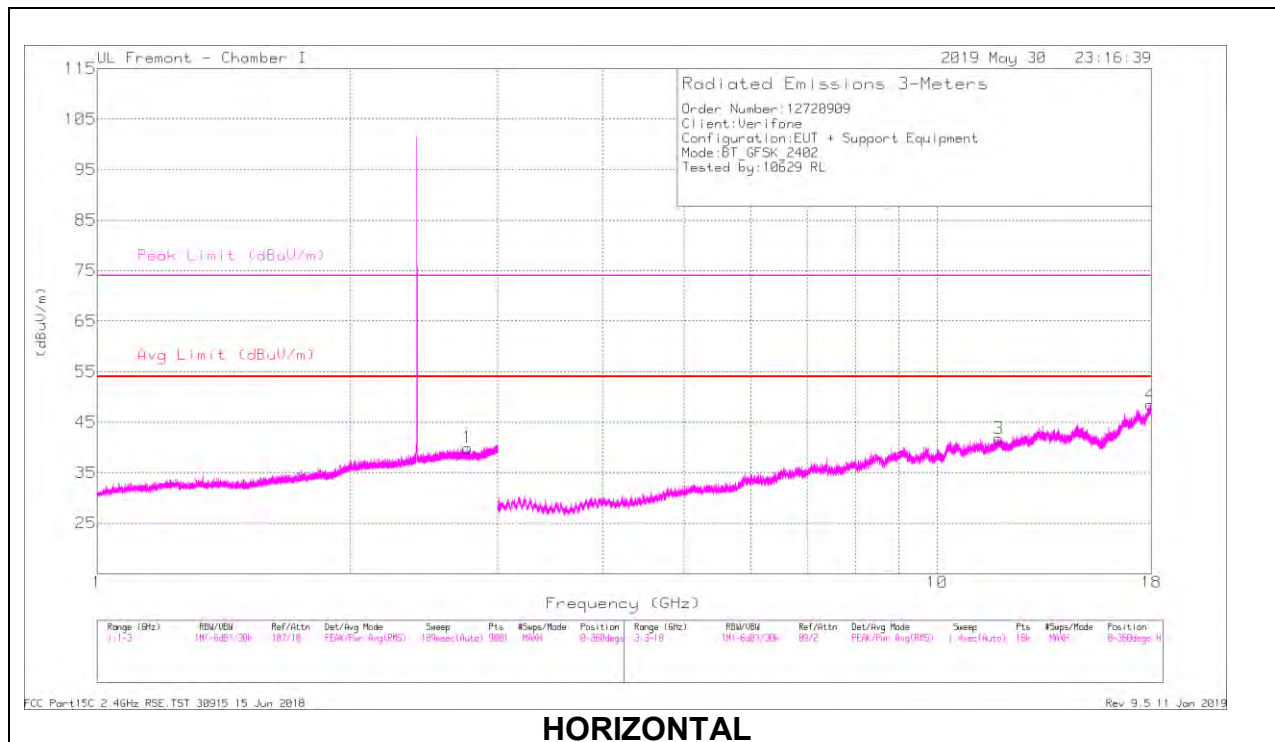

HORIZONTAL

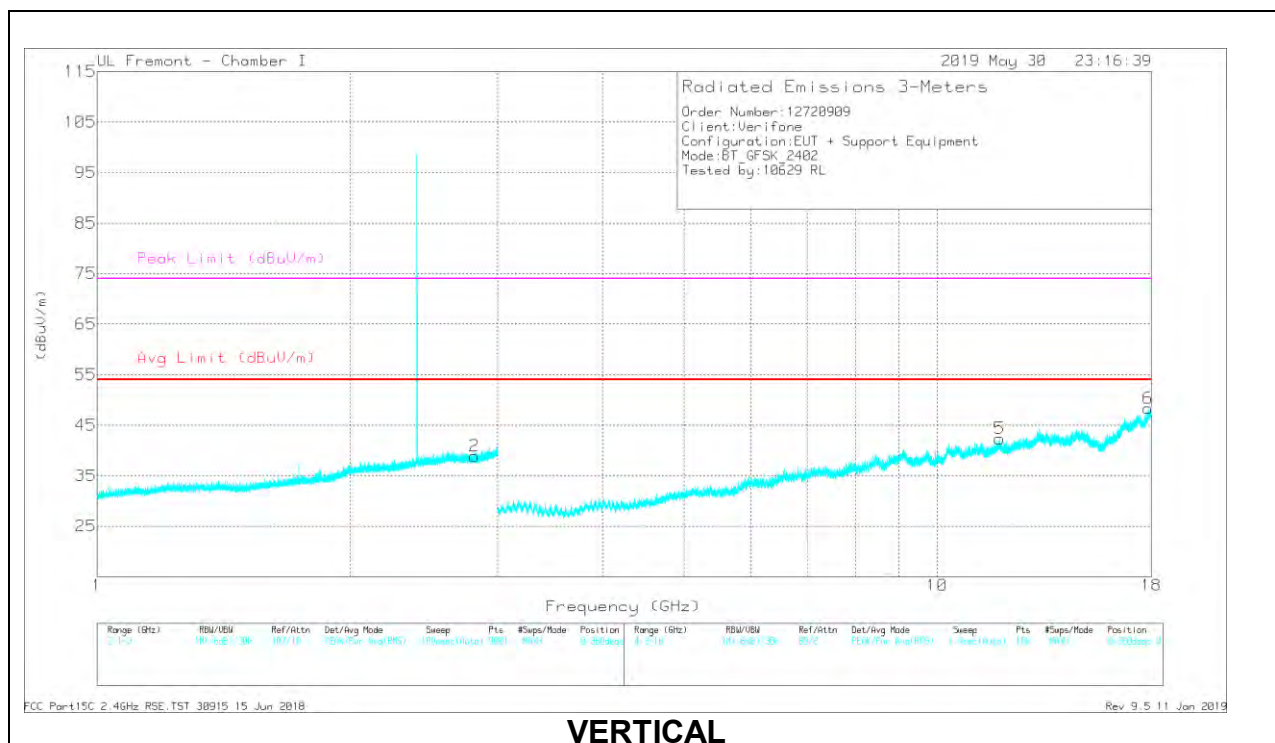

VERTICAL

RADIATED EMISSIONS

Marker	Frequency (GHz)	Meter Reading (dBuV)	Det	AF PRE0190810 (dB/m)	Amp/Cbl/Fitr/Pad (dB)	Corrected Reading (dBuV/m)	Avg Limit (dBuV/m)	Margin (dB)	Peak Limit (dBuV/m)	PK Margin (dB)	Azimuth (Degs)	Height (cm)	Polarity
1	* 2.759	38.53	PKFH	29.3	-20.9	46.93	-	-	74	-27.07	83	279	H
	* 2.761	25.77	VA1T	29.3	-20.9	34.17	54	-19.83	-	-	83	279	H
2	* 2.815	37.6	PKFH	29.3	-20.9	46	-	-	74	-28	263	290	V
	* 2.817	25.65	VA1T	29.3	-20.9	34.05	54	-19.95	-	-	263	290	V
3	* 11.841	31.17	PKFH	39.1	-20.8	49.47	-	-	74	-24.53	23	335	H
	* 11.842	18.2	VA1T	39.1	-20.8	36.5	54	-17.5	-	-	23	335	H
4	* 17.968	28.29	PKFH	43.2	-15.5	55.99	-	-	74	-18.01	110	116	H
	* 17.97	15.54	VA1T	43.2	-15.5	43.24	54	-10.76	-	-	110	116	H
5	* 11.876	31.22	PKFH	39.1	-20.8	49.52	-	-	74	-24.48	99	237	V
	* 11.876	18.41	VA1T	39.1	-20.8	36.71	54	-17.29	-	-	99	237	V
6	* 17.854	28	PKFH	42.6	-14.7	55.9	-	-	74	-18.1	71	262	V
	* 17.853	14.7	VA1T	42.6	-14.6	42.7	54	-11.3	-	-	71	262	V

* - indicates frequency in CFR47 Pt 15 / IC RSS-Restricted Band
 PKFH FHSS/BT RB=100k for Frequencies<1GHz / RB=1MHz for Frequencies>1GHz, VB=3 x RB, Peak
 VA1T - FHSS: Linear Voltage Average VB=1/T on where: Ton is transmitting duration

MID CHANNEL RESULTS

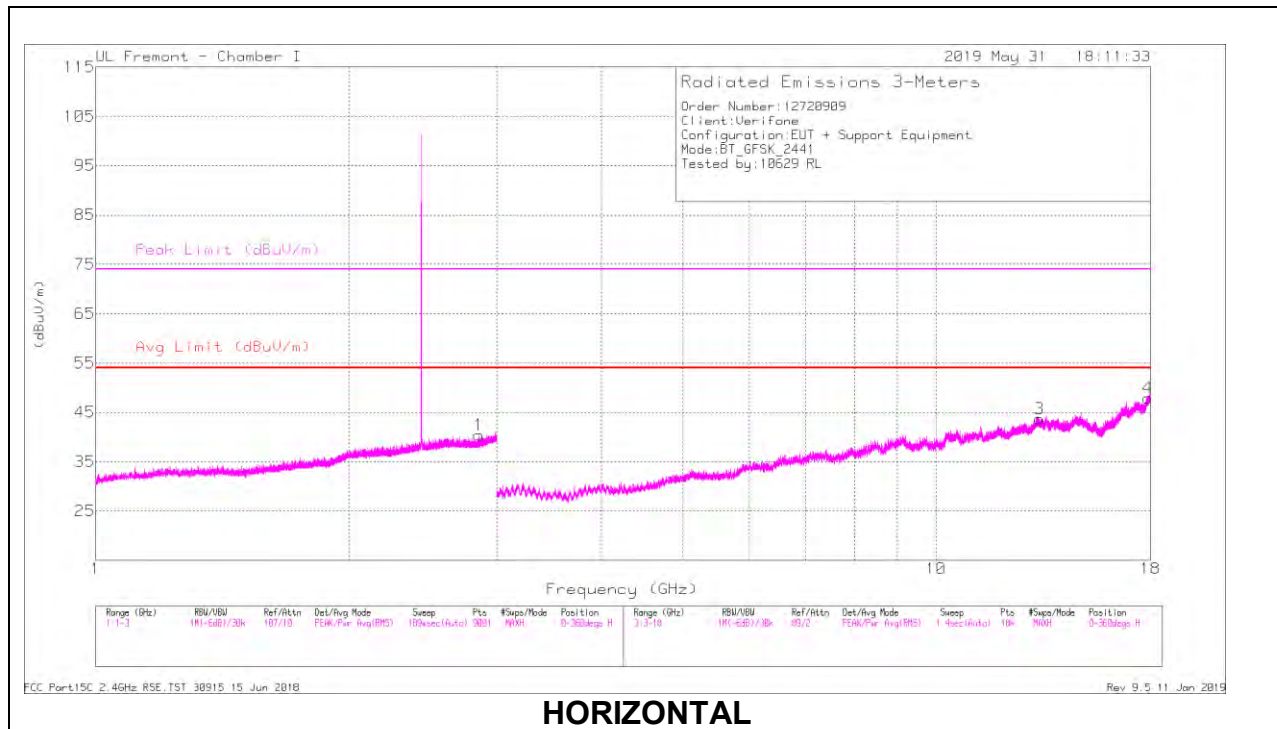

HORIZONTAL

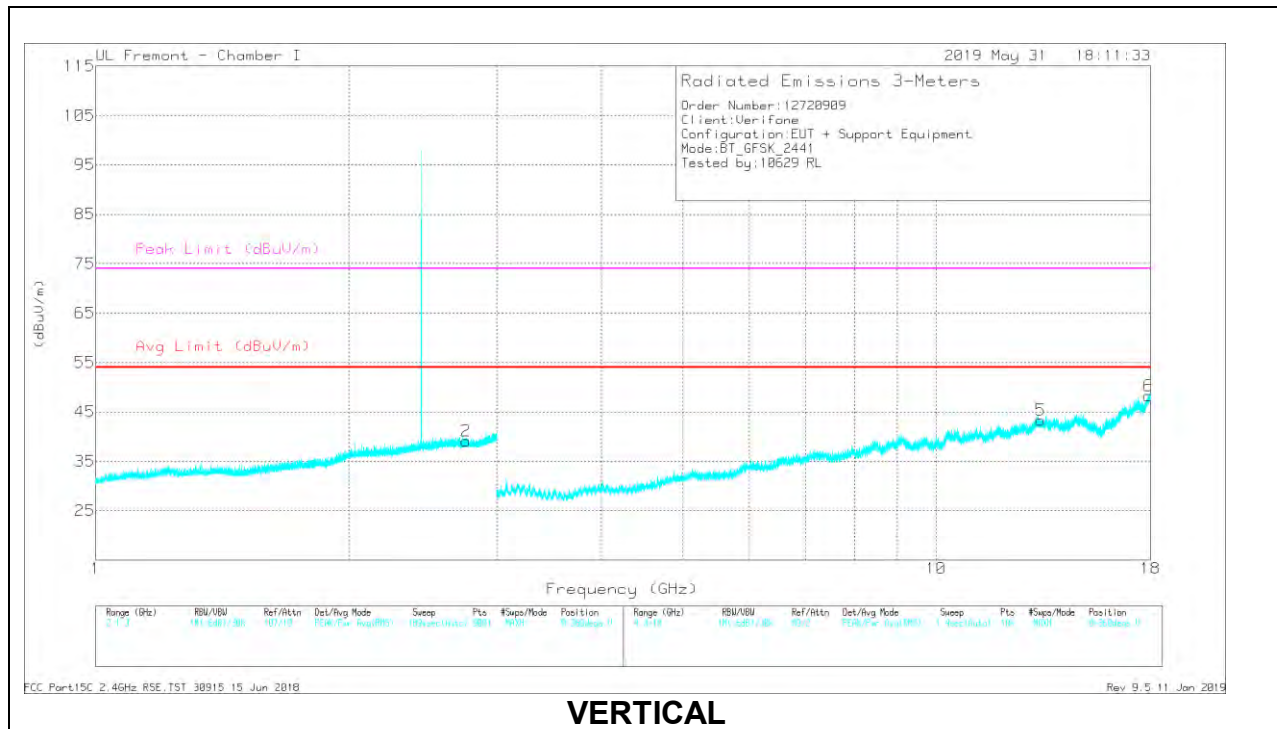

VERTICAL

RADIATED EMISSIONS

Marker	Frequency (GHz)	Meter Reading (dBuV)	Det	AF PRE0190810 (dB/m)	Amp/Cbl/Fitr/Pad (dB)	Corrected Reading (dBuV/m)	Avg Limit (dBuV/m)	Margin (dB)	Peak Limit (dBuV/m)	PK Margin (dB)	Azimuth (Degs)	Height (cm)	Polarity
1	* 2.858	38.33	PKFH	29.5	-20.9	46.93	-	-	74	-27.07	233	167	H
	* 2.857	25.8	VA1T	29.5	-20.9	34.4	54	-19.6	-	-	233	167	H
2	* 2.761	38.36	PKFH	29.3	-20.9	46.76	-	-	74	-27.24	41	150	V
	* 2.762	25.97	VA1T	29.3	-20.9	34.37	54	-19.63	-	-	41	150	V
3	* 13.282	31.24	PKFH	41.1	-21.6	50.74	-	-	74	-23.26	4	312	H
	* 13.284	18.76	VA1T	41.1	-21.6	38.26	54	-15.74	-	-	4	312	H
4	* 17.874	28.3	PKFH	42.7	-14.8	56.2	-	-	74	-17.8	156	398	H
	* 17.875	15.06	VA1T	42.8	-14.8	43.06	54	-10.94	-	-	156	398	H
5	* 13.321	30.94	PKFH	41.1	-21.5	50.54	-	-	74	-23.46	342	323	V
	* 13.322	18.88	VA1T	41.1	-21.5	38.48	54	-15.52	-	-	342	323	V
6	* 17.912	28.37	PKFH	43	-15.4	55.97	-	-	74	-18.03	193	196	V
	* 17.912	15.16	VA1T	43	-15.4	42.76	54	-11.24	-	-	193	196	V

* - indicates frequency in CFR47 Pt 15 / IC RSS-Restricted Band
 PKFH FHSS/BT RB=100k for Frequencies<1GHz / RB=1MHz for Frequencies>1GHz, VB=3 x RB, Peak
 VA1T - FHSS: Linear Voltage Average VB=1/Ton where: Ton is transmitting duration

HIGH CHANNEL RESULTS

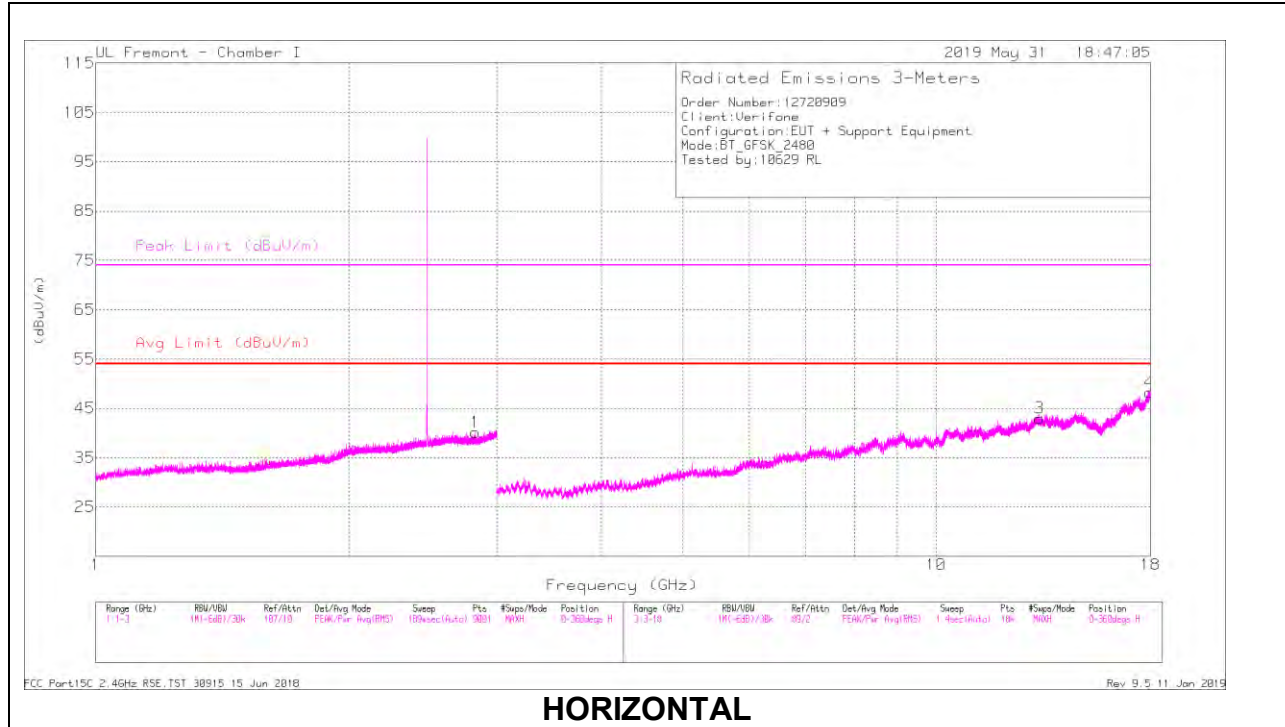

HORIZONTAL

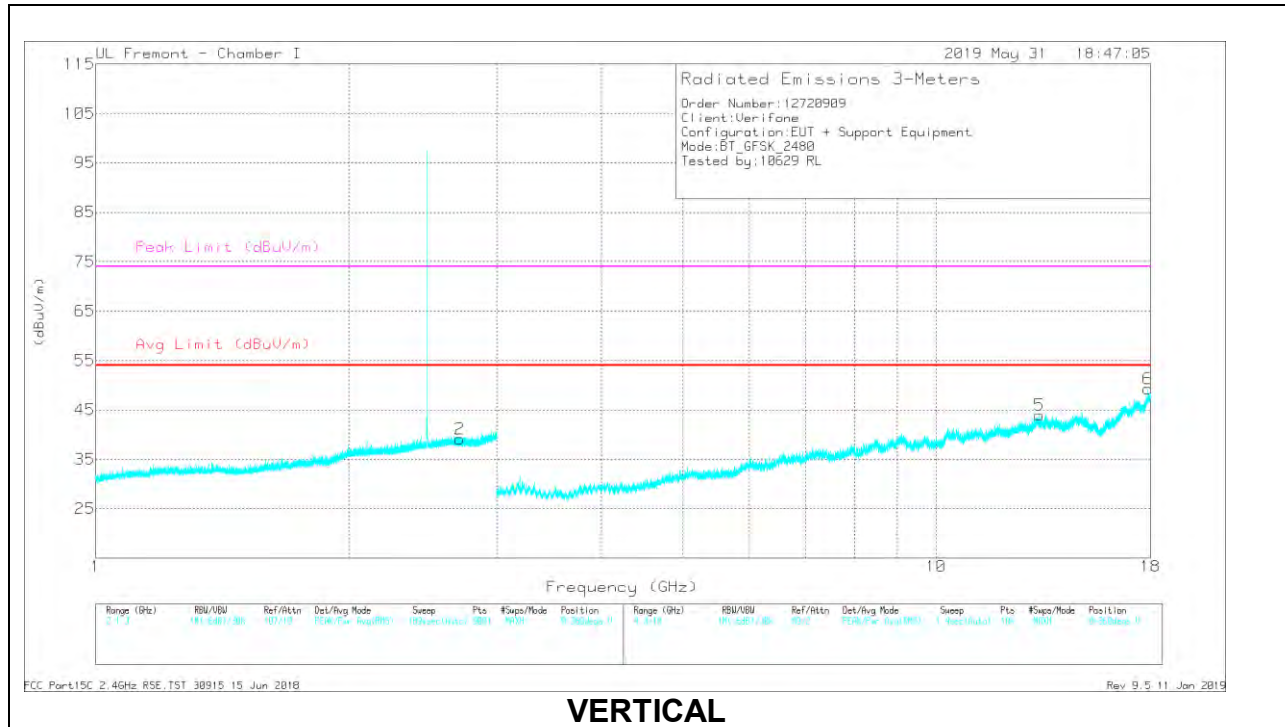

VERTICAL

RADIATED EMISSIONS

Marker	Frequency (GHz)	Meter Reading (dBuV)	Det	AF PRE0190810 (dB/m)	Amp/Cbl/Fitr/Pad (dB)	Corrected Reading (dBuV/m)	Avg Limit (dBuV/m)	Margin (dB)	Peak Limit (dBuV/m)	PK Margin (dB)	Azimuth (Degs)	Height (cm)	Polarity
1	* 2.832	37.79	PKFH	29.4	-20.9	46.29	-	-	74	-27.71	102	144	H
	* 2.831	25.57	VA1T	29.4	-20.9	34.07	54	-19.93	-	-	102	144	H
2	* 2.713	38.14	PKFH	29.4	-21.1	46.44	-	-	74	-27.56	26	176	V
	* 2.711	25.74	VA1T	29.4	-21.1	34.04	54	-19.96	-	-	26	176	V
3	* 13.274	31.87	PKFH	41.1	-21.6	51.37	-	-	74	-22.63	212	134	H
	* 13.272	18.68	VA1T	41.1	-21.5	38.28	54	-15.72	-	-	212	134	H
4	* 17.974	28.49	PKFH	43.3	-15.5	56.29	-	-	74	-17.71	133	306	H
	* 17.974	15.66	VA1T	43.3	-15.5	43.46	54	-10.54	-	-	133	306	H
5	* 13.273	31.87	PKFH	41.1	-21.6	51.37	-	-	74	-22.63	332	120	V
	* 13.272	18.75	VA1T	41.1	-21.6	38.25	54	-15.75	-	-	332	120	V
6	* 17.88	28.05	PKFH	42.8	-15	55.85	-	-	74	-18.15	83	251	V
	* 17.879	14.97	VA1T	42.8	-15	42.77	54	-11.23	-	-	83	251	V

* - indicates frequency in CFR47 Pt 15 / IC RSS-Restricted Band
 PKFH FHSS/BT RB=100k for Frequencies<1GHz / RB=1MHz for Frequencies>1GHz, VB=3 x RB, Peak
 VA1T - FHSS: Linear Voltage Average VB=1/T on where: Ton is transmitting duration

9.1.2. BLUETOOTH ENHANCED DATA RATE 8PSK MODULATION

BANDEDGE (LOW CHANNEL)

HORIZONTAL RESULT

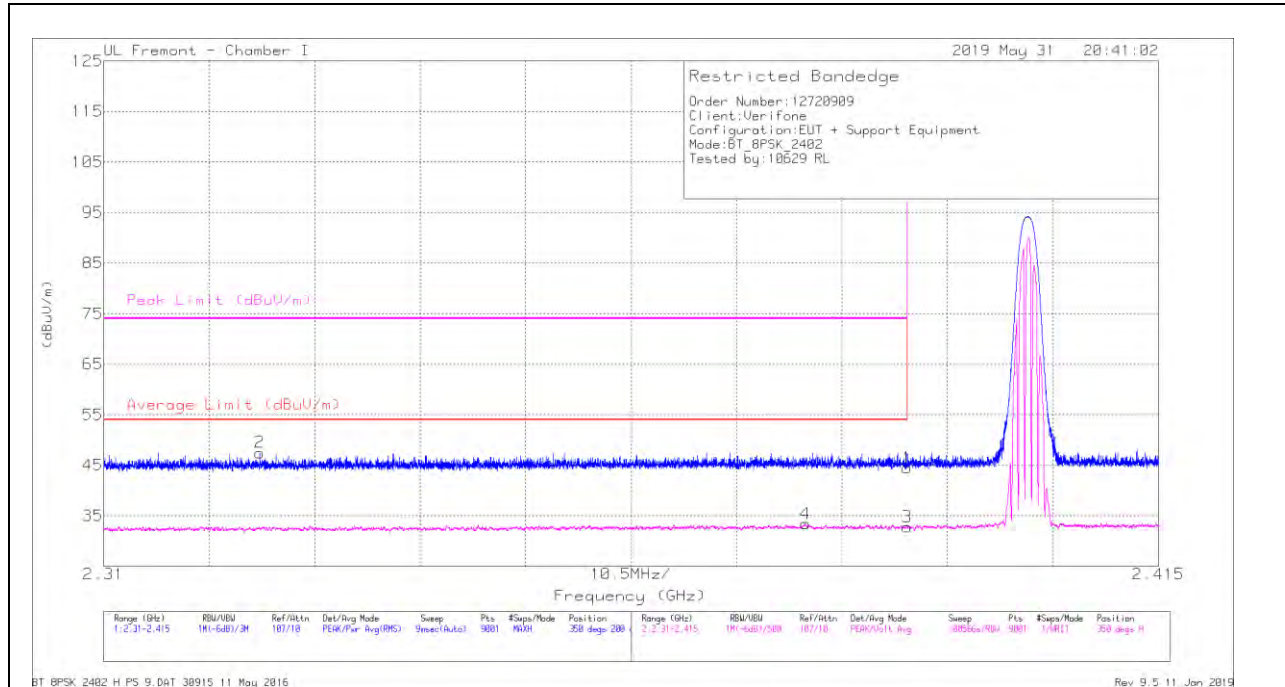

Trace Markers

Marker	Frequency (GHz)	Meter Reading (dBuV)	Det	AF PRE019081 0 (dB/m)	Amp/Cbl/Fit r/Pad (dB)	Corrected Reading (dBuV/m)	Average Limit (dBuV/m)	Margin (dB)	Peak Limit (dBuV/m)	PK Margin (dB)	Azimuth (Degs)	Height (cm)	Polarity
1	* 2.39	37.12	Pk	28.9	-21.6	44.42	-	-	74	-29.58	350	200	H
2	* 2.326	40.6	Pk	28.4	-21.5	47.5	-	-	74	-26.5	350	200	H
3	* 2.39	25.44	VA1T	28.9	-21.6	32.74	54	-21.26	-	-	350	200	H
4	* 2.38	26.05	VA1T	28.9	-21.5	33.45	54	-20.55	-	-	350	200	H

* - indicates frequency in CFR47 Pt 15 / IC RSS-Restricted Band

Pk - Peak detector

VA1T - FHSS: Linear Voltage Average VB=1/Ton where: Ton is transmitting duration

VERTICAL RESULT

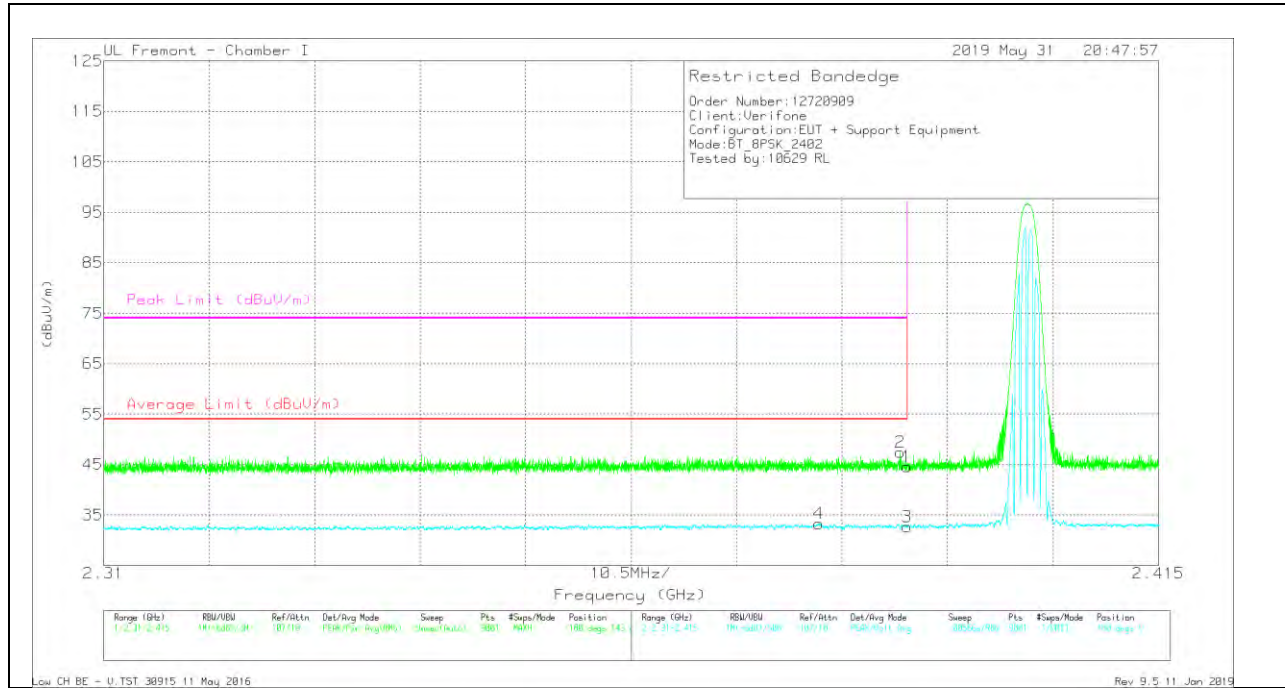

Trace Markers

Marker	Frequency (GHz)	Meter Reading (dBuV)	Det	AF PRE019081 0 (dB/m)	Amp/Cbl/Fit r/Pad (dB)	Corrected Reading (dBuV/m)	Average Limit (dBuV/m)	Margin (dB)	Peak Limit (dBuV/m)	PK Margin (dB)	Azimuth (Degs)	Height (cm)	Polarity
1	* 2.39	37.28	Pk	28.9	-21.6	44.58	-	-	74	-29.42	180	143	V
2	* 2.389	40.1	Pk	28.9	-21.6	47.4	-	-	74	-26.6	180	143	V
3	* 2.39	25.31	VA1T	28.9	-21.6	32.61	54	-21.39	-	-	180	143	V
4	* 2.381	25.97	VA1T	28.9	-21.6	33.27	54	-20.73	-	-	180	143	V

* - indicates frequency in CFR47 Pt 15 / IC RSS-Restricted Band

Pk - Peak detector

VA1T - FHSS: Linear Voltage Average VB=1/Ton where: Ton is transmitting duration

BANEDGE (HIGH CHANNEL)

HORIZONTAL RESULT

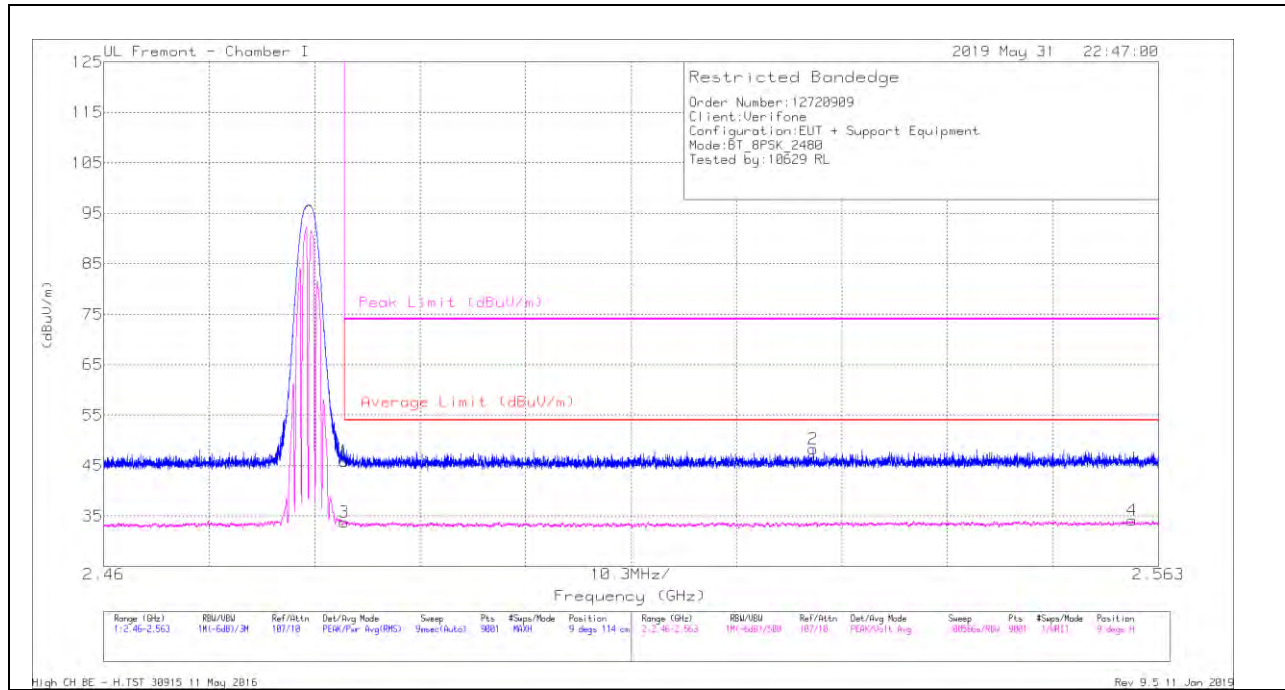

Trace Markers

Marker	Frequency (GHz)	Meter Reading (dBuV)	Det	AF PRE019081 0 (dB/m)	Amp/Cbl/Fit r/Pad (dB)	Corrected Reading (dBuV/m)	Average Limit (dBuV/m)	Margin (dB)	Peak Limit (dBuV/m)	PK Margin (dB)	Azimuth (Degs)	Height (cm)	Polarity
1	* 2.484	38.18	Pk	29.4	-21.7	45.88	-	-	74	-28.12	9	114	H
2	2.529	40.47	Pk	29.5	-21.7	48.27	-	-	74	-25.73	9	114	H
3	* 2.484	26.06	VA1T	29.4	-21.7	33.76	54	-20.24	-	-	9	114	H
4	2.56	26	VA1T	29.7	-21.6	34.1	54	-19.9	-	-	9	114	H

* - indicates frequency in CFR47 Pt 15 / IC RSS-Restricted Band
 Pk - Peak detector
 VA1T - FHSS: Linear Voltage Average $V_B=1/T_{on}$ where: T_{on} is transmitting duration

VERTICAL RESULT

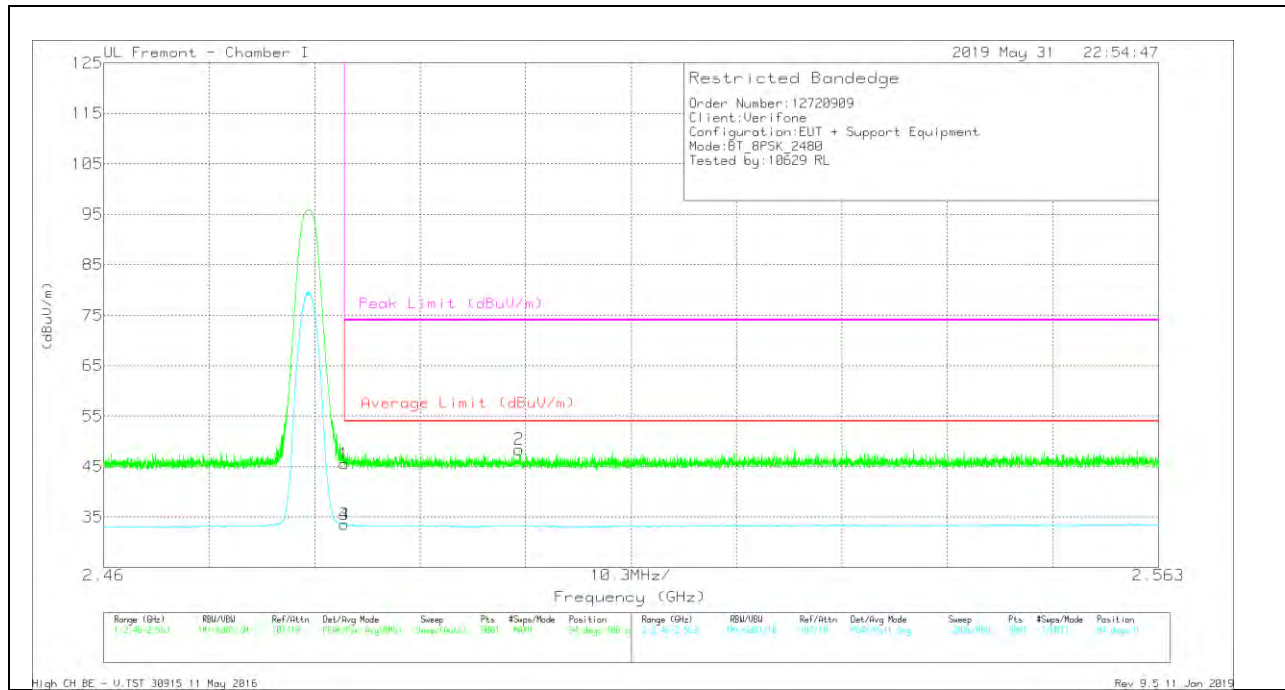

Trace Markers

Marker	Frequency (GHz)	Meter Reading (dBuV)	Det	AF PRE019081 0 (dB/m)	Amp/Cbl/Fit r/Pad (dB)	Corrected Reading (dBuV/m)	Average Limit (dBuV/m)	Margin (dB)	Peak Limit (dBuV/m)	PK Margin (dB)	Azimuth (Degs)	Height (cm)	Polarity
1	* 2.484	37.86	Pk	29.4	-21.7	45.56	-	-	74	-28.44	94	106	V
2	2.501	40.57	Pk	29.5	-21.7	48.37	-	-	74	-25.63	94	106	V
3	* 2.484	25.84	VA1T	29.4	-21.7	33.54	54	-20.46	-	-	94	106	V
4	* 2.484	25.85	VA1T	29.4	-21.7	33.55	54	-20.45	-	-	94	106	V

* - indicates frequency in CFR47 Pt 15 / IC RSS-Restricted Band

Pk - Peak detector

VA1T - FHSS: Linear Voltage Average VB=1/Ton where: Ton is transmitting duration

HARMONICS AND SPURIOUS EMISSIONS

LOW CHANNEL RESULTS

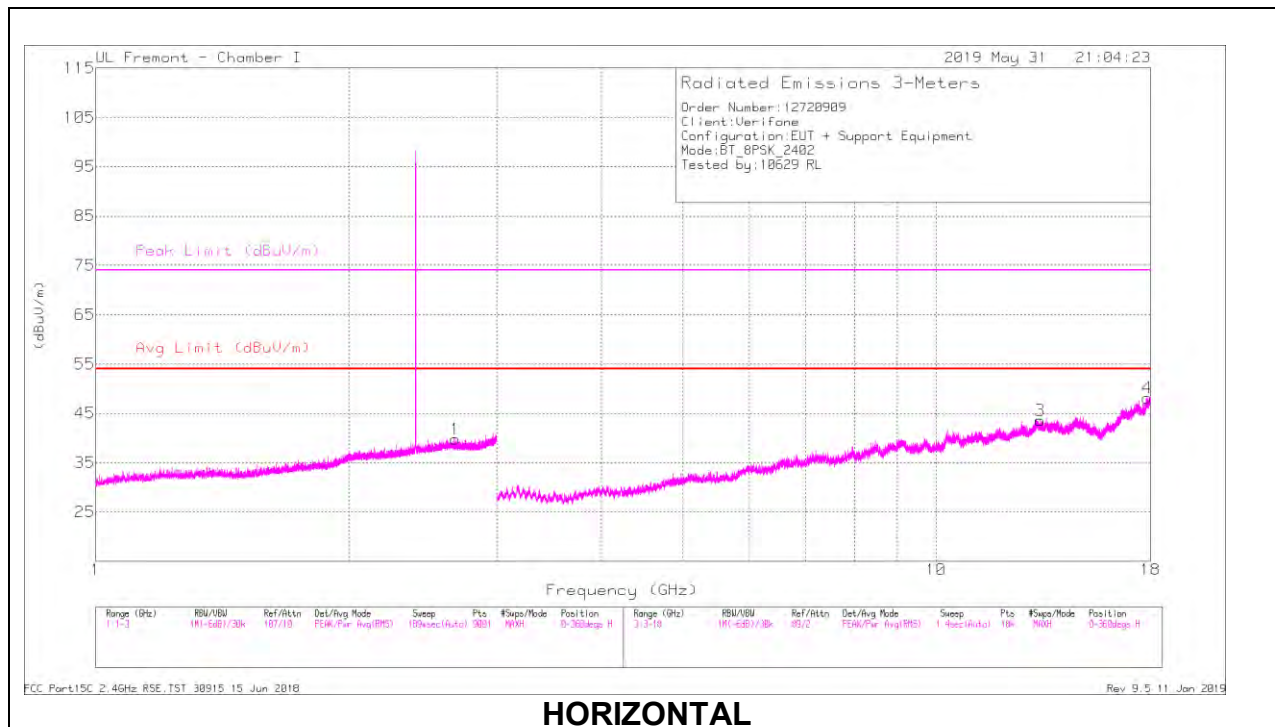

HORIZONTAL

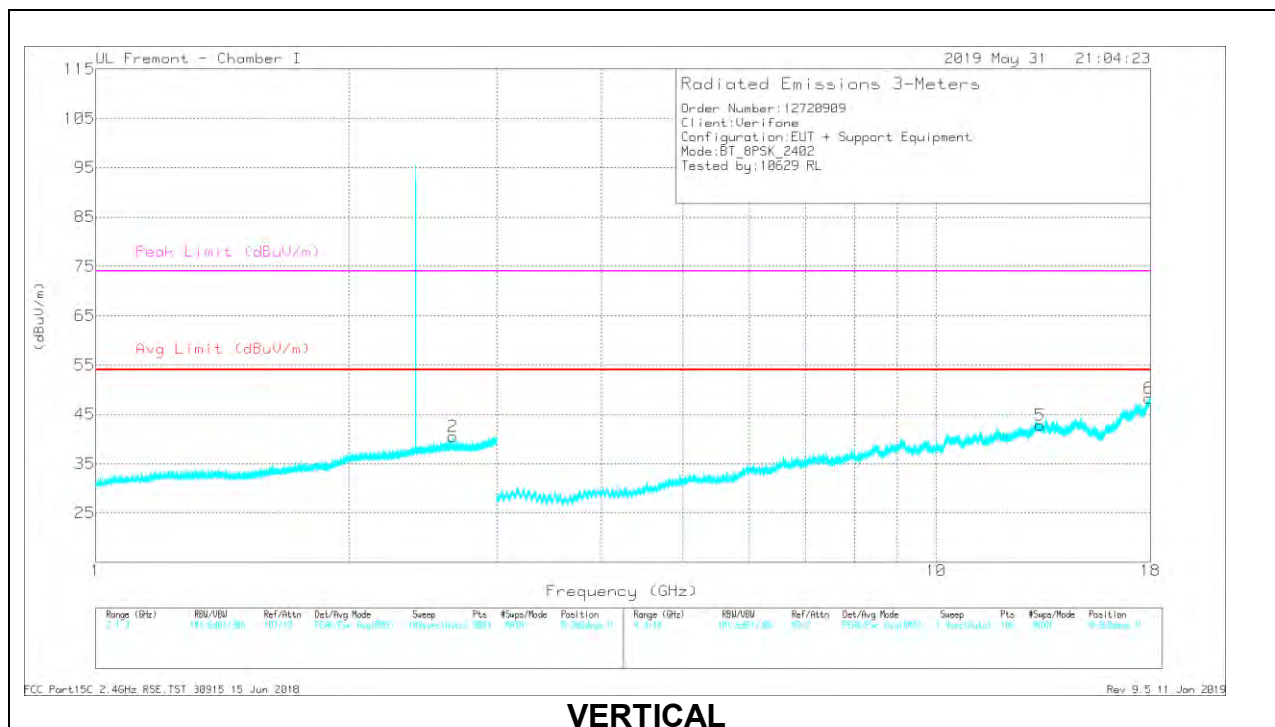

VERTICAL

RADIATED EMISSIONS

Marker	Frequency (GHz)	Meter Reading (dBuV)	Det	AF PRE0190810 (dB/m)	Amp/Cbl/Fitr/Pad (dB)	Corrected Reading (dBuV/m)	Avg Limit (dBuV/m)	Margin (dB)	Peak Limit (dBuV/m)	PK Margin (dB)	Azimuth (Degs)	Height (cm)	Polarity
1	* 2.679	38.65	PKFH	29.6	-21.2	47.05	-	-	74	-26.95	87	200	H
	* 2.679	25.72	VA1T	29.6	-21.2	34.12	54	-19.88	-	-	87	200	H
2	* 2.661	38.41	PKFH	29.6	-21.3	46.71	-	-	74	-27.29	242	108	V
	* 2.66	25.88	VA1T	29.6	-21.3	34.18	54	-19.82	-	-	242	108	V
3	* 13.313	32.75	PKFH	41.1	-21.5	52.35	-	-	74	-21.65	286	330	H
	* 13.312	18.55	VA1T	41.1	-21.5	38.15	54	-15.85	-	-	286	330	H
4	* 17.838	27.21	PKFH	42.5	-14.7	55.01	-	-	74	-18.99	265	114	H
	* 17.838	14.79	VA1T	42.5	-14.7	42.59	54	-11.41	-	-	265	114	H
5	* 13.296	31.23	PKFH	41.1	-21.5	50.83	-	-	74	-23.17	201	195	V
	* 13.296	18.58	VA1T	41.1	-21.5	38.18	54	-15.82	-	-	201	195	V
6	* 17.941	28.1	PKFH	43.1	-15.5	55.7	-	-	74	-18.3	236	348	V
	* 17.938	15.48	VA1T	43.1	-15.4	43.18	54	-10.82	-	-	236	348	V

* - indicates frequency in CFR47 Pt 15 / IC RSS-Restricted Band
 PKFH FHSS/BT RB=100k for Frequencies<1GHz / RB=1MHz for Frequencies>1GHz, VB=3 x RB, Peak
 VA1T - FHSS: Linear Voltage Average VB=1/T on where: Ton is transmitting duration

MID CHANNEL RESULTS

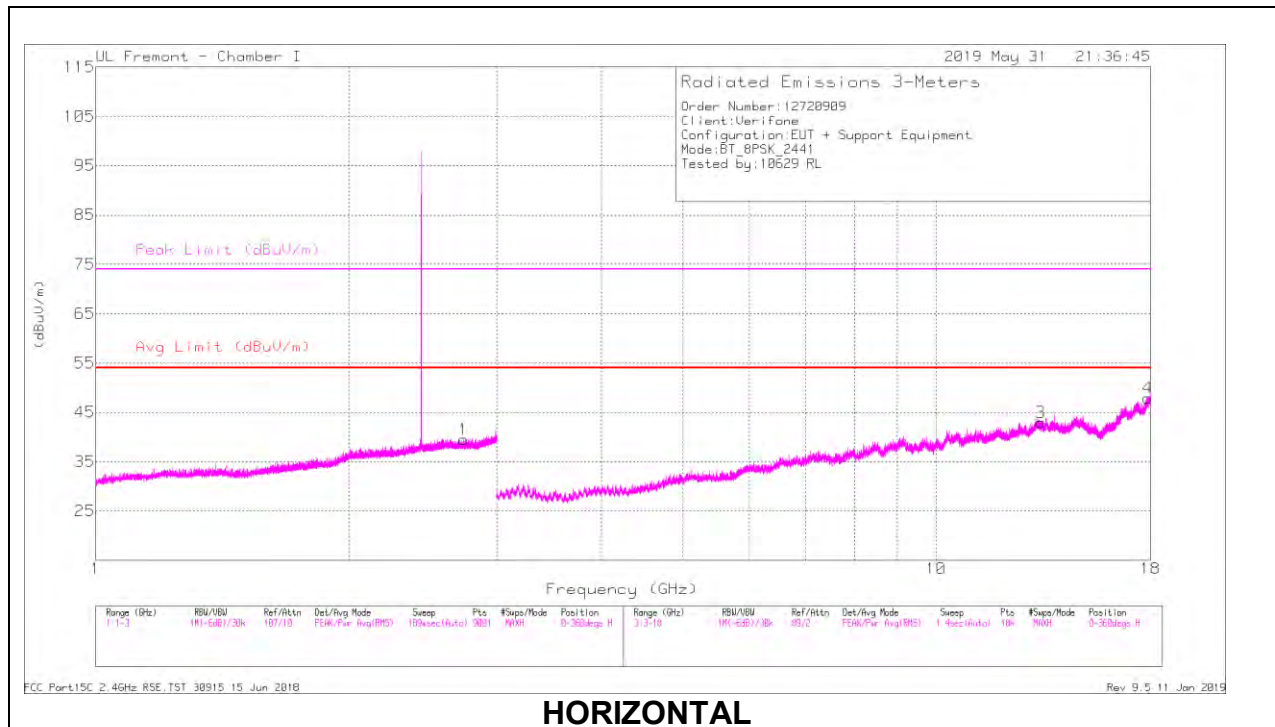

HORIZONTAL

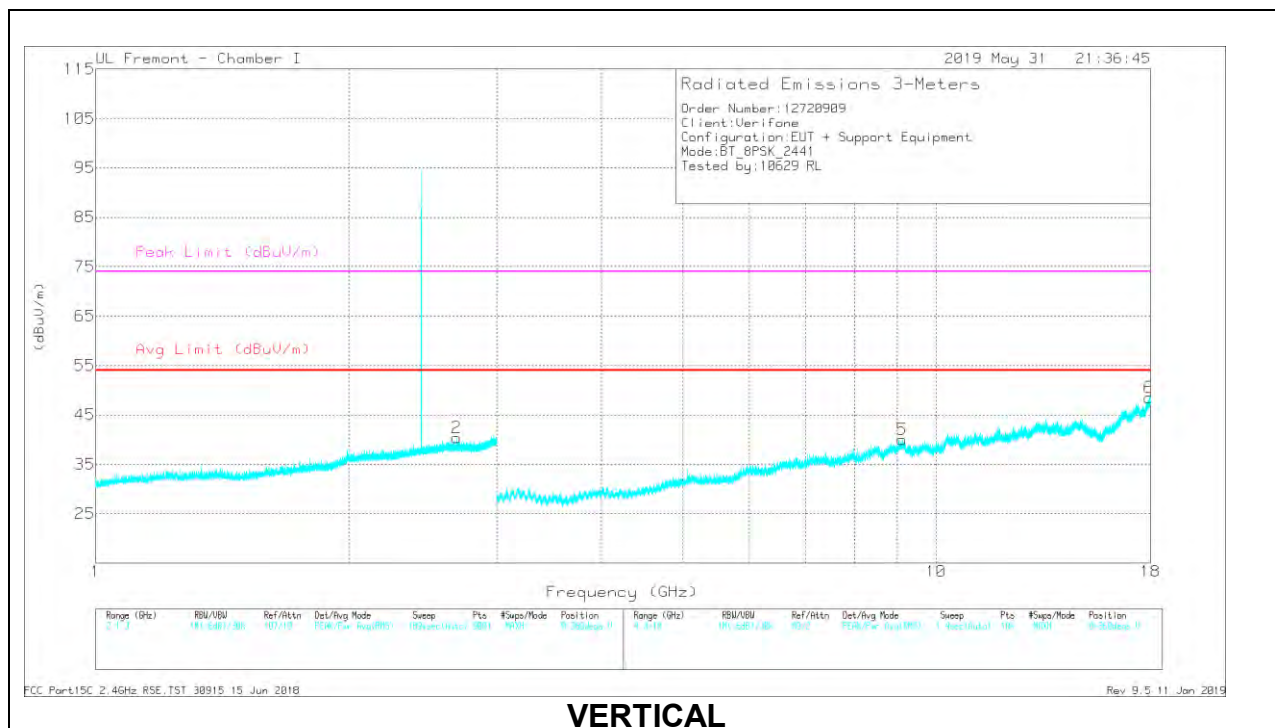

VERTICAL

RADIATED EMISSIONS

Marker	Frequency (GHz)	Meter Reading (dBuV)	Det	AF PRE0190810 (dB/m)	Amp/Cbl/Fitr/Pad (dB)	Corrected Reading (dBuV/m)	Avg Limit (dBuV/m)	Margin (dB)	Peak Limit (dBuV/m)	PK Margin (dB)	Azimuth (Degs)	Height (cm)	Polarity
1	* 2.739	38.08	PKFH	29.4	-21	46.48	-	-	74	-27.52	197	112	H
	* 2.738	25.63	VA1T	29.4	-21	34.03	54	-19.97	-	-	197	112	H
2	* 2.686	38.69	PKFH	29.5	-21.2	46.99	-	-	74	-27.01	246	303	V
	* 2.69	25.79	VA1T	29.5	-21.2	34.09	54	-19.91	-	-	246	303	V
3	* 13.316	31.31	PKFH	41.1	-21.5	50.91	-	-	74	-23.09	350	160	H
	* 13.318	18.78	VA1T	41.1	-21.5	38.38	54	-15.62	-	-	350	160	H
4	* 17.868	27.12	PKFH	42.7	-14.7	55.12	-	-	74	-18.88	148	275	H
	* 17.869	14.82	VA1T	42.7	-14.7	42.82	54	-11.18	-	-	148	275	H
5	* 9.114	30.61	PKFH	37.9	-21.3	47.21	-	-	74	-26.79	125	191	V
	* 9.116	18.16	VA1T	37.9	-21.3	34.76	54	-19.24	-	-	125	191	V
6	* 17.931	27.42	PKFH	43.1	-15.4	55.12	-	-	74	-18.88	225	203	V
	* 17.931	15.26	VA1T	43.1	-15.4	42.96	54	-11.04	-	-	225	203	V

* - indicates frequency in CFR47 Pt 15 / IC RSS-Restricted Band
 PKFH FHSS/BT RB=100k for Frequencies<1GHz / RB=1MHz for Frequencies>1GHz, VB=3 x RB, Peak
 VA1T - FHSS: Linear Voltage Average VB=1/T on where: Ton is transmitting duration

HIGH CHANNEL RESULTS

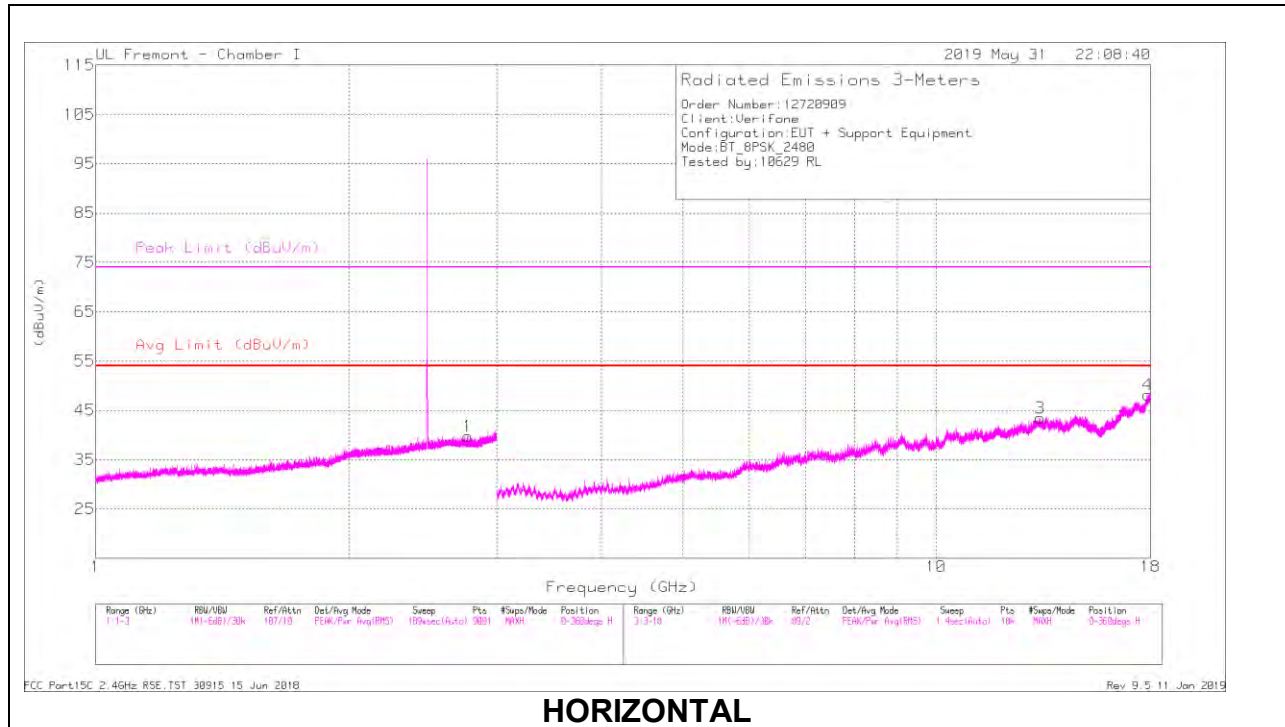

HORIZONTAL

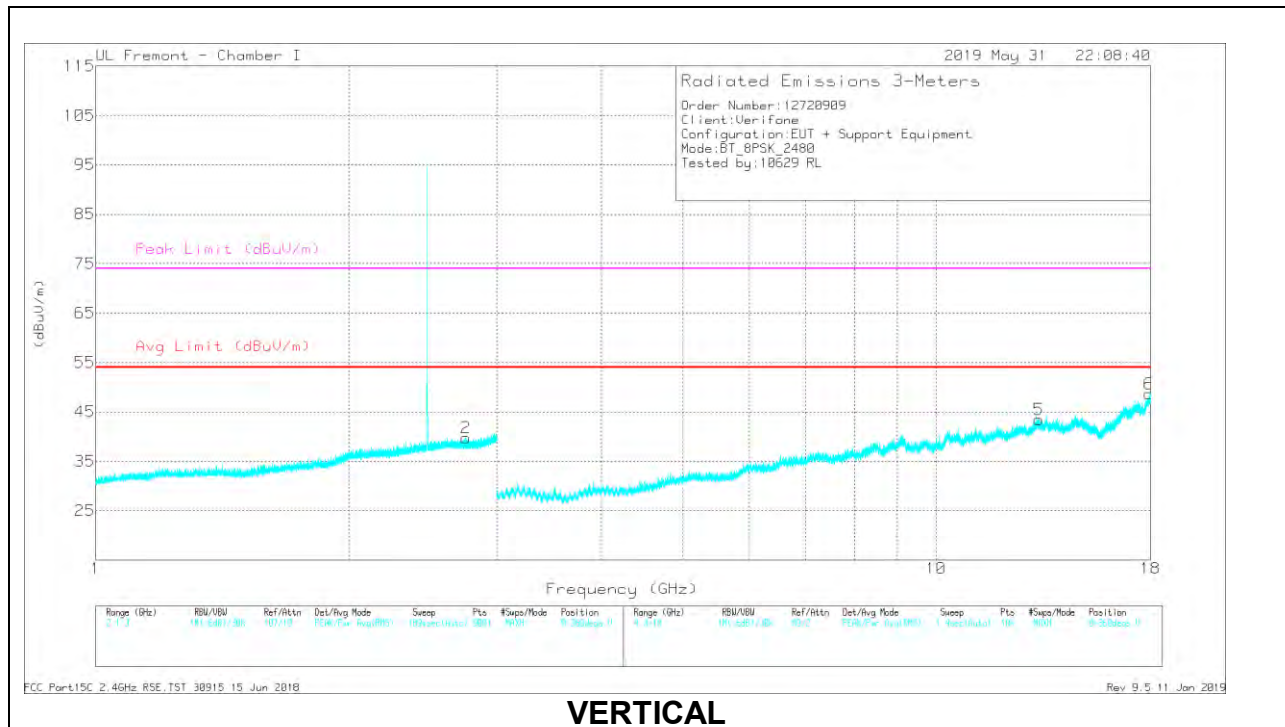

VERTICAL

RADIATED EMISSIONS

Marker	Frequency (GHz)	Meter Reading (dBuV)	Det	AF PRE0190810 (dB/m)	Amp/Cbl/Fitr/Pad (dB)	Corrected Reading (dBuV/m)	Avg Limit (dBuV/m)	Margin (dB)	Peak Limit (dBuV/m)	PK Margin (dB)	Azimuth (Degs)	Height (cm)	Polarity
1	* 2.774	39.6	PKFH	29.3	-20.9	48	-	-	74	-26	126	138	H
	* 2.774	25.65	VA1T	29.3	-20.9	34.05	54	-19.95	-	-	126	138	H
2	* 2.762	38.26	PKFH	29.3	-20.9	46.66	-	-	74	-27.34	328	172	V
	* 2.763	25.75	VA1T	29.3	-20.9	34.15	54	-19.85	-	-	328	172	V
3	*13.309	30.66	PKFH	41.1	-21.5	50.26	-	-	74	-23.74	223	125	H
	*13.309	18.67	VA1T	41.1	-21.4	38.37	54	-15.63	-	-	223	125	H
4	*17.883	27.55	PKFH	42.8	-15.1	55.25	-	-	74	-18.75	4	244	H
	*17.881	14.94	VA1T	42.8	-15	42.74	54	-11.26	-	-	4	244	H
5	*13.261	30.49	PKFH	41.1	-21.4	50.19	-	-	74	-23.81	225	342	V
	*13.262	18.48	VA1T	41.1	-21.4	38.18	54	-15.82	-	-	225	342	V
6	*17.928	27.56	PKFH	43.1	-15.4	55.26	-	-	74	-18.74	210	329	V
	*17.927	15.4	VA1T	43.1	-15.4	43.1	54	-10.9	-	-	210	329	V

* - indicates frequency in CFR47 Pt 15 / IC RSS-Restricted Band
 PKFH FHSS/BT RB=100k for Frequencies<1GHz / RB=1MHz for Frequencies>1GHz, VB=3 x RB, Peak
 VA1T - FHSS: Linear Voltage Average VB=1/T on where: Ton is transmitting duration

9.2. WORST CASE BELOW 30MHZ

SPURIOUS EMISSIONS BELOW 30 MHz (WORST-CASE CONFIGURATION)

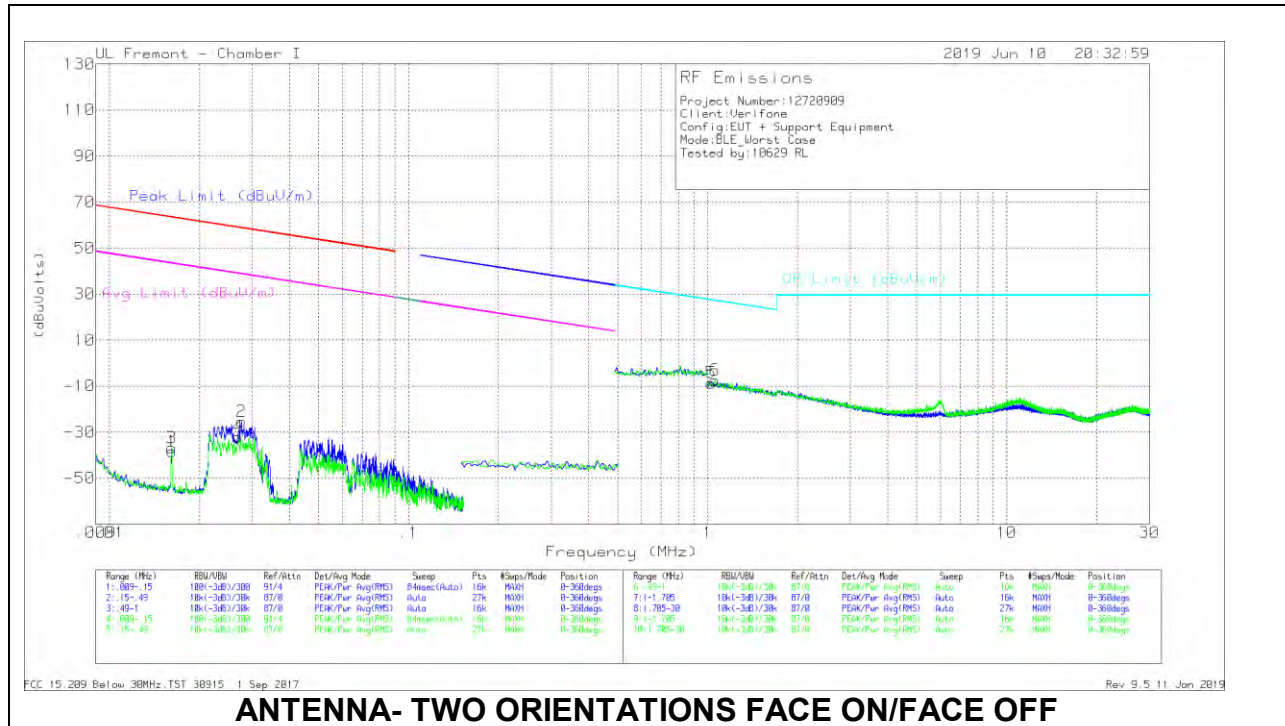

Below 30MHz Data

Marker	Frequency (MHz)	Meter Reading (dBuV)	Det	Loop Antenna (ACF)	Cables w/ PRE0180175 (dB)	Dist Corr 300m	Corrected Reading (dBuVolts)	Peak Limit (dBuV/m)	Margin (dB)	Avg Limit (dBuV/m)	Margin (dB)	QP Limit (dBuV/m)	Margin (dB)	Azimuth (Degs)
1	.01616	14.72	Pk	59.3	-32.4	-80	-38.38	63.42	-101.8	43.42	-81.8	-	-	0-360
2	.02763	29.07	Pk	58	-32.3	-80	-25.23	58.76	-83.99	38.76	-63.99	-	-	0-360
3	.01616	16.25	Pk	59.3	-32.4	-80	-36.85	63.42	-100.27	43.42	-80.27	-	-	0-360
4	.02699	22.17	Pk	58	-32.3	-80	-32.13	58.96	-91.09	38.96	-71.09	-	-	0-360

Pk - Peak detector

Marker	Frequency (MHz)	Meter Reading (dBuV)	Det	Loop Antenna (ACF)	Cables w/ PRE0180175 (dB)	Dist Corr 30m (dB) 40Log	Corrected Reading (dBuVolts)	Peak Limit (dBuV/m)	Margin (dB)	Avg Limit (dBuV/m)	Margin (dB)	QP Limit (dBuV/m)	Margin (dB)	Azimuth (Degs)
5	1.02968	16.62	Pk	46.6	-31.8	-40	-8.58	-	-	-	-	27.37	-35.95	0-360
6	1.05826	17.82	Pk	46.5	-31.8	-40	-7.48	-	-	-	-	27.13	-34.61	0-360

Pk - Peak detector

9.3. WORST CASE BELOW 1 GHZ

SPURIOUS EMISSIONS 30 TO 1000 MHz (WORST-CASE CONFIGURATION)

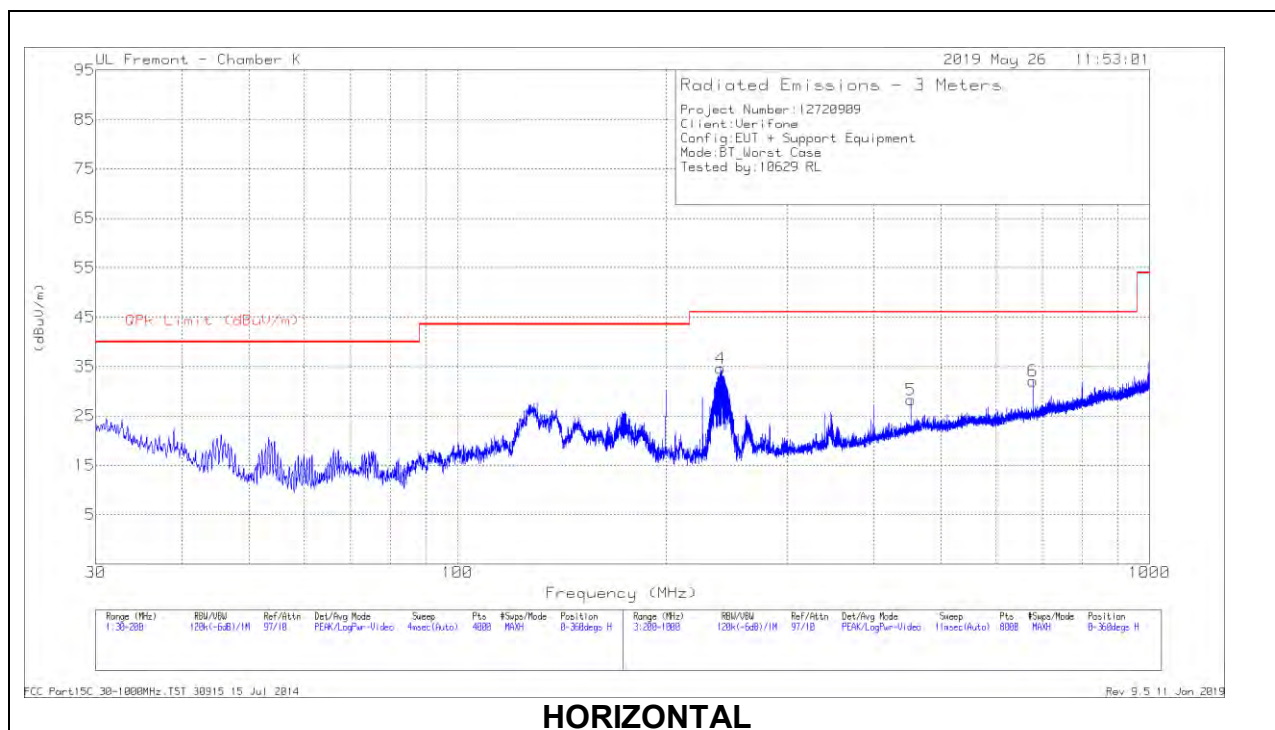

HORIZONTAL

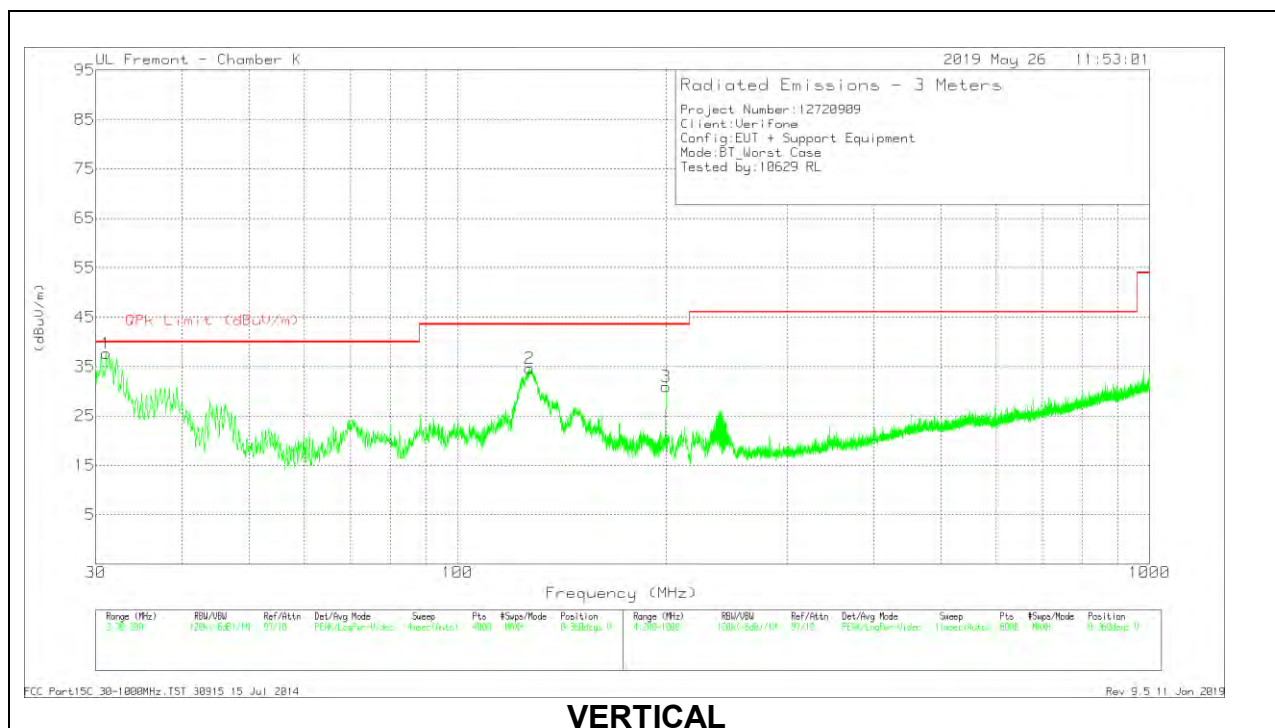

VERTICAL

Below 1GHz Data

Marker	Frequency (MHz)	Meter Reading (dBuV)	Det	AF PRE0184052 (dB/m)	Amp/Cbl (dB)	Corrected Reading (dBuV/m)	QPk Limit (dBuV/m)	Margin (dB)	Azimuth (Degs)	Height (cm)	Polarity
1	30.5338	44.45	Pk	26.1	-31.6	38.95	40	-1.05	6	100	V
	30.5338	38.59	Qp	26.1	-31.6	33.09	40	-6.91	6	100	V
2	* 126.6579	45.04	Pk	19.6	-30.7	33.94	43.52	-9.58	3	106	V
	* 126.6579	41.81	Qp	19.6	-30.7	30.71	43.52	-12.81	3	106	V
3	199.9908	42.04	Pk	18.5	-30.3	30.24	43.52	-13.28	124	155	V
	199.9908	31.35	Qp	18.5	-30.3	19.55	43.52	-23.97	124	155	V
4	239.9993	48.89	Pk	17.5	-30	36.39	46.02	-9.63	92	121	H
	239.9993	46.46	Qp	17.5	-30	33.96	46.02	-12.06	92	121	H
5	452.1645	35.58	Pk	22.8	-29.1	29.28	46.02	-16.74	83	223	H
	452.1645	33.02	Qp	22.8	-29.1	26.72	46.02	-19.3	83	223	H
6	678.2478	39.29	Pk	25.7	-28.4	36.59	46.02	-9.43	258	125	H
	678.2478	37.93	Qp	25.7	-28.4	35.23	46.02	-10.79	258	125	H

* - indicates frequency in CFR47 Pt 15 / IC RSS-Restricted Band

Pk - Peak detector

Qp - Quasi-Peak detector

9.4. WORST CASE 18-26 GHZ

SPURIOUS EMISSIONS 18-26 GHz (WORST-CASE CONFIGURATION)

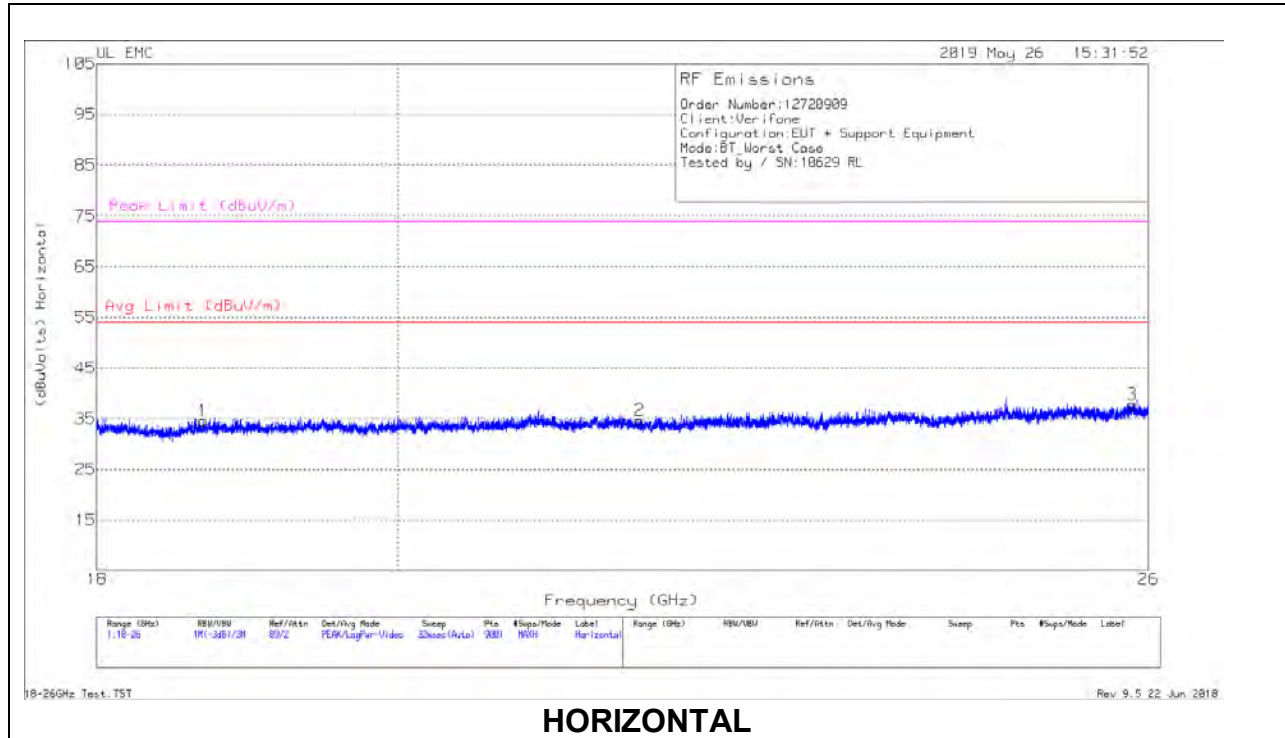

HORIZONTAL

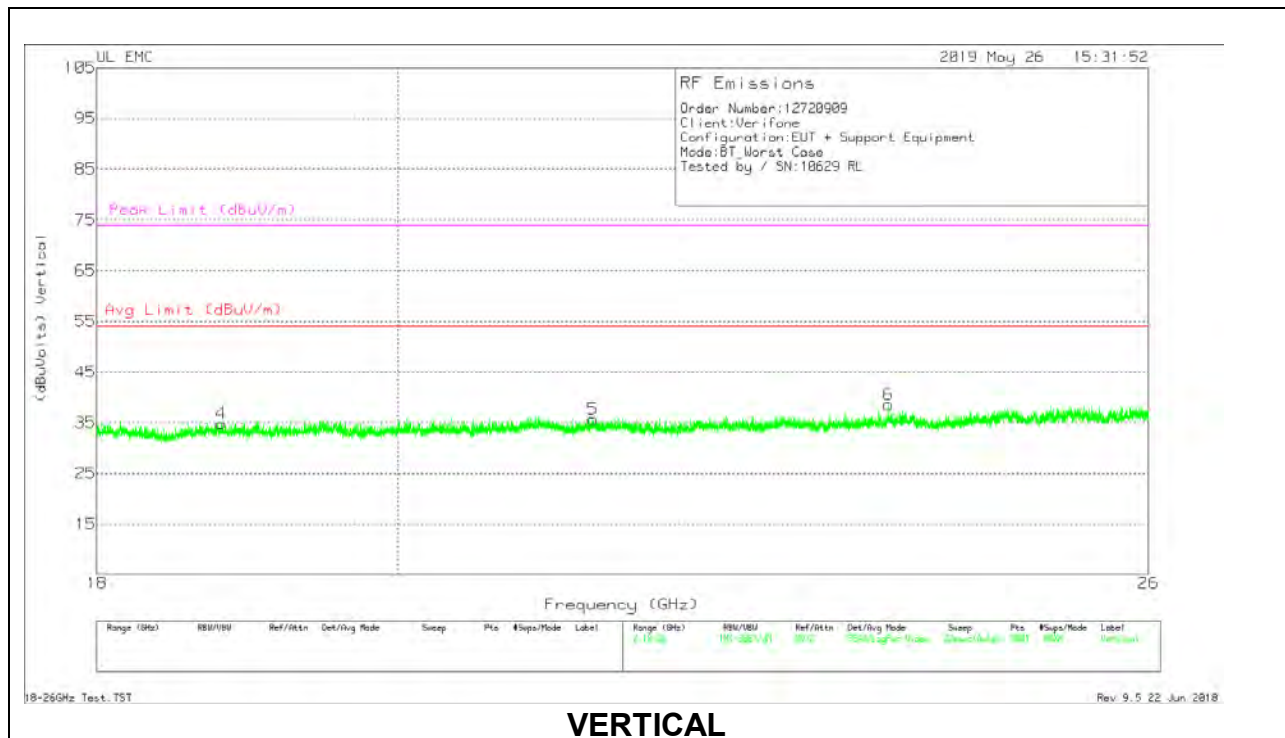

VERTICAL

18 – 26GHz DATA

Marker	Frequency (GHz)	Meter Reading (dBuV)	Det	AF PRE0182188 (dB/m)	Amp/Cbl (dB)	Dist Corr (dB)	Corrected Reading (dBuVolts)	Avg Limit (dBuV/m)	Margin (dB)	Peak Limit (dBuV/m)	PK Margin (dB)
1	18.881	69.72	Pk	33.1	-58.7	-9.5	34.62	54	-19.38	74	-39.38
2	21.763	67.77	Pk	33.9	-57.5	-9.5	34.67	54	-19.33	74	-39.33
3	25.853	67.5	Pk	35.1	-55.3	-9.5	37.8	54	-16.2	74	-36.2
4	18.8	69.42	Pk	33.2	-58.3	-9.5	34.82	54	-19.18	74	-39.18
5	21.409	68.38	Pk	33.7	-56.9	-9.5	35.68	54	-18.32	74	-38.32
6	23.74	70.42	Pk	34.5	-56.8	-9.5	38.62	54	-15.38	74	-35.38

Pk - Peak detector

10. AC POWER LINE CONDUCTED EMISSIONS

LIMITS

FCC §15.207 (a)

RSS-Gen 8.8

Frequency of Emission (MHz)	Conducted Limit (dBuV)	
	Quasi-peak	Average
0.15-0.5	66 to 56 [*]	56 to 46 [*]
0.5-5	56	46
5-30	60	50

^{*}Decreases with the logarithm of the frequency.

TEST PROCEDURE

The EUT is placed on a non-conducting table 40 cm from the vertical ground plane and 80 cm above the horizontal ground plane. The EUT is configured in accordance with ANSI C63.4.

The receiver is set to a resolution bandwidth of 9 kHz. Peak detection is used unless otherwise noted as quasi-peak or average.

Line conducted data is recorded for both NEUTRAL and HOT lines.

RESULTS

10.1.1. AC Power Line Norm

LINE 1 RESULTS

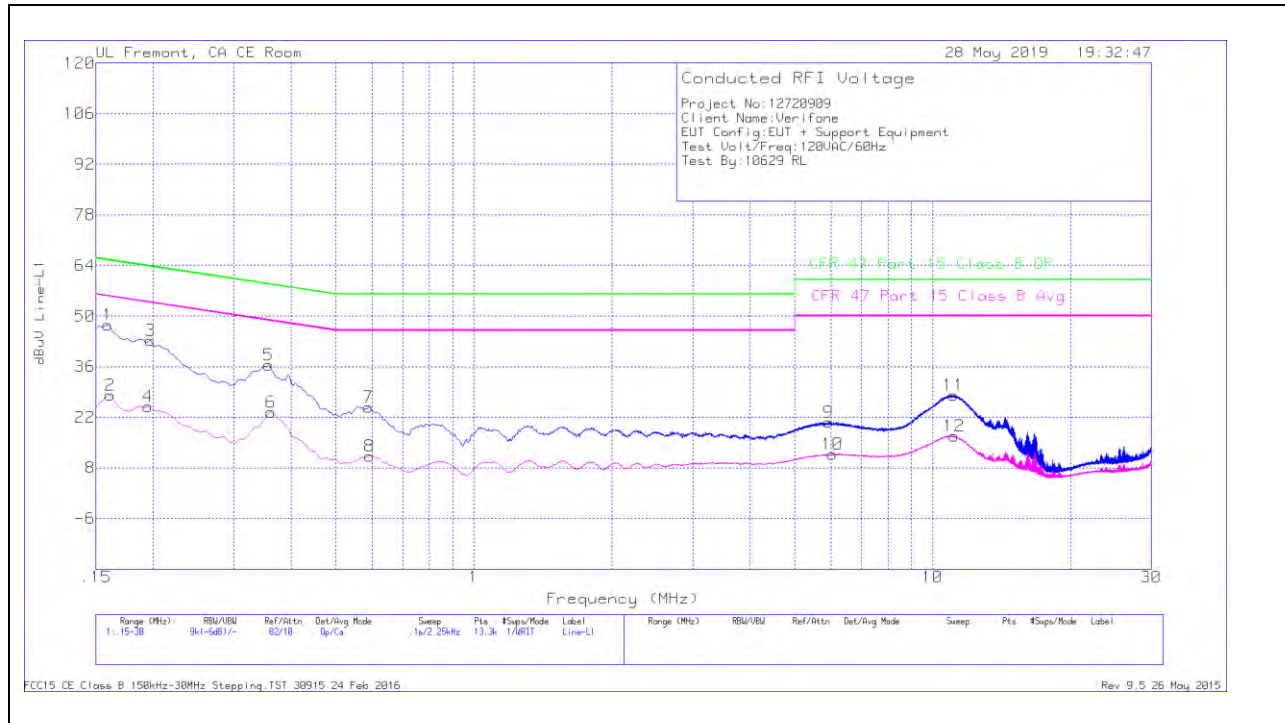

Trace Markers

Range 1: Line-L1 .15 - 30MHz											
Marker	Frequency (MHz)	Meter Reading (dBuV)	Det	LISN L1	LC Cables C1&C3	Limiter (dB)	Corrected Reading dBuV	CFR 47 Part 15 Class B QP	QP Margin (dB)	CFR 47 Part 15 Class B Avg	Av(CISPR) Margin (dB)
1	.159	37.32	Qp	.1	0	10.1	47.52	65.52	-18	-	-
2	.16125	17.83	Ca	.1	0	10.1	28.03	-	-	55.4	-27.37
3	.19725	33.09	Qp	0	0	10.1	43.19	63.73	-20.54	-	-
4	.195	14.91	Ca	0	0	10.1	25.01	-	-	53.82	-28.81
5	.357	26.27	Qp	0	0	10.1	36.37	58.8	-22.43	-	-
6	.3615	13.3	Ca	0	0	10.1	23.4	-	-	48.69	-25.29
7	.58875	14.77	Qp	0	0	10.1	24.87	56	-31.13	-	-
8	.59325	1.21	Ca	0	0	10.1	11.31	-	-	46	-34.69
9	5.9325	10.24	Qp	0	.2	10.2	20.64	60	-39.36	-	-
10	6.05175	1.35	Ca	0	.2	10.2	11.75	-	-	50	-38.25
11	11.10075	17.66	Qp	.1	.2	10.2	28.16	60	-31.84	-	-
12	11.13675	6.37	Ca	.1	.2	10.2	16.87	-	-	50	-33.13

Qp - Quasi-Peak detector

Ca - CISPR average detection

LINE 2 RESULTS

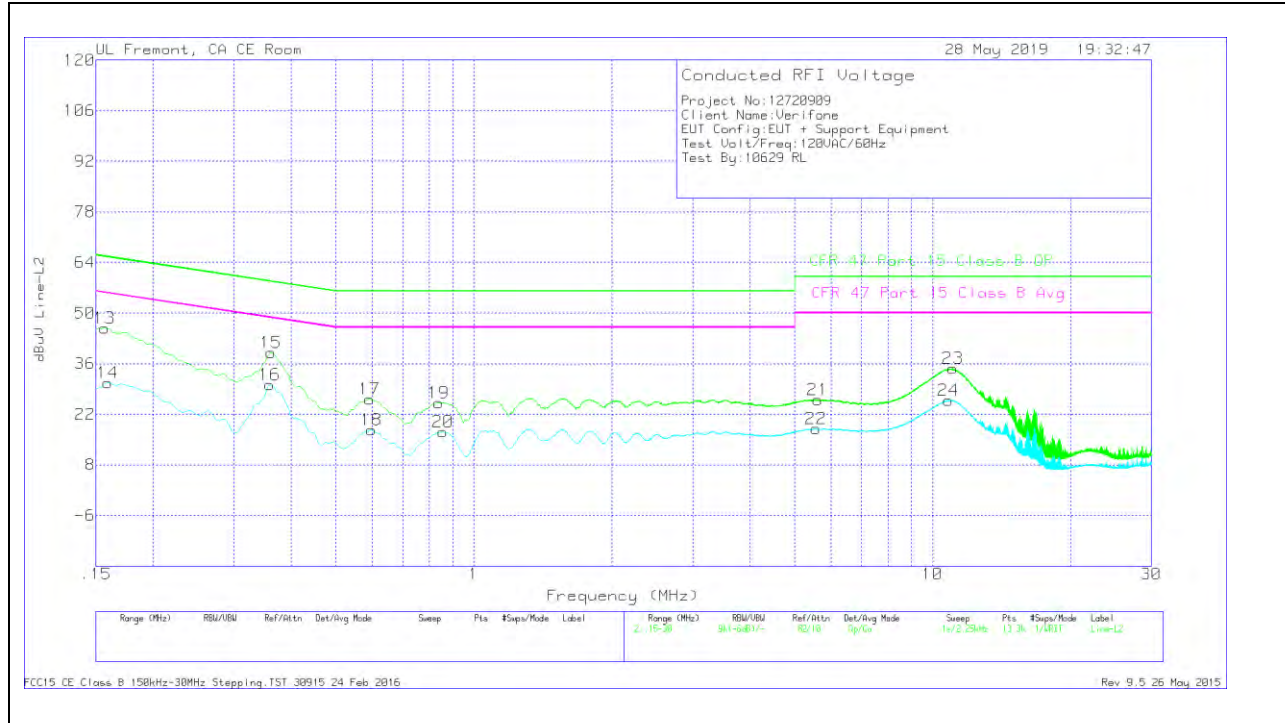

Trace Markers

Range 2: Line-L2 .15 - 30MHz											
Marker	Frequency (MHz)	Meter Reading (dBuV)	Det	LISN L2	LC Cables C2&C3	Limiter (dB)	Corrected Reading dBuV	CFR 47 Part 15 Class B QP	QP Margin (dB)	CFR 47 Part 15 Class B Avg	Av(CISPR) Margin (dB)
13	.15675	35.68	Qp	.1	0	10.1	45.88	65.63	-19.75	-	-
14	.159	20.52	Ca	.1	0	10.1	30.72	-	-	55.52	-24.8
15	.3615	28.89	Qp	0	0	10.1	38.99	58.69	-19.7	-	-
16	.35925	20.01	Ca	0	0	10.1	30.11	-	-	48.75	-18.64
17	.59325	16.04	Qp	0	0	10.1	26.14	56	-29.86	-	-
18	.59887	7.57	Ca	0	0	10.1	17.67	-	-	46	-28.33
19	.8385	15.09	Qp	0	0	10.1	25.19	56	-30.81	-	-
20	.8565	7.03	Ca	0	0	10.1	17.13	-	-	46	-28.87
21	5.6175	15.69	Qp	0	.2	10.2	26.09	60	-33.91	-	-
22	5.57025	7.72	Ca	0	.2	10.1	18.02	-	-	50	-31.98
23	11.067	24.23	Qp	.1	.2	10.2	34.73	60	-25.27	-	-
24	10.83188	15.45	Ca	0	.2	10.2	25.85	-	-	50	-24.15

Qp - Quasi-Peak detector
 Ca - CISPR average detection