

TEST REPORT

CERTIFICATE OF CONFORMITY

Standard: 47 CFR FCC Part 15, Subpart C (Section 15.247)

Report No.: RFBCUG-WTW-P23030303

FCC ID: B32M4250

Product: Point of Sale Terminal

Brand: Verifone

Model No.: M425-1

Received Date: 2023/3/9

Test Date: 2023/4/11 ~ 2023/4/25

Issued Date: 2023/5/8

Applicant: Verifone, Inc.

Address: 1400 West Stanford Ranch Road Suite 150 Rocklin CA 95765 USA

Issued By: Bureau Veritas Consumer Products Services (H.K.) Ltd., Taoyuan Branch
Lin Kou Laboratories

Lab Address: No. 47-2, 14th Ling, Chia Pau Vil., Lin Kou Dist., New Taipei City, Taiwan

Test Location(1): No. 19, Hwa Ya 2nd Rd., Wen Hwa Vil., Kewi Shan Dist., Taoyuan City 33383, Taiwan

Test Location (2): B2F., No.215, Sec. 3, Beixin Rd., Xindian Dist., New Taipei City 231, Taiwan

FCC Registration / 788550 / TW0003

Designation Number: 427177 / TW0011

Approved by: _____

Jeremy Lin

Date: _____

2023/5/8

Jeremy Lin / Project Engineer

This test report consists of 28 pages in total. It may be duplicated completely for legal use with the approval of the applicant. It should not be reproduced except in full, without the written approval of our laboratory. The test results in the report only apply to the tested sample. The test results in this report are traceable to the national or international standards.



Prepared by : Gina Liu / Specialist

This report is governed by, and incorporates by reference, the Conditions of Testing as posted at the date of issuance of this report at <http://www.bureauveritas.com/home/about-us/our-business/cps/about-us/terms-conditions/> and is intended for your exclusive use. Any copying or replication of this report to or for any other person or entity, or use of our name or trademark, is permitted only with our prior written permission. This report sets forth our findings solely with respect to the test samples identified herein. The results set forth in this report are not indicative or representative of the quality or characteristics of the lot from which a test sample was taken or any similar or identical product unless specifically and expressly noted. Our report includes all of the tests requested by you and the results thereof based upon the information that you provided to us. Measurement uncertainty is only provided upon request for accredited tests. Statements of conformity are based on simple acceptance criteria without taking measurement uncertainty into account, unless otherwise requested in writing. You have 60 days from date of issuance of this report to notify us of any material error or omission caused by our negligence or if you require measurement uncertainty; provided, however, that such notice shall be in writing and shall specifically address the issue you wish to raise. A failure to raise such issue within the prescribed time shall constitute your unqualified acceptance of the completeness of this report, the tests conducted and the correctness of the report contents.

Table of Contents

| | |
|---|-----------|
| Release Control Record | 3 |
| 1 Certificate..... | 4 |
| 2 Summary of Test Results | 5 |
| 2.1 Measurement Uncertainty | 5 |
| 2.2 Supplementary Information | 5 |
| 3 General Information | 6 |
| 3.1 General Description | 6 |
| 3.2 Antenna Description of EUT | 7 |
| 3.3 Channel List..... | 7 |
| 3.4 Test Mode Applicability and Tested Channel Detail..... | 7 |
| 3.5 Duty Cycle of Test Signal..... | 8 |
| 3.6 Test Program Used and Operation Descriptions | 8 |
| 3.7 Connection Diagram of EUT and Peripheral Devices | 9 |
| 3.8 Configuration of Peripheral Devices and Cable Connections | 9 |
| 4 Test Instruments | 10 |
| 4.1 RF Output Power..... | 10 |
| 4.2 AC Power Conducted Emissions | 10 |
| 4.3 Unwanted Emissions below 1 GHz | 11 |
| 4.4 Unwanted Emissions above 1 GHz..... | 12 |
| 5 Limits of Test Items..... | 13 |
| 5.1 RF Output Power..... | 13 |
| 5.2 AC Power Conducted Emissions | 13 |
| 5.3 Unwanted Emissions below 1 GHz | 13 |
| 5.4 Unwanted Emissions above 1 GHz..... | 13 |
| 6 Test Arrangements..... | 14 |
| 6.1 RF Output Power..... | 14 |
| 6.1.1 Test Setup | 14 |
| 6.1.2 Test Procedure..... | 14 |
| 6.2 AC Power Conducted Emissions | 14 |
| 6.2.1 Test Setup | 14 |
| 6.2.2 Test Procedure..... | 14 |
| 6.3 Unwanted Emissions below 1 GHz | 15 |
| 6.3.1 Test Setup | 15 |
| 6.3.2 Test Procedure..... | 16 |
| 6.4 Unwanted Emissions above 1 GHz..... | 17 |
| 6.4.1 Test Setup | 17 |
| 6.4.2 Test Procedure..... | 17 |
| 7 Test Results of Test Item | 18 |
| 7.1 RF Output Power..... | 18 |
| 7.2 AC Power Conducted Emissions | 20 |
| 7.3 Unwanted Emissions below 1 GHz | 22 |
| 7.4 Unwanted Emissions above 1 GHz..... | 24 |
| 8 Pictures of Test Arrangements | 27 |
| 9 Information of the Testing Laboratories | 28 |



Release Control Record

| Issue No. | Description | Date Issued |
|----------------------|-------------------|-------------|
| RFBCUG-WTW-P23030303 | Original release. | 2023/5/8 |

1 Certificate

Product: Point of Sale Terminal

Brand: Verifone

Test Model: M425-1

Sample Status: Engineering sample

Applicant: Verifone, Inc.

Test Date: 2023/4/11 ~ 2023/4/25

Standard: 47 CFR FCC Part 15, Subpart C (Section 15.247)

Measurement ANSI C63.10-2013

procedure: KDB 558074 D01 15.247 Meas Guidance v05r02

The above equipment has been tested by **Bureau Veritas Consumer Products Services (H.K.) Ltd., Taoyuan Branch**, and found compliance with the requirement of the above standards. The test record, data evaluation & Equipment Under Test (EUT) configurations represented herein are true and accurate accounts of the measurements of the sample's RF characteristics under the conditions specified in this report.

2 Summary of Test Results

| 47 CFR FCC Part 15, Subpart C (Section 15.247) | | | |
|--|---------------------------------|--------|---|
| Standard / Clause | Test Item | Result | Remark |
| 15.247(b) | RF Output Power | Pass | Meet the requirement of limit. |
| 15.247(e) | Power Spectral Density | NA | Refer to note |
| 15.247(a)(2) | 6 dB Bandwidth | NA | Refer to note |
| 15.247(d) | Conducted Out of Band Emissions | NA | Refer to note |
| 15.207 | AC Power Conducted Emissions | Pass | Minimum passing margin is -18.31 dB at 0.39000 MHz |
| 15.205 / 15.209 / 15.247(d) | Unwanted Emissions below 1 GHz | Pass | Minimum passing margin is -4.4 dB at 34.15 MHz |
| 15.205 / 15.209 / 15.247(d) | Unwanted Emissions above 1 GHz | Pass | Minimum passing margin is -2.0 dB at 2390.00, 2483.50 MHz |
| 15.203 | Antenna Requirement | Pass | Antenna connector is ipex not a standard connector. |

Note:

1. This report is a supplementary report. Therefore, only Output Power, AC Power Conducted Emissions and Radiated Emissions were verified and recored in this report. Other testing data please refer to the original BV CPS report no.: RFBCUG-WTW-P23030304.
2. Determining compliance based on the results of the compliance measurement, not taking into account measurement instrumentation uncertainty.

2.1 Measurement Uncertainty

Where relevant, the following measurement uncertainty levels have been estimated for tests performed on the EUT as specified in CISPR 16-4-2:

| Measurement | Specification | Expanded Uncertainty (k=2) (±) |
|--------------------------------|-----------------|-----------------------------------|
| AC Power Conducted Emissions | 9 kHz ~ 30 MHz | 2.79 dB |
| Unwanted Emissions below 1 GHz | 9 kHz ~ 30 MHz | 2.44 dB |
| | 30 MHz ~ 1 GHz | 2.02 dB |
| Unwanted Emissions above 1 GHz | 1 GHz ~ 18 GHz | 1.01 dB |
| | 18 GHz ~ 40 GHz | 1.15 dB |

The other instruments specified are routine verified to remain within the calibrated levels, no measurement uncertainty is required to be calculated.

2.2 Supplementary Information

There is not any deviation from the test standards for the test method, and no modifications required for compliance.

3 General Information

3.1 General Description

| | |
|-----------------------|--|
| Product | Point of Sale Terminal |
| Brand | Verifone |
| Test Model | M425-1 |
| Status of EUT | Engineering sample |
| Power Supply Rating | 12 Vdc |
| Modulation Type | CCK, DQPSK, DBPSK for DSSS 64QAM, 16QAM, QPSK, BPSK for OFDM |
| Modulation Technology | DSSS, OFDM |
| Transfer Rate | 802.11b: 11/5.5/2/1Mbps 802.11g: 54/48/36/24/18/12/9/6Mbps 802.11n: up to 72.2Mbps |
| Operating Frequency | 2.412 GHz ~ 2.462 GHz |
| Number of Channel | 802.11b, 802.11g, 802.11n (HT20):11 |
| Output Power | 137.721 mW (21.39 dBm) |

Note:

1. This report is issued as a supplementary report to BV CPS report no. RFBCUG-WTW-P23030304. The difference compared with original report is changing model name (M450-1 change to M425-1 (the model difference refer to note 2)), therefore the EUT is verified on the worst case of the original report.
2. The model difference as below.

| Brand | Model | Difference |
|----------|--------|--|
| Verifone | M450-1 | A. Model M425-1 and M450-1 are identical, except for enclosure shape, panel size and NFC antenna- Use same main board, WiFi-BT module, antenna of WiFi-BT and NFC chip IC. |
| | M425-1 | B. TX setup power different by software, the NFC power of M450-1 will be larger than that of M425-1 NFC Power. |

3. The accessory devices of EUT, please refer to external photo.
4. There are Bluetooth and WLAN (2.4 GHz & 5 GHz) technology used for the EUT. WLAN (2.4 GHz & 5 GHz) and Bluetooth technology cannot transmit at the same time, but use time slot technology to transmit at the same time.
5. The above EUT information is declared by manufacturer and for more detailed features description, please refer to the manufacturer's specifications or User's Manual.

3.2 Antenna Description of EUT

1. The antenna information is listed as below.

| Antenna No. | Gain (dBi) | | | Antenna Type | Connector Type |
|-------------|------------|----------|----------|--------------|----------------|
| | 2400 MHz | 2440 MHz | 2500 MHz | | |
| 1 | 1.2 | 1.8 | 1.7 | PCB | ipex(MHF) |

* Detail antenna specification please refer to antenna datasheet and/or antenna measurement report.

2. The EUT incorporates a SISO function:

| 2.4 GHz Band | | |
|-----------------|-----------------------|-----|
| Modulation Mode | TX & RX Configuration | |
| 802.11b | 1TX | 1RX |
| 802.11g | 1TX | 1RX |
| 802.11n (HT20) | 1TX | 1RX |

3.3 Channel List

11 channels are provided for 802.11b, 802.11g, 802.11n (HT20):

| Channel | Frequency | Channel | Frequency |
|---------|-----------|---------|-----------|
| 1 | 2412 MHz | 7 | 2442 MHz |
| 2 | 2417 MHz | 8 | 2447 MHz |
| 3 | 2422 MHz | 9 | 2452 MHz |
| 4 | 2427 MHz | 10 | 2457 MHz |
| 5 | 2432 MHz | 11 | 2462 MHz |
| 6 | 2437 MHz | | |

3.4 Test Mode Applicability and Tested Channel Detail

| | |
|-------------|---|
| Pre-Scan: | 1. EUT can be used in the following ways: X-axis/ Y-axis/ Z-axis. Pre-scan these ways and find the worst case as a representative test condition. |
| Worst Case: | 1. X-axis/ Y-axis/ Z-axis Worst Condition: Z-axis |

Following channel(s) was (were) selected for the final test as listed below:

| Test Item | Mode | Signal Mode | Tested Channel | Modulation | Data Rate Parameter |
|--------------------------------|----------------|-------------|----------------|------------|---------------------|
| RF Output Power | 802.11b | CDD | 1, 6, 11 | DBPSK | 1Mb/s |
| | 802.11g | CDD | 1, 6, 11 | BPSK | 6Mb/s |
| | 802.11n (HT20) | CDD | 1, 6, 11 | BPSK | MCS0 |
| AC Power Conducted Emissions | 802.11n (HT20) | CDD | 11 | BPSK | MCS0 |
| Unwanted Emissions below 1 GHz | 802.11n (HT20) | CDD | 11 | BPSK | MCS0 |
| Unwanted Emissions above 1 GHz | 802.11n (HT20) | CDD | 1, 11 | BPSK | MCS0 |

3.5 Duty Cycle of Test Signal

802.11b: Duty cycle = 8.26 ms / 8.42 ms x 100% = 98.1%

802.11g: Duty cycle = 5.52 ms / 5.68 ms x 100% = 97.2%, duty factor = 10 * log (1/Duty cycle) = 0.12 dB

802.11n (HT20): Duty cycle = 0.985 ms / 1.175 ms x 100% = 83.8%, duty factor = 10 * log (1/Duty cycle) = 0.77 dB

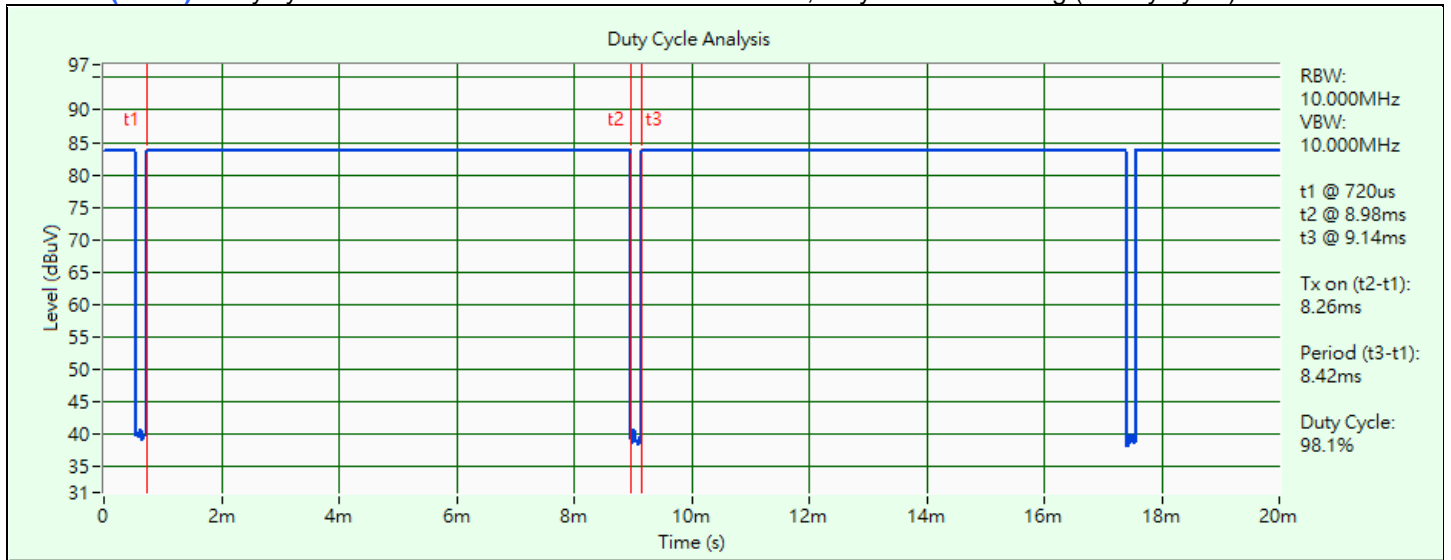

802.11b

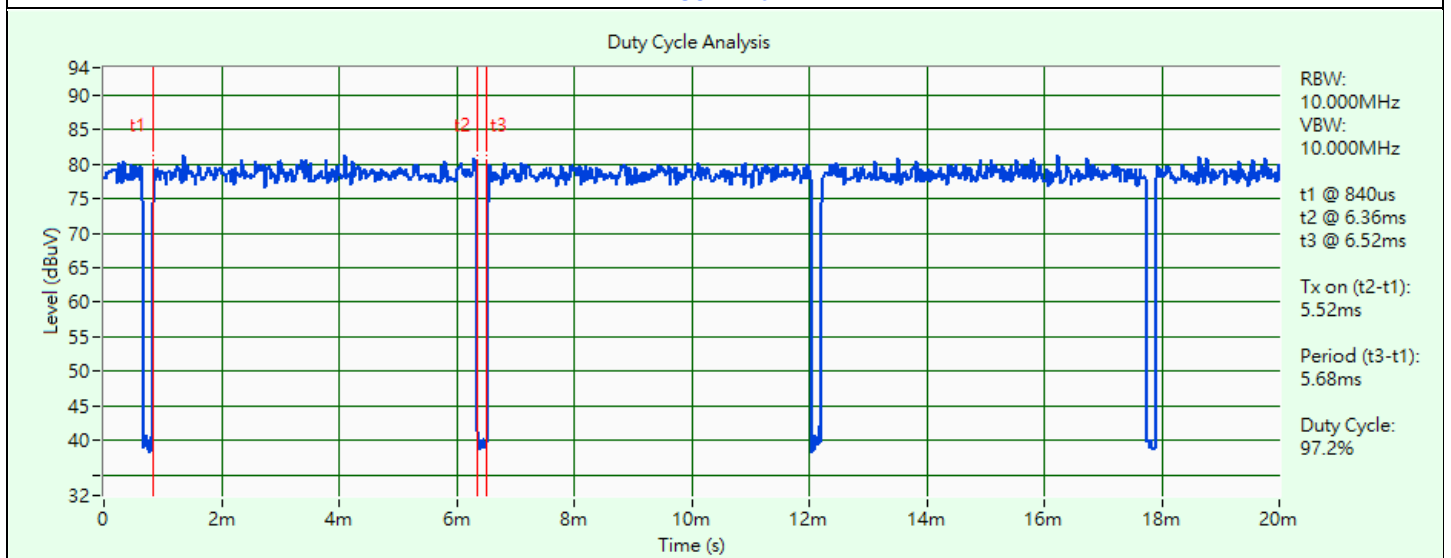

802.11g

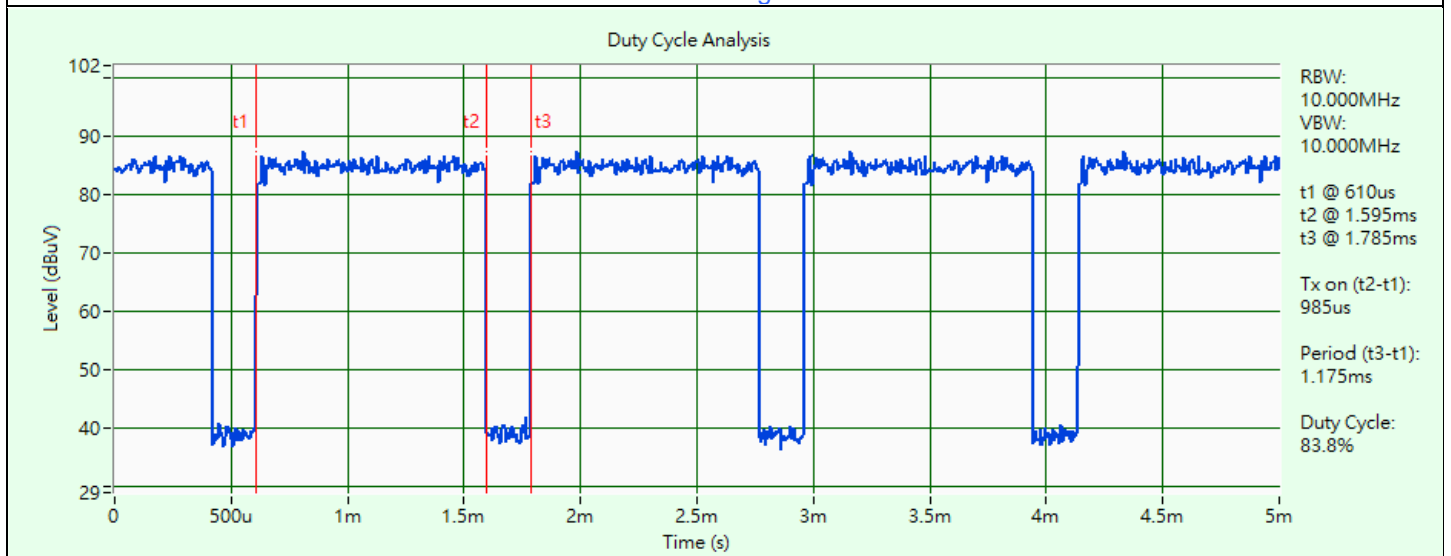

802.11n (HT20)

3.6 Test Program Used and Operation Descriptions

Controlling software QRCT3.0_00303 has been activated to set the EUT under transmission condition continuously at specific channel frequency.

3.7 Connection Diagram of EUT and Peripheral Devices

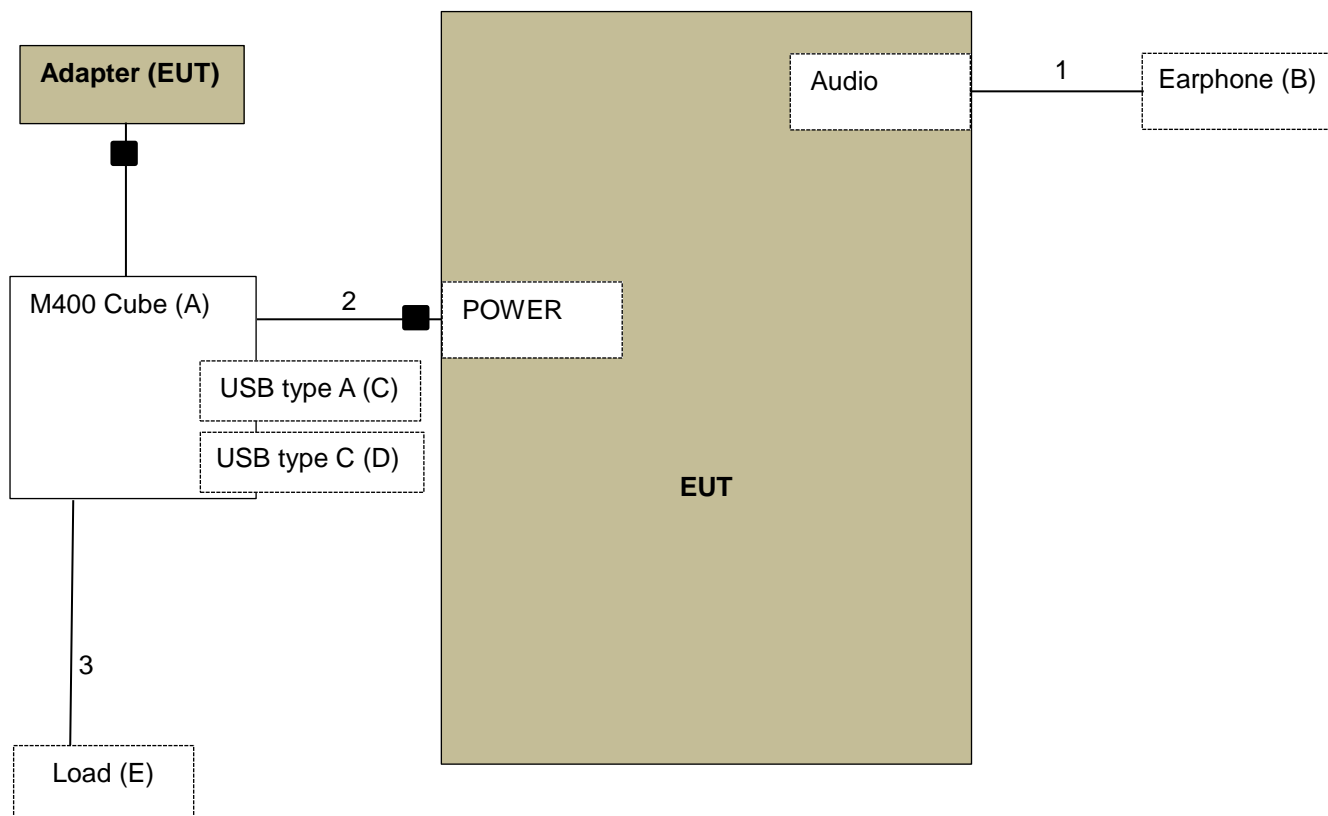

Under Table

3.8 Configuration of Peripheral Devices and Cable Connections

| ID | Product | Brand | Model No. | Serial No. | FCC ID | Remarks |
|----|------------|----------|-------------|------------|--------|-----------------------|
| A | M400 Cube | VeriFone | N/A | N/A | N/A | Supplied by applicant |
| B | Earphone | apple | MB77PFEB | N/A | N/A | Provided by Lab |
| C | USB Dongle | SanDisk | SDDDC3-032G | N/A | N/A | Provided by Lab |
| D | USB Dongle | SanDisk | SDDDC3-032G | N/A | N/A | Provided by Lab |
| E | Load | N/A | N/A | N/A | N/A | Provided by Lab |

| ID | Cable Descriptions | Qty. | Length (m) | Shielding (Yes/No) | Cores (Qty.) | Remarks |
|----|--------------------|------|------------|--------------------|--------------|-----------------------|
| 1 | Audio Cable | 1 | 1.0 | N | 0 | Provided by Lab |
| 2 | USB Cable | 1 | 1.3 | Y | 1 | Supplied by applicant |
| 3 | LAN Cable | 2 | 1.5 | N | 0 | Provided by Lab |

4 Test Instruments

The calibration interval of the all test instruments are 12 months and the calibrations are traceable to NML/ROC and NIST/USA.

4.1 RF Output Power

| Description Manufacturer | Model No. | Serial No. | Calibrated Date | Calibrated Until |
|--|-----------|---|--------------------|---------------------|
| USB Wideband Power Sensor KEYSIGHT | U2021XA | MY55050005/MY55190004/MY55190007/MY55210005 | 2022/7/13 | 2023/7/12 |

Notes:

1. The test was performed in Oven room.
2. Tested Date: 2023/4/25

4.2 AC Power Conducted Emissions

| Description Manufacturer | Model No. | Serial No. | Calibrated Date | Calibrated Until |
|---|-------------------------|----------------|--------------------|---------------------|
| DC-LISN SCHWARZBECK MESS- ELETRONIK | NNBM 8126G | 8126G-069 | 2022/11/9 | 2023/11/8 |
| LISN R&S | ESH2-Z5 | 100100 | 2023/3/7 | 2024/3/6 |
| | ESH3-Z5 | 100116 | 2023/2/15 | 2024/2/14 |
| LISN Schwarzbeck | NNLK 8121 | 8121-731 | 2022/5/26 | 2023/5/25 |
| RF Coaxial Cable WORKEN | 5D-FB | Cable-cond2-01 | 2022/9/3 | 2023/9/2 |
| Software BVADT | BVADT_Cond_ V7.3.7.4 | N/A | N/A | N/A |
| Test Receiver R&S | ESR3 | 102783 | 2022/12/21 | 2023/12/20 |
| V-LISN Schwarzbeck | NNBL 8226-2 | 8226-142 | 2022/8/31 | 2023/8/30 |

Notes:

1. The test was performed in HY - Conduction 2.
2. Tested Date: 2023/4/20

4.3 Unwanted Emissions below 1 GHz

| Description Manufacturer | Model No. | Serial No. | Calibrated Date | Calibrated Until |
|--------------------------------------|--------------------------|--|--------------------|---------------------|
| Antenna Tower Max-Full | UNAT_5+ | PAD-CH6-01 | N/A | N/A |
| Antenna Tower Controller Max-Full | MF-7802 | N/A | N/A | N/A |
| Bi_Log Antenna Schwarzbeck | VULB9168 | 9168-616 | 2022/10/26 | 2023/10/25 |
| Loop Antenna EMCI | EM-6879 | 269 | 2022/9/19 | 2023/9/18 |
| Loop Antenna TESEQ | HLA 6121 | 45745 | 2022/7/27 | 2023/7/26 |
| Pre-amplifier EMCI | EMC001340 | 980201 | 2022/9/23 | 2023/9/22 |
| Preamplifier Agilent | 310N | 187226 | 2022/6/14 | 2023/6/13 |
| RF Coaxial Cable EMCI | 5D-NM-BM | 140903+140902 | 2023/1/7 | 2024/1/6 |
| RF Coaxial Cable ETS-Lindgren | EMC104-SM-SM-10000 | Cable-CH1-01(RFC-SMS-100-SMS-120+RFC-SMS-100-SMS-4 | 2022/6/14 | 2023/6/13 |
| | RFC-SMS-100-SMS-24-IN | Cable-CH1-02(RFC-SMS-100-SMS-24) | 2022/6/14 | 2023/6/13 |
| Software BV ADT | ADT_Radiated_V7.6.15.9.5 | N/A | N/A | N/A |
| Test Receiver Agilent | N9038A | MY52260177 | 2022/9/19 | 2023/9/18 |
| Turn Table Max-Full | TT-1510 | N/A | N/A | N/A |
| Turn Table Controller Max-Full | MF-7802 | N/A | N/A | N/A |

Notes:

1. The test was performed in XD - 966 chamber 6.
2. Tested Date: 2023/4/11

4.4 Unwanted Emissions above 1 GHz

| Description Manufacturer | Model No. | Serial No. | Calibrated Date | Calibrated Until |
|---------------------------------------|-----------------------------------|--|--------------------|---------------------|
| Antenna Tower Max-Full | UNAT_5+ | PAD-CH6-01 | N/A | N/A |
| Antenna Tower Controller Max-Full | MF-7802 | N/A | N/A | N/A |
| Boresight antenna tower fixture BV | BAF-02 | 8 | N/A | N/A |
| Horn Antenna ETS-Lindgren | 3117 | 00143293 | 2022/11/13 | 2023/11/12 |
| Horn Antenna Schwarzbeck | BBHA 9170 | BBHA9170241 | 2022/10/20 | 2023/10/19 |
| Pre-Amplifier EMCI | EMC 184045 | 980116 | 2022/10/1 | 2023/9/30 |
| Preamplifier Agilent | 83017A | MY39501373 | 2022/6/14 | 2023/6/13 |
| RF Coaxial Cable ETS-Lindgren | EMC104-SM-SM-10000 | Cable-CH1-01(RFC-SMS-100-SMS-120+RFC-SMS-100-SMS-4 | 2022/6/14 | 2023/6/13 |
| | RFC-SMS-100-SMS-24-IN | Cable-CH1-02(RFC-SMS-100-SMS-24) | 2022/6/14 | 2023/6/13 |
| RF Coaxial Cable HUBER+SUHNER | SUCOFLEX 104 | CABLE-CH9-(250795/4) | 2023/1/7 | 2024/1/6 |
| RF Coaxial Cable HUBER+SUHNER&EMCI | SUCOFLEX 104& EMC104-SM-SM8000 | CABLE-CH9-02 (248780+171006) | 2023/1/7 | 2024/1/6 |
| Software BV ADT | ADT_Radiated_ V7.6.15.9.5 | N/A | N/A | N/A |
| Test Receiver Agilent | N9038A | MY52260177 | 2022/9/19 | 2023/9/18 |
| Turn Table Max-Full | TT-1510 | N/A | N/A | N/A |
| Turn Table Controller Max-Full | MF-7802 | N/A | N/A | N/A |

Notes:

1. The test was performed in XD - 966 chamber 6.
2. Tested Date: 2023/4/19

5 Limits of Test Items

5.1 RF Output Power

For systems using digital modulation in the 2400–2483.5 MHz bands: 1 Watt (30 dBm)

5.2 AC Power Conducted Emissions

| Frequency (MHz) | Conducted Limit (dBuV) | |
|-----------------|------------------------|---------|
| | Quasi-peak | Average |
| 0.15 - 0.5 | 66 - 56 | 56 - 46 |
| 0.50 - 5.0 | 56 | 46 |
| 5.0 - 30.0 | 60 | 50 |

Notes:

1. The lower limit shall apply at the transition frequencies.
2. The limit decreases in line with the logarithm of the frequency in the range of 0.15 to 0.50 MHz.

5.3 Unwanted Emissions below 1 GHz

Radiated emissions up to 1 GHz which fall in the restricted bands must comply with the radiated emission limits specified as below table. Other emissions shall be at least 20 dB below the highest level of the desired power:

| Frequencies (MHz) | Field Strength (microvolts/meter) | Measurement Distance (meters) |
|-------------------|-----------------------------------|-------------------------------|
| 0.009 ~ 0.490 | 2400/F(kHz) | 300 |
| 0.490 ~ 1.705 | 24000/F(kHz) | 30 |
| 1.705 ~ 30.0 | 30 | 30 |
| 30 ~ 88 | 100 | 3 |
| 88 ~ 216 | 150 | 3 |
| 216 ~ 960 | 200 | 3 |
| Above 960 | 500 | 3 |

Notes:

1. The lower limit shall apply at the transition frequencies.
2. Emission level (dBuV/m) = 20 log Emission level (uV/m).

5.4 Unwanted Emissions above 1 GHz

Radiated emissions above 1 GHz which fall in the restricted bands must comply with the radiated emission limits specified as below table. Other emissions shall be at least 20 dB below the highest level of the desired power:

| Frequencies (MHz) | Field Strength (microvolts/meter) | Measurement Distance (meters) |
|-------------------|-----------------------------------|-------------------------------|
| Above 960 | 500 | 3 |

Notes:

1. The lower limit shall apply at the transition frequencies.
2. Emission level (dBuV/m) = 20 log Emission level (uV/m).
3. For frequencies above 1000 MHz, the field strength limits are based on average detector, however, the peak field strength of any emission shall not exceed the maximum permitted average limits, specified above by more than 20 dB under any condition of modulation.

6 Test Arrangements

6.1 RF Output Power

6.1.1 Test Setup

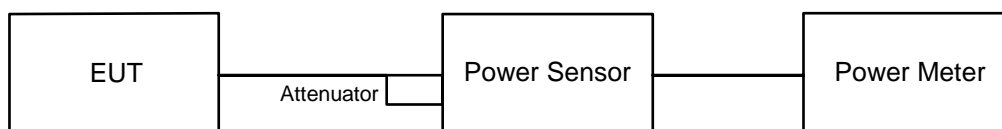

6.1.2 Test Procedure

Peak Power:

A peak power sensor was used on the output port of the EUT. A power meter was used to read the response of the peak power sensor. Record the power level.

Average Power:

Average power sensor was used to perform output power measurement, trigger and gating function of wide band power meter is enabled to measure max output power of TX on burst. Duty factor is not added to measured value.

6.2 AC Power Conducted Emissions

6.2.1 Test Setup

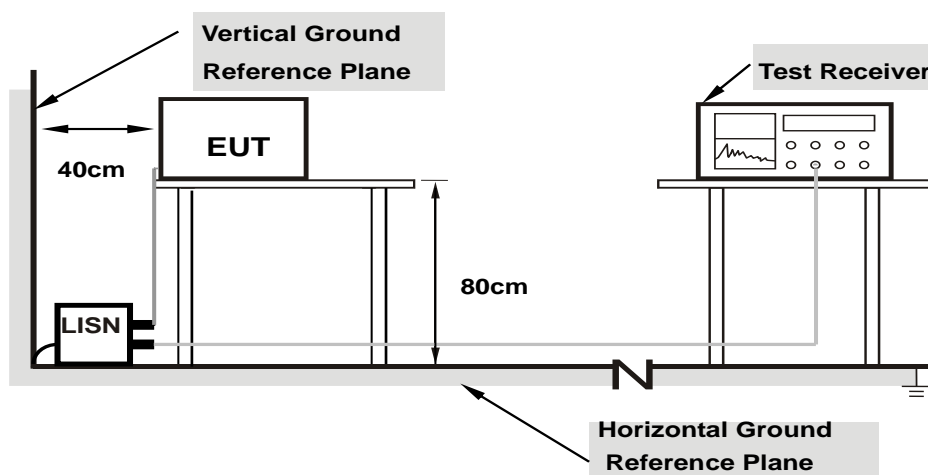

Note: 1.Support units were connected to second LISN.

For the actual test configuration, please refer to the attached file (Test Setup Photo).

6.2.2 Test Procedure

- The EUT was placed on a 0.8 meter to the top of table and placed 0.4 meters from the conducting wall of the shielded room with EUT being connected to the power mains through a line impedance stabilization network (LISN). Other support units were connected to the power mains through another LISN. The two LISNs provide 50 ohm/ 50 uH of coupling impedance for the measuring instrument.
- Both lines of the power mains connected to the EUT were checked for maximum conducted interference.
- The frequency range from 150 kHz to 30 MHz was searched. Emission levels under (Limit – 20 dB) was not recorded.

Note: The resolution bandwidth and video bandwidth of test receiver is 9 kHz for quasi-peak detection (QP) and average detection (AV) at frequency 0.15 MHz-30 MHz.

6.3 Unwanted Emissions below 1 GHz

6.3.1 Test Setup

For Radiated emission below 30 MHz

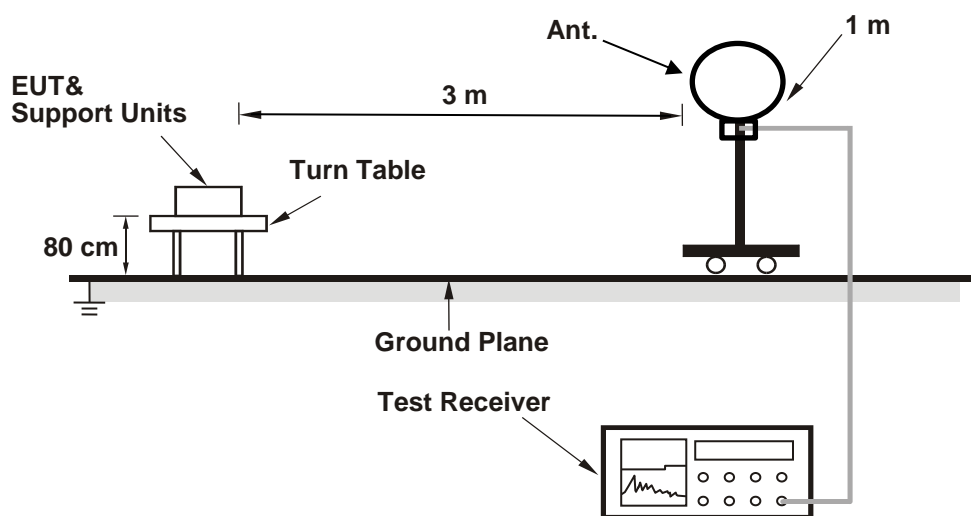

For Radiated emission above 30 MHz

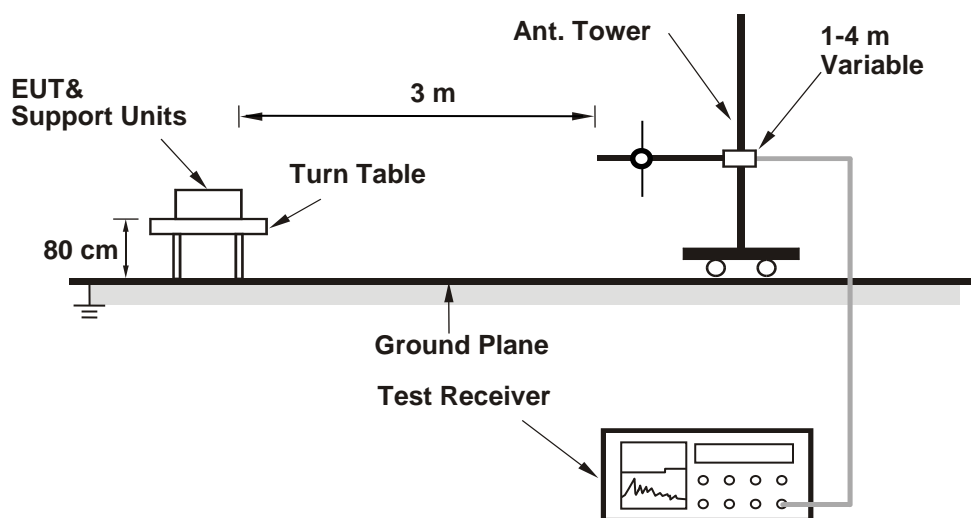

For the actual test configuration, please refer to the attached file (Test Setup Photo).

6.3.2 Test Procedure

For Radiated emission below 30 MHz

- a. The EUT was placed on the top of a rotating table 0.8 meters above the ground at 3 meter chamber room for test. The table was rotated 360 degrees to determine the position of the highest radiation.
- b. The EUT was set 3 meters away from the interference-receiving antenna, which was mounted on the top of a variable-height antenna tower.
- c. Parallel, perpendicular, and ground-parallel orientations of the antenna are set to make the measurement.
- d. For each suspected emission, the EUT was arranged to its worst case and the rotatable table was turned from 0 degrees to 360 degrees to find the maximum reading.
- e. The test-receiver system was set to Quasi-Peak Detect Function and Specified Bandwidth with Maximum Hold Mode, except for the frequency band (9 kHz to 90 kHz and 110 kHz to 490 kHz) set to average detect function and peak detect function.

Notes:

1. The resolution bandwidth and video bandwidth of test receiver/spectrum analyzer is 200 Hz at frequency below 150 kHz.
2. The resolution bandwidth and video bandwidth of test receiver/spectrum analyzer is 9 kHz or 10 kHz at frequency (150 kHz to 30 MHz).
3. All modes of operation were investigated and the worst-case emissions are reported.

For Radiated emission above 30 MHz

- a. The EUT was placed on the top of a rotating table 0.8 meters above the ground at 3 meter chamber room for test. The table was rotated 360 degrees to determine the position of the highest radiation.
- b. The EUT was set 3 meters away from the interference-receiving antenna, which was mounted on the top of a variable-height antenna tower.
- c. The height of antenna is varied from one meter to four meters above the ground to determine the maximum value of the field strength. Both horizontal and vertical polarizations of the antenna are set to make the measurement.
- d. For each suspected emission, the EUT was arranged to its worst case and then the antenna was tuned to heights from 1 meter to 4 meters and the rotatable table was turned from 0 degrees to 360 degrees to find the maximum reading.
- e. The test-receiver system was set to quasi-peak detect function and specified bandwidth with maximum hold mode when the test frequency is below 1 GHz.

Notes:

1. The resolution bandwidth and video bandwidth of test receiver/spectrum analyzer is 120 kHz for Quasi-peak detection (QP) at frequency below 1 GHz.
2. All modes of operation were investigated and the worst-case emissions are reported.

6.4 Unwanted Emissions above 1 GHz

6.4.1 Test Setup

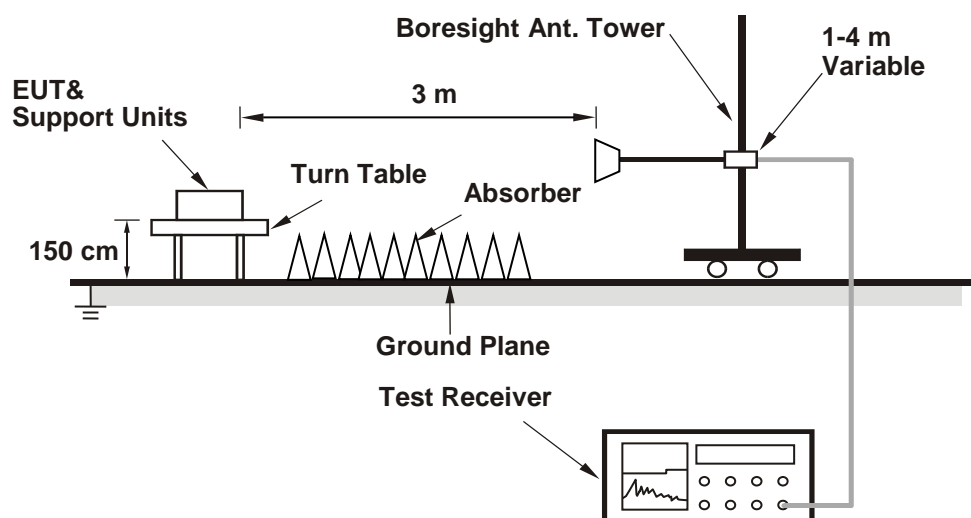

For the actual test configuration, please refer to the attached file (Test Setup Photo).

6.4.2 Test Procedure

- The EUT was placed on the top of a rotating table 1.5 meters above the ground at 3 meter chamber room for test. The table was rotated 360 degrees to determine the position of the highest radiation.
- The EUT was set 3 meters away from the interference-receiving antenna, which was mounted on the top of a variable-height antenna tower.
- The height of antenna is varied from one meter to four meters above the ground to determine the maximum value of the field strength. Both horizontal and vertical polarizations of the antenna are set to make the measurement.
- For each suspected emission, the EUT was arranged to its worst case and then the antenna was tuned to heights from 1 meter to 4 meters and the rotatable table was turned from 0 degrees to 360 degrees to find the maximum reading.
- The test-receiver system was set to peak and average detects function and specified bandwidth with maximum hold mode when the test frequency is above 1 GHz. If the peak reading value also meets average limit, measurement with the average detector is unnecessary.

Notes:

- The resolution bandwidth of test receiver/spectrum analyzer is 1 MHz and the video bandwidth is 3 MHz for Peak detection (PK) and Average detection (AV) at frequency above 1 GHz.
- For fundamental and harmonic signal measurement, the resolution bandwidth of test receiver/spectrum analyzer is 1 MHz and the video bandwidth is $\geq 1/T$ (Duty cycle $< 98\%$) or 10 Hz (Duty cycle $\geq 98\%$) for Average detection (AV) at frequency above 1 GHz.
- All modes of operation were investigated and the worst-case emissions are reported.

7 Test Results of Test Item

7.1 RF Output Power

| | | | | | |
|--------------|----------------|---------------------------|--------------|------------|---------------------|
| Input Power: | 120 Vac, 60 Hz | Environmental Conditions: | 25°C, 60% RH | Tested By: | Alan Wu, Edison Lee |
|--------------|----------------|---------------------------|--------------|------------|---------------------|

For Peak Power

802.11b

| Chan. | Chan. Freq. (MHz) | Peak Power (mW) | Peak Power (dBm) | Power Limit (dBm) | Test Result |
|-------|-------------------|-----------------|------------------|-------------------|-------------|
| 1 | 2412 | 52.119 | 17.17 | 30 | Pass |
| 6 | 2437 | 57.412 | 17.59 | 30 | Pass |
| 11 | 2462 | 55.847 | 17.47 | 30 | Pass |

Note: The antenna gain is 1.8 dBi < 6 dBi, so the output power limit shall not be reduced.

802.11g

| Chan. | Chan. Freq. (MHz) | Peak Power (mW) | Peak Power (dBm) | Power Limit (dBm) | Test Result |
|-------|-------------------|-----------------|------------------|-------------------|-------------|
| 1 | 2412 | 110.662 | 20.44 | 30 | Pass |
| 6 | 2437 | 137.721 | 21.39 | 30 | Pass |
| 11 | 2462 | 72.611 | 18.61 | 30 | Pass |

Note: The antenna gain is 1.8 dBi < 6 dBi, so the output power limit shall not be reduced.

802.11n (HT20)

| Chan. | Chan. Freq. (MHz) | Peak Power (mW) | Peak Power (dBm) | Power Limit (dBm) | Test Result |
|-------|-------------------|-----------------|------------------|-------------------|-------------|
| 1 | 2412 | 100 | 20.00 | 30 | Pass |
| 6 | 2437 | 126.183 | 21.01 | 30 | Pass |
| 11 | 2462 | 67.143 | 18.27 | 30 | Pass |

Note: The antenna gain is 1.8 dBi < 6 dBi, so the output power limit shall not be reduced.

For Average Power

802.11b

| Chan. | Chan. Freq. (MHz) | Average Power (mW) | Average Power (dBm) |
|-------|-------------------|--------------------|---------------------|
| 1 | 2412 | 27.353 | 14.37 |
| 6 | 2437 | 28.973 | 14.62 |
| 11 | 2462 | 28.576 | 14.56 |

802.11g

| Chan. | Chan. Freq. (MHz) | Average Power (mW) | Average Power (dBm) |
|-------|-------------------|--------------------|---------------------|
| 1 | 2412 | 23.878 | 13.78 |
| 6 | 2437 | 28.973 | 14.62 |
| 11 | 2462 | 15.346 | 11.86 |

802.11n (HT20)

| Chan. | Chan. Freq. (MHz) | Average Power (mW) | Average Power (dBm) |
|-------|-------------------|--------------------|---------------------|
| 1 | 2412 | 19.999 | 13.01 |
| 6 | 2437 | 22.387 | 13.50 |
| 11 | 2462 | 12.942 | 11.12 |

7.2 AC Power Conducted Emissions

| | | | |
|-----------------|----------------|--|---------------------------------------|
| RF Mode | 802.11n (HT20) | Channel | CH 11 : 2462 MHz |
| Frequency Range | 150kHz ~ 30MHz | Detector Function & Resolution Bandwidth | Quasi-Peak (QP) / Average (AV), 9 kHz |
| Input Power | 120 Vac, 60 Hz | Environmental Conditions | 23.5°C, 72.3% RH |
| Tested By | Thomas Cheng | | |

| Phase Of Power : Line (L) | | | | | | | | | | |
|---------------------------|-----------------|------------------------|----------------------|--------------|-----------------------|--------------|--------------|--------------|---------------|---------------|
| No | Frequency (MHz) | Correction Factor (dB) | Reading Value (dBuV) | | Emission Level (dBuV) | | Limit (dBuV) | | Margin (dB) | |
| | | | Q.P. | AV. | Q.P. | AV. | Q.P. | AV. | Q.P. | AV. |
| 1 | 0.16200 | 10.11 | 30.18 | 15.28 | 40.29 | 25.39 | 65.36 | 55.36 | -25.07 | -29.97 |
| 2 | 0.22200 | 10.13 | 26.75 | 10.06 | 36.88 | 20.19 | 62.74 | 52.74 | -25.86 | -32.55 |
| 3 | 0.39000 | 10.14 | 21.18 | 19.61 | 31.32 | 29.75 | 58.06 | 48.06 | -26.74 | -18.31 |
| 4 | 0.66600 | 10.15 | 11.90 | 6.08 | 22.05 | 16.23 | 56.00 | 46.00 | -33.95 | -29.77 |
| 5 | 8.39800 | 10.26 | 11.85 | 5.62 | 22.11 | 15.88 | 60.00 | 50.00 | -37.89 | -34.12 |
| 6 | 15.90200 | 10.37 | 10.30 | 4.35 | 20.67 | 14.72 | 60.00 | 50.00 | -39.33 | -35.28 |

Remarks:

1. Q.P. and AV. are abbreviations of quasi-peak and average individually.
2. The emission levels of other frequencies were very low against the limit.
3. Margin value = Emission level – Limit value
4. Correction factor = Insertion loss + Cable loss
5. Emission Level = Correction Factor + Reading Value

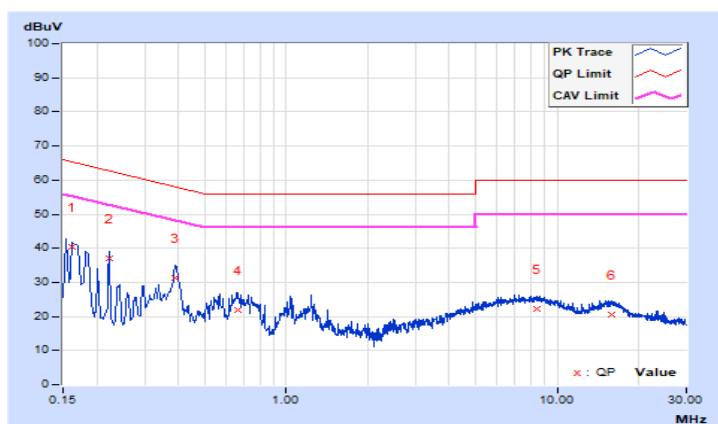

| | | | |
|------------------------|----------------|---|---------------------------------------|
| RF Mode | 802.11n (HT20) | Channel | CH 11 : 2462 MHz |
| Frequency Range | 150kHz ~ 30MHz | Detector Function & Resolution Bandwidth | Quasi-Peak (QP) / Average (AV), 9 kHz |
| Input Power | 120 Vac, 60 Hz | Environmental Conditions | 23.5°C, 72.3% RH |
| Tested By | Thomas Cheng | | |

| Phase Of Power : Neutral (N) | | | | | | | | | | |
|------------------------------|-----------------|------------------------|----------------------|-------|-----------------------|-------|--------------|-------|-------------|--------|
| No | Frequency (MHz) | Correction Factor (dB) | Reading Value (dBuV) | | Emission Level (dBuV) | | Limit (dBuV) | | Margin (dB) | |
| | | | Q.P. | AV. | Q.P. | AV. | Q.P. | AV. | Q.P. | AV. |
| 1 | 0.15800 | 10.12 | 32.65 | 17.24 | 42.77 | 27.36 | 65.57 | 55.57 | -22.80 | -28.21 |
| 2 | 0.18133 | 10.14 | 28.46 | 12.51 | 38.60 | 22.65 | 64.42 | 54.42 | -25.82 | -31.77 |
| 3 | 0.39400 | 10.16 | 19.20 | 16.51 | 29.36 | 26.67 | 57.98 | 47.98 | -28.62 | -21.31 |
| 4 | 0.65763 | 10.17 | 12.69 | 6.55 | 22.86 | 16.72 | 56.00 | 46.00 | -33.14 | -29.28 |
| 5 | 11.95000 | 10.41 | 12.05 | 4.16 | 22.46 | 14.57 | 60.00 | 50.00 | -37.54 | -35.43 |
| 6 | 21.52600 | 10.56 | 8.62 | 1.87 | 19.18 | 12.43 | 60.00 | 50.00 | -40.82 | -37.57 |

Remarks:

1. Q.P. and AV. are abbreviations of quasi-peak and average individually.
2. The emission levels of other frequencies were very low against the limit.
3. Margin value = Emission level – Limit value
4. Correction factor = Insertion loss + Cable loss
5. Emission Level = Correction Factor + Reading Value

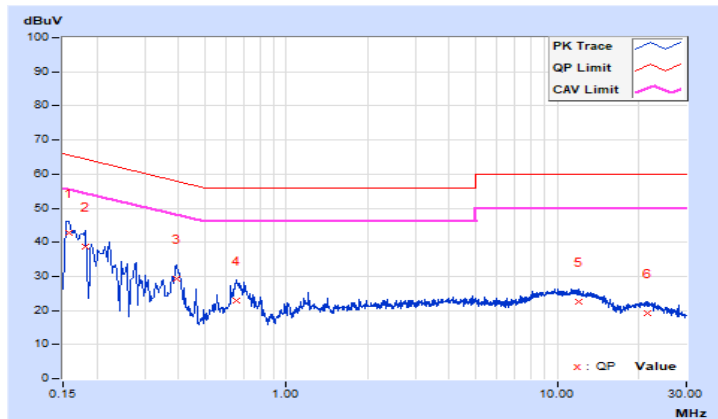

7.3 Unwanted Emissions below 1 GHz

| | | | |
|------------------------|----------------|--|------------------|
| RF Mode | 802.11n (HT20) | Channel | CH 11 : 2462 MHz |
| Frequency Range | 30 MHz ~ 1 GHz | Detector Function & Bandwidth | (QP) RB = 120kHz |
| Input Power | 120 Vac, 60 Hz | Environmental Conditions | 25°C, 60% RH |
| Tested By | Karl Lee | | |

| Antenna Polarity & Test Distance : Horizontal at 3 m | | | | | | | | |
|--|-----------------|-------------------------|----------------|-------------|--------------------|----------------------|------------------|--------------------------|
| No | Frequency (MHz) | Emission Level (dBuV/m) | Limit (dBuV/m) | Margin (dB) | Antenna Height (m) | Table Angle (Degree) | Raw Value (dBuV) | Correction Factor (dB/m) |
| 1 | 94.55 | 35.8 QP | 43.5 | -7.7 | 1.35 H | 22 | 53.9 | -18.1 |
| 2 | 176.63 | 27.6 QP | 43.5 | -15.9 | 1.92 H | 206 | 41.3 | -13.7 |
| 3 | 284.04 | 34.9 QP | 46.0 | -11.1 | 1.27 H | 62 | 47.4 | -12.5 |
| 4 | 357.65 | 31.8 QP | 46.0 | -14.2 | 1.77 H | 119 | 42.6 | -10.8 |
| 5 | 456.21 | 28.3 QP | 46.0 | -17.7 | 1.39 H | 267 | 36.5 | -8.2 |
| 6 | 495.27 | 25.7 QP | 46.0 | -20.3 | 1.63 H | 174 | 33.4 | -7.7 |

Remarks:

1. Emission Level(dBuV/m) = Raw Value(dBuV) + Correction Factor(dB/m)
2. Correction Factor(dB/m) = Antenna Factor(dB/m) + Cable Factor(dB) – Pre-Amplifier Factor(dB)
3. Margin value = Emission Level – Limit value
4. The other emission levels were very low against the limit of frequency range 30 MHz ~ 1 GHz.
5. The emission levels were very low against the limit of frequency range 9 kHz ~ 30 MHz: the amplitude of spurious emissions attenuated more than 20 dB below the permissible value to be report.

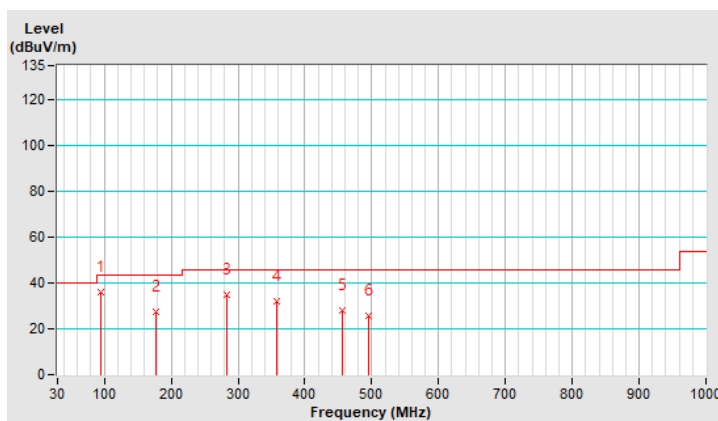

| | | | |
|------------------------|----------------|--|------------------|
| RF Mode | 802.11n (HT20) | Channel | CH 11 : 2462 MHz |
| Frequency Range | 30 MHz ~ 1 GHz | Detector Function & Bandwidth | (QP) RB = 120kHz |
| Input Power | 120 Vac, 60 Hz | Environmental Conditions | 25°C, 60% RH |
| Tested By | Karl Lee | | |

| Antenna Polarity & Test Distance : Vertical at 3 m | | | | | | | | |
|--|-----------------|-------------------------|----------------|-------------|--------------------|----------------------|------------------|--------------------------|
| No | Frequency (MHz) | Emission Level (dBuV/m) | Limit (dBuV/m) | Margin (dB) | Antenna Height (m) | Table Angle (Degree) | Raw Value (dBuV) | Correction Factor (dB/m) |
| 1 | 34.15 | 35.6 QP | 40.0 | -4.4 | 1.25 V | 317 | 49.7 | -14.1 |
| 2 | 54.01 | 33.8 QP | 40.0 | -6.2 | 1.29 V | 341 | 46.8 | -13.0 |
| 3 | 274.68 | 32.5 QP | 46.0 | -13.5 | 1.04 V | 116 | 45.5 | -13.0 |
| 4 | 437.59 | 31.4 QP | 46.0 | -14.6 | 1.74 V | 305 | 40.0 | -8.6 |
| 5 | 517.61 | 29.7 QP | 46.0 | -16.3 | 1.51 V | 149 | 37.0 | -7.3 |
| 6 | 574.63 | 28.7 QP | 46.0 | -17.3 | 1.08 V | 24 | 34.8 | -6.1 |

Remarks:

1. Emission Level(dBuV/m) = Raw Value(dBuV) + Correction Factor(dB/m)
2. Correction Factor(dB/m) = Antenna Factor(dB/m) + Cable Factor(dB) – Pre-Amplifier Factor(dB)
3. Margin value = Emission Level – Limit value
4. The other emission levels were very low against the limit of frequency range 30 MHz ~ 1 GHz.
5. The emission levels were very low against the limit of frequency range 9 kHz ~ 30 MHz: the amplitude of spurious emissions attenuated more than 20 dB below the permissible value to be report.

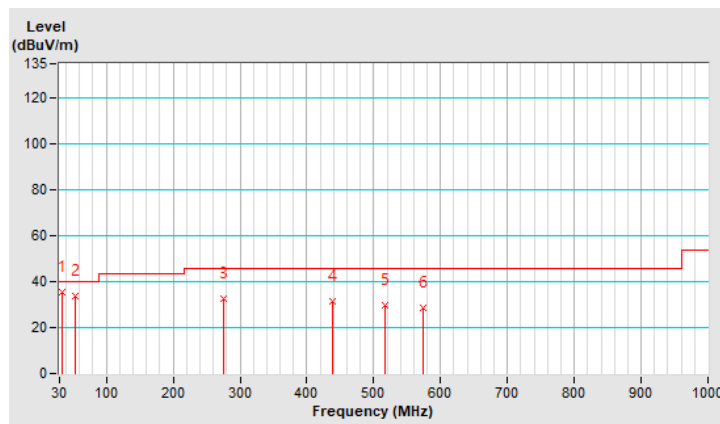

7.4 Unwanted Emissions above 1 GHz

| | | | |
|------------------------|----------------|--|--|
| RF Mode | 802.11n (HT20) | Channel | CH 1 : 2412 MHz |
| Frequency Range | 1 GHz ~ 25 GHz | Detector Function & Bandwidth | (PK) RB = 1 MHz, VB = 3 MHz (AV) RB = 1 MHz, VB = 3 kHz |
| Input Power | 120 Vac, 60 Hz | Environmental Conditions | 25°C, 60% RH |
| Tested By | Karl Lee | | |

| Antenna Polarity & Test Distance : Horizontal at 3 m | | | | | | | | |
|--|-----------------|-------------------------|----------------|-------------|--------------------|----------------------|------------------|--------------------------|
| No | Frequency (MHz) | Emission Level (dBuV/m) | Limit (dBuV/m) | Margin (dB) | Antenna Height (m) | Table Angle (Degree) | Raw Value (dBuV) | Correction Factor (dB/m) |
| 1 | 2390.00 | 60.8 PK | 74.0 | -13.2 | 1.42 H | 121 | 54.2 | 6.6 |
| 2 | 2390.00 | 50.2 AV | 54.0 | -3.8 | 1.42 H | 121 | 43.6 | 6.6 |
| 3 | *2412.00 | 104.7 PK | | | 1.42 H | 121 | 66.6 | 38.1 |
| 4 | *2412.00 | 96.3 AV | | | 1.42 H | 121 | 58.2 | 38.1 |
| 5 | 4824.00 | 48.8 PK | 74.0 | -25.2 | 1.92 H | 61 | 37.2 | 11.6 |
| 6 | 4824.00 | 41.6 AV | 54.0 | -12.4 | 1.92 H | 61 | 30.0 | 11.6 |
| Antenna Polarity & Test Distance : Vertical at 3 m | | | | | | | | |
| No | Frequency (MHz) | Emission Level (dBuV/m) | Limit (dBuV/m) | Margin (dB) | Antenna Height (m) | Table Angle (Degree) | Raw Value (dBuV) | Correction Factor (dB/m) |
| 1 | 2390.00 | 67.8 PK | 74.0 | -6.2 | 1.28 V | 209 | 61.2 | 6.6 |
| 2 | 2390.00 | 52.0 AV | 54.0 | -2.0 | 1.28 V | 209 | 45.4 | 6.6 |
| 3 | *2412.00 | 106.0 PK | | | 1.28 V | 209 | 67.9 | 38.1 |
| 4 | *2412.00 | 98.6 AV | | | 1.28 V | 209 | 60.5 | 38.1 |
| 5 | 4824.00 | 49.1 PK | 74.0 | -24.9 | 2.16 V | 185 | 37.5 | 11.6 |
| 6 | 4824.00 | 41.8 AV | 54.0 | -12.2 | 2.16 V | 185 | 30.2 | 11.6 |

Remarks:

1. Emission Level(dBuV/m) = Raw Value(dBuV) + Correction Factor(dB/m)
2. Correction Factor(dB/m) = Antenna Factor(dB/m) + Cable Factor(dB) – Pre-Amplifier Factor(dB)
3. Margin value = Emission Level – Limit value
4. The other emission levels were very low against the limit.
5. " * " : Fundamental frequency, the limit was restricted at the RF Output Power.



| | | | |
|-----------------|----------------|-------------------------------|--|
| RF Mode | 802.11n (HT20) | Channel | CH 11 : 2462 MHz |
| Frequency Range | 1 GHz ~ 25 GHz | Detector Function & Bandwidth | (PK) RB = 1 MHz, VB = 3 MHz (AV) RB = 1 MHz, VB = 3 kHz |
| Input Power | 120 Vac, 60 Hz | Environmental Conditions | 25°C, 60% RH |
| Tested By | Karl Lee | | |

Antenna Polarity & Test Distance : Horizontal at 3 m

| No | Frequency (MHz) | Emission Level (dBuV/m) | Limit (dBuV/m) | Margin (dB) | Antenna Height (m) | Table Angle (Degree) | Raw Value (dBuV) | Correction Factor (dB/m) |
|----|-----------------|-------------------------|----------------|-------------|--------------------|----------------------|------------------|--------------------------|
| 1 | *2462.00 | 101.6 PK | | | 1.41 H | 136 | 63.7 | 37.9 |
| 2 | *2462.00 | 93.2 AV | | | 1.41 H | 136 | 55.3 | 37.9 |
| 3 | 2483.50 | 64.7 PK | 74.0 | -9.3 | 1.41 H | 136 | 58.1 | 6.6 |
| 4 | 2483.50 | 50.8 AV | 54.0 | -3.2 | 1.41 H | 136 | 44.2 | 6.6 |
| 5 | 4924.00 | 49.3 PK | 74.0 | -24.7 | 1.55 H | 84 | 37.6 | 11.7 |
| 6 | 4924.00 | 42.0 AV | 54.0 | -12.0 | 1.55 H | 84 | 30.3 | 11.7 |

Antenna Polarity & Test Distance : Vertical at 3 m

| No | Frequency (MHz) | Emission Level (dBuV/m) | Limit (dBuV/m) | Margin (dB) | Antenna Height (m) | Table Angle (Degree) | Raw Value (dBuV) | Correction Factor (dB/m) |
|----|-----------------|-------------------------|----------------|-------------|--------------------|----------------------|------------------|--------------------------|
| 1 | *2462.00 | 103.6 PK | | | 1.28 V | 212 | 65.7 | 37.9 |
| 2 | *2462.00 | 95.3 AV | | | 1.28 V | 212 | 57.4 | 37.9 |
| 3 | 2483.50 | 66.6 PK | 74.0 | -7.4 | 1.28 V | 212 | 60.0 | 6.6 |
| 4 | 2483.50 | 52.0 AV | 54.0 | -2.0 | 1.28 V | 212 | 45.4 | 6.6 |
| 5 | 4924.00 | 49.2 PK | 74.0 | -24.8 | 1.29 V | 260 | 37.5 | 11.7 |
| 6 | 4924.00 | 41.8 AV | 54.0 | -12.2 | 1.29 V | 260 | 30.1 | 11.7 |

Remarks:

1. Emission Level(dBuV/m) = Raw Value(dBuV) + Correction Factor(dB/m)
2. Correction Factor(dB/m) = Antenna Factor(dB/m) + Cable Factor(dB) – Pre-Amplifier Factor(dB)
3. Margin value = Emission Level – Limit value
4. The other emission levels were very low against the limit.
5. " * ": Fundamental frequency, the limit was restricted at the RF Output Power.



Plot of Band Edge

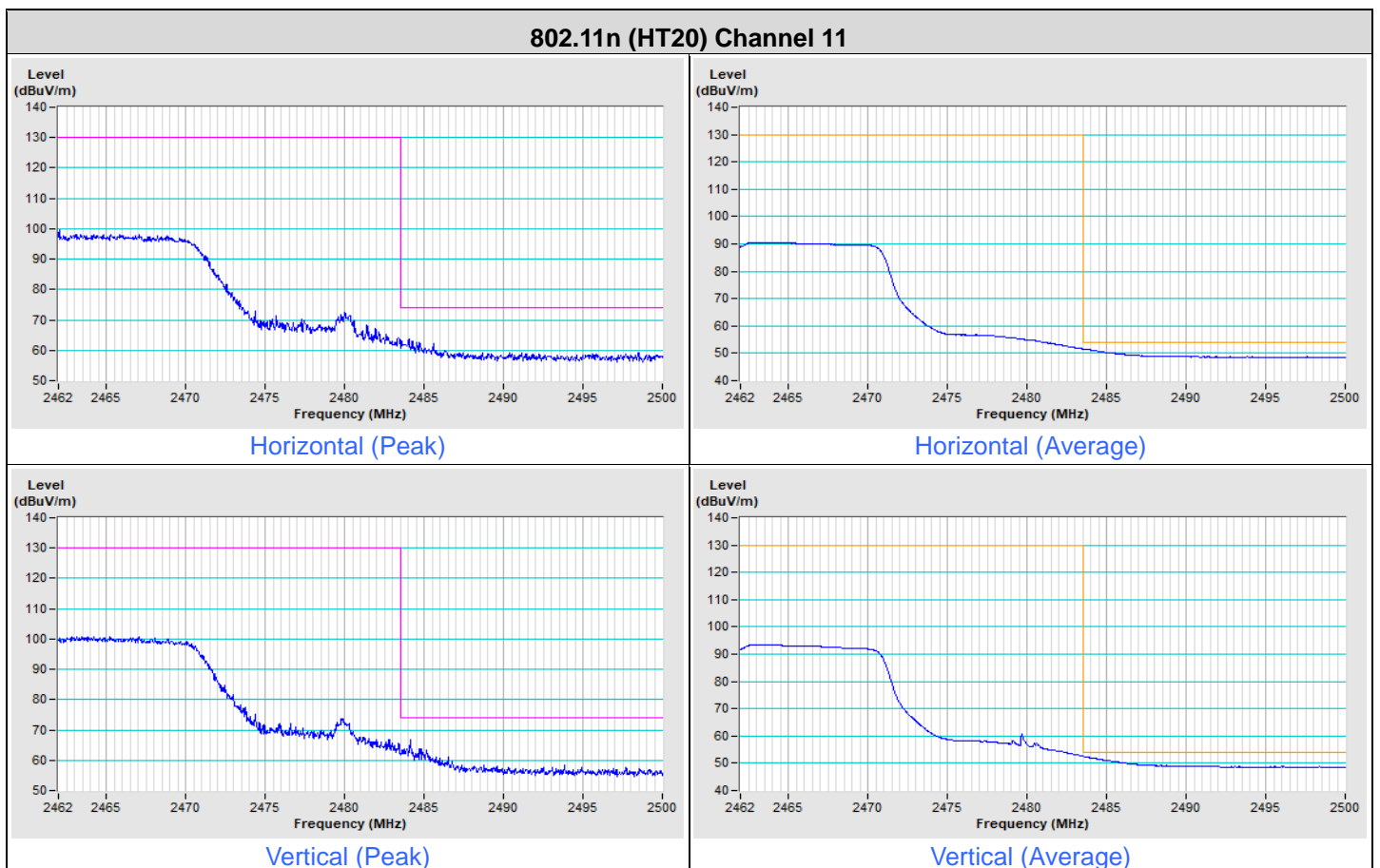
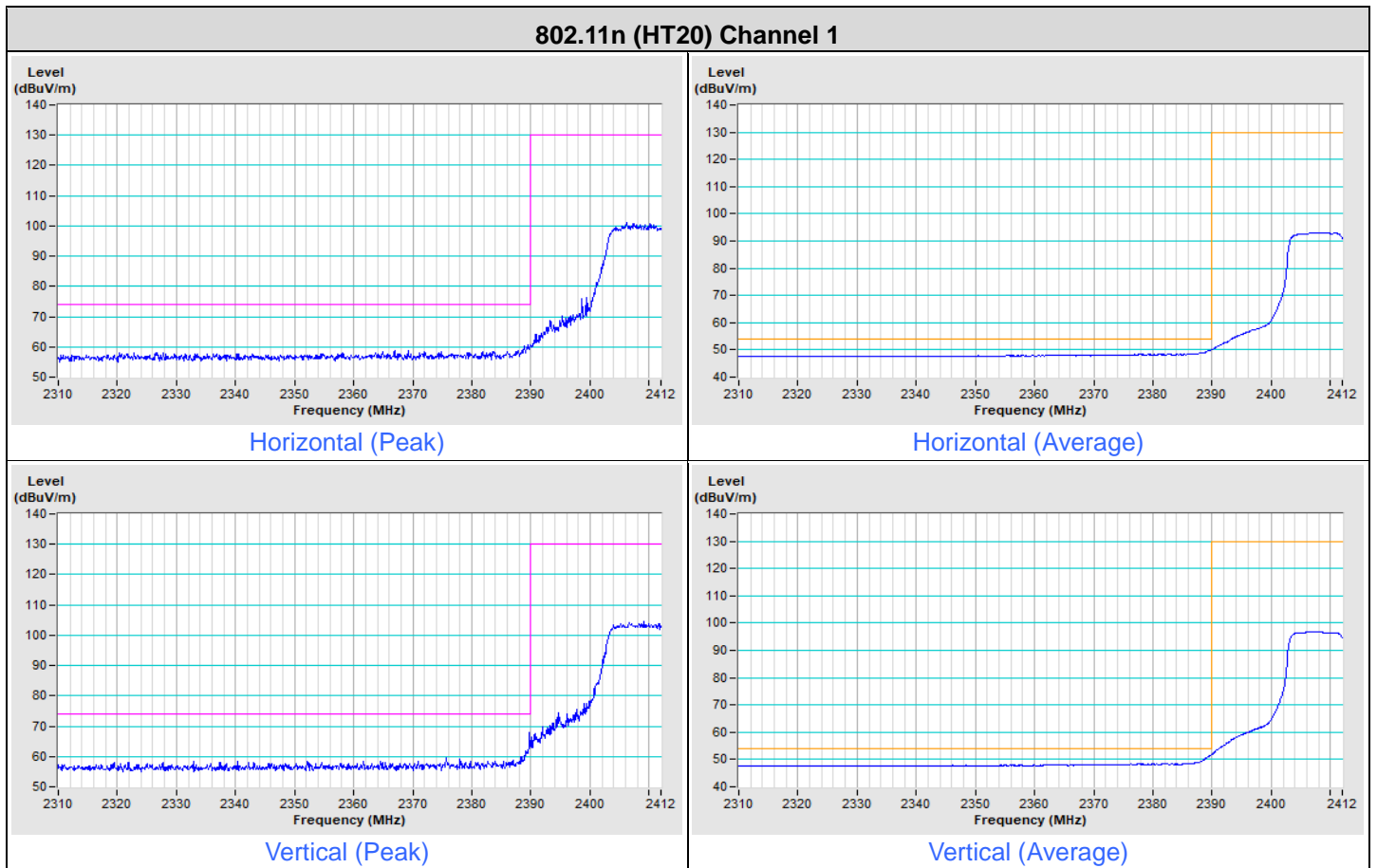

8 Pictures of Test Arrangements

Please refer to the attached file (Test Setup Photo)

9 Information of the Testing Laboratories

We, Bureau Veritas Consumer Products Services (H.K.) Ltd., Taoyuan Branch, were founded in 1988 to provide our best service in EMC, Radio, Telecom and Safety consultation. Our laboratories are FCC recognized accredited test firms and accredited according to ISO/IEC 17025.

If you have any comments, please feel free to contact us at the following:

Lin Kou EMC/RF Lab

Tel: 886-2-26052180

Fax: 886-2-26051924

Hsin Chu EMC/RF/Telecom Lab

Tel: 886-3-6668565

Fax: 886-3-6668323

Hwa Ya EMC/RF/Safety Lab

Tel: 886-3-3183232

Fax: 886-3-3270892

Email: service.adt@bureauveritas.com

Web Site: <http://ee.bureauveritas.com.tw>

The address and road map of all our labs can be found in our web site also.

--- END ---