

FCC Test Report

for

Contactless Card Reader

Trade Name : VeriFone
Model Number : Mx8SERIES CR3
P/N : P090-XXX-XX-R
FCC ID : B32-MX8SERIESCR3
Report Number : RF-V040-0912-014
Date of Receipt : Jan. 7, 2010
Date of Report : Feb. 3, 2010

Prepared for

VeriFone Inc.

1400 West Stanford Ranch Road Suite 200 Rocklin, CA 95765 USA.

Prepared by



Central Research Technology Co.

EMC Test Laboratory

No.11, Lane41, Fushuen St., Jungshan Chiu, Taipei, Taiwan, 104, R.O.C.



NVLAP LAB CODE 200575-0

This report shall not be reproduced, except in full, without the written approval of Central Research Technology Co.. It may be duplicated completely in its entirety for legal use with the permission of the applicant. It should not be used to claim product endorsement by NVLAP, NIST or any U.S. government agency. The test result in the report applies only to the sample tested.

Certification

Equipment under Test : Contactless Card Reader
Model No. : Mx8SERIES CR3
P/N : P090-XXX-XX-R
FCC ID : B32-MX8SERIESCR3
Manufacturer : Sanmina-SCI Systems (Kunshan) Co.,Ltd.
WONG'S ELECTRONICS CO., LTD
Applicant : VeriFone Inc.
Address : 1400 West Stanford Ranch Road Suite 200 Rocklin, CA
95765 USA
Date of Testing : Jan. 11, 2010 ~ Jan. 18, 2010
Applicable Standards : 47 CFR part 15, Subpart C
Deviation : N/A
Condition of Test Sample : Enigneering Sample



We, **Central Research Technology Co.**, hereby certify that one sample of the designated product was tested in our facility during the period mentioned above. The test records, data evaluation and Equipment Under Test (EUT) configurations shown in the present report are true and accurate representation of the measurements of the sample's RF characteristics under the conditions herein specified.

The test results show that the EUT as described in the present report is in compliance with the requirements set forth in the standards mentioned above and apply to the tested sample identified in the present report only. The test report shall not be reproduced, except in its entirety, without the written approval of Central Research Technology Co.

PREPARED BY : Cathy Chen , DATE : Feb. 3, 2010
(Cathy Chen/ Technical Manager)
APPROVED BY : J. Y. Shih , DATE : Feb. 3, 2010
(Tsun-Yu Shih/General Manager)

Contents

1	General Description	5
1.1	GENERAL DESCRIPTION OF EUT	5
1.2	TEST METHODOLOGY	5
1.3	REQUIREMENT FOR COMPLIANCE.....	6
1.4	THE SUPPORT UNITS	8
1.5	LAYOUT OF SETUP	8
1.6	TEST CAPABILITY	9
1.7	MEASUREMENT UNCERTAINTY	10
2	Field Strength of fundamental.....	11
2.1	APPLIED STANDARD	11
2.2	TEST INSTRUMENTS	11
2.3	MEASUREMENT PROCEDURE.....	12
2.4	TEST CONFIGURATION	12
2.5	TEST DATA	13
3	Radiated Emission	17
3.1	APPLIED STANDARD	17
3.2	TEST INSTRUMENTS	18
3.3	MEASUREMENT PROCEDURE.....	19
3.4	TEST CONFIGURATION	20
3.5	TEST DATA	21
4	Frequency Tolarence	25
4.1	APPLIED STANDARD	25
4.2	TEST INSTRUMENTS	25
4.3	MEASUREMENT PROCEDURE.....	26
4.4	TEST CONFIGURATION	26
4.5	TEST DATA	27
5	20dB Bandwidth	30
5.1	APPLIED STANDARD	30
5.2	TEST INSTRUMENTS	30
5.3	MEASUREMENT PROCEDURE.....	31
5.4	TEST CONFIGURATION	31
5.5	TEST DATA	32
6	Conducted Emission Measurement	33

6.1	LIMITS FOR EMISSION MEASUREMENT	33
6.2	TEST INSTRUMENTS	34
6.3	TEST PROCEDURES	35
6.4	TEST CONFIGURATIONS	36
6.5	TEST DATA.....	37

Attachment 1 – Photographs of the Test Configurations

Attachment 2 – External Photographs of EUT

Attachment 3 – Internal Photographs of EUT

1 General Description

1.1 General Description of EUT

Equipment under Test: Contactless Card Reader

Model No. : Mx8SERIES CR3

P/N : P090-XXX-XX-R

Power in : 12Vdc

Test Voltage : 120Vac/ 50Hz to the adapter

Manufacturer : Sanmina-SCI Systems (Kunshan) Co.,Ltd.
WONG'S ELECTRONICS Co., Ltd

Channel Numbers : 1

Frequency Range : 13.56MHz

Function Modulation : ASK

Function Description :

The EUT is used to transmit and receive signal both. Please refer to the user's manual for the details.

1.2 Test Methodology

For this E.U.T., the radiated emissions and conducted emission measurement performed according to the procedures illustrated in ANSI C63.4:2003 and other required were illustrated in separate sections of this test report for detail.

1.3 Requirement for Compliance

(1) Field strength of Fundametal

According to 15.225(a), the field strength of any emissions within the band 13.553 - 13.567 MHz shall not exceed 15,848 microvolts/meter at 30 meters.

(2) Band Edge

According to 15.225(b), Within the bands 13.410-13.553 MHz and 13.567-13.710 MHz, the field strength of any emissions shall not exceed 334 microvolts/meter at 30 meters. According to 15.225(c), Within the bands 13.110-13.410 MHz and 13.710-14.010 MHz the field strength of any emissions shall not exceed 106 microvolts/meter at 30 meters.

(3) Radiation emission

According to 15.225(d), the field strength of any emissions appearing outside of the 13.110-14.010 MHz band shall not exceed the general radiated emission limits in § 15.209.

(4) Frequency tolerance

The frequency tolerance of the carrier signal shall be maintained within +/- 0.01% of the operating frequency over a temperature variation of -20 degrees to +50 degrees C at normal supply voltage, and for a variation in the primary supply voltage from 85% to 115% of the rated supply voltage at a temperature of 20 degrees C. For battery operated equipment, the equipment tests shall be performed using a new battery.

(5) Radiated emission limits, general requirements.

According to 15.209, except as provided elsewhere in this Subpart, the emissions from an intentional radiator shall not exceed the field strength levels specified in the following table:

Frequency (MHz)	Field Strength (uV/m)	Measurement Distance (m)
0.009 - 0.490	2400/F(kHz)	300
0.490 - 1.705	24000/F(kHz)	30
1.705 - 30.0	30	30
30 - 88	100 **	3
88 - 216	150 **	3
216 - 960	200 **	3
Above 960	500	3

** Except as provided in paragraph (g), fundamental emissions from intentional radiators operating under this Section shall not be located in the frequency bands 54-72 MHz, 76-88 MHz, 174-216 MHz or 470-806 MHz. However, operation within these frequency bands is permitted under other sections of this Part, e.g., Sections 15.231 and 15.241.

(6) 20dB Bandwidth

According to 15.215(c) requires the device must be designed to ensure that the 20 dB bandwidth of the emission, or whatever bandwidth may otherwise be specified in the specific rule section under which the equipment operates.

(7) Restricted Band

Frequency (MHz)	Frequency (MHz)	Frequency (MHz)	Frequency (GHz)
0.090 - 0.110	16.42 - 16.423	399.9 - 410	4.5 - 5.15
¹ 0.495 - 0.505	16.69475 - 16.69525	608 - 614	5.35 - 5.46
² 1735 - 2.1905	16.80425 - 16.80475	960 - 1240	7.25 - 7.75
4.125 - 4.128	25.5 - 25.67	1300 - 1427	8.025 - 8.5
4.17725 - 4.17775	37.5 - 38.25	1435 - 1626.5	9.0 - 9.2
4.20725 - 4.20775	73 - 74.6	1645.5 - 1646.5	9.3 - 9.5
6.215 - 6.218	74.8 - 75.2	1660 - 1710	10.6 - 12.7
6.26775 - 6.26825	108 - 121.94	1718.8 - 1722.2	13.25 - 13.4
6.31175 - 6.31225	123 - 138	2200 - 2300	14.47 - 14.5
8.291 - 8.294	149.9 - 150.05	2310 - 2390	15.35 - 16.2
8.362 - 8.366	156.52475 - 156.52525	2483.5 - 2500	17.7 - 21.4
8.37625 - 8.38675	156.7 - 156.9	2690 - 2900	22.01 - 23.12
8.41425 - 8.41475	162.0125 - 167.17	3260 - 3267	23.6 - 24.0
12.29 - 12.293	167.72 - 173.2	3332 - 3339	31.2 - 31.8
12.51975 - 12.52025	240 - 285	3345.8 - 3358	36.43 - 36.5
12.57675 - 12.57725	322 - 335.4	3600 - 4400	(2)
13.36 - 13.41			

¹ Until February 1, 1999, this restricted band shall be 0.490-0.510 MHz.

² Above 38.6

1.4 The Support Units

No.	Unit	Model No./ Serial No.	FCC ID	Trade Name	Power Cord	Supported by lab.
N/A	*	*	*	*	*	*

1.5 Layout of Setup



Connecting Cables

No.	Cable	Length	Shielded	Core	Shielded Backshell	Supported by lab.	Note
N/A	*	*	*	*	*	*	*

Justification:

For both conducted and radiated emission below 1GHz, the system was configured for typical fashion as a customer could use it normally.

For radiated emission, measurement of radiated emission from digital circuit is performed with normal transmitting.

1.6 Test Capability

Test Facility

The test facility used for evaluating the conformance of the EUT with each standard in the present report meets what required in CISPR16-1-4, CISPR16-2-3 and ANSI C63.4.

Test Room	Type of Test Room	Descriptions
TR1	10m semi-anechoic chamber (23m×14m×9m)	Complying with the NSA requirements in documents CISPR 22 and ANSI C63.4. For the radiated emission measurement.
TR10	3m semi-anechoic chamber (9m × 6m × 6m)	
TR11	3m semi-anechoic chamber (9m × 6m × 6m)	
TR300	3m fully-anechoic chamber (8m × 5m × 5m)	
TR13	Test site	For the RF conducted emission measurement.
TR5	Shielding Room (8m×5m×4m)	For the conducted emission measurement.

Test Laboratory Competence Information

Central Research Technology Co. has been accredited/registered/authorized by the agencies listed in the following table.

Certificate	Nation	Agency	Code	Mark
Accreditation Certificate	USA	NVLAP	200575-0	ISO/IEC 17025
	R.O.C. (Taiwan)	TAF	0905	ISO/IEC 17025
	R.O.C. (Taiwan)	BSMI	SL2-IN-E-0033, SL2-IS-E-0033, SL2-R1/R2-E-0033, SL2-A1-E-0033	ISO/IEC 17025
Site Filing Document	USA	FCC	474046, TW1053	Test facility list & NSA Data
	Canada	IC	4699A-1,-3	Test facility list & NSA Data
	Japan	VCCI	R-1527,C-1609,T-131,T-1441, G-10	Test facility list & NSA Data
Authorization Certificate	Germany	TUV	10021687-2008	ISO/IEC 17025
	Norway	Nemko	ELA212	ISO/IEC 17025

The copy of each certificate can be downloaded from our web site: www.crc-lab.com

1.7 Measurement Uncertainty

The assessed measurement uncertainty with a suitable coverage factor K to ensure 95% confidence level for the normal distribution are shown as below, the values are less than U_{cispr} in table 1 of CISPR 16-4-2

Test Item	Measurement Uncertainty
Frequency error	4.2Hz
Radiated Emission: (30MHz~200MHz)	Horizontal: 2.8dB ; Vertical: 3.5dB
Radiated Emission: (200MHz~1GHz)	Horizontal: 3.4dB ; Vertical: 2.8dB

2 Field Strength of fundamental

Result: Pass

2.1 Applied Standard

According to 15.225(a), The field strength of any emissions within the band 13.553 - 13.567 MHz shall not exceed 15,848 microvolts/meter at 30 meters.

According to 15.225(b), Within the bands 13.410-13.553 MHz and 13.567-13.710 MHz, the field strength of any emissions shall not exceed 334 microvolts/meter at 30 meters.

According to 15.225(c), Within the bands 13.110-13.410 MHz and 13.710-14.010 MHz the field strength of any emissions shall not exceed 106 microvolts/meter at 30 meters.

2.2 Test Instruments

Test Site and Equipment	Manufacturer	Model No./ Serial No.	Last Calibration Date	Calibration Due Date
Test Receiver	R&S	ESCI/100019	2009/11/30	2010/11/29
Antenna	EMCO	6502/20558	2008/8/4	2011/8/3
Semi - anechoic Chamber	ETS. LINDGREN	TR11/ 906-A	2009/6/30	2010/6/29

Note:

1. The calibrations are traceable to NML/ROC.
2. The calibration date of the semi-anechoic chamber listed above is the date of NSA measurement.

Instrument Setting

RBW	VBW	Detector	Trace	Comment
9kHz	N/A	Quasi-Peak	Maxhold	

Climatic Condition

Ambient Temperature : 24°C; Relative Humidity : 55%

2.3 Measurement Procedure

- a. The EUT was set up per the test configuration figured in the next section of this chapter to simulate the typical usage per the user's manual.
- b. If the EUT is tabletop equipment, it was placed on a wooden table with a height of 0.8 meters above the reference ground plane in the semi-anechoic chamber. If the EUT is floor-standing equipment, it was placed on a non-conducted support with a height of 12 millimeters above the reference ground plane in the semi-anechoic chamber.
- c. The EUT was set 3m away from the interference receiving antenna.
- d. Rapidly sweep the signal in the test frequency range by using the spectrum through the Maximum-peak detector.
- e. Rotate the EUT from 0° to 360° and position the receiving loop antenna at 1~4 meters above the reference ground plane to determine the fundamental frequency and record them.
- f. Finely turn the turntable and the antenna is be positioned with its plane vertical at the specified distance from the EUT and rotated about its vertical axis for maximum response and recorded position of fundamental frequency found from step e.
- g. Record and compare the maximum level with the required limit.
- h. Change the receiving antenna to another polarization to measure Field Strength of fundamental by following step e. to g. again.

2.4 Test Configuration

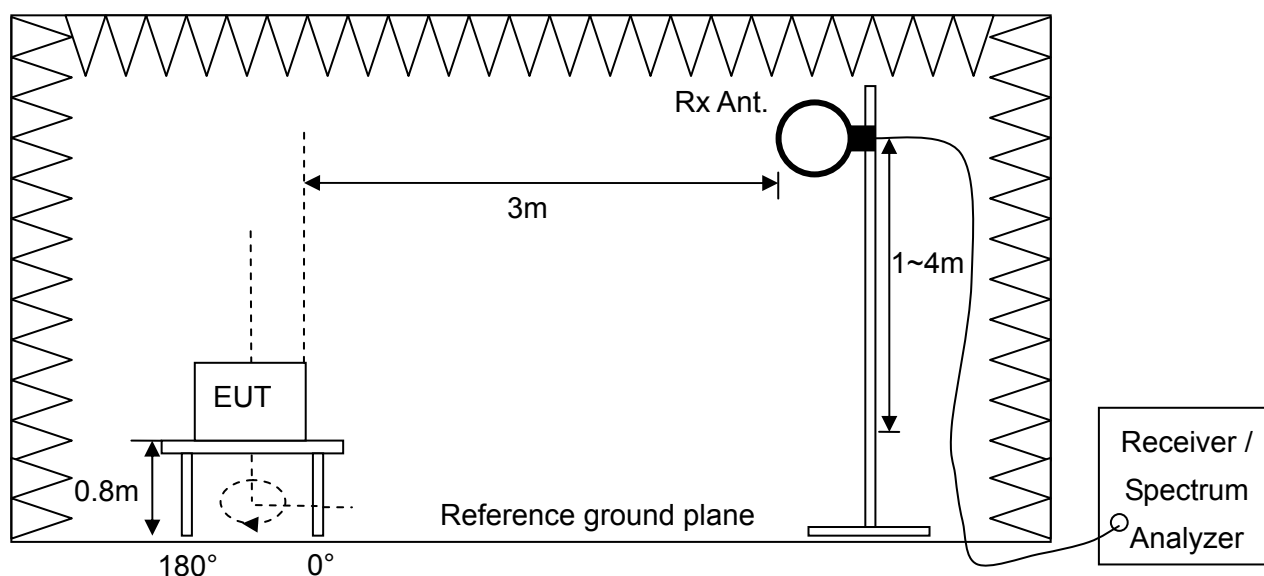

2.5 Test Data

Field strength of fundamental

Test Mode : Continuous Transmitting

Test Distance : 3m Tester : Jacky

Freq. (MHz)	Polarization	Reading Data (dBuV)	Correction Factor (dB/m)	Emission Level (dBuV/m)	Limit (dBuV/m)	Margin (dB)
13.56	V	54.70	13.97	69.60	124	54.40
13.56	H	54.07	13.97	57.68	124	66.32

Note :

1. Correction Factor (dB/m) = Cable Loss + Antenna Factor
2. Output Field Strength (dBuV/m) = Reading Data + Correction Factor
3. The limit is 15848 (uV/m)=84dBuV/m @ 30 m , for main frequency < 30MHz, the formula transfers the limit at 30 m to 3m is $L_{30}(\text{dBuV/m}) + 40 = 124 \text{ dBuV/m}$
4. Margin (dB) = Limit – Output Field Strength

V Polarization

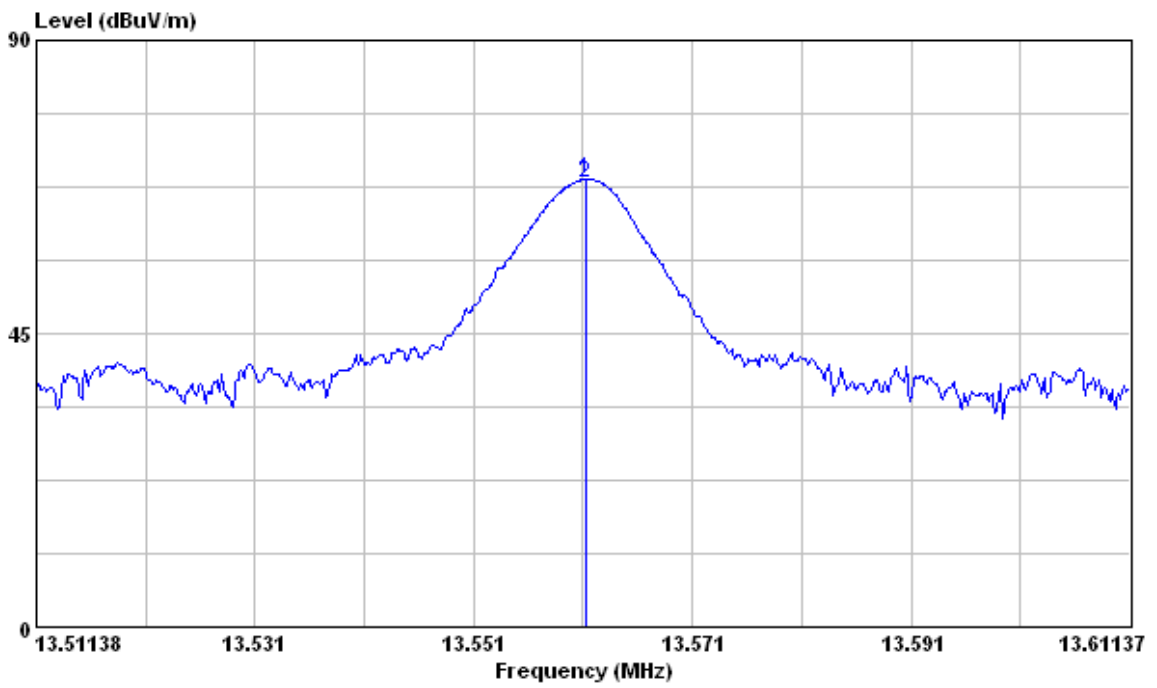

H Polarization

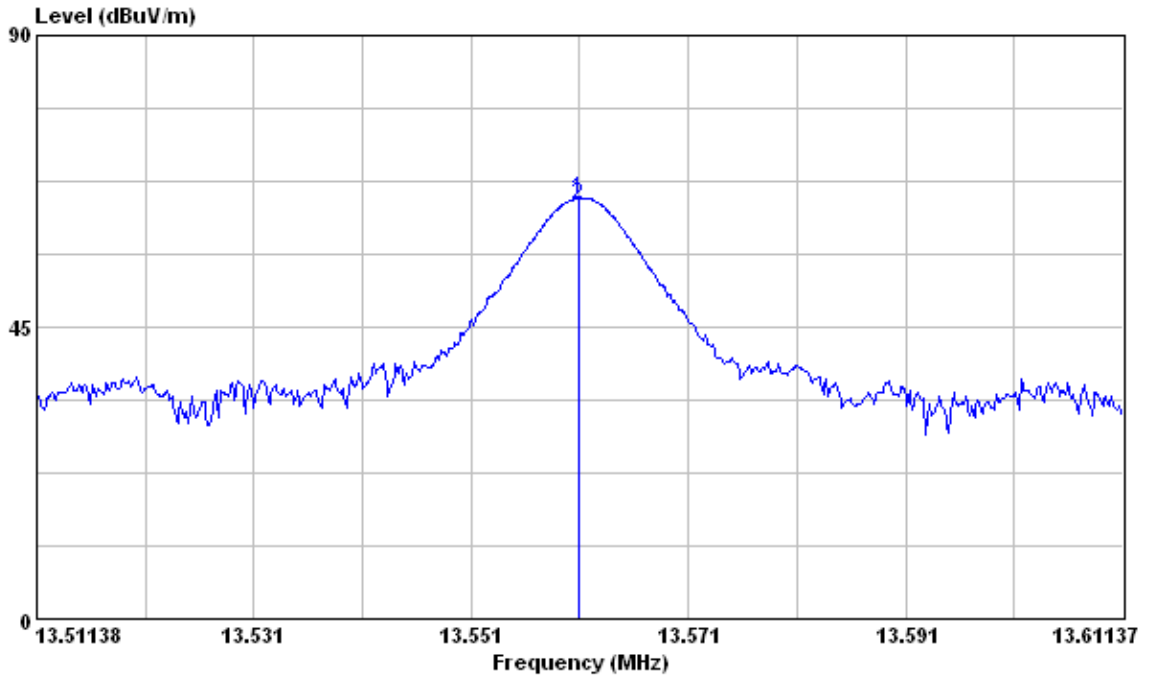

Band Edge

Test Mode : Continuous Transmitting

Test Distance : 3m Tester : Jacky

Emission Freq. (MHz)	Polarizortal	Reading Data (dBuV)	Correction Factor (dB/m)	Maximum Emission within the band (dBuV/m)	Limit (dBuV/m)	Margin (dB)
13.490	V	32.56	13.97	46.53	90.47	43.94
13.500	H	29.66	13.97	43.63	90.47	46.84
13.630	V	31.26	13.96	45.22	90.47	45.25
13.640	H	28.33	13.96	42.29	90.47	48.18
13.350	V	28.86	13.98	42.84	80.51	37.67
13.350	H	27.49	13.98	41.47	80.51	39.04
13.770	V	28.54	13.97	42.51	80.51	38
13.780	H	25.75	13.97	39.72	80.51	40.79

Note :

1. Correction Factor (dB/m) = Cable Loss + Antenna Factor
2. Output Field Strength (dBuV/m) = Reading Data + Correction Factor
3. For main frequency < 30MHz, the formula transfers the limit at 30 m to 3m is $L_{30}(\text{dBuV/m}) + 40$
4. Margin (dB) = Limit – Output Field Strength

V Polarization

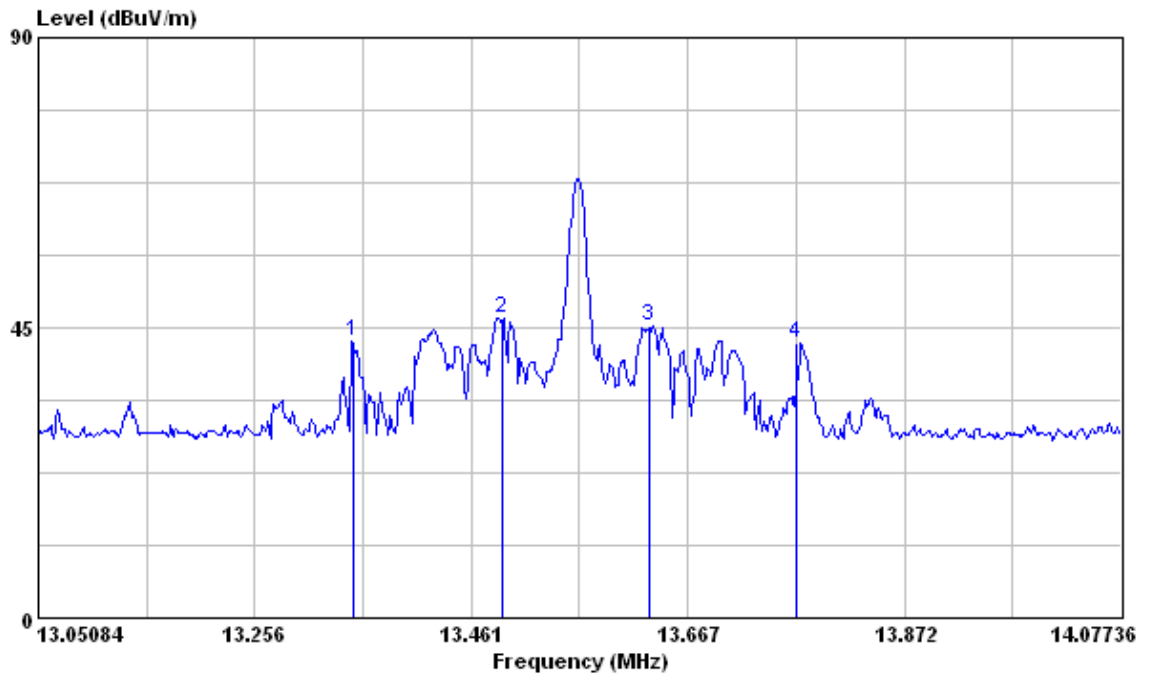

H Polarization

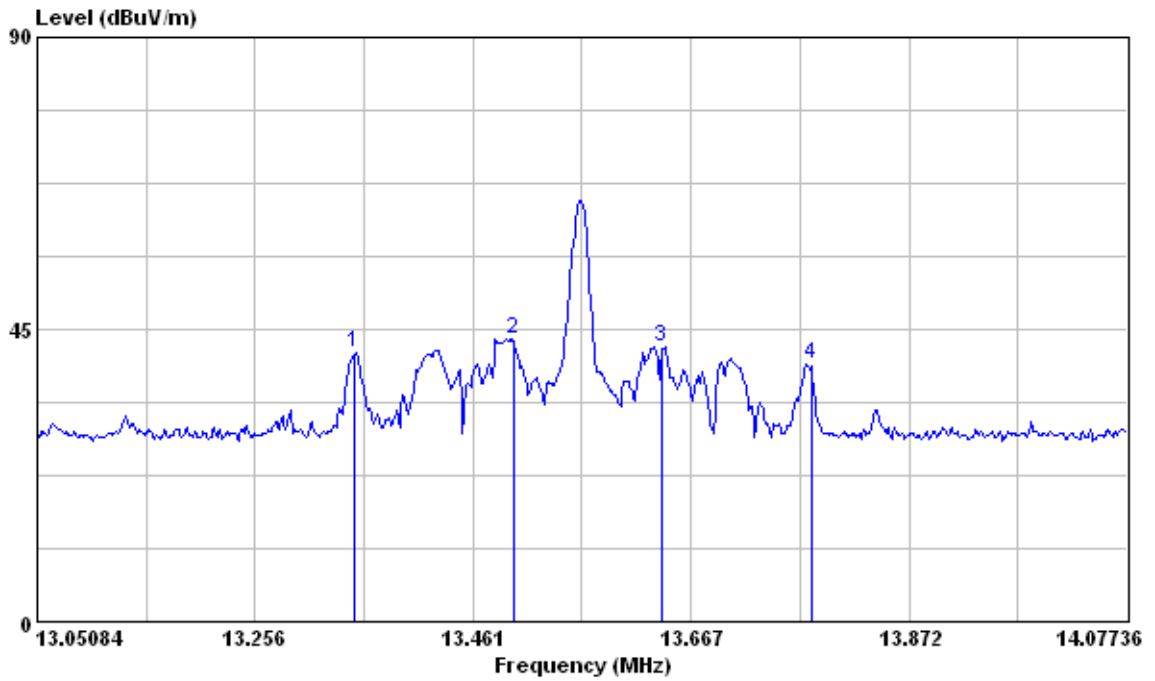

3 Radiated Emission

Result: Pass

3.1 Applied Standard

According to 15.225(d), The field strength of any emissions appearing outside of the 13.110-14.010 MHz band shall not exceed the general radiated emission limits in § 15.209.

Frequency (MHz)	Field Strength (uV/m)	Measurement Distance (m)
0.009 - 0.490	2400/F(kHz)	300
0.490 - 1.705	24000/F(kHz)	30
1.705 - 30.0	30	30
30 - 88	100 **	3
88 - 216	150 **	3
216 - 960	200 **	3
Above 960	500	3

** Except as provided in paragraph (g), fundamental emissions from intentional radiators operating under this Section shall not be located in the frequency bands 54-72 MHz, 76-88 MHz, 174-216 MHz or 470-806 MHz. However, operation within these frequency bands is permitted under other sections of this Part, e.g., Sections 15.231 and 15.241.

3.2 Test Instruments

Test Site and Equipment	Manufacturer	Model No./ Serial No.	Last Calibration Date	Calibration Due Date
Test Receiver	R&S	ESCI/100019	2009/11/30	2010/11/29
Spectrum Analyzer	Agilent	E4407B/ MY45106795	2009/3/19	2010/3/18
Antenna	EMCO	6502/20558	2008/8/4	2011/8/3
Broadband Antenna	EMCO	3142C/52088	2009/7/22	2010/7/21
Semi - anechoic Chamber	ETS. LINDGREN	TR11/ 906-A	2009/6/30	2010/6/29

Note:

1. The calibrations are traceable to NML/ROC.

Instrument Setting

RBW	VBW	Detector	Trace	Comment
9kHz	N/A	Quasi-Peak	Maxhold	Below 30MHz
120kHz	N/A	Quasi-Peak	Maxhold	Below 1GHz

Climatic Condition

Ambient Temperature : 24°C; Relative Humidity : 55%

3.3 Measurement Procedure

- a. The EUT was set up per the test configuration figured in the next section of this chapter to simulate the typical usage per the user's manual.
- b. A software provided by client enabled the EUT to transmit and receive data at specified channel frequencies individually.
- c. If the EUT is tabletop equipment, it was placed on a wooden table with a height of 0.8 meters above the reference ground plane in the semi-anechoic chamber. If the EUT is floor-standing equipment, it was placed on a non-conducted support with a height of 12 millimeters above the reference ground plane in the semi-anechoic chamber.
- d. The EUT was set 3m away from the interference receiving antenna.
- e. Rapidly sweep the signal in the test frequency range by using the spectrum through the Maximum-peak detector.
- f. Rotate the EUT from 0° to 360° and position the receiving antenna at heights from 1 to 4 meters above the reference ground plane continuously to determine at least six frequencies associated with higher emission levels and record them.
- g. Then measure each frequency found from step f. by using the spectrum with rotating the EUT and positioning the receiving antenna height to determine the maximum level.
- h. For measurement of frequency above 1000MHz, the beamwidth of receiving horn antenna should keep covering EUT when the receiving horn antenna height varied.
- i. For measurement of frequency above 1000MHz, set the spectrum analyzer to find out the maximum peak or average level occurred, if any.
- j. Record frequency, azimuth angle of the turntable, height, and polarization of the receiving antenna and compare the maximum level with the required limit.
- k. Change the receiving antenna to another polarization to measure radiated emission by following step e. to j. again.
- l. If the peak emission level below 1000MHz measured from step f. is 4dB lower than the limit specified, then the emission values presented will be the peak value only. Otherwise, accurate Q.P. value will be measured and presented.
- m. If the peak emission level above 1000MHz measured from step f. is 20dB lower than the limit specified, then the emission values presented will be the peak value only. Otherwise, accurate A.V. value will be measured and presented.

3.4 Test Configuration

Below 30MHz

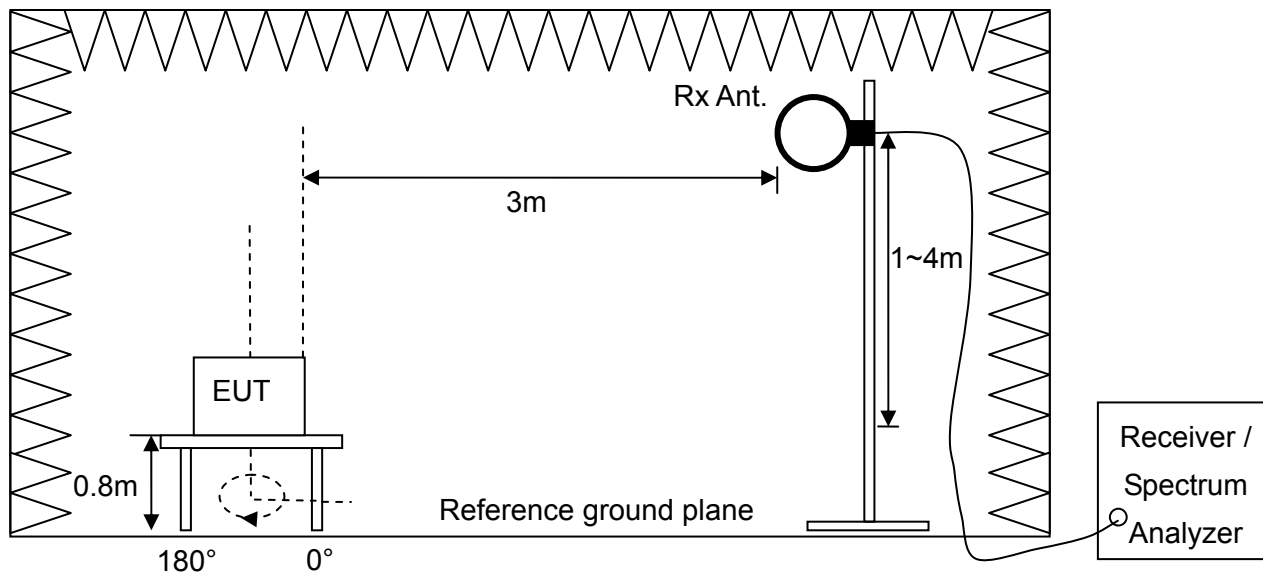

Above 30MHz

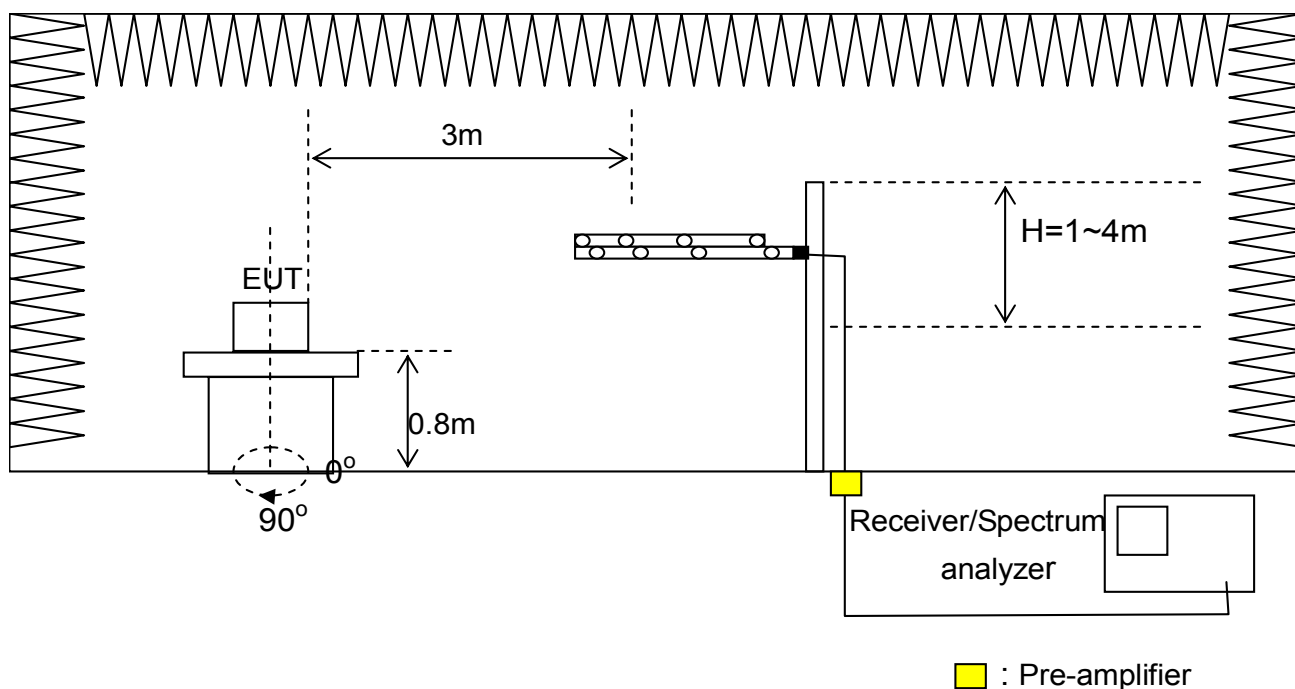

3.5 Test Data

Test Mode : Continuous Transmitting
 Test Distance : 3m Tester : Jacky
 Polarization : Vertical Frequency Range : 9kHz~30MHz

	Freq. (MHz)	Reading Data (dBuV)	Correction Factor (dB/m)	Emission Level (dBuV/m)	Limit (dBuV/m)	Margin (dB)
1	0.15	43.26	14.99	58.25	69.54	11.29
2	5.88	18.59	14.18	32.77	69.54	36.77
3	10.75	16.81	14.05	30.86	69.54	38.68
4	17.19	16.32	13.84	30.16	69.54	39.38
5	22.96	15.94	13.41	29.35	69.54	40.19
6	27.123	23.23	12.65	35.88	69.54	33.66

Note:

1. Correction Factor (dB/m) = Cable Loss + Antenna Factor
2. Emission Level (dBuV/m) = Reading Data + Correction Factor
3. Margin (dB) = Limit – Emission Level
4. For main frequency < 30MHz, the formula transfers the limit at 30 m to 3m is $L_{30}(\text{dBuV/m}) + 40$

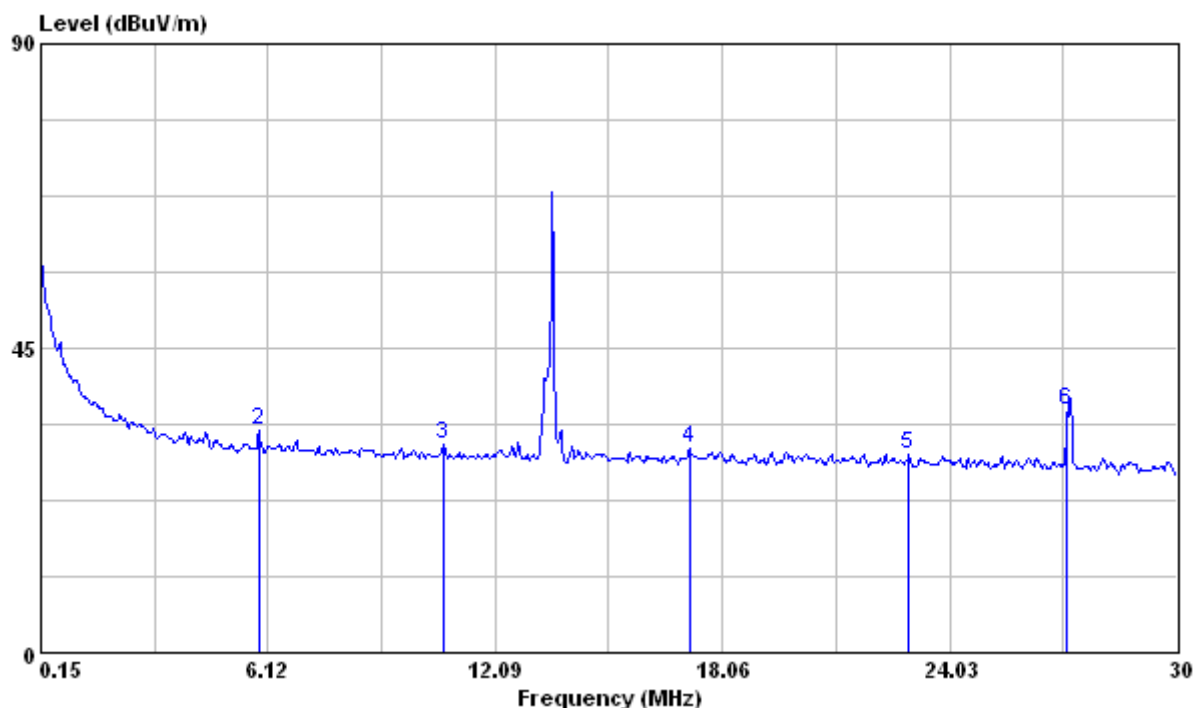

No signal can be detected from 9kHz to 150kHz, so the graphs are omitted below 150kHz.

Test Mode : Continuous Transmitting
Test Distance :3m **Tester** : Jacky
Polarization :Horizontal **Frequency Range** :9kHz~30MHz

	Freq. (MHz)	Reading Data (dBuV)	Correction Factor (dB/m)	Emission Level (dBuV/m)	Limit (dBuV/m)	Margin (dB)
1	0.209	39.18	14.86	54.04	69.54	15.5
2	3.43	18.67	14.29	32.96	69.54	36.58
3	11.94	17.46	14.01	31.47	69.54	38.07
4	18.75	17.13	13.79	30.92	69.54	38.62
5	24.96	16.04	13.18	29.22	69.54	40.32
6	27.22	22.90	12.62	35.52	69.54	34.02

Note:

1. Correction Factor (dB/m) = Cable Loss + Antenna Factor
2. Emission Level (dBuV/m) = Reading Data + Correction Factor
3. Margin (dB) = Limit – Emission Level
4. For main frequency < 30MHz, the formula transfers the limit at 30 m to 3m is $L_{30}(\text{dBuV/m}) + 40$

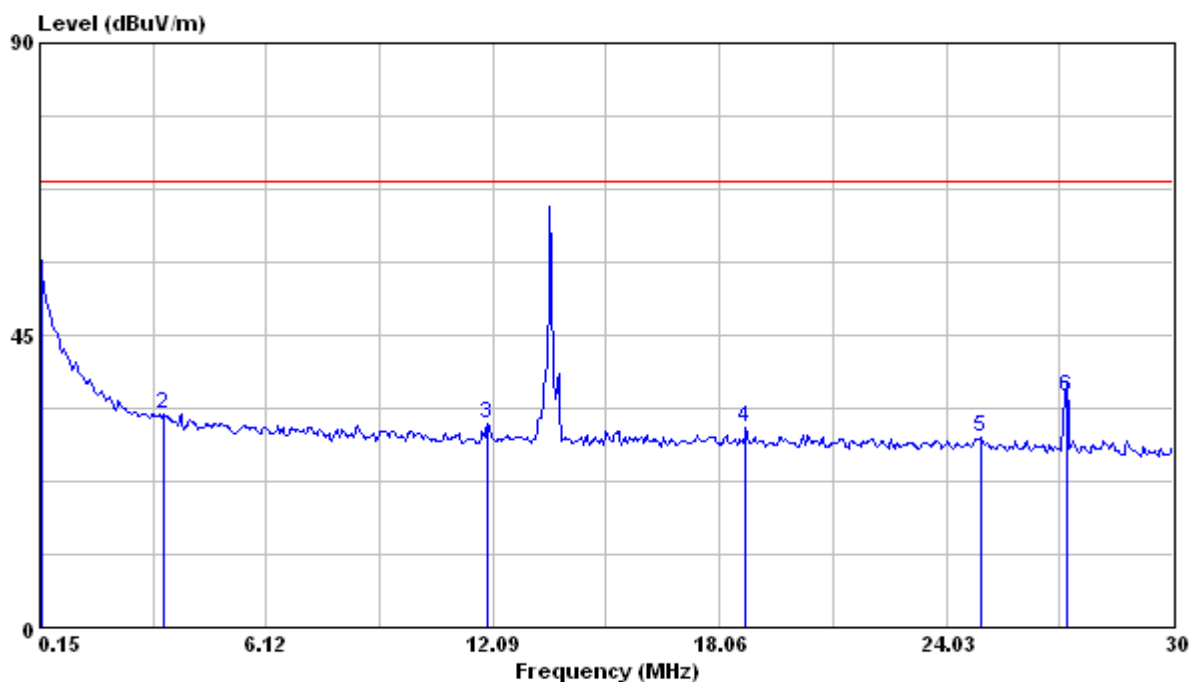

No signal can be detected from 9kHz to 150kHz, so the graphs are omitted below 150kHz.

Test Mode : Continuous Transmitting
 Test Distance : 3m Tester : Jacky
 Polarization : Vertical Frequency Range : 30MHz~1000MHz

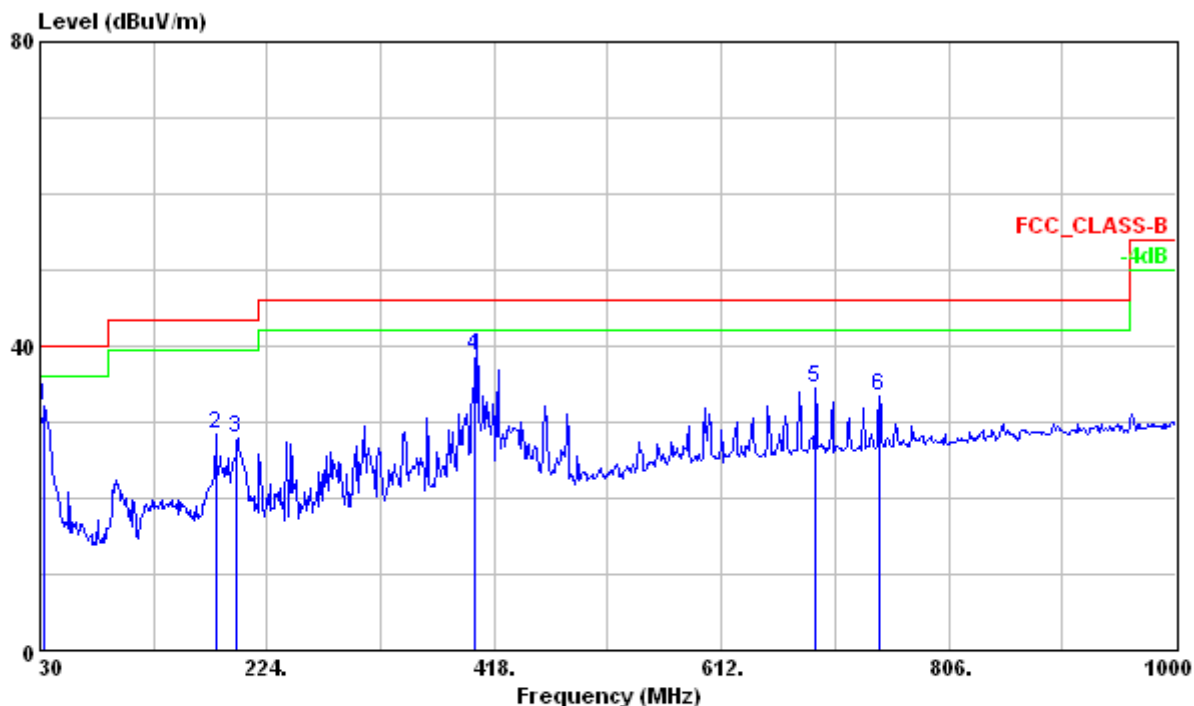

	Freq	Level	Read Level	Factor	Limit Line	Over Limit	Ant Pos	Table Pos	Pol/Phase	Remark
	MHz	dBuV/m	dBuV	dB/m	dBuV/m	dB	cm	deg		
1	33.780	32.00	43.06	-11.06	40.00	-8.00	---	---	VERTICAL	Peak
2	180.120	28.37	44.78	-16.41	43.50	-15.13	---	---	VERTICAL	Peak
3	198.210	28.01	43.93	-15.92	43.50	-15.49	---	---	VERTICAL	Peak
4	402.049	38.56	47.67	-9.11	46.00	-7.44	165	0	VERTICAL	QP
5	692.700	34.51	37.64	-3.13	46.00	-11.49	---	---	VERTICAL	Peak
6	746.600	33.35	36.07	-2.72	46.00	-12.65	---	---	VERTICAL	Peak

Note :

1. Correction Factor (dB/m) = Cable Loss + Antenna Factor – Gain of Preampifier
2. Emission Level (dBuV/m) = Reading Data + Correction Factor

Test Mode : Continuous Transmitting
 Test Distance :3m Tester : Jacky
 Polarization : Horizontal Frequency Range : 30MHz~1000MHz

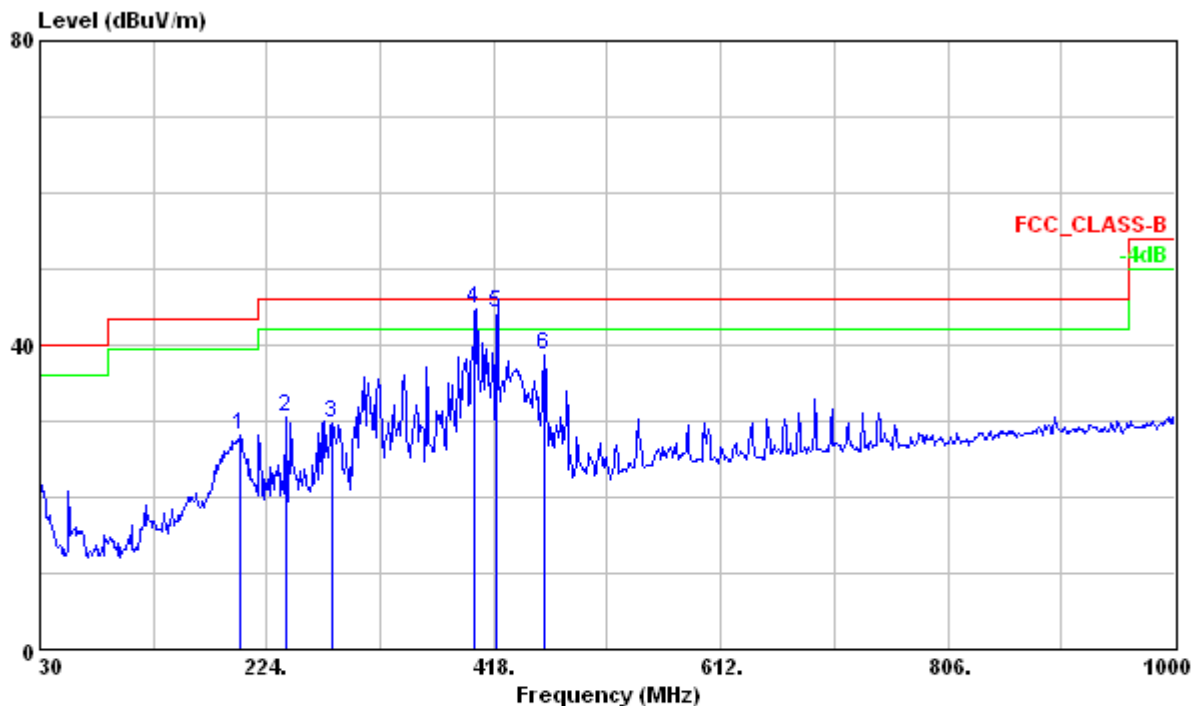

	Freq	Level	Read Level	Factor	Limit Line	Over Limit	Ant Pos	Table Pos	Pol/Phase	Remark
	MHz	dBuV/m	dBuV	dB/m	dBuV/m	dB	cm	deg		
1	200.370	28.20	44.03	-15.83	43.50	-15.30	---	---	HORIZONTAL	Peak
2	240.330	30.47	44.69	-14.22	46.00	-15.53	---	---	HORIZONTAL	Peak
3	279.480	29.61	42.58	-12.97	46.00	-16.39	---	---	HORIZONTAL	Peak
4 @	402.049	44.82	53.93	-9.11	46.00	-1.18	100	225	HORIZONTAL	QP
5 @	420.053	44.16	52.82	-8.66	46.00	-1.84	100	209	HORIZONTAL	QP
6 @	461.000	38.78	46.50	-7.72	46.00	-7.22	---	---	HORIZONTAL	Peak

Note :

1. Correction Factor (dB/m) = Cable Loss + Antenna Factor – Gain of Preamplifier
2. Emission Level (dBuV/m) = Reading Data + Correction Factor

4 Frequency Tolerance

Result: Pass

4.1 Applied Standard

According to 15.225(e), the frequency tolerance of the carrier signal shall be maintained within +/- 0.01% of the operating frequency over a temperature variation of -20 degrees to +50 degrees C at normal supply voltage, and for a variation in the primary supply voltage from 85% to 115% of the rated supply voltage at a temperature of 20 degrees C. For battery operated equipment, the equipment tests shall be performed using a new battery.

4.2 Test Instruments

Test Site and Equipment	Manufacturer	Model No./ Serial No.	Last Calibration Date	Calibration Due Date
Spectrum Analyzer	Agilent	E4405B/ MY45106706	2009/3/25	2010/3/24
Temperature Chamber	Terchy	MHG-800LF/ 920224	2009/8/17	2010/8/16
Adjustable AC Power Supply	EXTECH	6110/1102108	NCR	NCR
Test Site	N.A.	TR13	NCR	NCR

Note:

1. The calibrations are traceable to NML/ROC.
2. NCR : No Calibration Required.

Instrument Setting

RBW	VBW	Detector	Trace	Comment
300Hz	1kHz	Peak	Maxhold	

Climatic Condition

Ambient Temperature : 24°C; Relative Humidity : 55%

4.3 Measurement Procedure

- a. The EUT was set up per the test configuration figured in the next section of this chapter to simulate the typical usage described in the user's manual supported by the manufacturer in test site TR13.
- b. Measure the frequency tolerance by using the spectrum analyzer and following the test conditions described in FCC 15.225(e) to perform the normal and extreme conditions test.
- c. Record the value and compare with the required limit.

4.4 Test Configuration

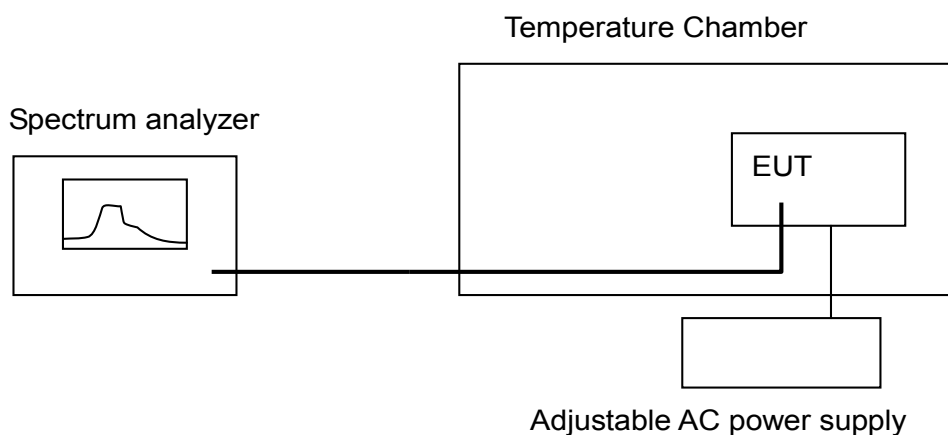

4.5 Test Data

Test Mode : Continuous Transmitting

Tester : Bill

Temperature (°C)	AC Voltage (Volt)	Meas. Frequency (MHz)	Deviation (kHz)	Limit (kHz)	Margin (kHz)
20°C	120	13.5613	NA	1.356	NA
	138	13.5613	0.00	1.356	1.356
	102	13.5613	0.00	1.356	1.356
-20°C	120	13.5614	0.10	1.356	1.256
50°C	120	13.5613	0.00	1.356	1.356

Note:

1. Deviation(kHz) = | Meas. Frequency – Meas. Frequency @20°C/120Vac |

2. Margin (kHz)= Limit – Deviation

20°C, 120Vac

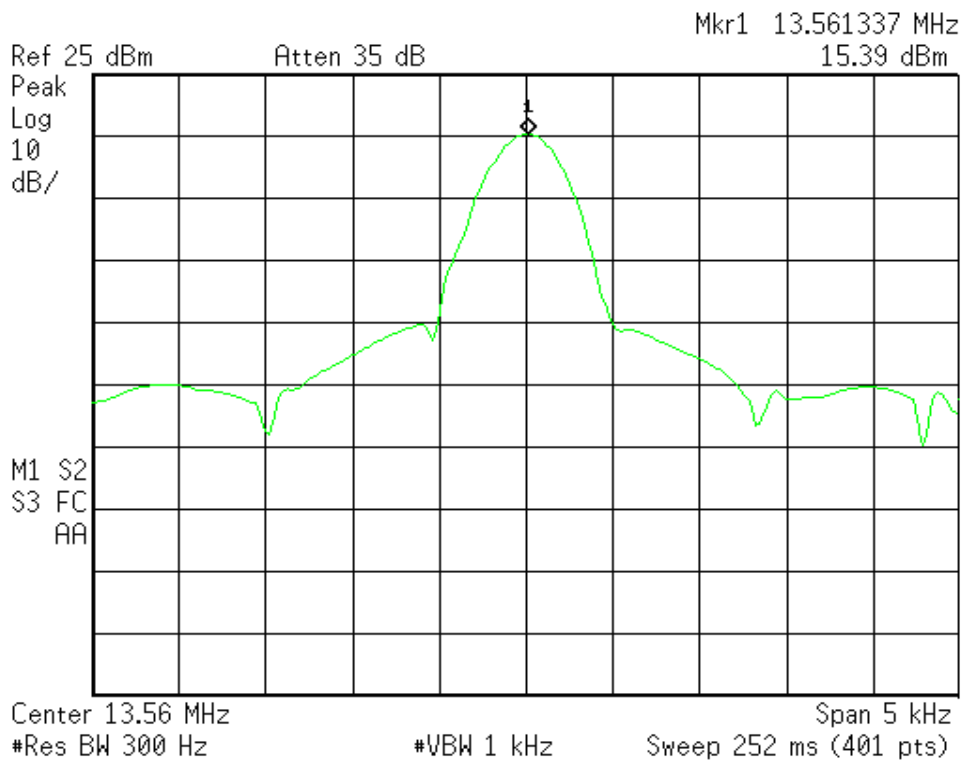

20°C, 138Vac

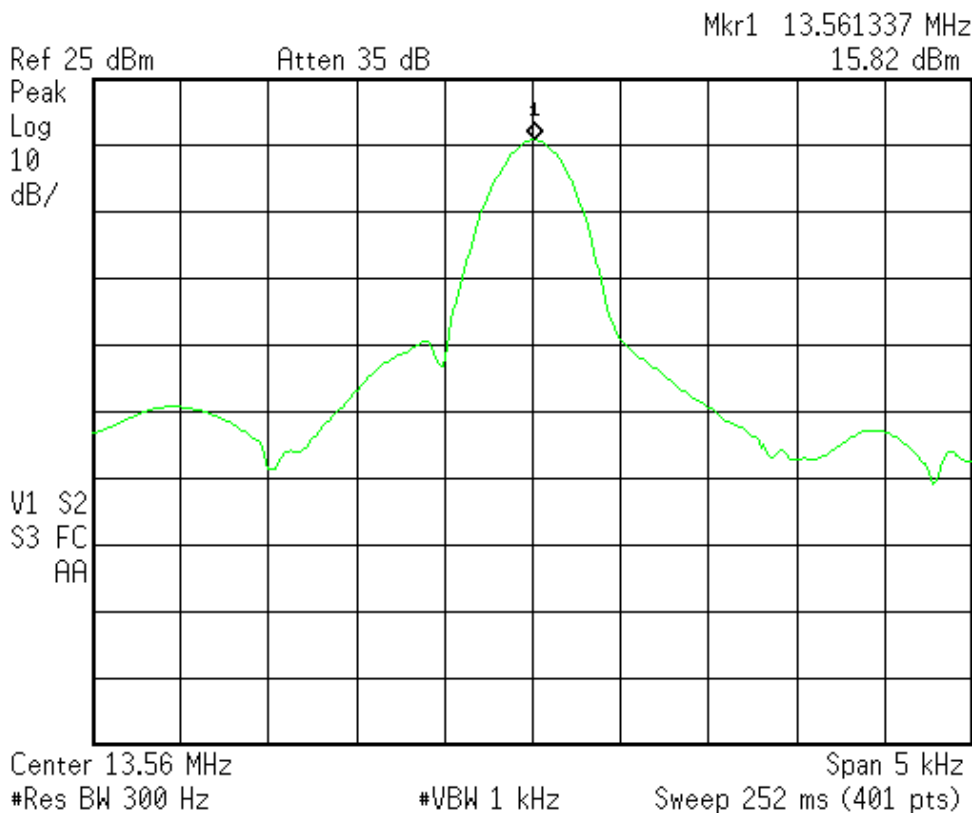

20°C, 102Vac

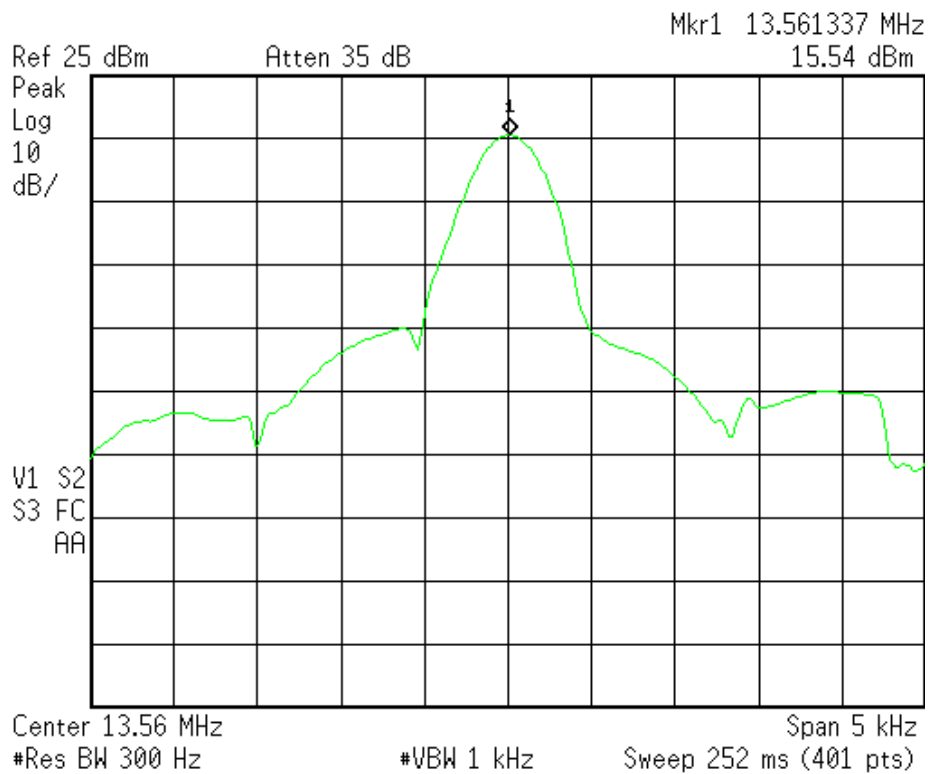

-20°C, 120Vac

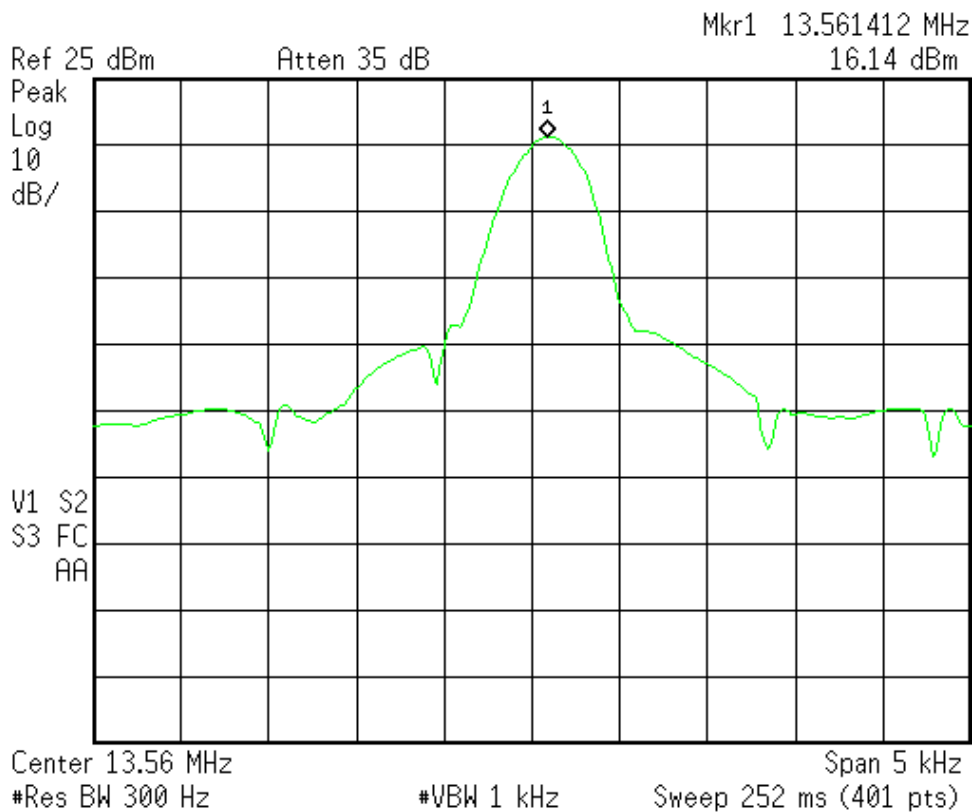

50°C, 120Vac

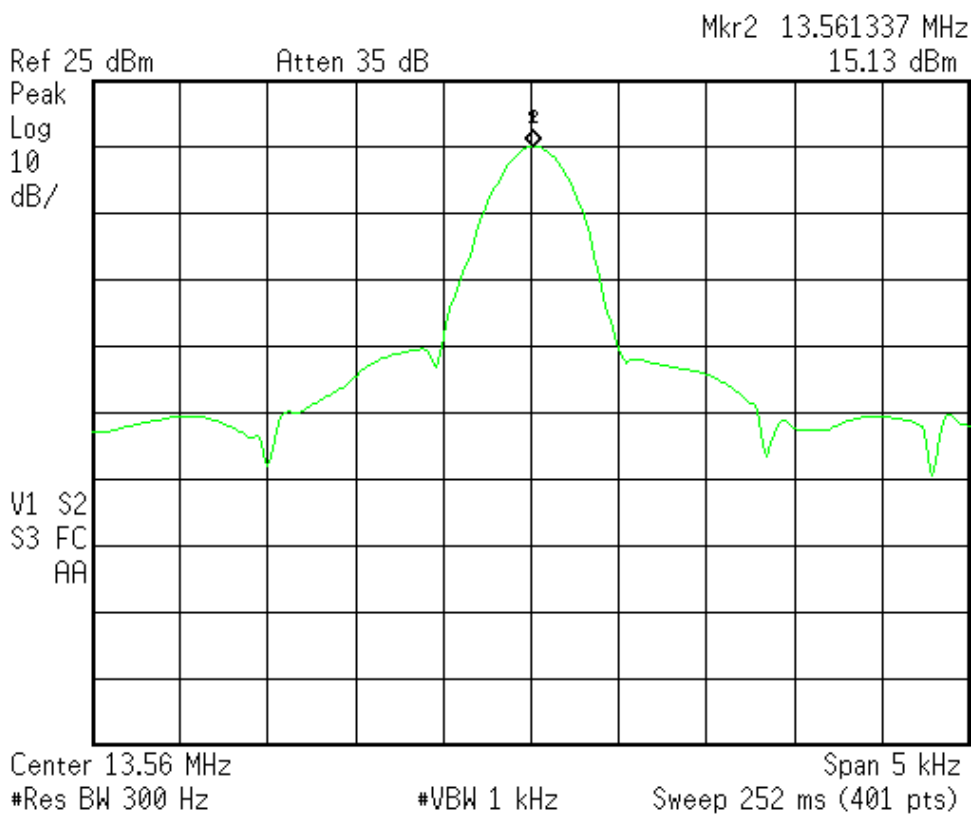

5 20dB Bandwidth

Result: Pass

5.1 Applied Standard

According to 15.215(c) requires the device must be designed to ensure that the 20 dB bandwidth of the emission, or whatever bandwidth may otherwise be specified in the specific rule section under which the equipment operates.

According to 15.225, Operation should within the band 13.110 – 14.010 MHz.

5.2 Test Instruments

Test Site and Equipment	Manufacturer	Model No./ Serial No.	Last Calibration Date	Calibration Due Data
Spectrum Analyzer	Agilent	E4405B/ MY45106706	2009/3/25	2010/3/24
Test Site	N.A.	TR13	NCR	NCR

Note:

1. The calibrations are traceable to NML/ROC.
2. NCR : No Calibration Required.

Instrument Setting

RBW	VBW	Detector	Trace	Comment
300Hz	1kHz	Sample	Maxhold	

Climatic Condition

Ambient Temperature : 24°C; Relative Humidity : 55%

5.3 Measurement Procedure

- a. The EUT was set up per the test configuration figured in the next section of this chapter to simulate the typical usage described in the user's manual supported by the manufacturer in test site TR13.
- b. Measure the 20dB bandwidth by using the spectrum analyzer and following the test conditions described in FCC 15.215.
- c. Record the frequency and compare with the required limit.

5.4 Test Configuration



5.5 Test Data

Test Mode : Continuous Transmitting

Tester : Bill

Operating Frequency (MHz)	The lowest frequency (MHz)	The highest frequency (MHz)	Limit (MHz)
13.56	13.5610	13.5616	13.110~14.01

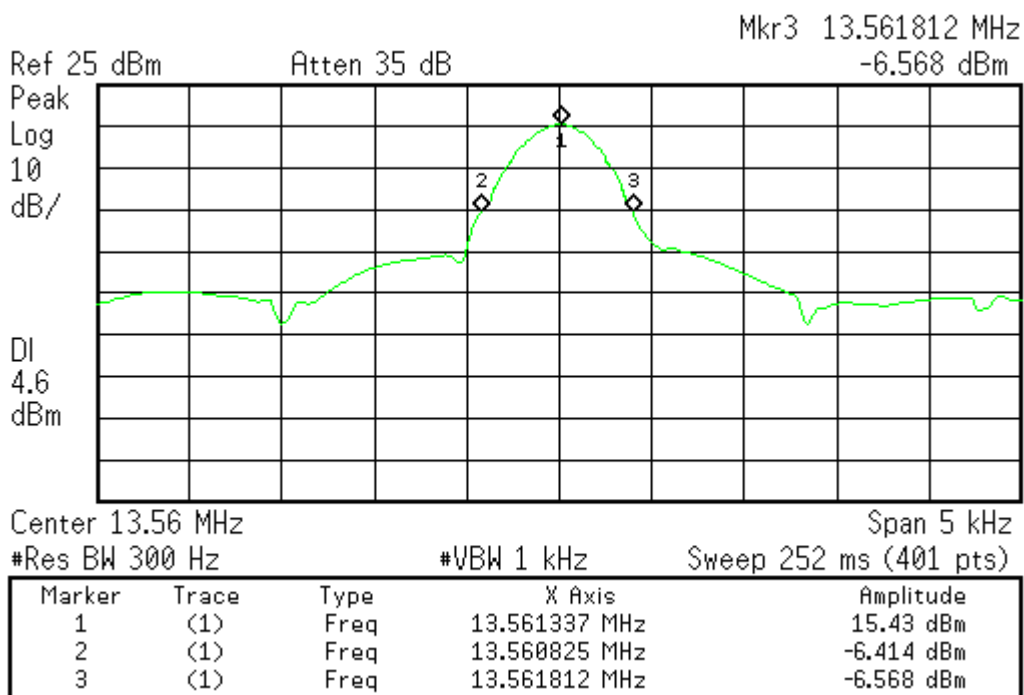

6 Conducted Emission Measurement

Test Data: Pass

6.1 Limits for Emission Measurement

For intentional device, according to §15.207(a) line conduction emission limit is as below table.

Frequency of Emission (MHz)	Conducted Limit (dBuV)	
	Quasi-peak	Average
0.15 – 0.5	66 to 56*	56 to 46*
0.5 - 5	56	46
5 - 30	60	50

* Decreases with the logarithm of the frequency.

Note:

For a device with a permanent antenna operating at or below 30 MHz, the FCC will accept measurements done with a suitable dummy load, in lieu of the permanent antenna under the following conditions: (1) perform the AC line conducted tests with the permanent antenna to determine compliance with the Section 15.207 limits outside the transmitter's fundamental emission band; (2) retest with a dummy load in lieu of the permanent antenna to determine compliance with the Section 15.207 limits within the transmitter's fundamental emission band.

6.2 Test Instruments

Test Site and Equipment	Manufacturer	Model No./ Serial No.	Last Calibration Date	Calibration Due Date
Test Receiver	R&S	ESCS 30/ 836858/021	2009/1/13	2010/1/12
LISN	R&S	ESH2-Z5/ 836613/001	2009/8/14	2010/8/13
2 nd LISN	R&S	ENV4200/ 833209/010	2009/1/13	2010/1/12
50Ω terminator	N/A	N/A/ 001	2009/8/26	2010/8/25
RF Switch	N/A	RSU28/ 338965/002	2009/3/3	2010/3/2
RF Cable	N/A	N/A/ C0052 ~ 56	2009/3/3	2010/3/2
Test Software	Audix	e3/ Ver. 5.4.219.f	NCR	NCR
TR5 shielded room	ETS LINDGREN	TR5/ 15353-F	NCR	NCR

Note:

1. The calibrations are traceable to NML/ROC.
2. NCR : No Calibration Required.

Instrument Setting

IF BW	Measurement Time	Detector	Trace	Comment
9kHz	1 second	Quasi-Peak / Average	Maxhold	

Climatic Condition

Ambient Temperature : 27°C; Relative Humidity : 65%

6.3 Test Procedures

- a. The EUT was set up per the test configuration figured in the next section of this chapter to simulate the typical usage per the user's manual.
- b. If the EUT is tabletop equipment, it was placed on a non-conducted table with a height of 0.8 meters above the reference ground plane and 0.4 meters from the conducting wall of the shielded room. Also if the EUT is floor-standing equipment, it was placed on a non-conducted support with a height of 12 millimeters above the reference ground plane.
- c. Connect the EUT's power source to the appropriate power mains through the LISN.
- d. All the other peripherals are connected to the 2nd LISN, if any.
- e. The LISN was placed 0.8 meters from the EUT and at least 0.8 meters from other units and other metal planes.
- f. Measure the conducted emissions on each power line (Neutral Line and Line 1 – Hot side) of the EUT's power source by using the test receiver connected to the coupling RF output port of LISN.
- g. Rapidly scan the signal from 150kHz to 30MHz by using the receiver through the Maximum-Peak detector to determine those frequencies associated with higher emission levels for each measured line.
- h. Then measure the maximum level of conducted disturbance for each frequency found from step g. by using the receiver through the Quasi-Peak and Average detectors per CISPR 16-1.
- i. Record the level for each frequency and compare with the required limit.

6.4 Test Configurations

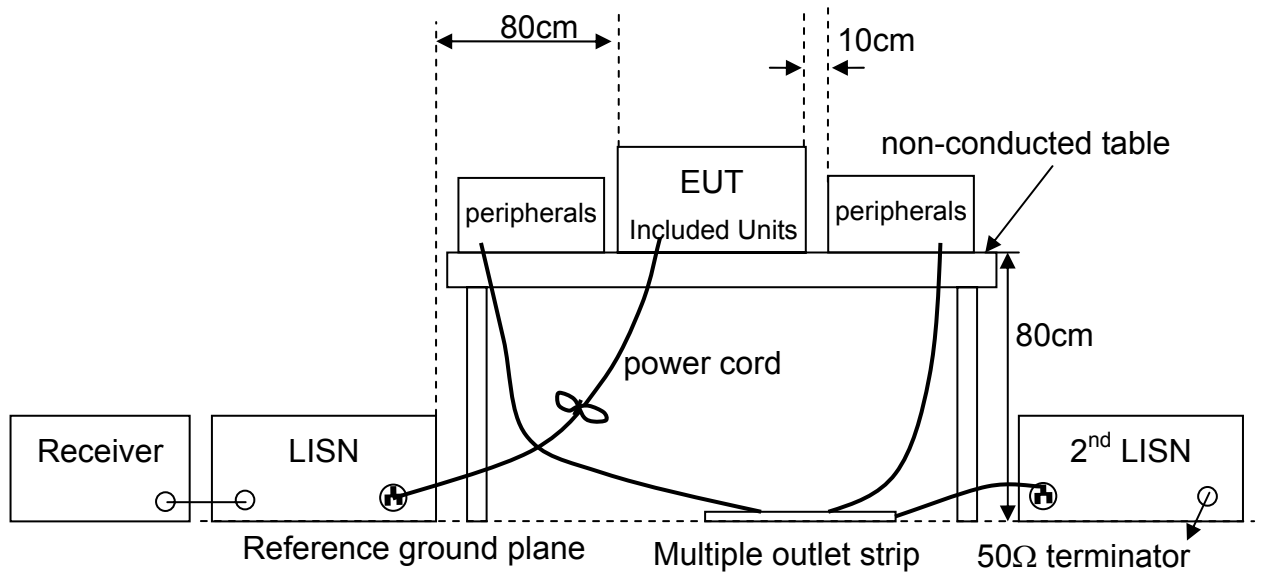

6.5 Test Data

Test Mode : Continuous Transmitting, with antenna
 Tester : CDC Frequency Range : 150kHz~30MHz
 Phase : Line

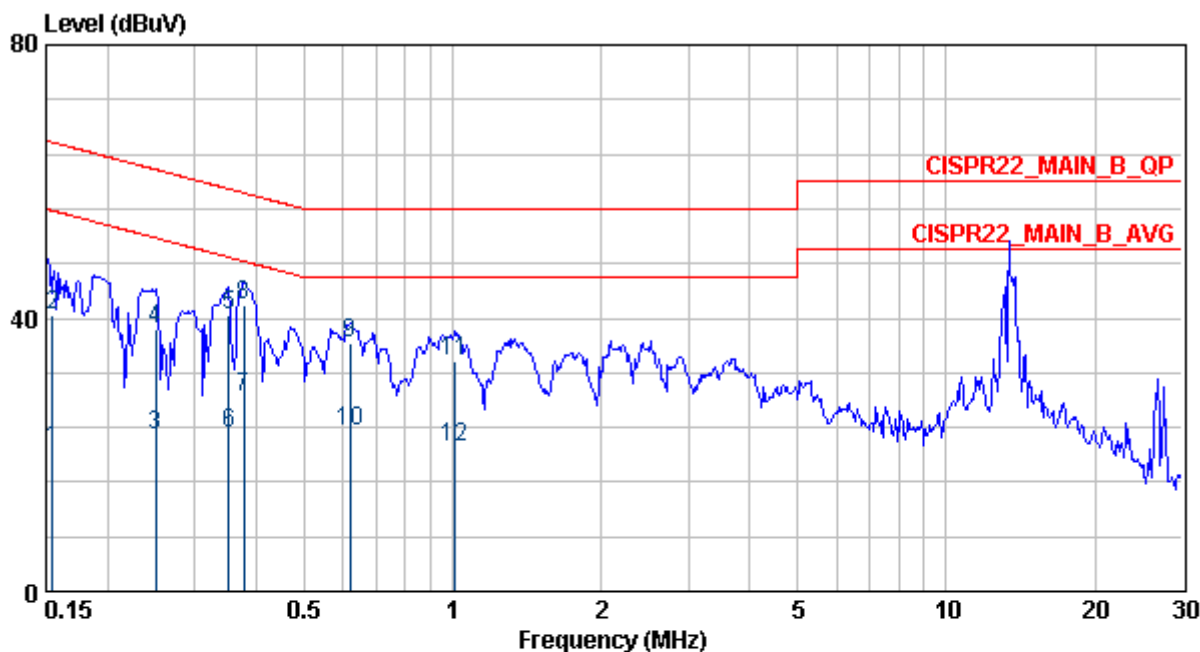

	Freq	Level	Factor	Read Level	Limit Line	Over Limit	Ant Pos	Pol/Phase	Remark
	MHz	dBuV	dB	dBuV	dBuV	dB	cm		
1	0.15	20.79	0.18	20.61	55.75	-34.96	---	LINE	AVERAGE
2	0.15	40.32	0.18	40.14	65.75	-25.44	---	LINE	QP
3	0.25	22.80	0.20	22.60	51.73	-28.93	---	LINE	AVERAGE
4	0.25	38.32	0.20	38.11	61.73	-23.41	---	LINE	QP
5	0.35	40.45	0.21	40.24	58.91	-18.47	---	LINE	QP
6	0.35	23.01	0.21	22.81	48.91	-25.90	---	LINE	AVERAGE
7	0.38	28.34	0.21	28.13	48.34	-20.00	---	LINE	AVERAGE
8 @	0.38	41.95	0.21	41.74	58.34	-16.40	---	LINE	QP
9	0.62	36.26	0.26	36.00	56.00	-19.74	---	LINE	QP
10	0.62	23.30	0.26	23.04	46.00	-22.70	---	LINE	AVERAGE
11	1.01	33.82	0.31	33.51	56.00	-22.18	---	LINE	QP
12	1.01	21.08	0.31	20.77	46.00	-24.92	---	LINE	AVERAGE

Note:

1. Emission Level = reading value + correction factor.
2. Correction factor = cable loss + insertion loss of LISN.
3. Q.P. is abbreviation of quasi-peak.

Tx Fundamental, for reference only. Please refer to next page.

Test Mode : Continuous Transmitting, with dummy load
 Tester : CDC Frequency Range : 150kHz~30MHz
 Phase : Line

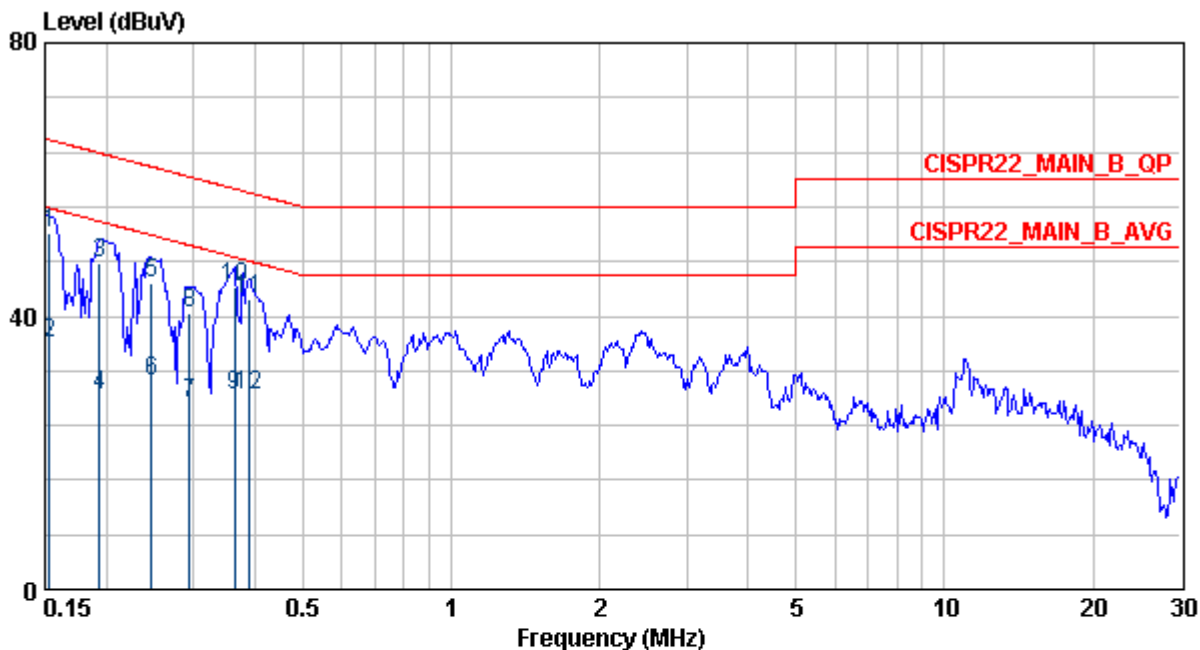

	Freq	Level	Factor	Read Level	Limit Line	Over Limit	Ant Pos	Pol/Phase	Remark
	MHz	dBuV	dB	dBuV	dBuV	dB	cm		
1	0.15	52.31	0.18	52.13	65.82	-13.52	---	LINE	QP
2	0.15	36.08	0.18	35.89	55.82	-19.75	---	LINE	AVERAGE
3	0.19	47.72	0.20	47.53	63.89	-16.16	---	LINE	QP
4	0.19	28.29	0.20	28.10	53.89	-25.59	---	LINE	AVERAGE
5	0.25	44.86	0.20	44.65	61.86	-17.01	---	LINE	QP
6	0.25	30.43	0.20	30.23	51.86	-21.43	---	LINE	AVERAGE
7	0.29	27.22	0.21	27.01	50.41	-23.19	---	LINE	AVERAGE
8	0.29	40.41	0.21	40.20	60.41	-20.00	---	LINE	QP
9	0.36	28.46	0.21	28.25	48.65	-20.19	---	LINE	AVERAGE
10	0.36	44.20	0.21	43.99	58.65	-14.45	---	LINE	QP
11	0.39	42.52	0.21	42.31	58.08	-15.55	---	LINE	QP
12	0.39	28.32	0.21	28.11	48.08	-19.76	---	LINE	AVERAGE

Note:

1. Emission Level = reading value + correction factor.
2. Correction factor = cable loss + insertion loss of LISN.
3. Q.P. is abbreviation of quasi-peak.

Test Mode : Continuous Transmitting, with antenna
 Tester : CDC Frequency Range : 150kHz~30MHz
 Phase : Neutral

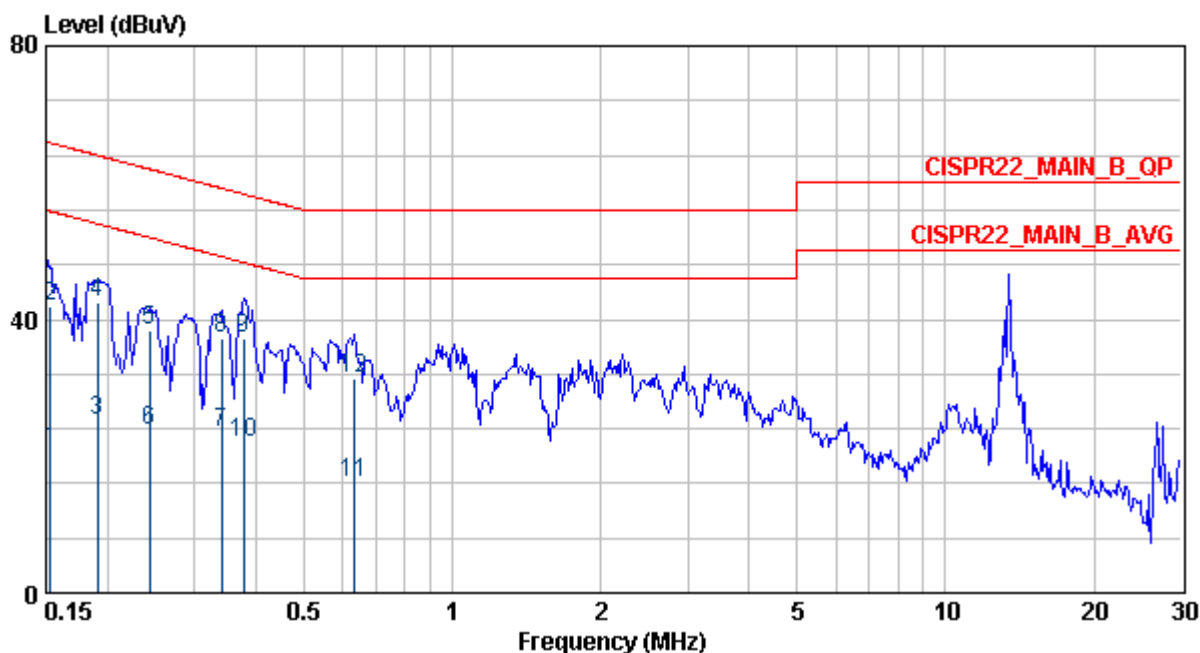

	Freq	Level	Factor	Read Level	Limit Line	Over Limit	Ant Pos	Pol/Phase	Remark
	MHz	dBuV	dB	dBuV	dBuV	dB	cm		
1	0.15	20.91	0.19	20.72	55.83	-34.92	---	NEUTRAL	AVERAGE
2	0.15	41.76	0.19	41.57	65.83	-24.07	---	NEUTRAL	QP
3	0.19	25.14	0.20	24.94	54.02	-28.88	---	NEUTRAL	AVERAGE
4	0.19	42.47	0.20	42.27	64.02	-21.55	---	NEUTRAL	QP
5	0.24	38.40	0.21	38.20	62.00	-23.59	---	NEUTRAL	QP
6	0.24	23.64	0.21	23.44	52.00	-28.35	---	NEUTRAL	AVERAGE
7	0.34	23.55	0.22	23.34	49.18	-25.63	---	NEUTRAL	AVERAGE
8	0.34	37.11	0.22	36.90	59.18	-22.07	---	NEUTRAL	QP
9	0.38	37.19	0.22	36.97	58.34	-21.16	---	NEUTRAL	QP
10	0.38	21.87	0.22	21.65	48.34	-26.47	---	NEUTRAL	AVERAGE
11	0.63	15.99	0.27	15.72	46.00	-30.01	---	NEUTRAL	AVERAGE
12	0.63	31.36	0.27	31.09	56.00	-24.64	---	NEUTRAL	QP

Note:

1. Emission Level = reading value + correction factor.
2. Correction factor = cable loss + insertion loss of LISN.
3. Q.P. is abbreviation of quasi-peak.

Tx Fundamental, for reference only. Please refer to next page.

Test Mode : Continuous Transmitting, with dummy load
 Tester : CDC Frequency Range : 150kHz~30MHz
 Phase : Neutral

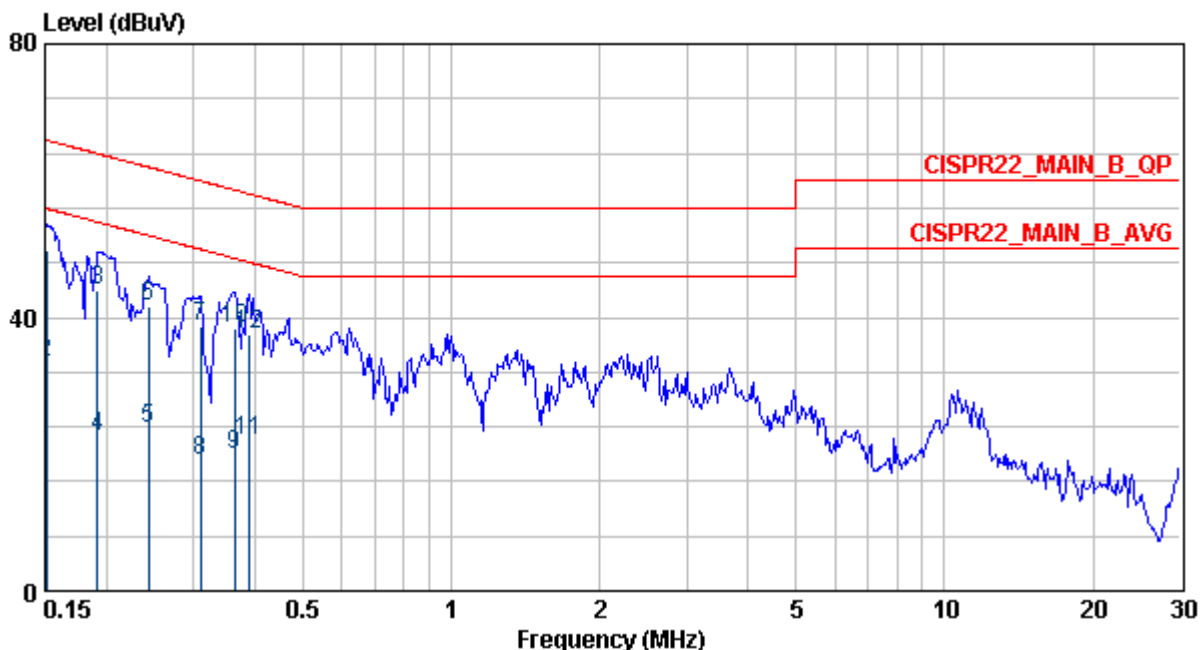

	Freq	Level	Factor	Read Level	Limit Line	Over Limit	Ant Pos	Pol/Phase	Remark
	MHz	dBuV	dB	dBuV	dBuV	dB	cm		
1	0.15	49.95	0.19	49.76	65.96	-16.00	---	NEUTRAL	QP
2	0.15	33.40	0.19	33.21	55.96	-22.56	---	NEUTRAL	AVERAGE
3	0.19	43.90	0.20	43.70	63.98	-20.07	---	NEUTRAL	QP
4	0.19	22.53	0.20	22.33	53.98	-31.45	---	NEUTRAL	AVERAGE
5	0.24	23.67	0.21	23.46	52.00	-28.33	---	NEUTRAL	AVERAGE
6	0.24	41.64	0.21	41.44	62.00	-20.35	---	NEUTRAL	QP
7	0.31	38.55	0.21	38.34	59.97	-21.42	---	NEUTRAL	QP
8	0.31	19.03	0.21	18.82	49.97	-30.94	---	NEUTRAL	AVERAGE
9	0.36	19.82	0.22	19.61	48.65	-28.83	---	NEUTRAL	AVERAGE
10	0.36	38.43	0.22	38.22	58.65	-20.22	---	NEUTRAL	QP
11	0.39	22.11	0.22	21.89	48.08	-25.96	---	NEUTRAL	AVERAGE
12	0.39	37.64	0.22	37.42	58.08	-20.44	---	NEUTRAL	QP

Note:

1. Emission Level = reading value + correction factor.
2. Correction factor = cable loss + insertion loss of LISN.
3. Q.P. is abbreviation of quasi-peak.