



# Part 15C

# TEST REPORT

Product Name	Embedded WiFi module
Model	HF-A11x
FCC ID	AZYHF-A11X
Client	Hi-flying Electronics Technology Co.,Ltd.

**TA Technology (Shanghai) Co., Ltd.**

**TA Technology (Shanghai) Co., Ltd.**  
**Test Report**

Report No.: RZA1202-0233RF01R2

Page 2 of 109

**GENERAL SUMMARY**

<b>Product Name</b>	Embedded WiFi module	<b>Model</b>	HF-A11x
<b>FCC ID</b>	AZYHF-A11X	<b>Report No.</b>	RZA1202-0233RF01R2
<b>Client</b>	Hi-flying Electronics Technology Co.,Ltd.		
<b>Manufacturer</b>	Hi-flying Electronics Technology Co.,Ltd.		
<b>Reference Standard(s)</b>	<p><b>FCC CFR47 Part 15C (2010-12)</b> Radio Frequency Devices</p> <p><b>15.205</b> Restricted bands of operation;</p> <p><b>15.207</b> Conducted limits;</p> <p><b>15.209</b> Radiated emission limits; general requirements;</p> <p><b>15.247</b> Operation within the bands 902-928 MHz,2400-2483.5 MHz, and 5725-5850MHz.</p> <p><b>ANSI C63.4</b> Methods of Measurement of Radio-Noise Emission from Low-Voltage Electrical and Electronic Equipment in the Range of 9 KHz to 40GHz. (2009)</p> <p><b>KDB 558074</b> Measurement of Digital Transmission Systems Operating under Section 15.247 (2005)</p>		
<b>Conclusion</b>	<p>This portable wireless equipment has been measured in all cases requested by the relevant standards. Test results in Chapter 2 of this test report are below limits specified in the relevant standards.</p> <p>General Judgment: <b>Pass</b></p> <div style="text-align: right;">  <p>(Stamp) Date of issue: March 21<sup>st</sup>, 2012</p> </div>		
<b>Comment</b>	The test result only responds to the measured sample.		

Approved by 杨伟中  
Director

Revised by 徐凯  
RF Manager

Performed by 王  
RF Engineer

## TABLE OF CONTENT

1. General Information .....	4
1.1. Notes of the test report .....	4
1.2. Testing laboratory .....	4
1.3. Applicant Information .....	5
1.4. Manufacturer Information .....	5
1.5. Information of EUT .....	6
1.6. Test Date .....	6
2. Test Information .....	7
2.1. Summary of test results .....	7
2.2. Peak Power Output –Conducted.....	8
2.3. Occupied Bandwidth (6dB) .....	10
2.4. Band Edge Compliance .....	18
2.5. Spurious Radiated Emissions in the restricted band.....	23
2.6. Power Spectral Density.....	33
2.7. Spurious RF Conducted Emissions .....	41
2.8. Radiates Emission .....	55
2.9. Conducted Emissions .....	82
3. Main Test Instruments .....	107
ANNEX A: EUT Appearance and Test Setup.....	108
A.1 EUT Appearance .....	108
A.2 Test Setup .....	109

# TA Technology (Shanghai) Co., Ltd.

## Test Report

Report No.: RZA1202-0233RF01R2

Page 4 of 109

---

## 1. General Information

### 1.1. Notes of the test report

**TA Technology (Shanghai) Co., Ltd.** guarantees the reliability of the data presented in this test report, which is the results of measurements and tests performed for the items under test on the date and under the conditions stated in this test report and is based on the knowledge and technical facilities available at TA Technology (Shanghai) Co., Ltd. at the time of execution of the test.

**TA Technology (Shanghai) Co., Ltd.** is liable to the client for the maintenance by its personnel of the confidentiality of all information related to the items under test and the results of the test. This report only refers to the item that has undergone the test.

This report standalone dose not constitute or imply by its own an approval of the product by the certification Bodies or competent Authorities. This report cannot be used partially or in full for publicity and/or promotional purposes without previous written approval of **TA Technology (Shanghai) Co., Ltd.** and the Accreditation Bodies, if it applies.

If the electrical report is inconsistent with the printed one, it should be subject to the latter.

### 1.2. Testing laboratory

Company: TA Technology (Shanghai) Co., Ltd.  
Address: No.145, Jintang Rd, Tangzhen Industry Park, Pudong  
City: Shanghai  
Post code: 201201  
Country: P. R. China  
Contact: Yang Weizhong  
Telephone: +86-021-50791141/2/3  
Fax: +86-021-50791141/2/3-8000  
Website: <http://www.ta-shanghai.com>  
E-mail: [yangweizhong@ta-shanghai.com](mailto:yangweizhong@ta-shanghai.com)

# TA Technology (Shanghai) Co., Ltd.

## Test Report

Report No.: RZA1202-0233RF01R2

Page 5 of 109

---

### 1.3. Applicant Information

Company: Hi-flying Electronics Technology Co.,Ltd.  
Address: Room B101,456 Bibo Road Pudong,SHANGHAI  
City: SHANGHAI  
Postal Code: /  
Country: CHINA  
Contact: SEN XIE  
Telephone: 021-33908861-8017  
Fax: 021-33908861-8004

### 1.4. Manufacturer Information

Company: Hi-flying Electronics Technology Co.,Ltd.  
Address: Room B101,456 Bibo Road Pudong,SHANGHAI  
City: SHANGHAI  
Postal Code: /  
Country: CHINA  
Telephone: 021-33908861-8017  
Fax: 021-33908861-8004

# TA Technology (Shanghai) Co., Ltd.

## Test Report

Report No.: RZA1202-0233RF01R2

Page 6 of 109

### 1.5. Information of EUT

#### General information

Product Name:	Embedded WiFi module
IMEI:	/
Hardware Version:	V3.1
Software Version:	V3.1
Antenna Type:	Internal Antenna
Device Operating Configurations:	
Supporting Function:	802.11b, 802.11g, 802.11n HT20 , 802.11n HT40; (tested)
Power Supply:	DC Power
Max Conducted Power	17.38 dBm
Extreme Voltage:	Minimum: 3.135 V    Maximum: 3.465 V
Extreme Temperature:	Lowest:-10°C    Highest: +70°C
Operating Frequency Range(s)	2400 MHz ~ 2483.5 MHz

Equipment Under Test (EUT) is a Embedded WiFi module. The detail about these is in chapter 1.5 in this report. The EUT supports WiFi function.

The sample under test was selected by the Client.

Components list please refer to documents of the manufacturer.

### 1.6. Test Date

The test is performed from March 1, 2012 to March 20, 2012.

**TA Technology (Shanghai) Co., Ltd.**  
**Test Report**

Report No.: RZA1202-0233RF01R2

Page 7 of 109

## 2. Test Information

### 2.1. Summary of test results

Number	Summary of measurements of results	Clause in FCC rules	Verdict
1	Peak Power Output –Conducted	15.247(b)(3)	PASS
2	Minimum 6dB bandwidth	15.247(a)(2)	PASS
3	Band Edges compliance	15.247(d)	PASS
4	Spurious Radiated Emissions in the restricted band	15.247(d),15.205,15.209	PASS
5	Power spectral Density	15.247(e)	PASS
6	Conducted Spurious Emission	15.247	PASS
7	Radiates Emission	15.247(d),15.205,15.209	PASS
8	Conducted Emissions	15.207,15.107	PASS

# TA Technology (Shanghai) Co., Ltd.

## Test Report

### 2.2. Peak Power Output –Conducted

#### Ambient condition

Temperature	Relative humidity	Pressure
23°C ~ 25°C	45% ~ 50%	101.5kPa

#### Methods of Measurement

During the process of the testing, The EUT was connected to the peak power meter through an external attenuator and a known loss cable. The EUT is max power transmission with proper modulation. We use the Power Output Option 1 in KDB 558074 for this test.

#### Test Setup

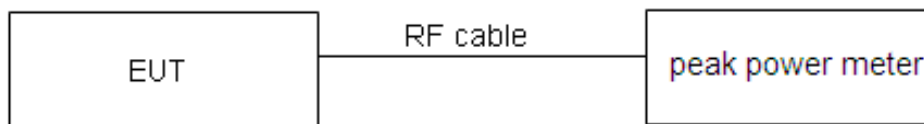

#### Limits

Rule Part 15.247 (b) (3) specifies that " For systems using digital modulation in the 902–928 MHz, 2400–2483.5 MHz, and 5725–5850 MHz bands: 1 Watt."

Peak Output Power	≤ 1W (30dBm)
-------------------	--------------

#### Measurement Uncertainty

The assessed measurement uncertainty to ensure 95% confidence level for the normal distribution is with the coverage factor  $k = 2$ ,  $U = 0.44$  dB.



# TA Technology (Shanghai) Co., Ltd.

## Test Report

**Test Results: Pass**

Network Standards	Data Rate	Peak Output Power (dBm)		
		CH 1	CH 6	CH 11
802.11b	1 Mbps	<b>17.25</b>	<b>17.38</b>	<b>16.68</b>
	2 Mbps	17.12	17.28	16.65
	5.5 Mbps	17.11	17.24	16.75
	11 Mbps	17.07	17.35	16.89
802.11g	6 Mbps	<b>14.24</b>	<b>14.64</b>	<b>14.25</b>
	9 Mbps	14.15	14.56	14.14
	12 Mbps	14.13	14.48	14.12
	18 Mbps	14.08	14.62	14.06
	24 Mbps	14.02	14.45	13.98
	36 Mbps	13.98	14.37	13.85
	48 Mbps	13.89	14.29	13.84
	54 Mbps	13.82	14.18	13.78
802.11n HT20	MCS0	<b>14.04</b>	<b>14.54</b>	<b>13.85</b>
	MCS1	14.02	14.45	13.82
	MCS2	13.98	14.38	13.77
	MCS3	13.89	14.29	13.75
	MCS4	13.78	14.24	13.68
	MCS5	13.74	14.18	13.62
	MCS6	13.68	14.15	13.64
	MCS7	13.65	14.06	13.57
Network Standards	Data Rate	Peak Output Power (dBm)		
		CH 3	CH 6	CH 9
802.11n HT40	MCS0	<b>14.23</b>	<b>14.92</b>	<b>14.95</b>
	MCS1	14.15	14.82	14.67
	MCS2	14.14	14.76	14.58
	MCS3	14.09	14.45	14.48
	MCS4	13.96	14.36	14.38
	MCS5	13.86	14.28	14.29
	MCS6	13.75	14.18	14.16
	MCS7	13.67	14.09	14.11

Note: 1. The following testing items should be tested at the data rate with the maximum output power.

2. The maximum output power values are marked in bold.

### 2.3. Occupied Bandwidth (6dB)

#### Ambient condition

Temperature	Relative humidity	Pressure
23°C ~25°C	45%~50%	101.5kPa

#### Method of Measurement

The EUT was connected to the spectrum analyzer through an external attenuator (20dB) and a known loss cable. RBW is set to 100 KHz and VBW is set to 300 KHz on spectrum analyzer.

#### Test Setup

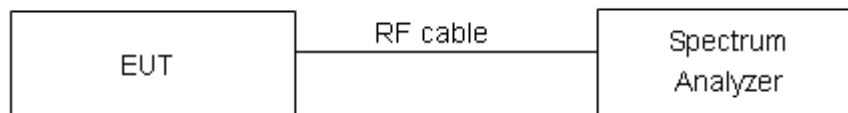

#### Limits

Rule Part 15.247 (a) (2) specifies that “Systems using digital modulation techniques may operate in the 902–928 MHz, 2400–2483.5 MHz, and 5725–5850 MHz bands. The minimum 6 dB bandwidth shall be at least 500 KHz.”

minimum 6 dB bandwidth	≥ 500 KHz
------------------------	-----------

#### Measurement Uncertainty

The assessed measurement uncertainty to ensure 95% confidence level for the normal distribution is with the coverage factor  $k = 2$ ,  $U = 936$  Hz.

# TA Technology (Shanghai) Co., Ltd. Test Report

Report No.: RZA1202-0233RF01R2

Page 11 of 109

**Test Results:**

Network Standards	Carrier frequency (MHz)	Minimum 6 dB bandwidth (MHz)	Conclusion
802.11b	2412	12.159	PASS
	2437	12.166	PASS
	2462	12.171	PASS
802.11g	2412	16.360	PASS
	2437	16.370	PASS
	2462	16.353	PASS
802.11n HT20	2412	17.084	PASS
	2437	17.080	PASS
	2462	16.994	PASS
802.11n HT40	2422	35.255	PASS
	2437	35.265	PASS
	2452	35.177	PASS

802.11b

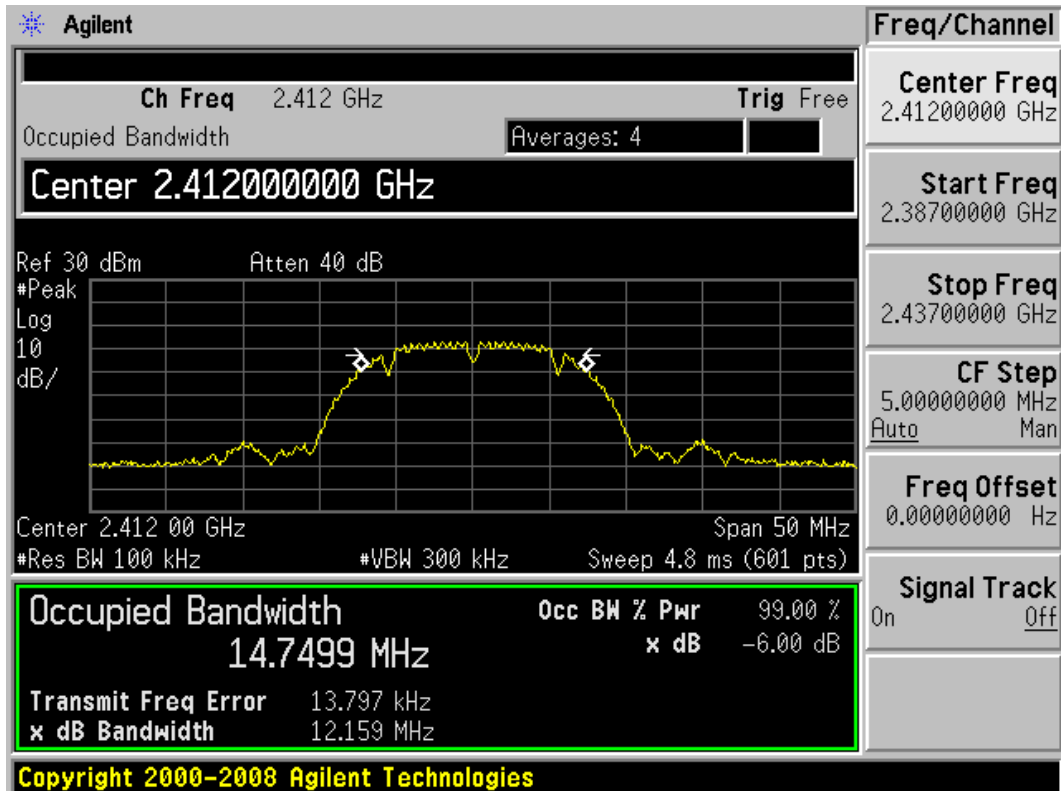

802.11b, Carrier frequency (MHz): 2412

# TA Technology (Shanghai) Co., Ltd. Test Report

Report No.: RZA1202-0233RF01R2

Page 12 of 109

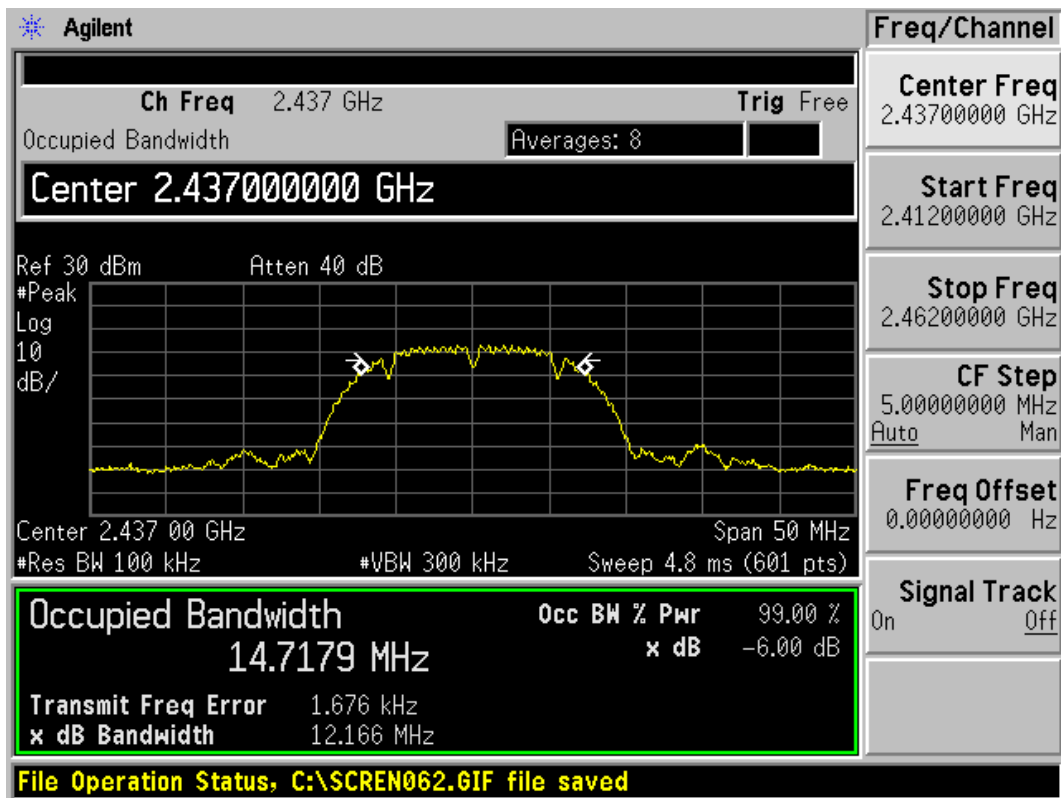

802.11b, Carrier frequency (MHz): 2437

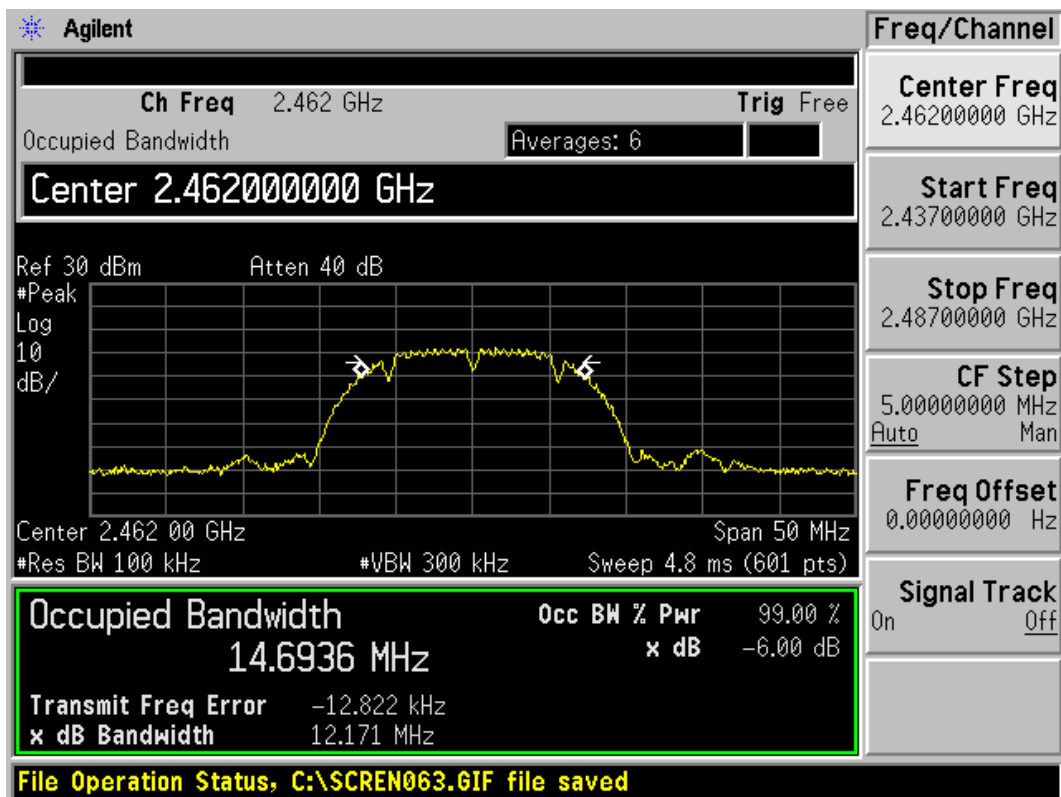

802.11b, Carrier frequency (MHz): 2462

# TA Technology (Shanghai) Co., Ltd. Test Report

Report No.: RZA1202-0233RF01R2

Page 13 of 109

802.11g

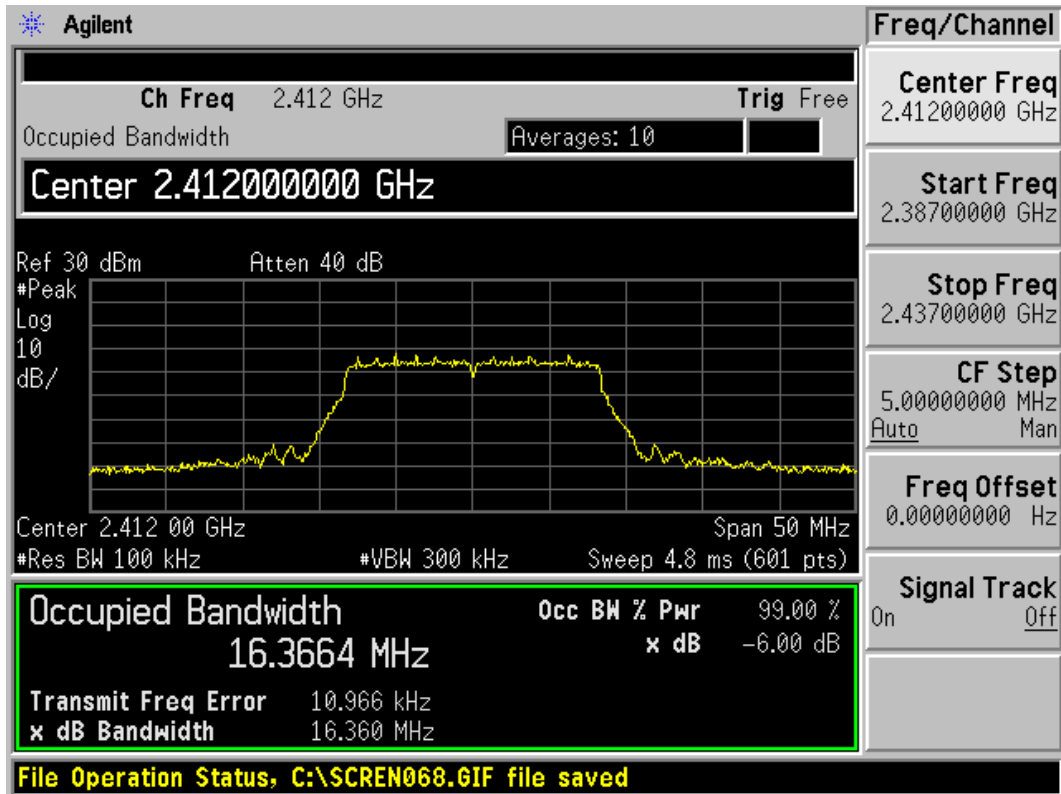

802.11g, Carrier frequency (MHz): 2412

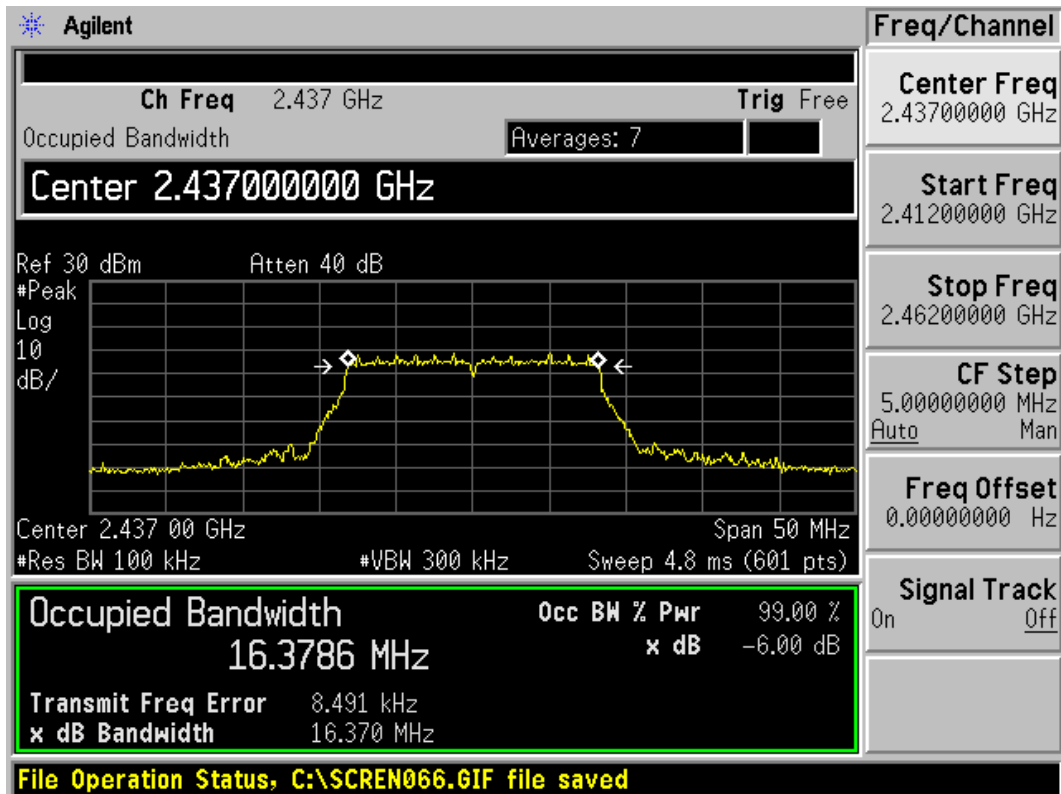

802.11g, Carrier frequency (MHz): 2437

# TA Technology (Shanghai) Co., Ltd. Test Report

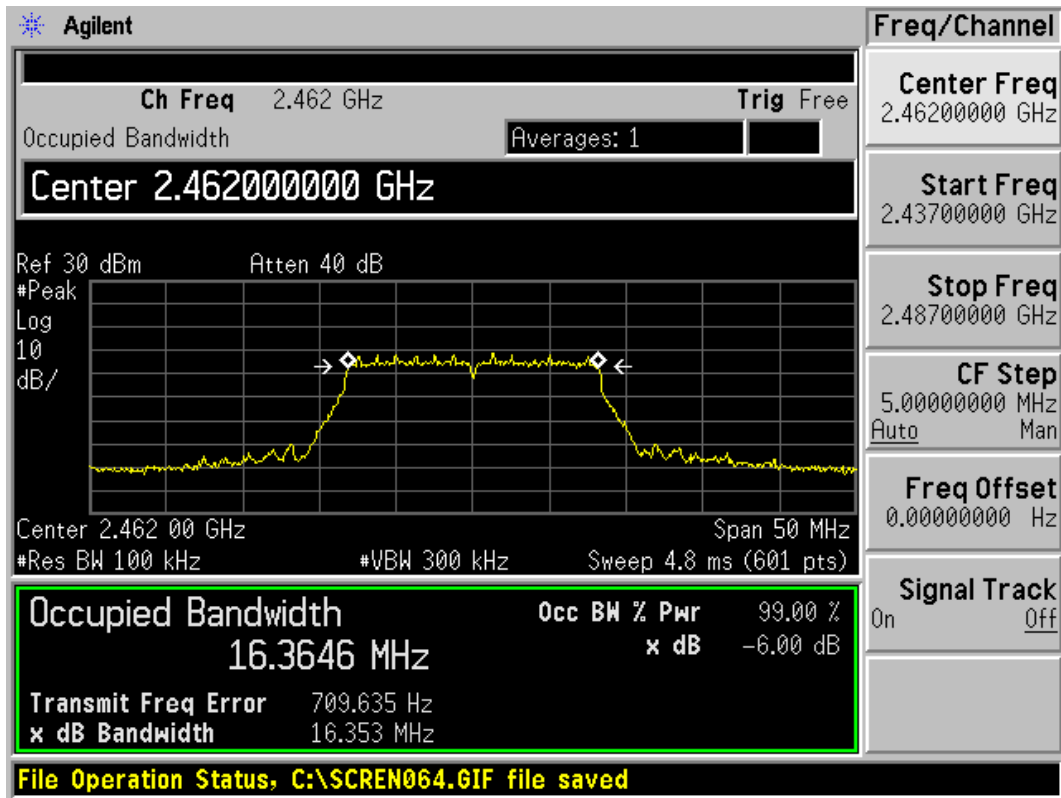

802.11g, Carrier frequency (MHz):2462

802.11n HT20

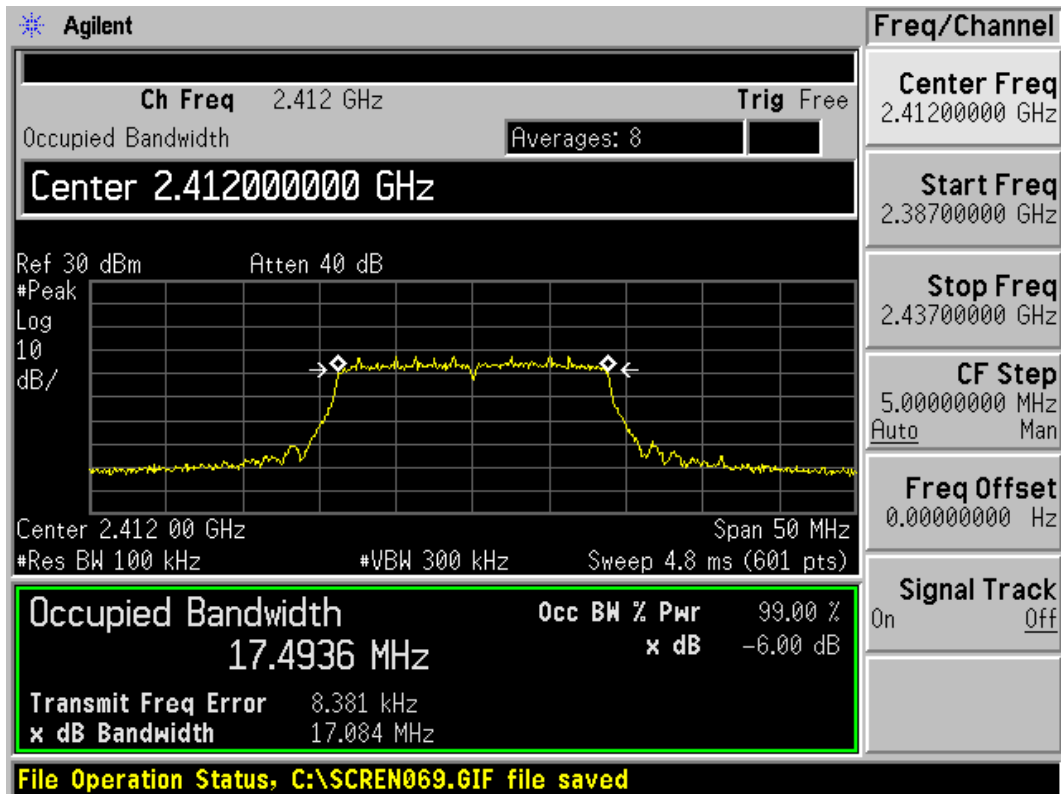

802.11n HT20, Carrier frequency (MHz): 2412

# TA Technology (Shanghai) Co., Ltd. Test Report

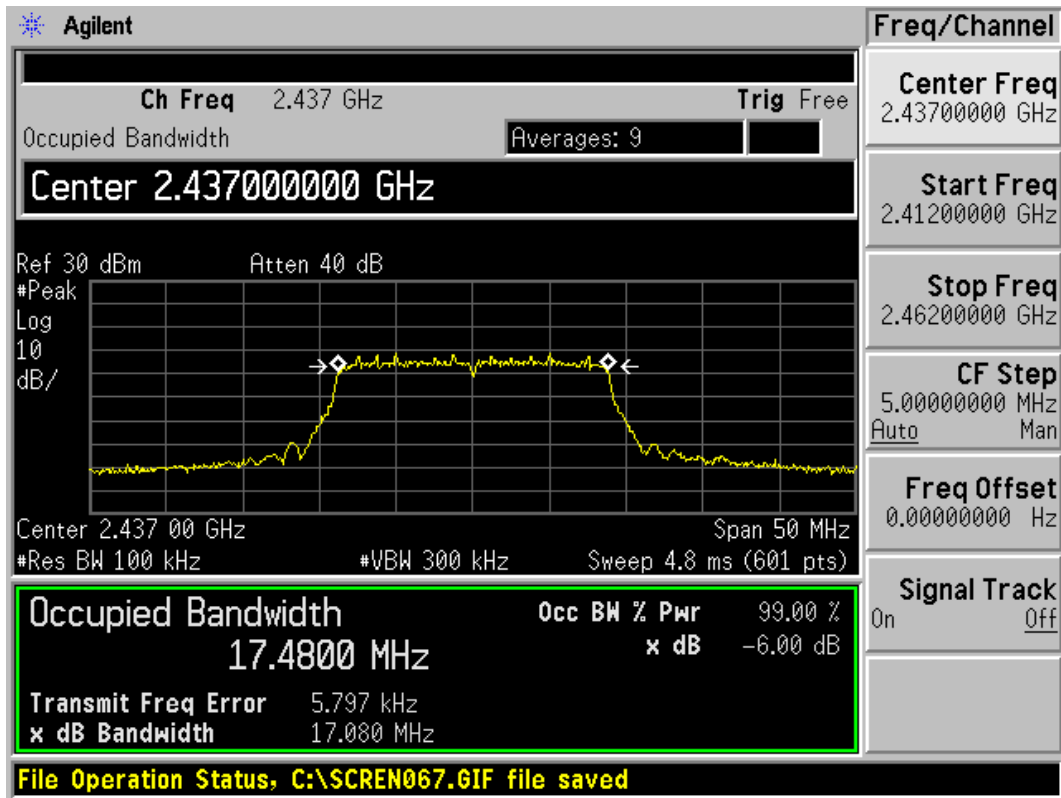

802.11n HT20, Carrier frequency (MHz): 2437

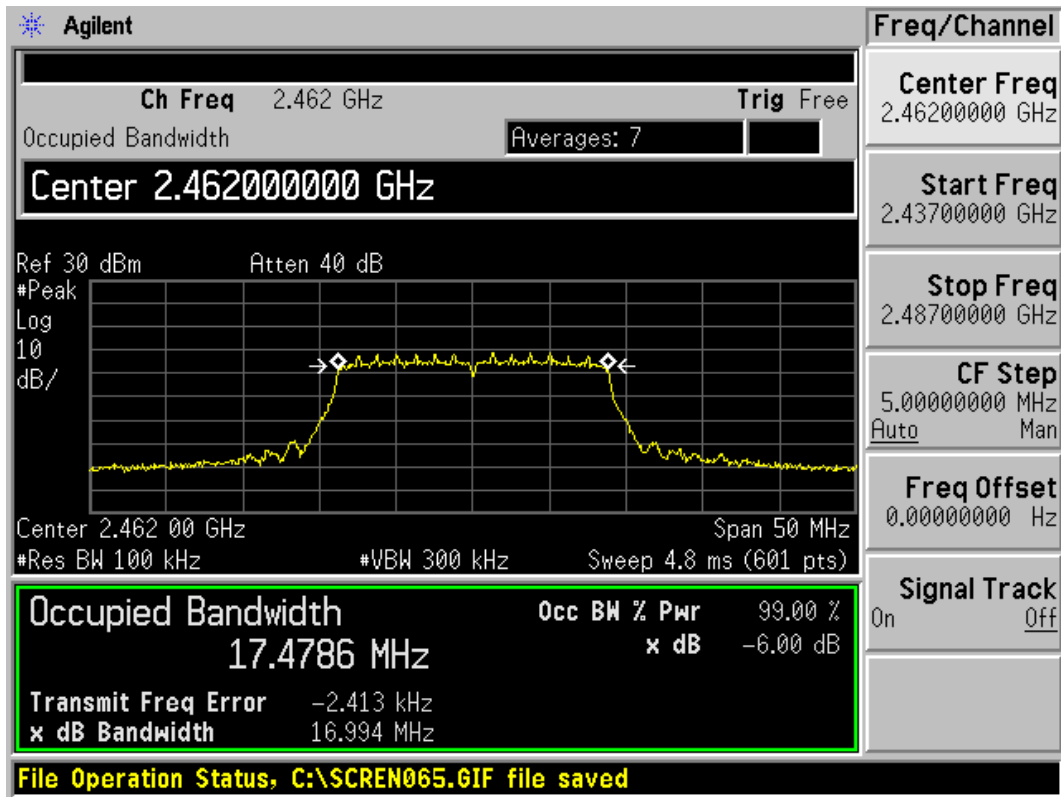

802.11n HT20, Carrier frequency (MHz):2462

# TA Technology (Shanghai) Co., Ltd. Test Report

Report No.: RZA1202-0233RF01R2

Page 16 of 109

802.11n HT40

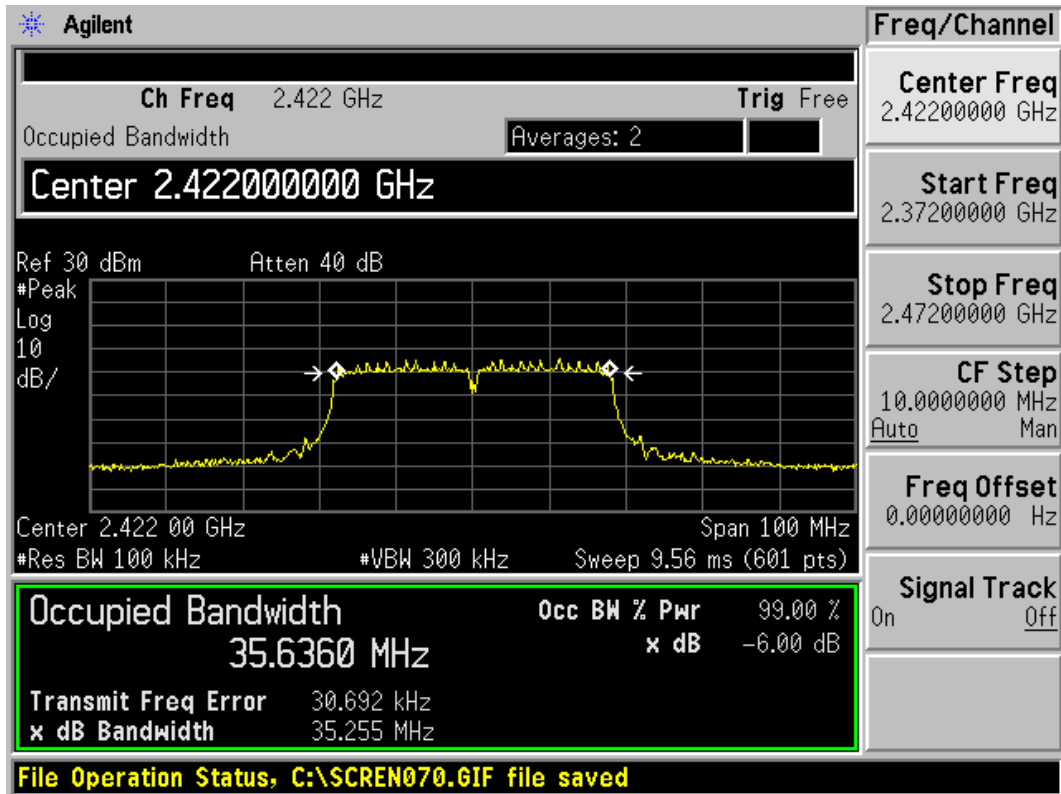

802.11n HT40, Carrier frequency (MHz): 2422

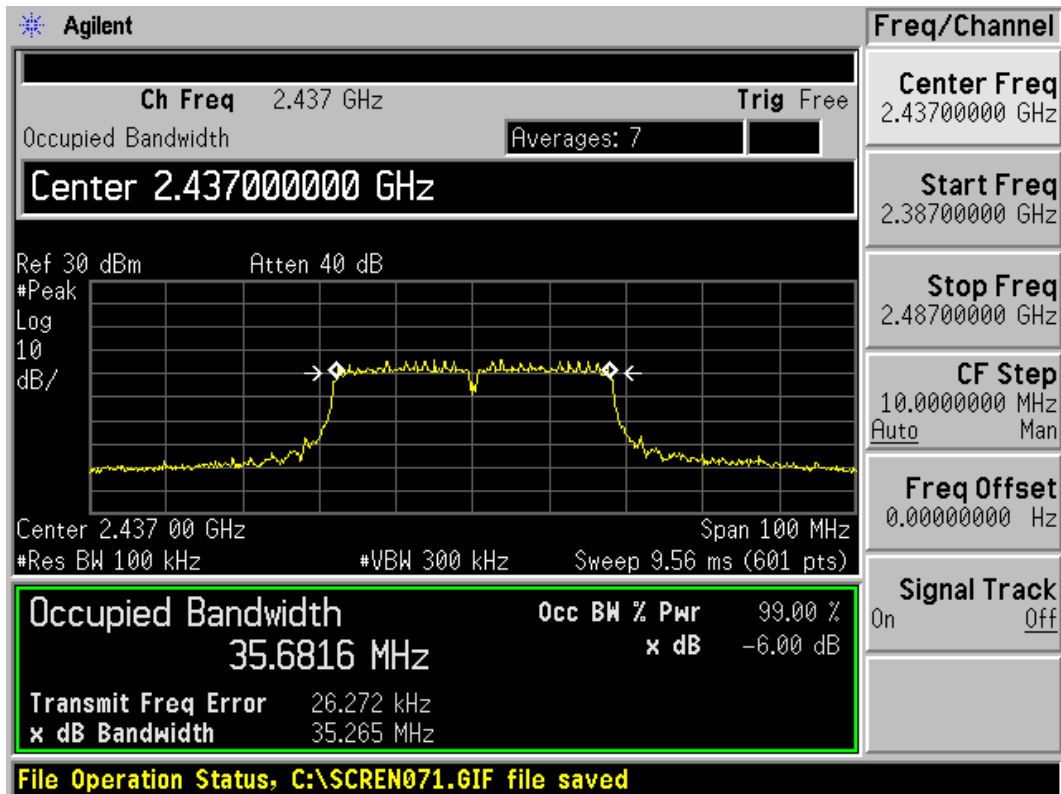

802.11n HT40, Carrier frequency (MHz): 2437



# TA Technology (Shanghai) Co., Ltd. Test Report

Report No.: RZA1202-0233RF01R2

Page 17 of 109

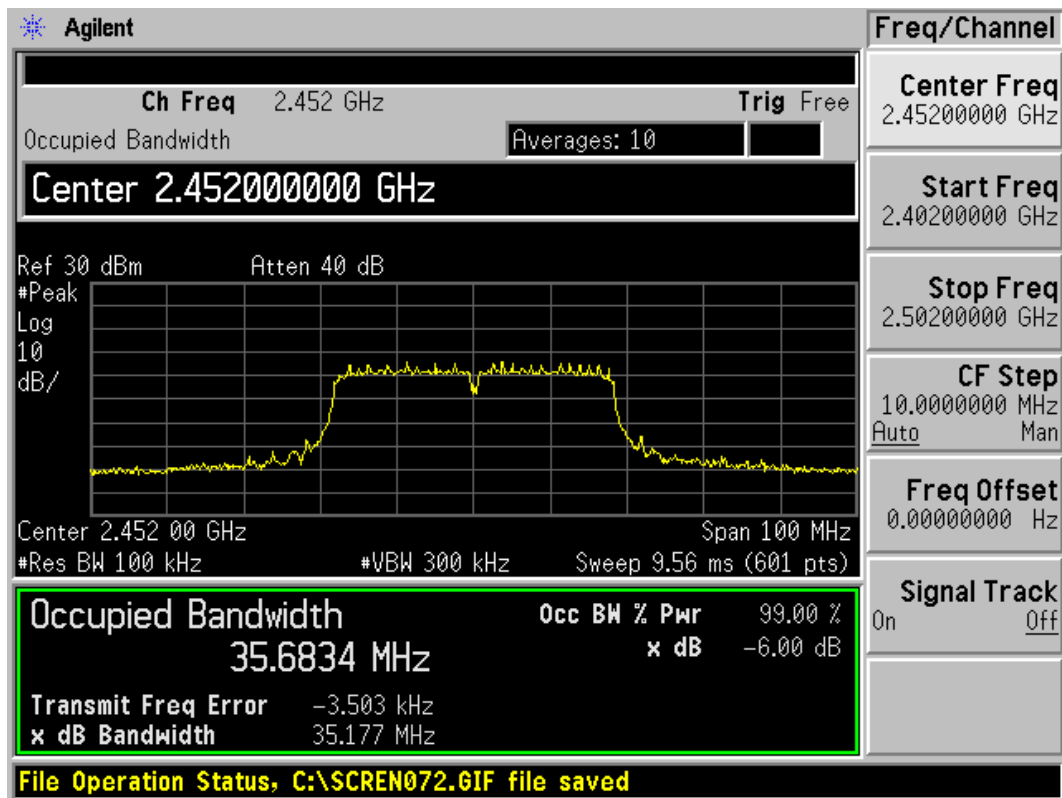

802.11n HT40, Carrier frequency (MHz):2452

# TA Technology (Shanghai) Co., Ltd.

## Test Report

Report No.: RZA1202-0233RF01R2

Page 18 of 109

### 2.4. Band Edge Compliance

#### Ambient condition

Temperature	Relative humidity	Pressure
23°C ~25°C	45%~50%	101.5kPa

#### Method of Measurement

The EUT was connected to the spectrum analyzer through an external attenuator (20dB) and a known loss cable the band edge of the lowest and highest channels were measured. The peak detector is used and RBW is set to 100kHz and VBW is set to 300kHz on spectrum analyzer. Spectrum analyzer plots are included on the following pages.

#### Test Setup

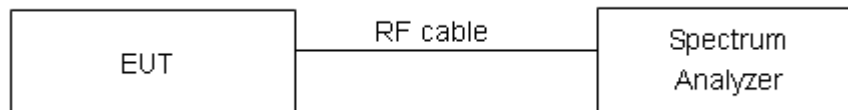

#### Limits

Rule Part 15.247(d) specifies that “In any 100 kHz bandwidth outside the frequency band in which the spread spectrum or digitally modulated intentional radiator is operating, the radio frequency power that is produced by the intentional radiator shall be at least 20 dB below that in the 100 kHz bandwidth within the band that contains the highest level of the desired power, based on either an RF conducted or a radiated measurement.”

Limit	$\geq 20$ dB
-------	--------------

#### Measurement Uncertainty

The assessed measurement uncertainty to ensure 95% confidence level for the normal distribution is with the coverage factor  $k = 1.96$ .

Frequency	Uncertainty
2GHz-3GHz	1.407 dB







# TA Technology (Shanghai) Co., Ltd. Test Report

802.11n HT40

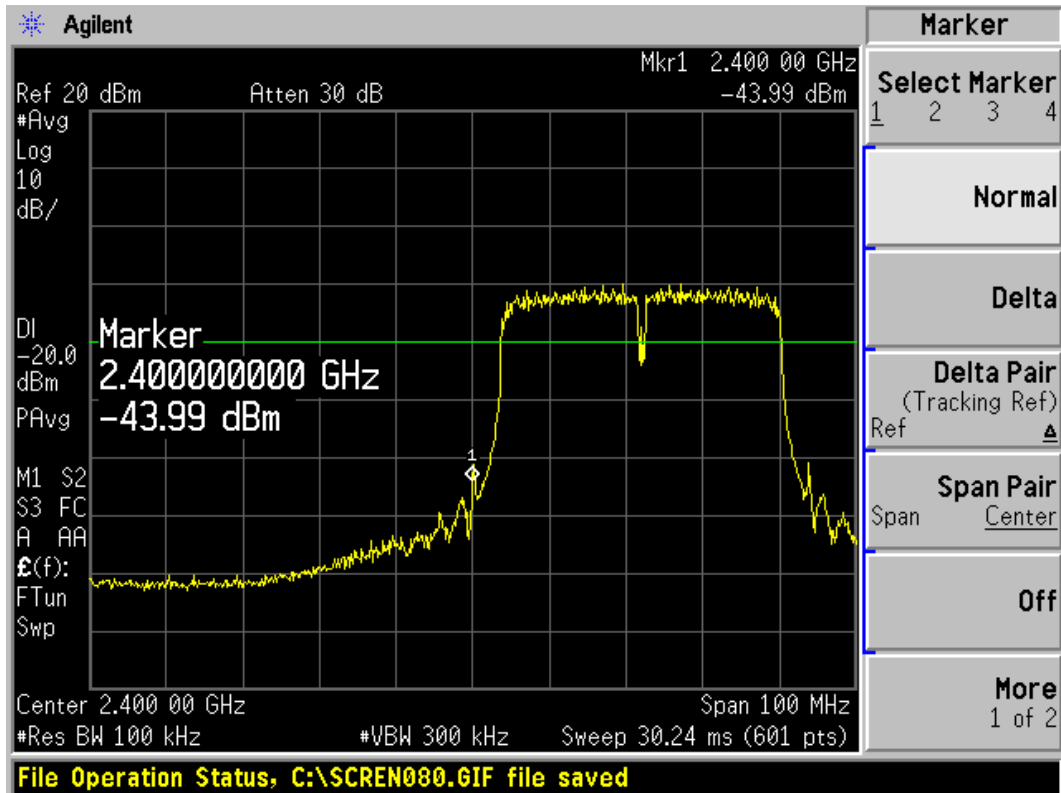

802.11n HT40, Channel No.: 3

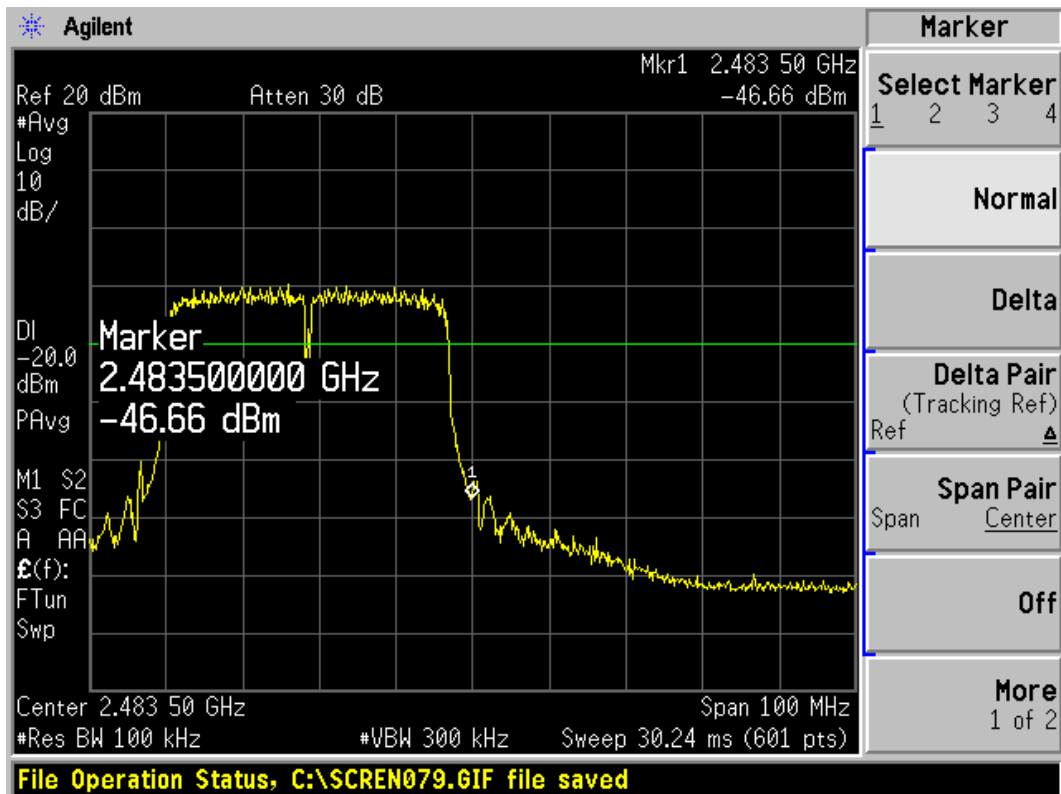

802.11n HT40, Channel No.: 9

## 2.5. Spurious Radiated Emissions in the restricted band

### Ambient condition

Temperature	Relative humidity	Pressure
23°C ~25°C	45%~50%	101.5kPa

The Equipment Under Test (EUT) was set up on a non-conductive table in the semi-anechoic chamber. The test was performed at the distance of 3 m between the EUT and the receiving antenna. The turntable shall be rotated from 0 to 360 degrees for detecting the maximum of radiated spurious signal level. The measurements shall be repeated with orthogonal polarization of the test antenna. RBW is set to 100 KHz. The data of cable loss and antenna factor has been calibrated in full testing frequency range before the testing.

Set the spectrum analyzer in the following:

- (a) PEAK: RBW=VBW=1MHz / Sweep=AUTO
- (b) AVERAGE: RBW=1MHz / VBW=10Hz / Sweep=AUTO

This setting method can refer to **KDB 558074**.

EUT in X-axis orientation is the worst case, the test is only for this case.  
The test is in transmitting mode.

### Test setup

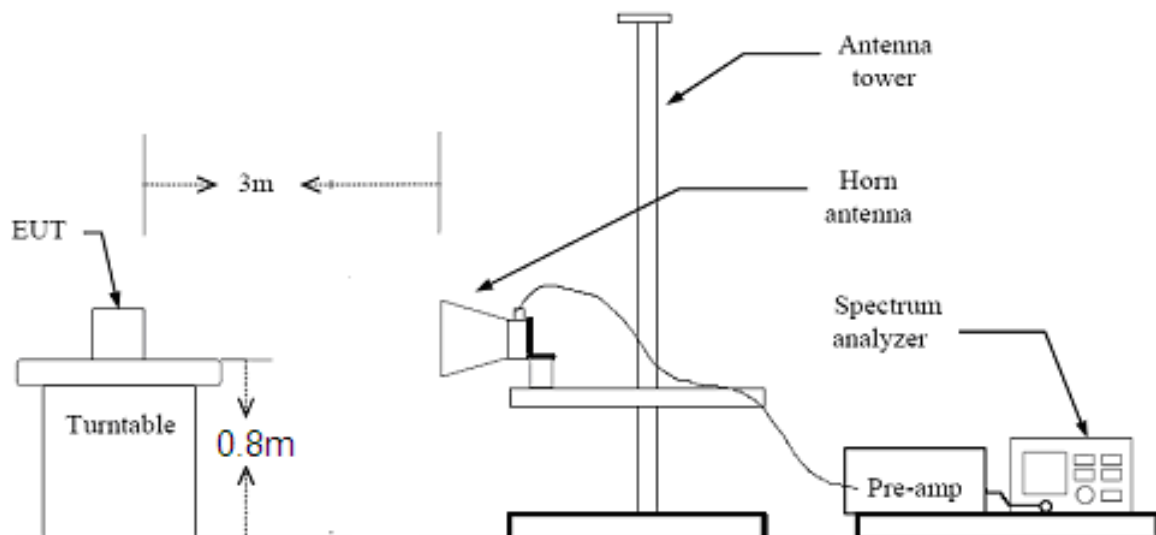

# TA Technology (Shanghai) Co., Ltd. Test Report

### Limits

Spurious Radiated Emissions are permitted in any of the frequency bands listed below:

MHz	MHz	MHz	GHz
0.090 - 0.110	16.42 - 16.423	399.9 - 410	4.5 - 5.15
<sup>1</sup> 0.495 - 0.505	16.69475 - 16.69525	608 - 614	5.35 - 5.46
2.1735 - 2.1905	16.80425 - 16.80475	960 - 1240	7.25 - 7.75
4.125 - 4.128	25.5 - 25.67	1300 - 1427	8.025 - 8.5
4.17725 - 4.17775	37.5 - 38.25	1435 - 1626.5	9.0 - 9.2
4.20725 - 4.20775	73 - 74.6	1645.5 - 1646.5	9.3 - 9.5
6.215 - 6.218	74.8 - 75.2	1660 - 1710	10.6 - 12.7
6.26775 - 6.26825	108 - 121.94	1718.8 - 1722.2	13.25 - 13.4
6.31175 - 6.31225	123 - 138	2200 - 2300	14.47 - 14.5
8.291 - 8.294	149.9 - 150.05	2310 - 2390	15.35 - 16.2
8.362 - 8.366	156.52475 - 156.52525	2483.5 - 2500	17.7 - 21.4
8.37625 - 8.38675	156.7 - 156.9	2690 - 2900	22.01 - 23.12
8.41425 - 8.41475	162.0125 - 167.17	3260 - 3267	23.6 - 24.0
12.29 - 12.293	167.72 - 173.2	3332 - 3339	31.2 - 31.8
12.51975 - 12.52025	240 - 285	3345.8 - 3358	36.43 - 36.5
12.57675 - 12.57725	322 - 335.4	3600 - 4400	( <sup>2</sup> )
13.36 - 13.41			

Limit in restricted band

Frequency of emission (MHz)	Field strength(uV/m)	Field strength(dBuV/m)
30-88	100	40
88-216	150	43.5
216-960	200	46
Above960	500	54

### §15.35(b)

There is also a limit on the radio frequency emissions, as measured using instrumentation with a peak detector function, corresponding to 20 dB above the maximum permitted average limit.

Peak Limit=74 dBuV/m

Average Limit=54 dBuV/m

### Measurement Uncertainty

The assessed measurement uncertainty to ensure 95% confidence level for the normal distribution is with the coverage factor  $k = 1.96$ ,  $U = 3.55$  dB.



Test Results: PASS

802.11b-Channel 1:

Peak

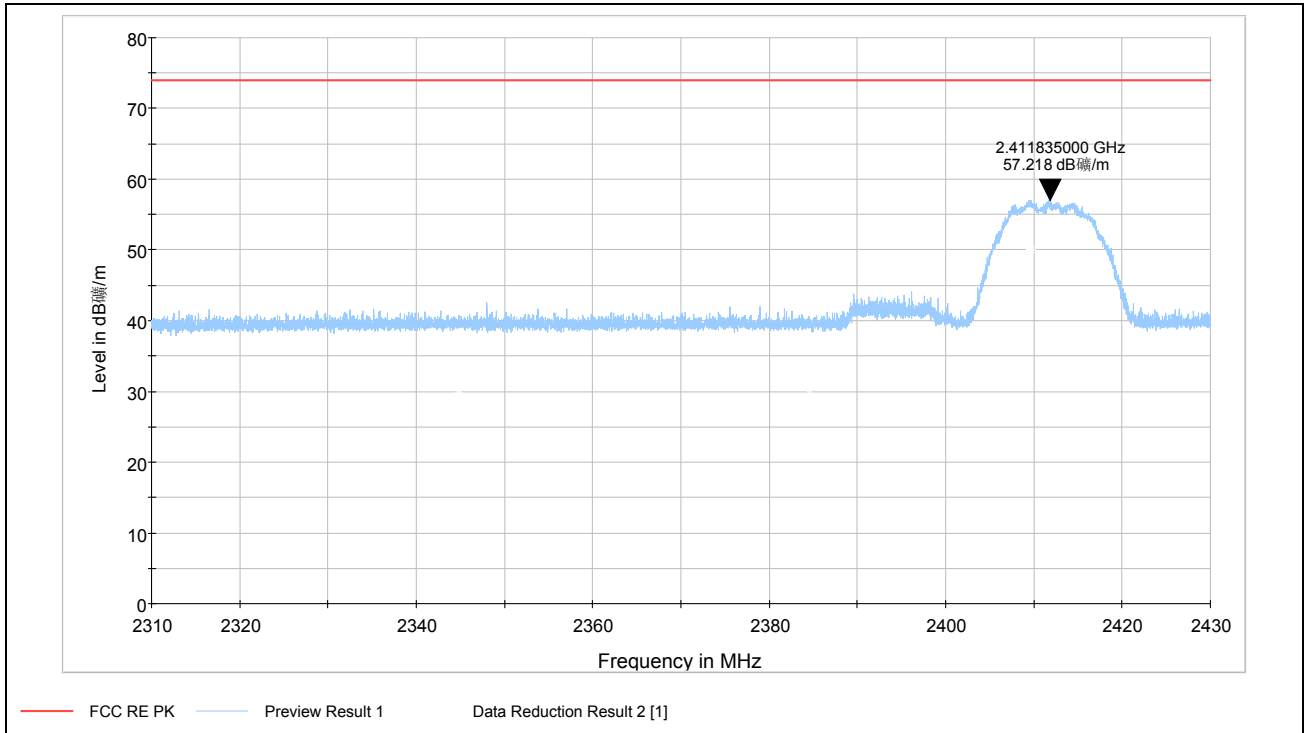

Note: The signal beyond the limit is carrier  
Channel 1

Average

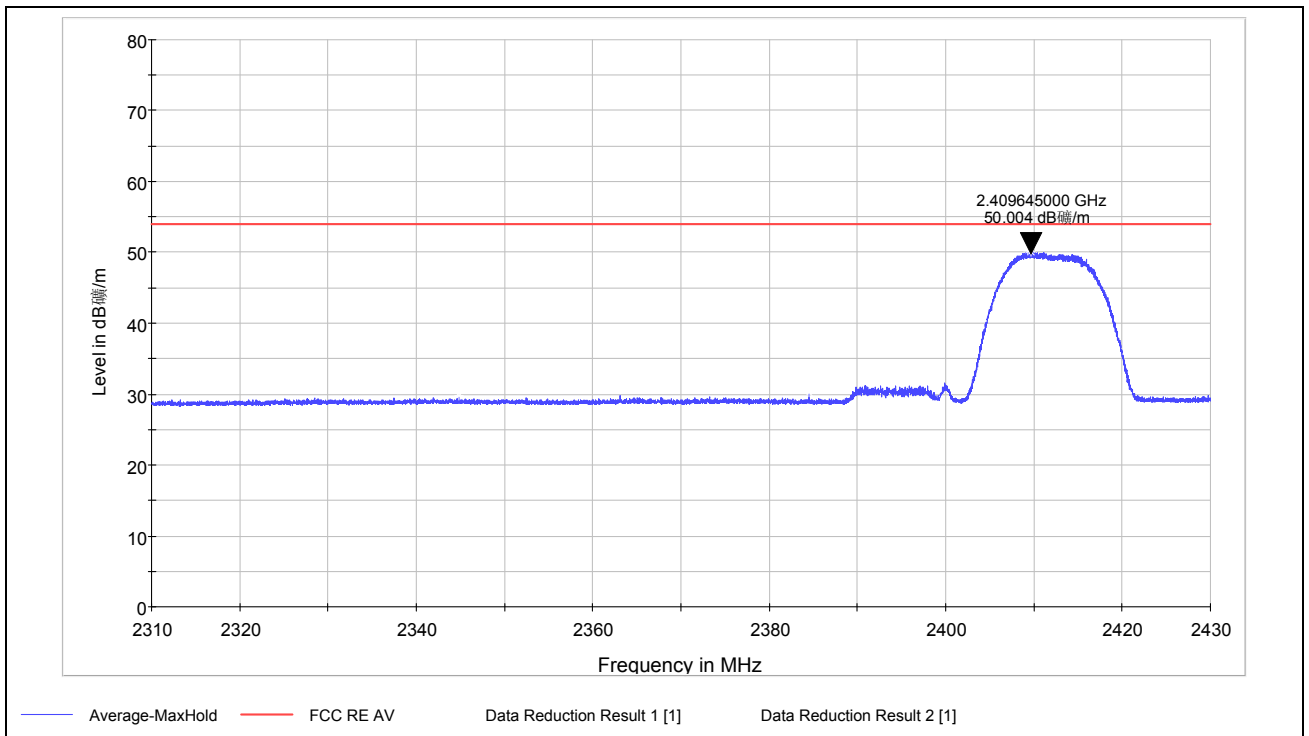

Note: The signal beyond the limit is carrier  
Channel 1

802.11b-Channel 11:

Peak

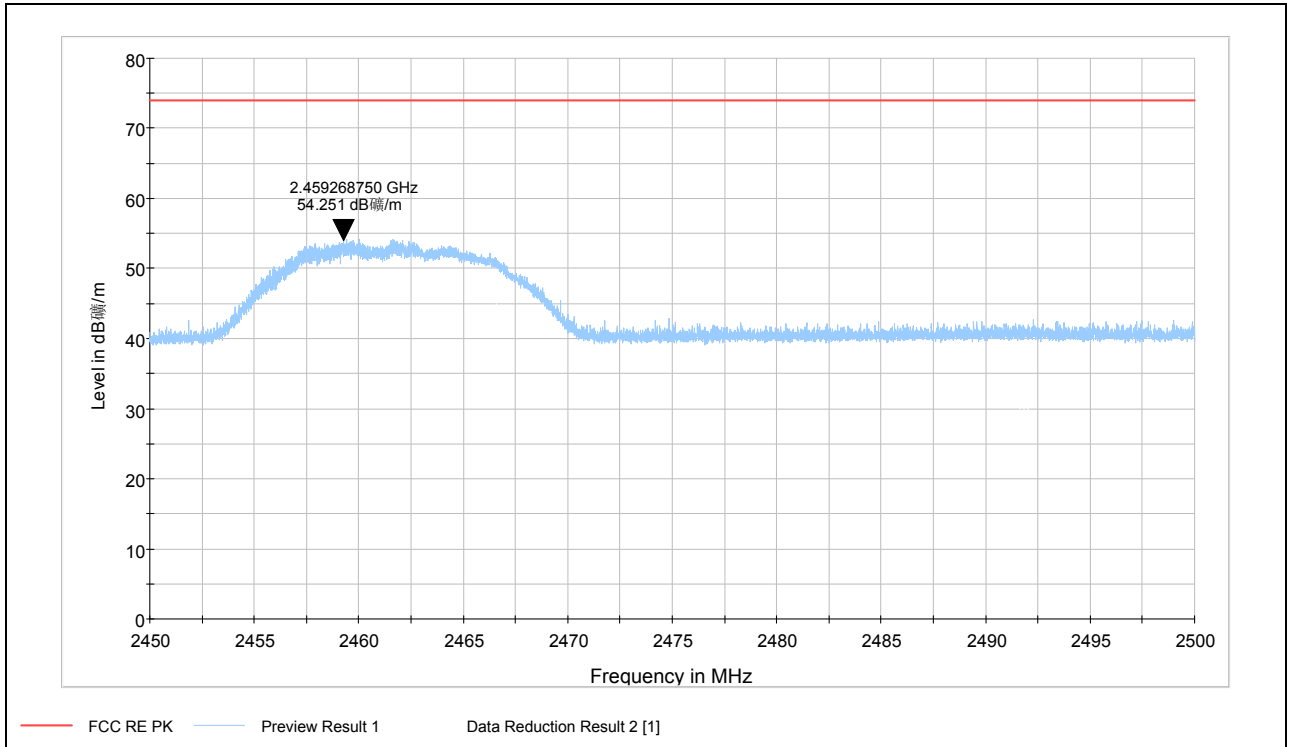

Note: The signal beyond the limit is carrier  
Channel 11

Average

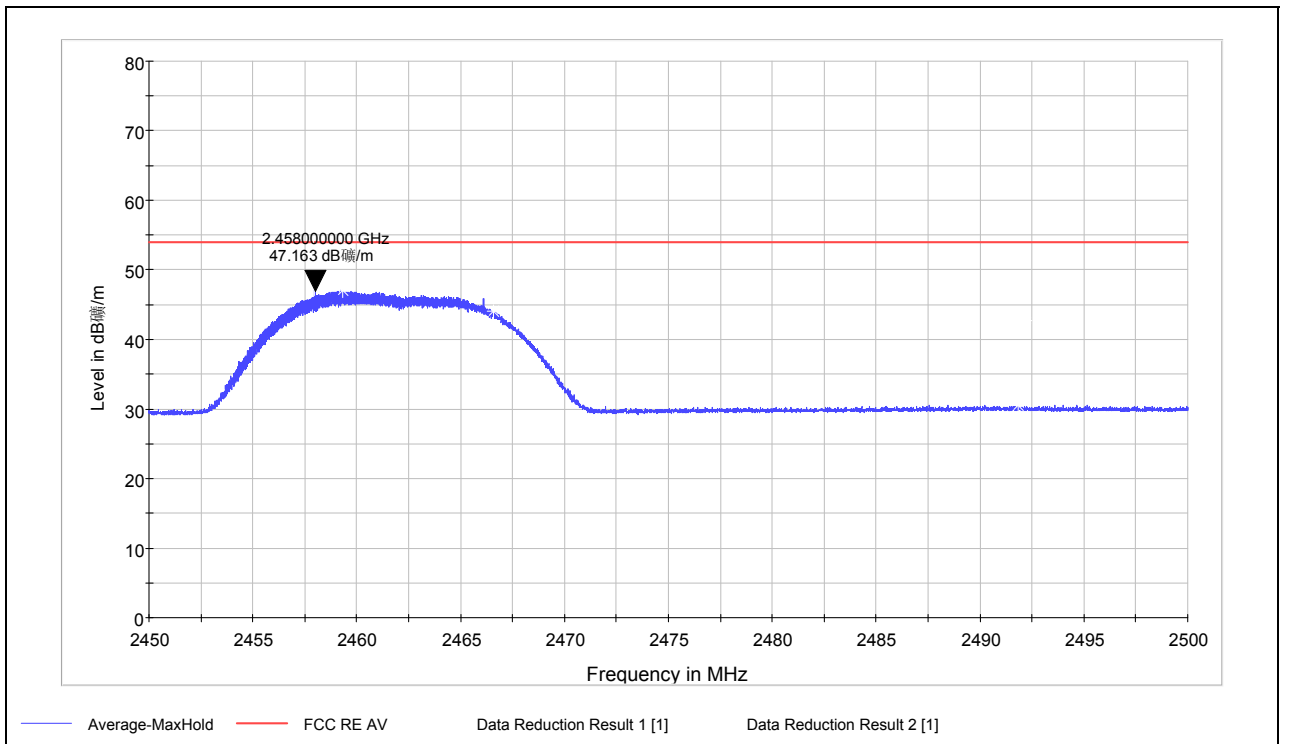

Note: The signal beyond the limit is carrier  
Channel 11

802.11g-Channel 1:

Peak

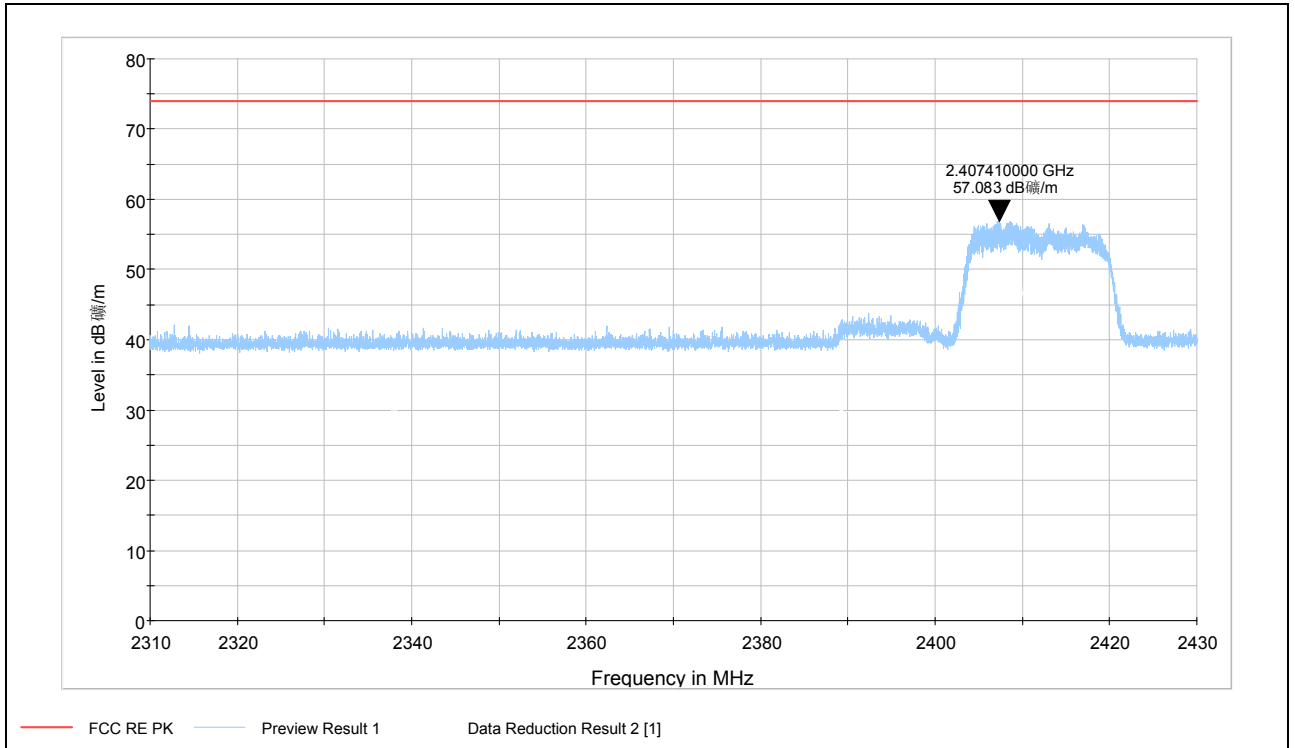

Note: The signal beyond the limit is carrier  
Channel 1

Average

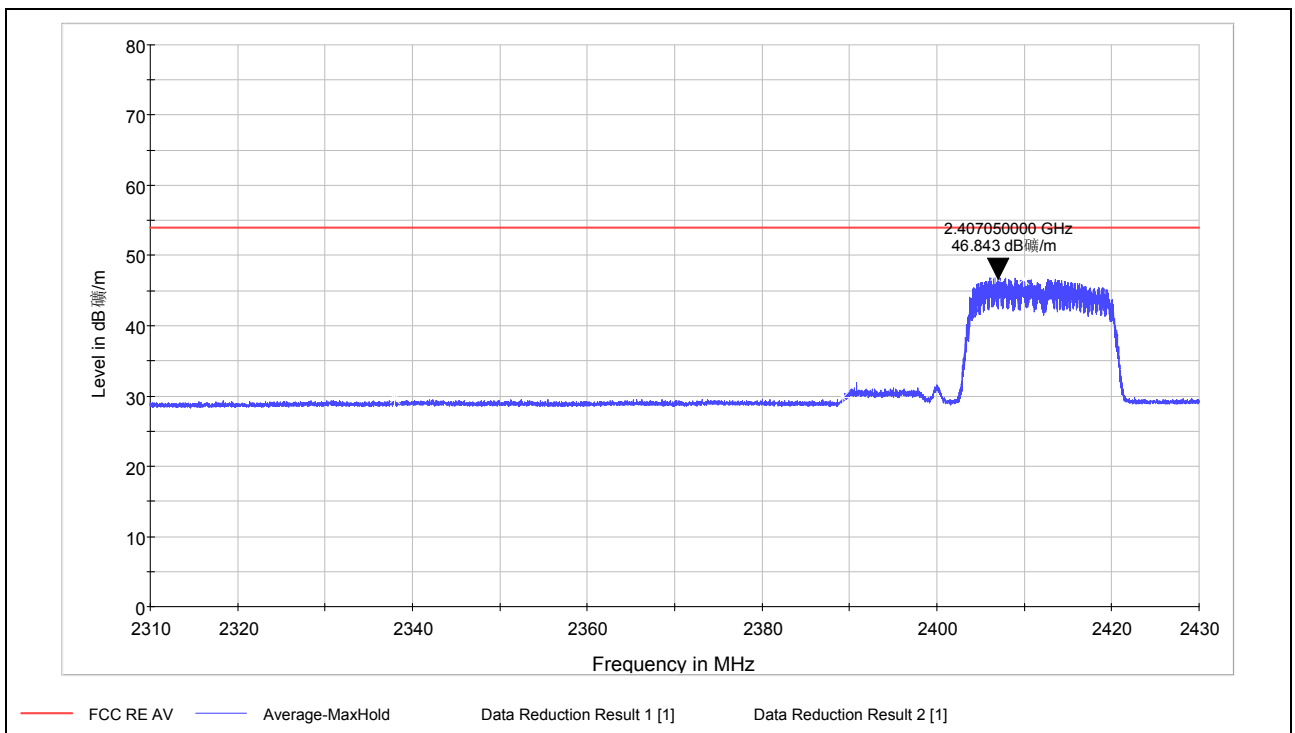

Note: The signal beyond the limit is carrier  
Channel 1

802.11g-Channel 11:

Peak

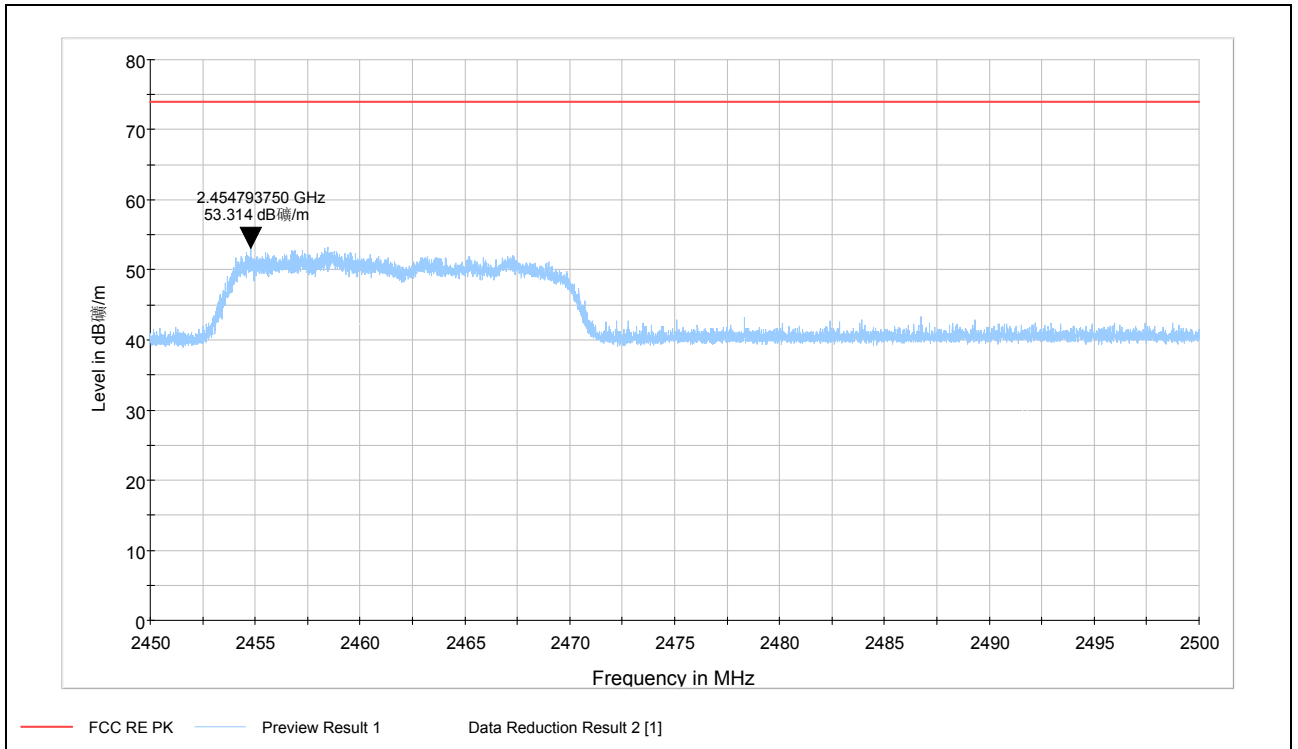

Note: The signal beyond the limit is carrier  
Channel 11

Average

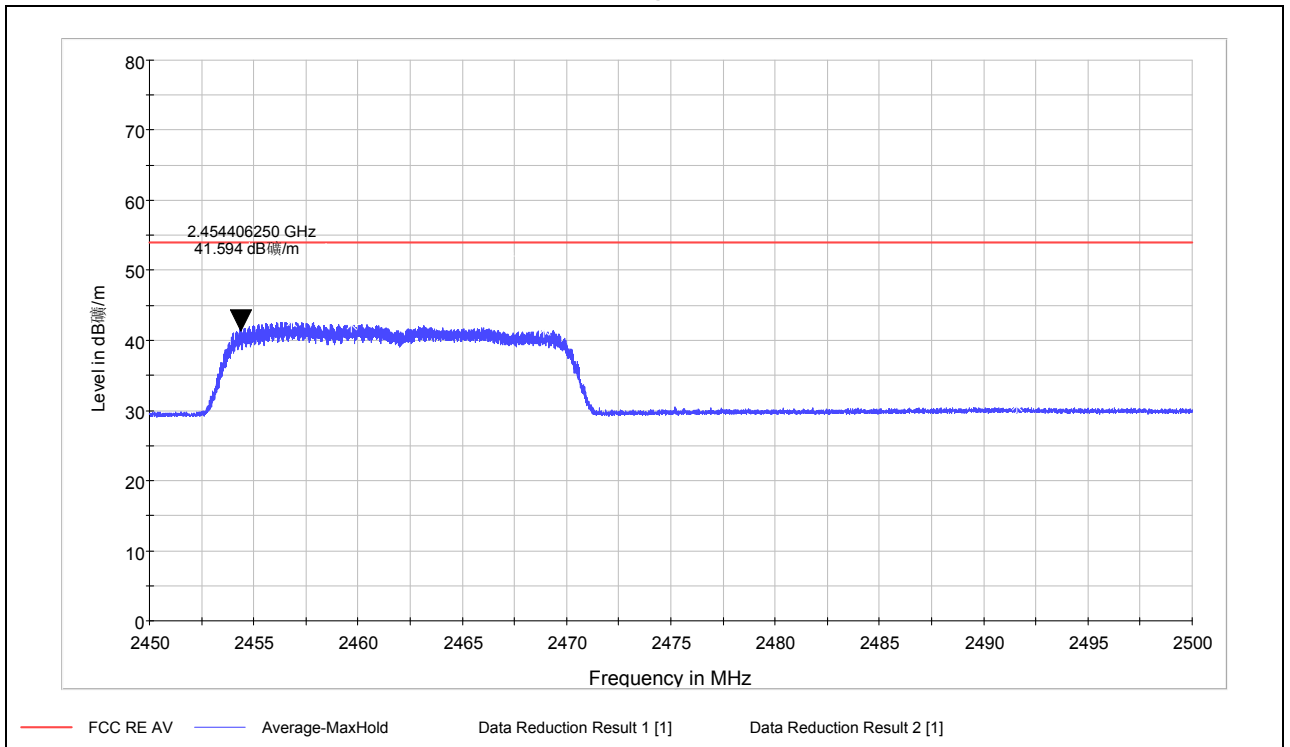

Note: The signal beyond the limit is carrier  
Channel 11

802.11n HT20-Channel 1:

Peak

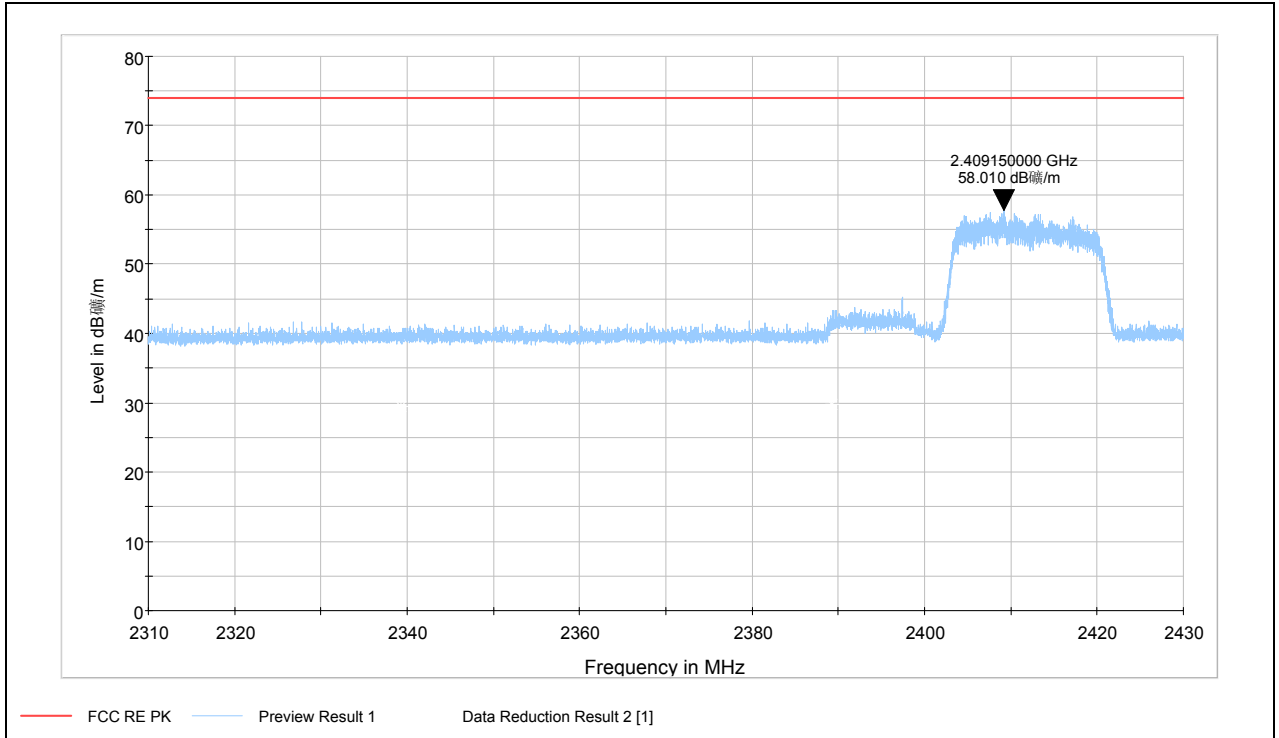

Note: The signal beyond the limit is carrier  
Channel 1

Average

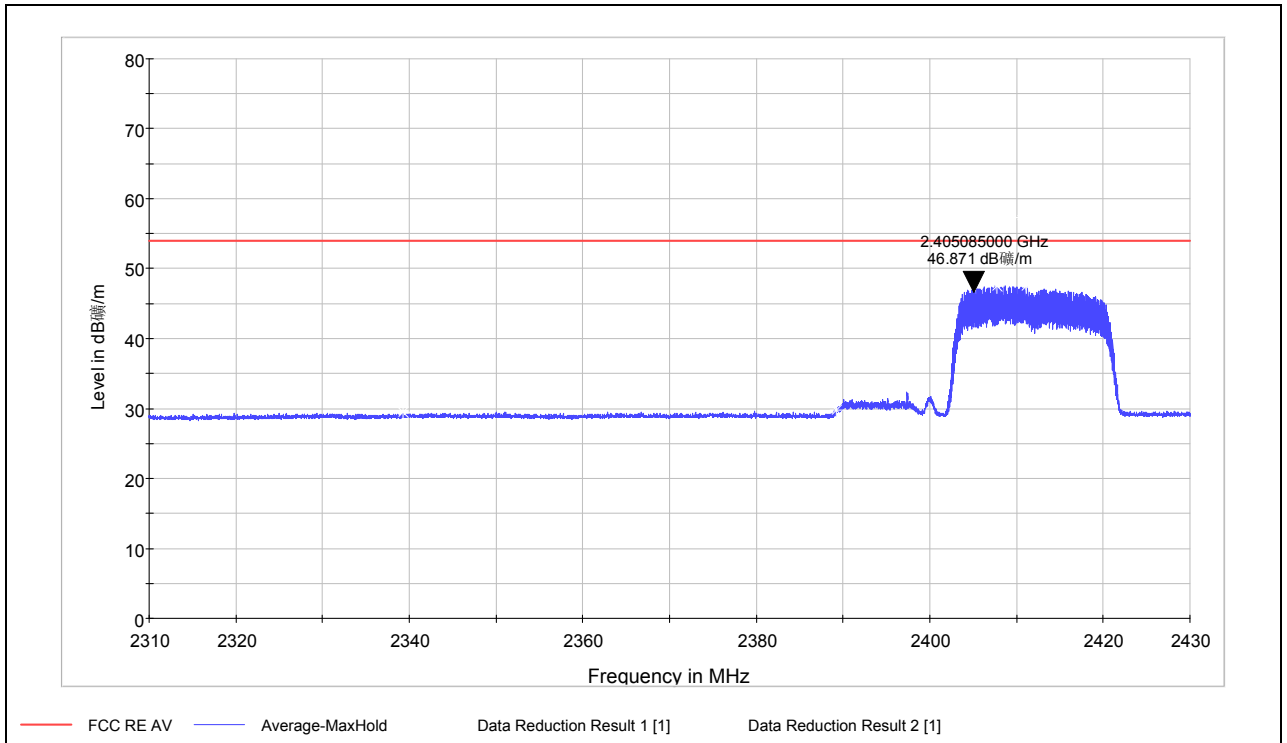

Note: The signal beyond the limit is carrier  
Channel 1

802.11n HT20-Channel 11:

Peak

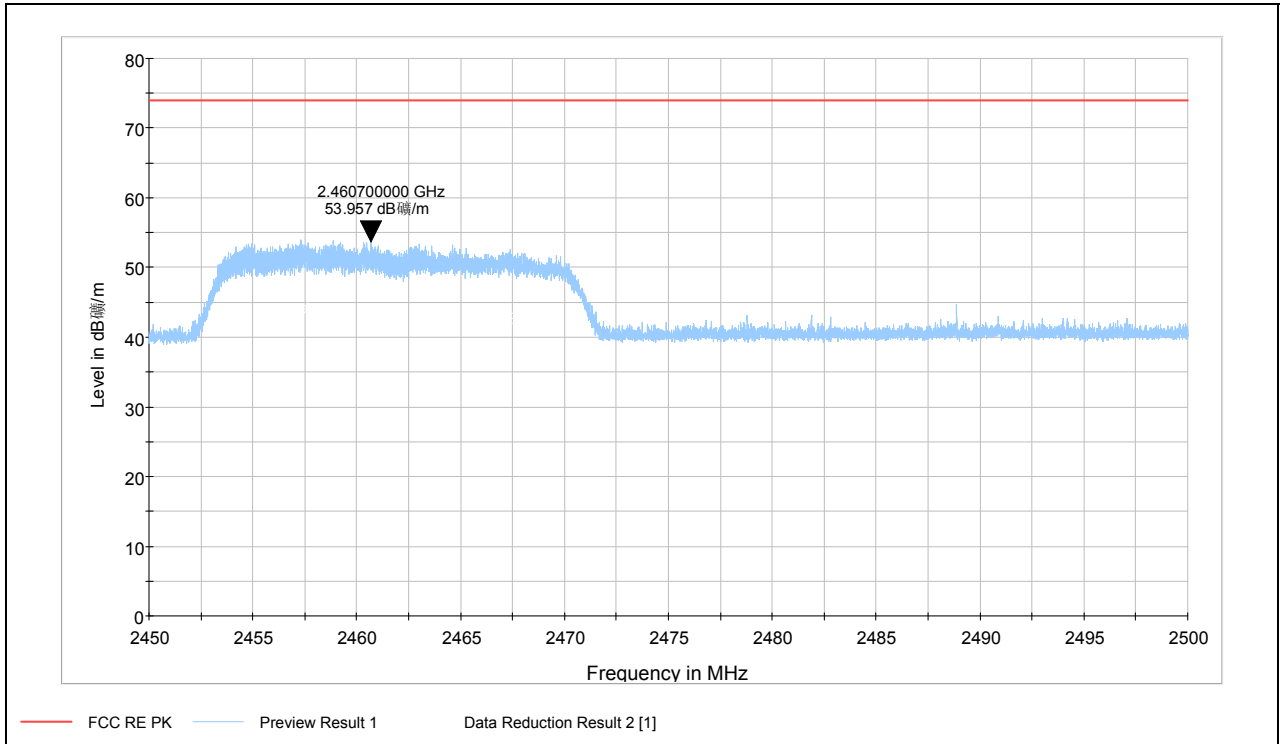

Note: The signal beyond the limit is carrier  
Channel 11

Average

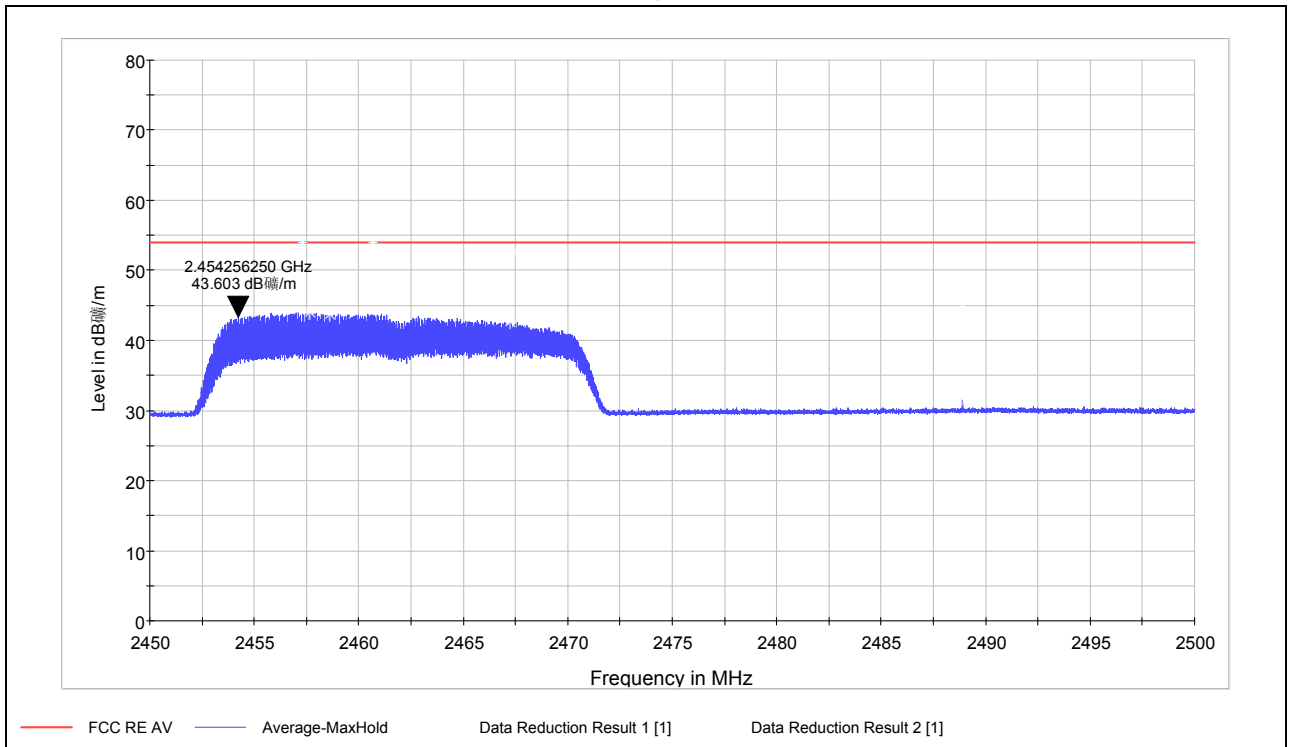

Note: The signal beyond the limit is carrier  
Channel 11

802.11n HT40-Channel 3:

Peak

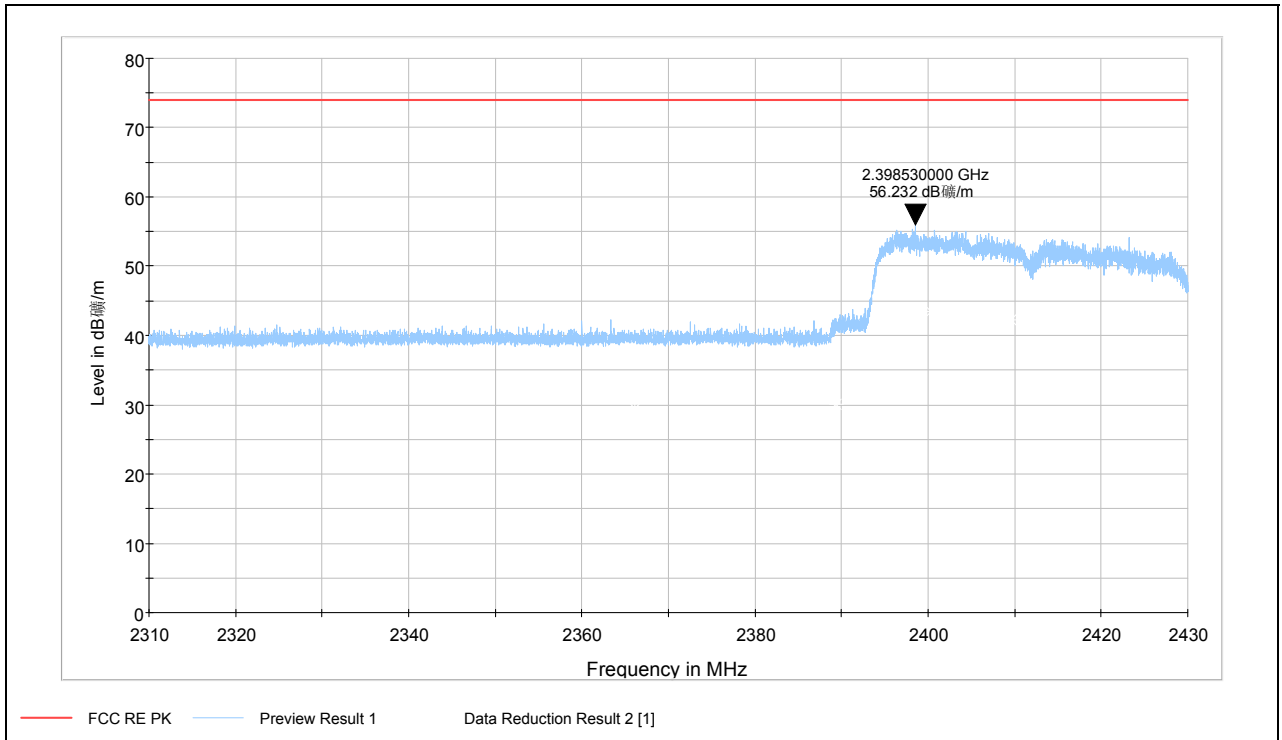

Note: The signal beyond the limit is carrier  
Channel 3

Average

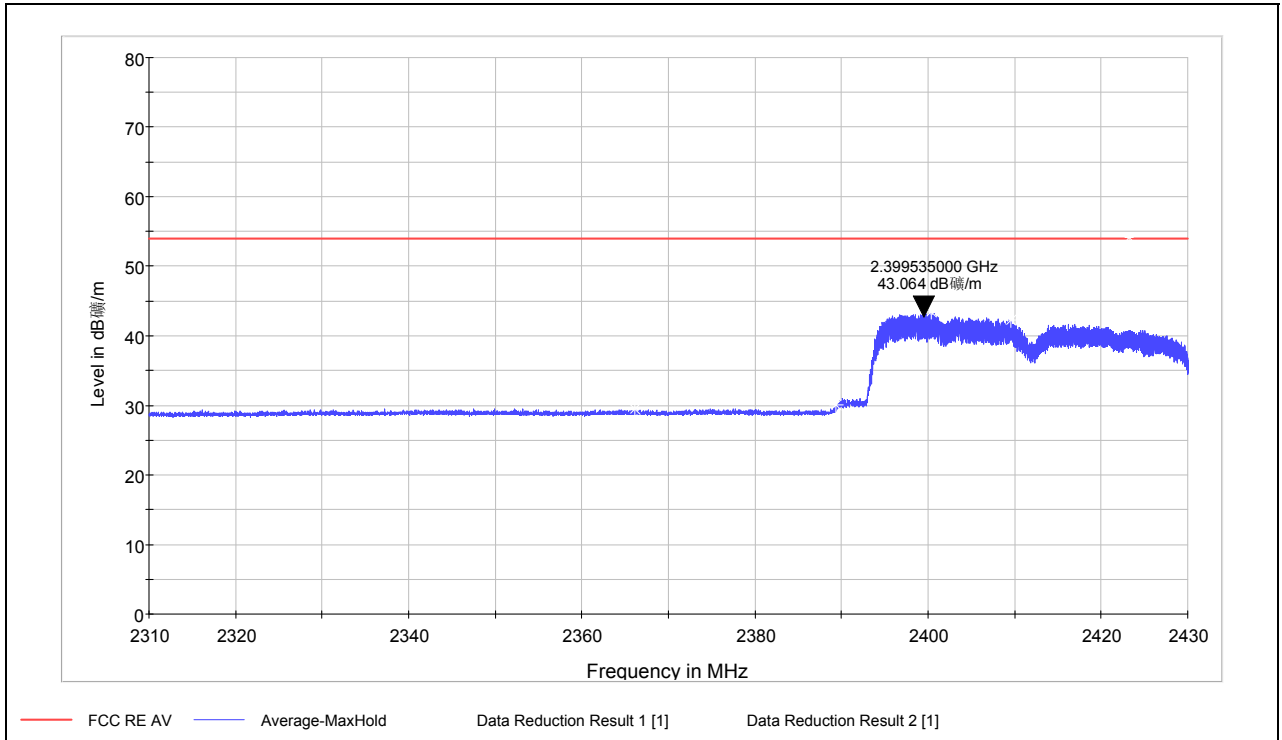

Note: The signal beyond the limit is carrier  
Channel 3

802.11n HT40-Channel 9:

Peak

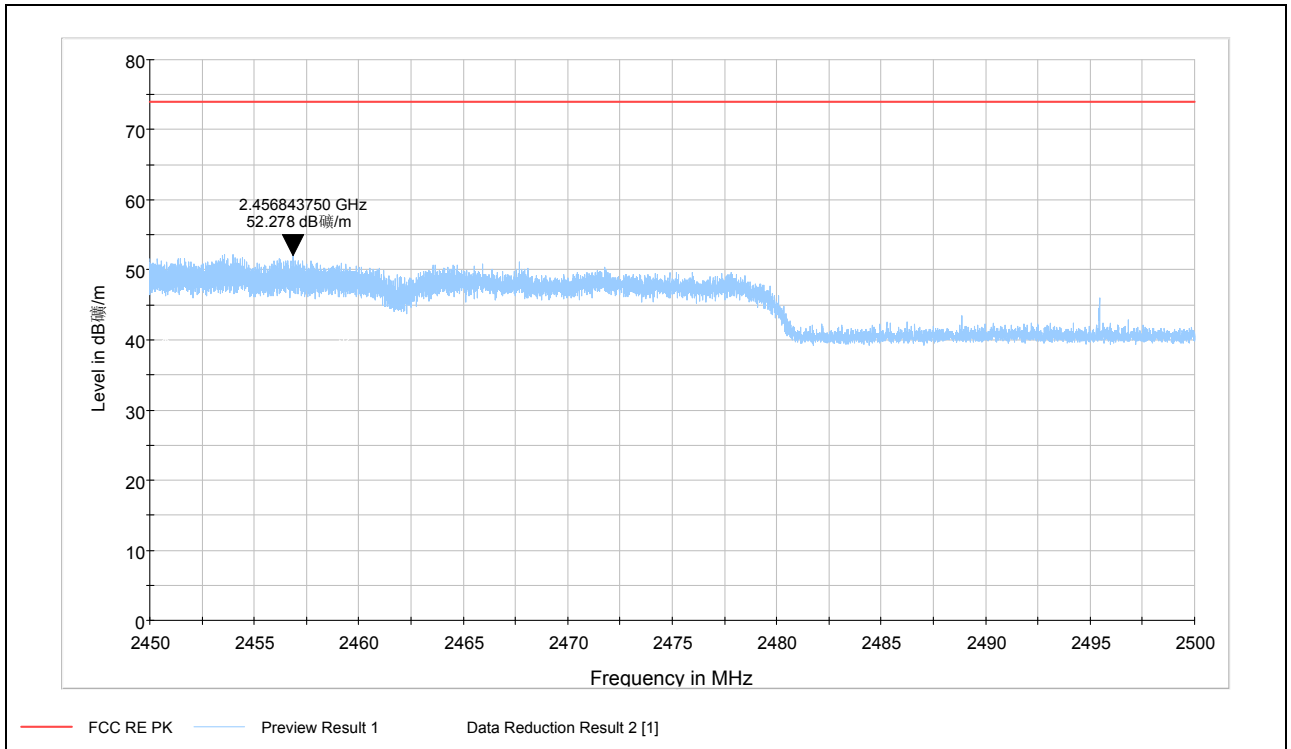

Note: The signal beyond the limit is carrier  
Channel 9

Average

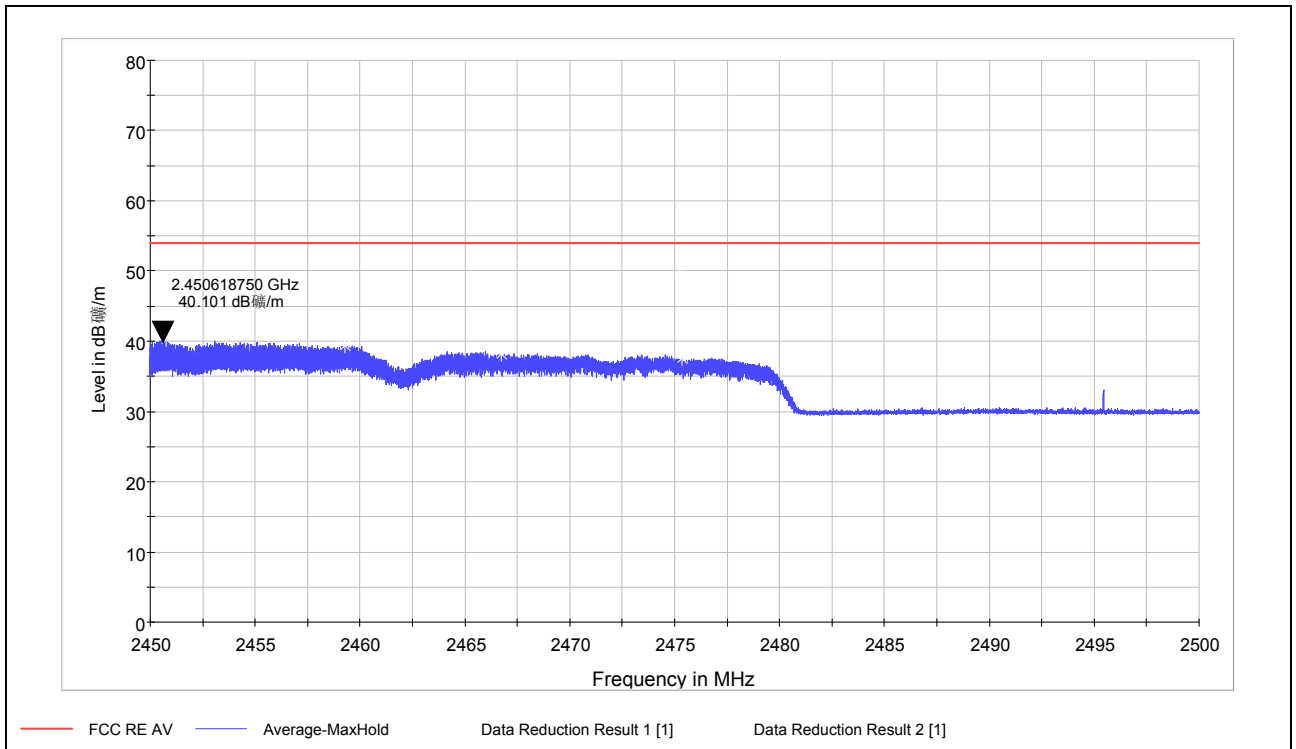

Note: The signal beyond the limit is carrier  
Channel 9



## 2.6. Power Spectral Density

### Ambient condition

Temperature	Relative humidity	Pressure
23°C ~25°C	45%~50%	101.5kPa

### Method of Measurement

The EUT was connected to the spectrum analyzer through an external attenuator (20dB) and a known loss cable. RBW is set to 3kHz and VBW is set to 30kHz on spectrum analyzer. Set the span is 300kHz and the sweep time is 100s. The peak power spectral density is recorded.

### Test setup

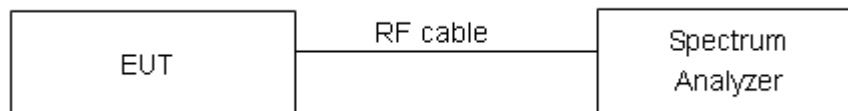

### Limits

Rule Part 15.247(e) specifies that” For digitally modulated systems, the power spectral density conducted from the intentional radiator to the antenna shall not be greater than 8 dBm in any 3 kHz band during any time interval of continuous transmission. ”

Limits	$\leq 8 \text{ dBm} / 3\text{kHz}$
--------	------------------------------------

### Measurement Uncertainty

The assessed measurement uncertainty to ensure 95% confidence level for the normal distribution is with the coverage factor  $k = 2$ ,  $U = 0.75\text{dB}$ .

**TA Technology (Shanghai) Co., Ltd.**  
**Test Report**

Report No.: RZA1202-0233RF01R2

Page 34 of 109

**Test Results:**

<b>Network Standards</b>	<b>Channel Number</b>	<b>Power Spectral Density dBm / 3kHz</b>	<b>Conclusion</b>
802.11b	1	-13.24	PASS
	6	-11.74	PASS
	11	-12.17	PASS
802.11g	1	-17.53	PASS
	6	-17.24	PASS
	11	-16.92	PASS
802.11n HT20	1	-15.97	PASS
	6	-14.94	PASS
	11	-17.05	PASS
802.11n HT40	3	-20.50	PASS
	6	-20.19	PASS
	9	-20.60	PASS

# TA Technology (Shanghai) Co., Ltd. Test Report

802.11b

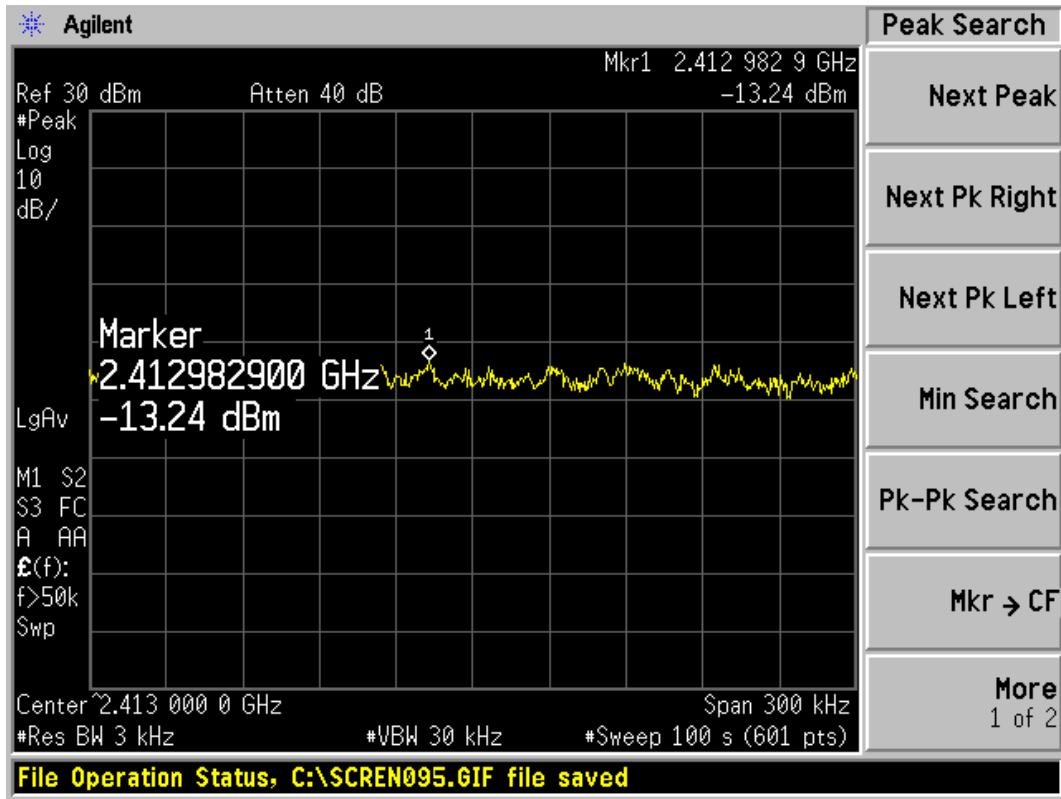

802.11b, Channel No.: 1

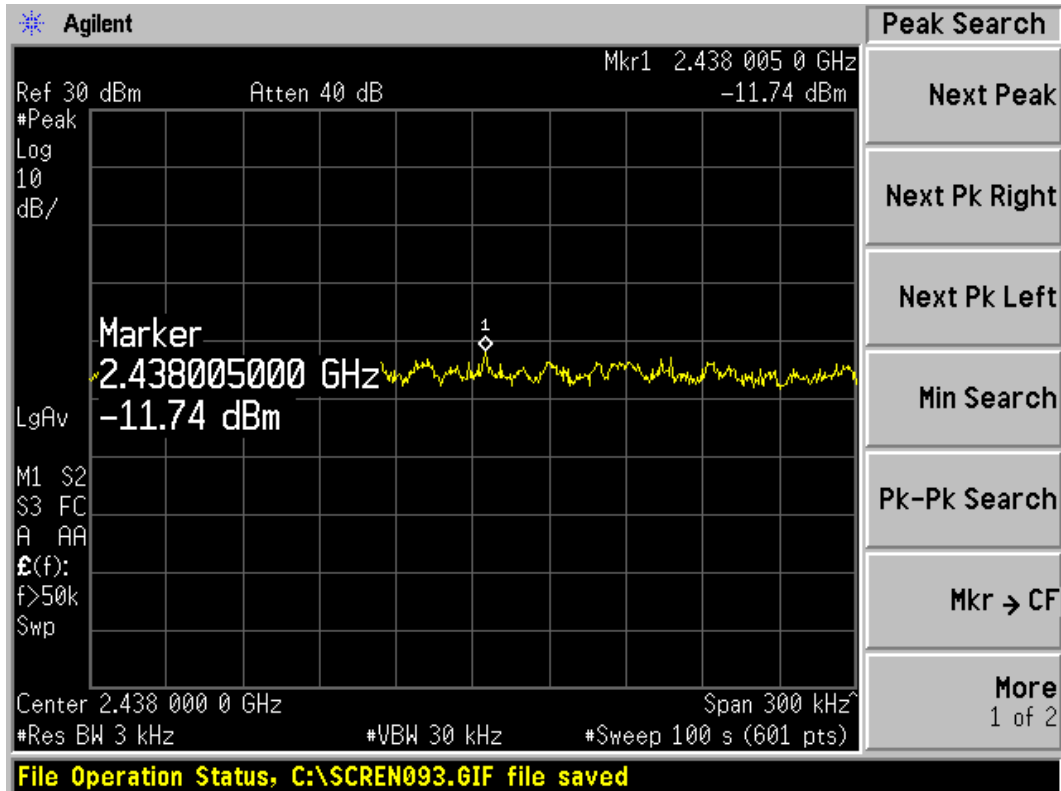

802.11b, Channel No.: 6

# TA Technology (Shanghai) Co., Ltd. Test Report

Report No.: RZA1202-0233RF01R2

Page 36 of 109

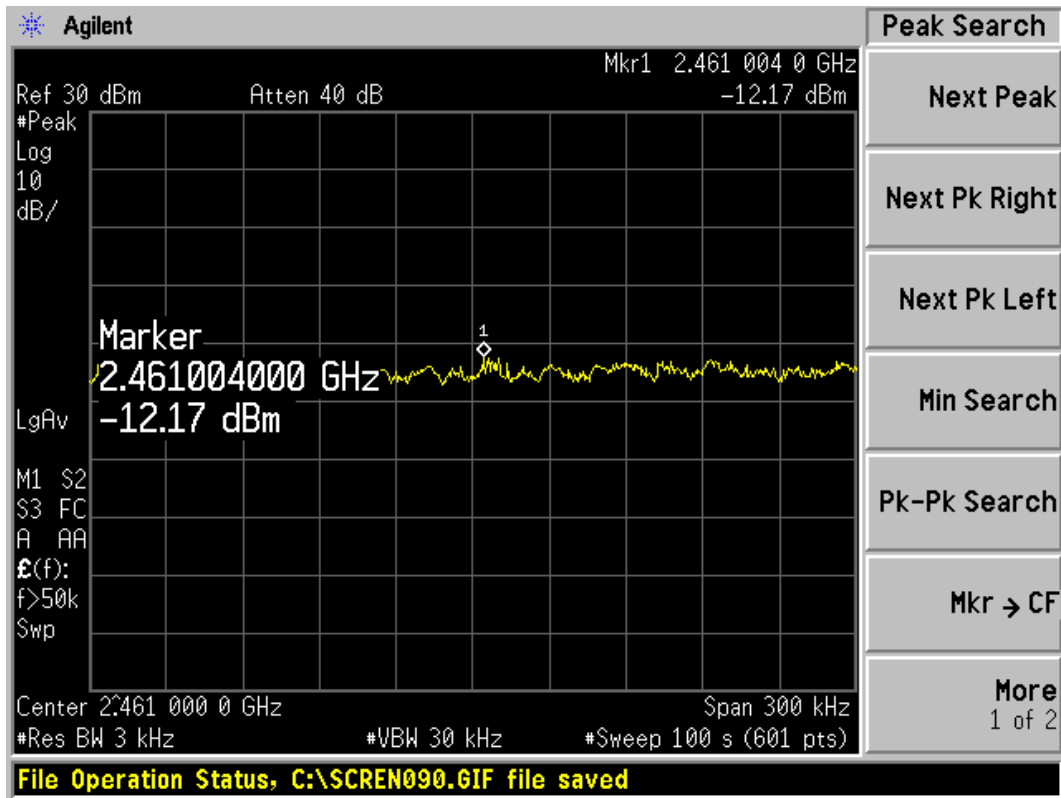

802.11b, Channel No.: 11

802.11g

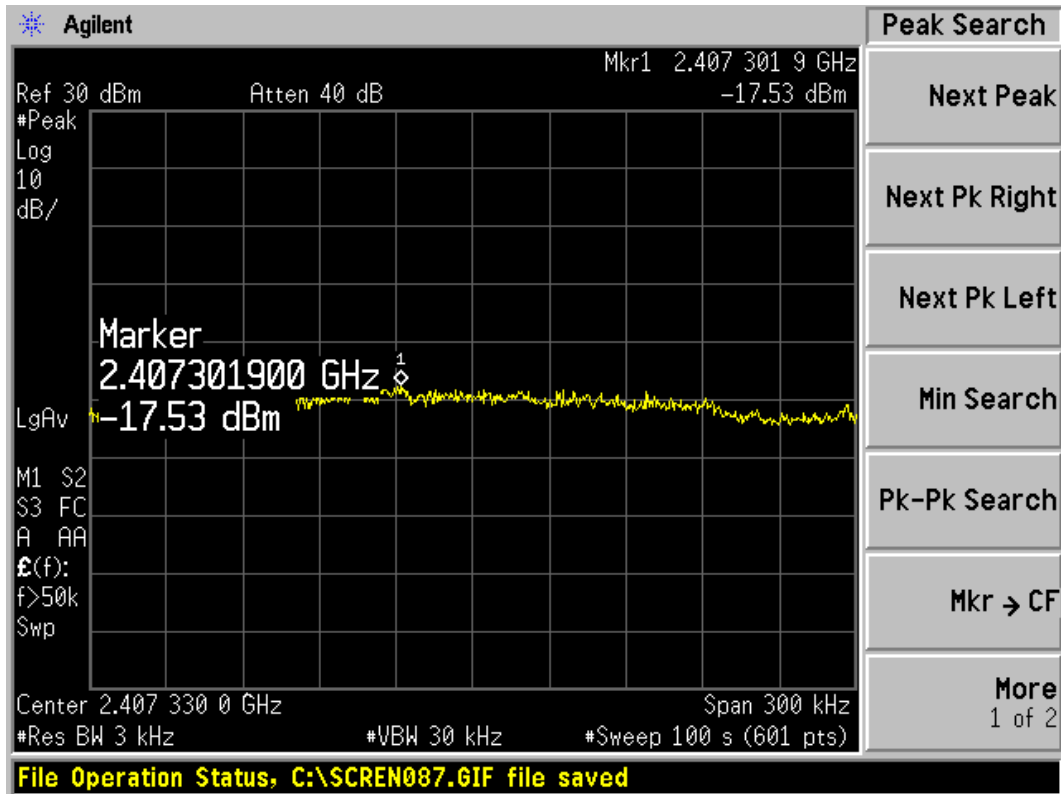

802.11g, Channel No.: 1

# TA Technology (Shanghai) Co., Ltd. Test Report

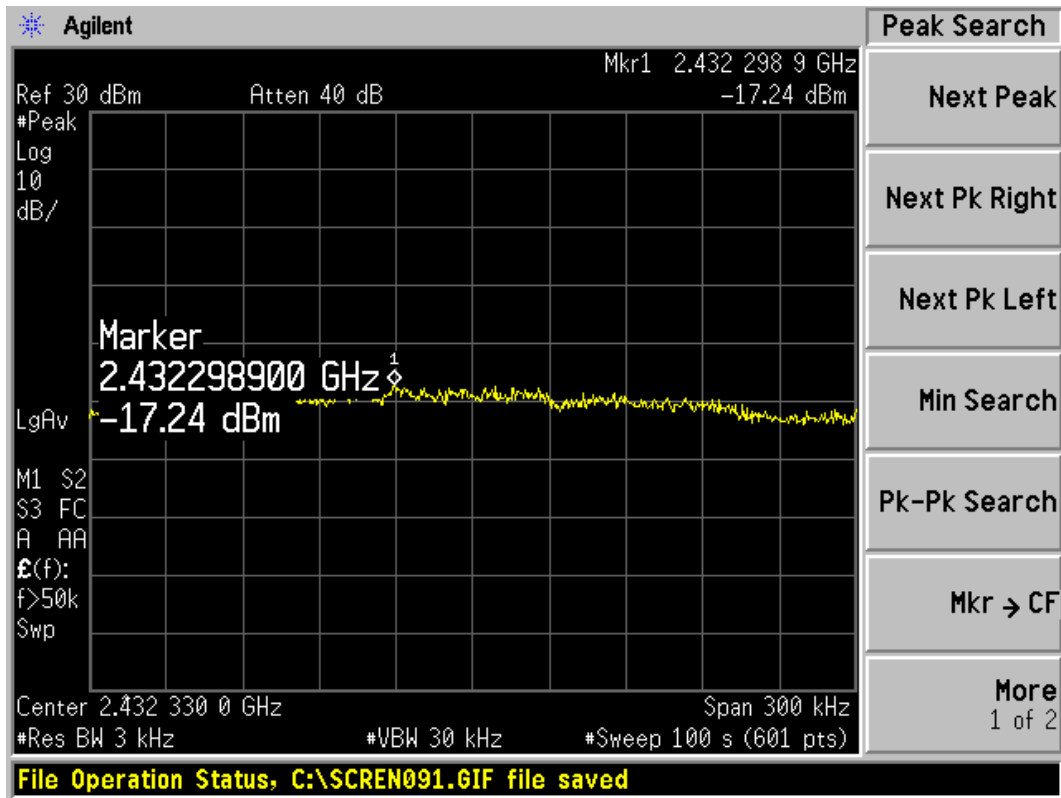

802.11g, Channel No.: 6

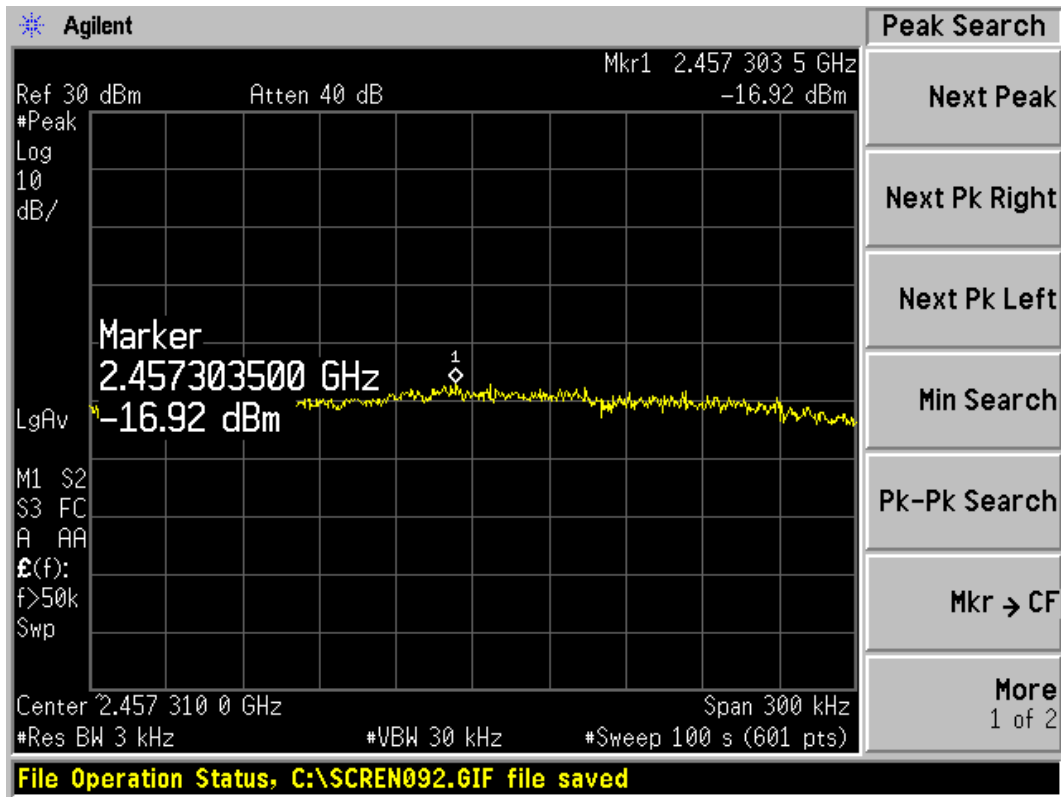

802.11g, Channel No.: 11

TA Technology (Shanghai) Co., Ltd.  
Test Report

802.11n HT20

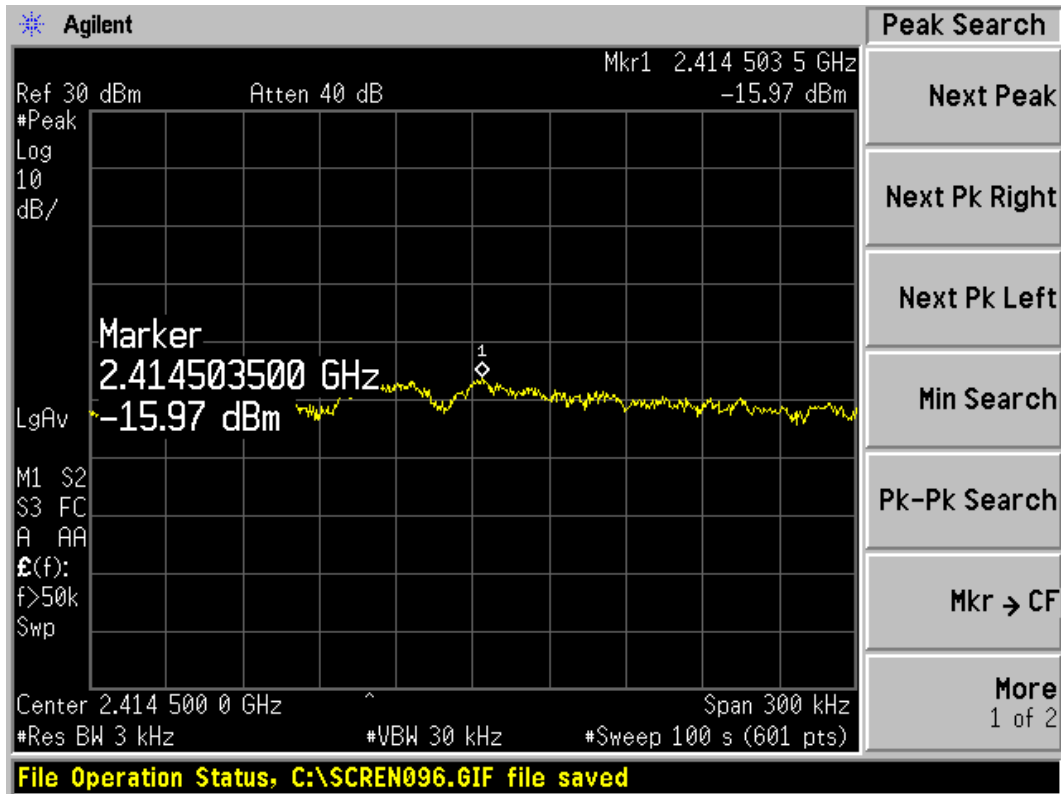

802.11n HT20, Channal No.: 1

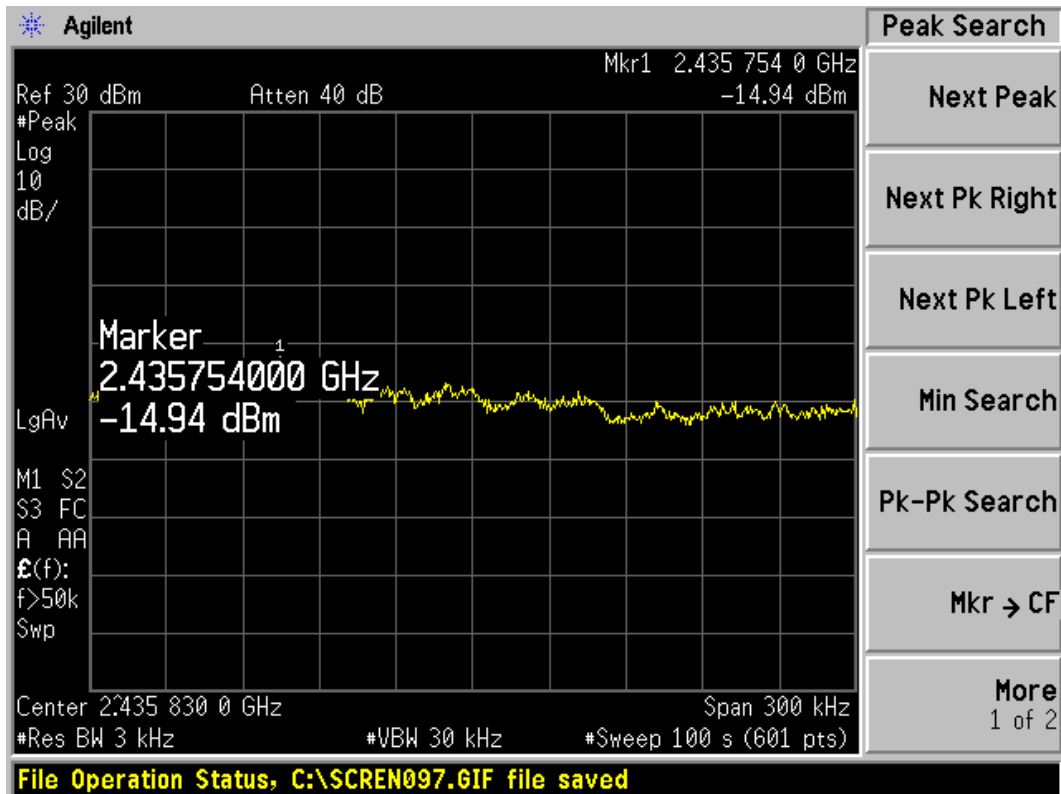

802.11n HT20, Channal No.: 6

# TA Technology (Shanghai) Co., Ltd. Test Report

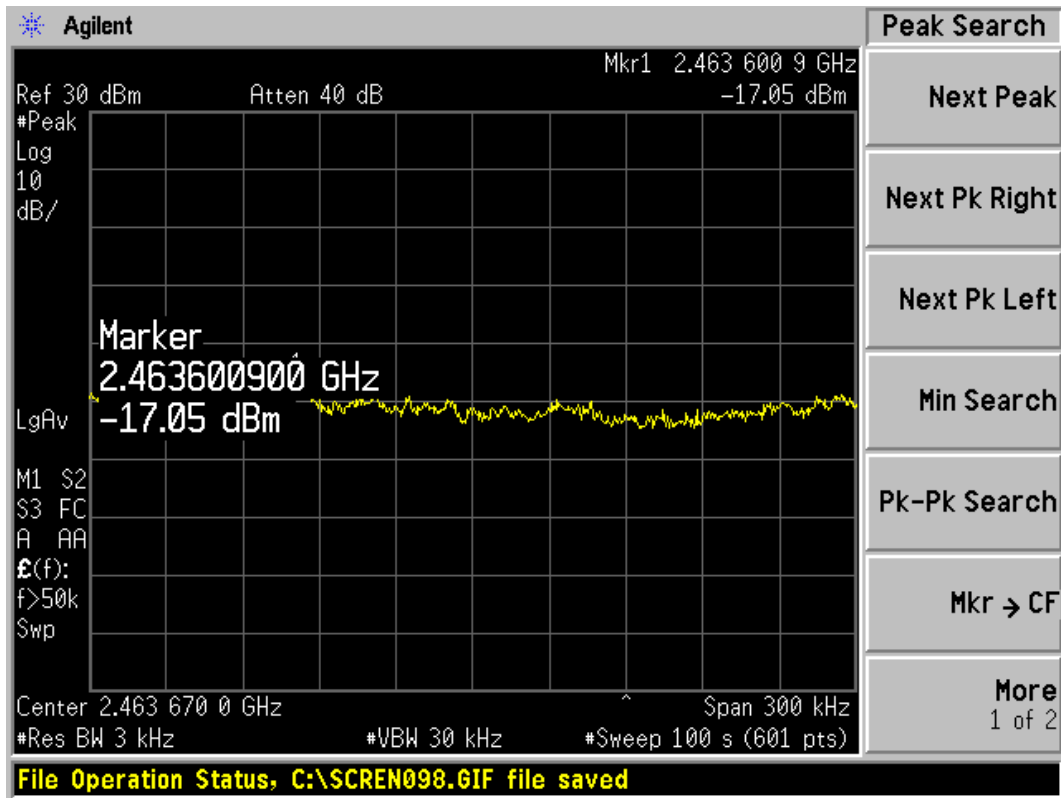

802.11n HT20, Channal No.: 11

802.11n HT40

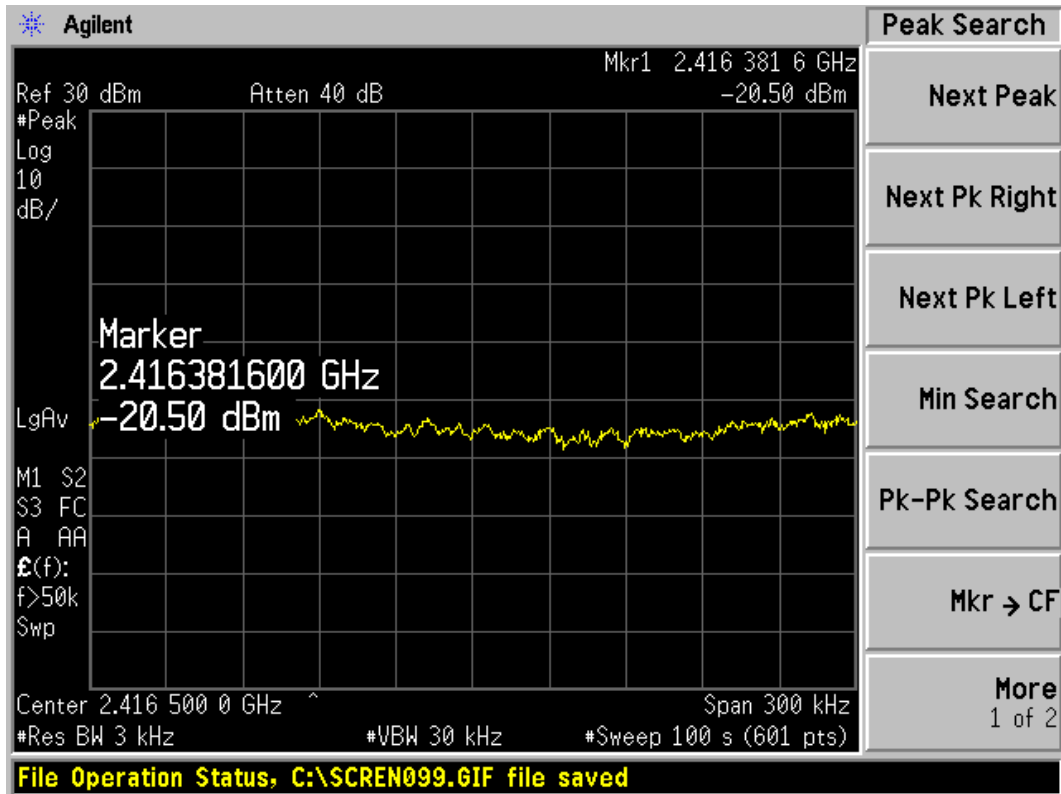

802.11n HT40, Channal No.: 3

TA Technology (Shanghai) Co., Ltd.  
Test Report

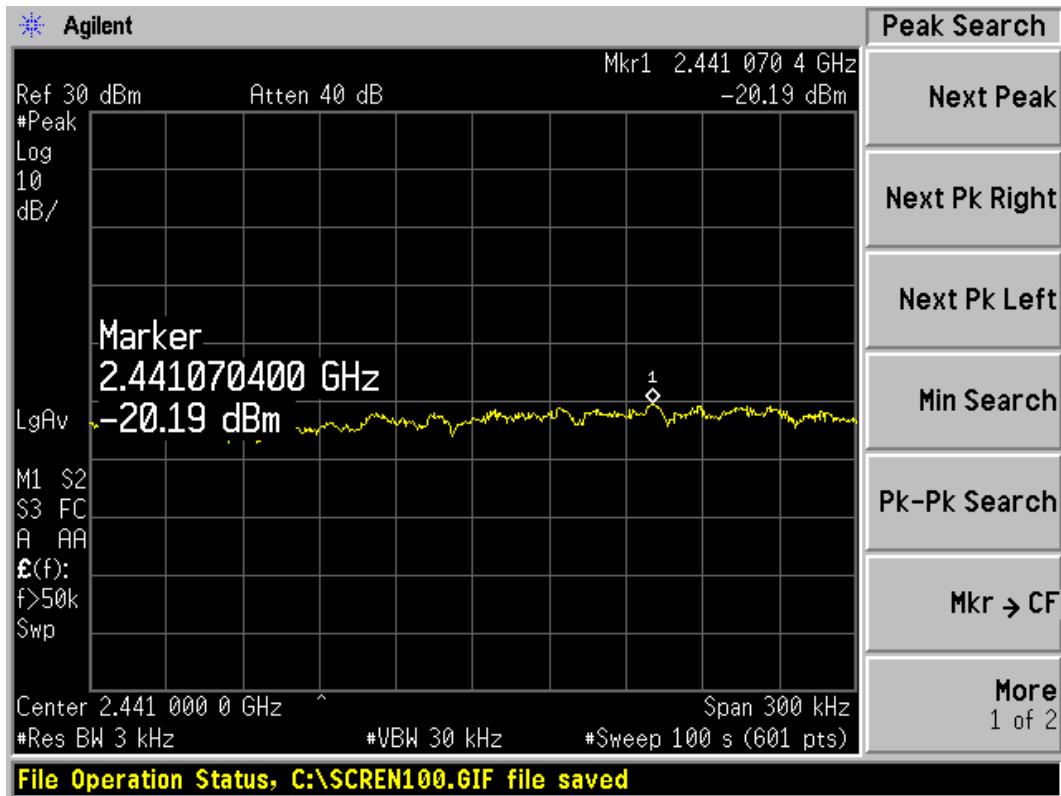

802.11n HT40, Channal No.: 6

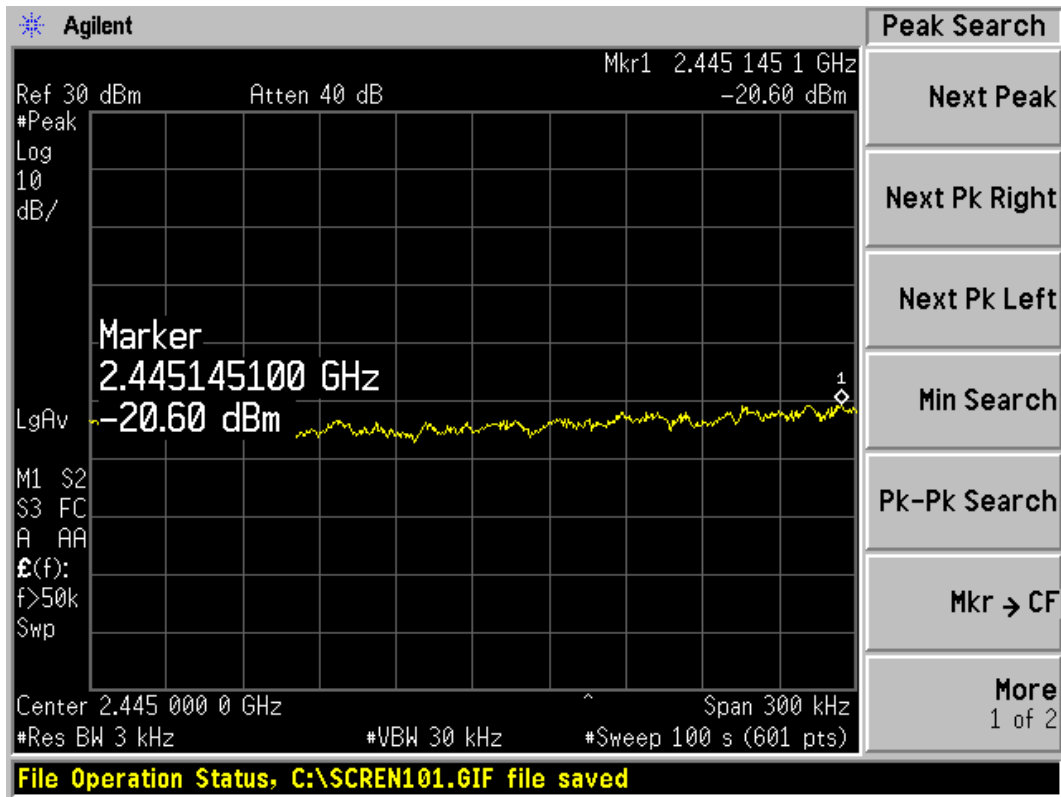

802.11n HT40, Channal No.: 9



## 2.7. Spurious RF Conducted Emissions

### Ambient condition

Temperature	Relative humidity	Pressure
23°C ~25°C	45%~50%	101.5kPa

### Method of Measurement

The EUT was connected to the spectrum analyzer and Bluetooth test set via a power splitter with a known loss. The spectrum analyzer scans from 30MHz to 26.5GHz. The peak detector is used. RBW and VBW are set to 100 kHz. Sweep is set to ATUO.

The test is in transmitting mode.

### Test setup



### Limits

Rule Part 15.247(d) specifies that “In any 100 kHz bandwidth outside the frequency band in which the spread spectrum intentional radiator is operating, the radio frequency power that is produced by the intentional radiator shall be at least 20 dB below that in the 100 kHz bandwidth within the band that contains the highest level of the desired power.”

Network Standards	Carrier frequency (MHz)	Reference value (dBm)	Limit
802.11b	2412	17.25	≤-2.75
	2437	17.38	≤-2.62
	2462	16.68	≤-3.32
802.11g	2412	14.24	≤-5.76
	2437	14.64	≤-5.36
	2462	14.25	≤-5.75
802.11n HT20	2412	14.04	≤-5.96
	2437	14.54	≤-5.46
	2462	13.85	≤-6.15

**TA Technology (Shanghai) Co., Ltd.**  
**Test Report**

Report No.: RZA1202-0233RF01R2

Page 42 of 109

802.11n HT40	2422	14.23	$\leq -5.77$
	2437	14.92	$\leq -5.08$
	2452	14.95	$\leq -5.05$

**Measurement Uncertainty**

The assessed measurement uncertainty to ensure 95% confidence level for the normal distribution is with the coverage factor  $k = 1.96$ .

Frequency	Uncertainty
100kHz-2GHz	0.684 dB
2GHz-26.5GHz	1.407 dB

# TA Technology (Shanghai) Co., Ltd. Test Report

Report No.: RZA1202-0233RF01R2

Page 43of 109

## Test Results:

802.11b CH1

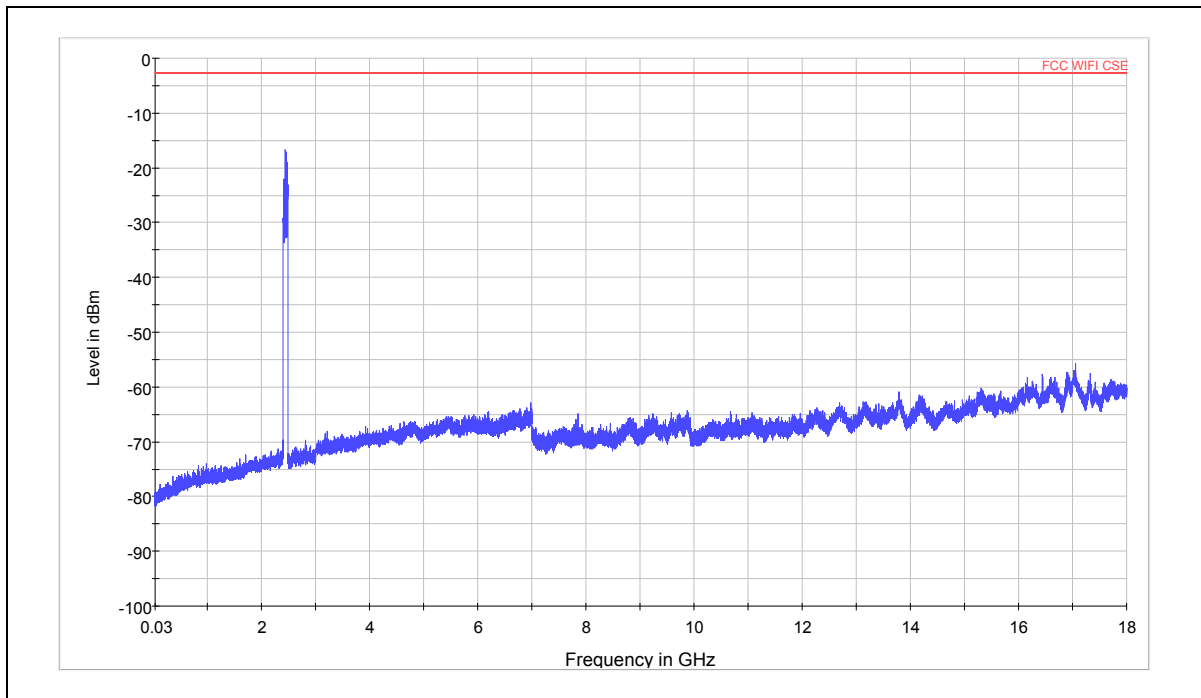

Note: The signal beyond the limit is carrier

Spurious RF conducted emissions from 30MHz to 18GHz

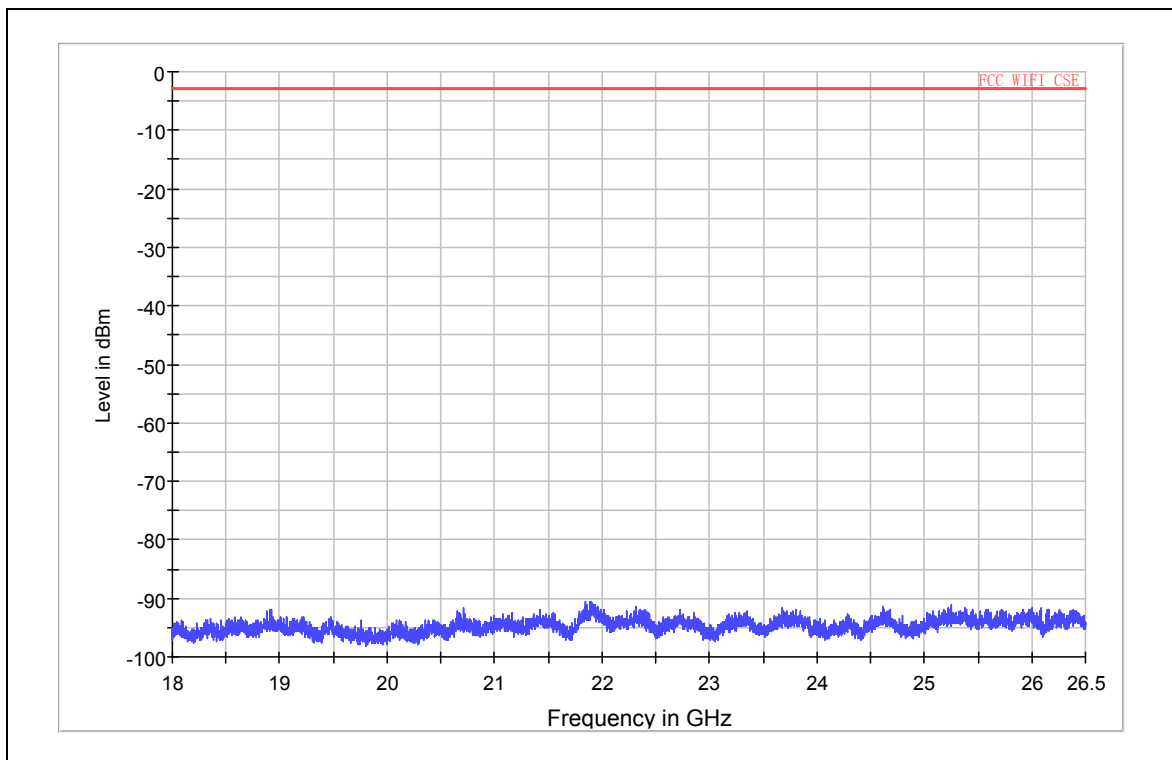

Spurious RF conducted emissions from 18GHz to 26.5GHz

# TA Technology (Shanghai) Co., Ltd. Test Report

Report No.: RZA1202-0233RF01R2

Page 44 of 109

802.11b CH6

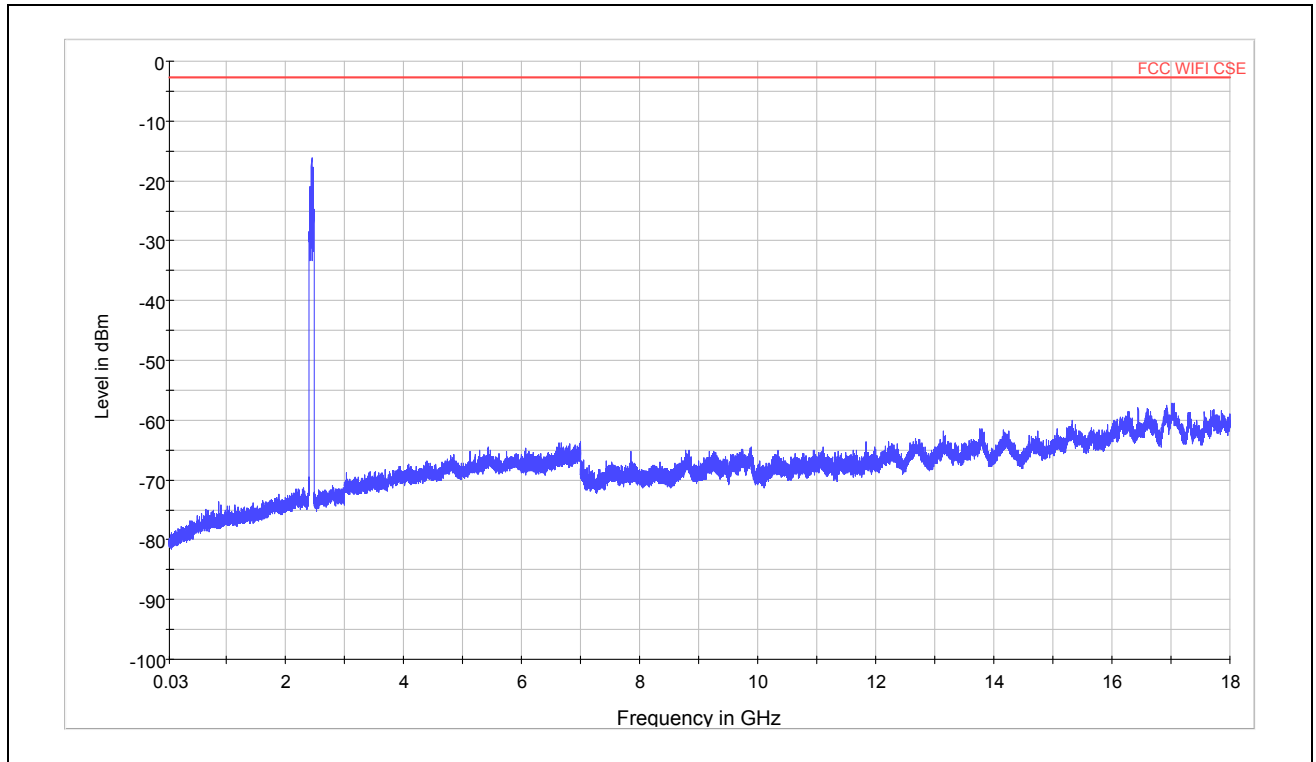

Note: The signal beyond the limit is carrier

Spurious RF conducted emissions from 30MHz to 18GHz

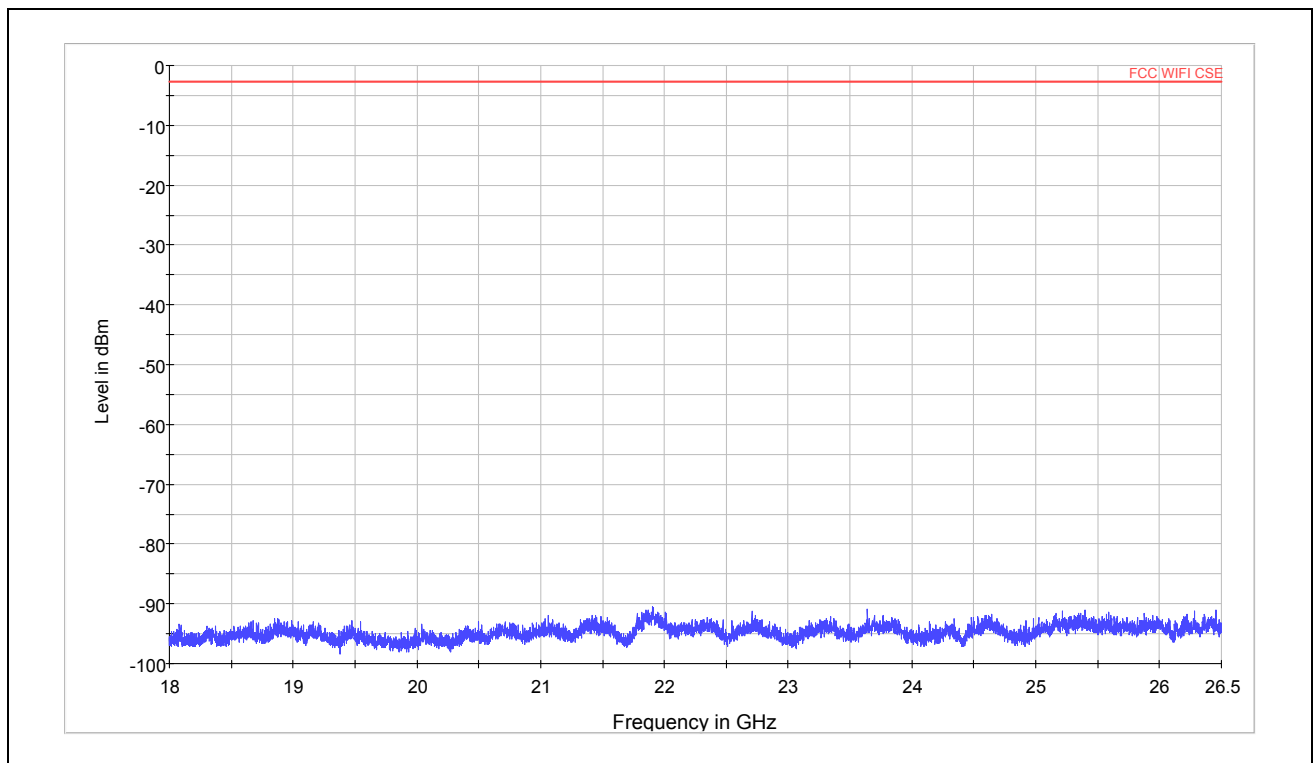

Spurious RF conducted emissions from 18GHz to 26.5GHz

# TA Technology (Shanghai) Co., Ltd. Test Report

Report No.: RZA1202-0233RF01R2

Page 45 of 109

802.11b CH11

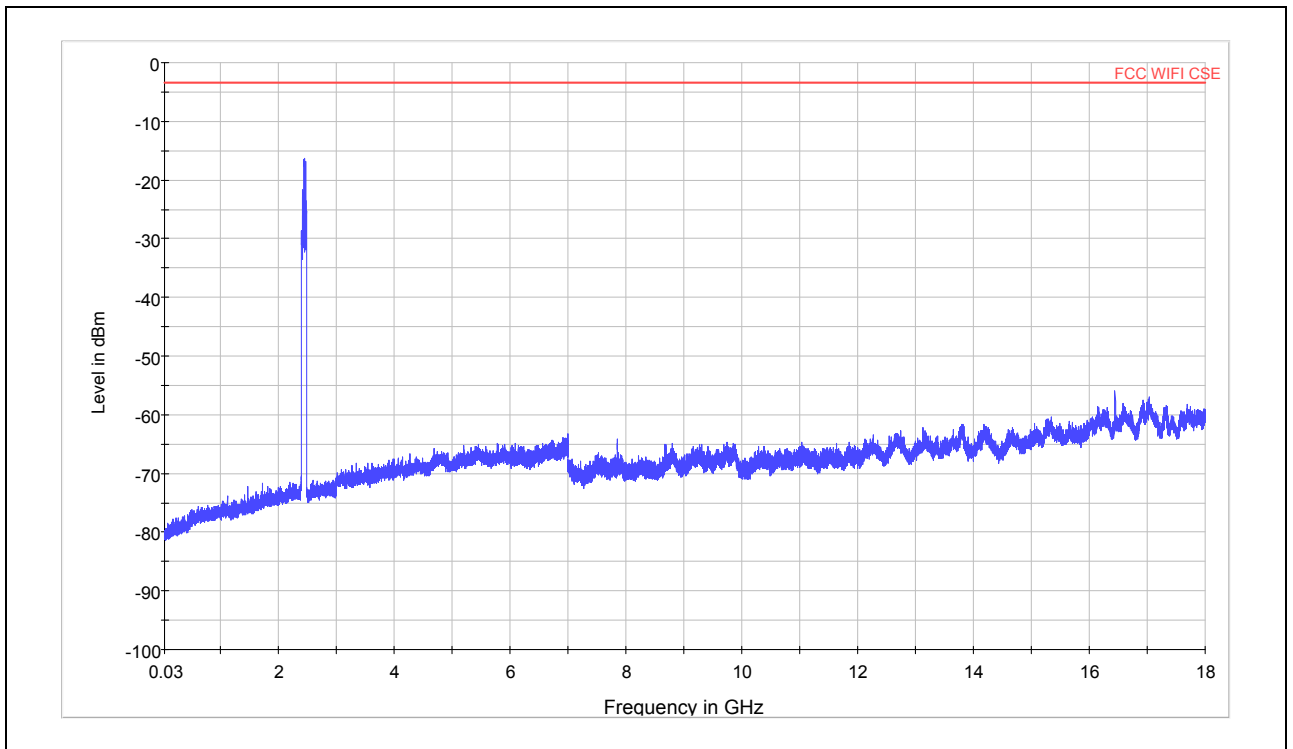

Note: The signal beyond the limit is carrier

Spurious RF conducted emissions from 30MHz to 18GHz

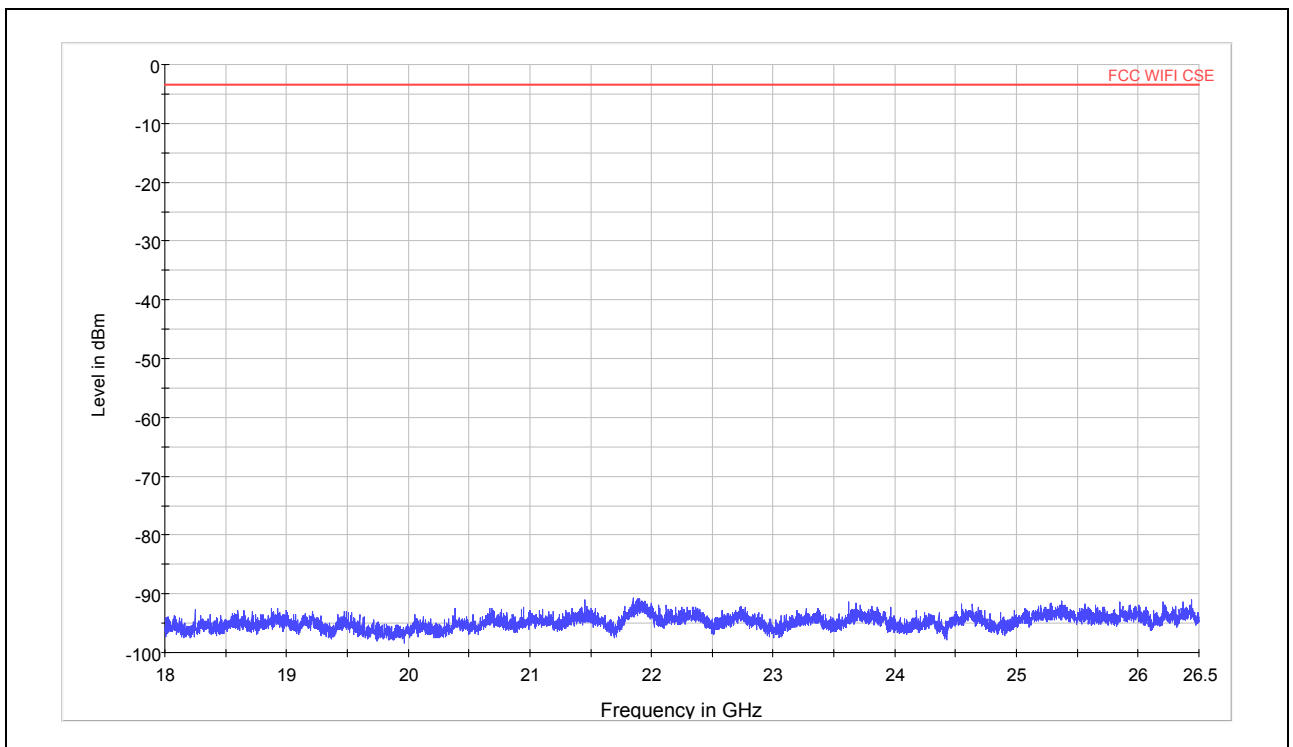

Spurious RF conducted emissions from 18GHz to 26.5GHz

# TA Technology (Shanghai) Co., Ltd. Test Report

Report No.: RZA1202-0233RF01R2

Page 46 of 109

802.11g CH1

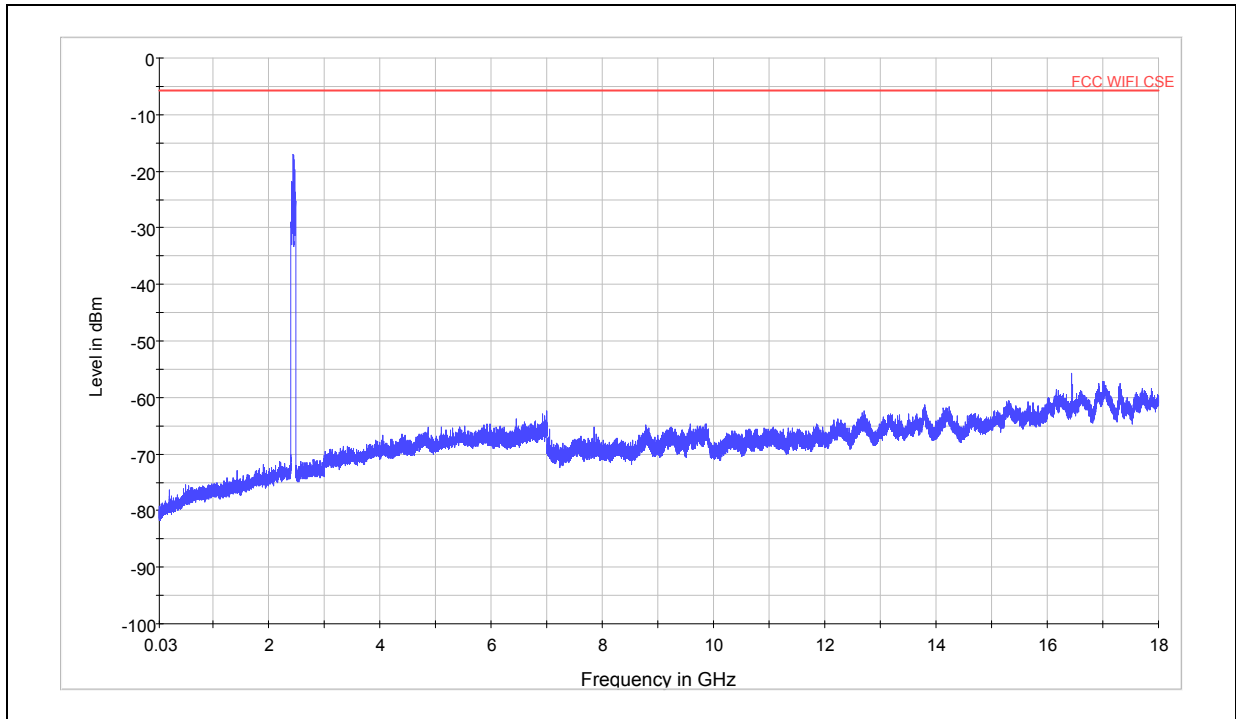

Note: The signal beyond the limit is carrier

Spurious RF conducted emissions from 30MHz to 18GHz

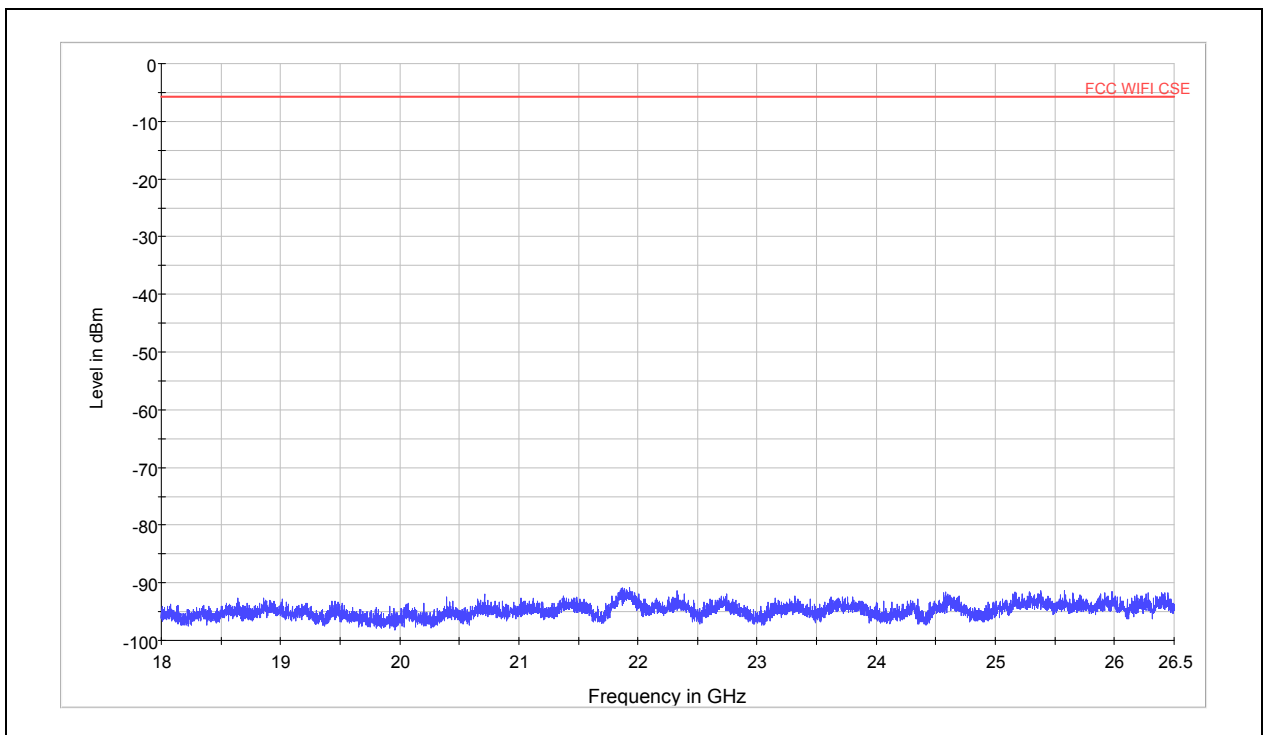

Spurious RF conducted emissions from 18GHz to 26.5GHz

# TA Technology (Shanghai) Co., Ltd. Test Report

Report No.: RZA1202-0233RF01R2

Page 47 of 109

802.11g CH6

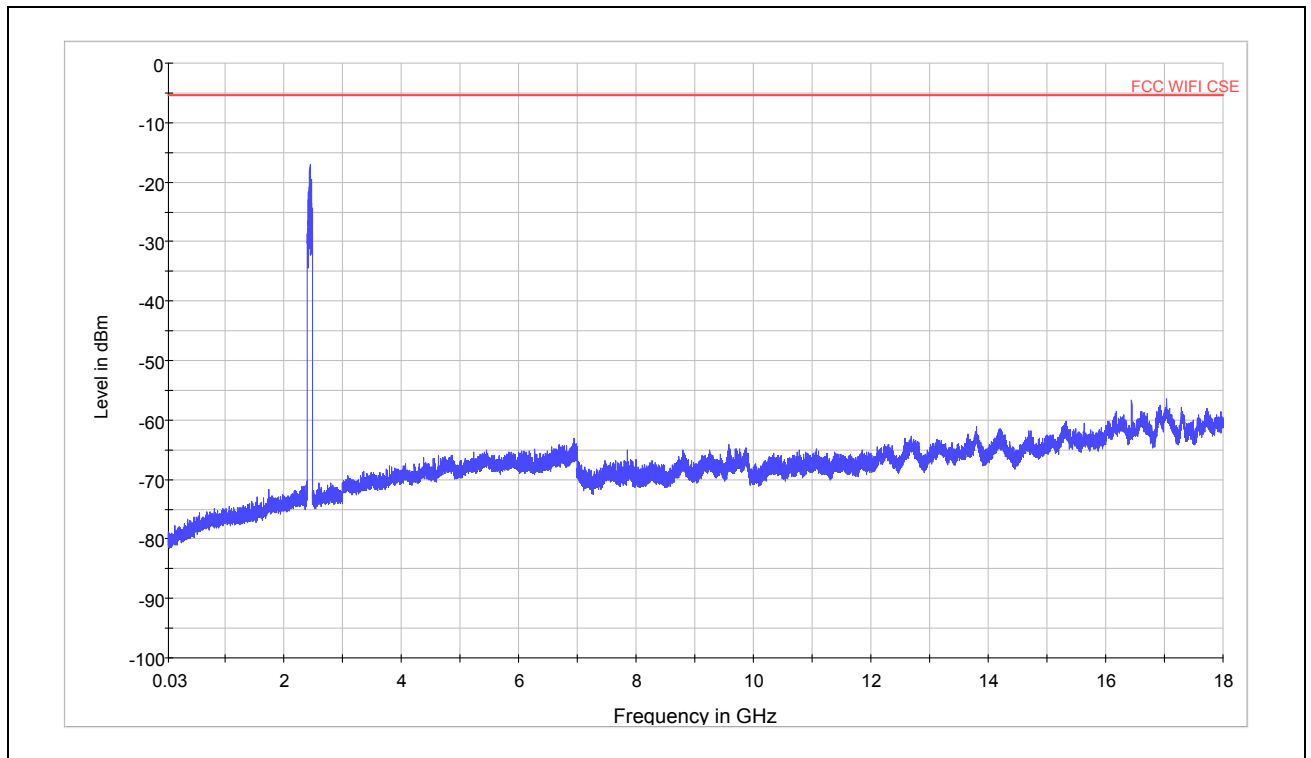

Note: The signal beyond the limit is carrier

Spurious RF conducted emissions from 30MHz to 18GHz

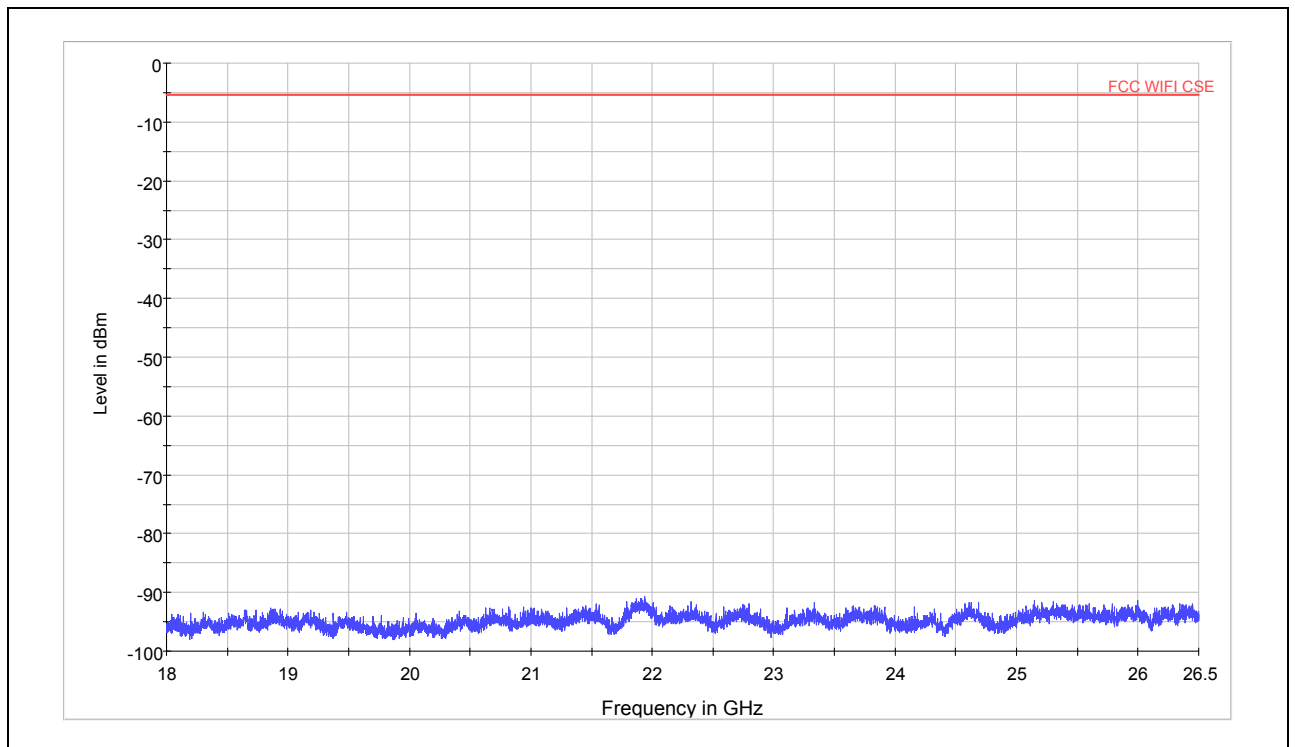

Spurious RF conducted emissions from 18GHz to 26.5GHz

# TA Technology (Shanghai) Co., Ltd. Test Report

Report No.: RZA1202-0233RF01R2

Page 48 of 109

802.11g CH11

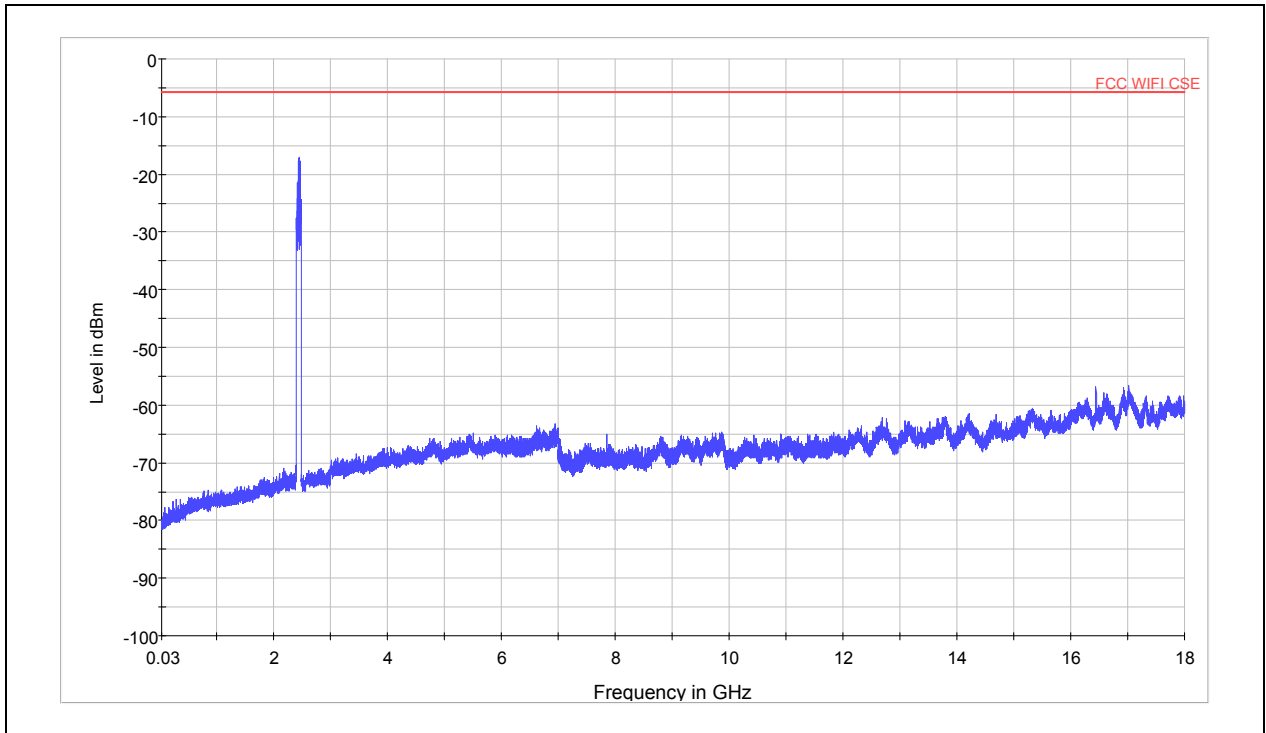

Note: The signal beyond the limit is carrier

Spurious RF conducted emissions from 30MHz to 18GHz

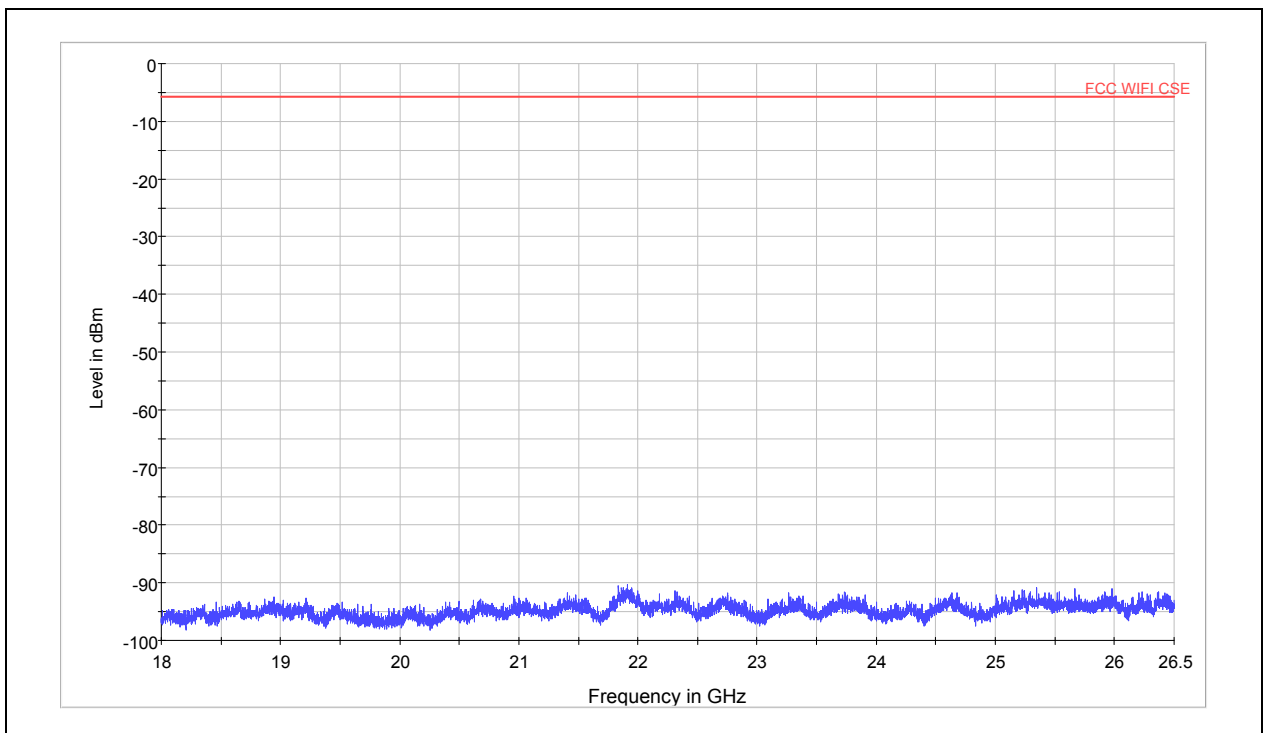

Spurious RF conducted emissions from 18GHz to 26.5GHz



# TA Technology (Shanghai) Co., Ltd. Test Report

Report No.: RZA1202-0233RF01R2

Page 49 of 109

802.11n HT20 CH1

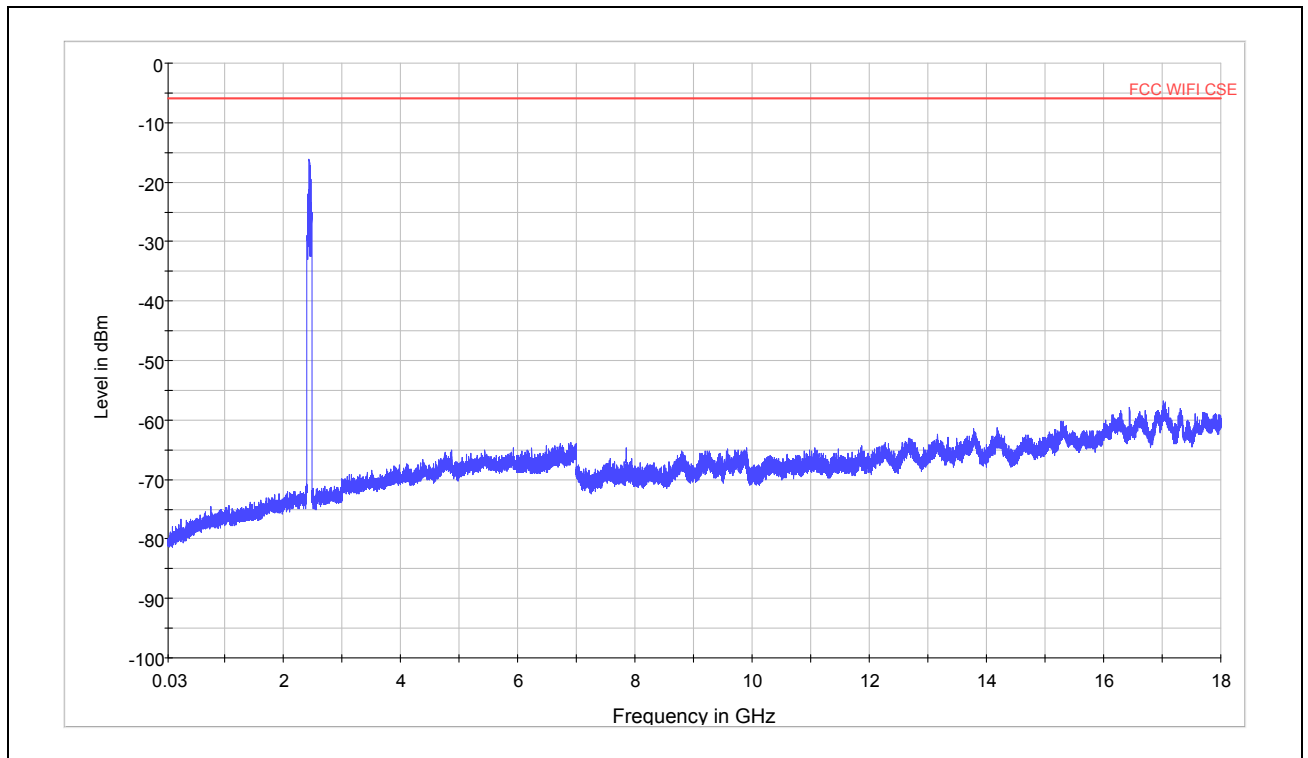

Note: The signal beyond the limit is carrier

Spurious RF conducted emissions from 30MHz to 18GHz

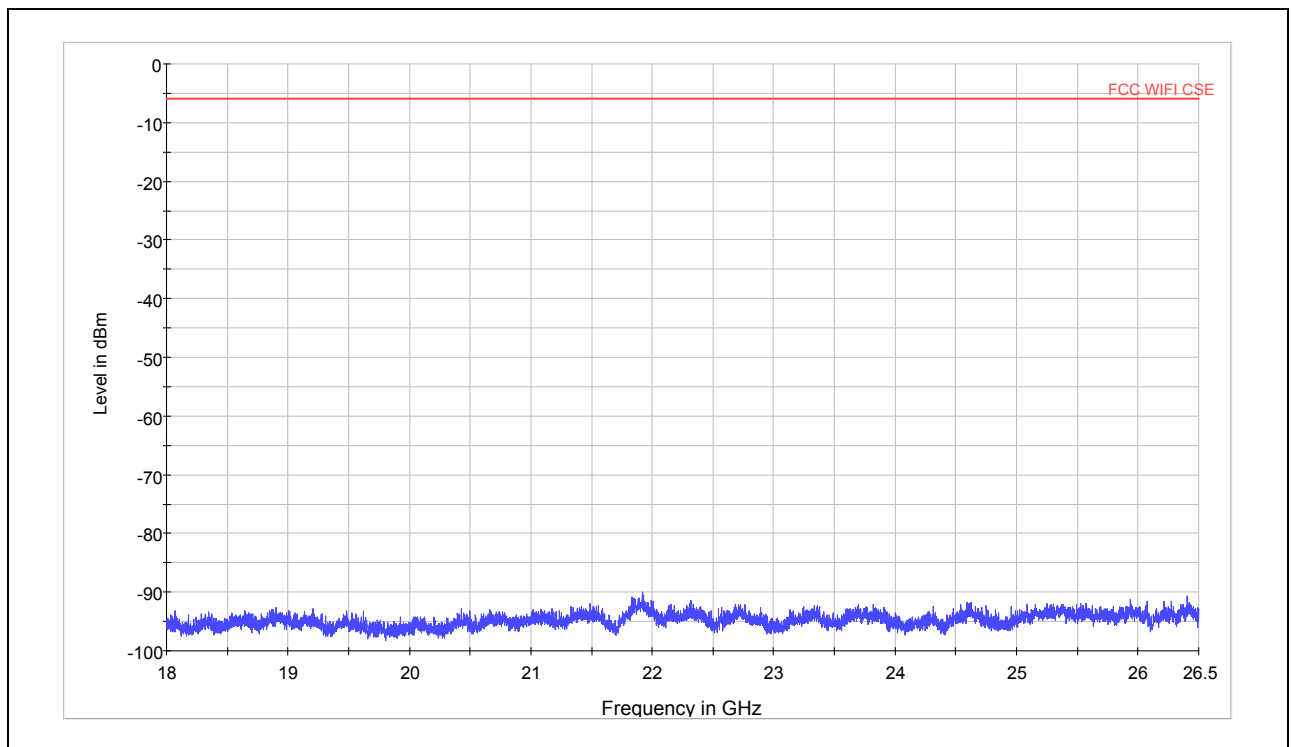

Spurious RF conducted emissions from 18GHz to 26.5GHz

# TA Technology (Shanghai) Co., Ltd. Test Report

802.11n HT20 CH6

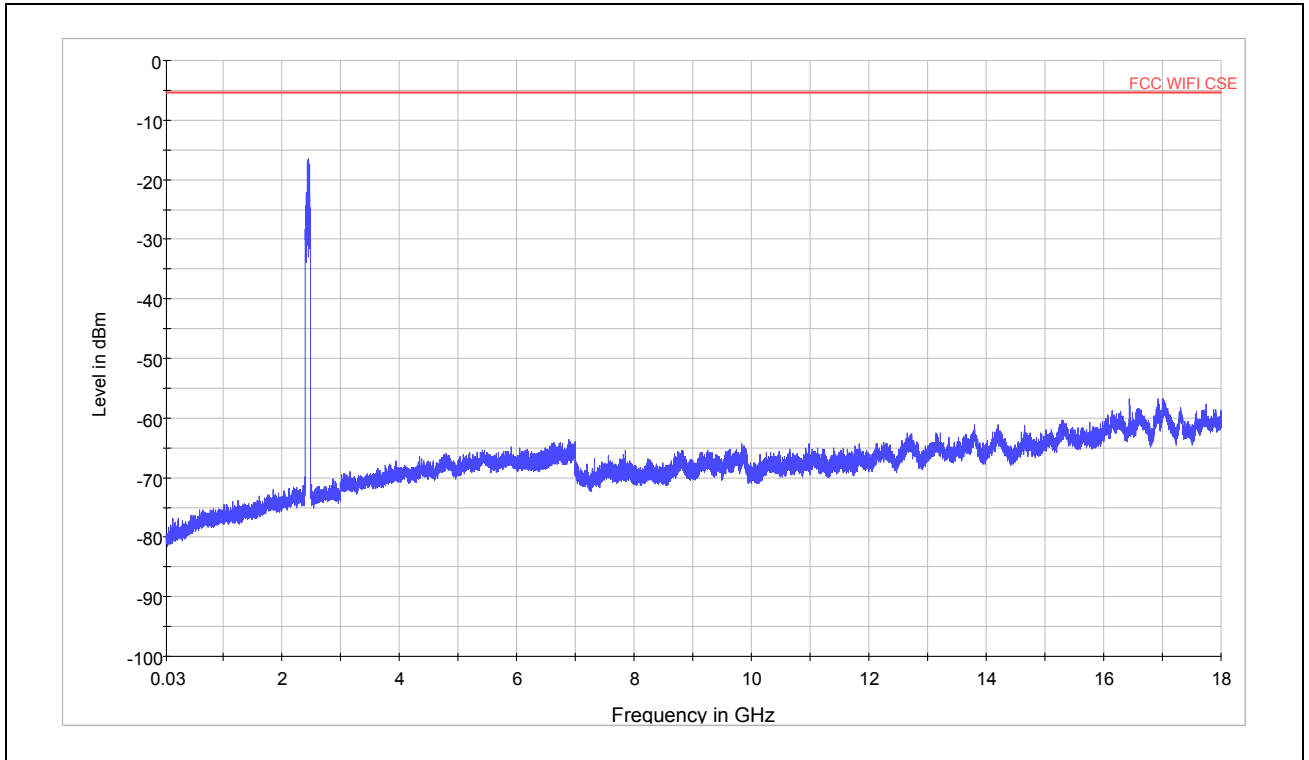

Note: The signal beyond the limit is carrier

Spurious RF conducted emissions from 30MHz to 18GHz

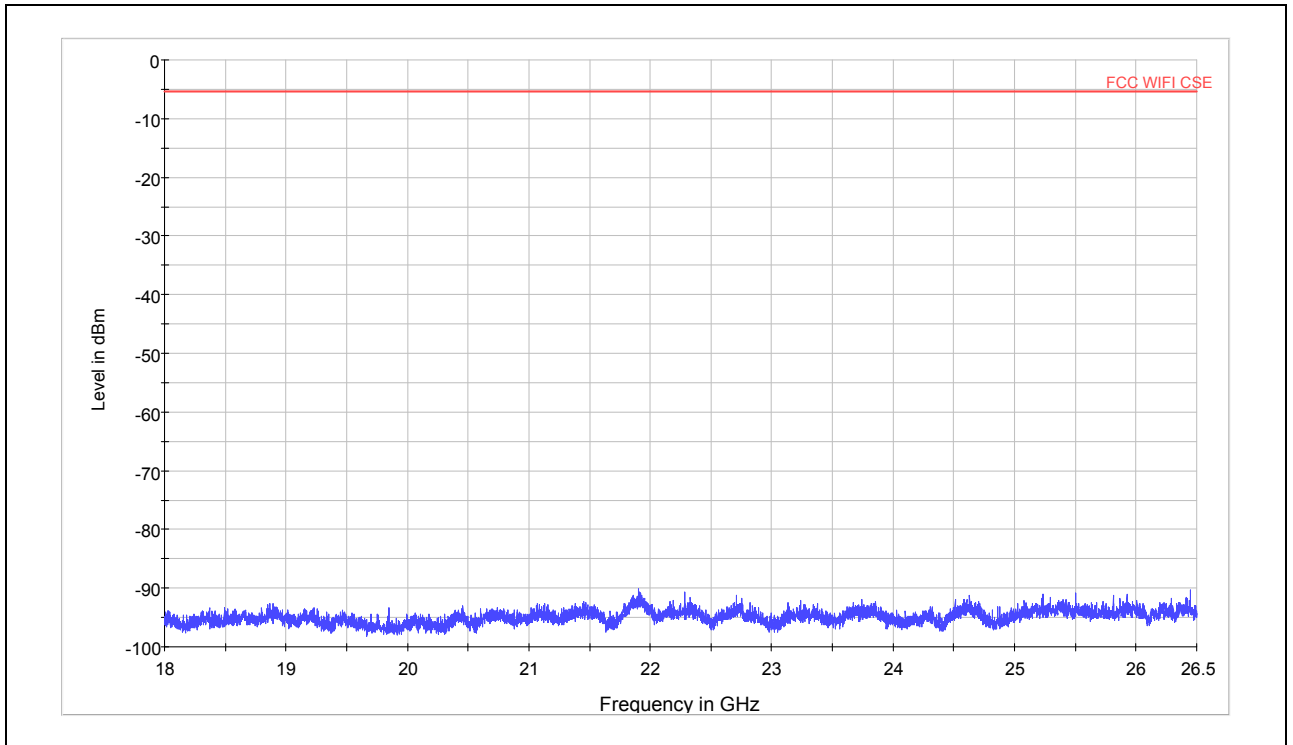

Spurious RF conducted emissions from 18GHz to 26.5GHz

# TA Technology (Shanghai) Co., Ltd. Test Report

Report No.: RZA1202-0233RF01R2

Page 51 of 109

802.11n HT20 CH11

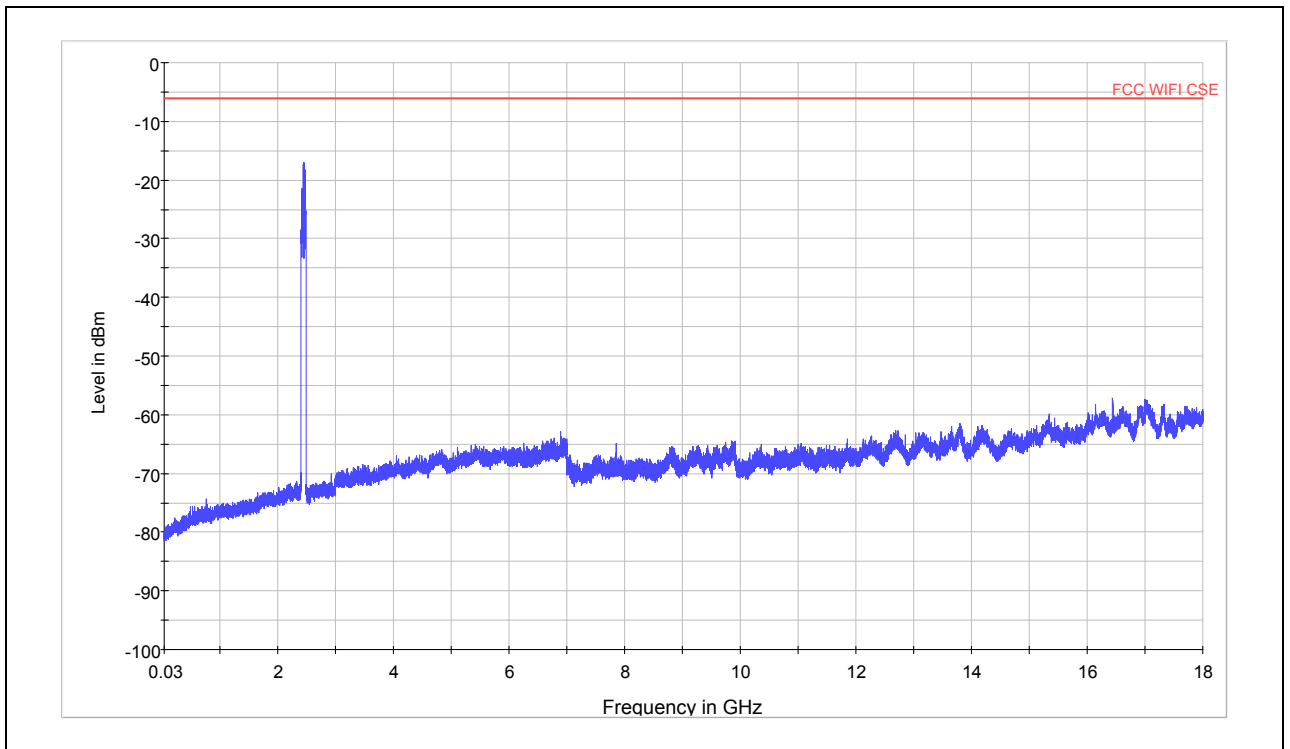

Note: The signal beyond the limit is carrier

Spurious RF conducted emissions from 30MHz to 18GHz

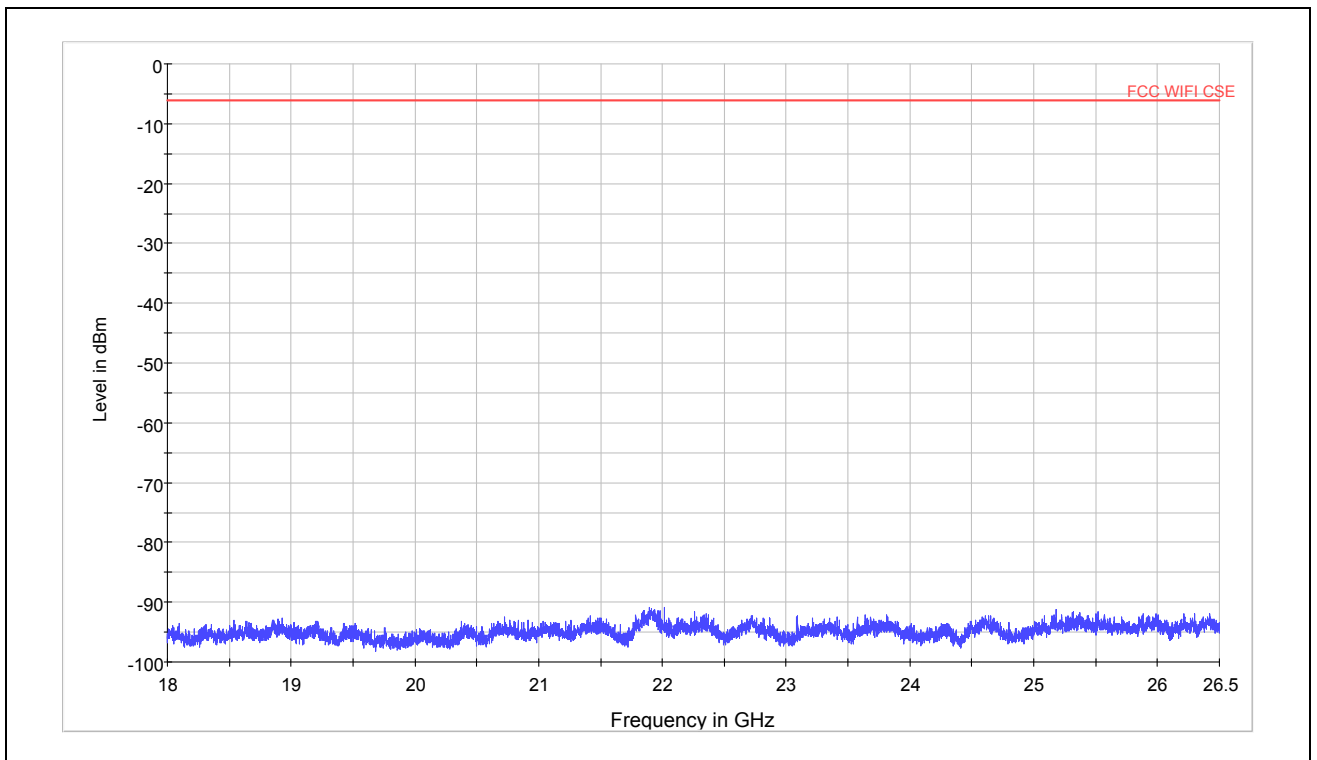

Spurious RF conducted emissions from 18GHz to 26.5GHz

# TA Technology (Shanghai) Co., Ltd. Test Report

Report No.: RZA1202-0233RF01R2

Page 52 of 109

802.11n HT40 CH3

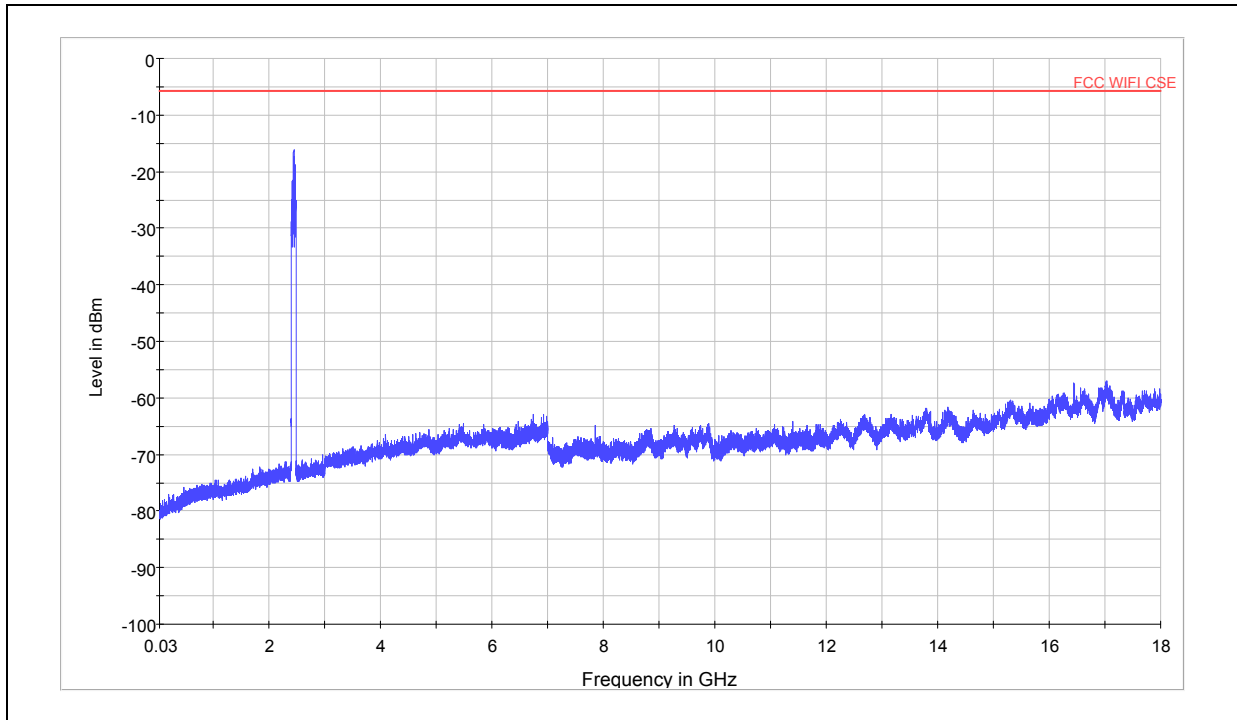

Note: The signal beyond the limit is carrier

Spurious RF conducted emissions from 30MHz to 18GHz

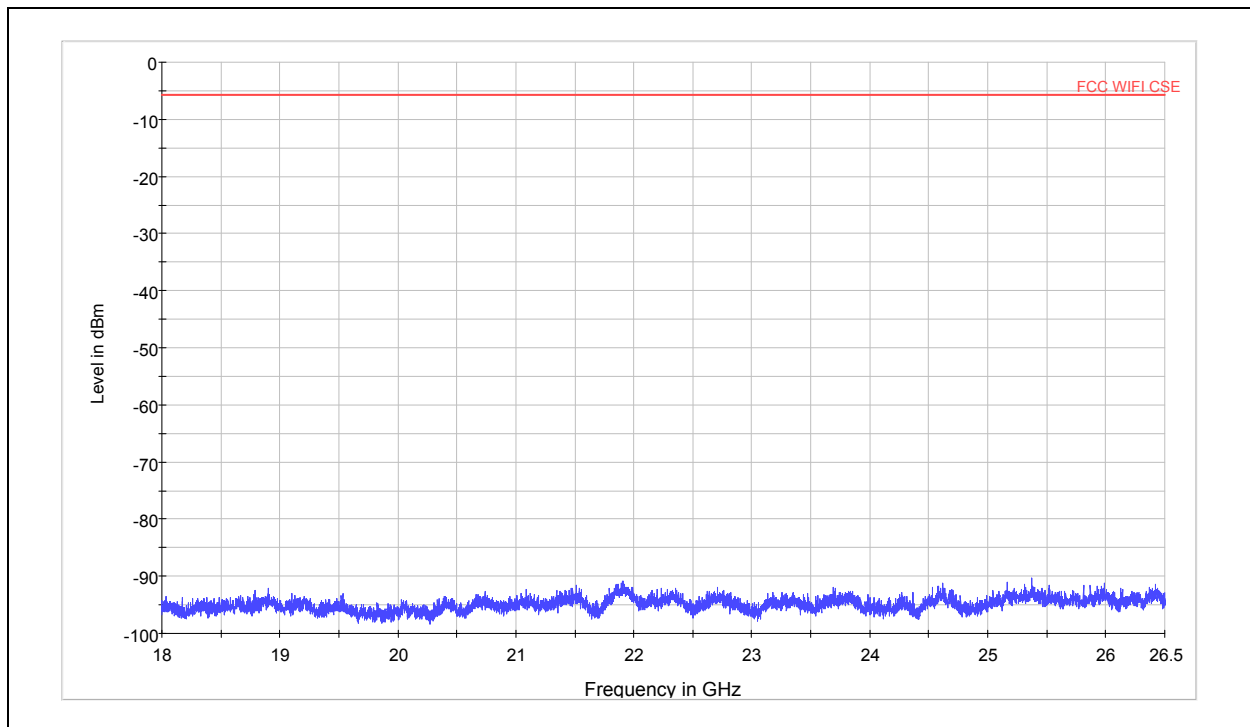

Spurious RF conducted emissions from 18GHz to 26.5GHz

# TA Technology (Shanghai) Co., Ltd. Test Report

Report No.: RZA1202-0233RF01R2

Page 53 of 109

802.11n HT40 CH6

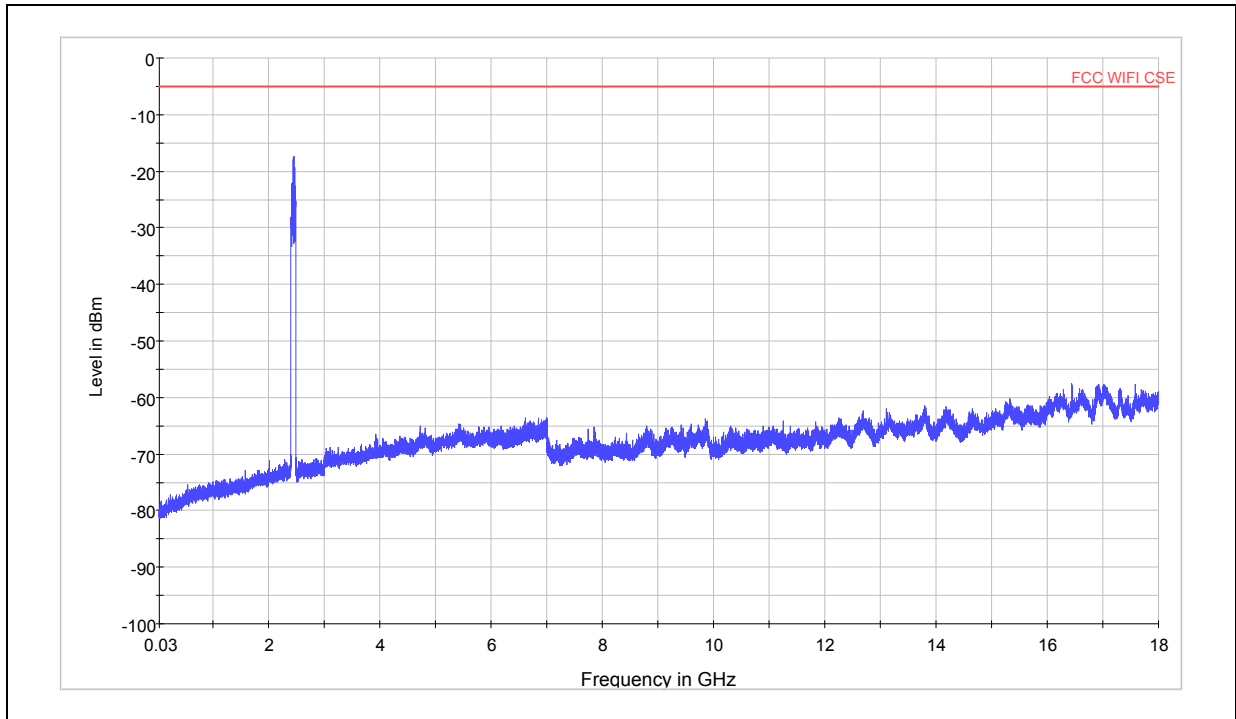

Note: The signal beyond the limit is carrier

Spurious RF conducted emissions from 30MHz to 18GHz

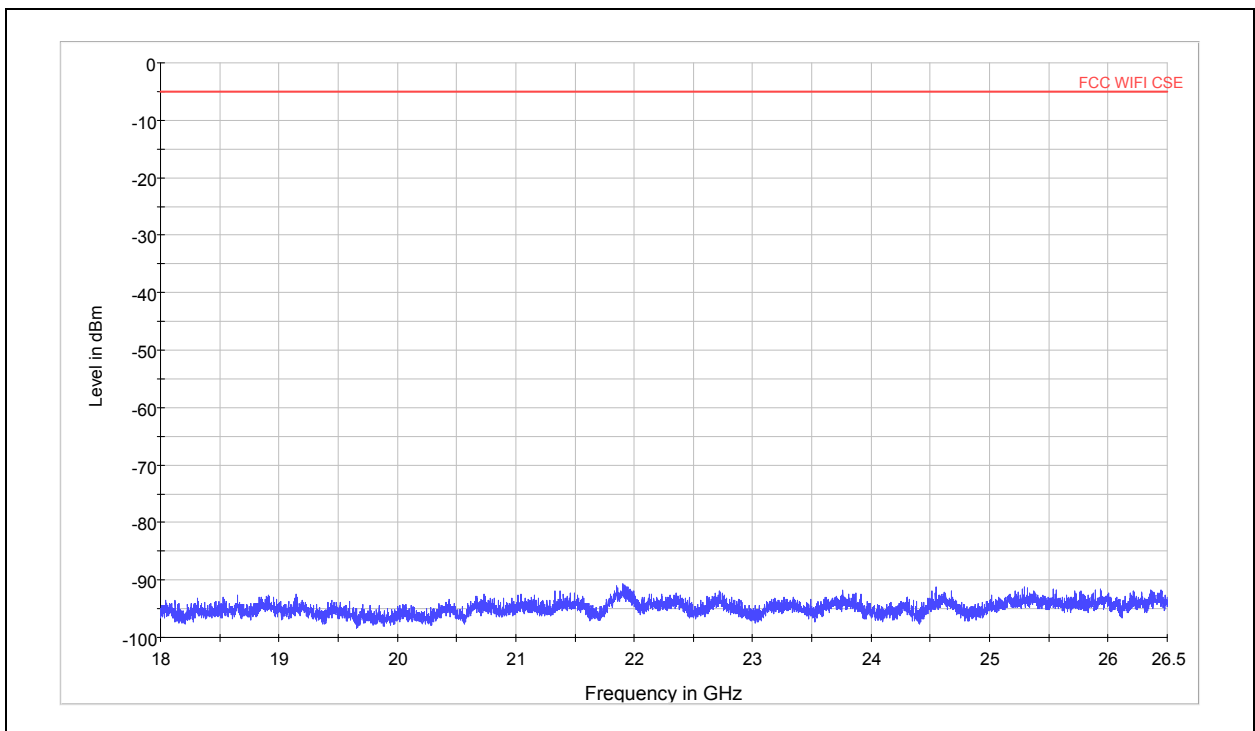

Spurious RF conducted emissions from 18GHz to 26.5GHz

# TA Technology (Shanghai) Co., Ltd. Test Report

Report No.: RZA1202-0233RF01R2

Page 54of 109

802.11n HT40 CH9

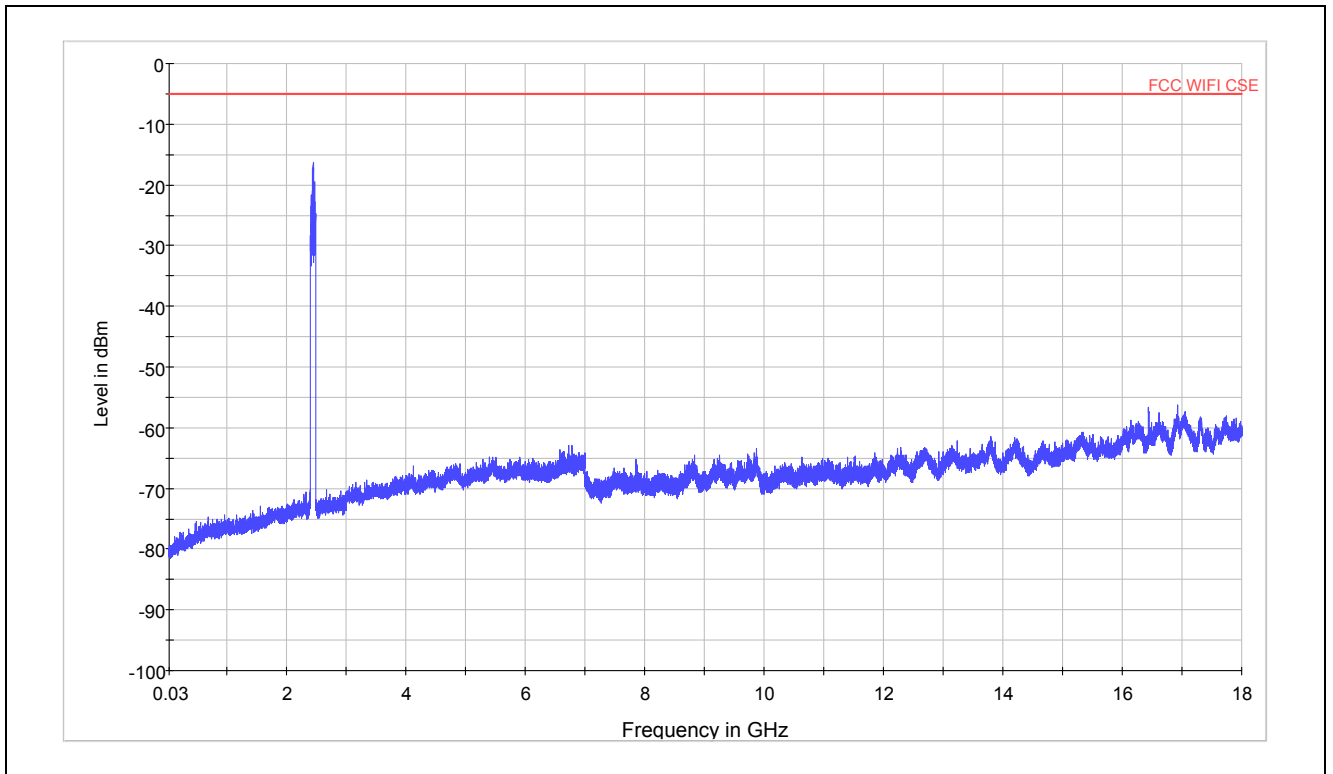

Note: The signal beyond the limit is carrier

Spurious RF conducted emissions from 30MHz to 18GHz

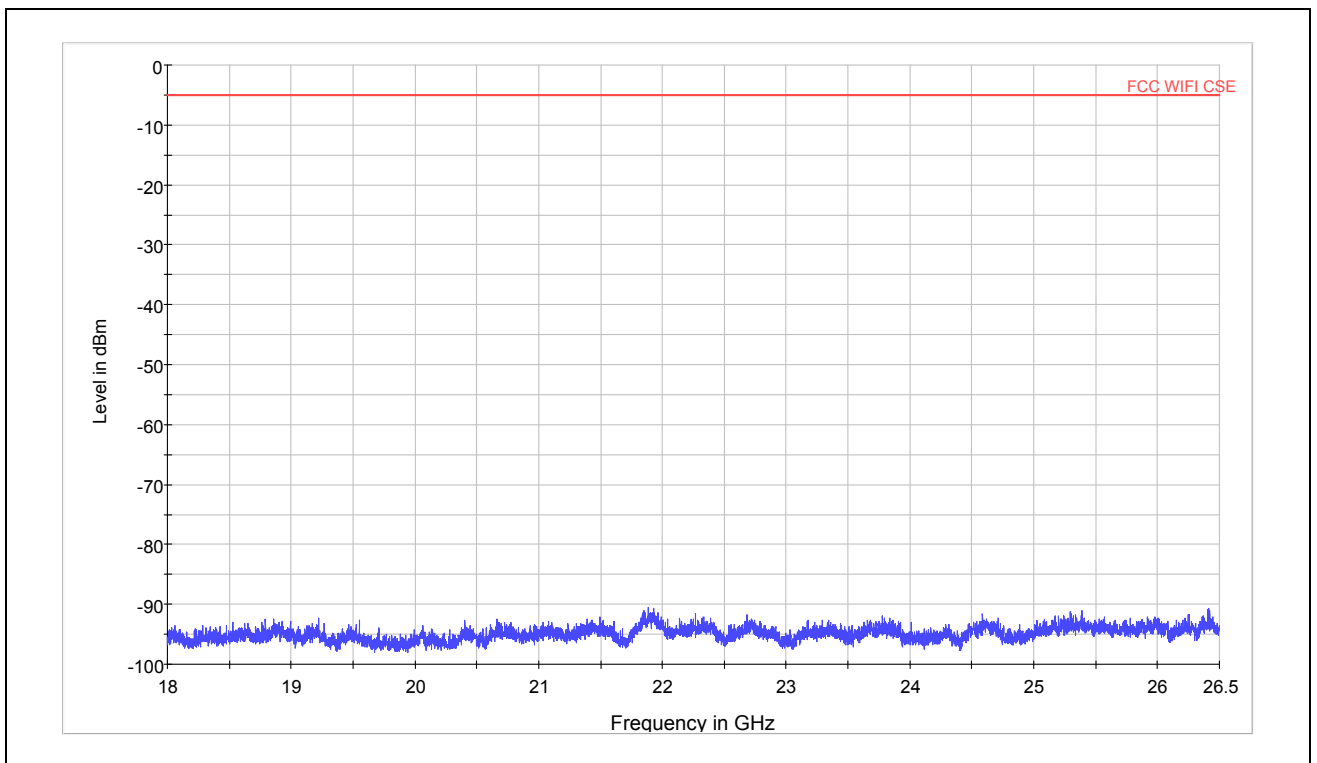

Spurious RF conducted emissions from 18GHz to 26.5GHz

## 2.8. Radiates Emission

### Ambient condition

Temperature	Relative humidity	Pressure
23°C ~25°C	45%~50%	101.5kPa

### Method of Measurement

The test set-up was made in accordance to the general provisions of ANSI C63.4-2009. The Equipment Under Test (EUT) was set up on a non-conductive table in the semi-anechoic chamber. The test was performed at the distance of 3 m between the EUT and the receiving antenna. The radiated emissions measurements were made in a typical installation configuration. Sweep the whole frequency band through the range from 30MHz to the 5th harmonic of the carrier. During the test, the height of receive antenna shall be moved from 1 to 4 meters, and the antenna shall be performed under horizontal and vertical polarization. The turntable shall be rotated from 0 to 360 degrees for detecting the maximum of radiated spurious signal level. The measurements shall be repeated with orthogonal polarization of the test antenna. The data of cable loss and antenna factor has been calibrated in full testing frequency range before the testing.

Set the spectrum analyzer in the following:

Below 1GHz (detector: Peak and Quasi-Peak)

RBW=100kHz / VBW=300kHz / Sweep=AUTO

Above 1GHz(detector: Peak):

(a) PEAK: RBW=1MHz VBW=3MHz/ Sweep=AUTO

(b) AVERAGE: RBW=1MHz / VBW=10Hz / Sweep=AUTO

The radiated emission was measured in the following position: EUT stand-up position (Z axis), lie-down position (X, Y axis). The worst emission was found in lie-down position (X axis) and the worst case was recorded.

The test is in transmitting mode.

Test setup

Below 1GHz

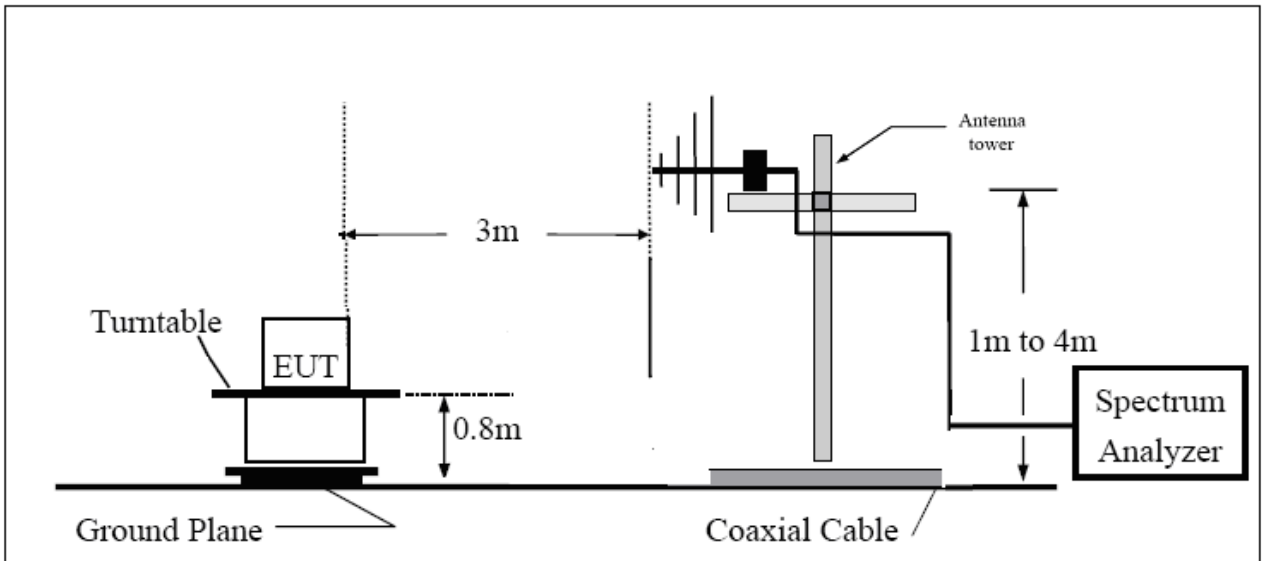

Above 1GHz

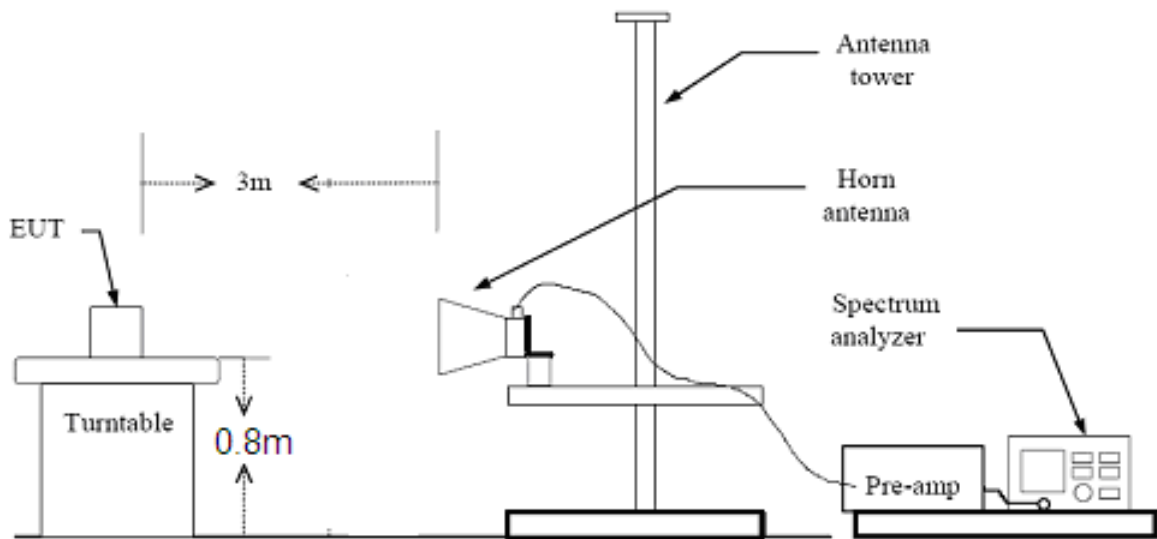



**TA Technology (Shanghai) Co., Ltd.**  
**Test Report**

Report No.: RZA1202-0233RF01R2

Page 57 of 109

**Limits**

Rule Part 15.247(d) specifies that “In addition, radiated emissions which fall in the restricted bands, as defined in § 15.205(a), must also comply with the radiated emission limits specified in § 15.209(a) (see § 15.205(c)).”

Limit in restricted band

Frequency of emission (MHz)	Field strength(uV/m)	Field strength(dBuV/m)
30-88	100	40
88-216	150	43.5
216-960	200	46
Above960	500	54

**Measurement Uncertainty**

The assessed measurement uncertainty to ensure 95% confidence level for the normal distribution is with the coverage factor  $k = 1.96$ .

Frequency	Uncertainty
30MHz-200MHz	4.19 dB
200MHz-1GHz	3.63 dB
1GHz – 6GHz	3.68 dB

# TA Technology (Shanghai) Co., Ltd. Test Report

**Test result**  
**802.11b CH1**

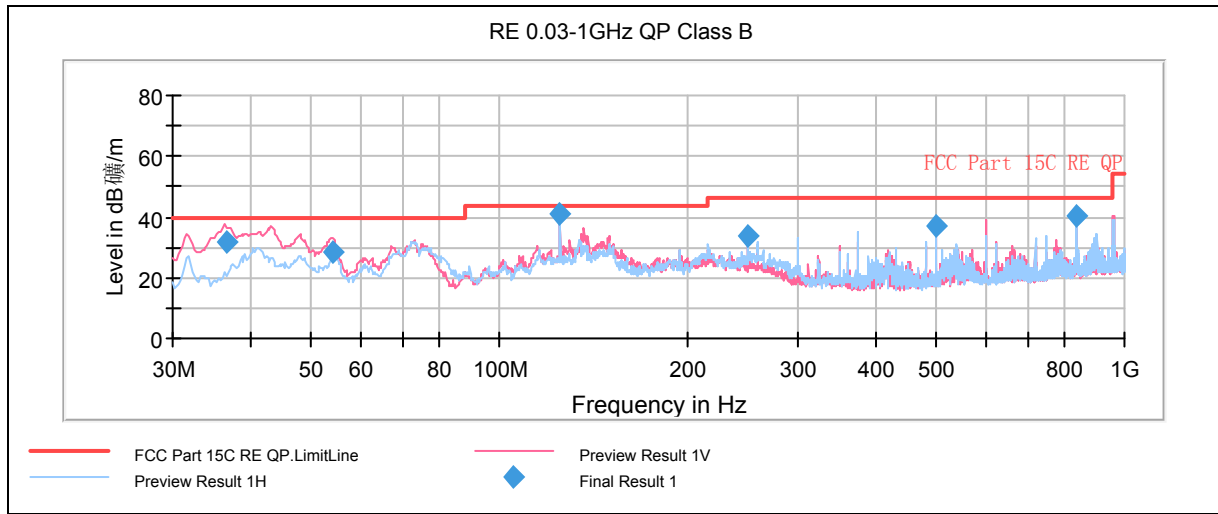

Radiates Emission from 30MHz to 1GHz

Frequency (MHz)	Quasi-Peak (dBuV/m)	Height (cm)	Polarization	Azimuth (deg)	Reading value (dBuV/m)	Correct Factor (dB)	Margin (dB)	Limit (dBuV/m)
36.545000	31.5	100.0	V	233.0	54.7	-23.2	8.5	40.0
54.047500	28.4	100.0	V	75.0	53.3	-24.9	11.6	40.0
124.980000	40.7	175.0	H	57.0	70.8	-30.1	2.8	43.5
249.987500	33.4	100.0	H	46.0	60.3	-26.9	12.6	46.0
500.005000	37.3	100.0	H	132.0	58.9	-21.6	8.7	46.0
839.992500	40.2	121.0	H	68.0	56.8	-16.6	5.8	46.0

- Remark: 1. Quasi-Peak = Reading value + Correction factor**  
**2. Correction Factor = Antenna factor+ Insertion loss(cable loss+amplifier gain)**  
**3. Margin = Limit – Quasi-Peak**

# TA Technology (Shanghai) Co., Ltd. Test Report

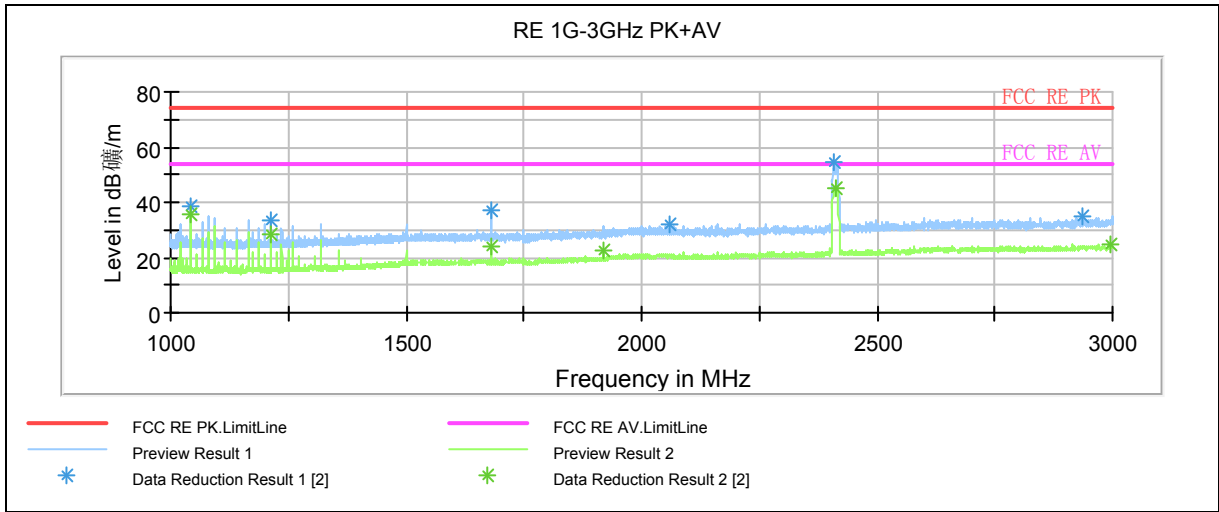

Note: The signal beyond the limit is carrier.  
Radiates Emission from 1GHz to 3GHz

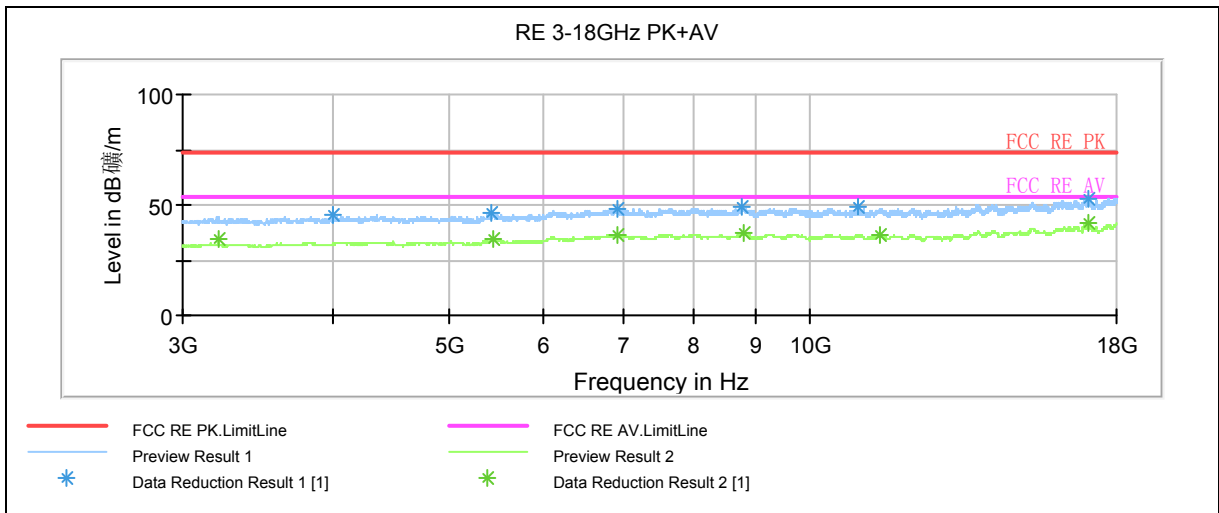

Radiates Emission from 3GHz to 18GHz

# TA Technology (Shanghai) Co., Ltd. Test Report

## 802.11b CH6

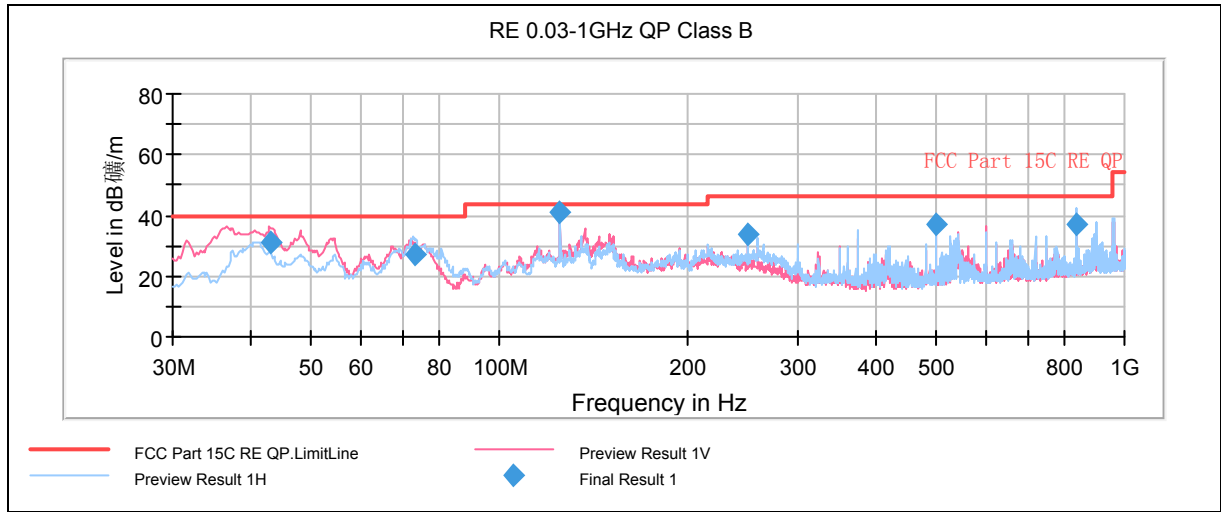

Radiates Emission from 30MHz to 1GHz

Frequency (MHz)	Quasi-Peak (dBuV/m)	Height (cm)	Polarization	Azimuth (deg)	Reading value (dBuV/m)	Correct Factor (dB)	Margin (dB)	Limit (dBuV/m)
43.132500	31.3	100.0	V	284.0	54.6	-23.3	8.7	40.0
73.442500	26.9	221.0	H	20.0	57.1	-30.2	13.1	40.0
125.020000	41.0	175.0	H	64.0	71.1	-30.1	2.5	43.5
249.987500	33.6	100.0	H	25.0	60.5	-26.9	12.4	46.0
500.005000	37.1	100.0	H	134.0	58.7	-21.6	8.9	46.0
839.992500	37.2	125.0	H	78.0	53.8	-16.6	8.8	46.0

**Remark: 1. Quasi-Peak = Reading value + Correction factor**

**2. Correction Factor = Antenna factor+ Insertion loss(cable loss+amplifier gain)**

**3. Margin = Limit – Quasi-Peak**

# TA Technology (Shanghai) Co., Ltd. Test Report

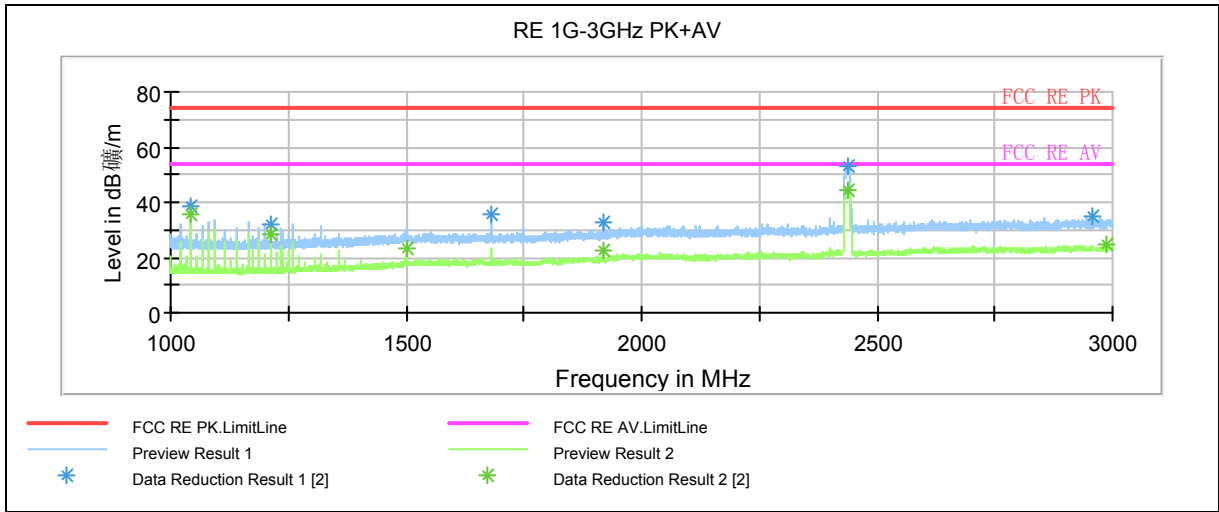

Note: The signal beyond the limit is carrier.  
Radiates Emission from 1GHz to 3GHz

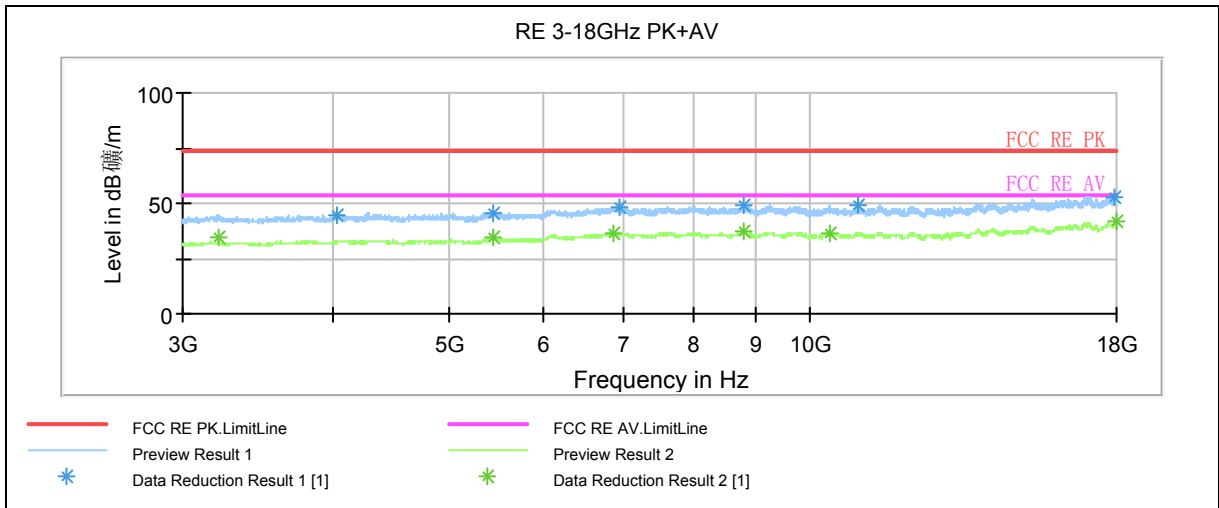

Radiates Emission from 3GHz to 18GHz

# TA Technology (Shanghai) Co., Ltd. Test Report

## 802.11b CH11

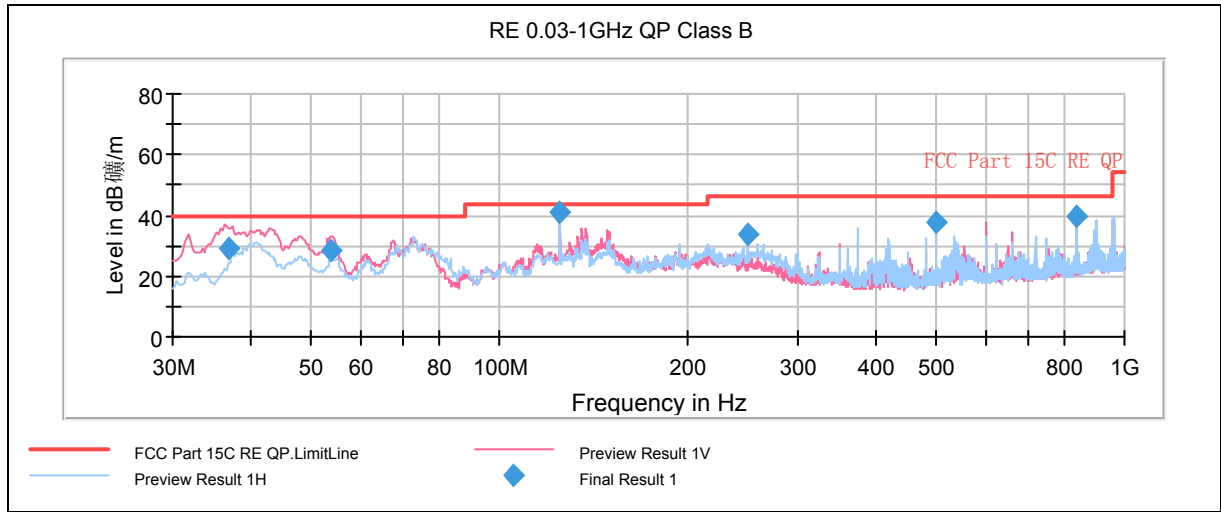

Radiates Emission from 30MHz to 1GHz

Frequency (MHz)	Quasi-Peak (dBuV/m)	Height (cm)	Polarization	Azimuth (deg)	Reading value (dBuV/m)	Correct Factor (dB)	Margin (dB)	Limit (dBuV/m)
36.865000	29.1	121.0	V	180.0	52.2	-23.1	10.9	40.0
53.850000	28.7	100.0	V	77.0	53.5	-24.8	11.3	40.0
125.020000	40.9	175.0	H	66.0	71	-30.1	2.6	43.5
249.987500	33.7	100.0	H	68.0	60.6	-26.9	12.3	46.0
500.005000	37.8	100.0	H	125.0	59.4	-21.6	8.2	46.0
839.992500	39.9	121.0	H	66.0	56.5	-16.6	6.1	46.0

**Remark: 1. Quasi-Peak = Reading value + Correction factor**

**2. Correction Factor = Antenna factor+ Insertion loss(cable loss+amplifier gain)**

**3. Margin = Limit – Quasi-Peak**

# TA Technology (Shanghai) Co., Ltd. Test Report

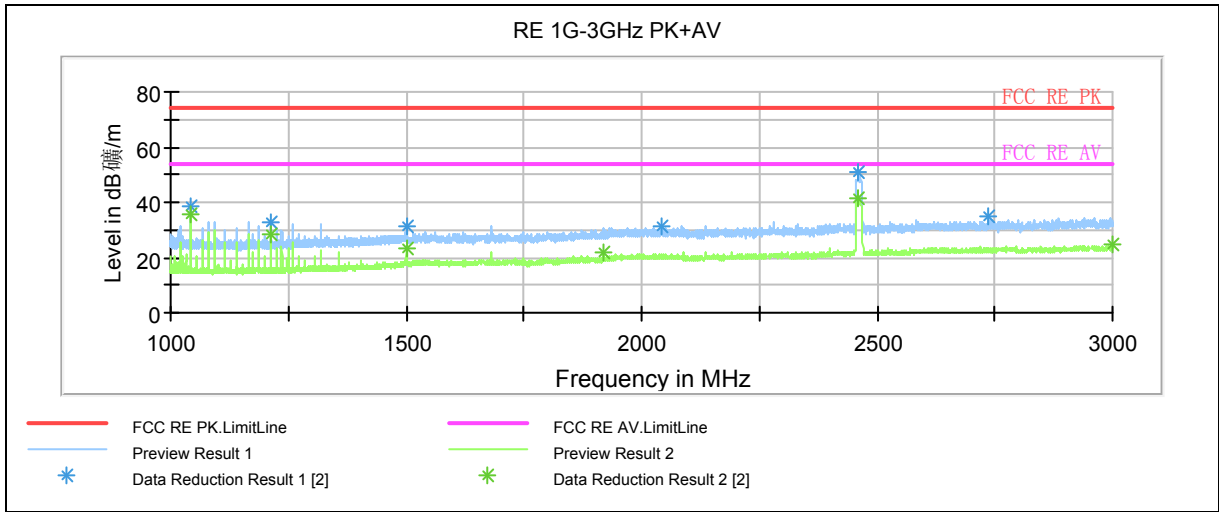

Note: The signal beyond the limit is carrier.  
Radiates Emission from 1GHz to 3GHz

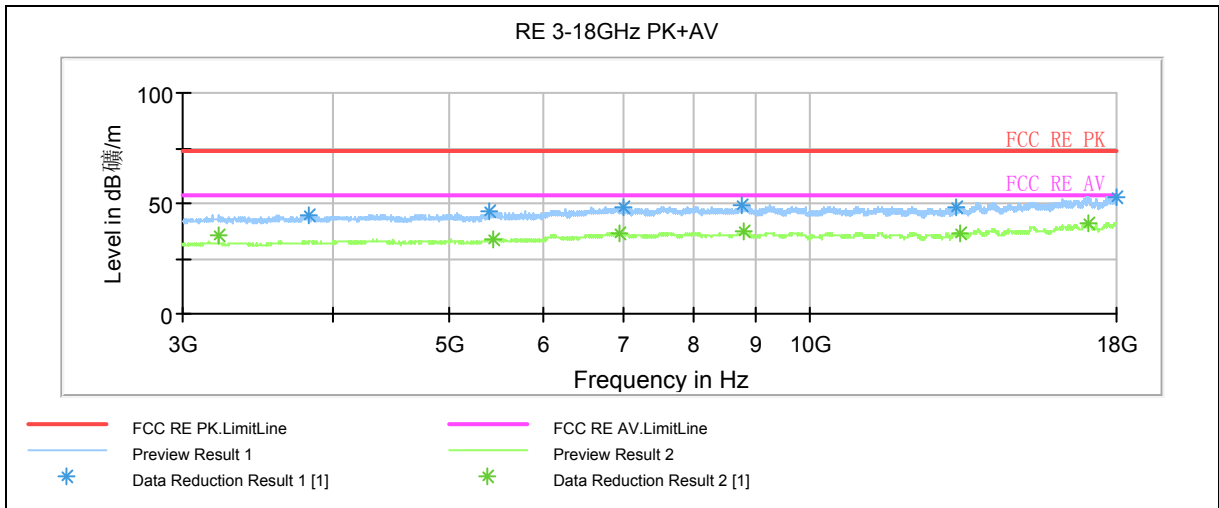

Radiates Emission from 3GHz to 18GHz

# TA Technology (Shanghai) Co., Ltd. Test Report

## 802.11g CH1

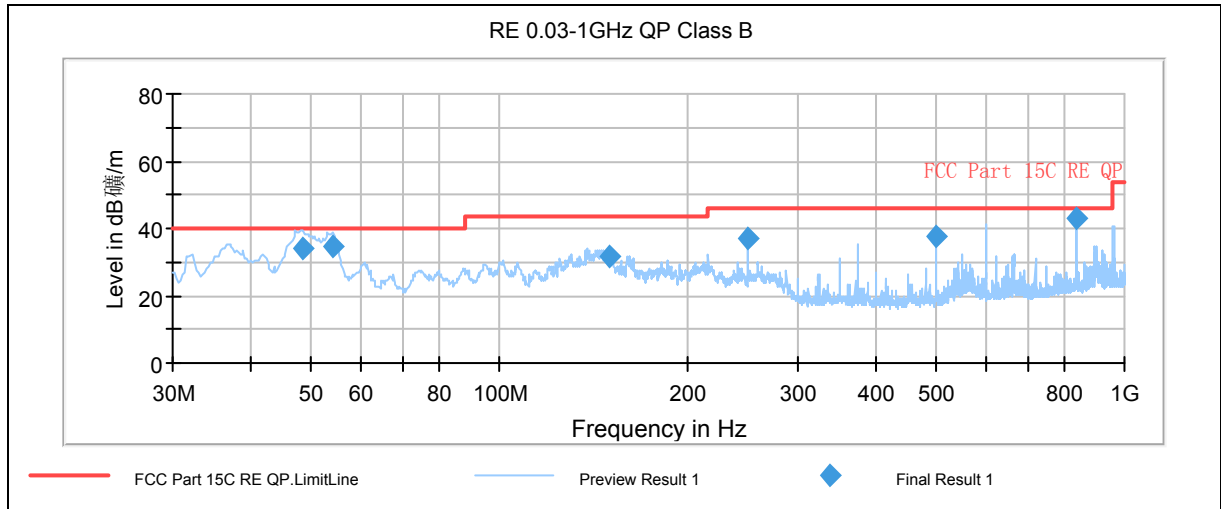

Radiates Emission from 30MHz to 1GHz

Frequency (MHz)	Quasi-Peak (dBuV/m)	Height (cm)	Polarization	Azimuth (deg)	Reading value (dBuV/m)	Correct Factor (dB)	Margin (dB)	Limit (dBuV/m)
48.587500	34.1	100.0	V	119.0	58.2	-24.1	5.9	40.0
53.967500	34.5	100.0	V	122.0	59.3	-24.8	5.5	40.0
149.995000	31.8	100.0	V	132.0	63.1	-31.3	11.7	43.5
249.987500	37.0	121.0	H	0.0	63.9	-26.9	9.0	46.0
500.005000	37.5	175.0	H	6.0	59.1	-21.6	8.5	46.0
839.992500	42.7	100.0	H	8.0	59.3	-16.6	3.3	46.0

**Remark: 1. Quasi-Peak = Reading value + Correction factor**

**2. Correction Factor = Antenna factor+ Insertion loss(cable loss+amplifier gain)**

**3. Margin = Limit – Quasi-Peak**



# TA Technology (Shanghai) Co., Ltd. Test Report

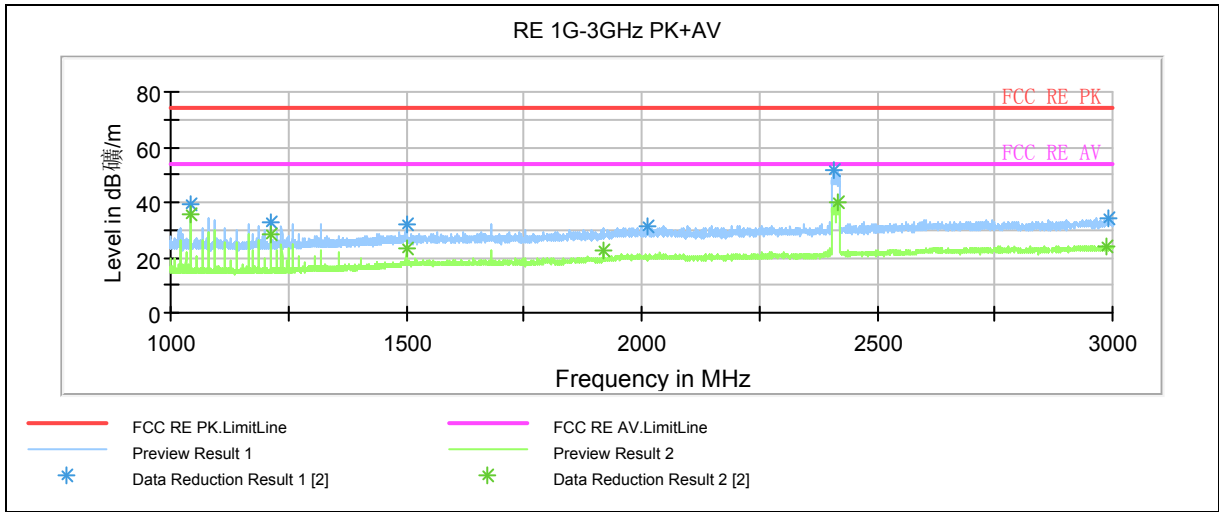

Note: The signal beyond the limit is carrier.  
Radiates Emission from 1GHz to 3GHz

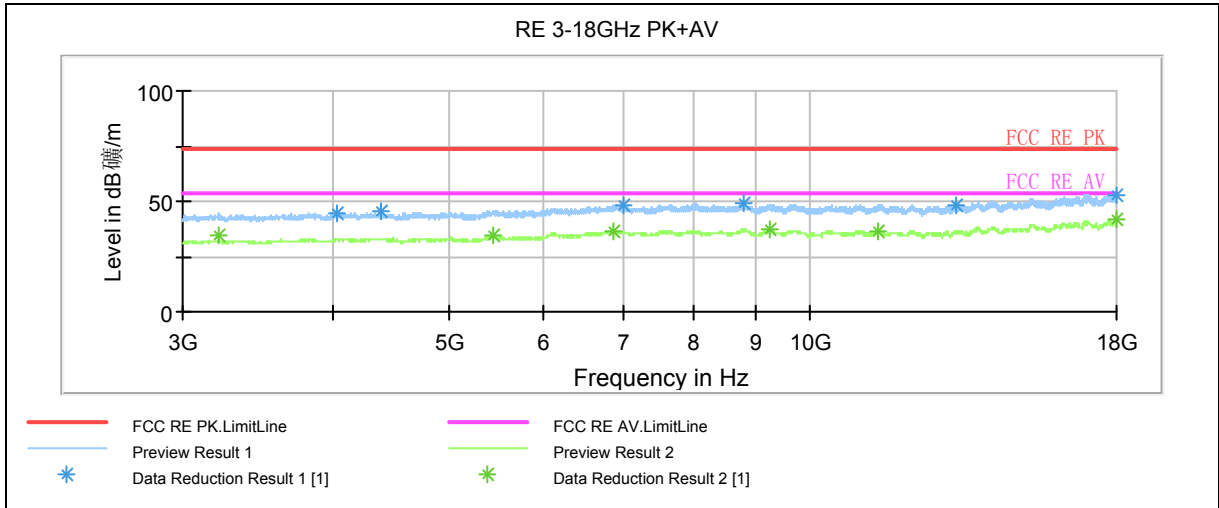

Radiates Emission from 3GHz to 18GHz

# TA Technology (Shanghai) Co., Ltd. Test Report

## 802.11g CH6

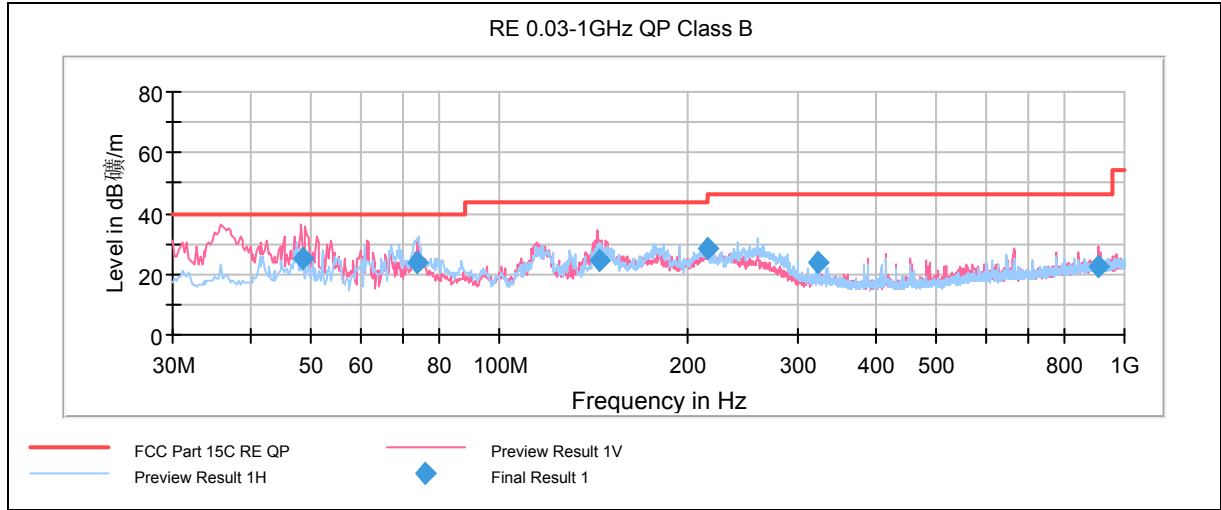

Radiates Emission from 30MHz to 1GHz

Frequency (MHz)	Quasi-Peak (dBuV/m)	Height (cm)	Polarization	Azimuth (deg)	Reading value (dBuV/m)	Correct Factor (dB)	Margin (dB)	Limit (dBuV/m)
48.467500	25.2	100.0	V	316.0	49.2	-24.0	14.8	40.0
73.937500	23.9	200.0	H	16.0	54.1	-30.2	16.1	40.0
144.252500	24.4	100.0	V	45.0	55.8	-31.4	19.1	43.5
215.997500	28.3	209.0	V	24.0	56.6	-28.3	15.2	43.5
323.465000	23.7	175.0	V	52.0	49.1	-25.4	22.3	46.0
906.602500	22.6	100.0	V	32.0	38.2	-15.6	23.4	46.0

**Remark: 1. Quasi-Peak = Reading value + Correction factor**

**2. Correction Factor = Antenna factor+ Insertion loss(cable loss+amplifier gain)**

**3. Margin = Limit – Quasi-Peak**

# TA Technology (Shanghai) Co., Ltd. Test Report

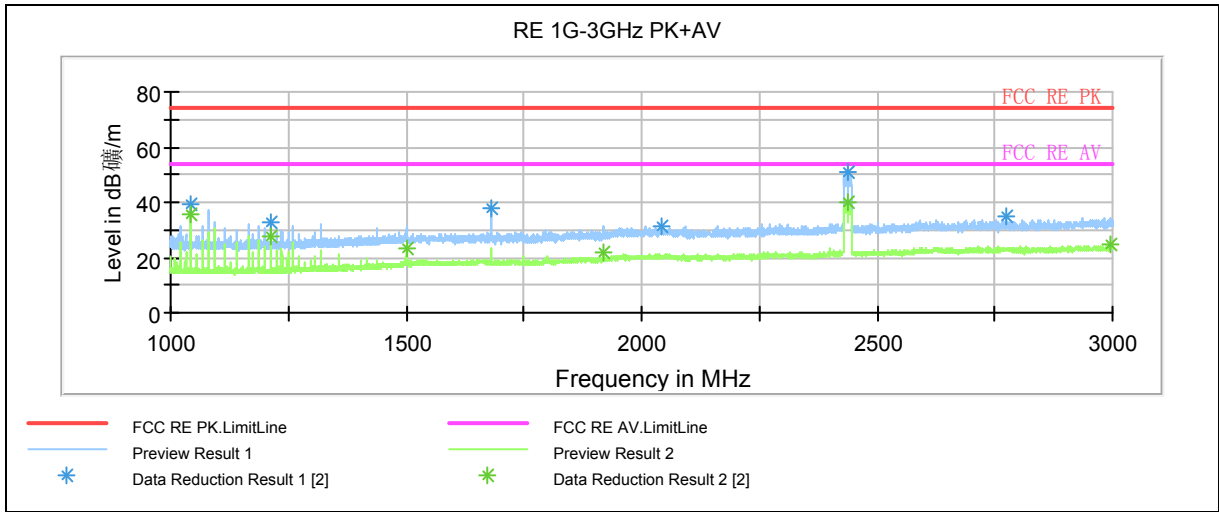

Note: The signal beyond the limit is carrier.  
Radiates Emission from 1GHz to 3GHz

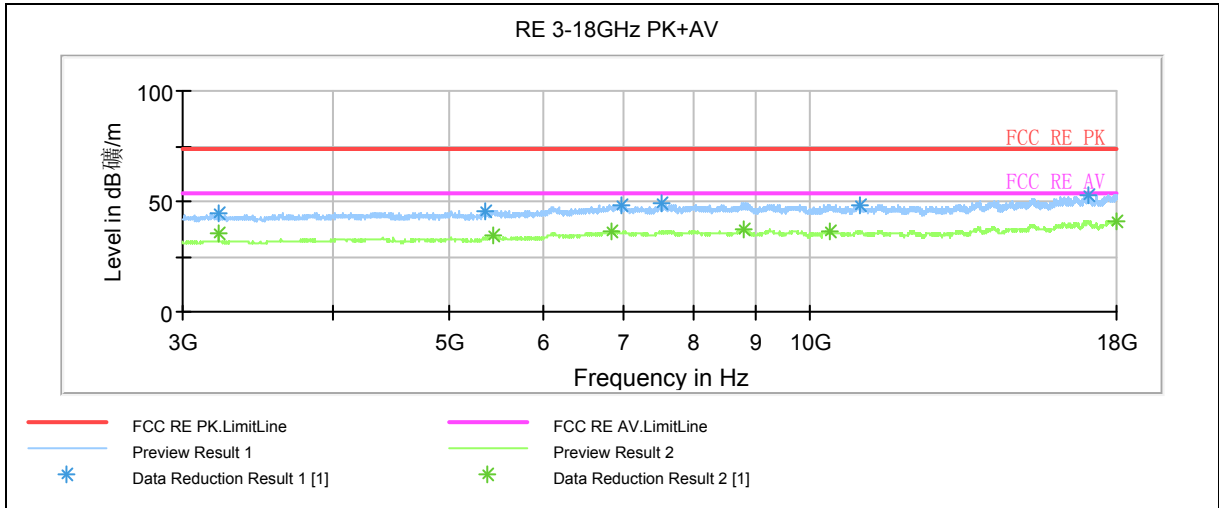

Radiates Emission from 3GHz to 18GHz

# TA Technology (Shanghai) Co., Ltd. Test Report

## 802.11g CH11

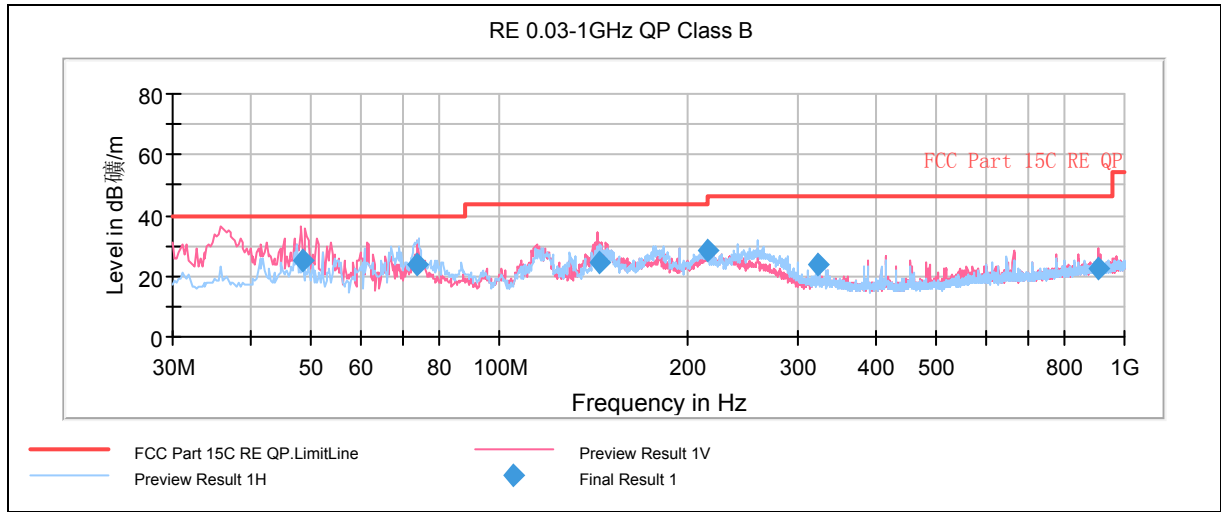

Radiates Emission from 30MHz to 1GHz

Frequency (MHz)	Quasi-Peak (dBuV/m)	Height (cm)	Polarization	Azimuth (deg)	Reading value (dBuV/m)	Correct Factor (dB)	Margin (dB)	Limit (dBuV/m)
48.467500	25.2	100.0	V	316.0	49.2	-24.0	14.8	40.0
73.937500	23.9	200.0	H	16.0	54.1	-30.2	16.1	40.0
144.252500	24.4	100.0	V	45.0	55.8	-31.4	19.1	43.5
215.997500	28.3	209.0	V	24.0	56.6	-28.3	15.2	43.5
323.465000	23.7	175.0	V	52.0	49.1	-25.4	22.3	46.0
906.602500	22.6	100.0	V	32.0	38.2	-15.6	23.4	46.0

**Remark: 1. Quasi-Peak = Reading value + Correction factor**

**2. Correction Factor = Antenna factor+ Insertion loss(cable loss+amplifier gain)**

**3. Margin = Limit – Quasi-Peak**

# TA Technology (Shanghai) Co., Ltd. Test Report

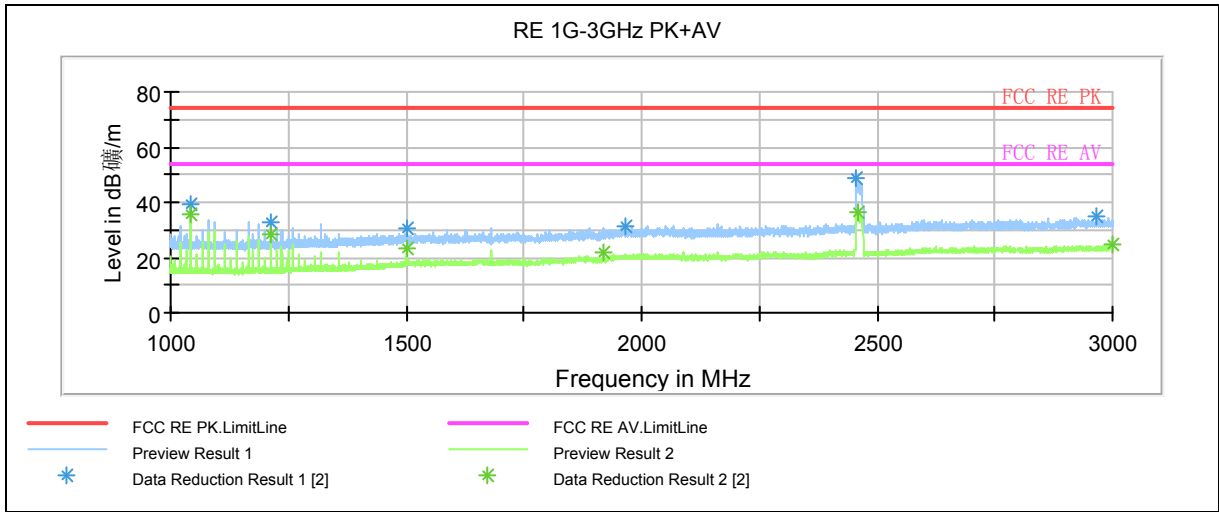

Note: The signal beyond the limit is carrier.  
Radiates Emission from 1GHz to 3GHz

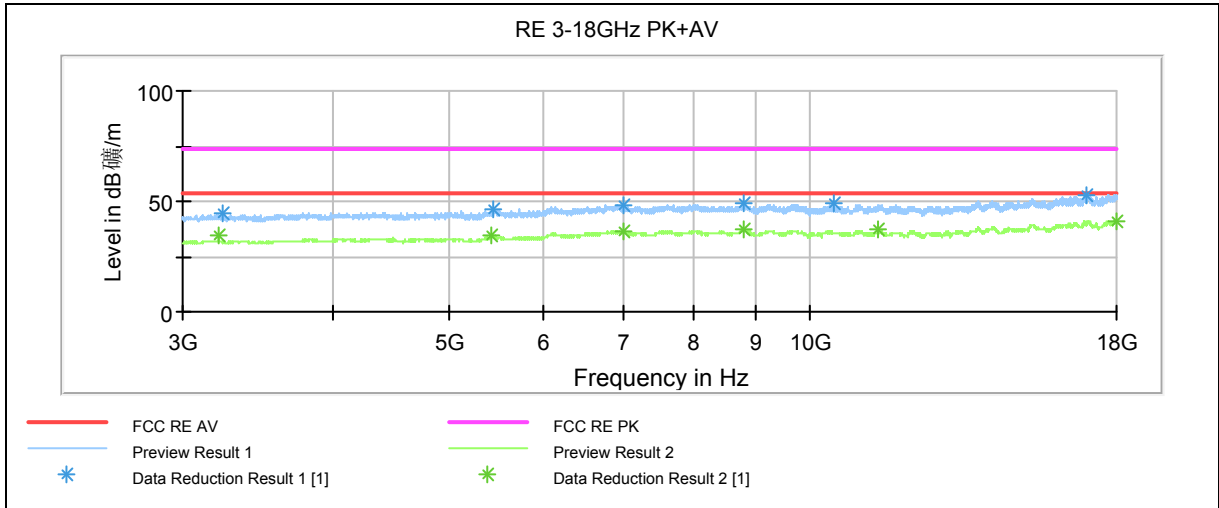

Radiates Emission from 3GHz to 18GHz

# TA Technology (Shanghai) Co., Ltd. Test Report

## 802.11n HT20 CH1

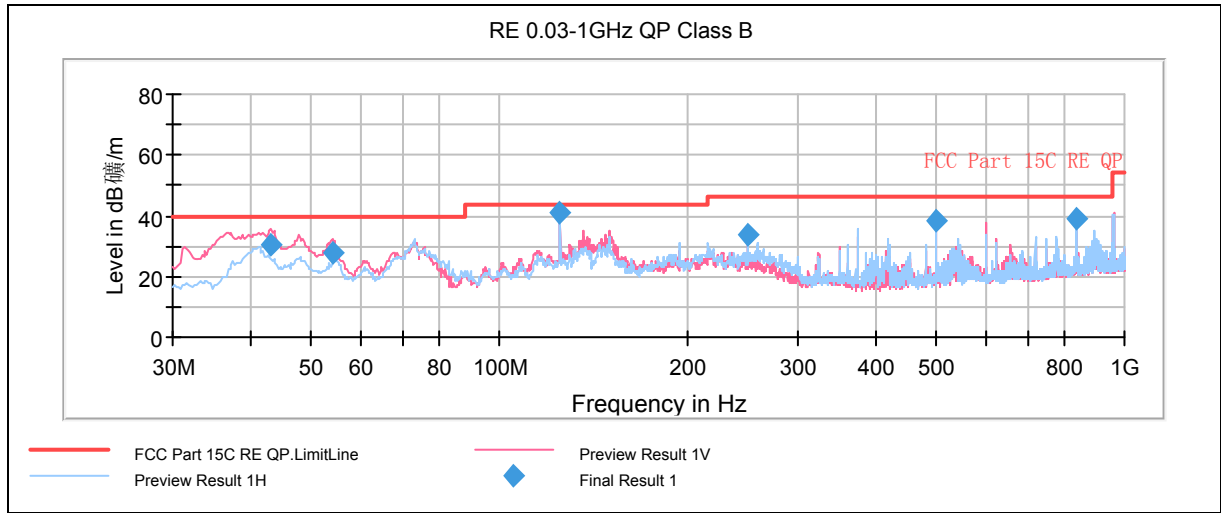

Radiates Emission from 30MHz to 1GHz

Frequency (MHz)	Quasi-Peak (dBuV/m)	Height (cm)	Polarization	Azimuth (deg)	Reading value (dBuV/m)	Correct Factor (dB)	Margin (dB)	Limit (dBuV/m)
43.135000	30.7	100.0	V	307.0	54	-23.3	9.3	40.0
54.167500	28.0	100.0	V	78.0	52.9	-24.9	12.0	40.0
125.020000	41.1	175.0	H	65.0	71.2	-30.1	2.4	43.5
249.987500	33.7	100.0	H	40.0	60.6	-26.9	12.3	46.0
500.005000	38.5	100.0	H	126.0	60.1	-21.6	7.5	46.0
839.992500	39.2	121.0	H	75.0	55.8	-16.6	6.8	46.0

**Remark: 1. Quasi-Peak = Reading value + Correction factor**

**2. Correction Factor = Antenna factor+ Insertion loss(cable loss+amplifier gain)**

**3. Margin = Limit – Quasi-Peak**

# TA Technology (Shanghai) Co., Ltd. Test Report

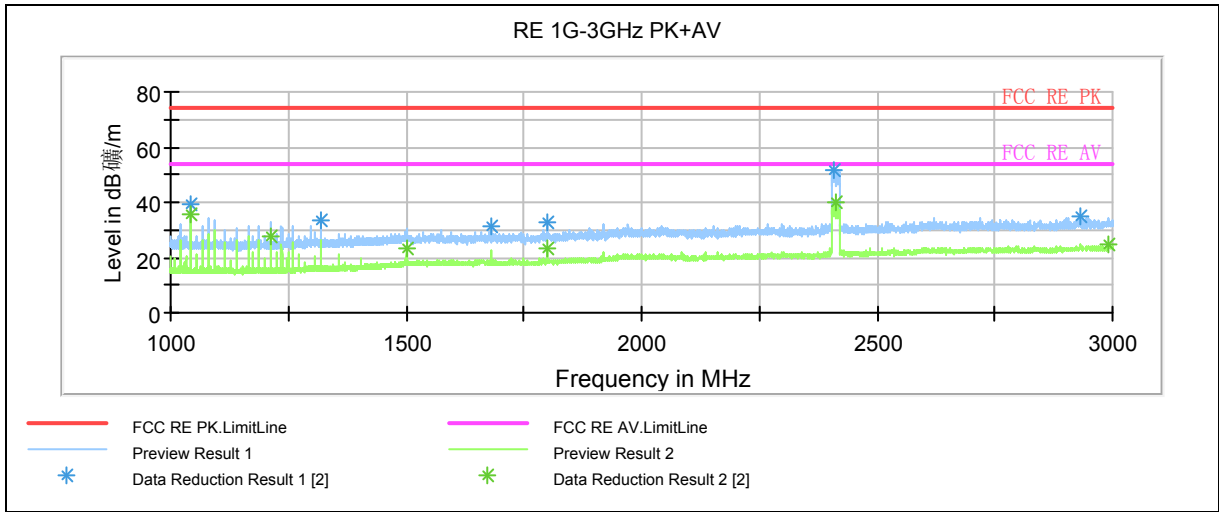

Note: The signal beyond the limit is carrier.  
Radiates Emission from 1GHz to 3GHz

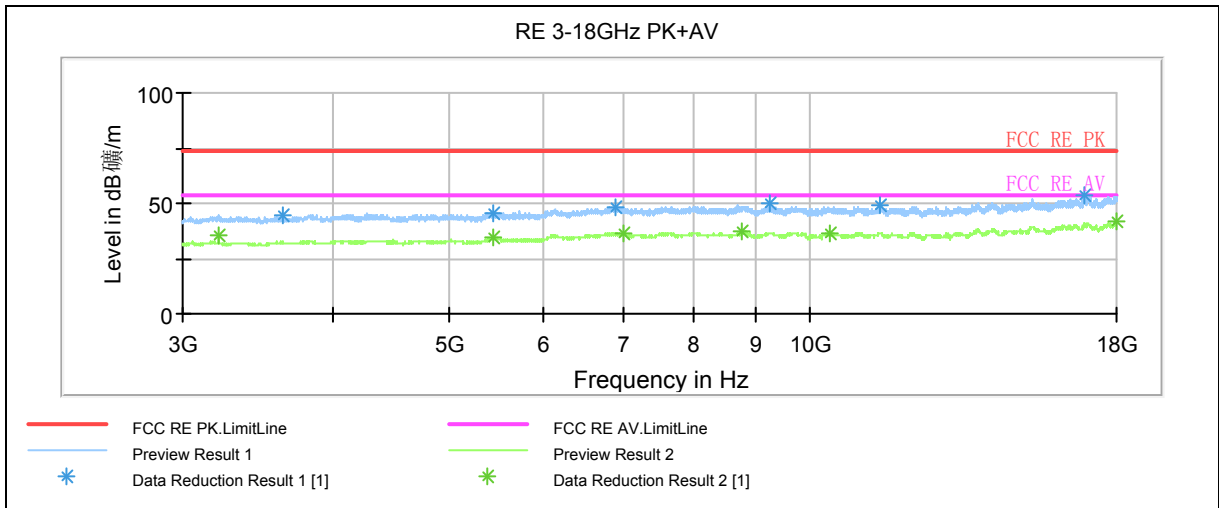

Radiates Emission from 3GHz to 18GHz

# TA Technology (Shanghai) Co., Ltd. Test Report

## 802.11n HT20 CH6

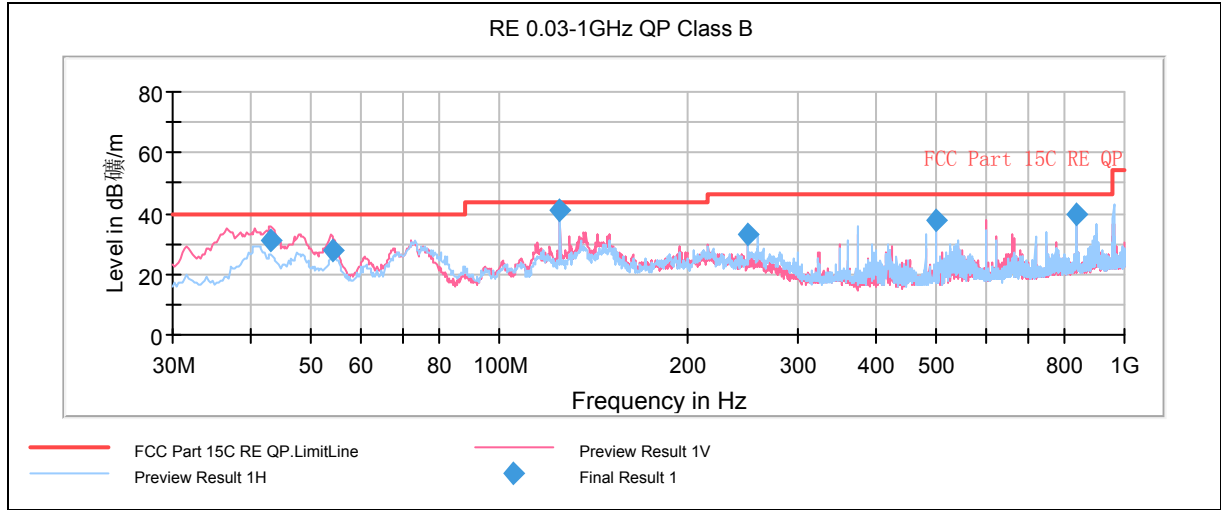

Radiates Emission from 30MHz to 1GHz

Frequency (MHz)	Quasi-Peak (dBuV/m)	Height (cm)	Polarization	Azimuth (deg)	Reading value (dBuV/m)	Correct Factor (dB)	Margin (dB)	Limit (dBuV/m)
43.175000	30.8	100.0	V	307.0	54.1	-23.3	9.2	40.0
54.087500	27.8	100.0	V	83.0	52.7	-24.9	12.2	40.0
125.020000	41.1	175.0	H	64.0	71.2	-30.1	2.4	43.5
249.987500	33.2	100.0	H	66.0	60.1	-26.9	12.8	46.0
500.005000	37.7	100.0	H	131.0	59.3	-21.6	8.3	46.0
839.992500	39.9	121.0	H	72.0	56.5	-16.6	6.1	46.0

**Remark: 1. Quasi-Peak = Reading value + Correction factor**

**2. Correction Factor = Antenna factor+ Insertion loss(cable loss+amplifier gain)**

**3. Margin = Limit – Quasi-Peak**



# TA Technology (Shanghai) Co., Ltd. Test Report

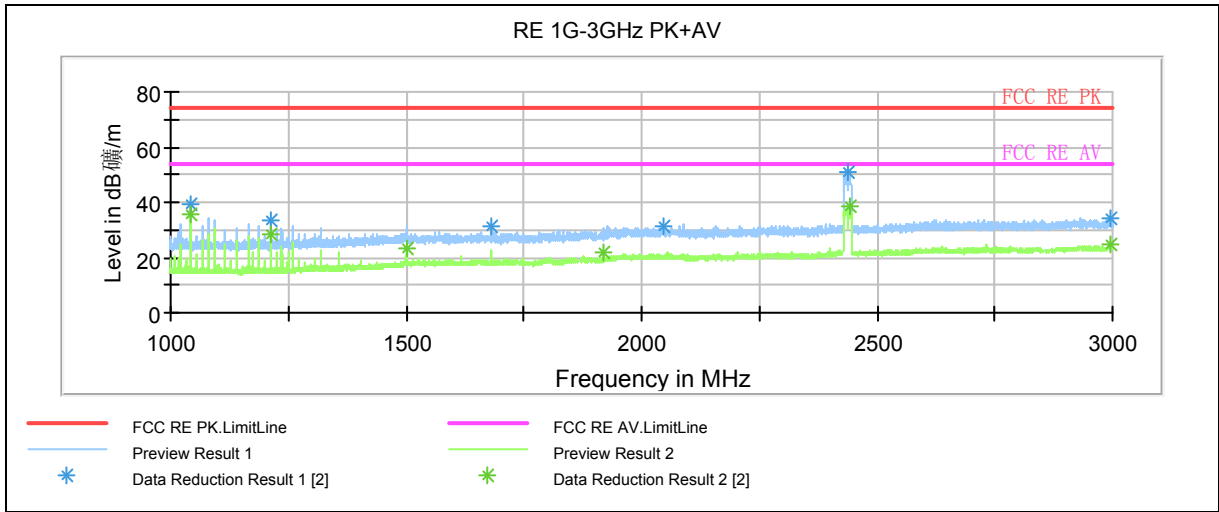

Note: The signal beyond the limit is carrier.  
Radiates Emission from 1GHz to 3GHz

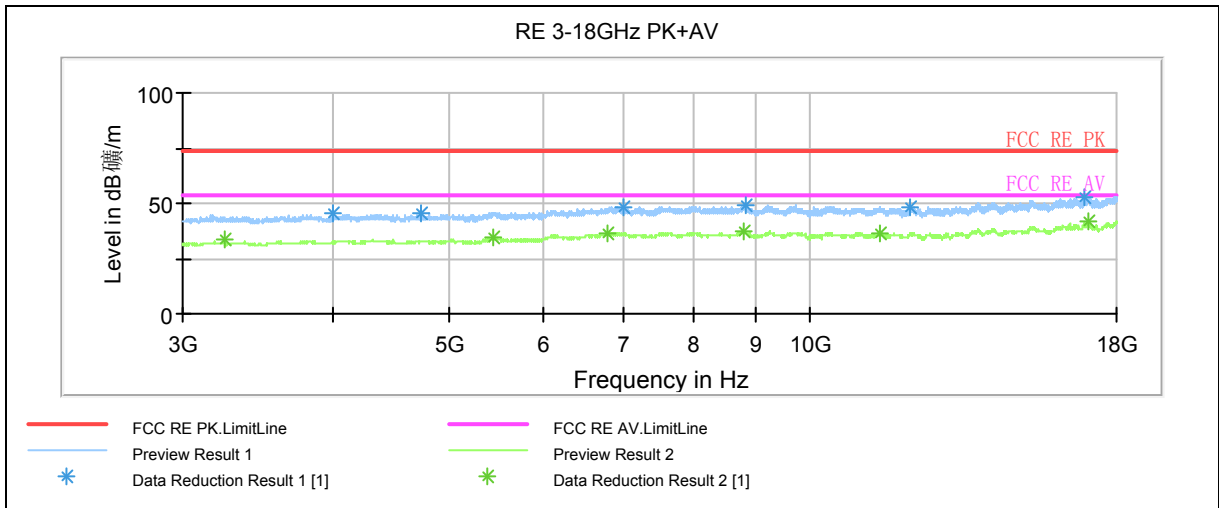

Radiates Emission from 3GHz to 18GHz

# TA Technology (Shanghai) Co., Ltd. Test Report

## 802.11n HT20 CH11

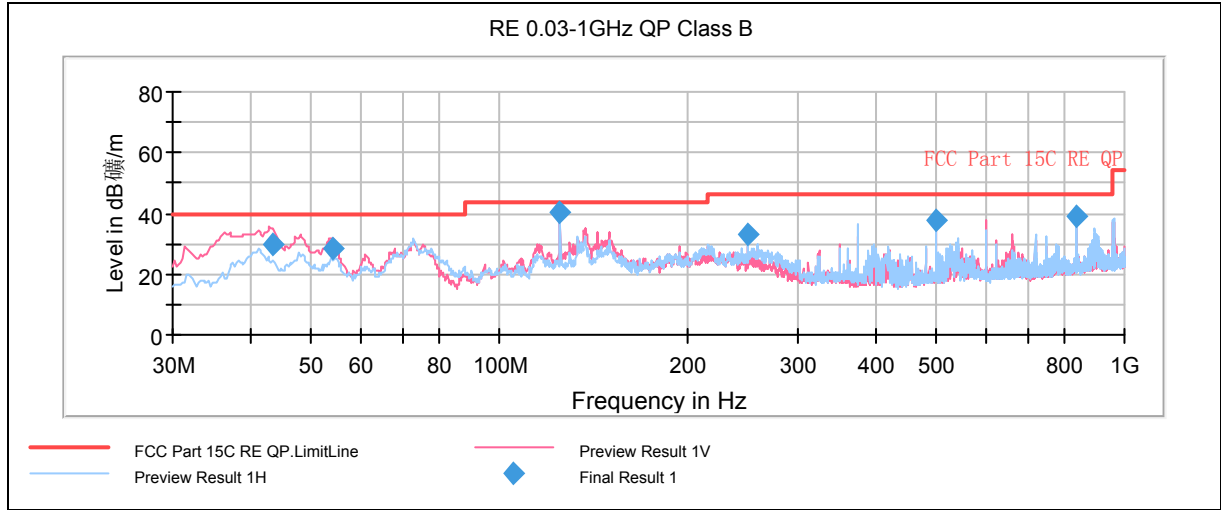

Radiates Emission from 30MHz to 1GHz

Frequency (MHz)	Quasi-Peak (dB $\mu$ V/m)	Height (cm)	Polarization	Azimuth (deg)	Reading value (dB $\mu$ V/m)	Correct Factor (dB)	Margin (dB)	Limit (dB $\mu$ V/m)
43.452500	30.0	100.0	V	300.0	53.4	-23.4	10.0	40.0
54.167500	28.2	100.0	V	75.0	53.1	-24.9	11.8	40.0
125.020000	40.6	196.0	H	70.0	70.7	-30.1	2.9	43.5
249.987500	33.3	100.0	H	67.0	60.2	-26.9	12.7	46.0
500.005000	37.6	120.0	V	57.0	59.2	-21.6	8.4	46.0
839.992500	38.9	125.0	H	67.0	55.5	-16.6	7.1	46.0

**Remark: 1. Quasi-Peak = Reading value + Correction factor**

**2. Correction Factor = Antenna factor+ Insertion loss(cable loss+amplifier gain)**

**3. Margin = Limit – Quasi-Peak**

# TA Technology (Shanghai) Co., Ltd. Test Report

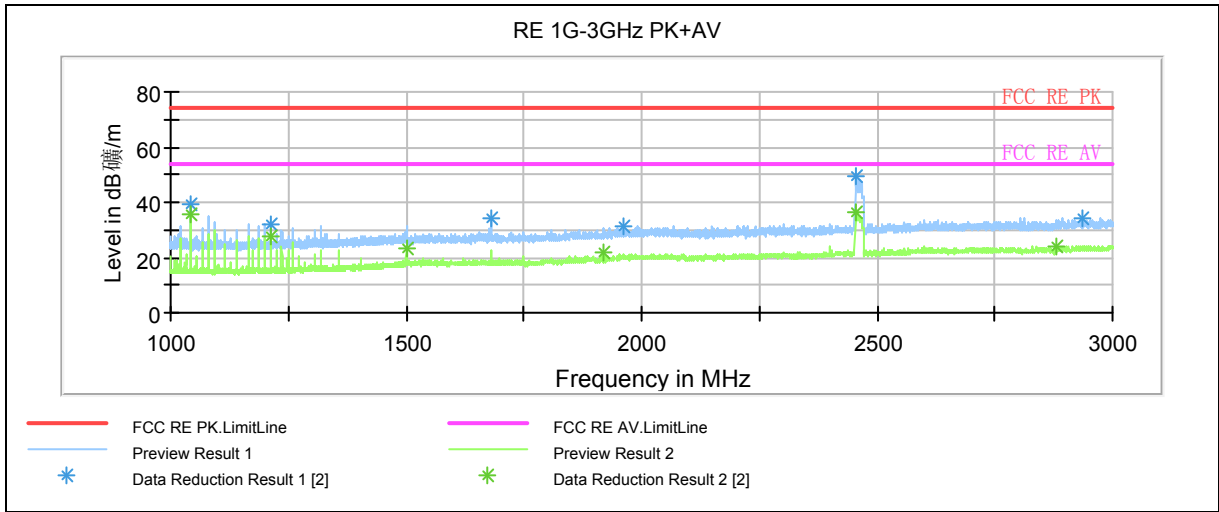

Note: The signal beyond the limit is carrier.  
Radiates Emission from 1GHz to 3GHz

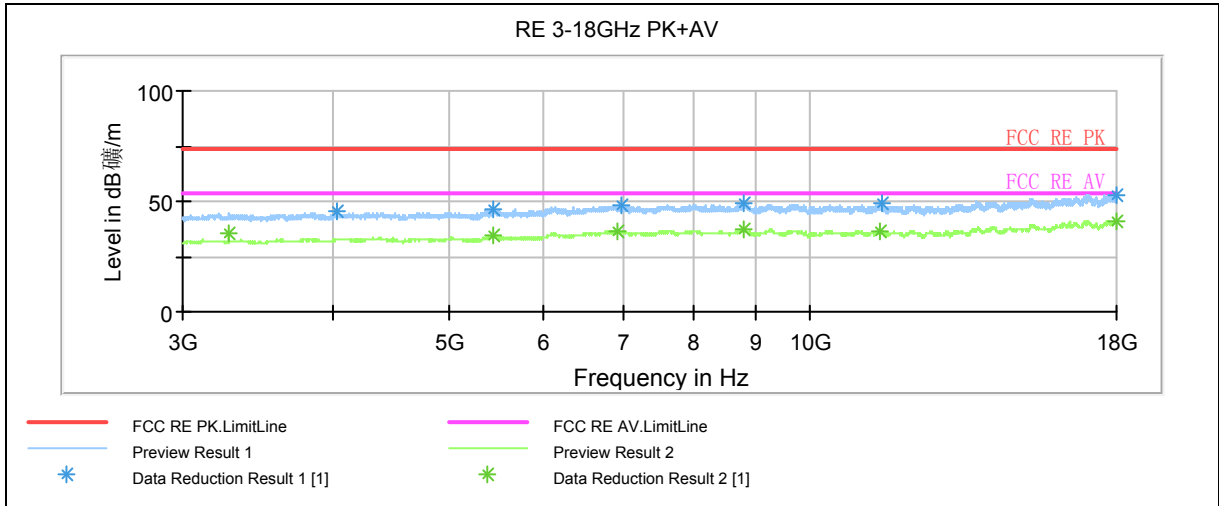

Radiates Emission from 3GHz to 18GHz

# TA Technology (Shanghai) Co., Ltd. Test Report

## 802.11n HT40 CH3

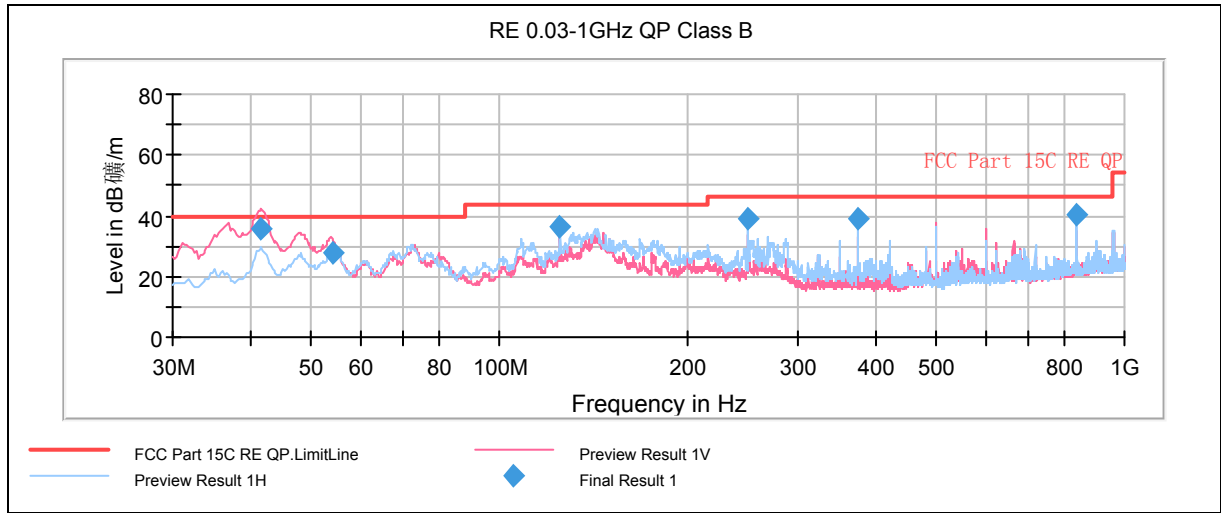

Radiates Emission from 30MHz to 1GHz

Frequency (MHz)	Quasi-Peak (dBuV/m)	Height (cm)	Polarization	Azimuth (deg)	Reading value (dBuV/m)	Correct Factor (dB)	Margin (dB)	Limit (dBuV/m)
41.520000	35.8	100.0	V	188.0	58.8	-23.0	4.2	40.0
53.967500	27.9	100.0	V	304.0	52.7	-24.8	12.1	40.0
124.980000	36.6	175.0	H	301.0	66.7	-30.1	6.9	43.5
249.987500	39.1	120.0	H	220.0	66	-26.9	6.9	46.0
374.997500	38.8	100.0	H	278.0	63	-24.2	7.2	46.0
839.992500	40.3	100.0	H	29.0	56.9	-16.6	5.7	46.0

**Remark: 1. Quasi-Peak = Reading value + Correction factor**

**2. Correction Factor = Antenna factor+ Insertion loss(cable loss+amplifier gain)**

**3. Margin = Limit – Quasi-Peak**

# TA Technology (Shanghai) Co., Ltd. Test Report

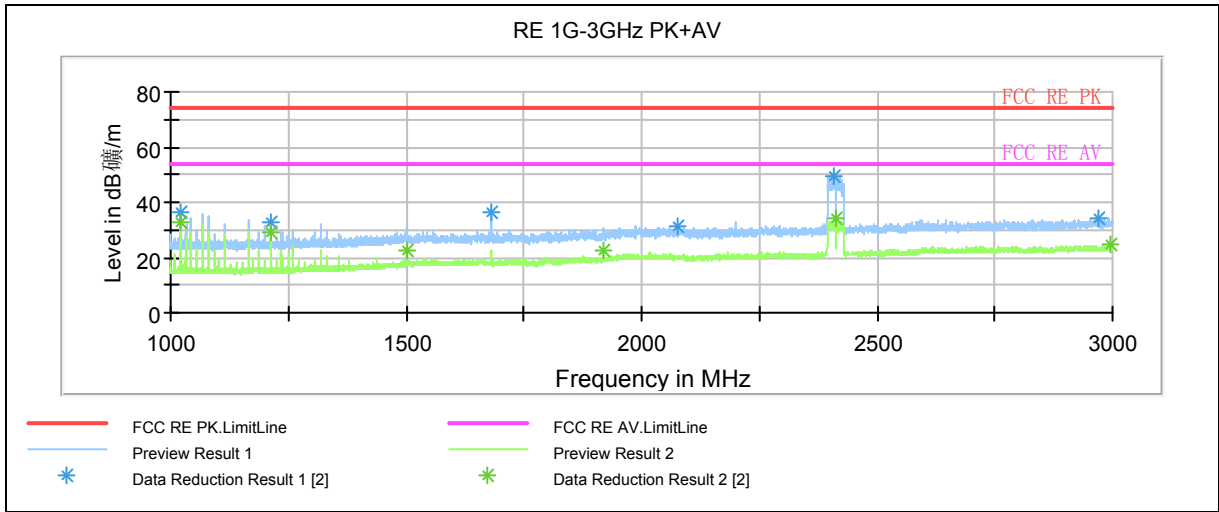

Note: The signal beyond the limit is carrier.  
Radiates Emission from 1GHz to 3GHz

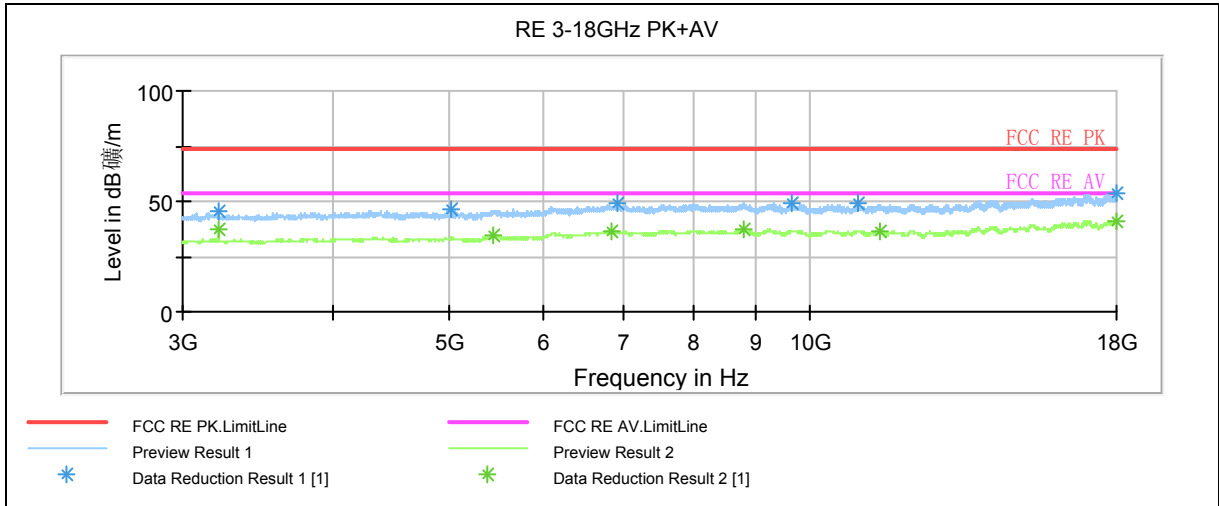

Radiates Emission from 3GHz to 18GHz

# TA Technology (Shanghai) Co., Ltd. Test Report

## 802.11n HT40 CH6

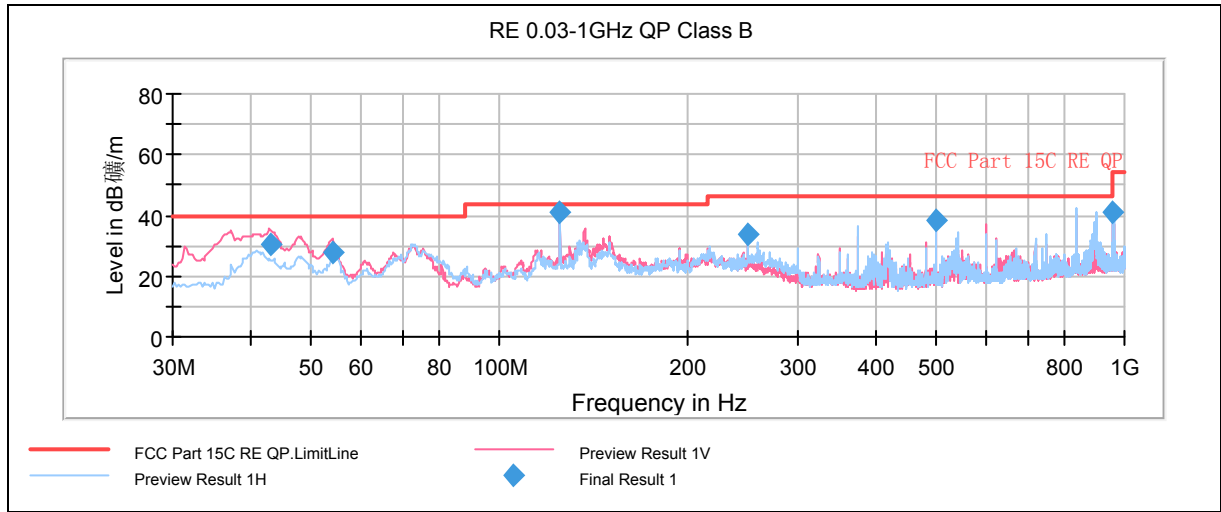

Radiates Emission from 30MHz to 1GHz

Frequency (MHz)	Quasi-Peak (dBuV/m)	Height (cm)	Polarization	Azimuth (deg)	Reading value (dBuV/m)	Correct Factor (dB)	Margin (dB)	Limit (dBuV/m)
42.972500	30.4	100.0	V	287.0	53.7	-23.3	9.6	40.0
54.047500	27.9	100.0	V	77.0	52.8	-24.9	12.1	40.0
125.020000	41.3	175.0	H	58.0	71.4	-30.1	2.2	43.5
249.987500	33.6	100.0	H	28.0	60.5	-26.9	12.4	46.0
500.005000	38.4	100.0	H	126.0	60	-21.6	7.6	46.0
959.987500	40.9	100.0	H	99.0	56.3	-15.4	5.1	46.0

**Remark: 1. Quasi-Peak = Reading value + Correction factor**

**2. Correction Factor = Antenna factor+ Insertion loss(cable loss+amplifier gain)**

**3. Margin = Limit – Quasi-Peak**

# TA Technology (Shanghai) Co., Ltd. Test Report

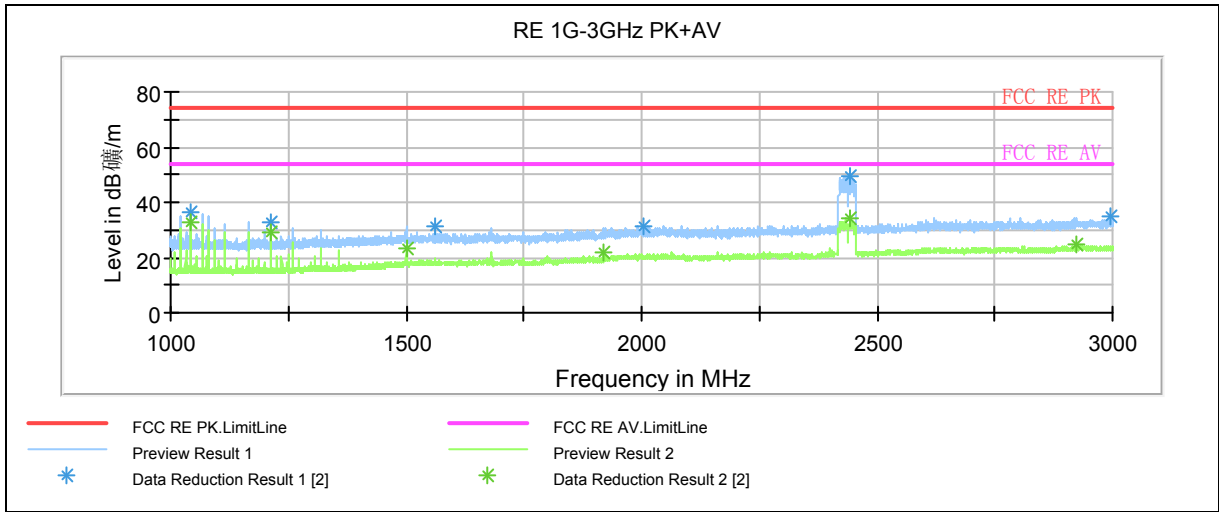

Note: The signal beyond the limit is carrier.  
Radiates Emission from 1GHz to 3GHz

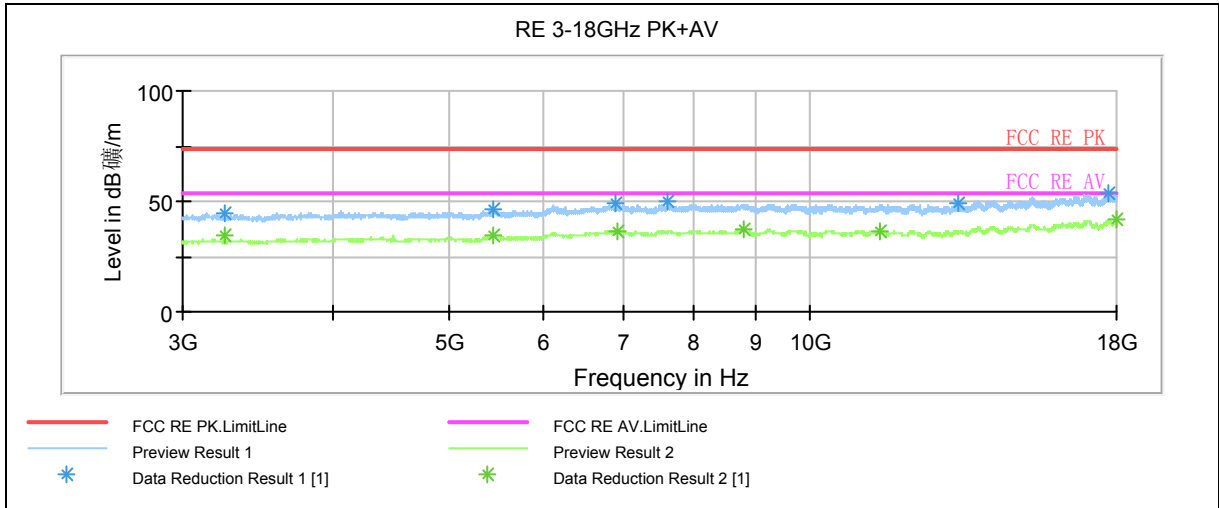

Radiates Emission from 3GHz to 18GHz

# TA Technology (Shanghai) Co., Ltd. Test Report

## 802.11n HT40 CH9

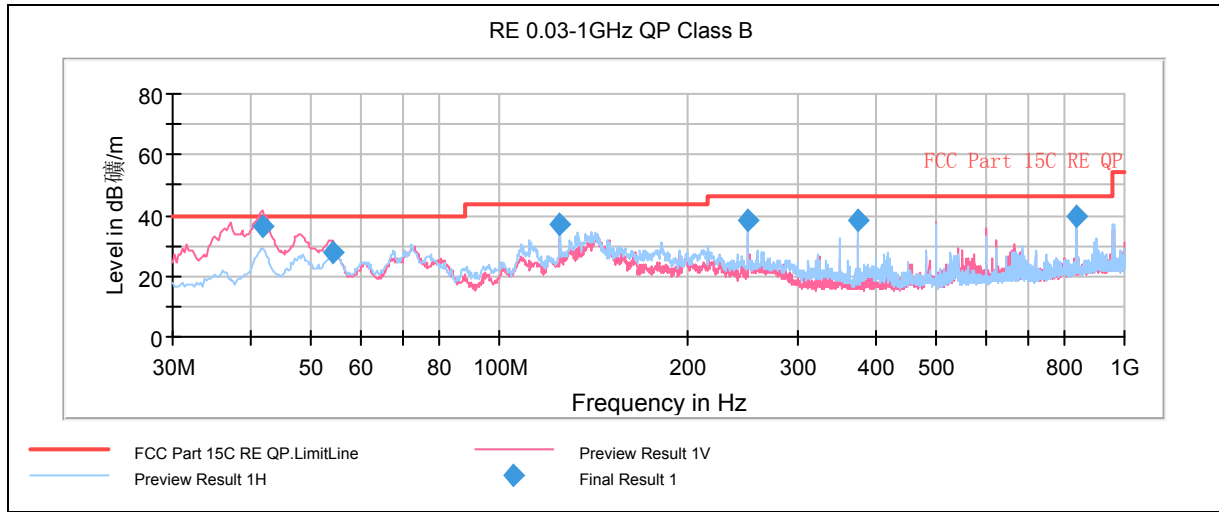

Radiates Emission from 30MHz to 1GHz

Frequency (MHz)	Quasi-Peak (dBuV/m)	Height (cm)	Polarization	Azimuth (deg)	Reading value (dBuV/m)	Correct Factor (dB)	Margin (dB)	Limit (dBuV/m)
41.682500	36.1	100.0	V	194.0	59.1	-23.0	3.9	40.0
54.090000	27.5	100.0	V	301.0	52.4	-24.9	12.5	40.0
125.020000	37.1	175.0	H	291.0	67.2	-30.1	6.4	43.5
249.987500	38.2	100.0	H	224.0	65.1	-26.9	7.8	46.0
374.997500	38.6	100.0	H	280.0	62.8	-24.2	7.4	46.0
839.992500	39.4	100.0	H	313.0	56	-16.6	6.6	46.0

**Remark: 1. Quasi-Peak = Reading value + Correction factor**

**2. Correction Factor = Antenna factor+ Insertion loss(cable loss+amplifier gain)**

**3. Margin = Limit – Quasi-Peak**



# TA Technology (Shanghai) Co., Ltd. Test Report

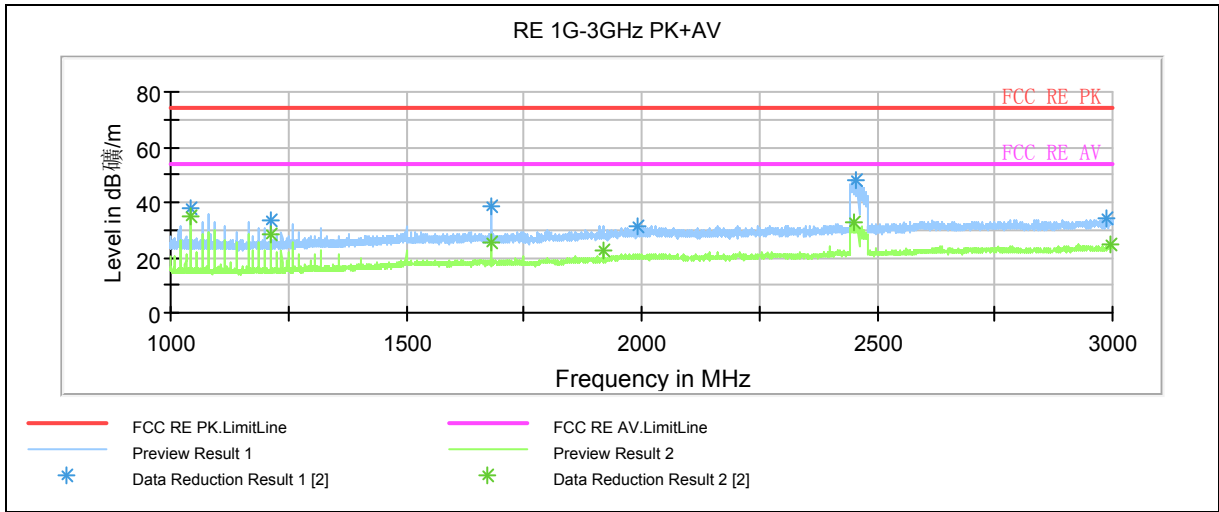

Note: The signal beyond the limit is carrier.  
Radiates Emission from 1GHz to 3GHz

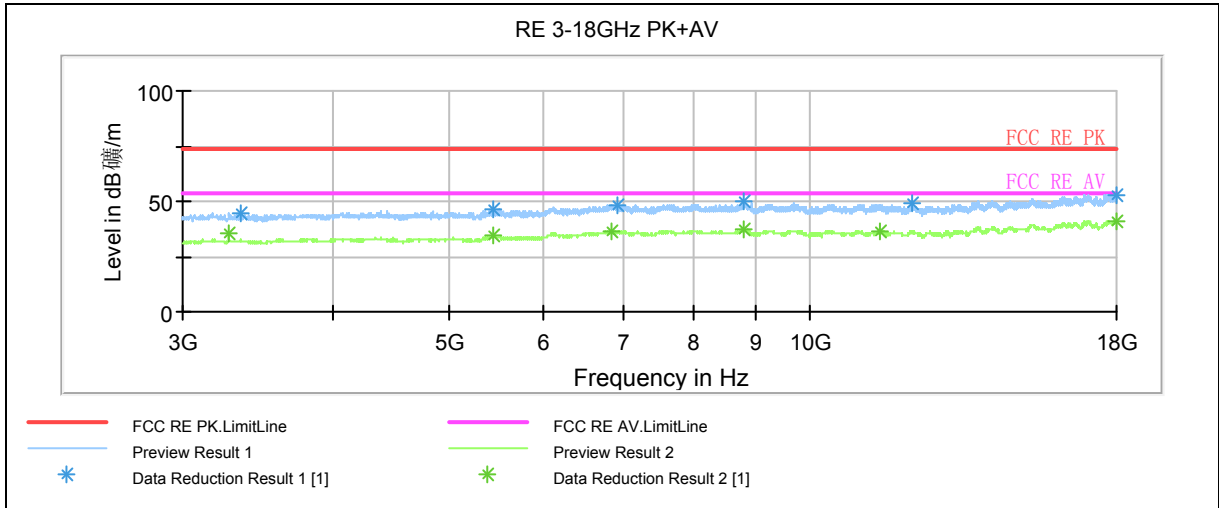

Radiates Emission from 3GHz to 18GHz

## 2.9. Conducted Emissions

### Ambient condition

Temperature	Relative humidity	Pressure
23°C ~25°C	45%~50%	101.5kPa

### Method of Measurement

The EUT IS placed on a non-metallic table of 80cm height above the horizontal metal reference ground plane. During the test, the EUT was operating in its typical mode. The test method is according to ANSIC63.4-2009. Connect the DC power line of the EUT to the LISN Use EMI receiver to detect the average and Quasi-peak value. RBW is set to 9kHz, VBW is set to 30kHz  
The measurement result should include both L line and N line.

The test is in transmitting mode.

### Test setup

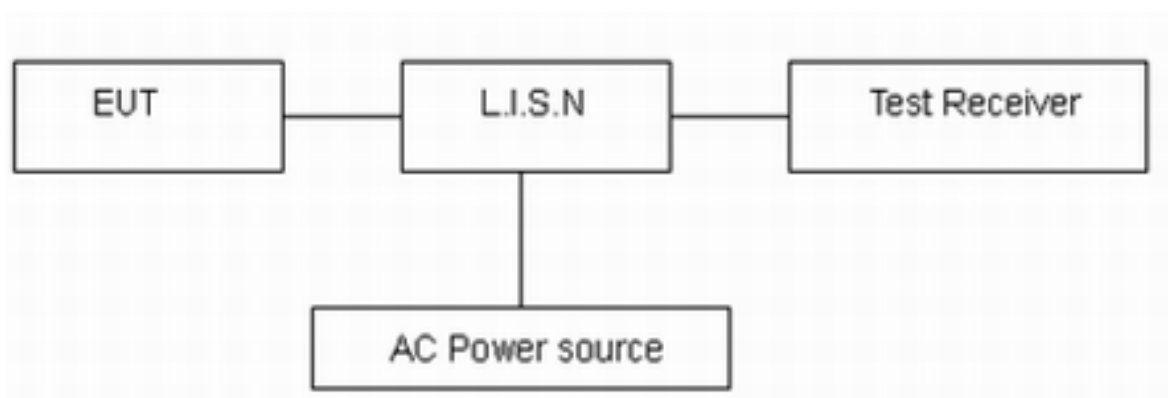

Note: DC Power source is used to change the voltage from 220V/50Hz to 110V/60Hz.

### Limits

Frequency (MHz)	Conducted Limits(dB $\mu$ V)	
	Quasi-peak	Average
0.15 - 0.5	66 to 56 *	56 to 46 *
0.5 - 5	56	46
5 - 30	60	50

\*: Decreases with the logarithm of the frequency.

### Measurement Uncertainty

The assessed measurement uncertainty to ensure 95% confidence level for the normal distribution is with the coverage factor  $k = 1.96$ ,  $U = 2.69$  dB.

# TA Technology (Shanghai) Co., Ltd. Test Report

Report No.: RZA1202-0233RF01R2

Page 83 of 109

## Test Results:

802.11b CH1

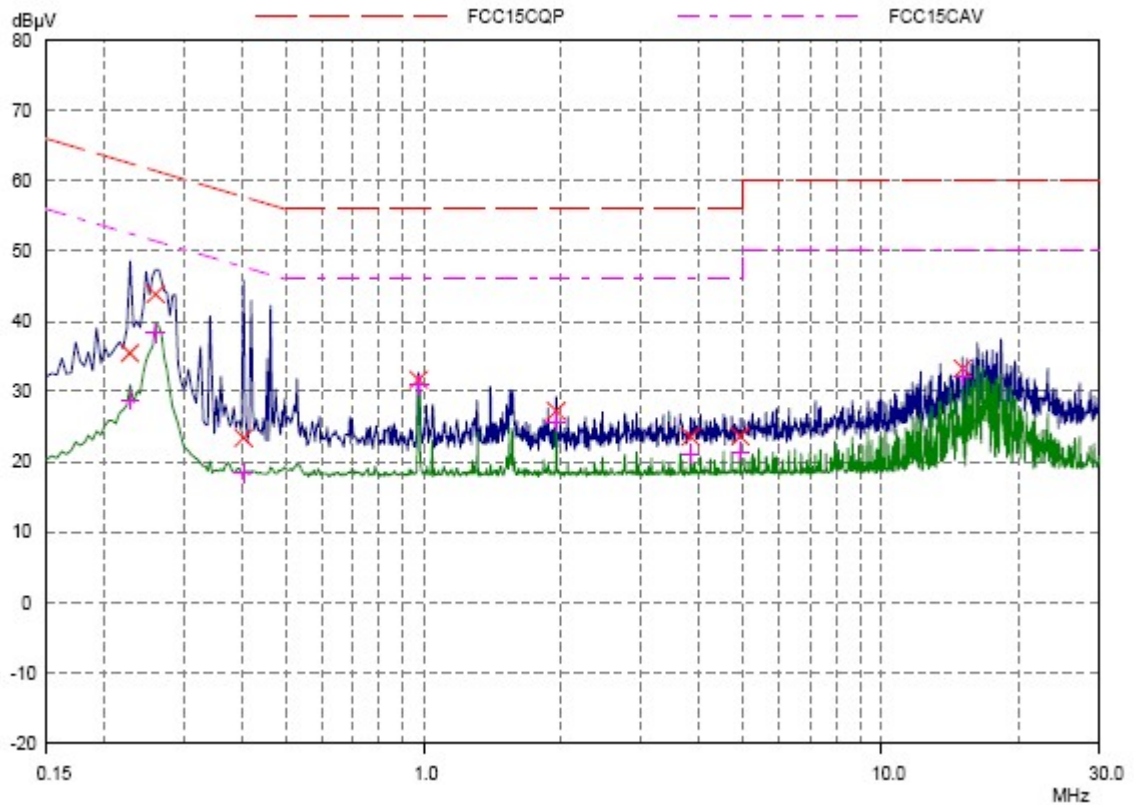

### L Line

#### Final Measurement Results

Frequency MHz	QP Level dBµV	QP Limit dBµV	QP Delta dB	Phase	PE
0.22812	35.44	62.52	27.08	L1	gnd
0.25937	43.88	61.45	17.57	L1	gnd
0.4039	23.38	57.77	34.39	L1	gnd
0.97421	31.68	56.00	24.32	L1	gnd
1.95078	27.22	56.00	28.78	L1	gnd
3.8375	23.52	56.00	32.48	L1	gnd
4.91953	23.62	56.00	32.38	L1	gnd
15.05625	33.28	60.00	26.74	L1	gnd

Frequency MHz	AV Level dBµV	AV Limit dBµV	AV Delta dB	Phase	PE
0.22812	28.84	52.52	23.68	L1	gnd
0.25937	38.30	51.45	13.15	L1	gnd
0.4039	18.33	47.77	29.44	L1	gnd
0.97421	30.95	46.00	15.05	L1	gnd
1.95078	25.62	46.00	20.38	L1	gnd
3.8375	21.14	46.00	24.86	L1	gnd
4.91953	21.39	46.00	24.61	L1	gnd
15.05625	32.28	50.00	17.72	L1	gnd

# TA Technology (Shanghai) Co., Ltd. Test Report

Report No.: RZA1202-0233RF01R2

Page 84of 109

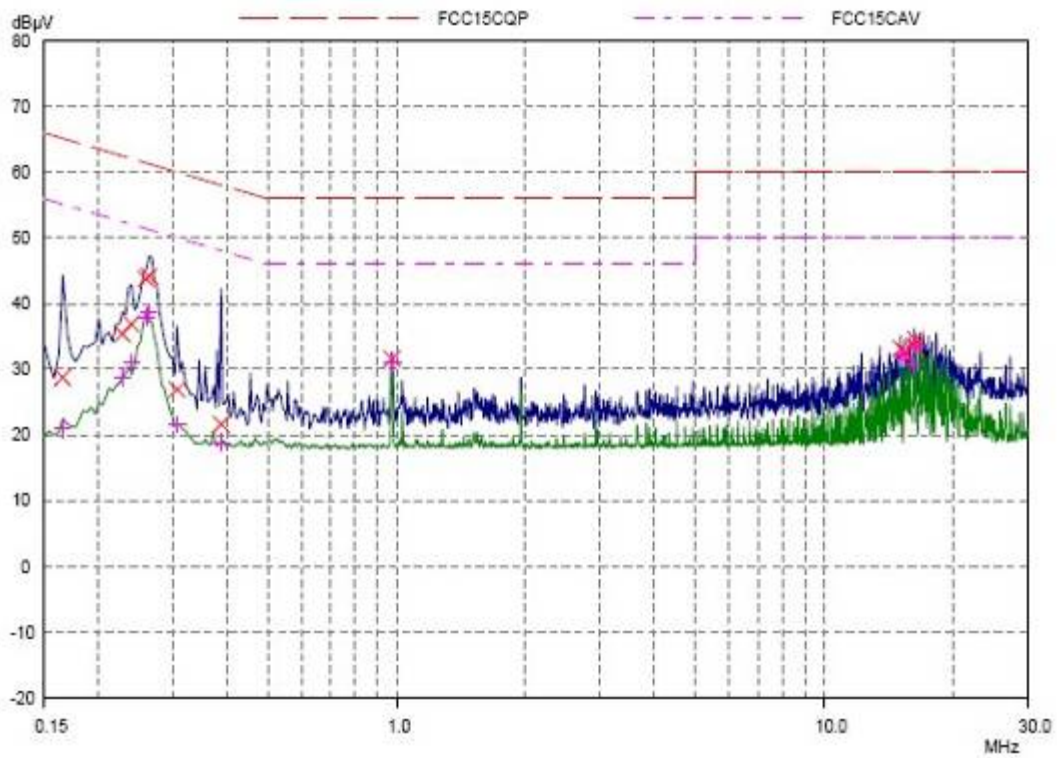

N Line

Final Measurement Results

Frequency MHz	QP Level dBµV	QP Limit dBµV	QP Delta dB	Phase -	PE -
0.16562	28.74	65.18	36.44	N	gnd
0.22812	35.40	62.52	27.12	N	gnd
0.23964	36.84	62.10	25.26	N	gnd
0.25937	43.76	61.45	17.69	N	gnd
0.26328	44.18	61.33	17.15	N	gnd
0.30625	28.88	60.07	33.19	N	gnd
0.36628	21.60	58.10	36.50	N	gnd
0.97421	31.62	50.00	24.38	N	gnd
15.05234	33.18	60.00	26.82	N	gnd
15.44887	32.68	60.00	27.32	N	gnd
16.23203	33.54	60.00	26.46	N	gnd
16.33359	34.50	60.00	25.50	N	gnd

Frequency MHz	AV Level dBµV	AV Limit dBµV	AV Delta dB	Phase -	PE -
0.16562	20.98	55.18	34.22	N	gnd
0.22812	28.79	52.52	23.73	N	gnd
0.23964	30.87	52.10	21.23	N	gnd
0.25937	37.95	51.45	13.50	N	gnd
0.26328	38.63	51.33	12.70	N	gnd
0.30625	21.57	50.07	28.50	N	gnd
0.36628	18.83	48.10	29.27	N	gnd
0.97421	30.87	40.00	15.13	N	gnd
15.05234	32.28	60.00	17.72	N	gnd

Final Measurement Results (continued)

Frequency MHz	AV Level dBµV	AV Limit dBµV	AV Delta dB	Phase -	PE -
15.44887	31.64	50.00	18.36	N	gnd
16.23203	30.62	50.00	19.38	N	gnd
16.33359	33.66	50.00	16.34	N	gnd

# TA Technology (Shanghai) Co., Ltd. Test Report

Report No.: RZA1202-0233RF01R2

Page 85of 109

802.11b CH6

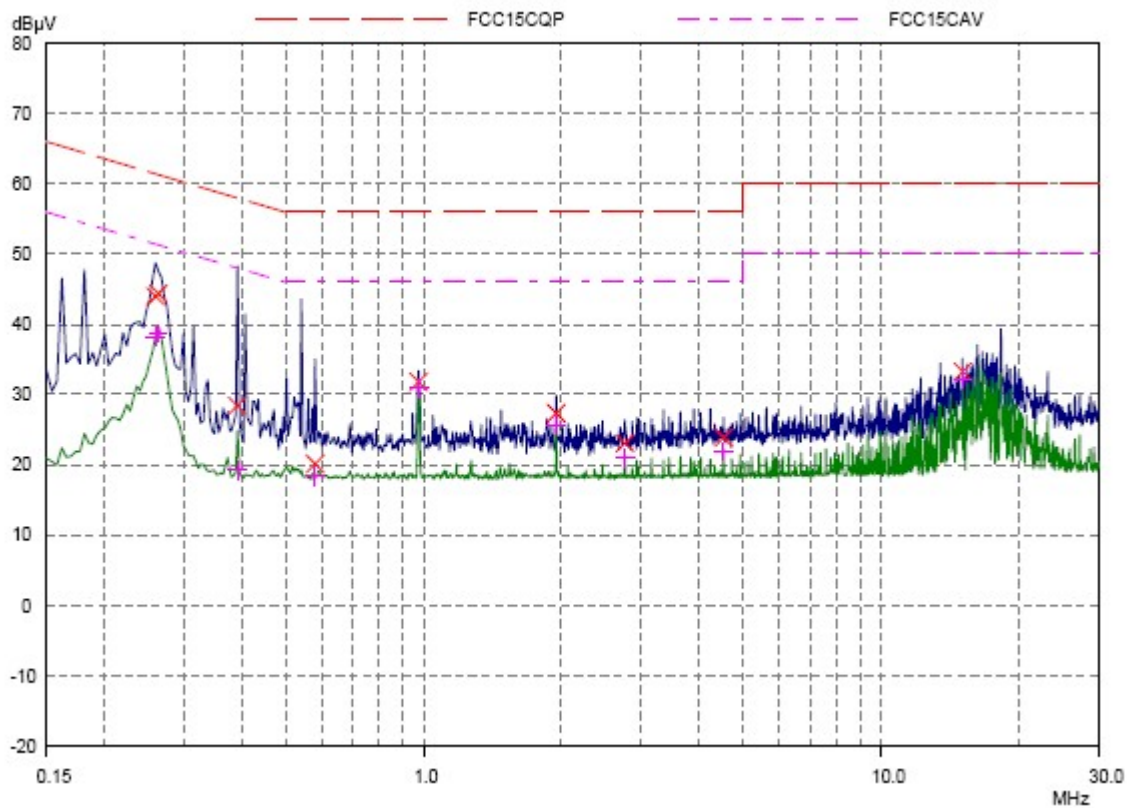

### L Line

#### Final Measurement Results

Frequency MHz	QP Level dBµV	QP Limit dBµV	QP Delta dB	Phase	PE
0.25937	43.98	61.45	17.47	L1	gnd
0.26328	44.38	61.33	16.97	L1	gnd
0.39218	28.36	58.02	29.66	L1	gnd
0.57968	20.12	58.00	35.88	L1	gnd
0.97421	31.80	58.00	24.20	L1	gnd
1.95078	27.34	58.00	28.66	L1	gnd
2.75548	23.08	58.00	32.92	L1	gnd
4.525	23.88	58.00	32.12	L1	gnd
15.05234	33.26	60.00	26.74	L1	gnd

  

Frequency MHz	AV Level dBµV	AV Limit dBµV	AV Delta dB	Phase	PE
0.25937	38.16	51.45	13.29	L1	gnd
0.26328	38.70	51.33	12.63	L1	gnd
0.39218	19.22	48.02	28.80	L1	gnd
0.57968	18.33	46.00	27.67	L1	gnd
0.97421	30.95	48.00	15.05	L1	gnd
1.95078	25.69	48.00	20.31	L1	gnd
2.75548	20.89	48.00	25.11	L1	gnd
4.525	21.80	48.00	24.20	L1	gnd
15.05234	32.21	50.00	17.79	L1	gnd

# TA Technology (Shanghai) Co., Ltd. Test Report

Report No.: RZA1202-0233RF01R2

Page 86of 109

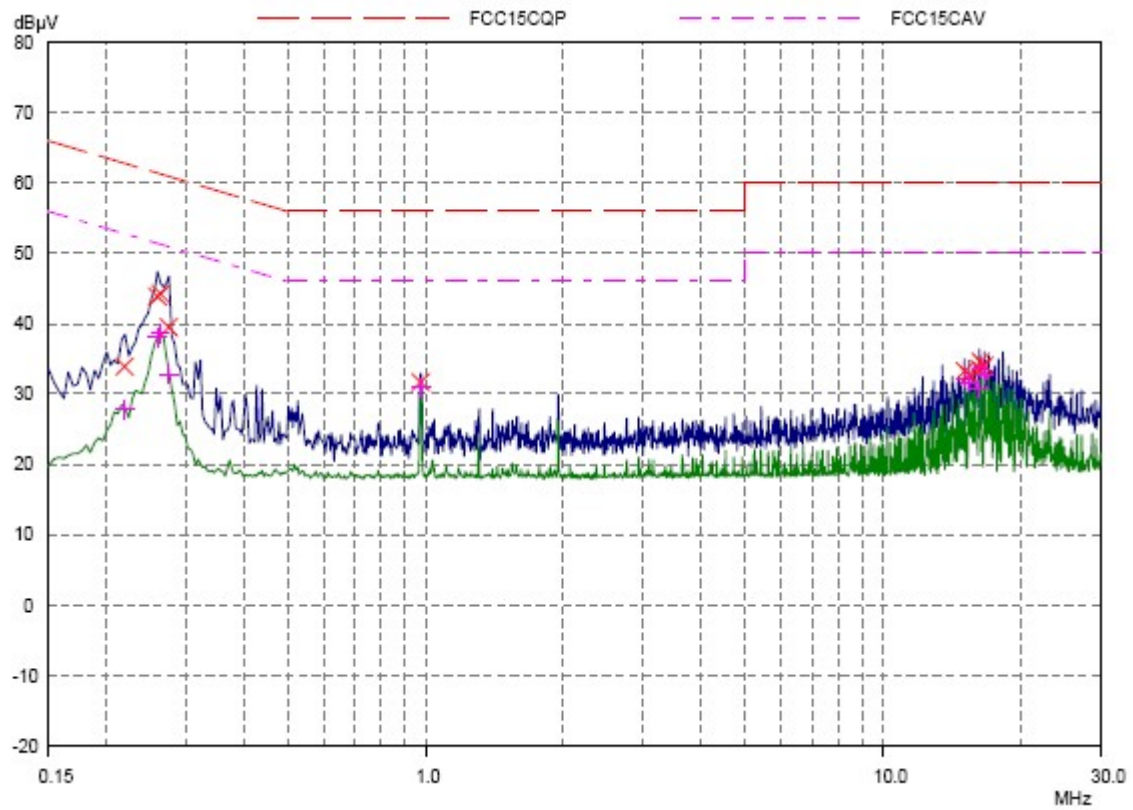

N Line

Final Measurement Results

Frequency MHz	QP Level dBµV	QP Limit dBµV	QP Delta dB	Phase -	PE -
0.22031	33.86	62.81	28.95	N	gnd
0.25937	43.86	61.45	17.59	N	gnd
0.26328	44.26	61.33	17.07	N	gnd
0.275	39.50	60.97	21.47	N	gnd
0.97421	31.70	56.00	24.30	N	gnd
15.05234	33.26	60.00	26.74	N	gnd
15.44687	32.88	60.00	27.32	N	gnd
16.23203	33.54	60.00	26.46	N	gnd
16.33359	34.54	60.00	25.46	N	gnd
16.62656	34.00	60.00	26.00	N	gnd

Frequency MHz	AV Level dBµV	AV Limit dBµV	AV Delta dB	Phase -	PE -
0.22031	27.76	52.81	25.05	N	gnd
0.25937	38.09	51.45	13.36	N	gnd
0.26328	38.63	51.33	12.70	N	gnd
0.275	32.74	50.97	18.23	N	gnd
0.97421	30.87	46.00	15.13	N	gnd
15.05234	32.21	50.00	17.79	N	gnd
15.44687	31.64	50.00	18.36	N	gnd
16.23203	30.71	50.00	19.29	N	gnd
16.33359	33.72	50.00	16.28	N	gnd
16.62656	32.81	50.00	17.19	N	gnd

# TA Technology (Shanghai) Co., Ltd. Test Report

Report No.: RZA1202-0233RF01R2

Page 87 of 109

802.11b CH11

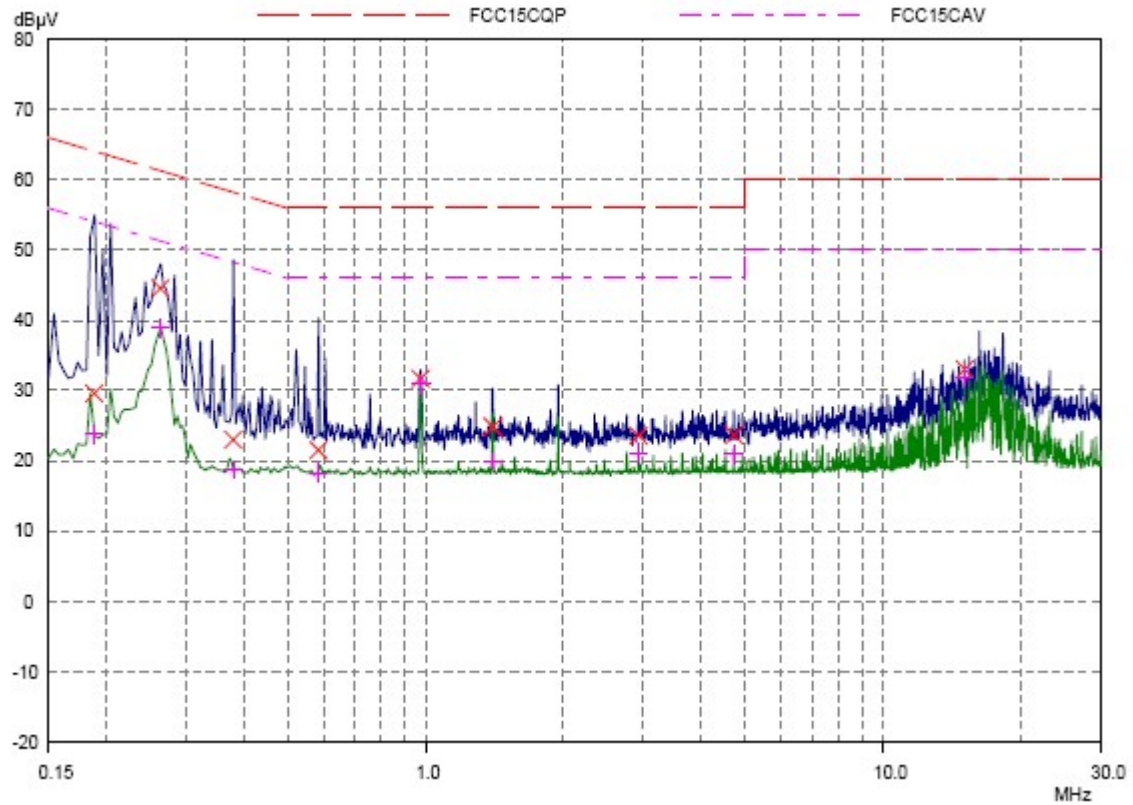

### L Line

#### Final Measurement Results

Frequency MHz	QP Level dBµV	QP Limit dBµV	QP Delta dB	Phase -	PE -
0.18908	29.58	64.08	34.52	L1	gnd
0.26328	44.58	61.33	16.77	L1	gnd
0.38048	22.98	58.27	35.29	L1	gnd
0.58359	21.48	58.00	34.52	L1	gnd
0.97421	31.68	58.00	24.34	L1	gnd
1.4	24.82	58.00	31.18	L1	gnd
2.92343	23.54	58.00	32.46	L1	gnd
4.72421	23.62	58.00	32.38	L1	gnd
15.05625	33.00	60.00	27.00	L1	gnd

Frequency MHz	AV Level dBµV	AV Limit dBµV	AV Delta dB	Phase -	PE -
0.18908	23.78	54.08	30.30	L1	gnd
0.26328	38.89	51.33	12.44	L1	gnd
0.38048	18.67	48.27	29.60	L1	gnd
0.58359	18.25	48.00	27.75	L1	gnd
0.97421	30.87	48.00	15.13	L1	gnd
1.4	19.82	48.00	28.18	L1	gnd
2.92343	21.08	48.00	24.92	L1	gnd
4.72421	20.89	48.00	25.11	L1	gnd
15.05625	32.00	50.00	18.00	L1	gnd

# TA Technology (Shanghai) Co., Ltd. Test Report

Report No.: RZA1202-0233RF01R2

Page 88of 109

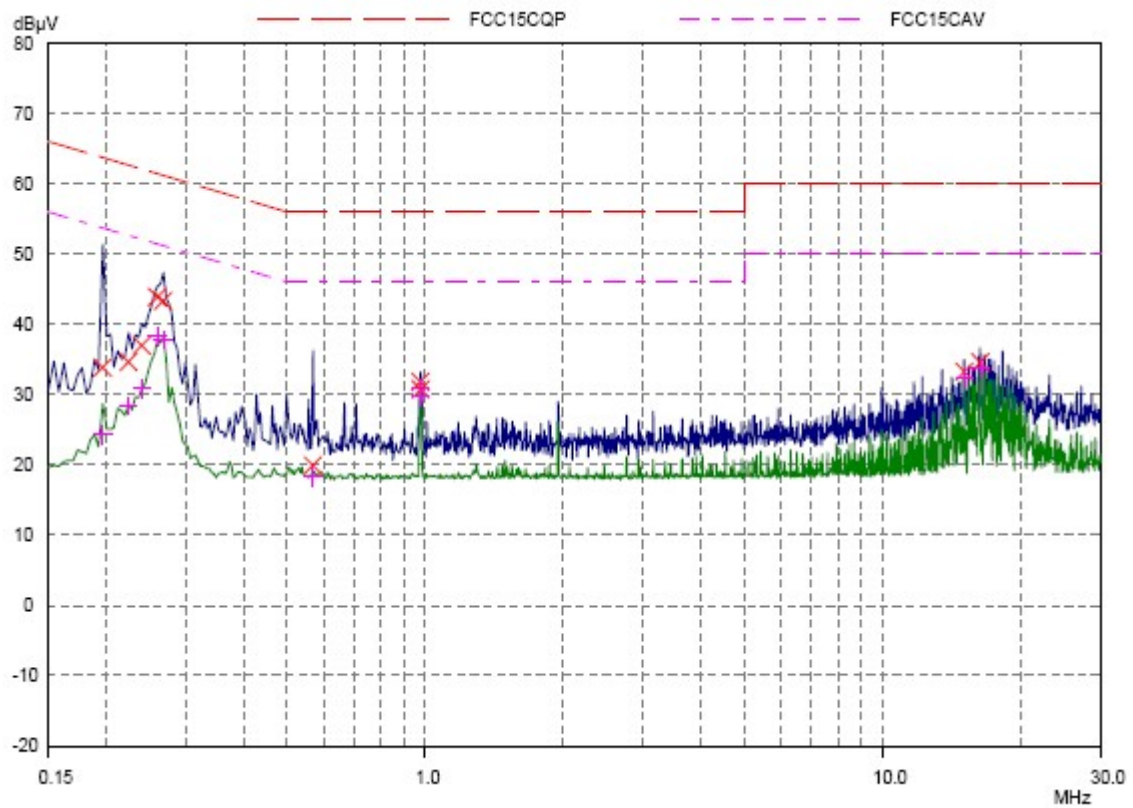

## N Line

### Final Measurement Results

Frequency MHz	QP Level dBµV	QP Limit dBµV	QP Delta dB	Phase -	PE -
0.19687	33.80	63.74	29.94	N	gnd
0.22421	34.62	62.66	28.04	N	gnd
0.23984	36.94	62.10	25.16	N	gnd
0.25937	43.88	61.45	17.59	N	gnd
0.26718	43.28	61.21	17.93	N	gnd
0.56796	19.94	56.00	36.06	N	gnd
0.97421	31.82	56.00	24.18	N	gnd
0.97812	30.76	56.00	25.24	N	gnd
15.05234	33.26	60.00	26.74	N	gnd
16.33359	34.54	60.00	25.46	N	gnd

Frequency MHz	AV Level dBµV	AV Limit dBµV	AV Delta dB	Phase -	PE -
0.19687	24.27	53.74	29.47	N	gnd
0.22421	28.37	52.66	24.29	N	gnd
0.23984	30.87	52.10	21.23	N	gnd
0.25937	38.23	51.45	13.22	N	gnd
0.26718	37.73	51.21	13.48	N	gnd
0.56796	18.25	46.00	27.75	N	gnd
0.97421	30.87	46.00	15.13	N	gnd
0.97812	29.66	46.00	16.34	N	gnd
15.05234	32.28	50.00	17.72	N	gnd
16.33359	33.72	50.00	16.28	N	gnd



# TA Technology (Shanghai) Co., Ltd. Test Report

Report No.: RZA1202-0233RF01R2

Page 89of 109

802.11g CH1

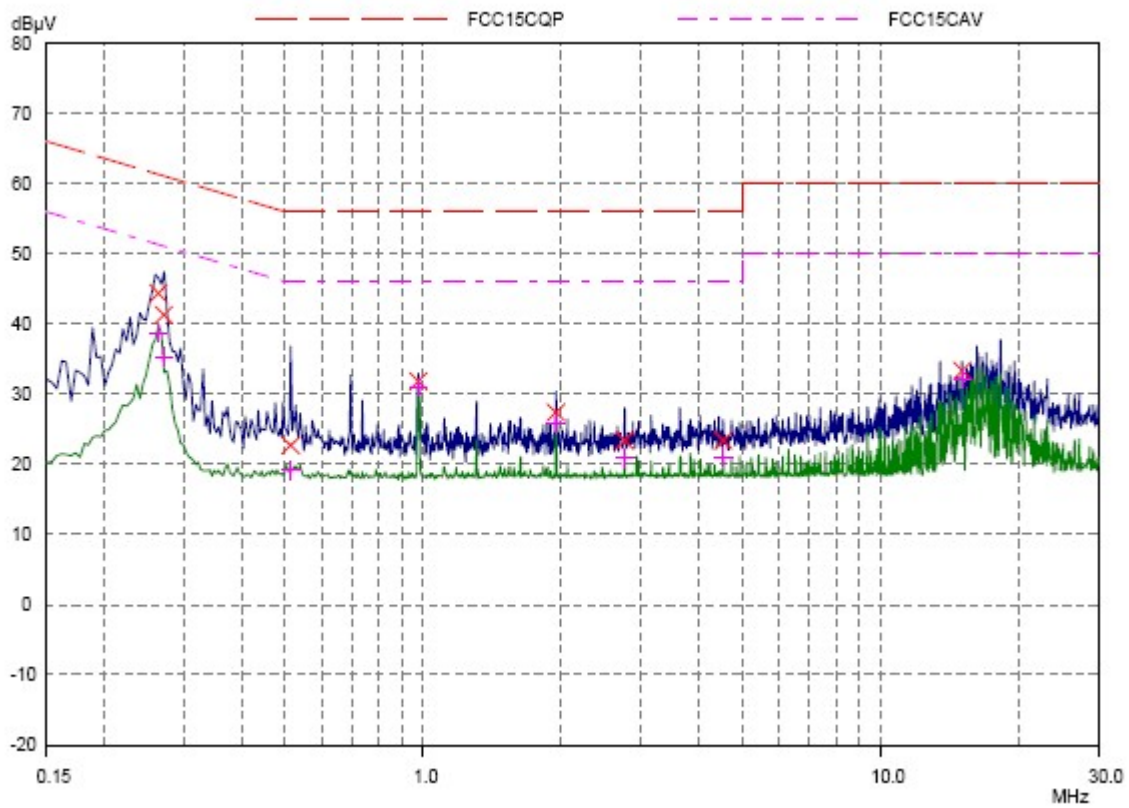

### L Line

#### Final Measurement Results

Frequency MHz	QP Level dBμV	QP Limit dBμV	QP Delta dB	Phase -	PE -
0.26328	44.34	61.33	16.99	L1	gnd
0.27109	41.26	61.08	19.82	L1	gnd
0.51327	22.64	56.00	33.36	L1	gnd
0.97421	31.82	56.00	24.18	L1	gnd
1.95078	27.36	56.00	28.64	L1	gnd
2.75546	23.40	56.00	32.60	L1	gnd
4.5289	23.38	56.00	32.62	L1	gnd
15.05234	33.32	60.00	26.68	L1	gnd

Frequency MHz	AV Level dBμV	AV Limit dBμV	AV Delta dB	Phase -	PE -
0.26328	38.70	51.33	12.63	L1	gnd
0.27109	35.35	51.08	15.73	L1	gnd
0.51327	19.14	46.00	26.86	L1	gnd
0.97421	30.95	46.00	15.05	L1	gnd
1.95078	25.76	46.00	20.24	L1	gnd
2.75546	20.83	46.00	25.17	L1	gnd
4.5289	21.02	46.00	24.98	L1	gnd
15.05234	32.21	50.00	17.79	L1	gnd

# TA Technology (Shanghai) Co., Ltd. Test Report

Report No.: RZA1202-0233RF01R2

Page 90 of 109

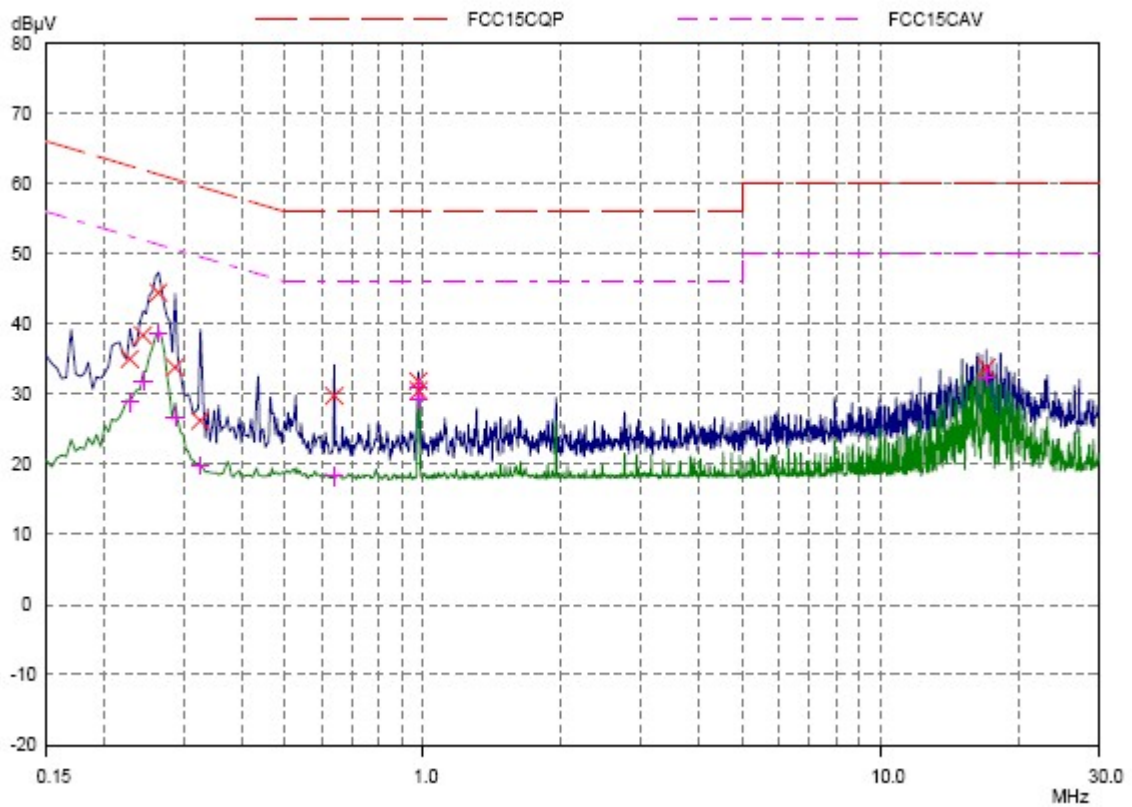

## N Line

### Final Measurement Results

Frequency MHz	QP Level dBµV	QP Limit dBµV	QP Delta dB	Phase -	PE -
0.22812	34.96	62.52	27.56	N	gnd
0.24375	38.36	61.97	23.61	N	gnd
0.26328	44.42	61.33	16.91	N	gnd
0.28671	33.80	60.62	26.82	N	gnd
0.32578	26.22	59.56	33.34	N	gnd
0.63828	29.76	56.00	26.24	N	gnd
0.97421	31.86	56.00	24.14	N	gnd
0.97812	30.48	56.00	25.52	N	gnd
17.02109	33.70	60.00	26.30	N	gnd

Frequency MHz	AV Level dBµV	AV Limit dBµV	AV Delta dB	Phase -	PE -
0.22812	28.79	52.52	23.73	N	gnd
0.24375	31.86	51.97	20.11	N	gnd
0.26328	38.63	51.33	12.70	N	gnd
0.28671	26.79	50.62	23.83	N	gnd
0.32578	19.82	49.56	29.74	N	gnd
0.63828	18.25	46.00	27.75	N	gnd
0.97421	30.87	46.00	15.13	N	gnd
0.97812	29.19	46.00	16.81	N	gnd
17.02109	32.41	50.00	17.59	N	gnd

# TA Technology (Shanghai) Co., Ltd. Test Report

Report No.: RZA1202-0233RF01R2

Page 91 of 109

802.11g CH6

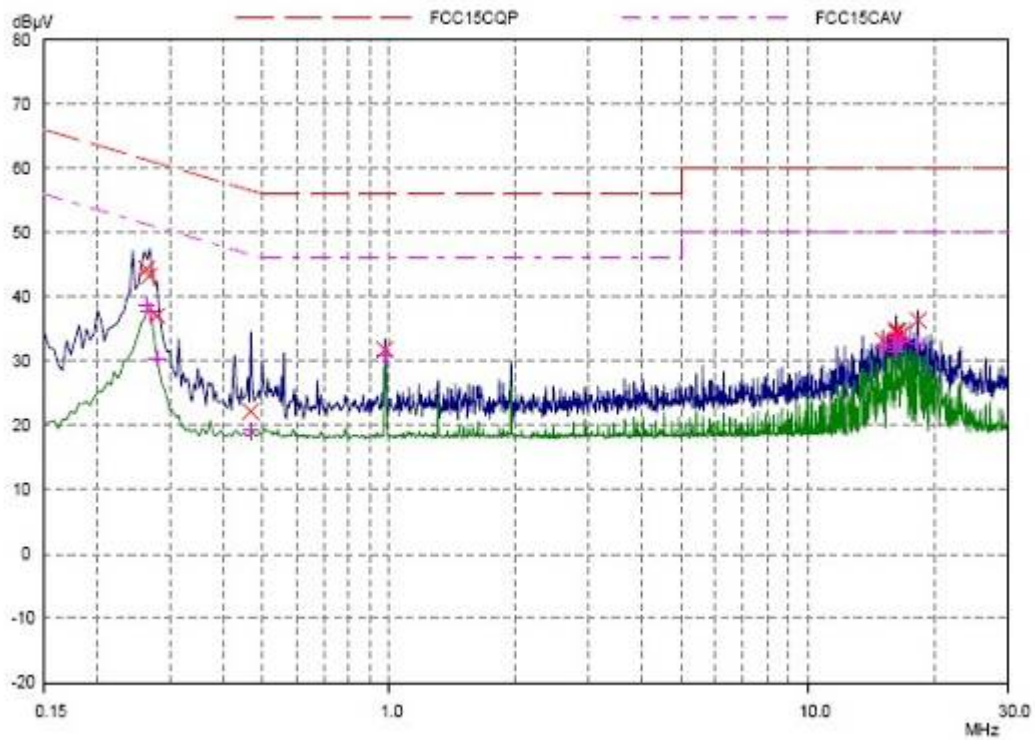

L Line

Final Measurement Results

Frequency MHz	QP Level dBμV	QP Limit dBμV	QP Delta dB	Phase	PE
0.26328	44.32	61.33	17.01	L1	gnd
0.26718	43.24	61.21	17.97	L1	gnd
0.2769	37.04	60.85	23.81	L1	gnd
0.4664	22.16	56.58	34.42	L1	gnd
0.97421	31.78	56.00	24.22	L1	gnd
15.05234	33.24	60.00	26.76	L1	gnd
16.22812	34.40	60.00	25.60	L1	gnd
16.23203	34.78	60.00	25.22	L1	gnd
16.33359	34.56	60.00	25.44	L1	gnd
16.63046	34.08	60.00	25.92	L1	gnd
18.30234	36.34	60.00	23.66	L1	gnd

Frequency MHz	AV Level dBμV	AV Limit dBμV	AV Delta dB	Phase	PE
0.26328	38.83	51.33	12.70	L1	gnd
0.26718	37.66	51.21	13.55	L1	gnd
0.2769	30.37	50.85	20.48	L1	gnd
0.4664	19.14	46.58	27.44	L1	gnd
0.97421	30.87	46.00	15.13	L1	gnd
15.05234	32.21	50.00	17.79	L1	gnd
16.22812	32.61	50.00	17.39	L1	gnd
16.23203	31.49	50.00	18.51	L1	gnd
16.33359	33.66	50.00	16.34	L1	gnd
16.63046	32.93	50.00	17.07	L1	gnd

Final Measurement Results (continued)

Frequency MHz	AV Level dBμV	AV Limit dBμV	AV Delta dB	Phase	PE
18.30234	32.61	50.00	17.39	L1	gnd

# TA Technology (Shanghai) Co., Ltd. Test Report

Report No.: RZA1202-0233RF01R2

Page 92 of 109

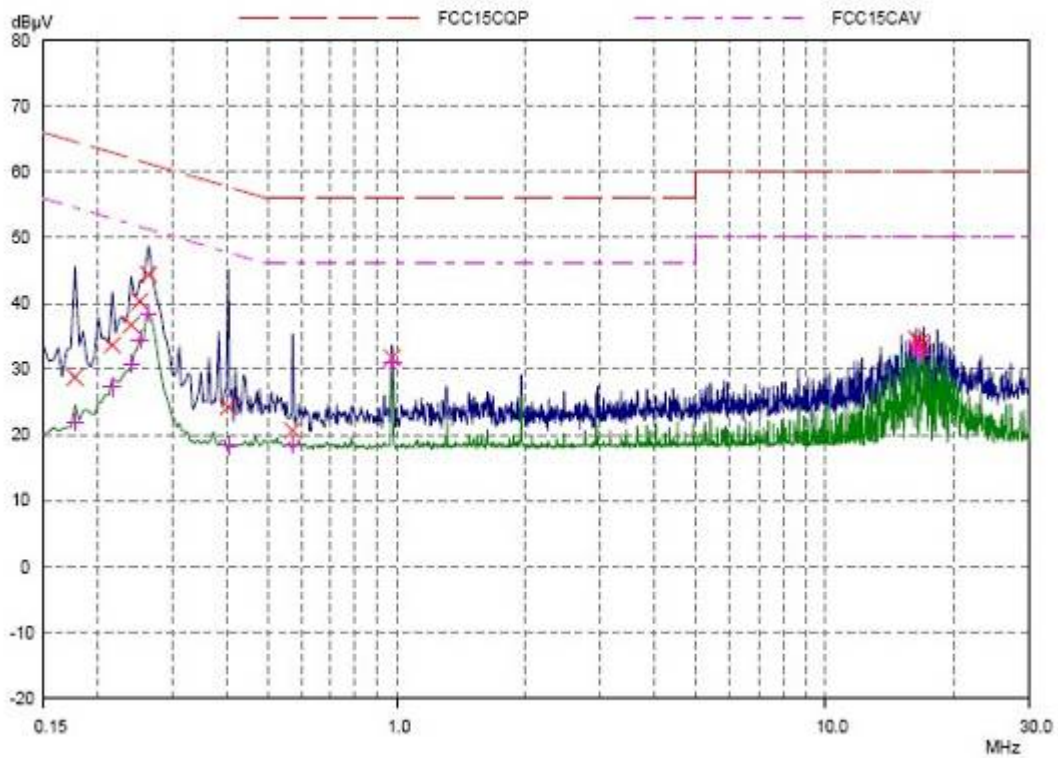

### N Line

#### Final Measurement Results

Frequency MHz	QP Level dBµV	QP Limit dBµV	QP Delta dB	Phase -	PE -
0.17734	28.74	64.61	35.87	N	gnd
0.2164	33.64	62.96	29.32	N	gnd
0.23984	36.70	62.10	25.40	N	gnd
0.25156	40.28	61.71	21.43	N	gnd
0.26328	44.38	61.33	16.95	N	gnd
0.4039	24.24	57.77	33.53	N	gnd
0.57167	20.62	56.00	35.38	N	gnd
0.97421	31.74	56.00	24.26	N	gnd
16.33359	34.58	60.00	25.42	N	gnd
16.63046	34.04	60.00	25.96	N	gnd
16.72612	33.34	60.00	26.66	N	gnd

Frequency MHz	AV Level dBµV	AV Limit dBµV	AV Delta dB	Phase -	PE -
0.17734	21.97	54.61	32.64	N	gnd
0.2164	27.23	52.96	25.73	N	gnd
0.23984	30.79	52.10	21.31	N	gnd
0.25156	34.55	51.71	17.16	N	gnd
0.26328	38.57	51.33	12.76	N	gnd
0.4039	18.33	47.77	29.44	N	gnd
0.57167	18.42	46.00	27.58	N	gnd
0.97421	30.87	46.00	15.13	N	gnd
16.33359	33.72	50.00	16.28	N	gnd
16.63046	33.00	50.00	17.00	N	gnd

#### Final Measurement Results (continued)

Frequency MHz	AV Level dBµV	AV Limit dBµV	AV Delta dB	Phase -	PE -
16.72612	32.28	50.00	17.72	N	gnd

# TA Technology (Shanghai) Co., Ltd. Test Report

Report No.: RZA1202-0233RF01R2

Page 93 of 109

802.11g CH11

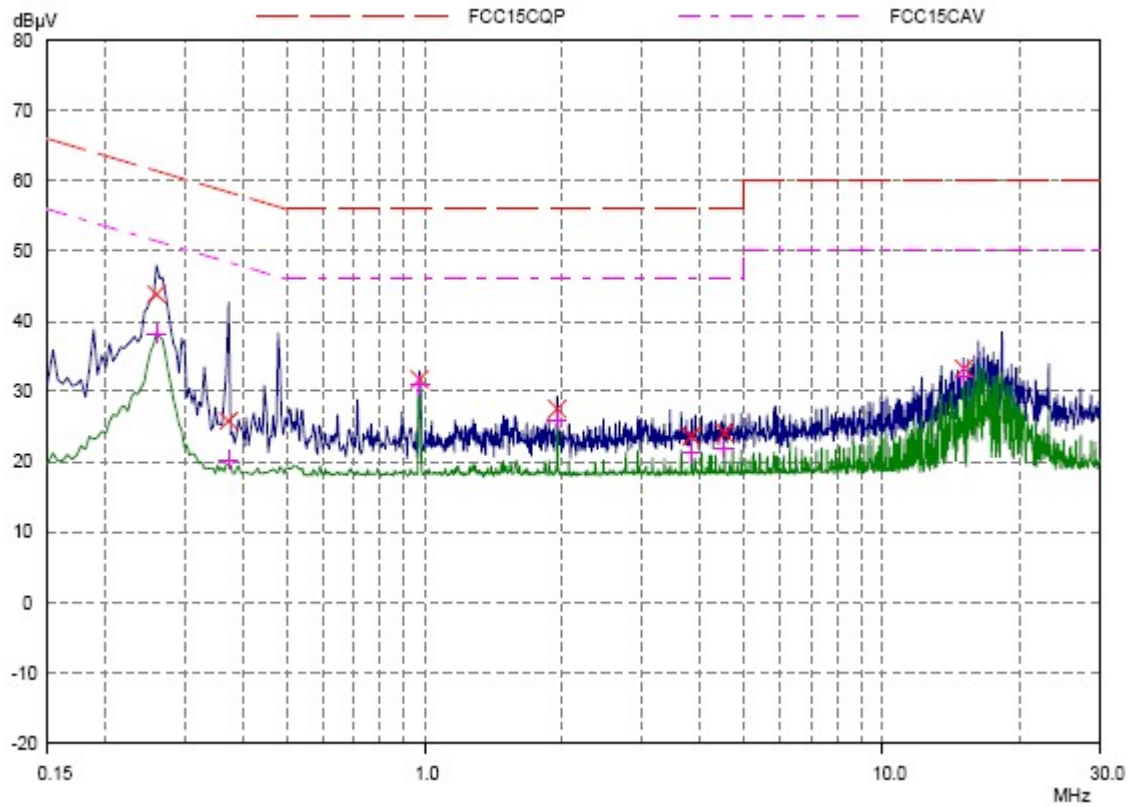

## L Line

### Final Measurement Results

Frequency MHz	QP Level dBuV	QP Limit dBuV	QP Delta dB	Phase -	PE -
0.25937	43.88	61.45	17.57	L1	gnd
0.37265	25.78	58.44	32.66	L1	gnd
0.97421	31.74	56.00	24.26	L1	gnd
1.95078	27.48	56.00	28.52	L1	gnd
3.8375	23.62	56.00	32.38	L1	gnd
4.525	24.04	56.00	31.96	L1	gnd
15.05234	33.24	60.00	26.76	L1	gnd

Frequency MHz	AV Level dBuV	AV Limit dBuV	AV Delta dB	Phase -	PE -
0.25937	38.16	51.45	13.29	L1	gnd
0.37265	20.24	48.44	28.20	L1	gnd
0.97421	30.87	46.00	15.13	L1	gnd
1.95078	25.84	46.00	20.16	L1	gnd
3.8375	21.21	46.00	24.79	L1	gnd
4.525	21.80	46.00	24.20	L1	gnd
15.05234	32.21	50.00	17.79	L1	gnd

# TA Technology (Shanghai) Co., Ltd. Test Report

Report No.: RZA1202-0233RF01R2

Page 94 of 109

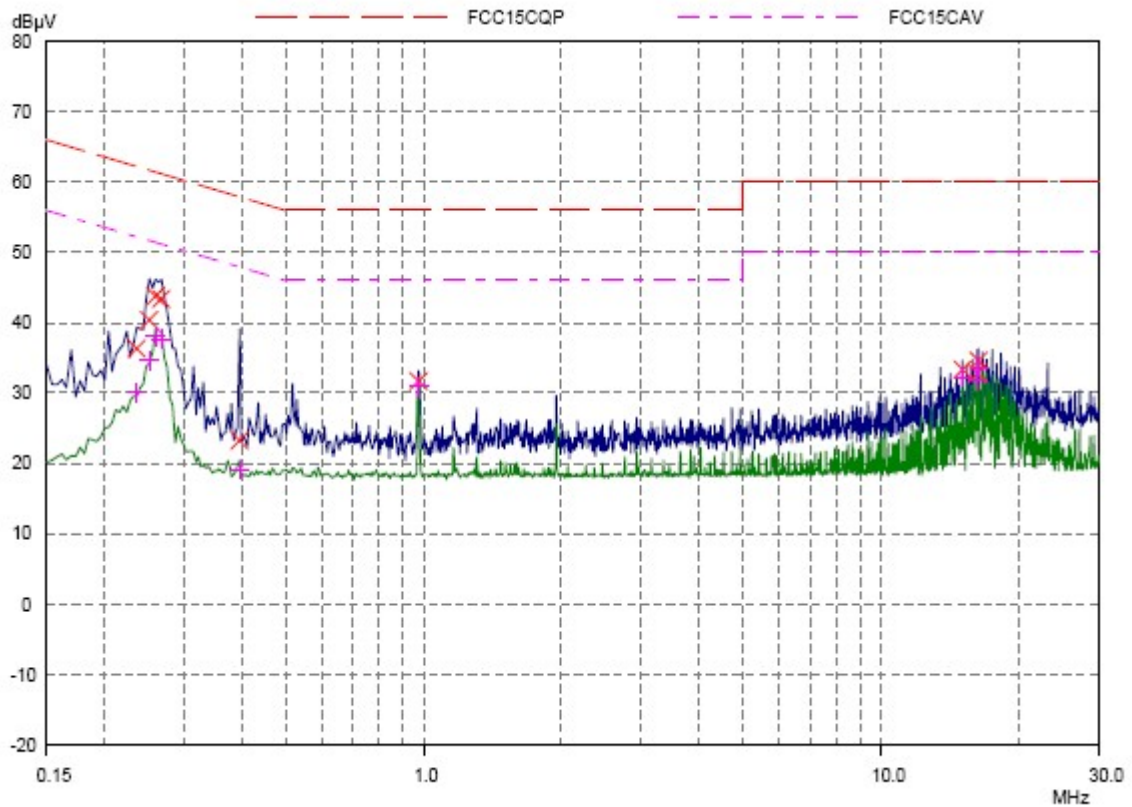

### N Line

#### Final Measurement Results

Frequency MHz	QP Level dBµV	QP Limit dBµV	QP Delta dB	Phase -	PE -
0.23593	36.30	62.24	25.94	N	gnd
0.25156	40.38	61.71	21.33	N	gnd
0.25937	43.78	61.45	17.67	N	gnd
0.26718	43.36	61.21	17.85	N	gnd
0.39609	23.24	57.93	34.69	N	gnd
0.97421	31.70	56.00	24.30	N	gnd
15.05625	33.34	60.00	26.66	N	gnd
16.23593	32.80	60.00	27.20	N	gnd
16.33359	34.58	60.00	25.42	N	gnd

Frequency MHz	AV Level dBµV	AV Limit dBµV	AV Delta dB	Phase -	PE -
0.23593	30.07	52.24	22.17	N	gnd
0.25156	34.60	51.71	17.11	N	gnd
0.25937	38.09	51.45	13.36	N	gnd
0.26718	37.66	51.21	13.55	N	gnd
0.39609	18.99	47.93	28.94	N	gnd
0.97421	30.87	46.00	15.13	N	gnd
15.05625	32.28	50.00	17.72	N	gnd
16.23593	31.71	50.00	18.29	N	gnd
16.33359	33.66	50.00	16.34	N	gnd

# TA Technology (Shanghai) Co., Ltd. Test Report

Report No.: RZA1202-0233RF01R2

Page 95of 109

802.11n HT20 CH1

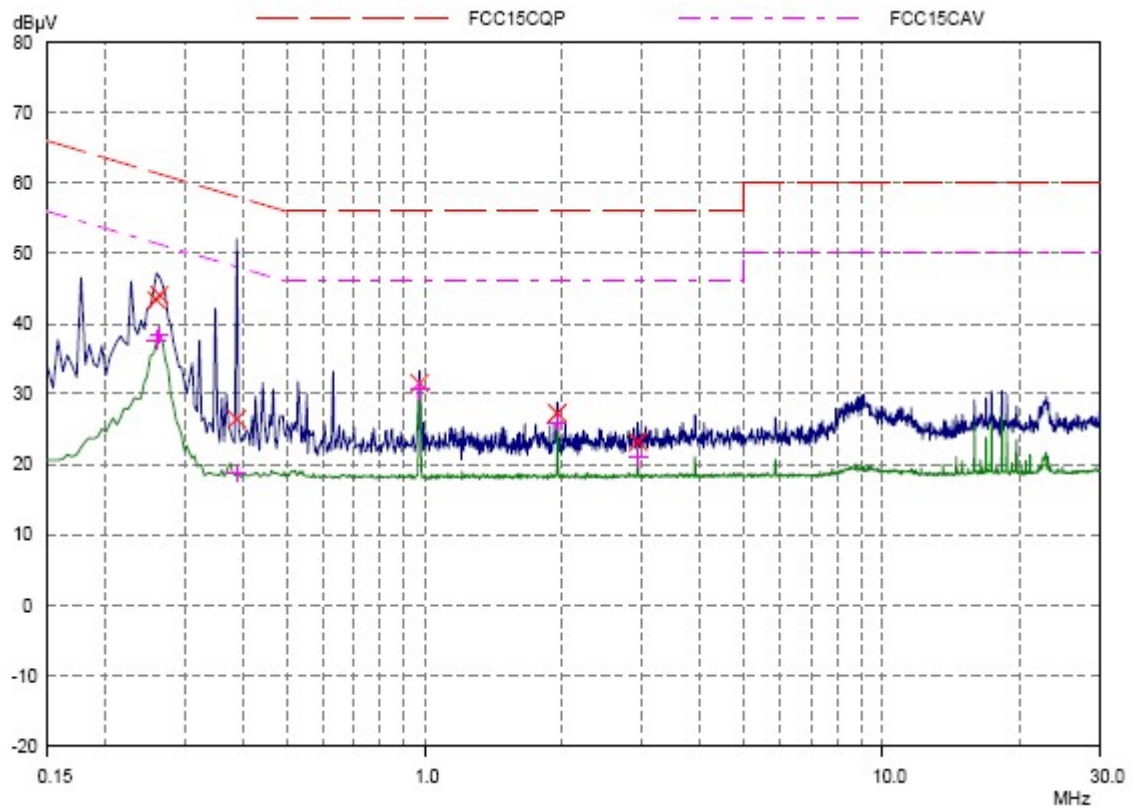

## L Line

### Final Measurement Results

Frequency MHz	QP Level dBµV	QP Limit dBµV	QP Delta dB	Phase -	PE -
0.25937	43.38	61.45	18.07	L1	gnd
0.26328	44.04	61.33	17.29	L1	gnd
0.38828	26.40	58.10	31.70	L1	gnd
0.97421	31.48	56.00	24.52	L1	gnd
1.95078	27.26	56.00	28.74	L1	gnd
2.92734	23.18	56.00	32.82	L1	gnd

  

Frequency MHz	AV Level dBµV	AV Limit dBµV	AV Delta dB	Phase -	PE -
0.25937	37.66	51.45	13.79	L1	gnd
0.26328	38.43	51.33	12.90	L1	gnd
0.38828	18.75	48.10	29.35	L1	gnd
0.97421	30.62	46.00	15.38	L1	gnd
1.95078	25.84	46.00	20.16	L1	gnd
2.92734	20.96	46.00	25.04	L1	gnd

# TA Technology (Shanghai) Co., Ltd. Test Report

Report No.: RZA1202-0233RF01R2

Page 96 of 109

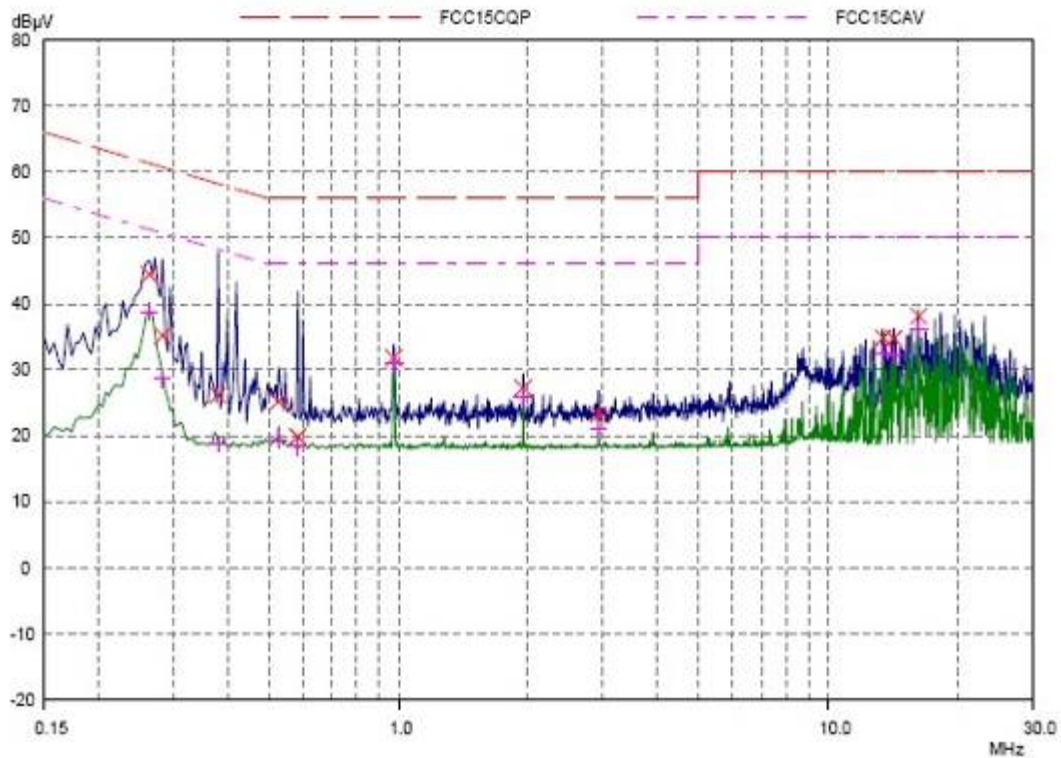

### N Line

#### Final Measurement Results

Frequency MHz	QP Level dBµV	QP Limit dBµV	QP Delta dB	Phase -	PE -
0.26328	44.42	61.33	16.91	N	gnd
0.26261	35.16	60.73	25.57	N	gnd
0.38046	26.10	58.27	32.17	N	gnd
0.525	25.20	56.00	30.80	N	gnd
0.58359	19.88	56.00	36.14	N	gnd
0.97421	31.80	56.00	24.20	N	gnd
1.95078	27.24	56.00	28.76	N	gnd
2.92343	23.22	56.00	32.78	N	gnd
13.41953	34.84	60.00	25.16	N	gnd
14.2125	34.72	60.00	25.28	N	gnd
16.22812	38.12	60.00	21.88	N	gnd

Frequency MHz	AV Level dBµV	AV Limit dBµV	AV Delta dB	Phase -	PE -
0.26328	38.83	51.33	12.50	N	gnd
0.26261	28.58	50.73	22.15	N	gnd
0.38046	18.67	48.27	29.60	N	gnd
0.525	19.37	46.00	26.63	N	gnd
0.58359	18.33	46.00	27.67	N	gnd
0.97421	30.95	46.00	15.05	N	gnd
1.95078	25.76	46.00	20.24	N	gnd
2.92343	20.96	46.00	25.04	N	gnd
13.41953	32.34	50.00	17.66	N	gnd
14.2125	32.28	50.00	17.72	N	gnd

#### Final Measurement Results (continued)

Frequency MHz	AV Level dBµV	AV Limit dBµV	AV Delta dB	Phase -	PE -
16.22812	36.09	50.00	13.91	N	gnd



# TA Technology (Shanghai) Co., Ltd. Test Report

Report No.: RZA1202-0233RF01R2

Page 97 of 109

802.11n HT20 CH6

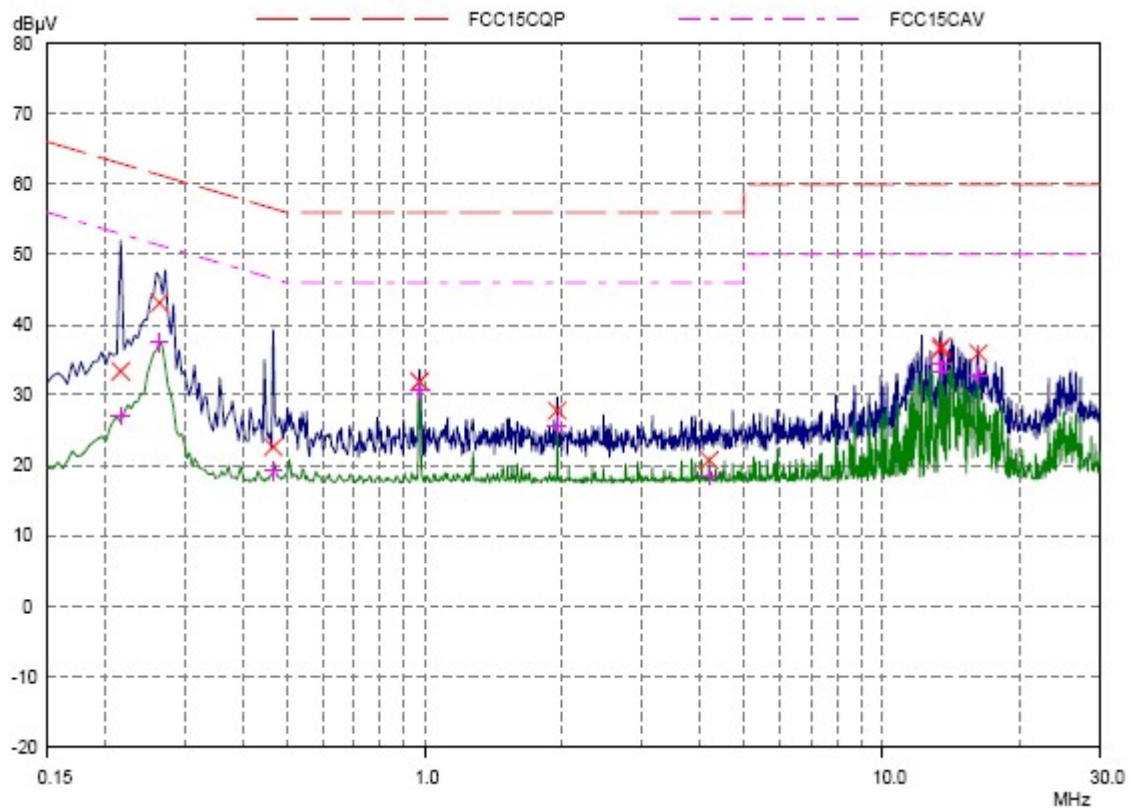

## L Line

### Final Measurement Results

Frequency MHz	QP Level dBµV	QP Limit dBµV	QP Delta dB	Phase -	PE -
0.2164	33.38	62.96	29.60	L1	gnd
0.26328	43.10	61.33	18.23	L1	gnd
0.4664	22.62	56.58	33.96	L1	gnd
0.97421	31.88	56.00	24.12	L1	gnd
1.95078	27.74	56.00	28.26	L1	gnd
4.18905	20.72	56.00	35.28	L1	gnd
13.41953	36.50	60.00	23.50	L1	gnd
13.48203	36.86	60.00	23.14	L1	gnd
16.22812	35.90	60.00	24.10	L1	gnd

Frequency MHz	AV Level dBµV	AV Limit dBµV	AV Delta dB	Phase -	PE -
0.2164	26.98	52.96	25.98	L1	gnd
0.26328	37.43	51.33	13.90	L1	gnd
0.4664	19.22	46.58	27.36	L1	gnd
0.97421	30.71	46.00	15.29	L1	gnd
1.95078	25.69	46.00	20.31	L1	gnd
4.18905	18.42	46.00	27.58	L1	gnd
13.41953	34.44	50.00	15.56	L1	gnd
13.48203	33.37	50.00	16.63	L1	gnd
16.22812	32.81	50.00	17.19	L1	gnd

# TA Technology (Shanghai) Co., Ltd. Test Report

Report No.: RZA1202-0233RF01R2

Page 98of 109

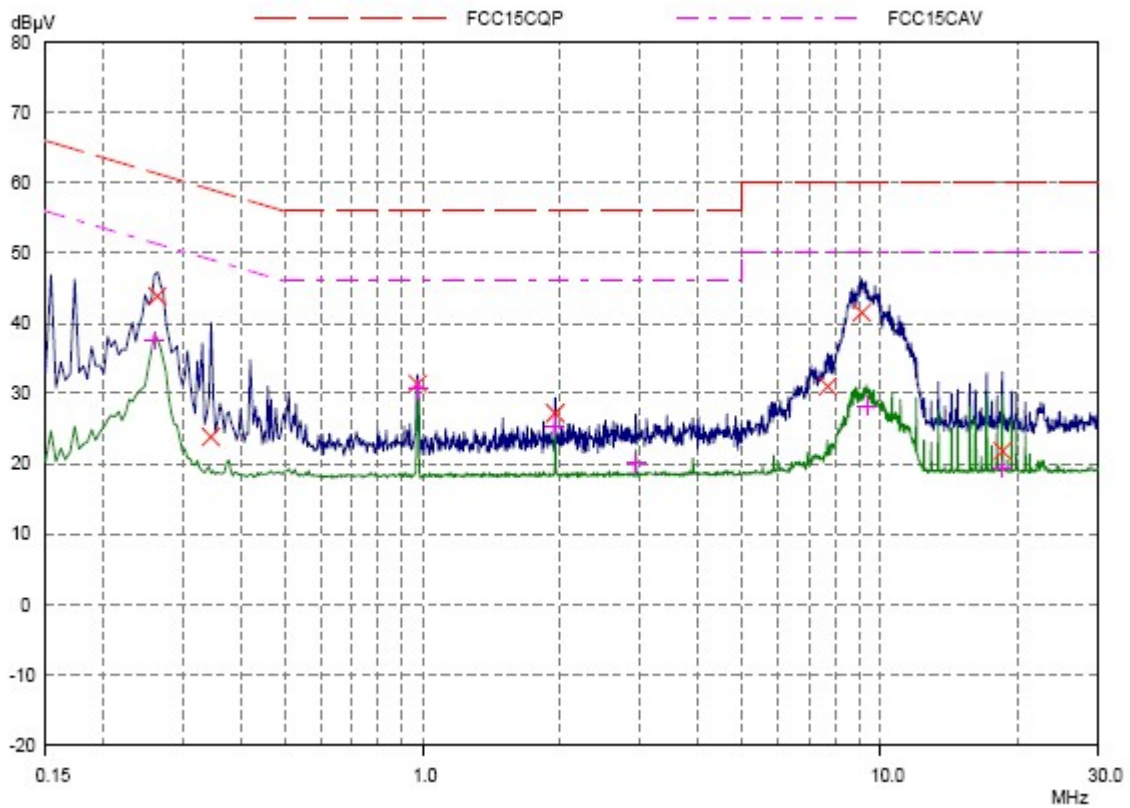

## N Line

### Final Measurement Results

Frequency MHz	QP Level dBµV	QP Limit dBµV	QP Delta dB	Phase -	PE -
0.26328	43.86	61.33	17.47	N	gnd
0.34531	23.80	59.07	35.27	N	gnd
0.97421	31.38	56.00	24.62	N	gnd
1.95078	27.18	56.00	28.82	N	gnd
7.67734	31.00	60.00	29.00	N	gnd
9.12656	41.52	60.00	18.48	N	gnd
18.46203	21.82	60.00	38.18	N	gnd

Frequency MHz	AV Level dBµV	AV Limit dBµV	AV Delta dB	Phase -	PE -
0.25937	37.58	51.45	13.87	N	gnd
0.97421	30.62	46.00	15.38	N	gnd
1.95078	25.39	46.00	20.61	N	gnd
2.92734	20.10	46.00	25.90	N	gnd
9.34921	28.26	50.00	21.74	N	gnd
18.46203	19.30	50.00	30.70	N	gnd

# TA Technology (Shanghai) Co., Ltd. Test Report

Report No.: RZA1202-0233RF01R2

Page 99of 109

802.11n HT20 CH11

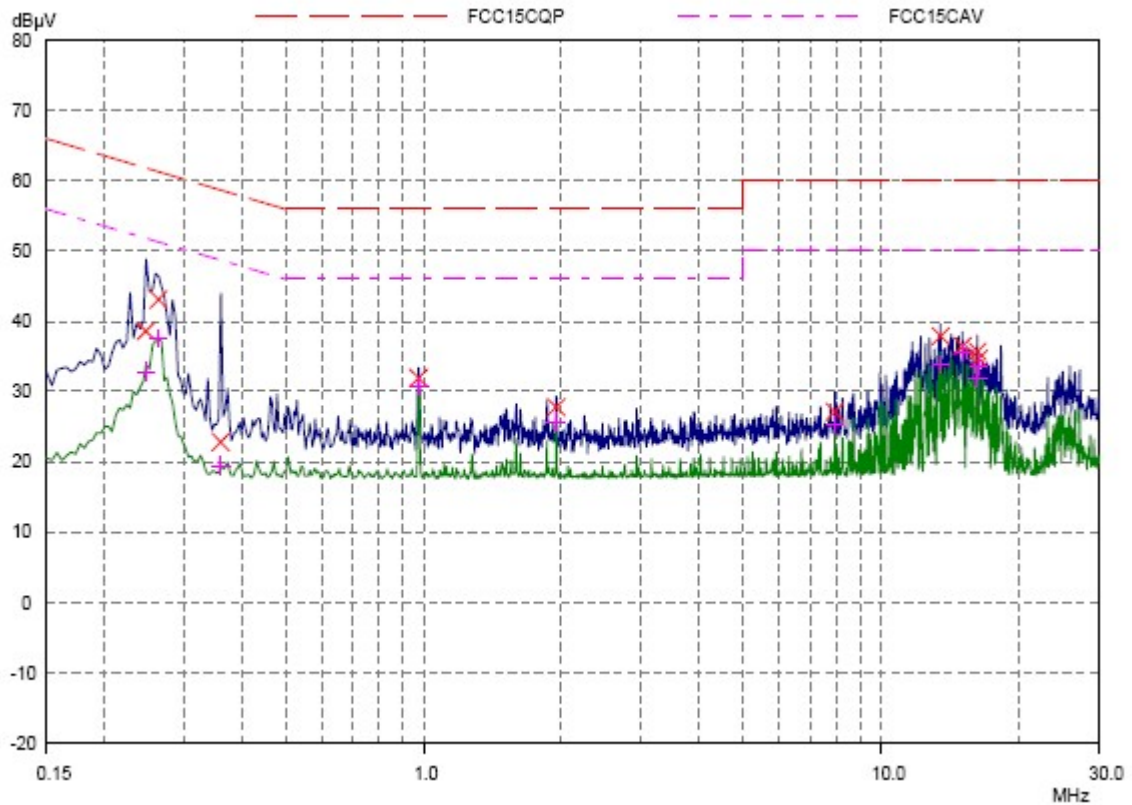

### L Line

#### Final Measurement Results

Frequency MHz	QP Level dBµV	QP Limit dBµV	QP Delta dB	Phase -	PE -
0.24765	38.58	61.84	23.28	L1	gnd
0.26328	43.10	61.33	18.23	L1	gnd
0.36093	22.80	58.71	35.91	L1	gnd
0.97421	31.90	56.00	24.10	L1	gnd
1.95078	27.80	56.00	28.20	L1	gnd
7.92343	27.10	60.00	32.90	L1	gnd
13.48203	37.88	60.00	22.14	L1	gnd
15.05625	36.46	60.00	23.54	L1	gnd
16.23203	35.68	60.00	24.32	L1	gnd
16.33359	34.64	60.00	25.36	L1	gnd

Frequency MHz	AV Level dBµV	AV Limit dBµV	AV Delta dB	Phase -	PE -
0.24765	32.74	51.84	19.10	L1	gnd
0.26328	37.51	51.33	13.82	L1	gnd
0.36093	19.45	48.71	29.26	L1	gnd
0.97421	30.71	46.00	15.29	L1	gnd
1.95078	25.69	46.00	20.31	L1	gnd
7.92343	25.24	50.00	24.76	L1	gnd
13.48203	33.89	50.00	16.11	L1	gnd
15.05625	35.59	50.00	14.41	L1	gnd
16.23203	31.93	50.00	18.07	L1	gnd
16.33359	33.72	50.00	16.28	L1	gnd

# TA Technology (Shanghai) Co., Ltd. Test Report

Report No.: RZA1202-0233RF01R2

Page 100 of 109

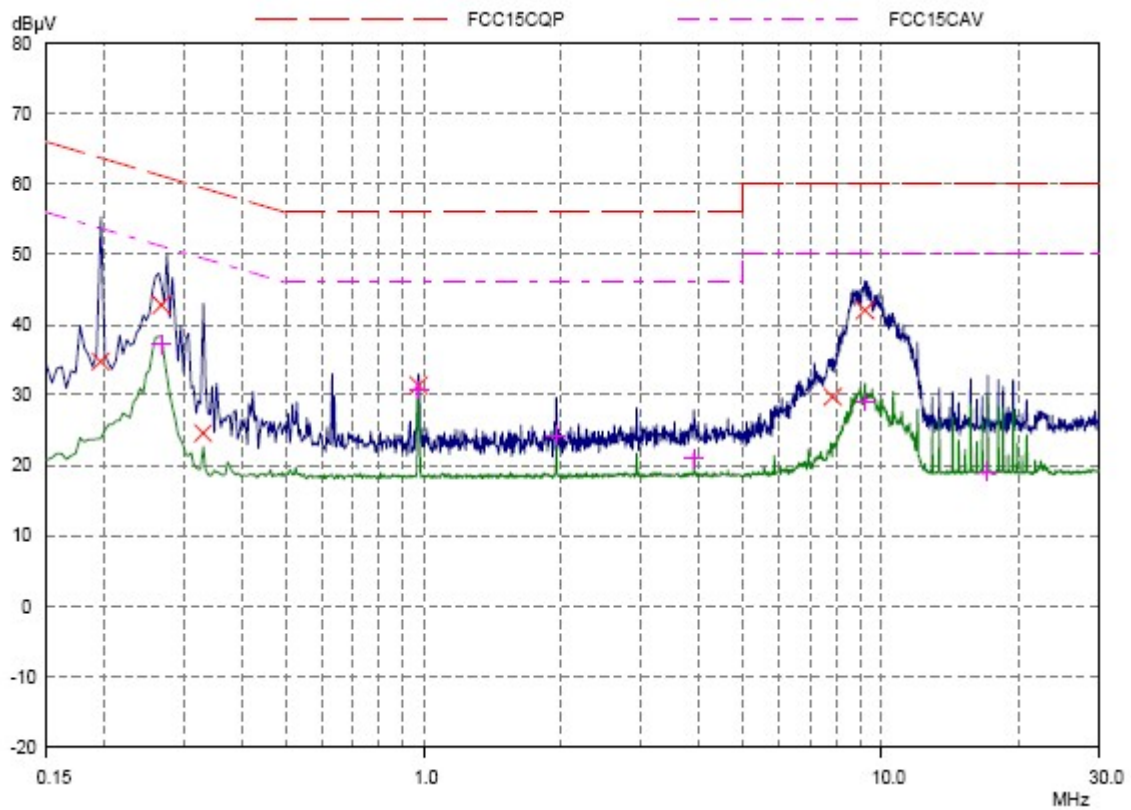

### N Line

#### Final Measurement Results

Frequency MHz	QP Level dBuV	QP Limit dBuV	QP Delta dB	Phase -	PE -
0.19887	34.74	63.74	29.00	N	gnd
0.26718	42.80	61.21	18.41	N	gnd
0.32968	24.52	59.46	34.94	N	gnd
0.97421	31.34	56.00	24.66	N	gnd
7.82578	29.72	60.00	30.28	N	gnd
9.23203	42.02	60.00	17.98	N	gnd

Frequency MHz	AV Level dBuV	AV Limit dBuV	AV Delta dB	Phase -	PE -
0.26718	37.20	51.21	14.01	N	gnd
0.97421	30.71	46.00	15.29	N	gnd
1.94887	24.27	46.00	21.73	N	gnd
3.9	20.89	46.00	25.11	N	gnd
9.22812	29.04	50.00	20.96	N	gnd
17.11093	19.14	50.00	30.86	N	gnd

# TA Technology (Shanghai) Co., Ltd. Test Report

Report No.: RZA1202-0233RF01R2

Page 101 of 109

802.11n HT40 CH3

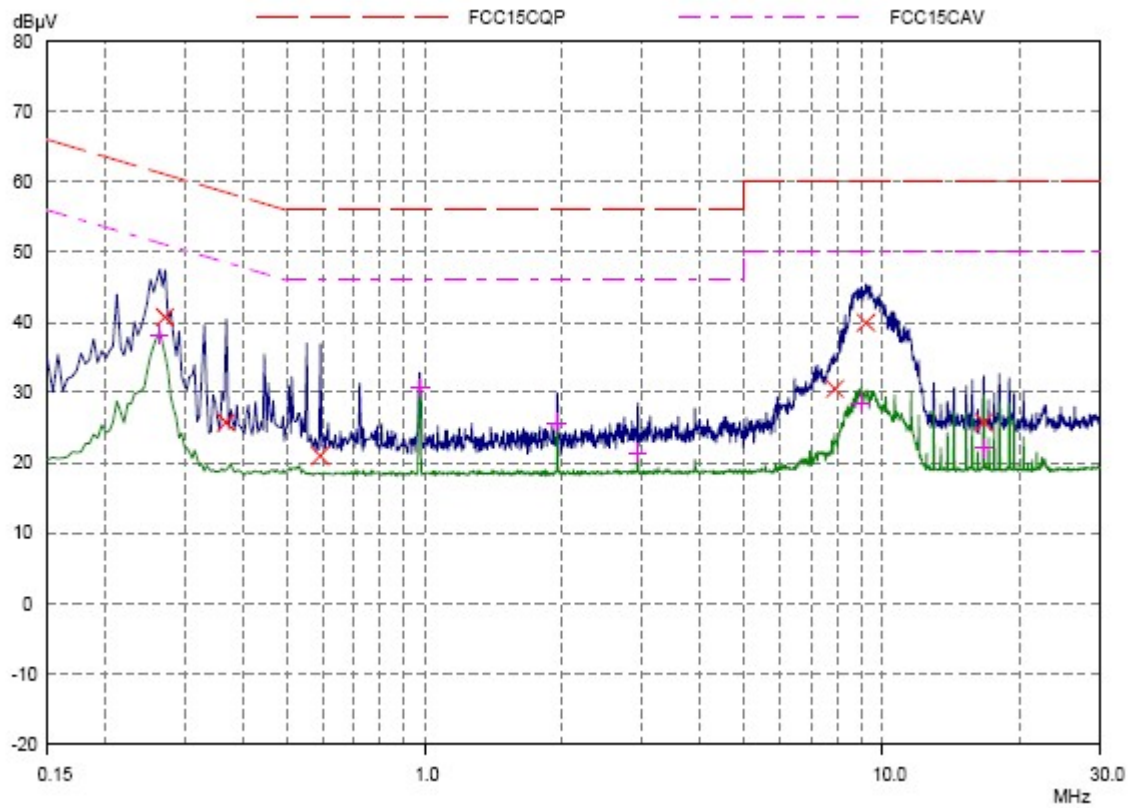

L Line

**Final Measurement Results**

Frequency MHz	QP Level dBµV	QP Limit dBµV	QP Delta dB	Phase	PE
0.27109	40.74	61.08	20.34	L1	gnd
0.36875	25.70	58.53	32.83	L1	gnd
0.5914	20.98	56.00	35.02	L1	gnd
7.87265	30.52	60.00	29.48	L1	gnd
9.2164	39.92	60.00	20.08	L1	gnd
16.67343	25.70	60.00	34.30	L1	gnd

  

Frequency MHz	AV Level dBµV	AV Limit dBµV	AV Delta dB	Phase	PE
0.26328	38.16	51.33	13.17	L1	gnd
0.97421	30.71	46.00	15.29	L1	gnd
1.95078	25.62	46.00	20.38	L1	gnd
2.92343	21.39	46.00	24.61	L1	gnd
9.00546	28.53	50.00	21.47	L1	gnd
16.67343	22.08	50.00	27.92	L1	gnd

# TA Technology (Shanghai) Co., Ltd. Test Report

Report No.: RZA1202-0233RF01R2

Page 102 of 109

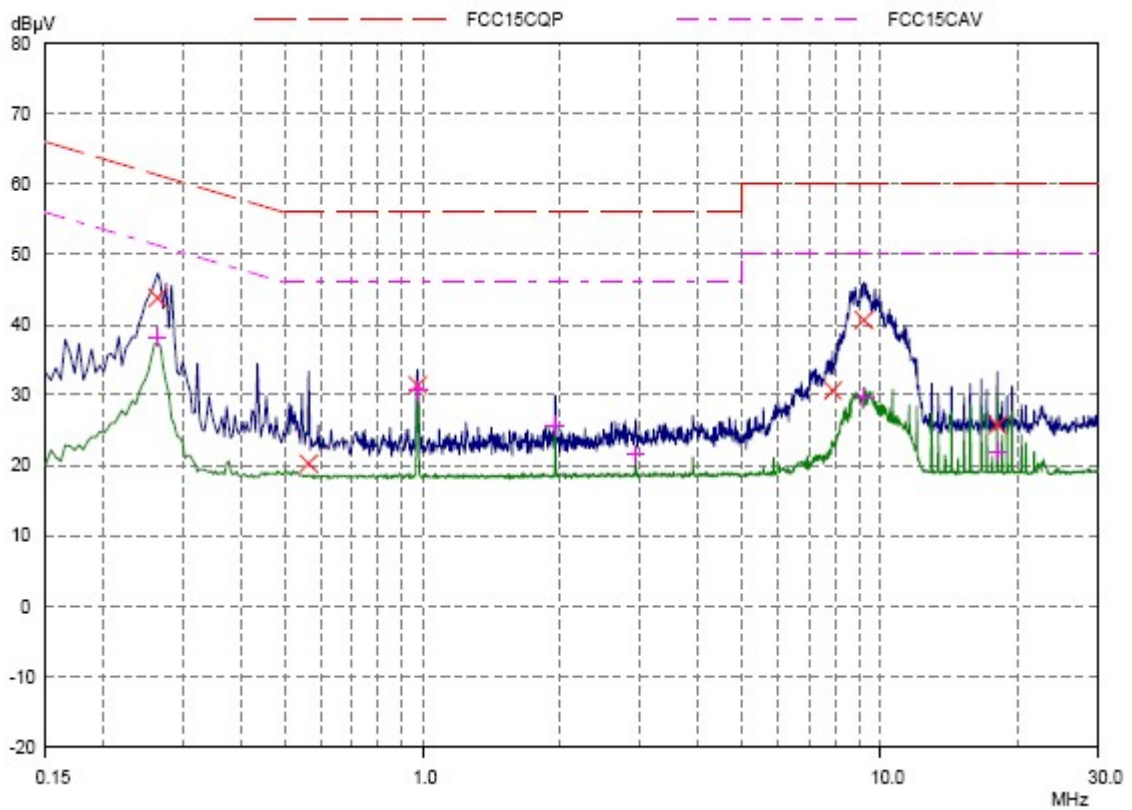

### N Line

#### Final Measurement Results

Frequency MHz	QP Level dBµV	QP Limit dBµV	QP Delta dB	Phase -	PE -
0.26328	43.80	61.33	17.53	N	gnd
0.56408	20.24	58.00	35.76	N	gnd
0.97421	31.38	58.00	24.64	N	gnd
7.88437	30.62	60.00	29.38	N	gnd
9.23593	40.64	60.00	19.36	N	gnd
18.04843	25.70	60.00	34.30	N	gnd

Frequency MHz	AV Level dBµV	AV Limit dBµV	AV Delta dB	Phase -	PE -
0.26328	38.16	51.33	13.17	N	gnd
0.97421	30.62	48.00	15.38	N	gnd
1.95078	25.69	48.00	20.31	N	gnd
2.92343	21.45	48.00	24.55	N	gnd
9.25548	29.66	50.00	20.34	N	gnd
18.04843	21.97	50.00	28.03	N	gnd

# TA Technology (Shanghai) Co., Ltd. Test Report

Report No.: RZA1202-0233RF01R2

Page 103 of 109

802.11n HT40 CH6

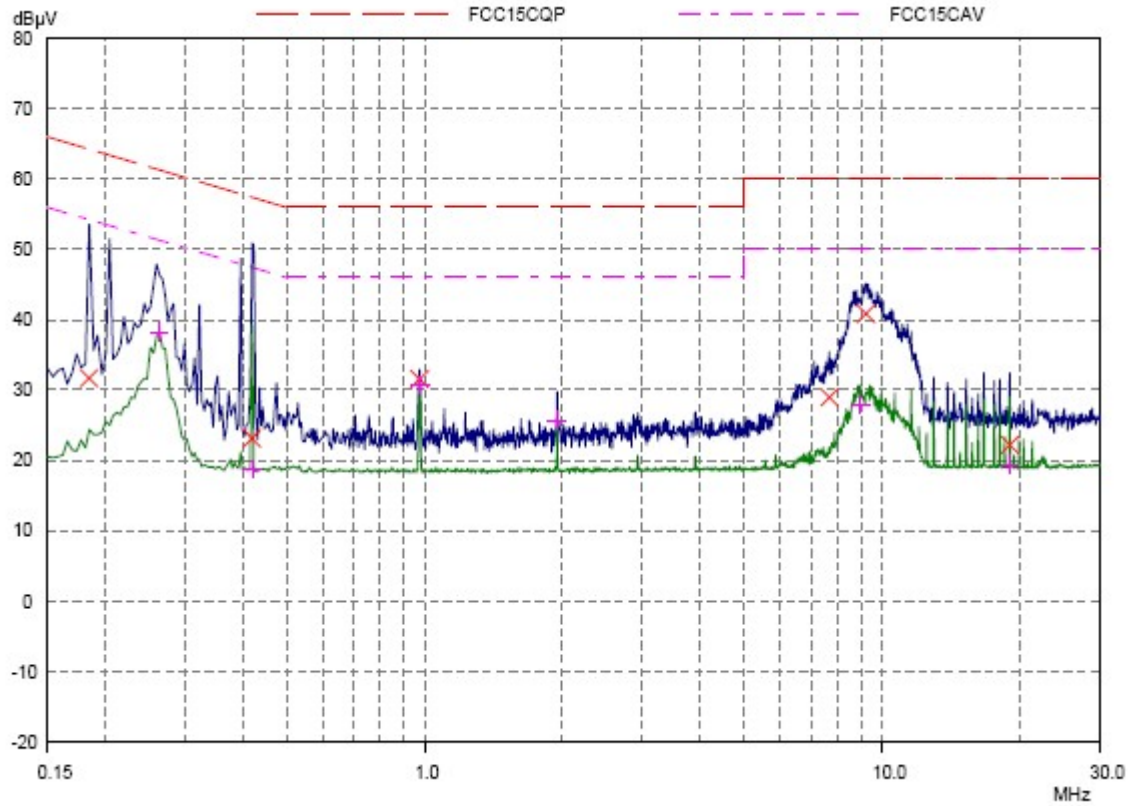

### L Line

#### Final Measurement Results

Frequency MHz	QP Level dBµV	QP Limit dBµV	QP Delta dB	Phase -	PE -
0.18515	31.66	64.25	32.59	L1	gnd
0.41953	23.10	57.46	34.36	L1	gnd
0.97421	31.52	56.00	24.48	L1	gnd
7.65781	28.96	60.00	31.04	L1	gnd
9.2164	40.84	60.00	19.16	L1	gnd
19.00546	22.22	60.00	37.78	L1	gnd

Frequency MHz	AV Level dBµV	AV Limit dBµV	AV Delta dB	Phase -	PE -
0.26328	38.23	51.33	13.10	L1	gnd
0.41953	18.75	47.46	28.71	L1	gnd
0.97421	30.71	46.00	15.29	L1	gnd
1.04687	25.89	46.00	20.31	L1	gnd
8.97421	27.99	50.00	22.01	L1	gnd
19.00546	19.45	50.00	30.55	L1	gnd

# TA Technology (Shanghai) Co., Ltd. Test Report

Report No.: RZA1202-0233RF01R2

Page 104 of 109

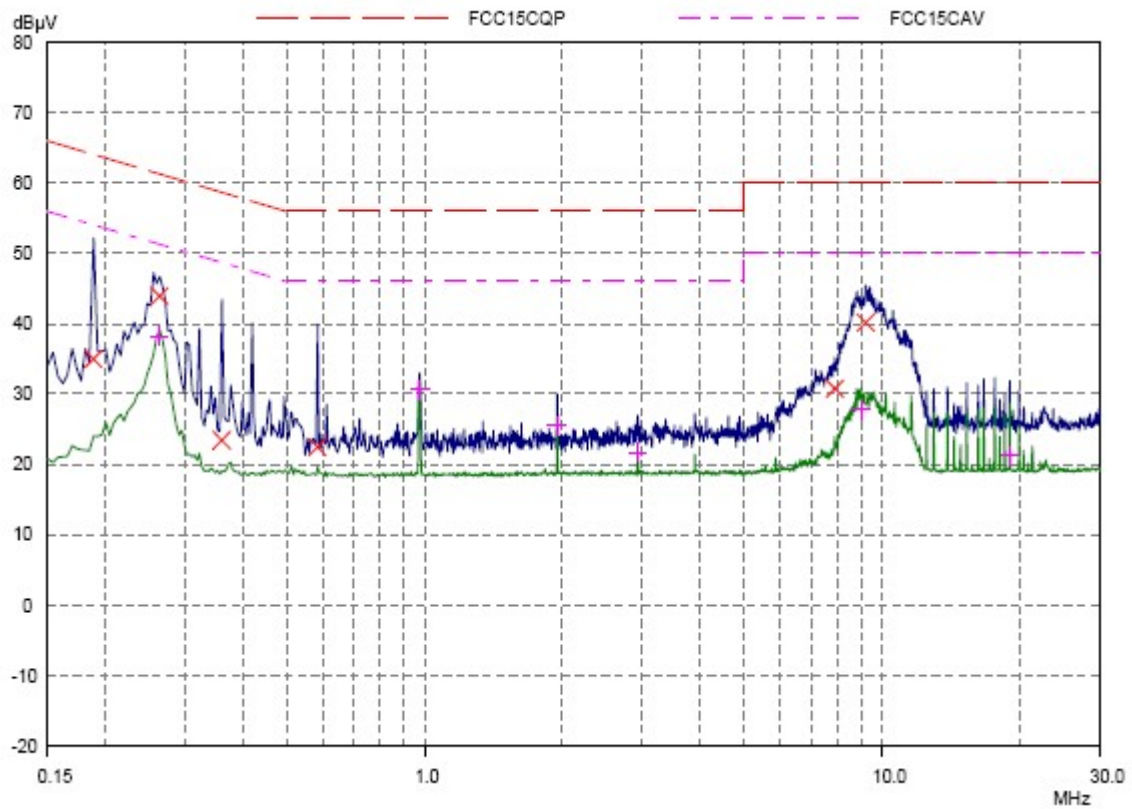

### N Line

#### Final Measurement Results

Frequency MHz	QP Level dBµV	QP Limit dBµV	QP Delta dB	Phase -	PE -
0.18908	34.98	64.08	29.12	N	gnd
0.26328	43.92	61.33	17.41	N	gnd
0.36093	23.42	58.71	35.29	N	gnd
0.58359	22.42	56.00	33.58	N	gnd
7.88046	30.72	60.00	29.28	N	gnd
9.2125	40.18	60.00	19.82	N	gnd

Frequency MHz	AV Level dBµV	AV Limit dBµV	AV Delta dB	Phase -	PE -
0.26328	38.16	51.33	13.17	N	gnd
0.97421	30.62	46.00	15.38	N	gnd
1.95078	25.54	46.00	20.46	N	gnd
2.92343	21.68	46.00	24.32	N	gnd
8.98984	27.70	50.00	22.30	N	gnd
19.01718	21.21	50.00	28.79	N	gnd



# TA Technology (Shanghai) Co., Ltd. Test Report

Report No.: RZA1202-0233RF01R2

Page 105 of 109

802.11n HT40 CH9

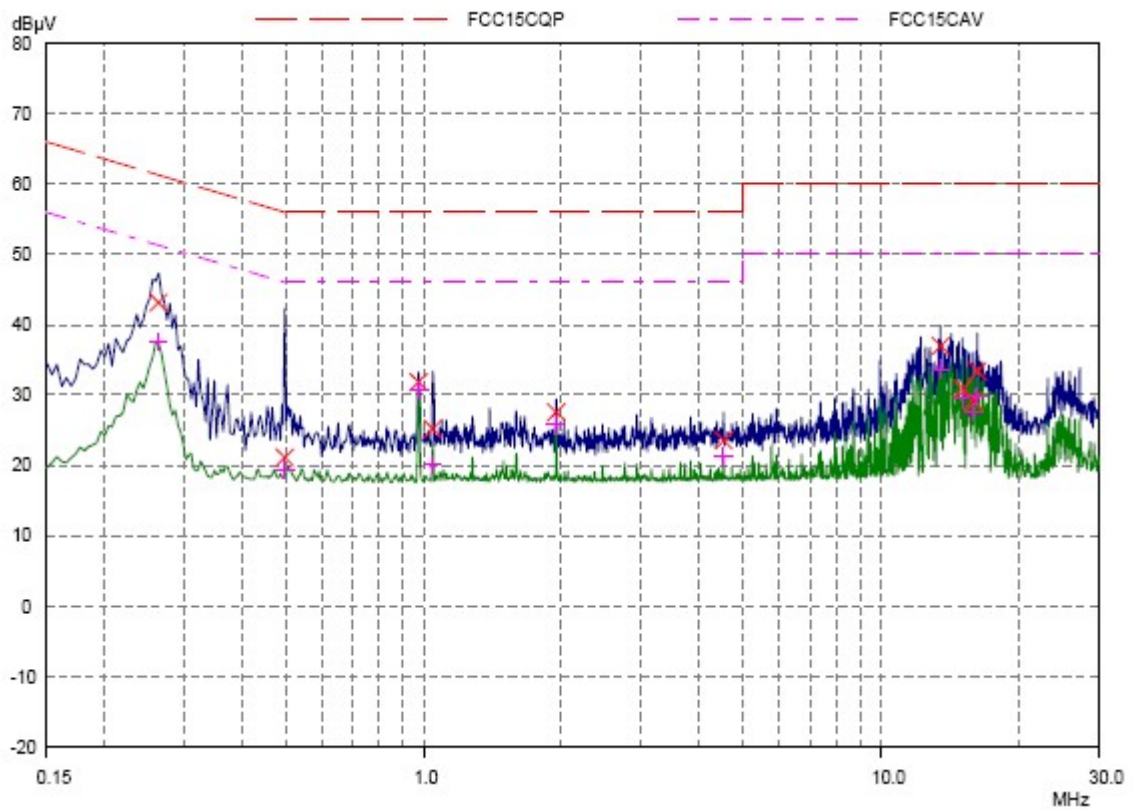

### L Line

#### Final Measurement Results

Frequency MHz	QP Level dBµV	QP Limit dBµV	QP Delta dB	Phase	PE
0.26328	43.16	61.33	18.17	L1	gnd
0.49765	21.12	56.04	34.92	L1	gnd
0.97421	31.86	56.00	24.14	L1	gnd
1.04843	25.20	56.00	30.80	L1	gnd
1.95078	27.52	56.00	28.48	L1	gnd
4.525	23.52	56.00	32.48	L1	gnd
13.47812	36.96	60.00	23.04	L1	gnd
15.05625	30.90	60.00	29.10	L1	gnd
15.93906	29.14	60.00	30.86	L1	gnd
16.23203	33.36	60.00	26.64	L1	gnd

  

Frequency MHz	AV Level dBµV	AV Limit dBµV	AV Delta dB	Phase	PE
0.26328	37.51	51.33	13.82	L1	gnd
0.49765	19.45	46.04	26.59	L1	gnd
0.97421	30.71	46.00	15.29	L1	gnd
1.04843	20.17	46.00	25.83	L1	gnd
1.95078	25.76	46.00	20.24	L1	gnd
4.525	21.21	46.00	24.79	L1	gnd
13.47812	33.72	50.00	16.28	L1	gnd
15.05625	29.52	50.00	20.48	L1	gnd
15.93906	27.59	50.00	22.41	L1	gnd
16.23203	29.76	50.00	20.24	L1	gnd

# TA Technology (Shanghai) Co., Ltd. Test Report

Report No.: RZA1202-0233RF01R2

Page 106 of 109

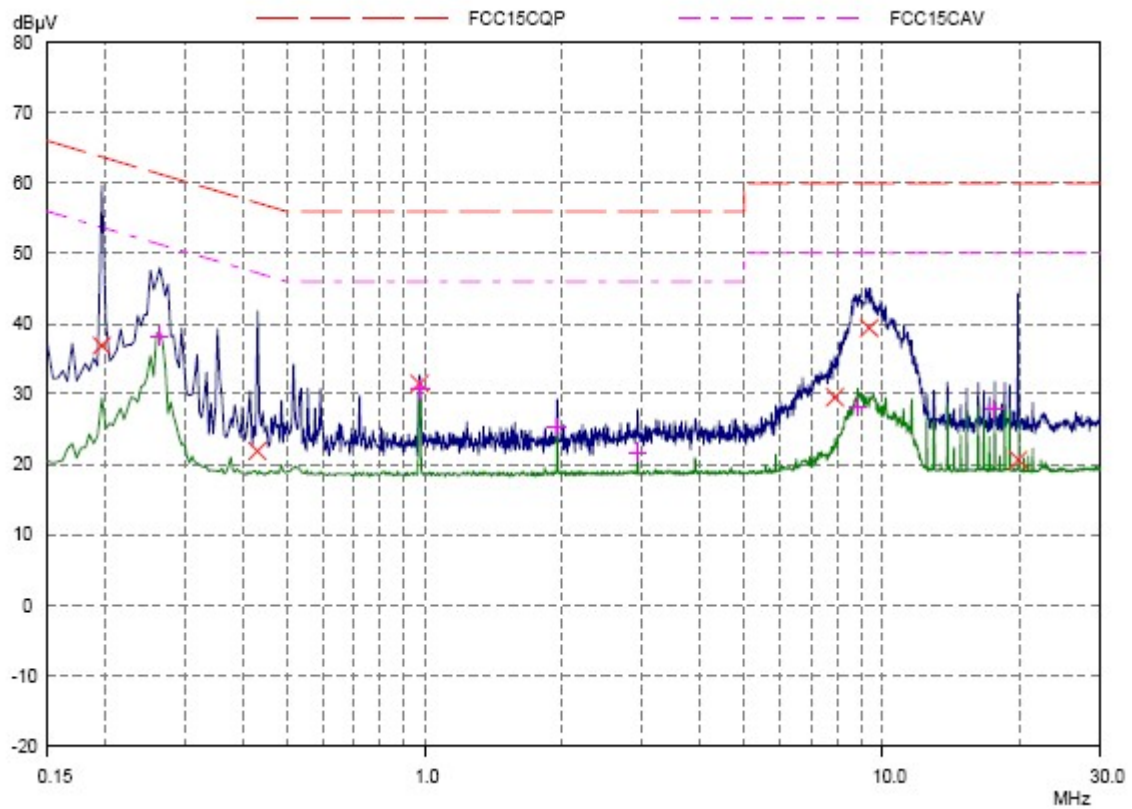

## N Line

### Final Measurement Results

Frequency MHz	QP Level dBµV	QP Limit dBµV	QP Delta dB	Phase -	PE -
0.19687	36.88	63.74	26.86	N	gnd
0.43125	21.88	57.23	35.35	N	gnd
0.97421	31.46	56.00	24.54	N	gnd
7.86675	29.52	60.00	30.48	N	gnd
9.39218	39.34	60.00	20.66	N	gnd
19.81796	20.62	60.00	39.38	N	gnd

Frequency MHz	AV Level dBµV	AV Limit dBµV	AV Delta dB	Phase -	PE -
0.26328	38.23	51.33	13.10	N	gnd
0.97421	30.62	46.00	15.38	N	gnd
1.95078	25.24	46.00	20.76	N	gnd
2.92343	21.68	46.00	24.32	N	gnd
8.85703	28.10	50.00	21.90	N	gnd
17.83046	27.70	50.00	22.30	N	gnd

**TA Technology (Shanghai) Co., Ltd.**  
**Test Report**

Report No.: RZA1202-0233RF01R2

Page 107 of 109

### 3. Main Test Instruments

No.	Name	Type	Manufacturer	Serial Number	Calibration Date	Valid Period
01	Peak Power Analyzer	8990B	Agilent	51000109	2011-06-01	One year
02	Wideband Power Sensors	N1923A	Agilent	MY51220004	2011-06-01	One year
03	EMI Test Receiver	ESCI	R&S	100948	2011-06-30	One year
04	TRILOG Broadband Antenna	VULB 9163	Schwarzbeck	391	2011-05-14	Two years
05	Double Ridged Waveguide Horn Antenna	HF907	R&S	100126	2011-07-01	Two years
06	PSG Analog Signal Generator	E8257D	Agilent	MY49281101	2011-06-29	One year
07	ESG Vector Signal Generator	E4438C	Agilent	MY49070900	2011-07-01	One year
08	Spectrum Analyzer	E4445A	Agilent	MY46181146	2011-06-07	One year
09	Power Splitter	SHX-GF2-2-13	Hua Xiang	10120101	NA	NA
10	MOB COMMS DC SUPPLY	66319D	Agilent	MY43004105	2011-06-30	One year
11	Power Sensor	E9304A	Agilent	MY50220022	2011-06-01	One year
12	Power Meter	E4418B	Agilent	MY50000623	2011-06-07	One year
13	Vibration table	ESS-050-120	dongling	D1007126	2010-08-23	Three years
14	Universal Radio Communication Tester	E5515C	Agilent	MY48367192	2011-06-04	One year

\*\*\*\*\*END OF REPORT \*\*\*\*\*

## ANNEX A: EUT Appearance and Test Setup

### A.1 EUT Appearance

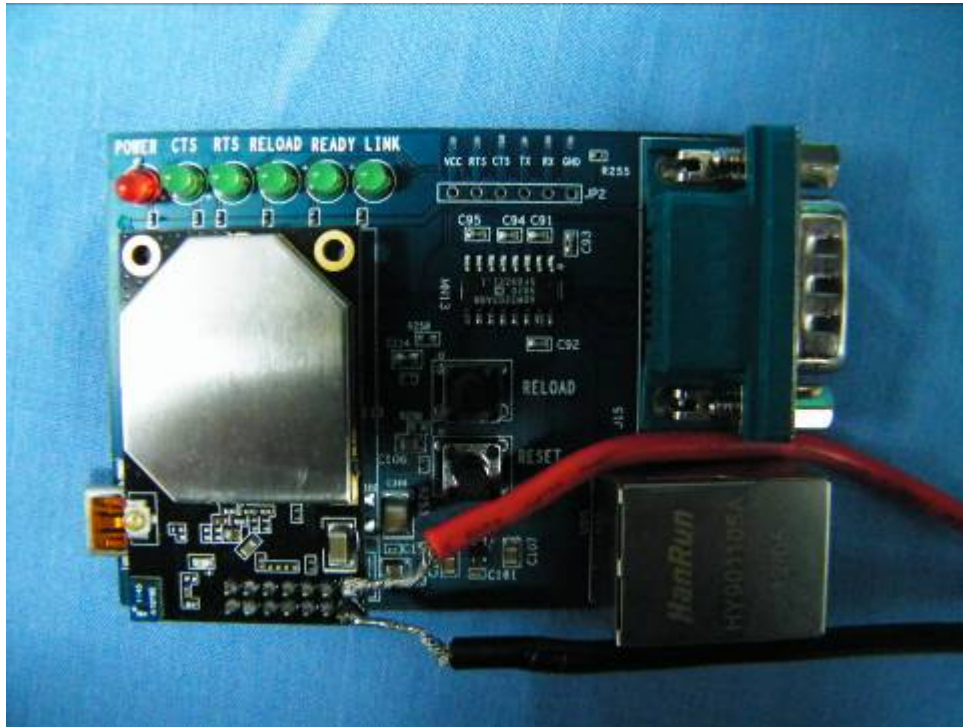

Picture 1 Constituents of EUT

## A.2 Test Setup



Picture 2 Radiated Emission Test Setup



Picture 3 Conducted Emission Test Setup