

FCC TEST REPORT
for
High-Flying Electronics Technology Co., Ltd
Embedded Wi-Fi Module
Model No.: HF-LPT100

Prepared for : High-Flying Electronics Technology Co., Ltd
Address : Room 511, #7Building, No.365 Chuanhong Road, Pudong,
Shanghai, China

Prepared By : Shenzhen Anbotek Compliance Laboratory Limited
Address : 1/F., Building 1, SEC Industrial Park, No.0409 Qianhai Road,
Nanshan District, Shenzhen, Guangdong, China
Tel: (86) 755-26066544
Fax: (86) 755-26014772

Report Number : 201311815F
Date of Test : Nov. 18~ Dec. 10, 2013
Date of Report : Dec. 10, 2013

TABLE OF CONTENT

Description

Page

Test Report

1. GENERAL INFORMATION	4
1.1. Description of Device (EUT).....	4
1.2. Auxiliary Equipment Used during Test.....	5
1.3. Description of Test Facility	5
1.4. Measurement Uncertainty.....	5
2. TEST METHODOLOGY	6
2.1. Summary of Test Results.....	6
2.2. Description of Test Modes.....	6
2.3. List of channels:.....	7
3. CONDUCTED EMISSION TEST.....	8
3.1. Block Diagram of Test Setup	8
3.2. Power Line Conducted Emission Measurement Limits (15.207).....	8
3.3. Configuration of EUT on Measurement	8
3.4. Operating Condition of EUT	8
3.5. Test Procedure	9
3.6. Test equipment	9
3.7. Power Line Conducted Emission Measurement Results	9
4. FCC PART 15.247 REQUIREMENTS FOR DSSS & OFDM MODULATION.....	12
4.1 Test Setup	12
4.2 6dB Bandwidth	12
4.3. Maximum Peak output power test	20
4.4. Band Edges Measurement	28
4.5. Peak Power Spectral Density	41
4.6. Radiated Emissions.....	49
5. PHOTOGRAPH.....	60
5.1. Photo of Conducted Emission Measurement.....	60
5.2. Photo of Radiation Emission Test	60

Appendix I (2 Pages)

Appendix II (1 Page)

TEST REPORT

Applicant : High-Flying Electronics Technology Co., Ltd
Manufacturer : High-Flying Electronics Technology Co., Ltd
EUT : Embedded Wi-Fi Module
Model No. : HF-LPT100
Serial No. : N/A
Trade Mark : High-Flying
Rating : DC 3.1V-3.6V, 240mA

Measurement Procedure Used:
FCC Part15 Subpart C, Paragraph 15.247

The device described above is tested by Shenzhen Anbotek Compliance Laboratory Limited to determine the maximum emission levels emanating from the device and the severe levels of the device can endure and its performance criterion. The measurement results are contained in this test report and Shenzhen Anbotek Compliance Laboratory Limited is assumed full of responsibility for the accuracy and completeness of these measurements. Also, this report shows that the EUT (Equipment Under Test) is technically compliant with the FCC Part 15 Subpart C requirements.

This report applies to above tested sample only and shall not be reproduced in part without written approval of Shenzhen Anbotek Compliance Laboratory Limited.

Date of Test : Nov. 18~ Dec. 10, 2013

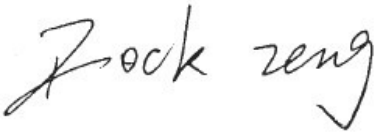
Prepared by : 
(Tested Engineer / Rock Zeng)

Reviewer : 
(Project Manager / Sally Zhang)

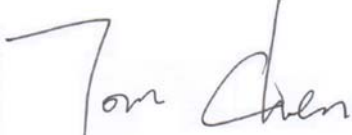
Approved & Authorized Signer : 
(Manager / Tom Chen)

1. GENERAL INFORMATION

1.1. Description of Device (EUT)

EUT	: Embedded Wi-Fi Module
Model Number	: HF-LPT100
Test Power Supply	: AC 120V/60Hz for adapter
RF Transmission Frequency	: 2412MHz~2462MHz (802.11b/802.11g/802.11n(HT20)) 2422MHz~2452MHz (802.11n(HT40))
Channels	: 11 For (802.11b/802.11g/802.11n(HT20)) 7 For (802.11n(HT40))
Modulation	802.11b CCK 802.11g OFDM 802.11n MCS
Antenna Specification	: Type: External Antenna Model: EDA-1513-25GR2-B2 Brand: MAG LAYERS Gain: 2.0dBi
Applicant Address	: High-Flying Electronics Technology Co., Ltd Room 511, #7Building, No.365 Chuanhong Road, Pudong, Shanghai, China
Manufacturer Address	: High-Flying Electronics Technology Co., Ltd Room 511, #7Building, No.365 Chuanhong Road, Pudong, Shanghai, China
Factory Address	: Shanghai Quick Turn Electronic Co., Ltd. 4F, Bldg. 1, No. 1069 Chuansha Road, Pudong New District, Shanghai, China
Date of receiver	: Nov. 18, 2013
Date of Test	: Nov. 18~ Dec. 10, 2013

1.2. Auxiliary Equipment Used during Test

N/A

1.3. Description of Test Facility

The test facility is recognized, certified, or accredited by the following organizations:

CNAS - LAB Code: L3503

Shenzhen Anbotek Compliance Laboratory Limited., Laboratory has been assessed and in compliance with CNAS/CL01: 2006 accreditation criteria for testing laboratories (identical to ISO/IEC 17025:2005 General Requirements) for the Competence of Testing Laboratories.

FCC-Registration No.: 752021

Shenzhen Anbotek Compliance Laboratory Limited, EMC Laboratory has been registered and fully described in a report filed with the (FCC) Federal Communications Commission. The acceptance letter from the FCC is maintained in our files. Registration 752021, July 10, 2013.

IC-Registration No.: 8058A-1

Shenzhen Anbotek Compliance Laboratory Limited., EMC Laboratory has been registered and fully described in a report filed with the (IC) Industry Canada. The acceptance letter from the IC is maintained in our files. Registration 8058A, February 22, 2013.

Test Location

All Emissions tests were performed at
Shenzhen Anbotek Compliance Laboratory Limited. at 1/F., Building 1, SEC Industrial Park, No.0409 Qianhai Road, Nanshan District, Shenzhen, Guangdong, China

1.4. Measurement Uncertainty

Radiation Uncertainty	:	Ur = 4.3dB
Conduction Uncertainty	:	Uc = 3.4dB

2. TEST METHODOLOGY

The tests documented in this report were performed in accordance with ANSI C63.4: 2009 and FCC Part 15, Paragraph 15.247.

2.1. Summary of Test Results

The EUT has been tested according to the following specifications:

Standard	Test Type	Result	Notes
FCC Part 15, Paragraph 15.107, 15.207	Conducted Emission Test	PASS	Complies
FCC Part 15, Paragraph 15.247(b)(1)	Peak Output Power	PASS	Complies
FCC Part 15, Paragraph 15.247(a)(2)	6dB Bandwidth	PASS	Complies
FCC Part 15, Paragraph 15.247(c)	100kHz Bandwidth of Frequency Band Edges	PASS	Complies
FCC Part 15, Paragraph 15.209(a)(f)	Spurious Emission	PASS	Complies
FCC Part 15, Paragraph 15.247(a)(1)	Frequency Separation	-	N/A
FCC Part 15, Paragraph 15.247(a)(1)(iii)	Number of Hopping Frequency	-	N/A
FCC Part 15, Paragraph 15.247(a)(1)(iii)	Time of Occupancy	-	N/A
FCC Part 15, Paragraph 15.247(c)	Peak Power Density	PASS	Complies

2.2. Description of Test Modes

The EUT has been tested under operating condition.

Software used to control the EUT for staying in continuous transmitting and receiving mode is programmed.

IEEE802.11b: Channel 1(2412MHz), Channel 6(2437MHz) and Channel 11(2462MHz) with 1 Mbps lowest data rate (worst case) are chosen for the final testing.

IEEE802.11g: Channel 1(2412MHz), Channel 6(2437MHz) and Channel 11(2462MHz) with 6 Mbps lowest data rate (the worst case) are chosen for the final testing.

IEEE802.11n (HT20): Channel 1(2412MHz), Channel 6(2437MHz) and Channel 11(2462MHz) with MCS 0 Mbps lowest data rate (the worst case) are chosen for the final testing.

IEEE802.11n (HT40): Channel 3(2422MHz), Channel 6(2437MHz) and Channel 9(2452MHz) with MCS 0 Mbps lowest data rate (the worst case) are chosen for the final testing.

2.3. List of channels:

√ - available

X - tested

Number	Frequency(MHz)		802.11 b/g/n (HT20)	802.11 b/g/n (HT40)
1	2412	√	X	
2	2417	√		
3	2422	√		X
4	2427	√		
5	2432	√		
6	2437	√	X	X
7	2442	√		
8	2447	√		
9	2452	√		X
10	2457	√		
11	2462	√	X	

3. Conducted Emission Test

3.1. Block Diagram of Test Setup

3.1.1. Block diagram of connection between the EUT and simulators

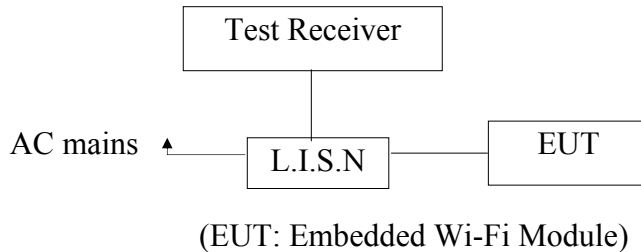

3.2. Power Line Conducted Emission Measurement Limits (15.207)

Frequency MHz	Limits dB(μV)	
	Quasi-peak Level	Average Level
0.15 ~ 0.50	66 ~ 56*	56 ~ 46*
0.50 ~ 5.00	56	46
5.00 ~ 30.00	60	50

- Notes: 1. *Decreasing linearly with logarithm of frequency.
2. The lower limit shall apply at the transition frequencies.

3.3. Configuration of EUT on Measurement

The following equipments are installed on Power Line Conducted Emission Measurement to meet the commission requirement and operating regulations in a manner which tends to maximize its emission characteristics in a normal application.

EUT : Embedded Wi-Fi Module
Model Number : HF-LPT100
Applicant : High-Flying Electronics Technology Co., Ltd

3.4. Operating Condition of EUT

- 3.4.1. Setup the EUT and simulator as shown as Section 3.1.
- 3.4.2. Turn on the power of all equipment.
- 3.4.3. Let the EUT work in test mode (On) and measure it.

3.5. Test Procedure

The EUT system is connected to the power mains through a line impedance stabilization network (L.I.S.N.). This provides a 50ohm coupling impedance for the EUT system. Please refer the block diagram of the test setup and photographs. Both sides of AC line are checked to find out the maximum conducted emission. In order to find the maximum emission levels, the relative positions of equipment and all of the interface cables shall be changed according to FCC ANSI C63.4-2003 on Conducted Emission Measurement.

The bandwidth of test receiver (ESCI) set at 9KHz.

The frequency range from 150KHz to 30MHz is checked.

The test results are reported on Section 3.6.

3.6. Test equipment

Item	Equipment	Manufacturer	Model No.	Serial No.	Last Cal.	Cal. Interval
1.	Two-Line V-network	Rohde & Schwarz	ENV216	100055	Apr. 23, 2013	1 Year
2.	EMI Test Receiver	Rohde & Schwarz	ESCI	100627	Apr. 23, 2013	1 Year
3.	RF Switching Unit	Compliance Direction	RSU-M2	38303	Apr. 23, 2013	1 Year

3.7. Power Line Conducted Emission Measurement Results

PASS.

The frequency range from 150KHz to 30 MHz is investigated.

Please refer the following pages.

CONDUCTED EMISSION TEST DATA

Test Site: 1# Shielded Room
 Operating Condition: On
 Operator: Bevan Zhang
 Test Specification: AC 120V/60Hz for adapter
 Comment: L
 Tem:25°C Hum:50%

SCAN TABLE: "Voltage (150K~30M) FIN"
 Short Description: 150K-30M Disturbance Voltages

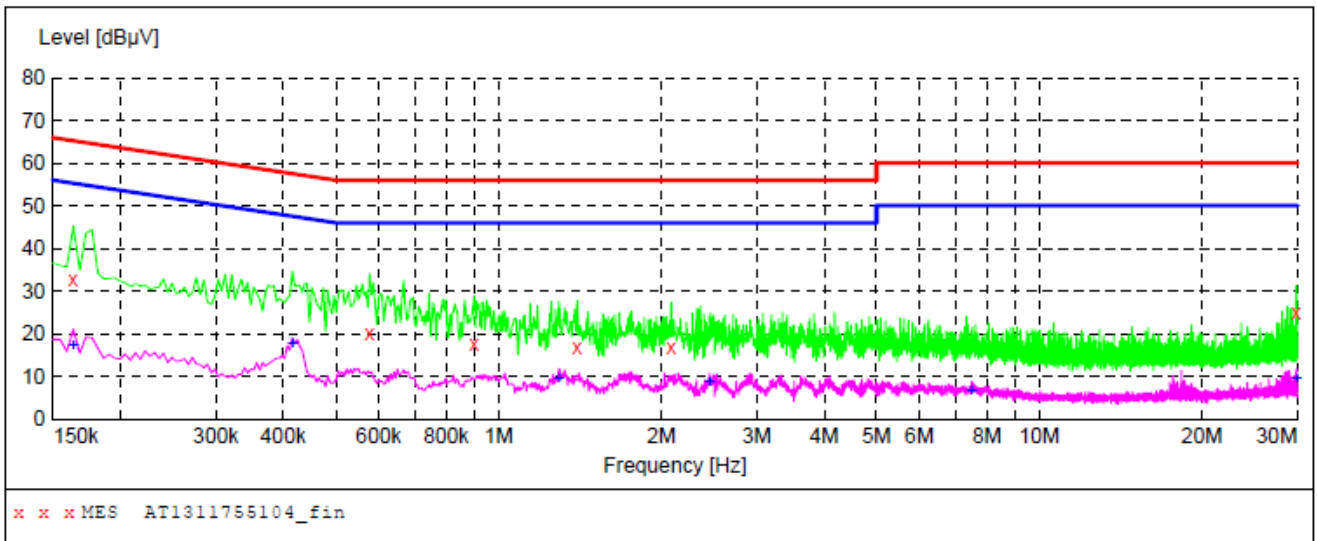

MEASUREMENT RESULT: "AT1311755104_fin"

11/25/2013 10:08AM

Frequency MHz	Level dBuV	Transd dB	Limit dBuV	Margin dB	Detector	Line	PE
0.163500	32.70	20.1	65	32.6	QP	L1	GND
0.577500	20.00	20.1	56	36.0	QP	L1	GND
0.901500	17.70	20.1	56	38.3	QP	L1	GND
1.396000	16.90	20.2	56	39.1	QP	L1	GND
2.084500	16.80	20.3	56	39.2	QP	L1	GND
29.840500	24.90	20.9	60	35.1	QP	L1	GND

MEASUREMENT RESULT: "AT1311755104_fin2"

11/25/2013 10:08AM

Frequency MHz	Level dBuV	Transd dB	Limit dBuV	Margin dB	Detector	Line	PE
0.163500	17.20	20.1	55	38.1	AV	L1	GND
0.415500	17.80	20.1	48	29.7	AV	L1	GND
1.292500	9.30	20.2	46	36.7	AV	L1	GND
2.453500	8.70	20.3	46	37.3	AV	L1	GND
7.502500	6.80	20.5	50	43.2	AV	L1	GND
29.899000	9.30	20.9	50	40.7	AV	L1	GND

CONDUCTED EMISSION TEST DATA

Test Site: 1# Shielded Room
 Operating Condition: On
 Operator: Bevan Zhang
 Test Specification: AC 120V/60Hz for adapter
 Comment: N
 Tem:25°C Hum:50%

SCAN TABLE: "Voltage (150K~30M) FIN"

Short Description: 150K-30M Disturbance Voltages

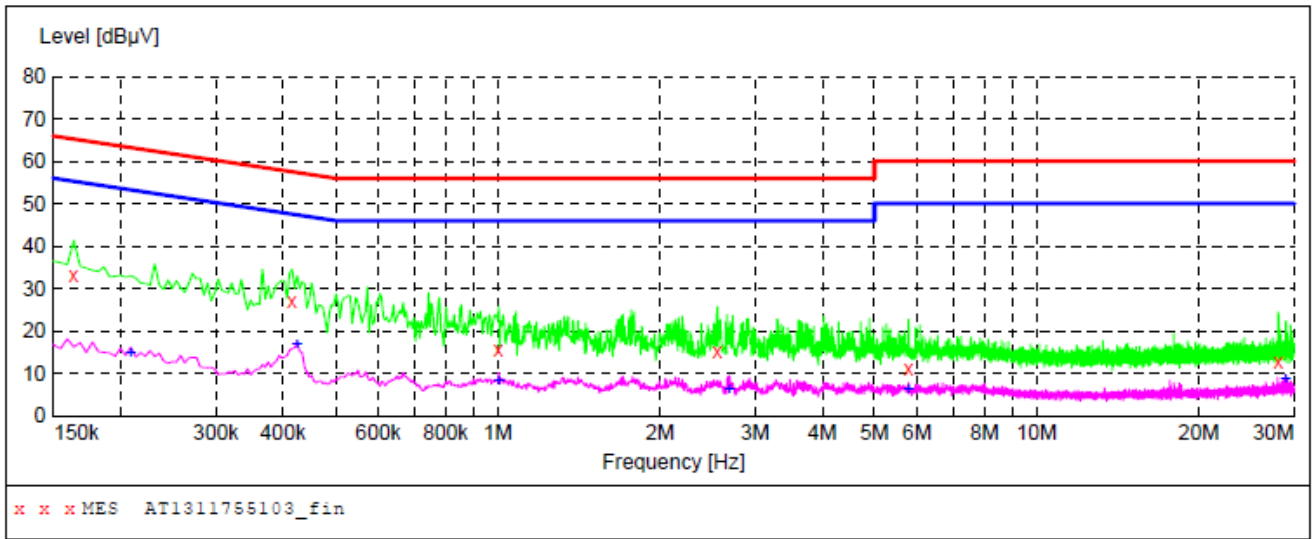

MEASUREMENT RESULT: "AT1311755103_fin"

11/25/2013 10:05AM

Frequency MHz	Level dBuV	Transd dB	Limit dBuV	Margin dB	Detector	Line	PE
0.163500	33.00	20.1	65	32.3	QP	N	GND
0.415500	27.20	20.1	58	30.3	QP	N	GND
1.004500	15.50	20.2	56	40.5	QP	N	GND
2.557000	15.00	20.4	56	41.0	QP	N	GND
5.783500	11.10	20.5	60	48.9	QP	N	GND
28.040500	12.80	20.9	60	47.2	QP	N	GND

MEASUREMENT RESULT: "AT1311755103_fin2"

11/25/2013 10:05AM

Frequency MHz	Level dBuV	Transd dB	Limit dBuV	Margin dB	Detector	Line	PE
0.208500	14.60	20.1	53	38.7	AV	N	GND
0.424500	16.90	20.1	47	30.5	AV	N	GND
1.004500	8.20	20.2	46	37.8	AV	N	GND
2.692000	6.00	20.4	46	40.0	AV	N	GND
5.783500	6.00	20.5	50	44.0	AV	N	GND
28.940500	8.60	20.9	50	41.4	AV	N	GND

4. FCC Part 15.247 Requirements for DSSS & OFDM Modulation

4.1 Test Setup

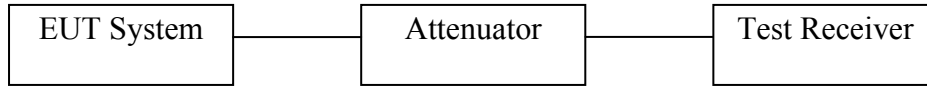

4.2 6dB Bandwidth

a. Limit

For the direct sequence systems, the minimum 6dB bandwidth shall be at least 500kHz.

b. Test Procedure

1. Place the EUT on the table and set it in the transmitting mode.
2. Remove the antenna from the EUT and then connect a low loss RF cable from the antenna port to the spectrum analyzer.
3. Set the spectrum analyzer as:
 RBW = 100kHz, VBW \geq 3*RBW = 300kHz,
 Detector= Peak
 Trace mode= Max hold.
 Sweep- auto couple.
4. Mark the peak frequency and -6dB (upper and lower) frequency.
5. Repeat until all the rest channels are investigated.

c. Test Setup See 4.1

d. Test Equipment

Item	Equipment	Manufacturer	Model No.	Serial No.	Last Cal.	Cal. Interval
1.	Spectrum Analysis	Agilent	E4407B	US39390582	Aug. 09, 2013	1 Year
2.	Preamplifier	Instruments corporation	EMC011830	980100	Aug. 09, 2013	1 Year
3.	EMI Test Receiver	Rohde & Schwarz	ESPI	101604	Apr. 23, 2013	1 Year
4.	Double Ridged Horn Antenna	Instruments corporation	GTH-0118	351600	Aug. 09, 2013	3 Year
5.	EMI Test Software EZ-EMC	SHURPLE	N/A	N/A	N/A	N/A

e. Test Results

Pass.

f. Test Data

Test mode: IEEE 802.11b

Channel	Frequency (MHz)	Bandwidth (MHz)	Limit (kHz)	Results
Low	2412	12.16		Pass
Mid	2437	12.16	>500	Pass
High	2462	12.16		Pass

Test mode: IEEE 802.11g

Channel	Frequency (MHz)	Bandwidth (MHz)	Limit (kHz)	Results
Low	2412	16.48		Pass
Mid	2437	16.48	>500	Pass
High	2462	16.48		Pass

Test mode: IEEE 802.11n (HT20)

Channel	Frequency (MHz)	Bandwidth (MHz)	Limit (kHz)	Results
Low	2412	17.60		Pass
Mid	2437	17.60	>500	Pass
High	2462	17.60		Pass

Test mode: IEEE 802.11n (HT40)

Channel	Frequency (MHz)	Bandwidth (MHz)	Limit (kHz)	Results
Low	2422	36.32		Pass
Mid	2437	36.32	>500	Pass
High	2452	36.32		Pass

Test Plots See the following page.

Test Mode: 802.11b---Low

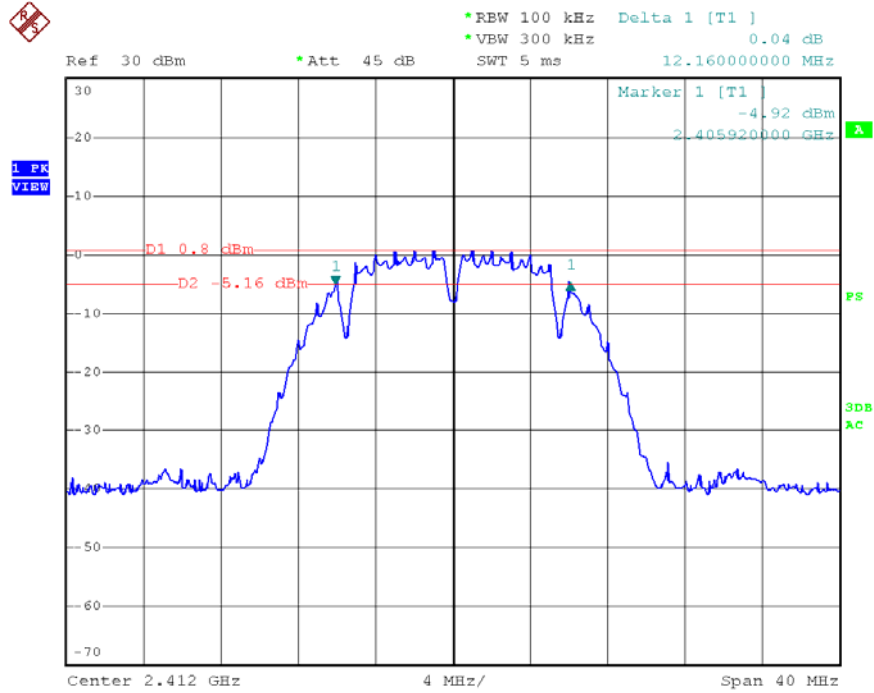

Date: 5.DEC.2013 11:25:13

Test Mode: 802.11b---Mid

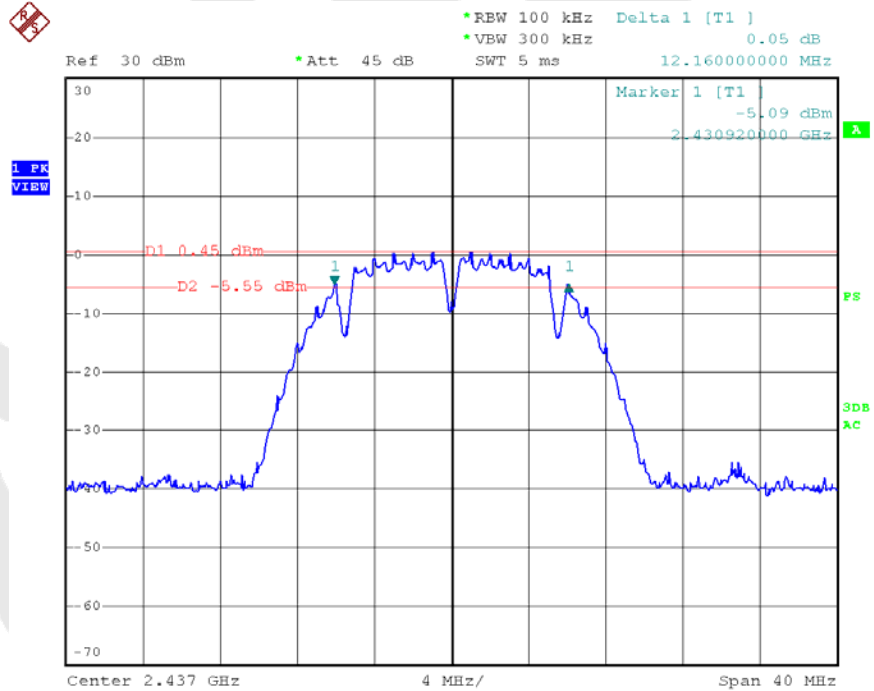

Date: 5.DEC.2013 11:26:48

Test Mode: 802.11b---High

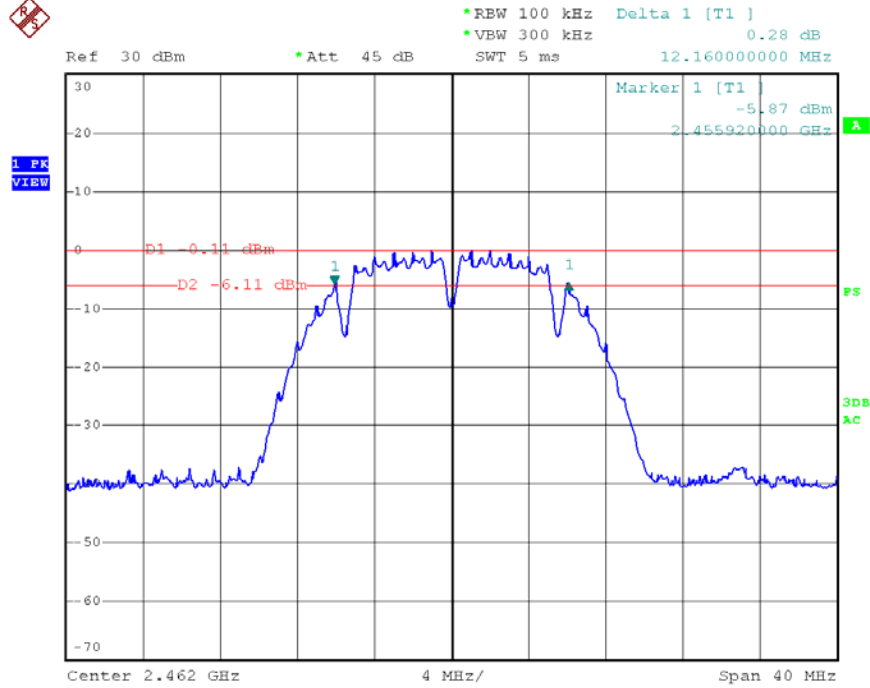

Date: 5.DEC.2013 11:27:55

Test Mode: 802.11g---Low

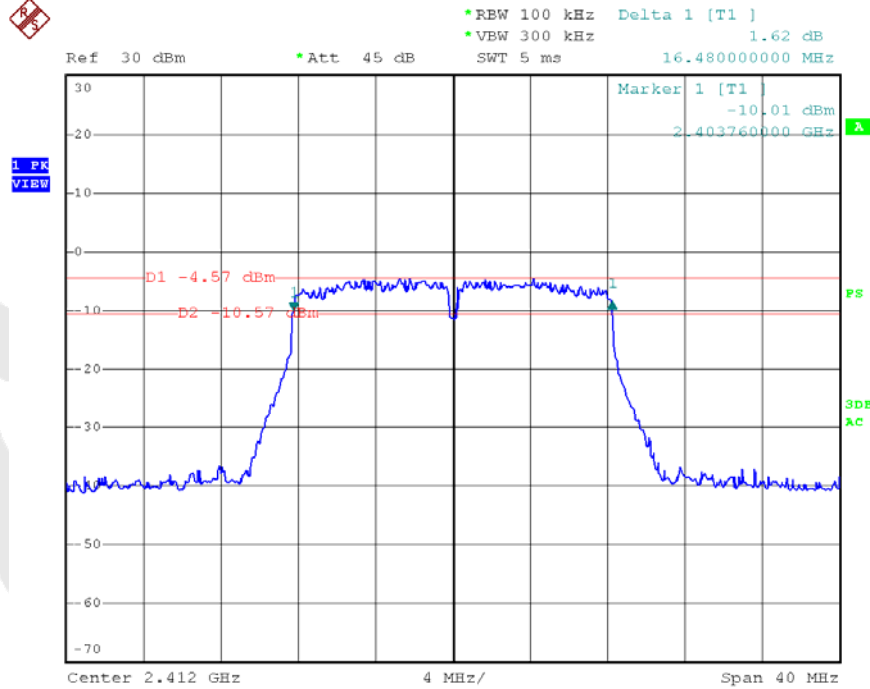

Date: 10.DEC.2013 08:32:30

Test Mode: 802.11g---Mid

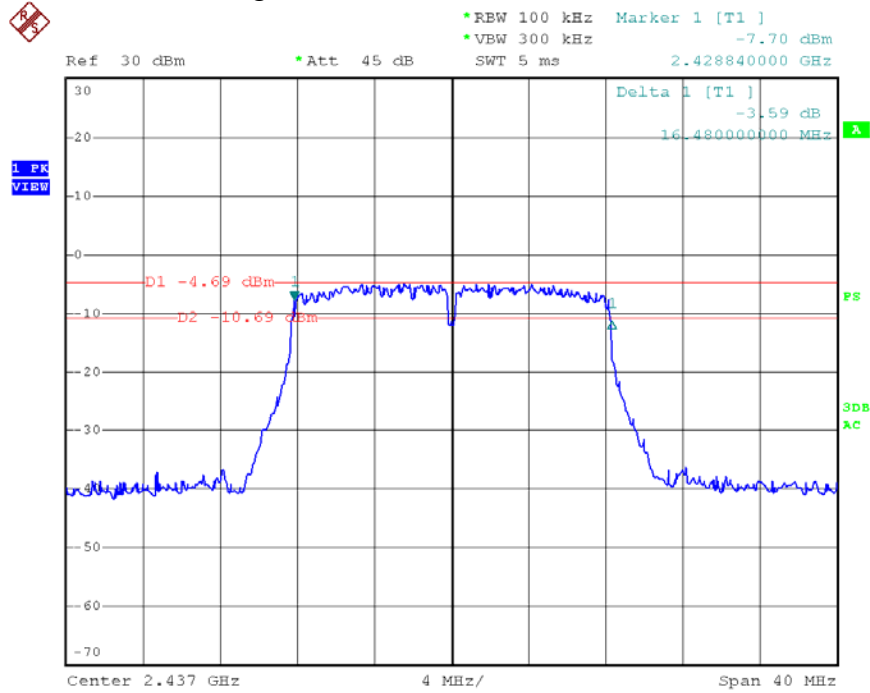

Date: 10.DEC.2013 08:33:53

Test Mode: 802.11g---High

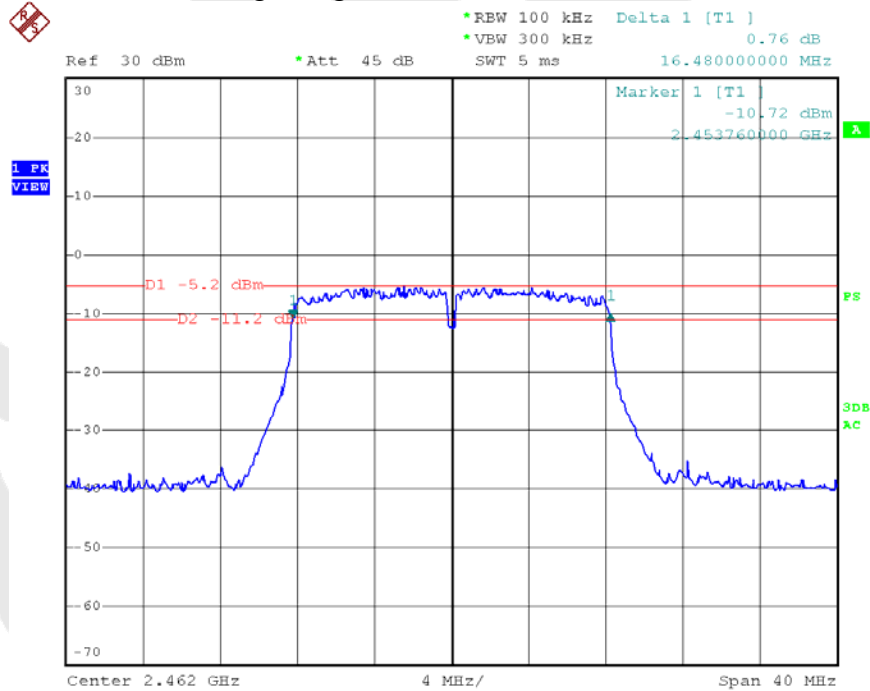

Date: 10.DEC.2013 08:36:05

Test Mode: 802.11n (HT20)---Low

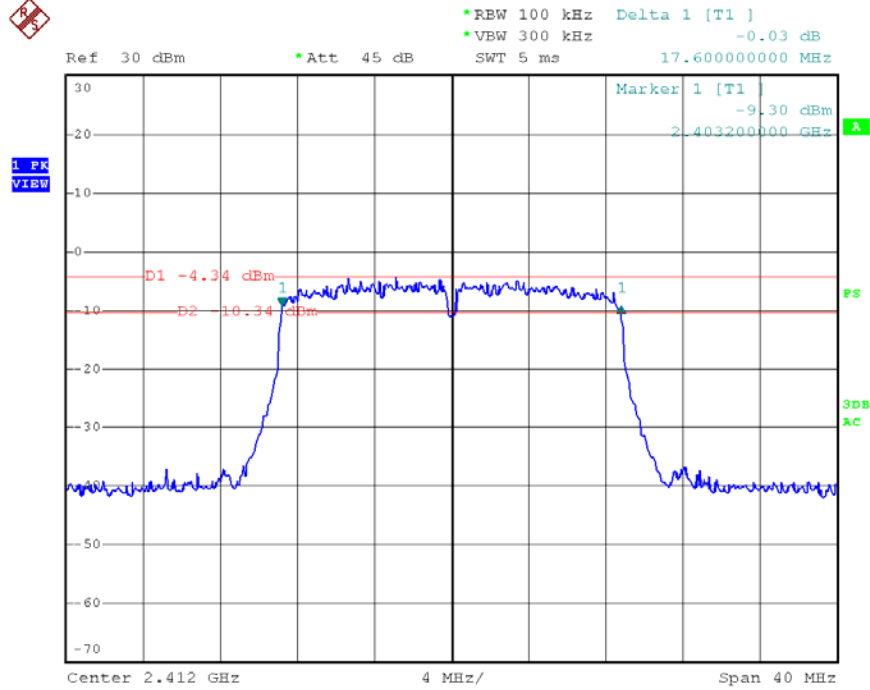

Date: 10.DEC.2013 08:38:23

Test Mode: 802.11n (HT20)---Mid

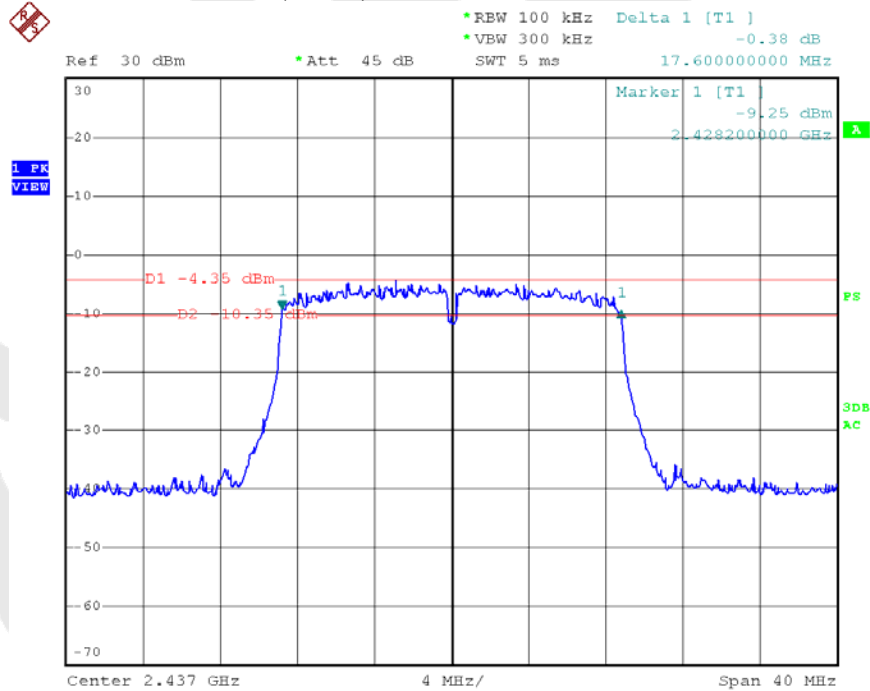

Date: 10.DEC.2013 08:39:52

Test Mode: 802.11n (HT20)---High

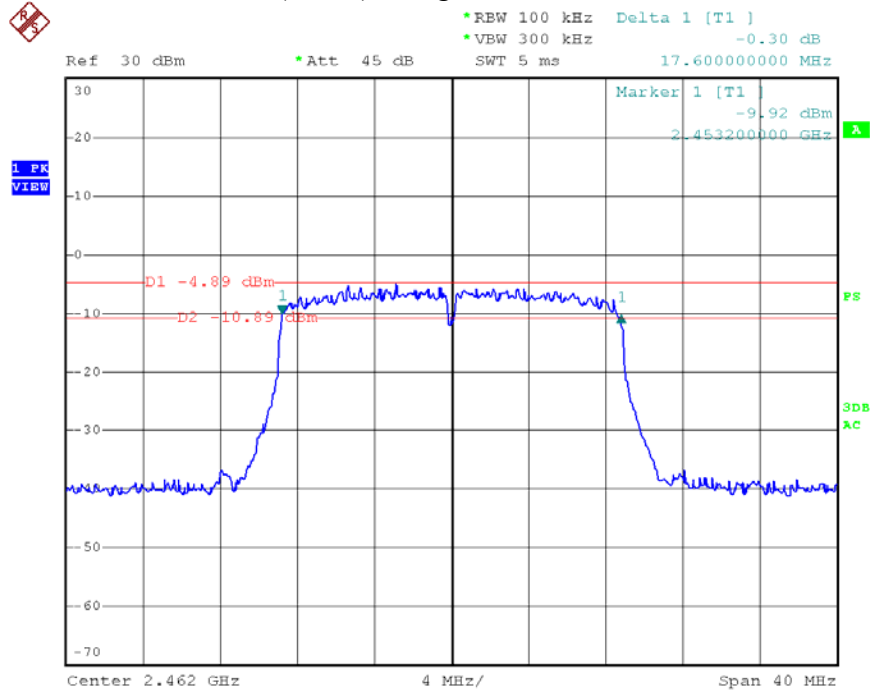

Date: 10.DEC.2013 08:40:52

Test Mode: 802.11n (HT40)---Low

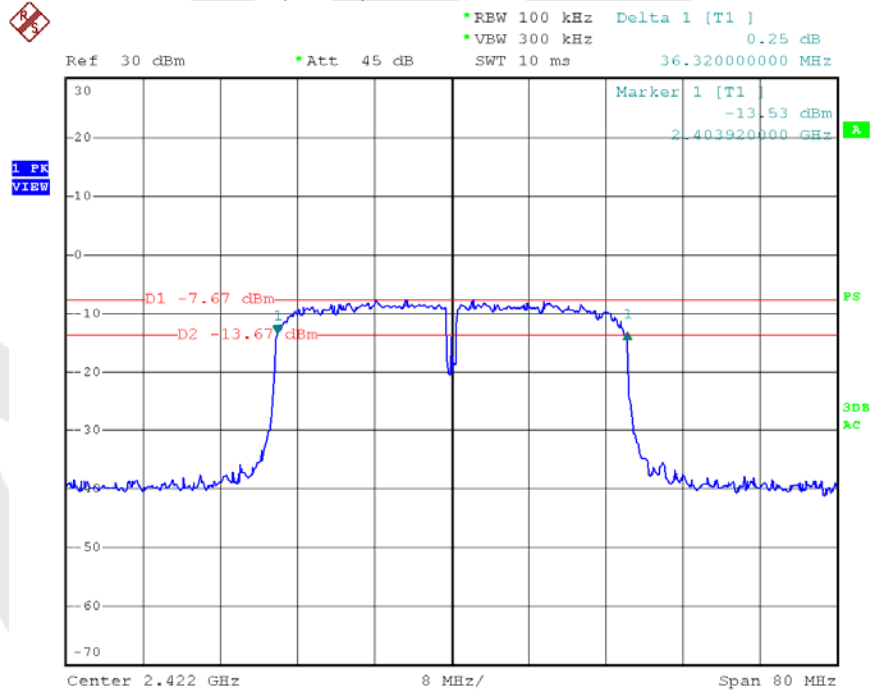

Date: 10.DEC.2013 08:42:10

Test Mode: 802.11n (HT40)---Mid

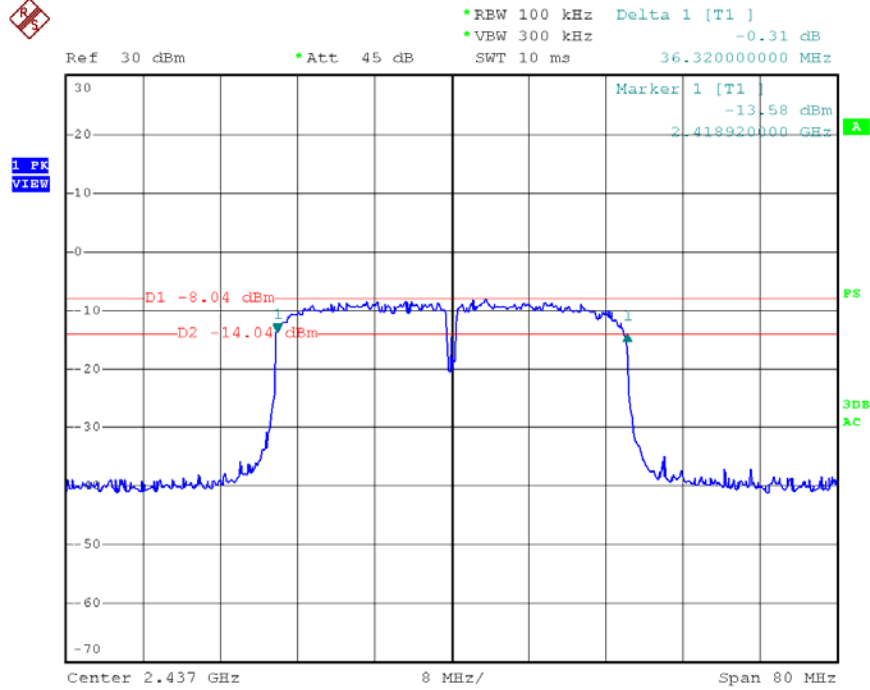

Date: 10.DEC.2013 08:43:28

Test Mode: 802.11n (HT40)---High

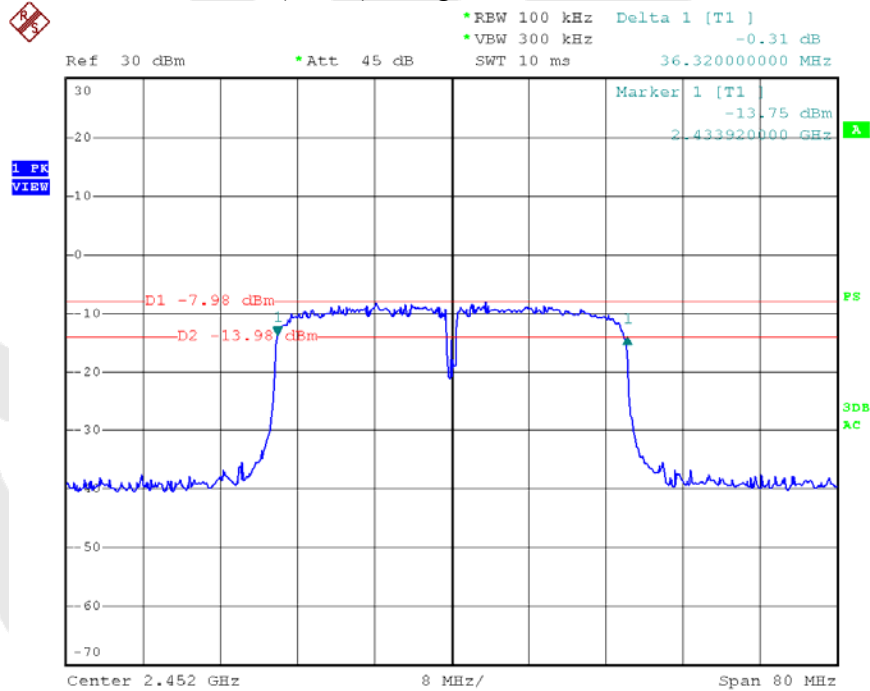

Date: 10.DEC.2013 08:45:05

4.3. Maximum Peak output power test

a. Limit

The maximum peak output power of the intentional radiator shall not exceed the following:

1. For systems using digital modulation in the bands of 902-928 MHz, 2400-2483.5 MHz, and 5725-5850 MHz: 1 watt (30dBm).
2. Except as shown in paragraphs (b)(3) (i), (ii) and (iii) of this section, if transmitting antenna of directional gain greater than 6 dBi are used the peak output power from the intentional radiator shall be reduced below the stated values in paragraphs (b)(1) or (b)(2) of this section, as appropriate, by the amount in dB that the directional gain of the antenna exceeds 6 dBi.

b. Configuration of Measurement

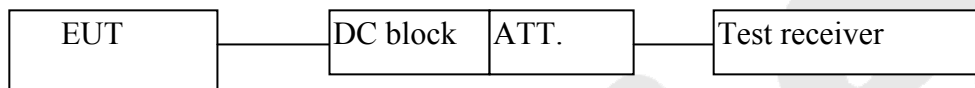

c. Data Rates

IEEE802.11b: Channel 1(2412MHz), Channel 6(2437MHz) and Channel 11(2462MHz) with 1 Mbps data rate (worst case) are chosen for the final testing.

IEEE802.11g: Channel 1(2412MHz), Channel 6(2437MHz) and Channel 11(2462MHz) with 6 Mbps data rate (the worst case) are chosen for the final testing.

IEEE802.11n (HT20: Channel 1(2412MHz), Channel 6(2437MHz) and Channel 11(2462MHz) with 6.5Mbps data rate (the worst case) are chosen for the final testing.

IEEE802.11n (HT40: Channel 3(2422MHz), Channel 6(2437MHz) and Channel 9(2452MHz) with 13.5Mbps data rate (the worst case) are chosen for the final testing.

d. Test Procedure

This test was according the kDB 558074 9.1.2:

1. This procedure may be used when the maximum available RBW of the measurement instrument is less than the DTS bandwidth.
2. Set the RBW = 1 MHz.
3. Set the VBW $\geq 3 * RBW = 3$ MHz.
4. Set the span $\geq 1.5 * DTS$ bandwidth.
5. Detector = peak.
6. Sweep time = auto couple.
7. Trace mode = max hold.
8. Allow trace to fully stabilize.
9. Use the instrument's band/channel power measurement function with the band limits set equal to the DTS bandwidth edges (for some instruments, this may require a manual override to select peak detector). If the instrument does not have a band power function, sum the spectrum levels (in linear power units) at intervals equal to the RBW extending across the DTS bandwidth.

e. Test Equipment

Same as the equipment listed in 4.2.

f. Test Results

Pass.

g. Test Data

Test mode: IEEE 802.11b

Channel	Frequency (MHz)	Maximum transmit power (dBm)	Limit		Result
			(dBm)	(watts)	
Low	2412	16.17	30	1	Pass
Mid	2437	15.47			Pass
High	2462	14.87			Pass

Test mode: IEEE 802.11g

Channel	Frequency (MHz)	Maximum transmit power (dBm)	Limit		Result
			(dBm)	(watts)	
Low	2412	19.20	30	1	Pass
Mid	2437	18.95			Pass
High	2462	18.02			Pass

Test mode: IEEE 802.11n (HT20)

Channel	Frequency (MHz)	Maximum transmit power (dBm)	Limit		Result
			(dBm)	(watts)	
Low	2412	19.23	30	1	Pass
Mid	2437	18.51			Pass
High	2462	17.86			Pass

Test mode: IEEE 802.11n (HT40)

Channel	Frequency (MHz)	Maximum transmit power (dBm)	Limit		Result
			(dBm)	(watts)	
Low	2422	18.50	30	1	Pass
Mid	2437	18.17			Pass
High	2452	17.79			Pass

Test Mode: 802.11b---Low



Ref 30 dBm *Att 45 dB *RBW 1 MHz *VBW 3 MHz SWT 2.5 ms Marker 1 [T1] 7.35 dBm 2.413440000 GHz

1 PK
MAXH

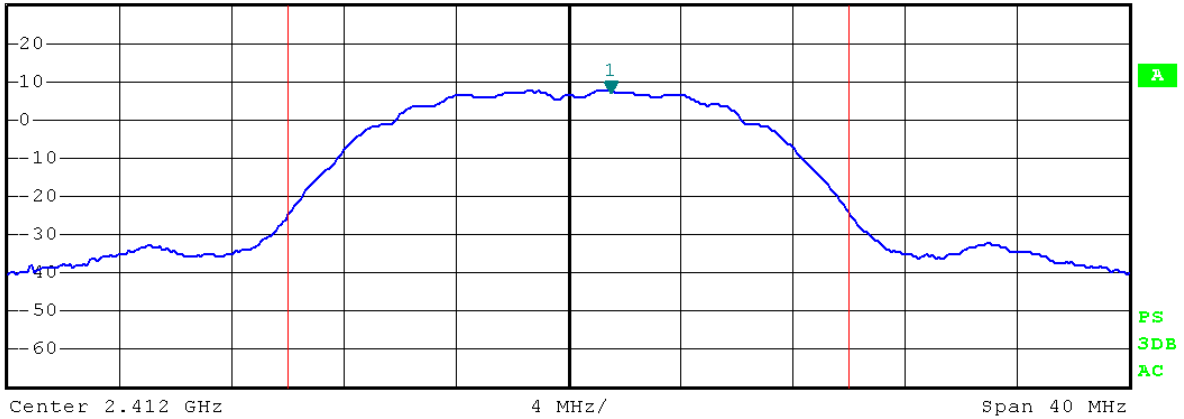

Tx Channel
Bandwidth 20 MHz Power 16.17 dBm

Test Mode: 802.11b---Mid



Ref 30 dBm *Att 45 dB *RBW 1 MHz *VBW 3 MHz SWT 2.5 ms Marker 1 [T1] 6.65 dBm 2.438360000 GHz

1 PK
MAXH

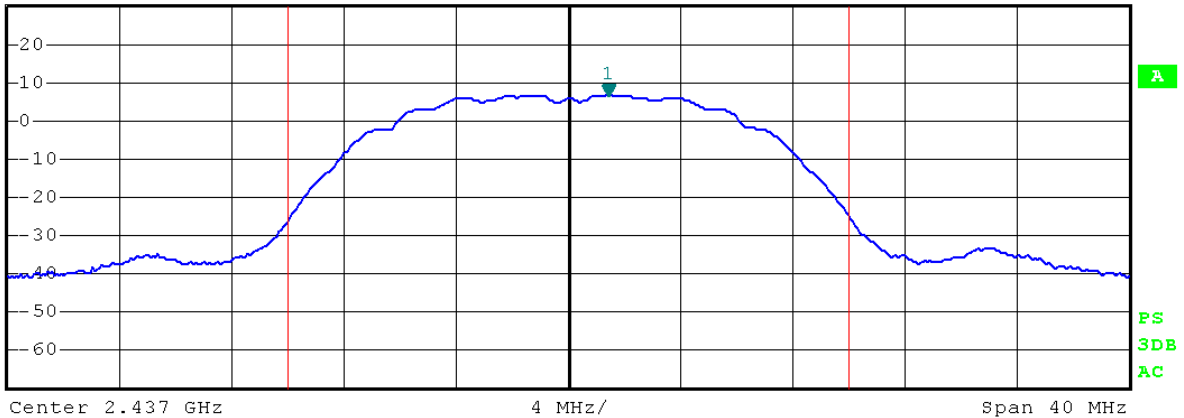

Tx Channel
Bandwidth 20 MHz Power 15.47 dBm

Test Mode: 802.11b---High



Ref 30 dBm *Att 45 dB *RBW 1 MHz *VBW 3 MHz SWT 2.5 ms Marker 1 [T1] 6.08 dBm 2.463440000 GHz

1 PK
MAXH

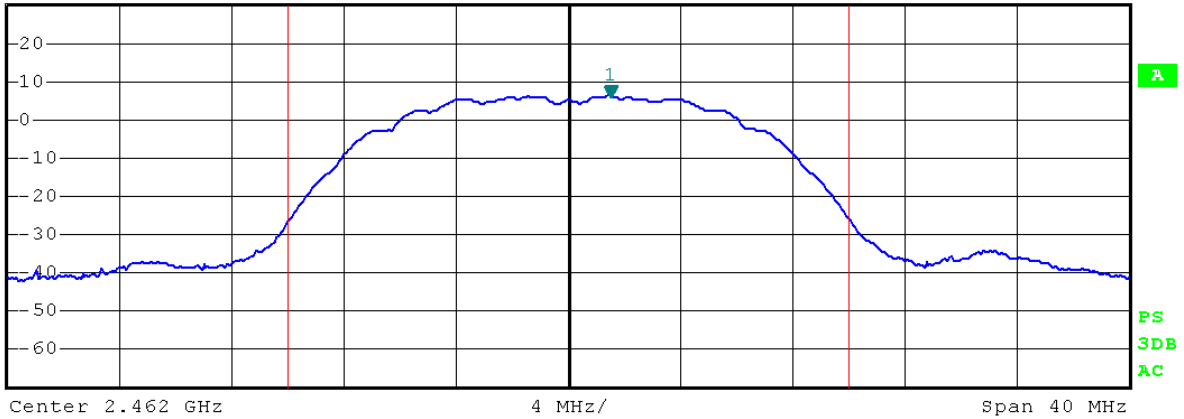

Tx Channel

Bandwidth 20 MHz Power 14.87 dBm

Test Mode: 802.11g---Low



Ref 30 dBm *Att 45 dB *RBW 1 MHz *VBW 3 MHz SWT 2.5 ms Marker 1 [T1] 8.71 dBm 2.413520000 GHz

1 PK
MAXH

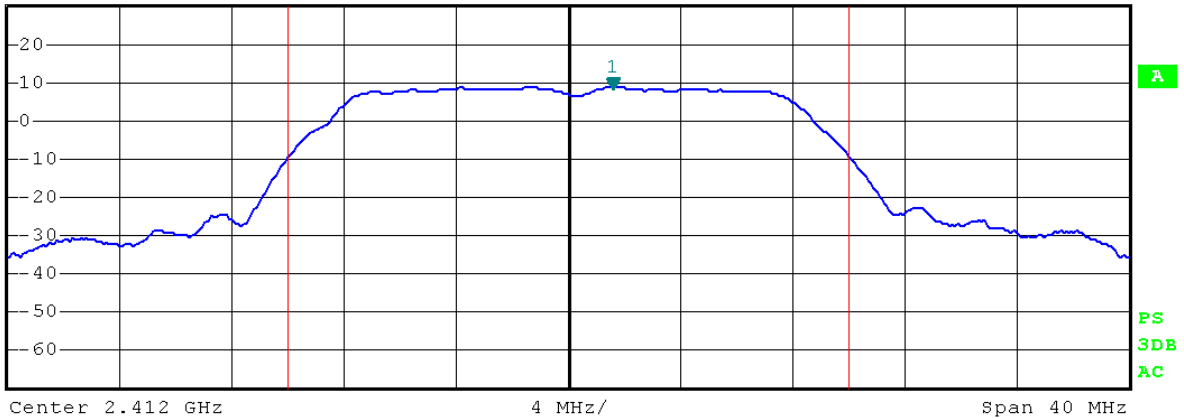

Tx Channel

Bandwidth 20 MHz Power 19.20 dBm

Test Mode: 802.11g---Mid



Ref 30 dBm *Att 45 dB *RBW 1 MHz *VBW 3 MHz SWT 2.5 ms Marker 1 [T1] 8.93 dBm 2.433960000 GHz

1 PK
MAXH

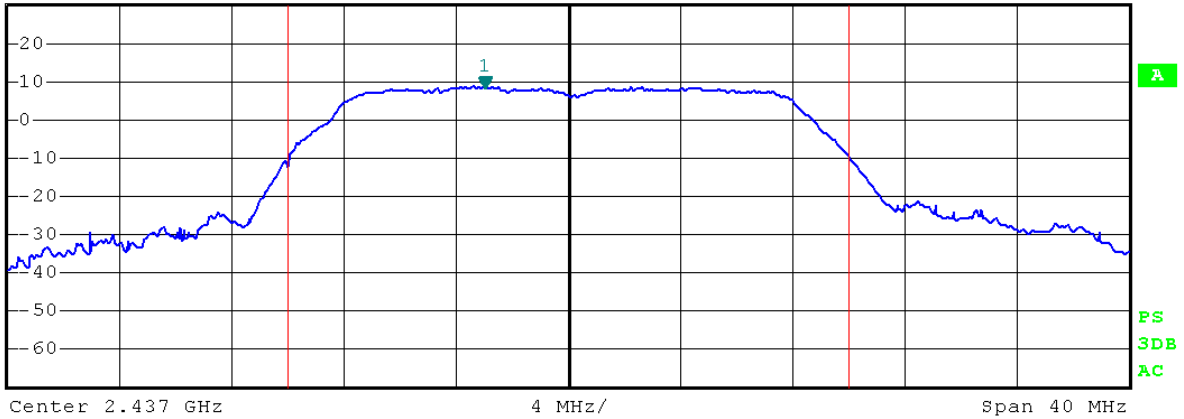

Tx Channel
Bandwidth 20 MHz Power 18.95 dBm

Test Mode: 802.11g---High



Ref 30 dBm *Att 45 dB *RBW 1 MHz *VBW 3 MHz SWT 2.5 ms Marker 1 [T1] 7.60 dBm 2.463680000 GHz

1 PK
MAXH

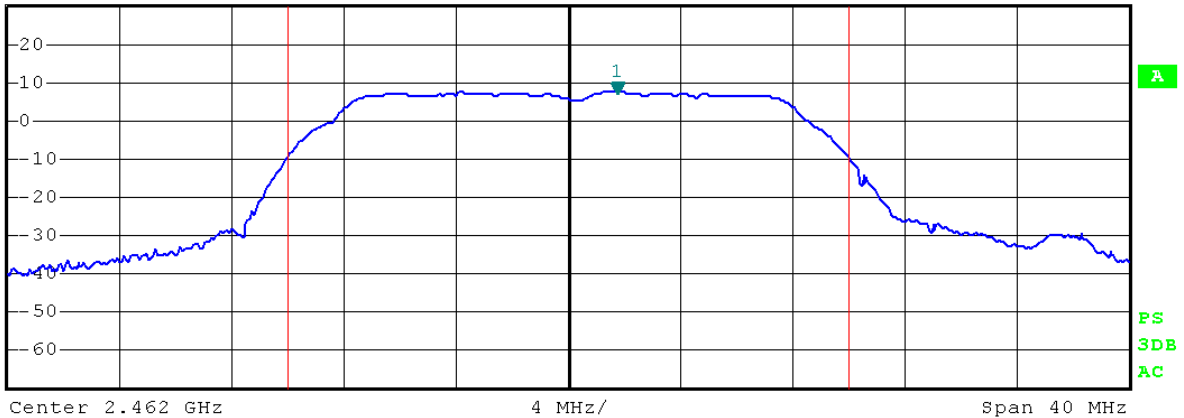

Tx Channel
Bandwidth 20 MHz Power 18.02 dBm

Test Mode: 802.11n(HT20)---Low



*RBW 1 MHz
*VBW 3 MHz
SWT 2.5 ms
Marker 1 [T1]
8.35 dBm
2.415200000 GHz

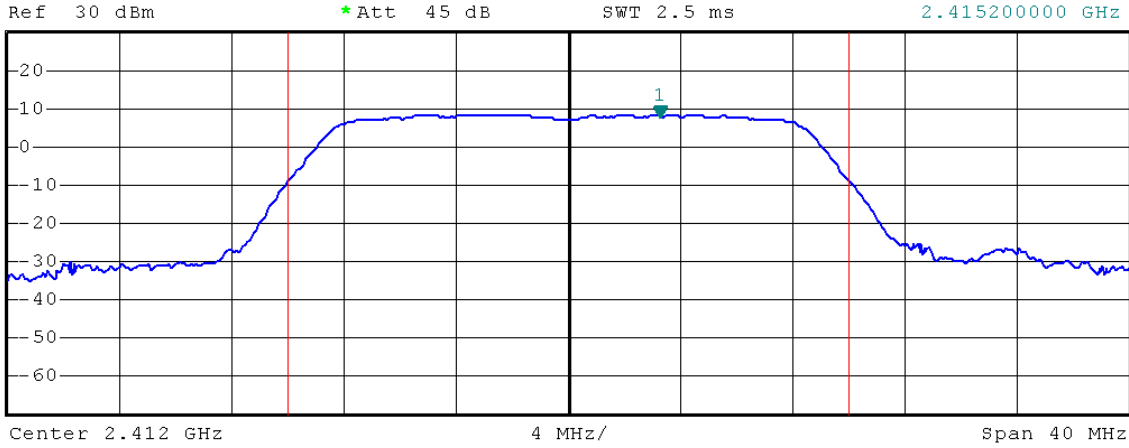

Tx Channel
Bandwidth 20 MHz Power 19.23 dBm

Test Mode: 802.11n(HT20)---Mid



*RBW 1 MHz
*VBW 3 MHz
SWT 2.5 ms
Marker 1 [T1]
7.60 dBm
2.434840000 GHz

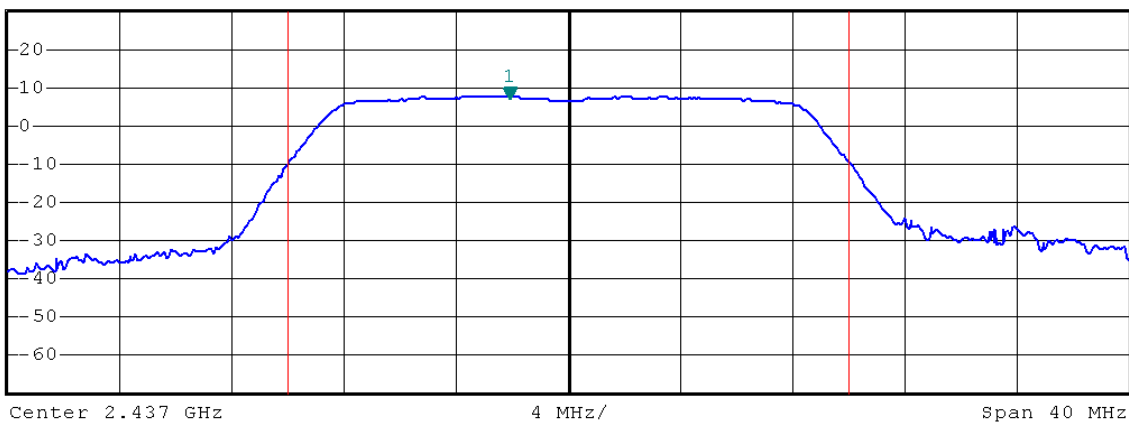

Tx Channel
Bandwidth 20 MHz Power 18.51 dBm

Test Mode: 802.11n(HT20)---High



*RBW 1 MHz
*VBW 3 MHz
SWT 2.5 ms
Marker 1 [T1]
6.93 dBm
2.459840000 GHz

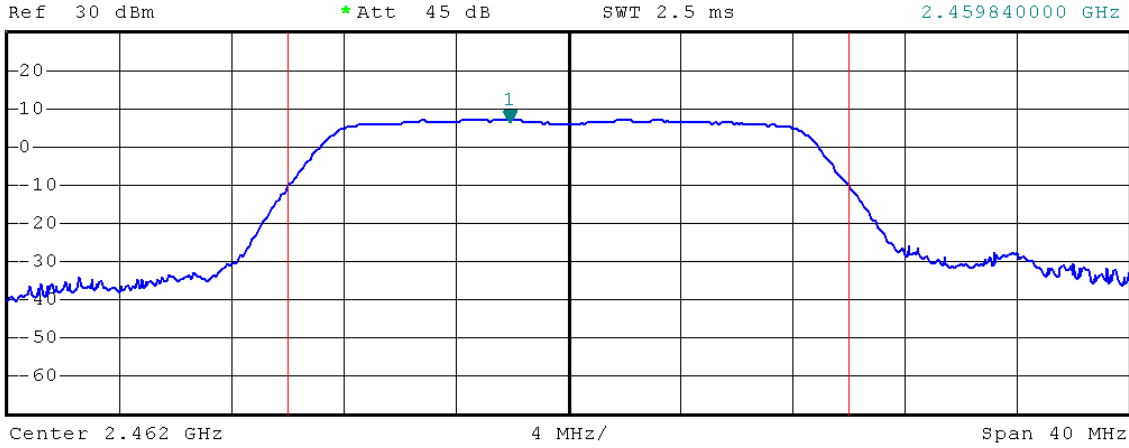

Tx Channel
Bandwidth 20 MHz Power 17.86 dBm

Test Mode: 802.11n(HT40)---Low



*RBW 1 MHz
*VBW 3 MHz
SWT 2.5 ms
Marker 1 [T1]
4.52 dBm
2.424880000 GHz

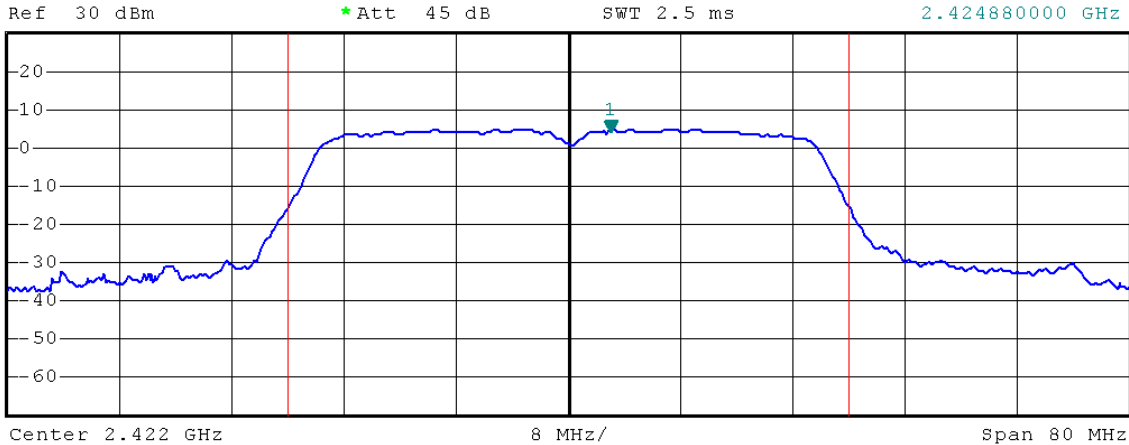

Tx Channel
Bandwidth 40 MHz Power 18.50 dBm

Test Mode: 802.11n(HT40)---Mid



*RBW 1 MHz
*VBW 3 MHz
SWT 2.5 ms
Marker 1 [T1]
4.25 dBm
2.433800000 GHz

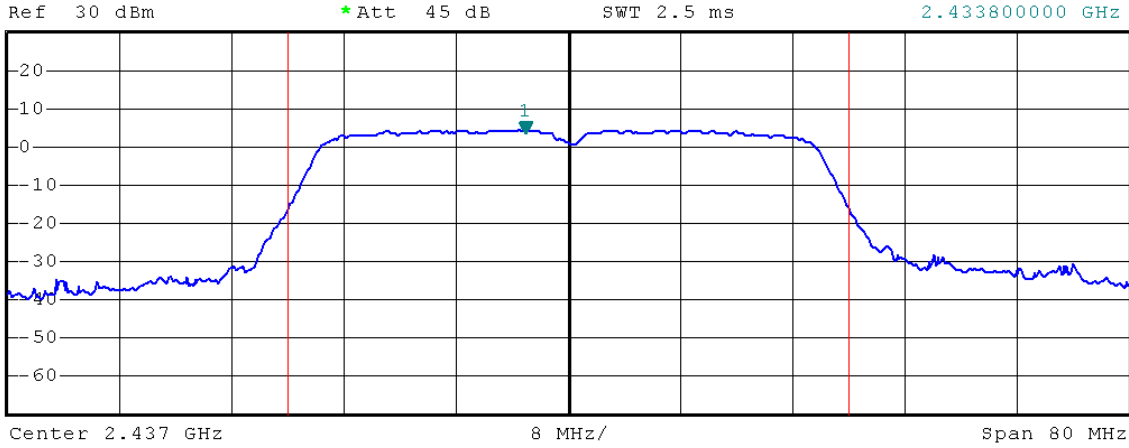

Tx Channel
Bandwidth 40 MHz Power 18.17 dBm

Test Mode: 802.11n(HT40)---High



*RBW 1 MHz
*VBW 3 MHz
SWT 2.5 ms
Marker 1 [T1]
3.78 dBm
2.455040000 GHz

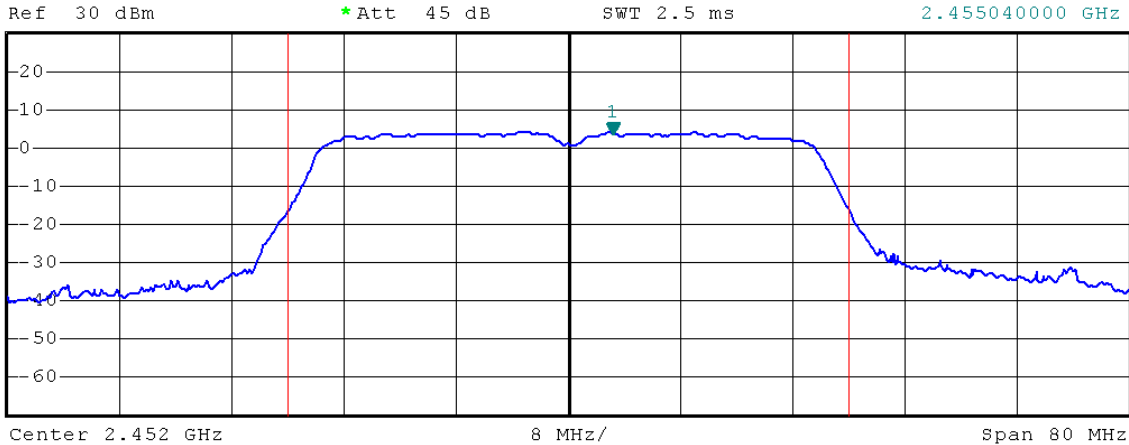

Tx Channel
Bandwidth 40 MHz Power 17.79 dBm

4.4. Band Edges Measurement

a. Limit

According to §15.247(c), in any 100 kHz bandwidth outside the frequency bands in which the spread spectrum intentional radiator is operating, the radio frequency power that is produced by the intentional radiator shall be at least 20dB below that in the 100kHz bandwidth within the band that contains the highest level of the desired power. In addition, radiated emissions which fall in the restricted bands, as defined in §15.205(a), must also comply with the radiated emission limits specified in §15.209(a).

b. Test Procedure

1. Conducted Method:

- 1) Set RBW=100KHz, VBW=300KHz
- 2) Detector=peak
- 3) Sweep time= auto
- 4) Trace mode=max hold.

2. Radiated Method:

- 1) The EUT is placed on a turntable, which is 0.8m above the ground plane.
- 2) The turntable shall be rotated for 360 degrees to determine the position of maximum emission level.
- 3) EUT is set 3m away from the receiving antenna, which is varied from 1m to 4m to find out the highest emission.
- 4) Peak detector: RBW=1MHz, VBW=3MHz, SWT=AUTO
Average detector: RBW=1MHz, VBW=10Hz, SWT=AUTO
The EUT is tested in 9*6*6 Chamber.
- 5) Repeat the procedures until all the PEAK and AVERAGE versus POLARIZATION are measured.

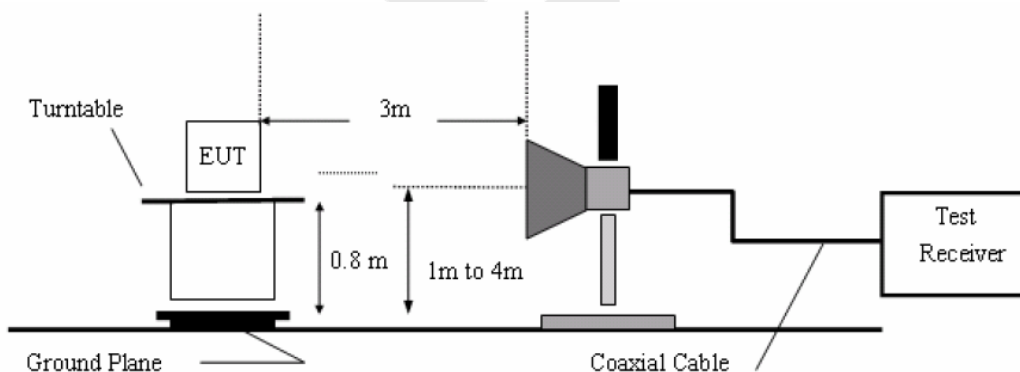

c. Test Equipment

Same as the equipment listed in 4.2.

d. Test Results

Pass.

e. Test Plots

See the following page.

Test Mode: 802.11b ---Low

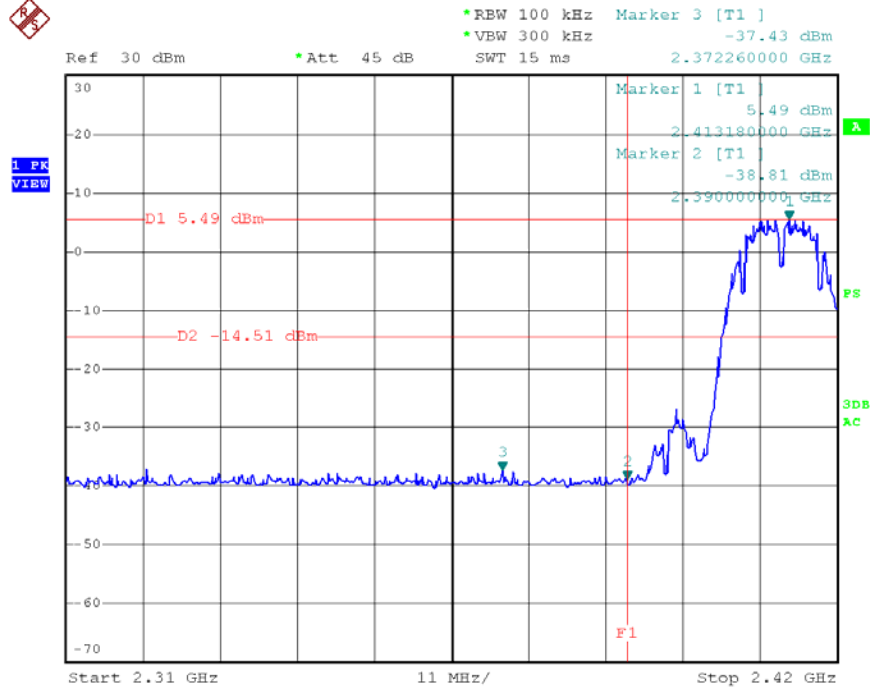

Date: 5.DEC.2013 11:20:37

Test Mode: 802.11b ---High

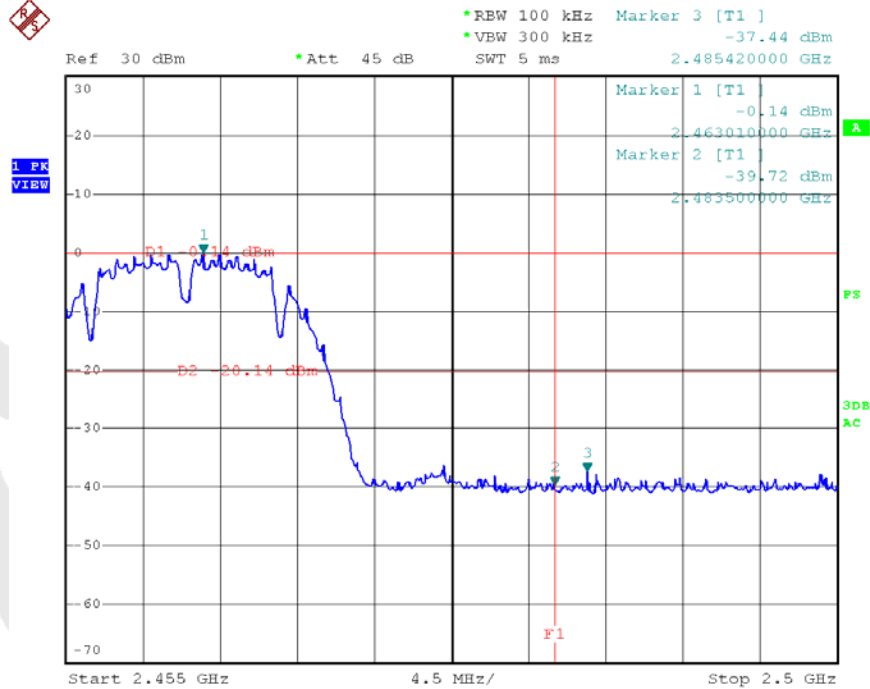

Date: 5.DEC.2013 11:22:30

Test Mode: 802.11g ---Low

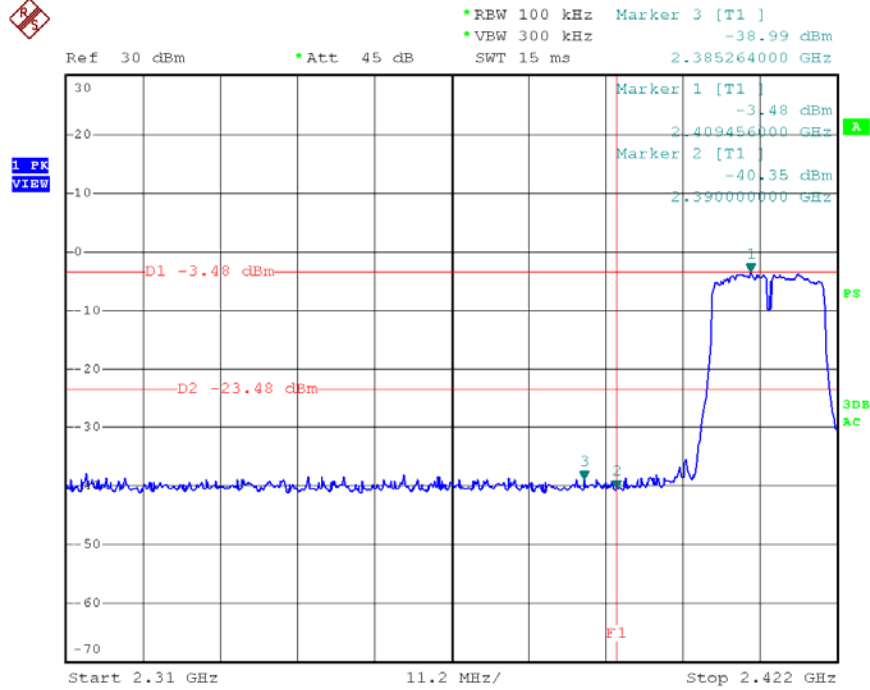

Date: 10.DEC.2013 08:21:23

Test Mode: 802.11g ---High

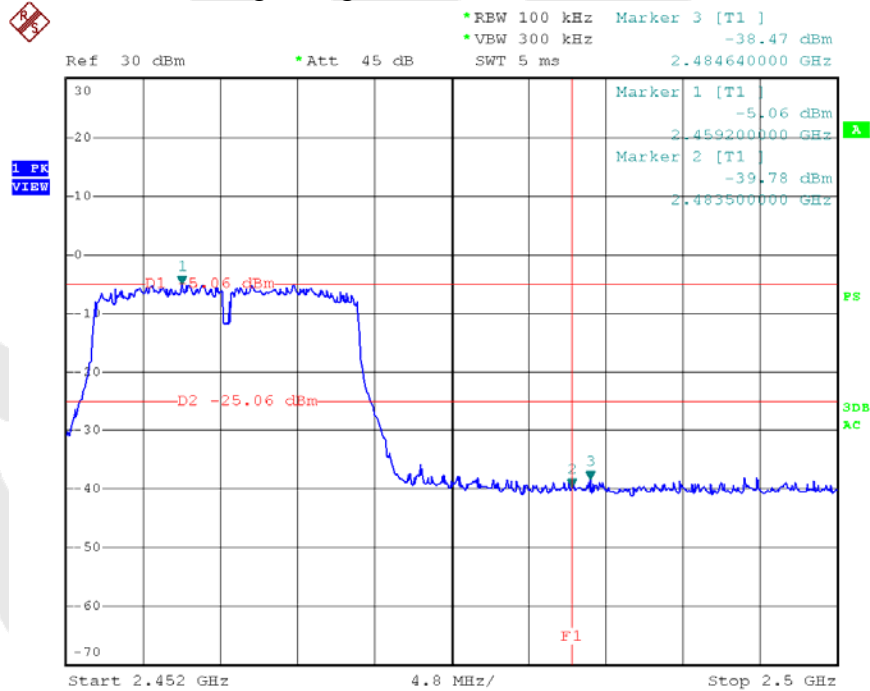

Date: 10.DEC.2013 08:25:41

Test Mode: 802.11n (HT20) ---Low

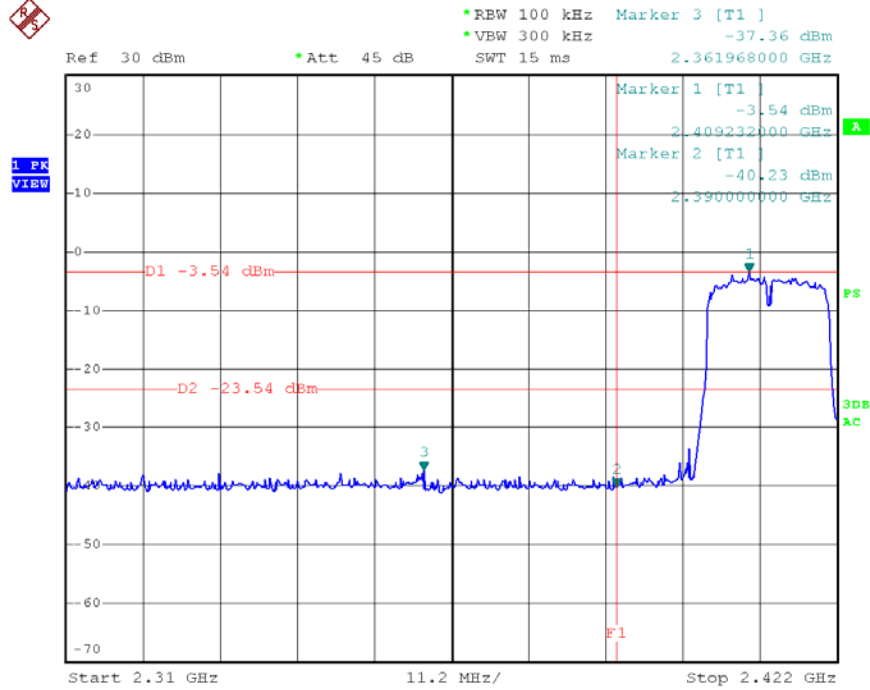

Date: 10.DEC.2013 08:22:57

Test Mode: 802.11n (HT20)---High

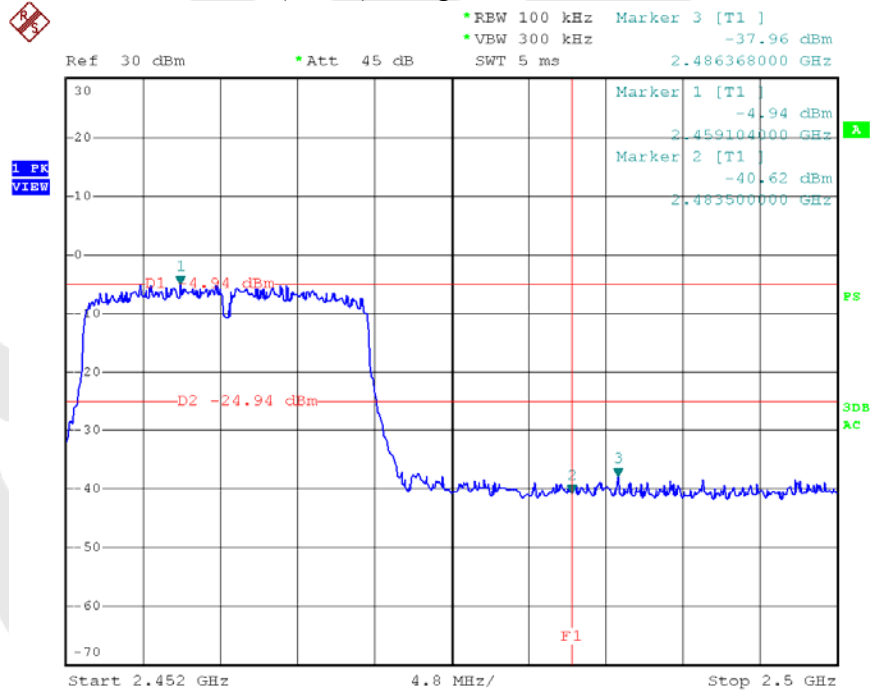

Date: 10.DEC.2013 08:26:27

Test Mode: 802.11n (HT40) ---Low

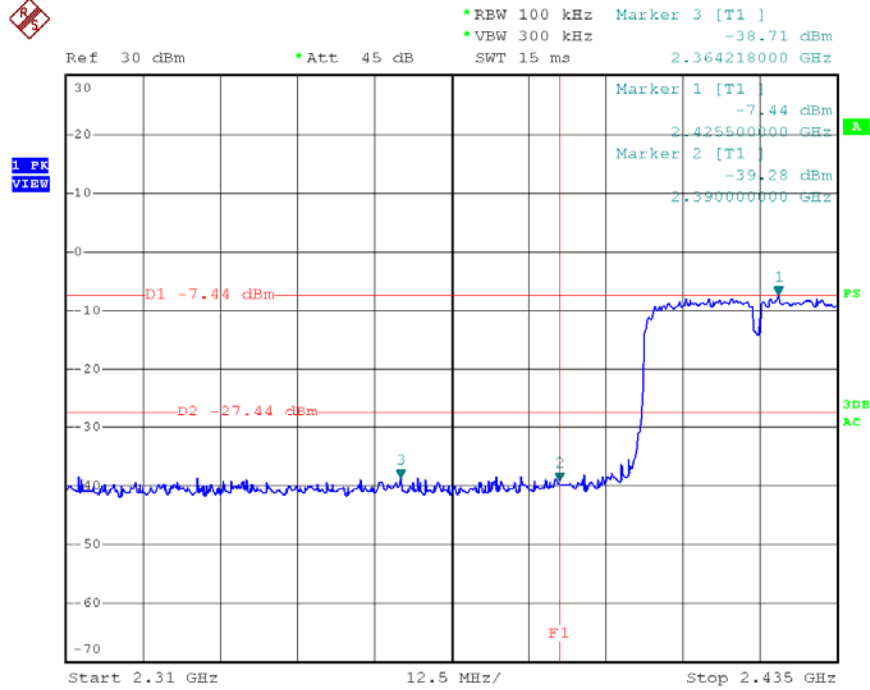

Date: 10.DEC.2013 08:23:58

Test Mode: 802.11n (HT40) ---High

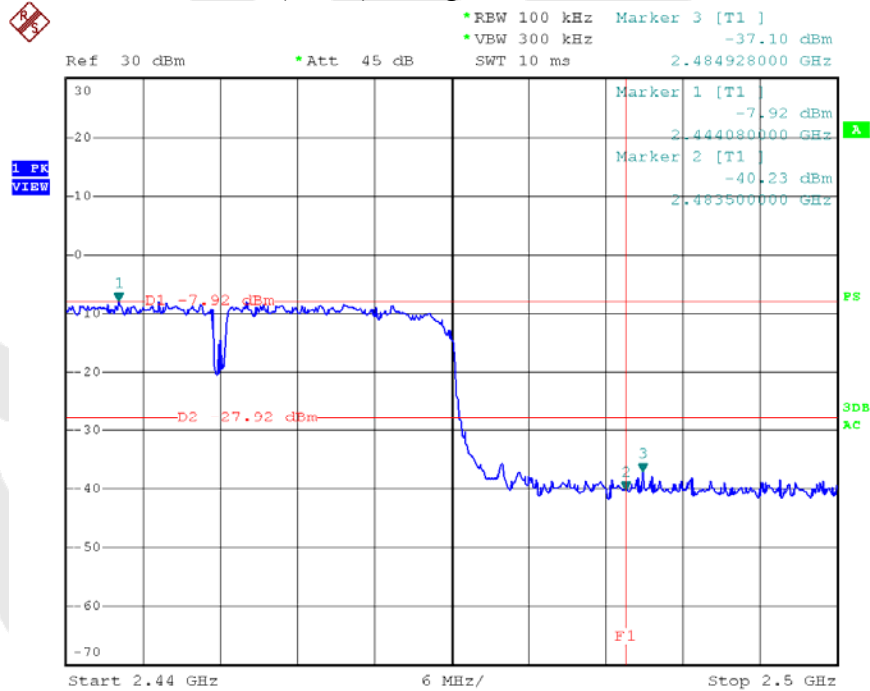

Date: 10.DEC.2013 08:27:34

The Worst Mode: 802.11b

2412MHz

Horizontal-PEAK:

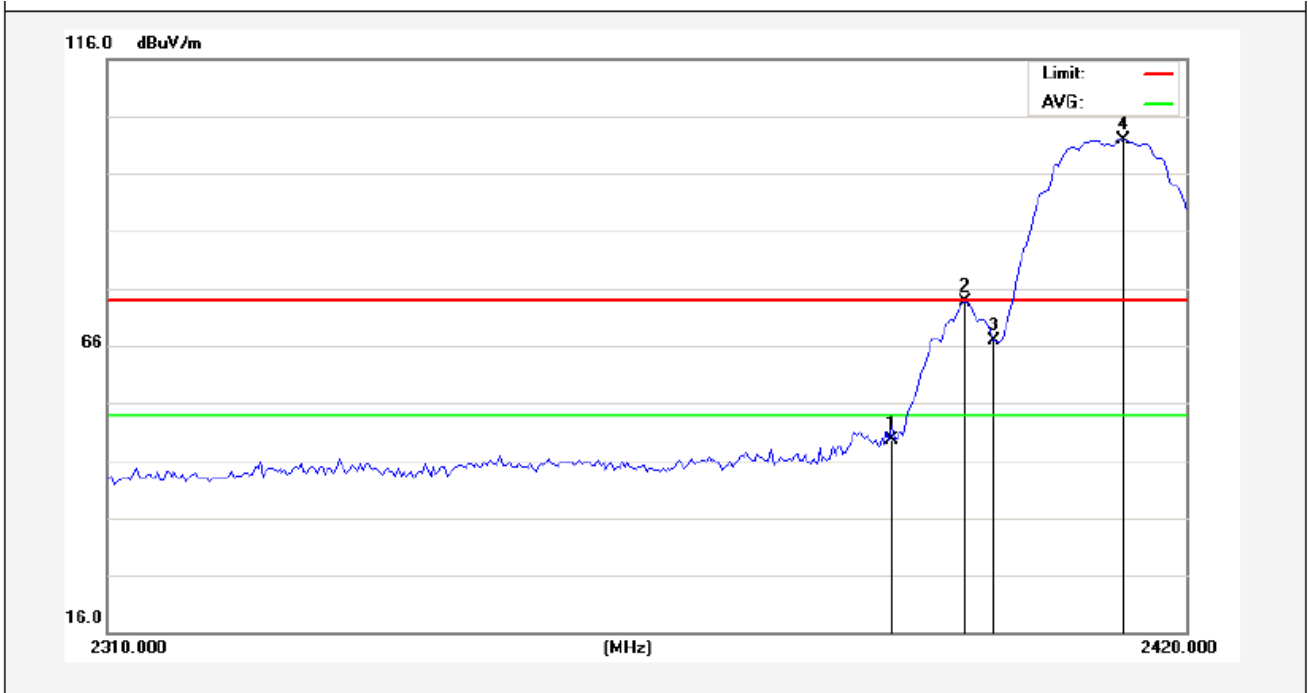

No.	Freq. (MHz)	Reading (dBuV/m)	Factor (dB/m)	Result (dBuV/m)	Limit (dBuV/)	Over Limit (dB)	Detector	Height (cm)	degree (deg)	Remark
1	2390.000	52.12	-2.51	49.61	74.00	-24.39	peak			
2	2397.175	76.20	-2.50	73.70	74.00	-0.30	peak			
3	2400.000	69.48	-2.49	66.99	74.00	-7.01	peak			
4	2413.675	104.24	-2.46	101.78	74.00	27.78	peak			

A.M.U.

Horizontal-AV:

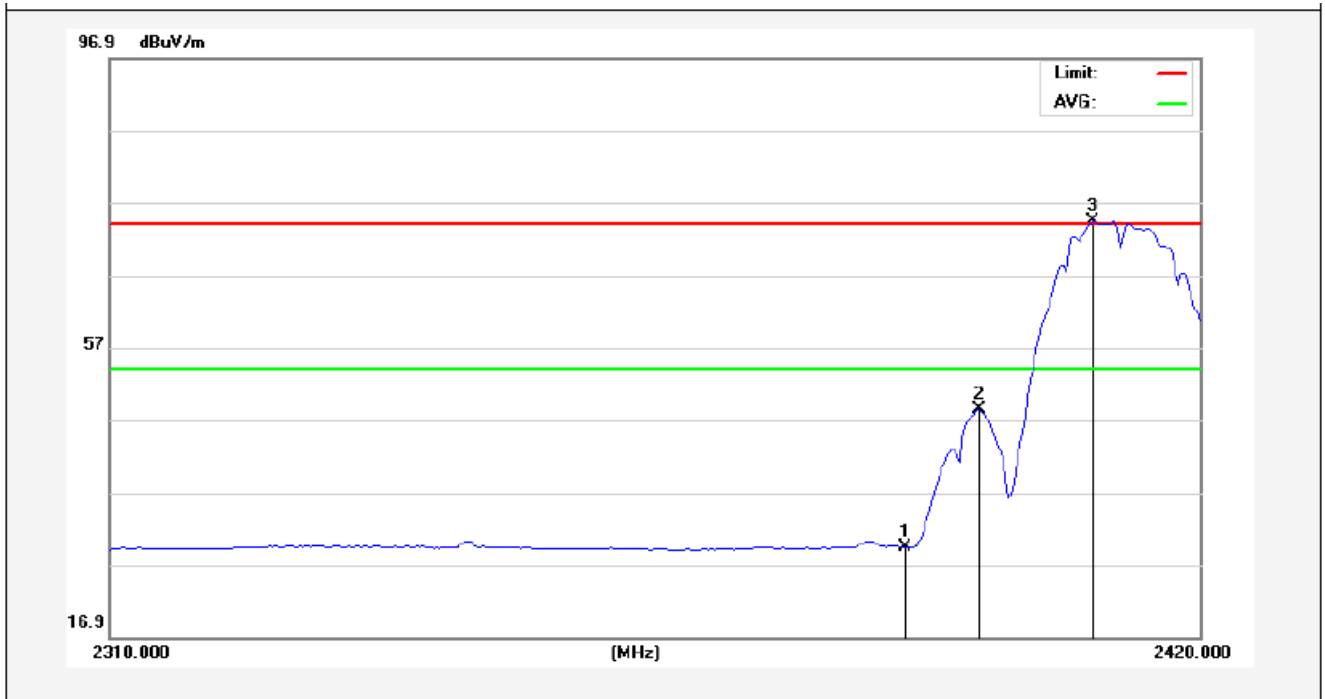

No.	Freq. (MHz)	Reading (dBuV/m)	Factor (dB/m)	Result (dBuV/m)	Limit (dBuV/)	Over Limit (dB)	Detector	Height (cm)	degree (deg)	Remark
1	2390.000	31.94	-2.51	29.43	54.00	-24.57	AVG			
2	2397.450	50.84	-2.50	48.34	54.00	-5.66	AVG			
3	2409.275	76.89	-2.47	74.42	54.00	20.42	AVG			

Anbotek

The Worst Mode: 802.11b
2412MHz
Vertical-PEAK:

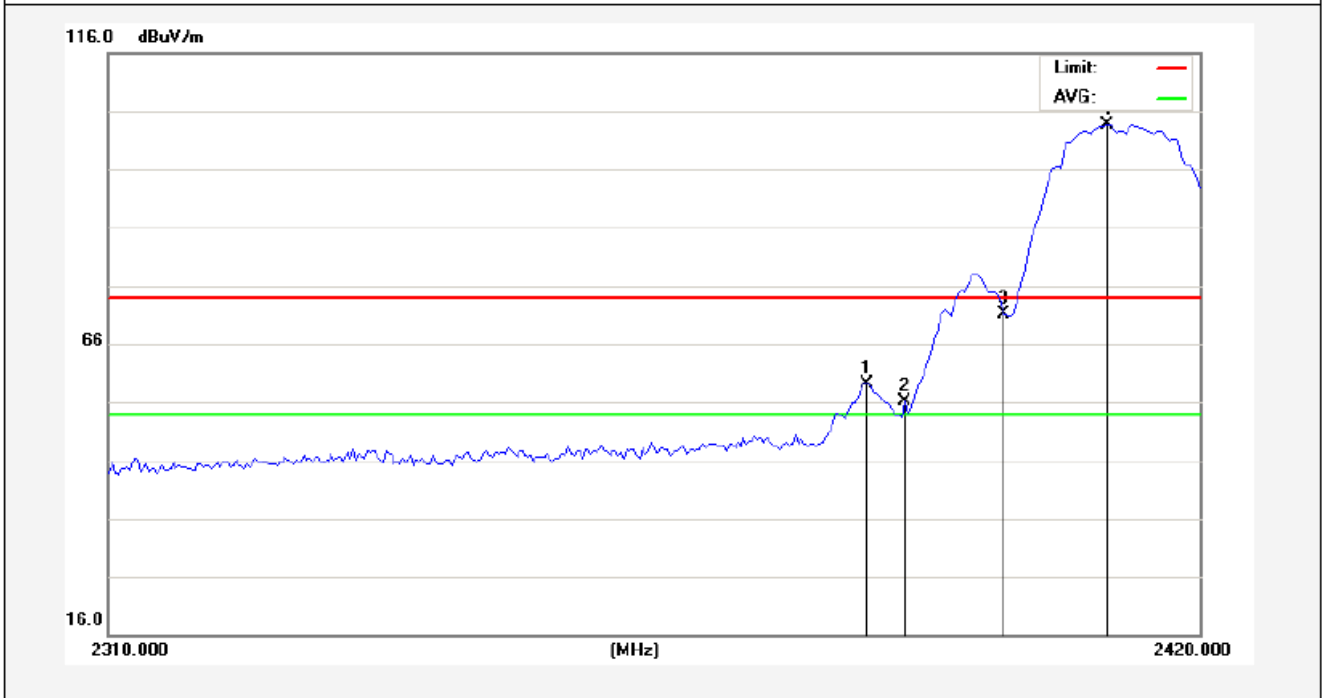

No.	Freq. (MHz)	Reading (dBuV/m)	Factor (dB/m)	Result (dBuV/m)	Limit (dBuV/)	Over Limit (dB)	Detector	Height (cm)	degree (deg)	Remark
1	2386.175	61.56	-2.52	59.04	74.00	-14.96	peak			
2	2390.000	58.74	-2.51	56.23	74.00	-17.77	peak			
3	2400.000	73.52	-2.49	71.03	74.00	-2.97	peak			
4	2410.650	106.19	-2.47	103.72	74.00	29.72	peak			

AMR

Vertical-AV:

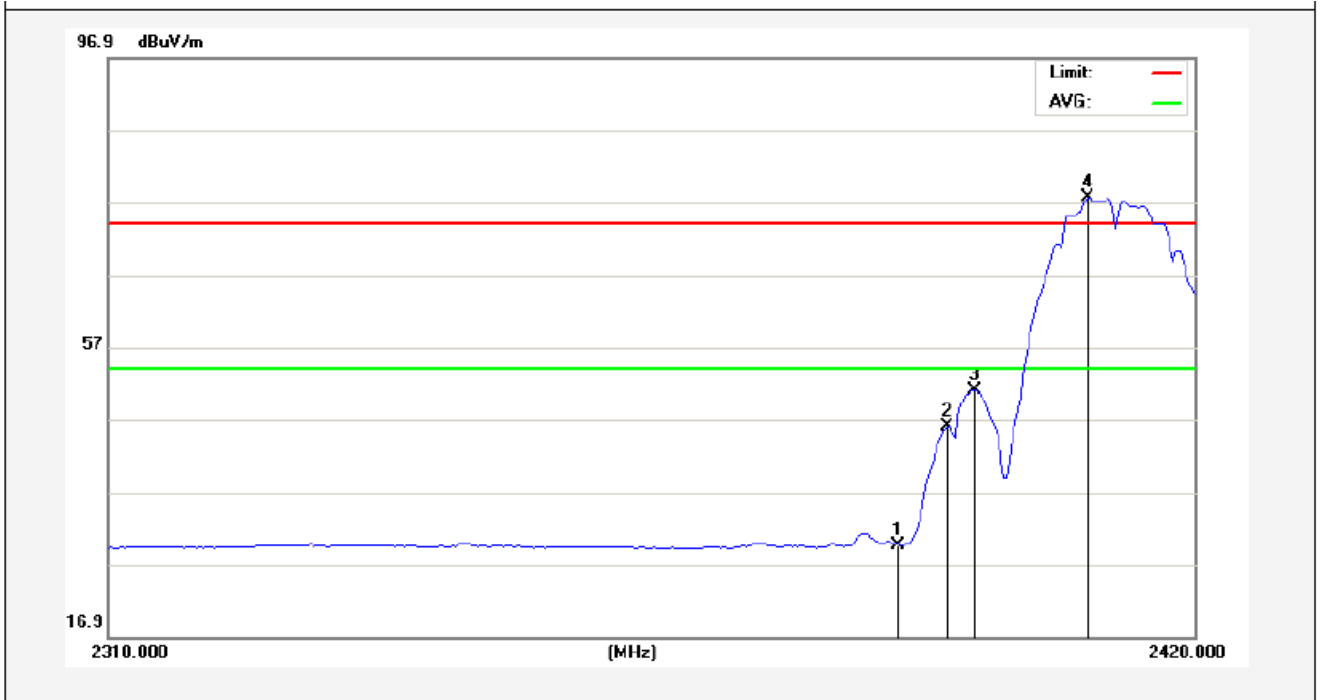

No.	Freq. (MHz)	Reading (dBuV/m)	Factor (dB/m)	Result (dBuV/m)	Limit (dBuV/)	Over Limit (dB)	Detector	Height (cm)	degree (deg)	Remark
1	2390.000	32.06	-2.51	29.55	54.00	-24.45	AVG			
2	2394.700	48.50	-2.50	46.00	54.00	-8.00	AVG			
3	2397.450	53.55	-2.50	51.05	54.00	-2.95	AVG			
4	2409.275	80.03	-2.47	77.56	54.00	23.56	AVG			

Anbotek

The Worst Mode: 802.11b

2462MHz

Horizontal-PEAK:

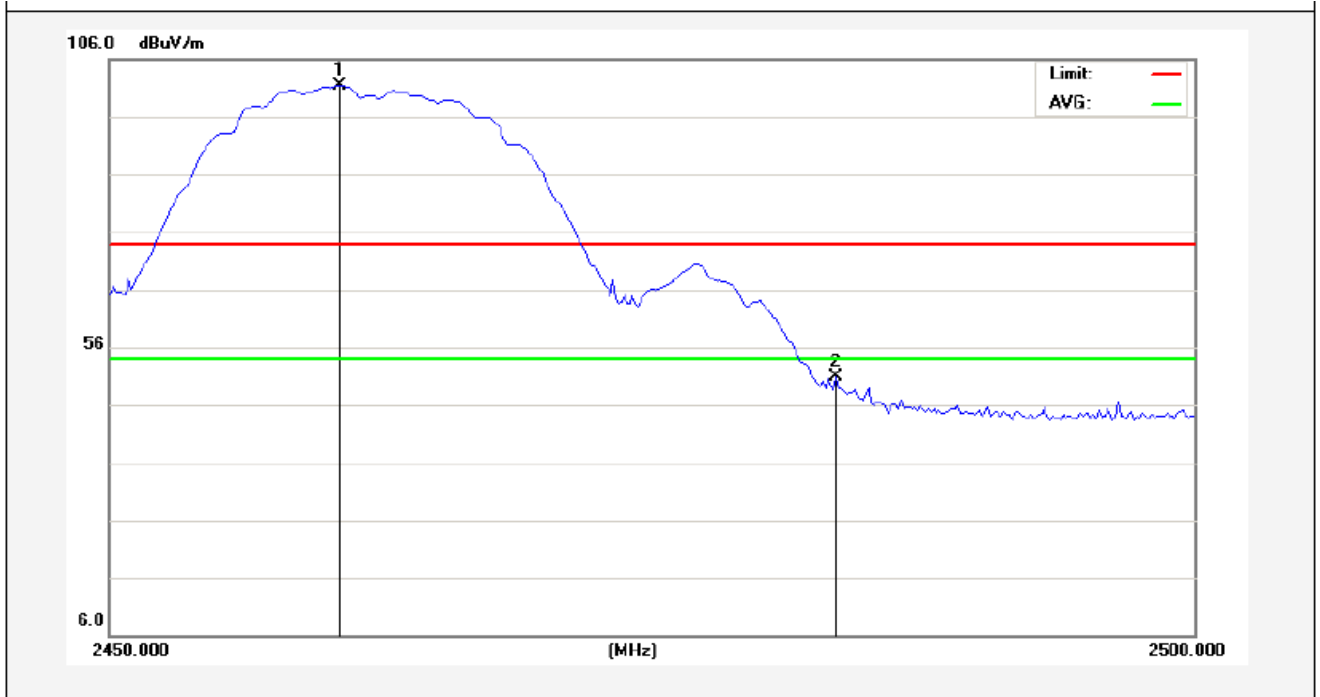

No.	Freq. (MHz)	Reading (dBuV/m)	Factor (dB/m)	Result (dBuV/m)	Limit (dBuV/)	Over Limit (dB)	Detector	Height (cm)	degree (deg)	Remark
1	2460.625	103.74	-2.36	101.38	74.00	27.38	peak			
2	2483.500	53.09	-2.31	50.78	74.00	-23.22	peak			

Anbotek

Horizontal-AV:

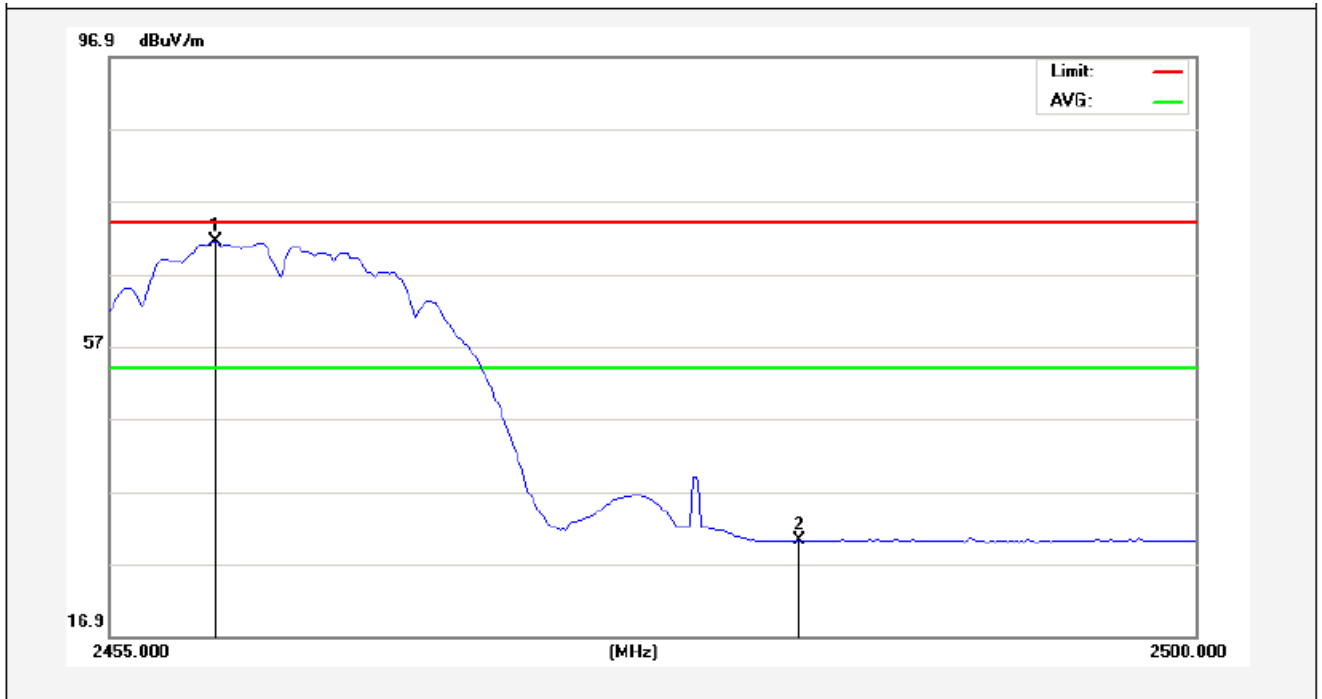

No.	Freq. (MHz)	Reading (dBuV/m)	Factor (dB/m)	Result (dBuV/m)	Limit (dBuV/)	Over Limit (dB)	Detector	Height (cm)	degree (deg)	Remark
1	2459.387	73.67	-2.36	71.31	54.00	17.31	AVG			
2	2483.500	32.48	-2.31	30.17	54.00	-23.83	AVG			

Anbotek

The Worst Mode: 802.11b

2462MHz

Vertical-PEAK:

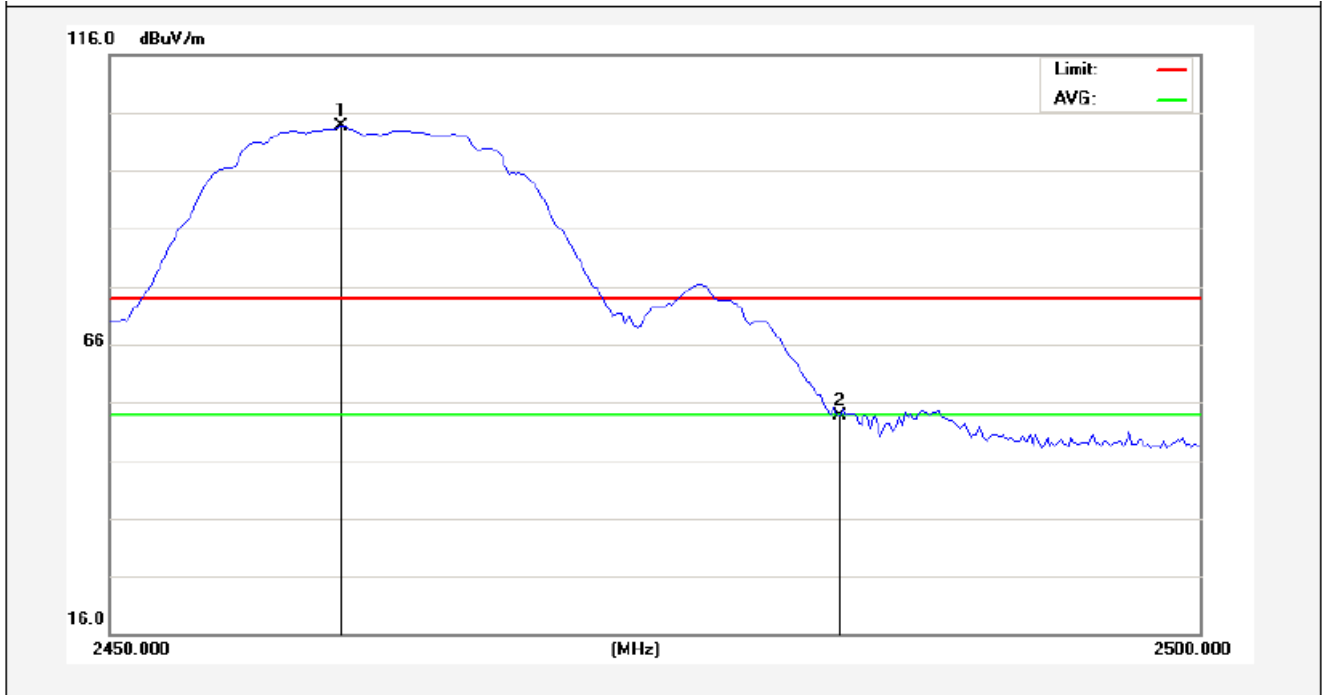

No.	Freq. (MHz)	Reading (dBuV/m)	Factor (dB/m)	Result (dBuV/m)	Limit (dBuV/)	Over Limit (dB)	Detector	Height (cm)	degree (deg)	Remark
1	2460.625	105.88	-2.36	103.52	74.00	29.52	peak			
2	2483.500	55.94	-2.31	53.63	74.00	-20.37	peak			

Anbotek

Vertical-AV:

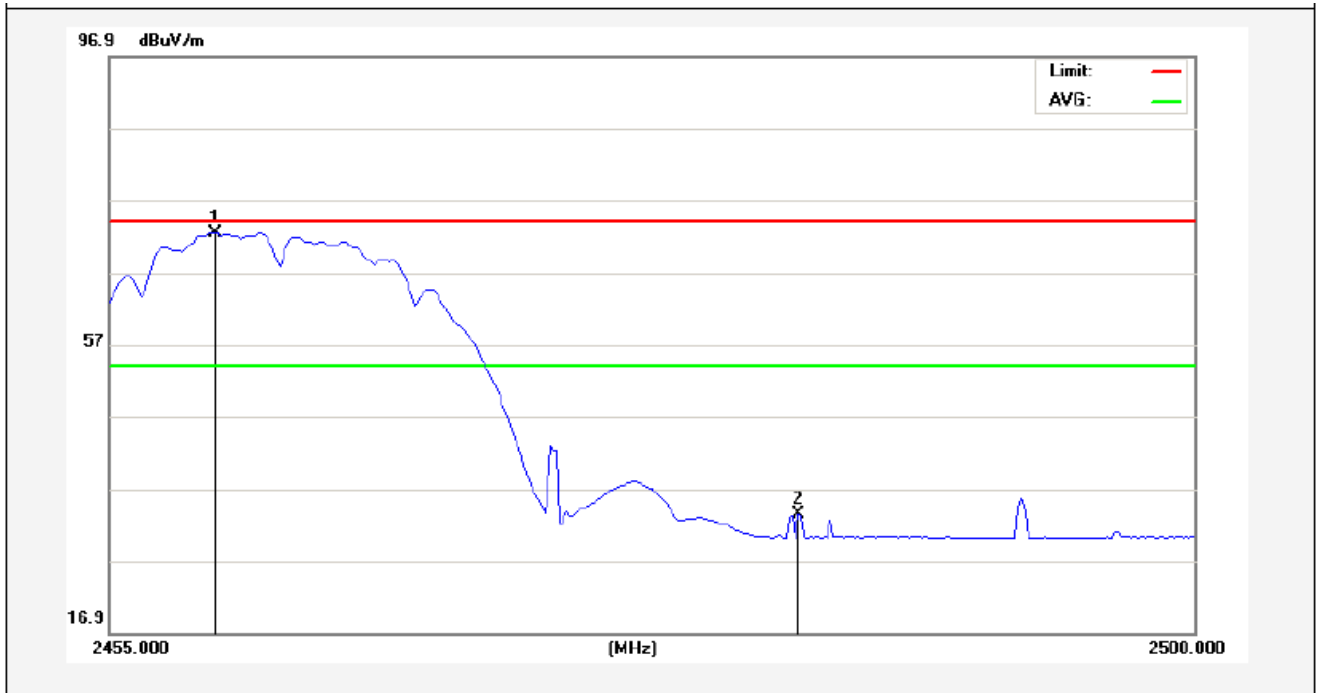

No.	Freq. (MHz)	Reading (dBuV/m)	Factor (dB/m)	Result (dBuV/m)	Limit (dBuV/)	Over Limit (dB)	Detector	Height (cm)	degree (deg)	Remark
1	2459.387	74.83	-2.36	72.47	54.00	18.47	AVG			
2	2483.500	35.75	-2.31	33.44	54.00	-20.56	AVG			

Anbotek

4.5. Peak Power Spectral Density

a. Limit

1. For direct sequence systems, the peak power spectral density conducted from the intentional radiator to the antenna shall not be greater than 8dBm in any 3kHz band during any time interval of continuous transmission.
2. The direct sequence operating of the hybrid system, with the frequency hopping operation turned off, shall comply with the power density requirements of paragraph (d) of this section.

b. Test Procedure

1. Place the EUT on the table and set it in transmitting mode. Remove the antenna from the EUT and then connect a low loss RF cable from the antenna port to the spectrum analyzer.
2. Set the spectrum analyzer as RBW = 3kHz, VBW = 10kHz, Span = 1.5MHz, Sweep=500s
3. Record the max. reading.
4. Repeat the above procedure until the measurements for all frequencies are completed.

c. Test Equipment

Same as the equipment listed in 4.2.

d. Test Setup

See 4.1

e. Test Results

Pass

f. Test Data

Please refer to the following data.

g. Test Plot See the following pages

Test mode: IEEE 802.11b

Channel	Frequency (MHz)	PPSD (dBm/3KHz)	ΣPPSD (dBm/3KHz)	Limit (dBm)	Result
Low	2412	-18.40	-	8.00	Pass
Mid	2437	-17.79	-		Pass
High	2462	-17.24	-		Pass

Test mode: IEEE 802.11g

Channel	Frequency (MHz)	PPSD (dBm)	ΣPPSD (dBm)	Limit (dBm)	Result
Low	2412	-18.40	-	8.00	Pass
Mid	2437	-17.79	-		Pass
High	2462	-17.24	-		Pass

Test mode: IEEE 802.11n (HT20)

Channel	Frequency (MHz)	PPSD (dBm/3KHz)	ΣPPSD (dBm/3KHz)	Limit (dBm)	Result
Low	2412	-18.40	-	8.00	Pass
Mid	2437	-17.79	-		Pass
High	2462	-17.24	-		Pass

Test mode: IEEE 802.11n (HT40)

Channel	Frequency (MHz)	PPSD (dBm/3KHz)	ΣPPSD (dBm/3KHz)	Limit (dBm)	Result
Low	2422	-18.22	-	8.00	Pass
Mid	2437	-18.41	-		Pass
High	2452	-18.89	-		Pass

802.11 b CH--Low

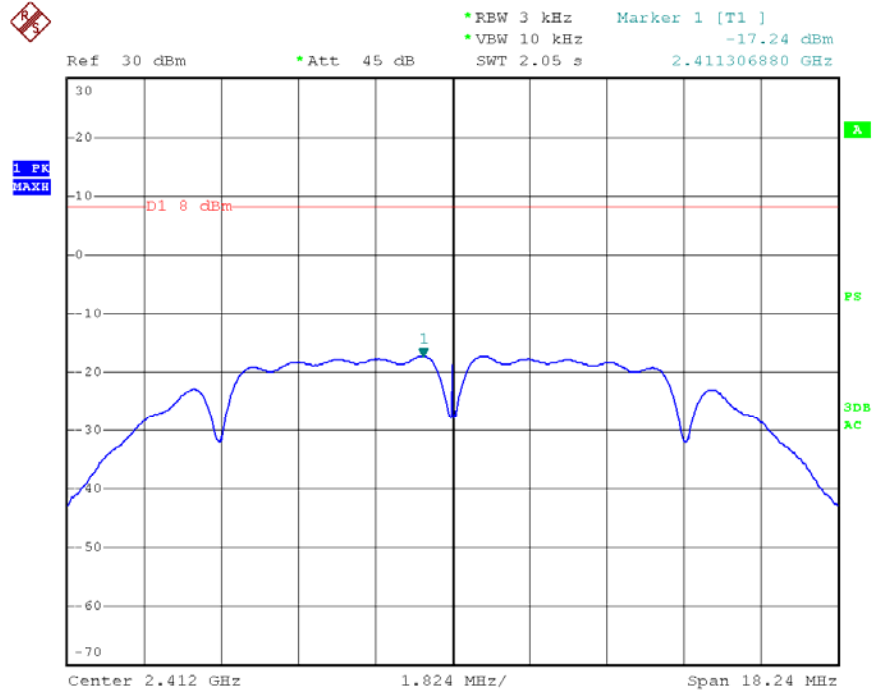

Date: 5.DEC.2013 11:31:51

802.11 b CH--Mid

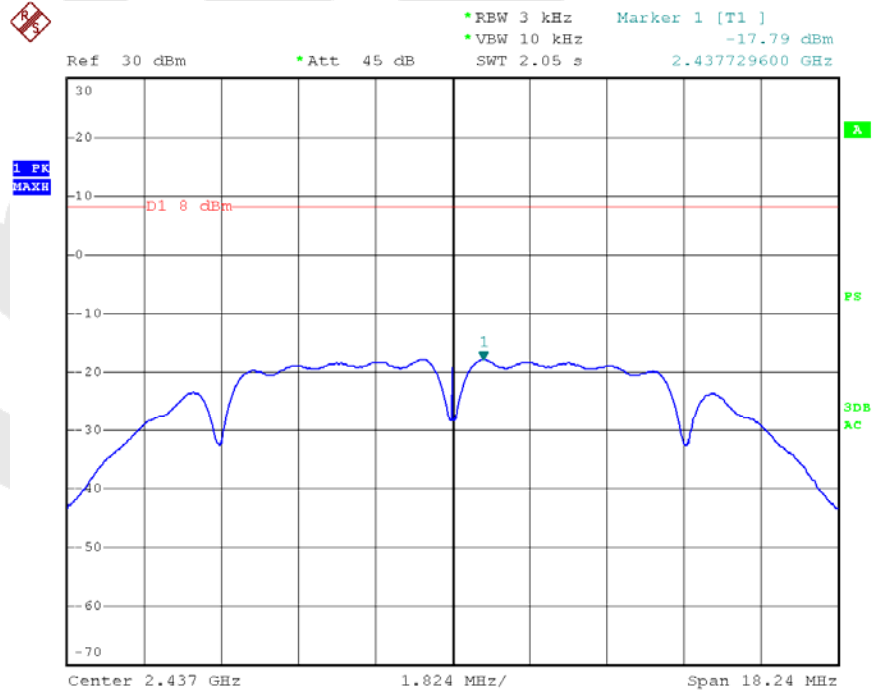

Date: 5.DEC.2013 11:31:04

802.11 b CH--High

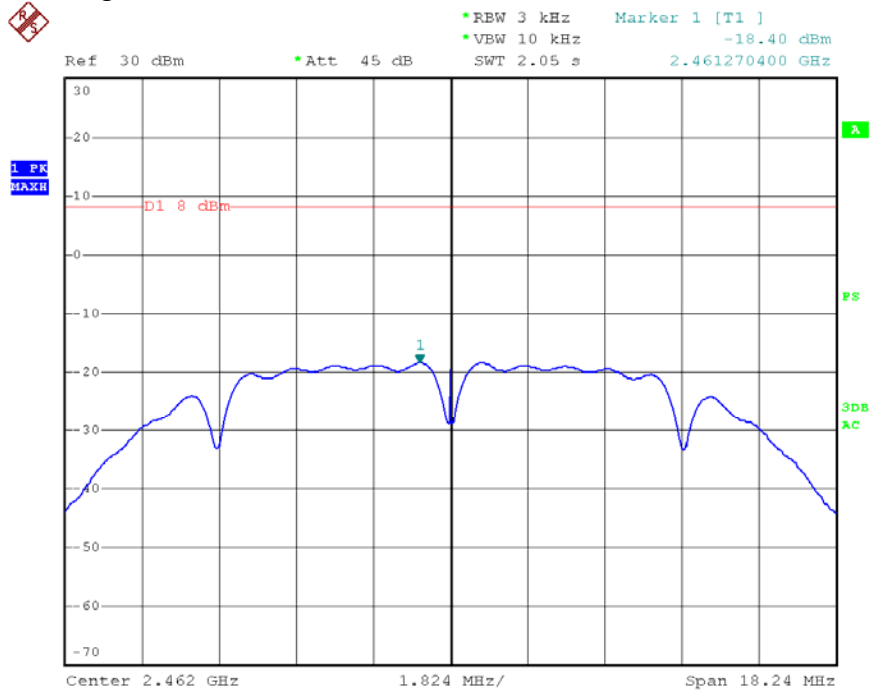

Date: 5.DEC.2013 11:30:08

802.11g CH--Low

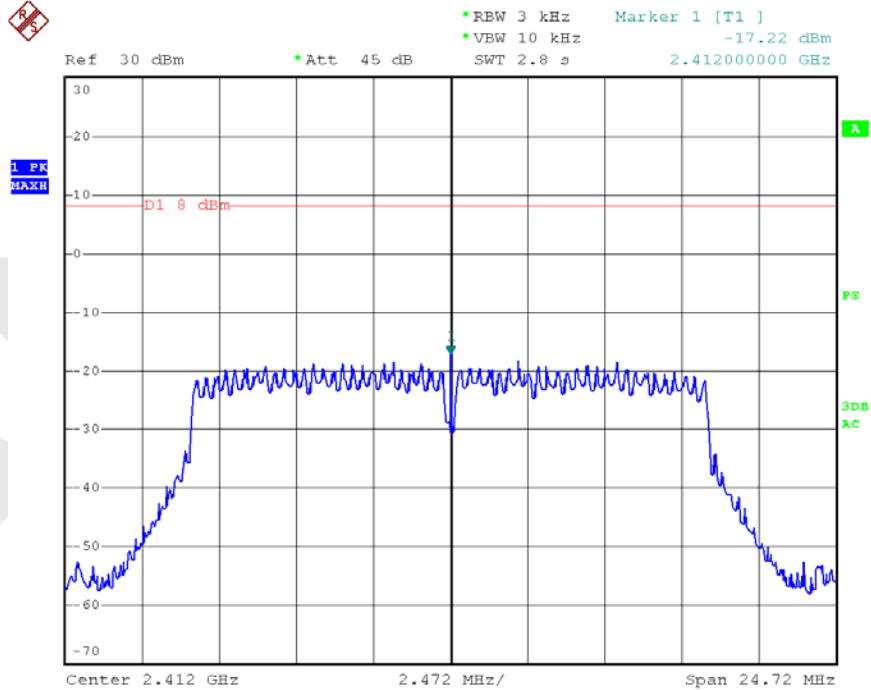

Date: 10.DEC.2013 08:50:58

802.11g CH--Mid

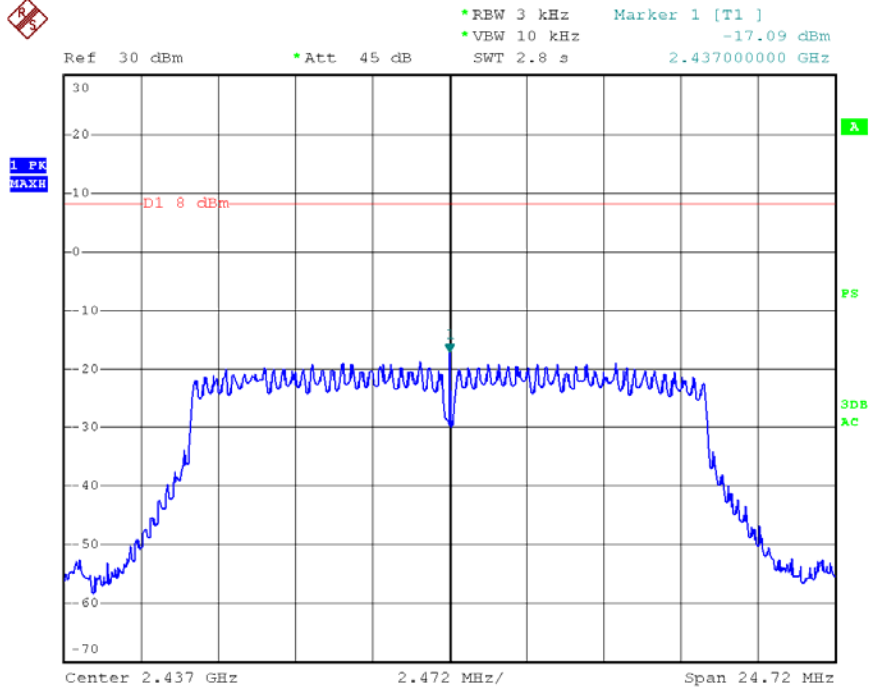

Date: 10.DEC.2013 08:51:26

802.11g CH--High

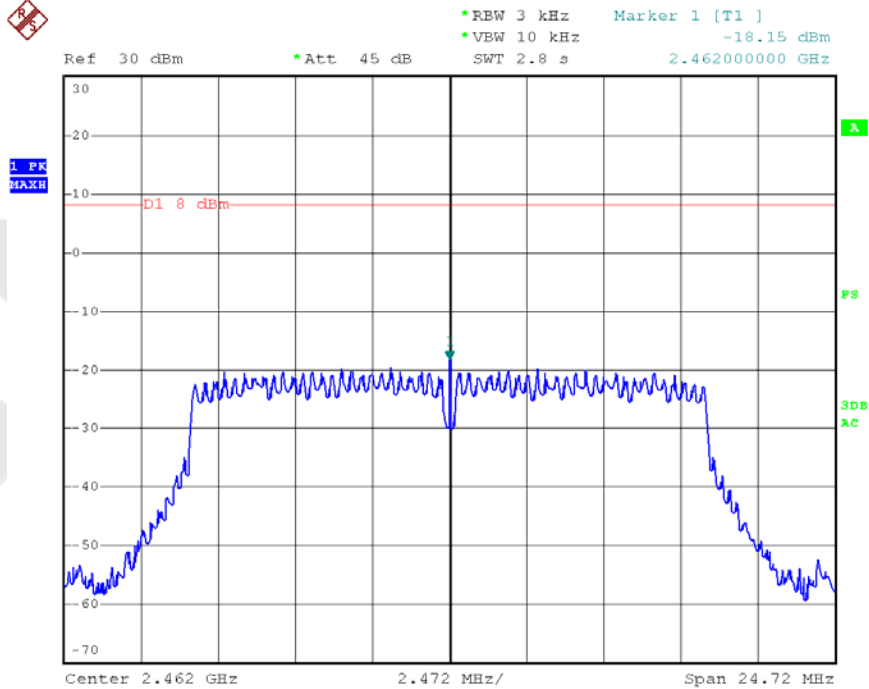

Date: 10.DEC.2013 08:51:51

802.11n (HT20) CH—Low

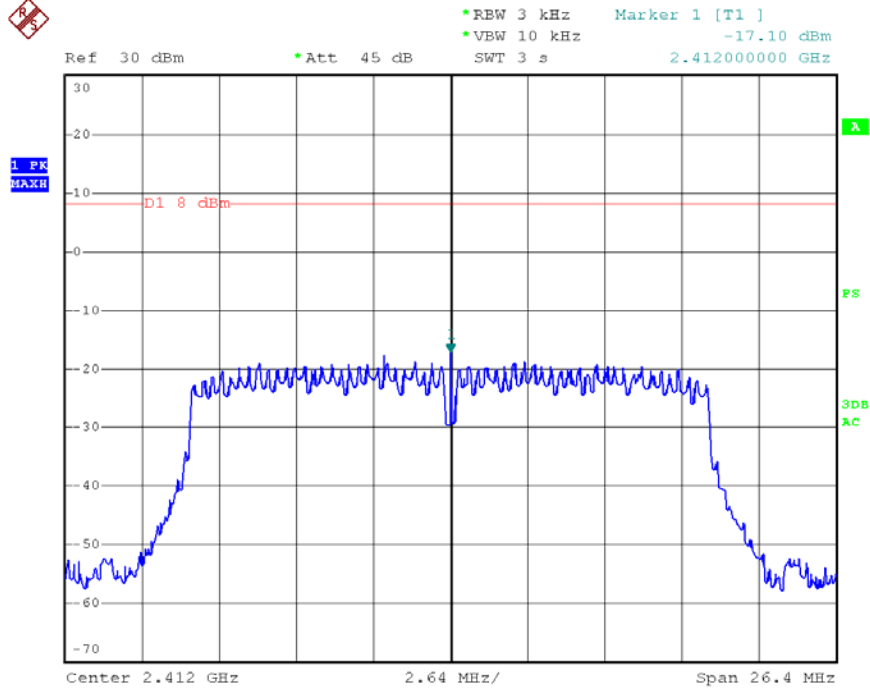

Date: 10.DEC.2013 08:52:34

802.11n (HT20) CH—Mid

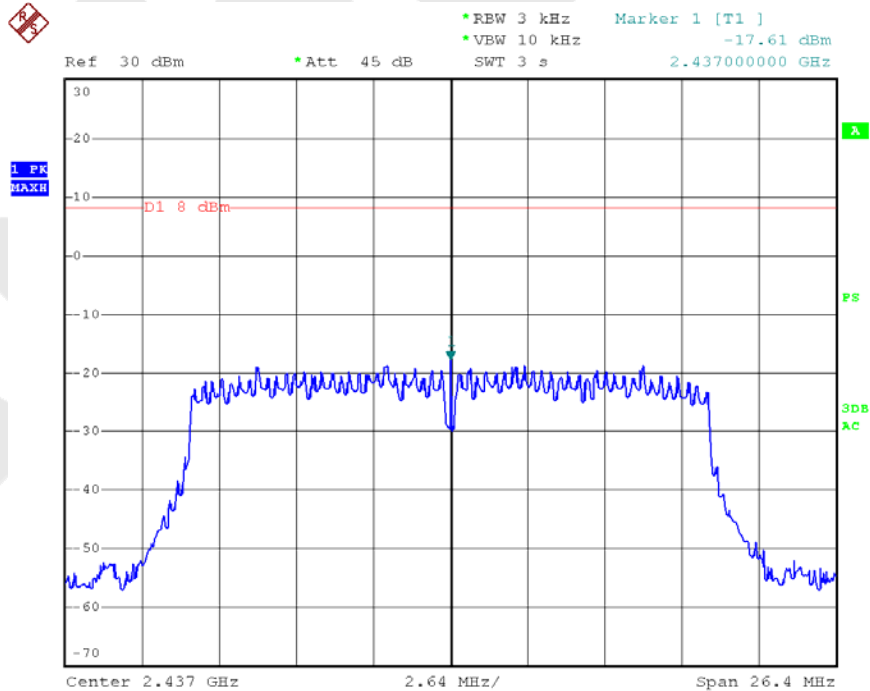

Date: 10.DEC.2013 08:53:10

802.11n (HT20) CH—High

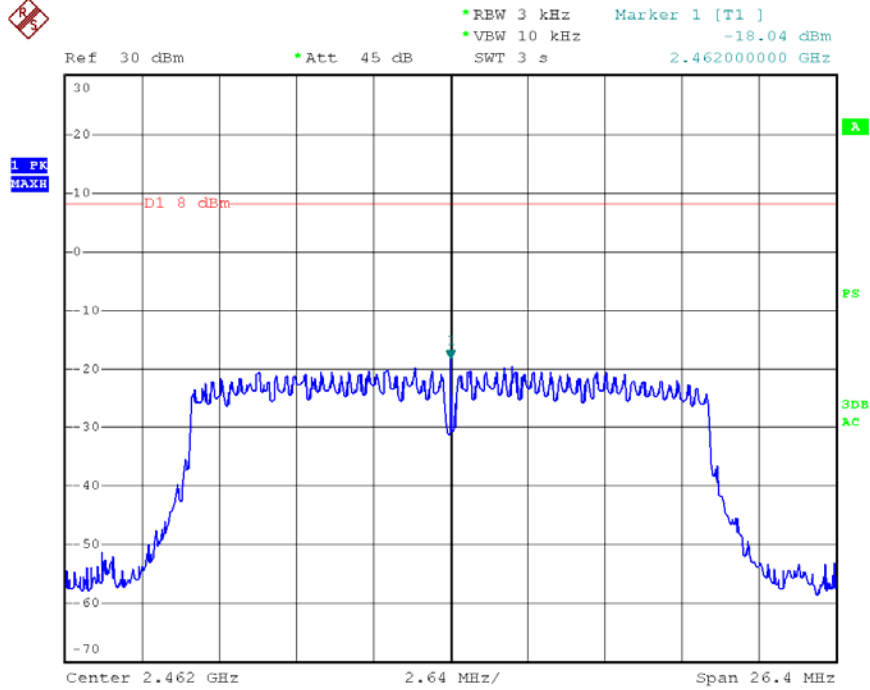

Date: 10.DEC.2013 08:53:50

802.11n (HT40) CH—Low

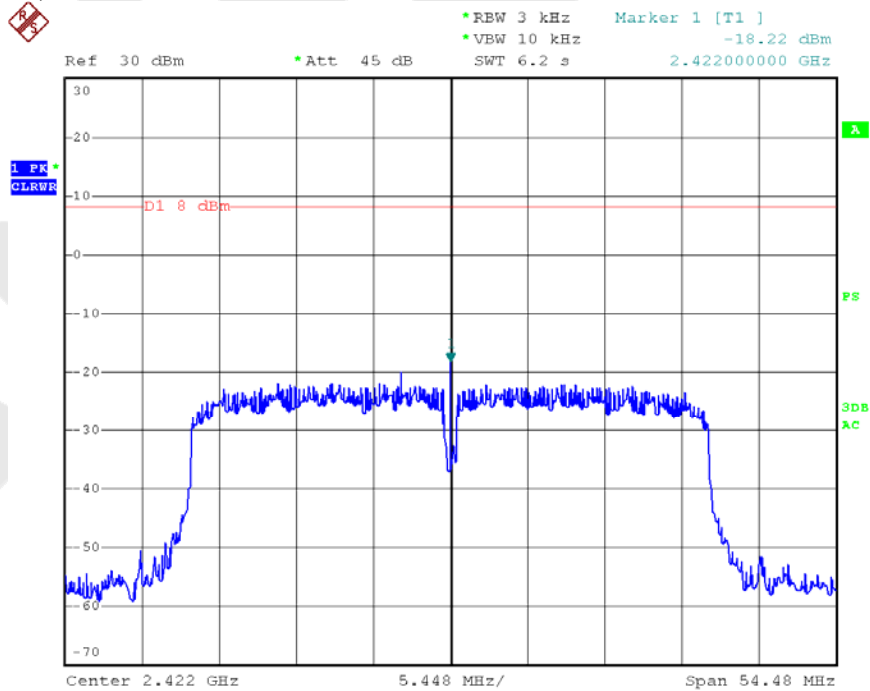

Date: 10.DEC.2013 08:54:42

802.11n (HT40) CH—Mid

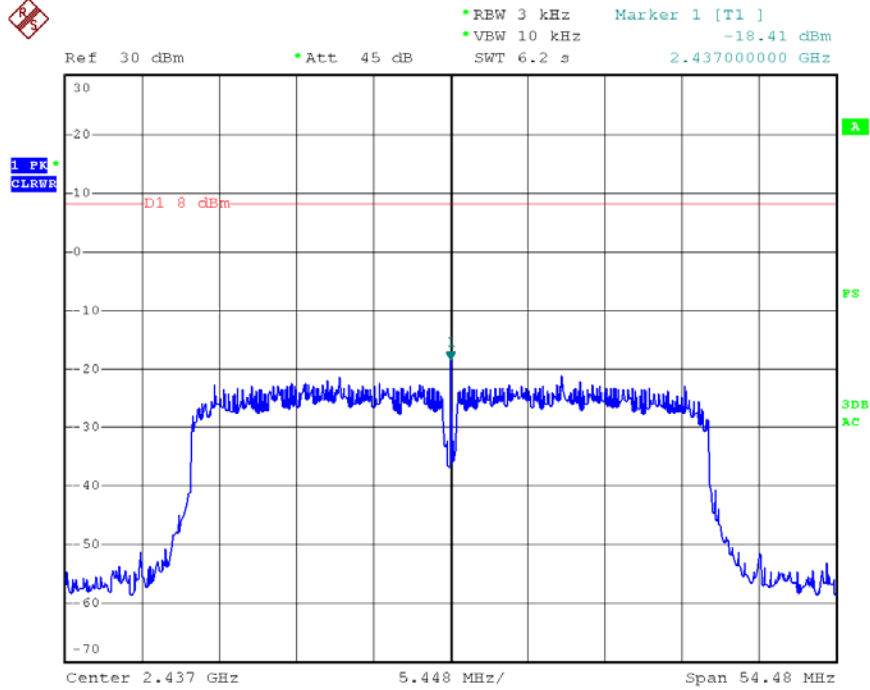

Date: 10.DEC.2013 08:55:17

802.11n (HT40) CH—High

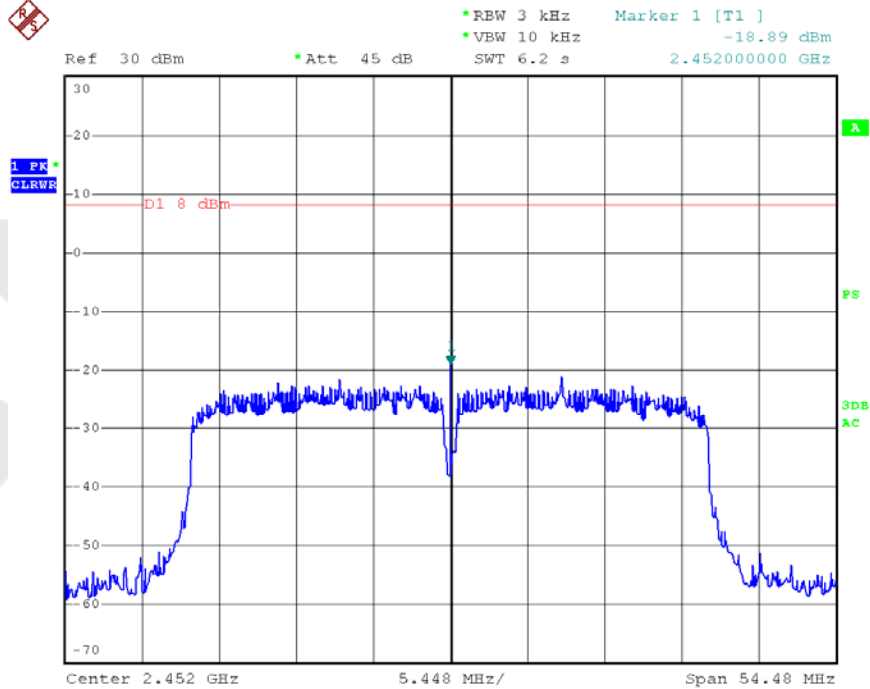

Date: 10.DEC.2013 08:56:06

4.6. Radiated Emissions

4.6.1.1. Test Limits (< 30 MHz)

Frequency (MHz)	Field Strength (microvolts/meter)	Measurement Distance (meter)
0.009-0.490	2400/F(kHz)	300
0.490-1.705	24000/F(kHz)	30
1.705-30.0	30	30

4.6.1.2. Test Limits (≥ 30 MHz)

FIELD STRENGTH of Fundamental: @3M	FIELD STRENGTH of Harmonics	S15.209 30 - 88 MHz	40 dBuV/m
902-928 MHz		88 - 216 MHz	43.5
2.4-2.4835 GHz		216 - 960 MHz	46
94 dBμV/m @3m	54 dBμV/m @3m	ABOVE 960 MHz	54dBuV/m

In any 100 kHz bandwidth outside the frequency band in which the spread spectrum or digitally modulated intentional radiator is operating, the radio frequency power that is produced by the intentional radiator shall be at least 20 dB below that in the 100 kHz bandwidth within the band that contains the highest level of the desired power, based on either an RF conducted or a radiated measurement. Attenuation below the general limits specified in Section 15.209(a) is not required. In addition, radiated emissions which fall in the restricted bands, as defined in Section 15.205(a), must also comply with the radiated emission limits specified in Section 15.209(a) (see Section 15.205(c)).

Test Equipment

Item	Equipment	Manufacturer	Model No.	Serial No.	Last Cal.	Cal. Interval
1.	Preamplifier	Instruments corporation	EMC011830	980100	Aug. 09, 2013	1 Year
2.	EMI Test Receiver	Rohde & Schwarz	ESPI	101604	Apr. 23, 2013	1 Year
3.	Double Ridged Horn Antenna	Instruments corporation	GTH-0118	351600	Aug. 09, 2013	3 Year
4.	Bilog Broadband Antenna	Schwarzbeck	VULB9163	VULB 9163-289	Apr. 23, 2013	3 Year
5.	Pre-amplifier	SONOMA	310N	186860	Apr. 23, 2013	1 Year
6.	EMI Test Software EZ-EMC	SHURPLE	N/A	N/A	N/A	N/A

4.6.2. Test Configuration:

4.6.2.1. 9k to 30MHz emissions:

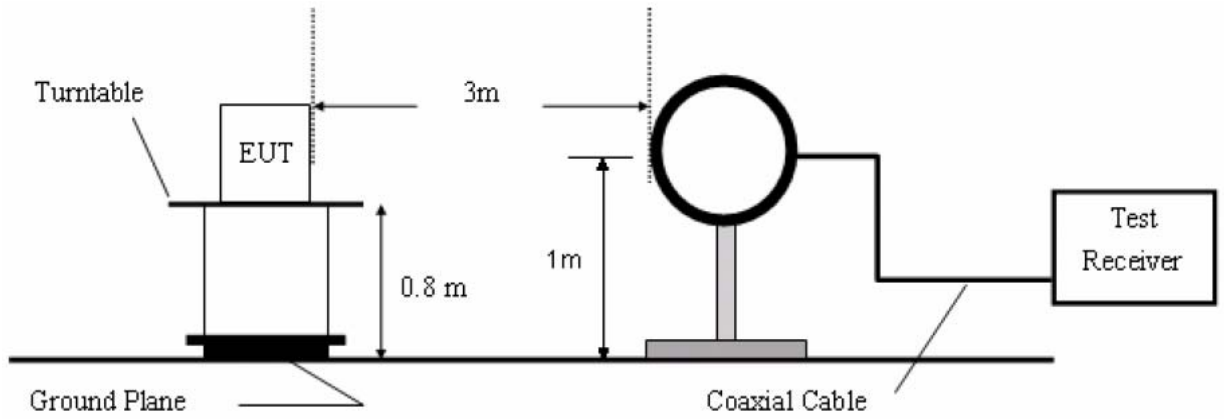

4.6.2.2. 30M to 1G emissions:

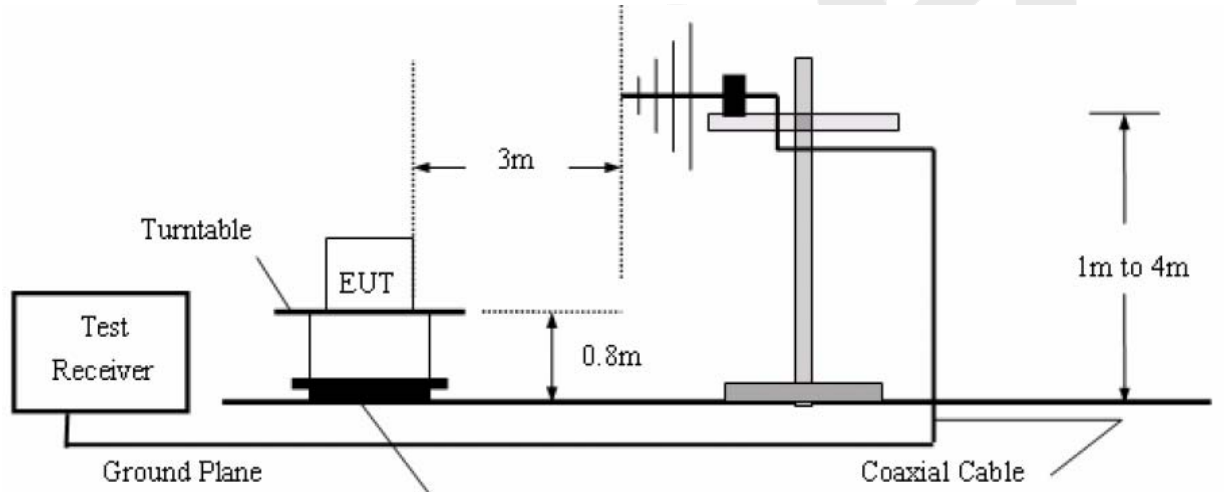

4.6.2.3. 1G to 40G emissions:

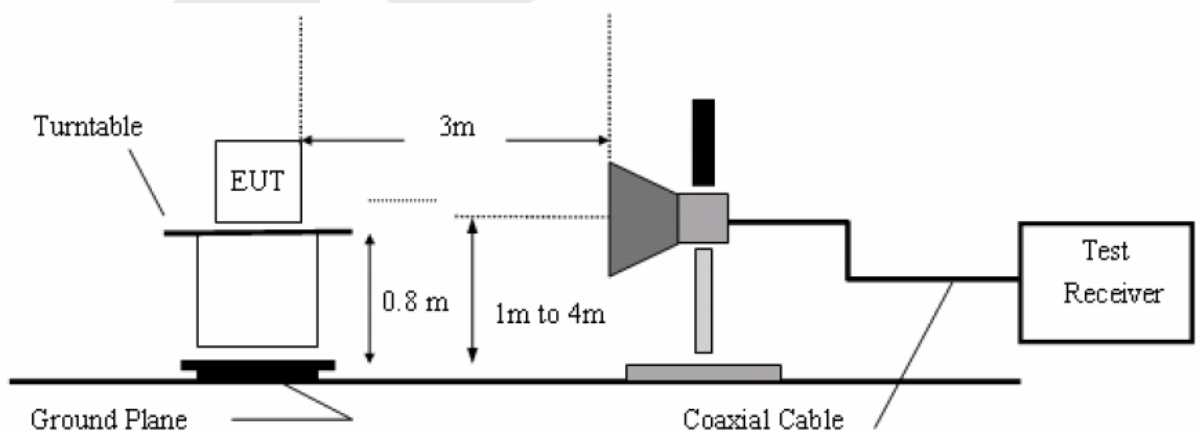

4.6.3. Test Procedure

The EUT is placed on a turn table which is 0.8 meter high above the ground. The turn table can rotate 360 degrees to determine the position of the maximum emission level. The EUT is set 3 meters away from the receiving antenna which is mounted on a antenna tower. The antenna can be moved up and down from 1 to 4 meters to find out the maximum emission level. Both horizontal and vertical polarization of the antenna are set on test.

Measurements are made on 9KHz to 30MHz and 30MHz to 26GHz range with the transmitter set to the lowest, middle, and highest channels.

All readings from 30MHz to 1GHz are quasi-peak values with a resolution bandwidth of 120kHz. All reading are above 1GHz, peak & average values with a resolution bandwidth of 1MHz.

The EUT is tested in 9*6*6 Chamber.

The test results are listed in Section 4.6.4.

4.6.4. Test Results

Please refer to the following pages.

Job No.:	AT1311755F	Polarization:	Horizontal
Standard:	(RE)FCC PART15 C_3m	Power Source:	AC 120V/60Hz for adapter
Test item:	Radiation Test	Test By:	Kebo Zhang
Temp.(C)/Hum.(%RH):	24.3(C)/55%RH	Distance:	3m
Note:	On		

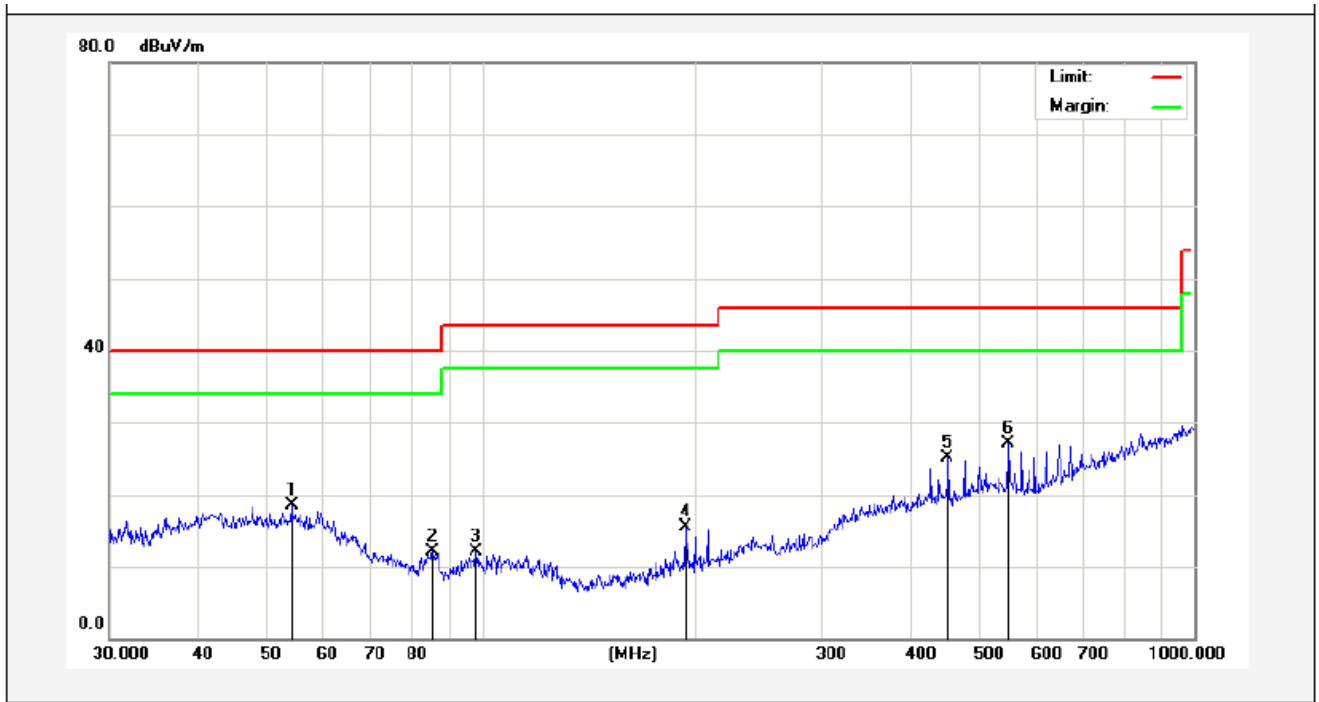

No.	Freq. (MHz)	Reading (dBuV/m)	Factor (dB/m)	Result (dBuV/m)	Limit (dBuV/)	Over Limit (dB)	Detector	Height (cm)	degree (deg)	Remark
1	54.0711	33.30	-14.87	18.43	40.00	-21.57	peak			
2	85.2980	32.60	-20.49	12.11	40.00	-27.89	peak			
3	98.1419	33.06	-20.86	12.20	43.50	-31.30	peak			
4	193.0945	36.49	-20.91	15.58	43.50	-27.92	peak			
5	451.1350	37.25	-12.15	25.10	46.00	-20.90	peak			
6	549.0195	38.24	-11.08	27.16	46.00	-18.84	peak			



Job No.:	AT1311755F	Polarization:	Vertical
Standard:	(RE)FCC PART15 C _3m	Power Source:	AC 120V/60Hz for adapter
Test item:	Radiation Test	Test By:	Kebo Zhang
Temp.(C)/Hum.(%RH):	24.3(C)/55%RH	Distance:	3m
Note:	On		

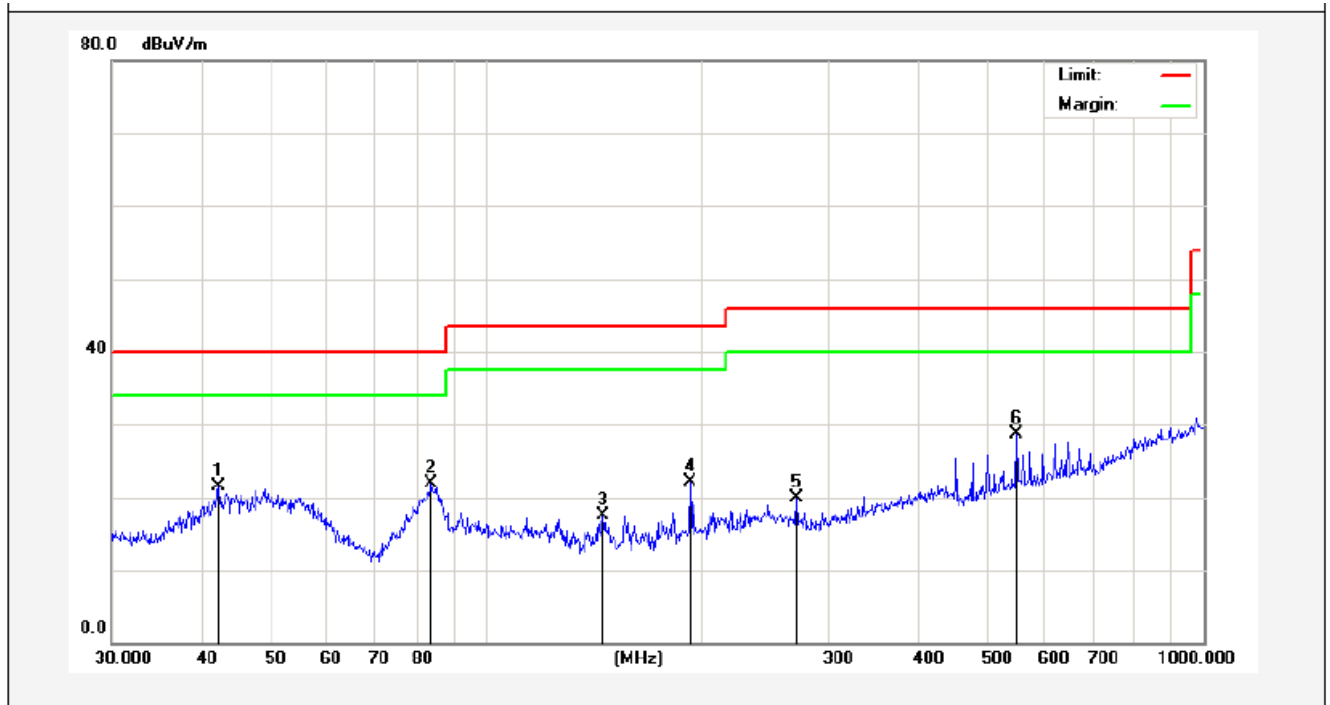

No.	Freq. (MHz)	Reading (dBuV/m)	Factor (dB/m)	Result (dBuV/m)	Limit (dBuV/)	Over Limit (dB)	Detector	Height (cm)	degree (deg)	Remark
1	42.3022	35.79	-14.35	21.44	40.00	-18.56	peak			
2	83.8156	40.69	-18.73	21.96	40.00	-18.04	peak			
3	145.3506	35.95	-18.41	17.54	43.50	-25.96	peak			
4	192.4186	37.93	-15.91	22.02	43.50	-21.48	peak			
5	270.3748	34.47	-14.63	19.84	46.00	-26.16	peak			
6	549.0195	38.78	-10.10	28.68	46.00	-17.32	peak			

Job No.:	AT1311755F	Polarization:	Horizontal
Standard:	(RE)FCC PART15 C_3m	Power Source:	AC 120V/60Hz for adapter
Test item:	Radiation Test	Test By:	Rock Zeng
Temp.(C)/Hum.(%RH):	24.3(C)/55%RH	Distance:	3m
Note:	802.11b(2412MHz)		

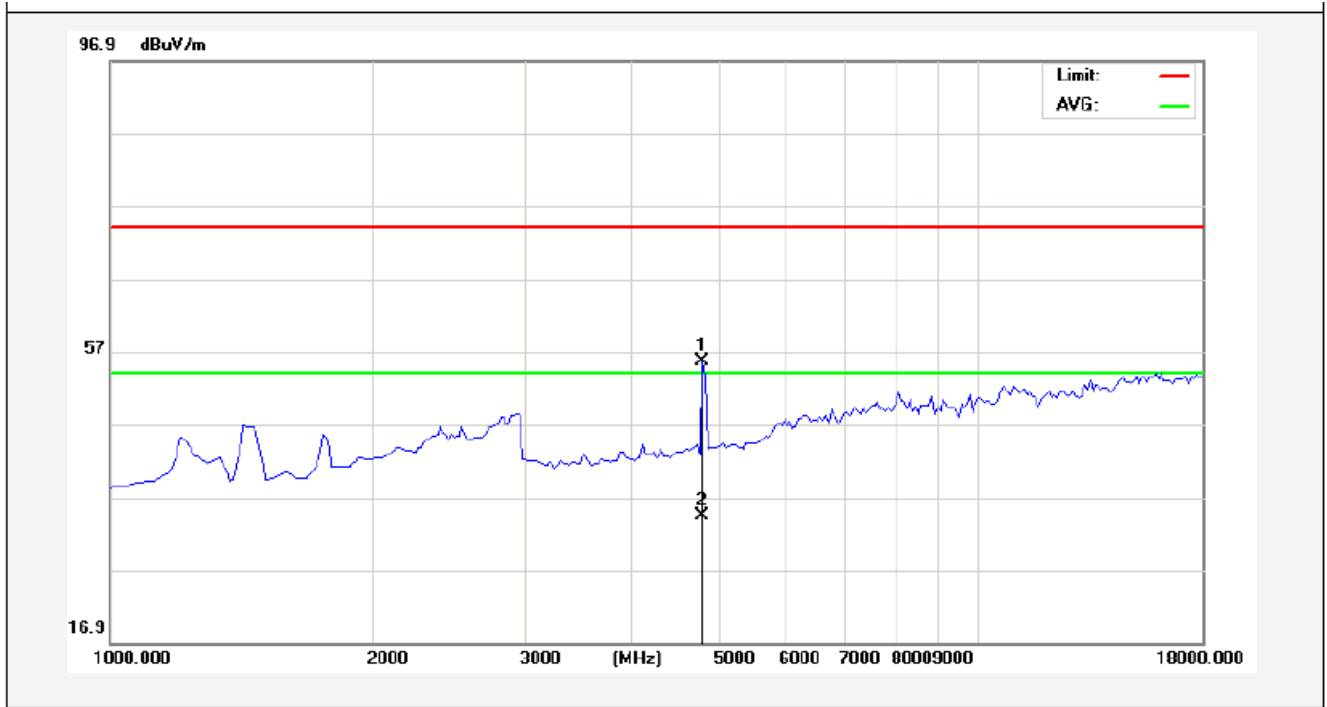

No.	Freq. (MHz)	Reading (dBuV/m)	Factor (dB/m)	Result (dBuV/m)	Limit (dBuV/)	Over Limit (dB)	Detector	Height (cm)	degree (deg)	Remark
1	4825.000	52.28	3.34	55.62	74.00	-18.38	peak			
2	4825.000	31.02	3.34	34.36	54.00	-19.64	AVG			

AEM

Job No.:	AT1311755F	Polarization:	Vertical
Standard:	(RE)FCC PART15 C_3m	Power Source:	AC 120V/60Hz for adapter
Test item:	Radiation Test	Test By:	Rock Zeng
Temp.(C)/Hum.(%RH):	24.3(C)/55%RH	Distance:	3m
Note:	802.11b(2412MHz)		

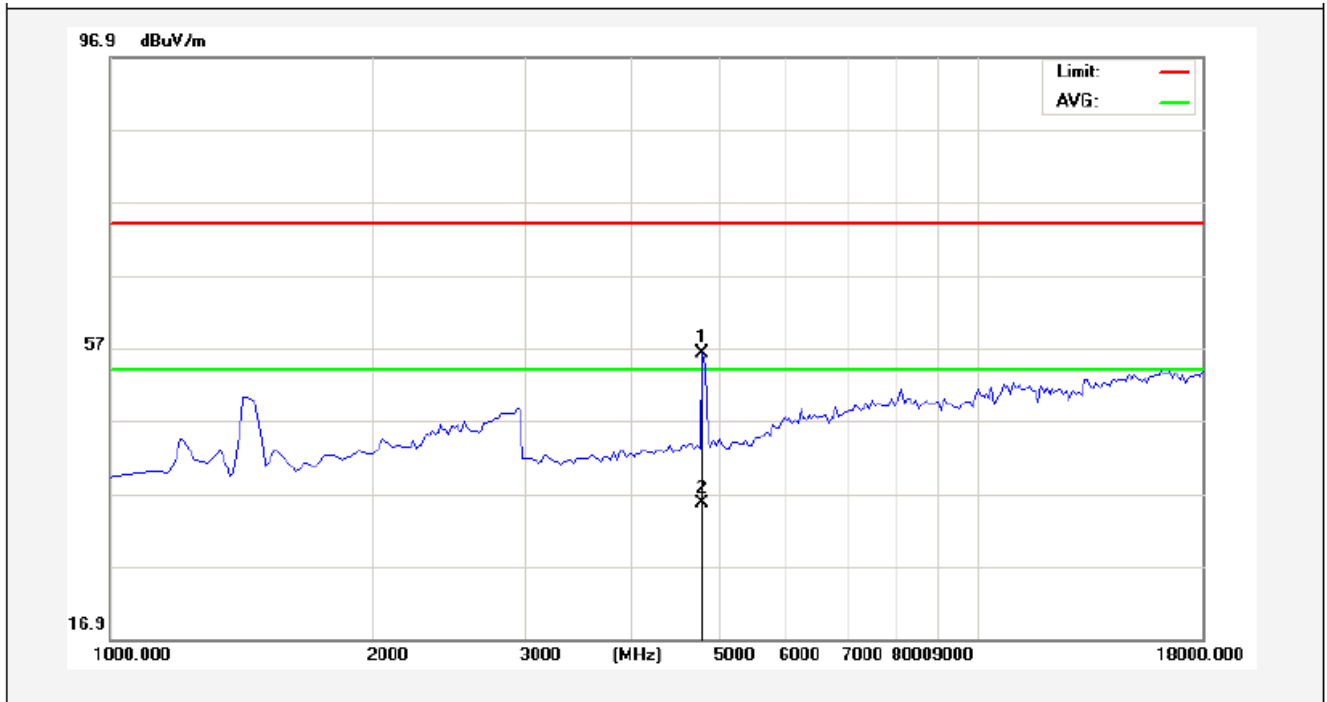

No.	Freq. (MHz)	Reading (dBuV/m)	Factor (dB/m)	Result (dBuV/m)	Limit (dBuV/)	Over Limit (dB)	Detector	Height (cm)	degree (deg)	Remark
1	4825.000	52.96	3.34	56.30	74.00	-17.70	peak			
2	4825.000	32.27	3.34	35.61	54.00	-18.39	AVG			

AM

Job No.:	AT1311755F	Polarization:	Horizontal
Standard:	(RE)FCC PART15 C_3m	Power Source:	AC 120V/60Hz for adapter
Test item:	Radiation Test	Test By:	Rock Zeng
Temp.(C)/Hum.(%RH):	24.3(C)/55%RH	Distance:	3m
Note:	802.11b(2437MHz)		

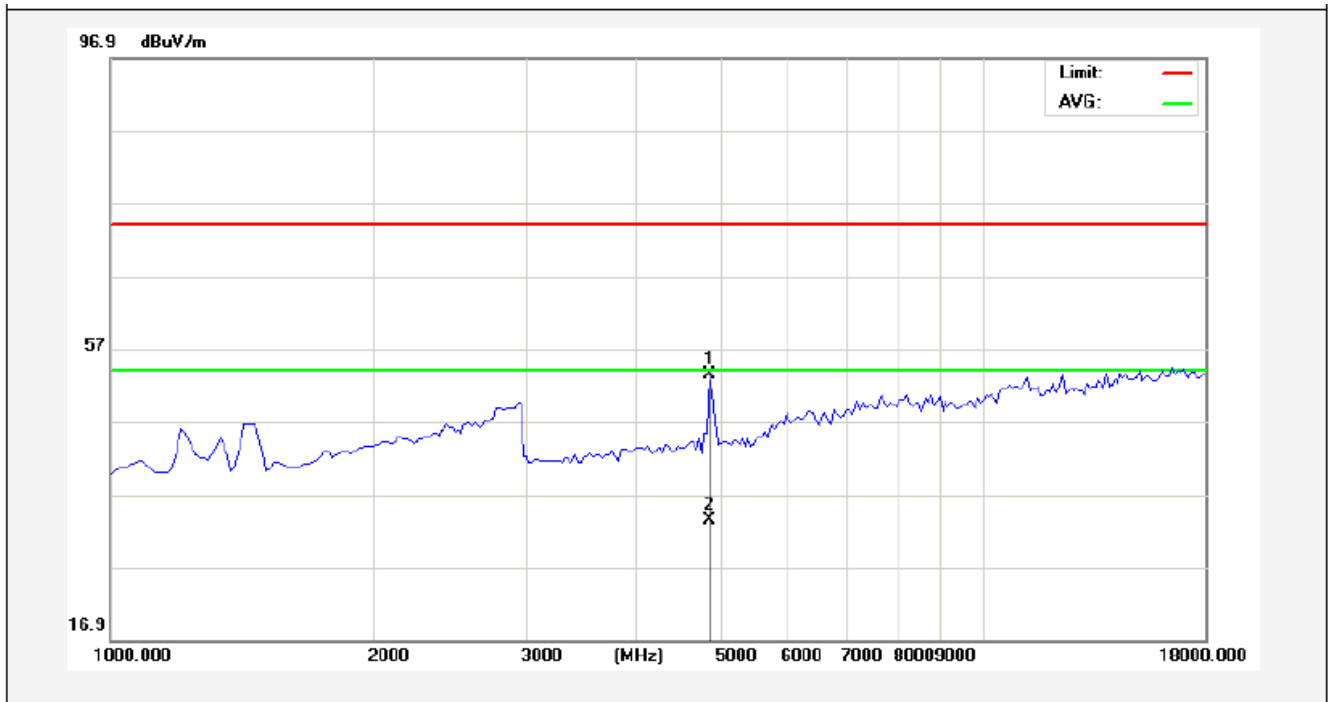

No.	Freq. (MHz)	Reading (dBuV/m)	Factor (dB/m)	Result (dBuV/m)	Limit (dBuV/)	Over Limit (dB)	Detector	Height (cm)	degree (deg)	Remark
1	4867.500	49.93	3.41	53.34	74.00	-20.66	peak			
2	4867.500	30.07	3.41	33.48	54.00	-20.52	AVG			

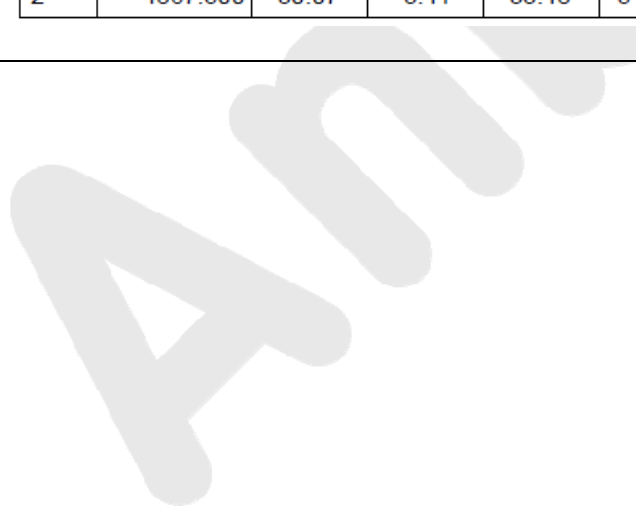

Job No.:	AT1311755F	Polarization:	Vertical
Standard:	(RE)FCC PART15 C_3m	Power Source:	AC 120V/60Hz for adapter
Test item:	Radiation Test	Test By:	Rock Zeng
Temp.(C)/Hum.(%RH):	24.3(C)/55%RH	Distance:	3m
Note:	802.11b(2437MHz)		

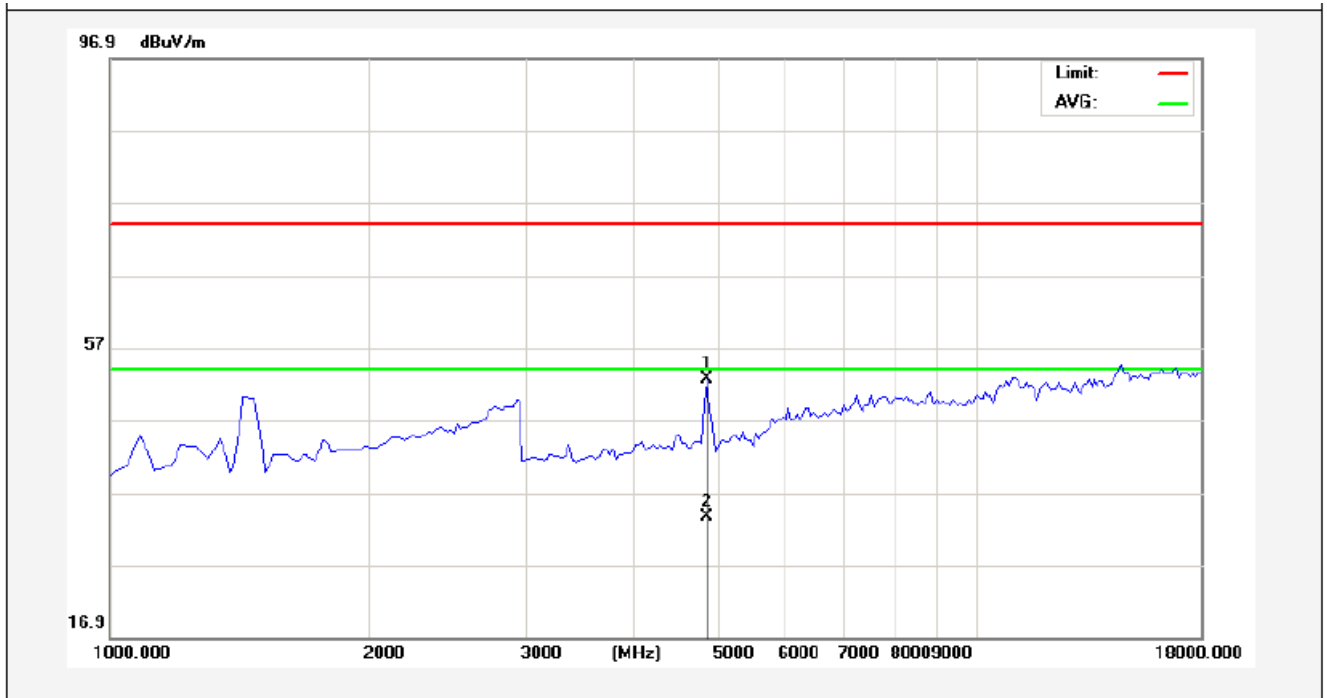

No.	Freq. (MHz)	Reading (dBuV/m)	Factor (dB/m)	Result (dBuV/m)	Limit (dBuV/)	Over Limit (dB)	Detector	Height (cm)	degree (deg)	Remark
1	4867.500	49.14	3.41	52.55	74.00	-21.45	peak			
2	4867.500	30.20	3.41	33.61	54.00	-20.39	AVG			

AEM

Job No.:	AT1311755F	Polarization:	Horizontal
Standard:	(RE)FCC PART15 C_3m	Power Source:	AC 120V/60Hz for adapter
Test item:	Radiation Test	Test By:	Rock Zeng
Temp.(C)/Hum.(%RH):	24.3(C)/55%RH	Distance:	3m
Note:	802.11b(2462MHz)		

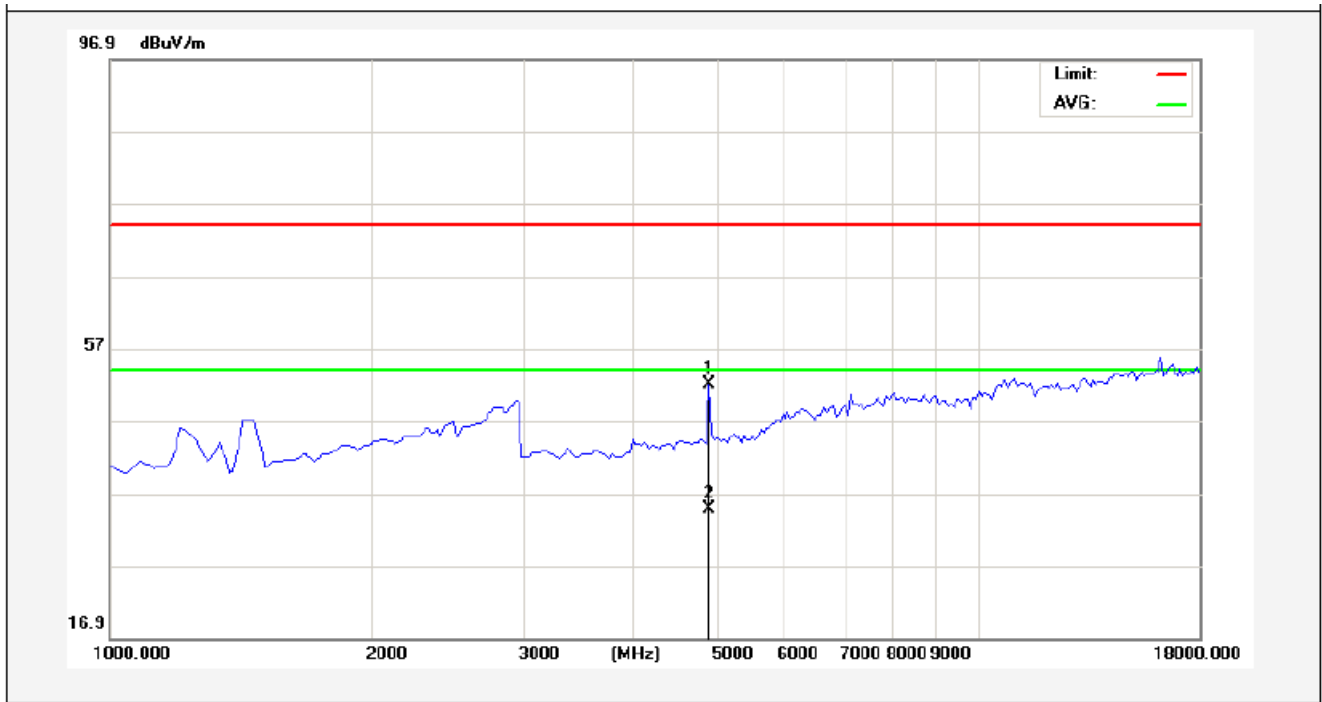

No.	Freq. (MHz)	Reading (dBuV/m)	Factor (dB/m)	Result (dBuV/m)	Limit (dBuV/)	Over Limit (dB)	Detector	Height (cm)	degree (deg)	Remark
1	4910.000	48.56	3.49	52.05	74.00	-21.95	peak			
2	4910.000	31.33	3.49	34.82	54.00	-19.18	AVG			

AEM

Job No.:	AT1311755F	Polarization:	Vertical
Standard:	(RE)FCC PART15 C_3m	Power Source:	AC 120V/60Hz for adapter
Test item:	Radiation Test	Test By:	Rock Zeng
Temp.(C)/Hum.(%RH):	24.3(C)/55%RH	Distance:	3m
Note:	802.11b(2462MHz)		

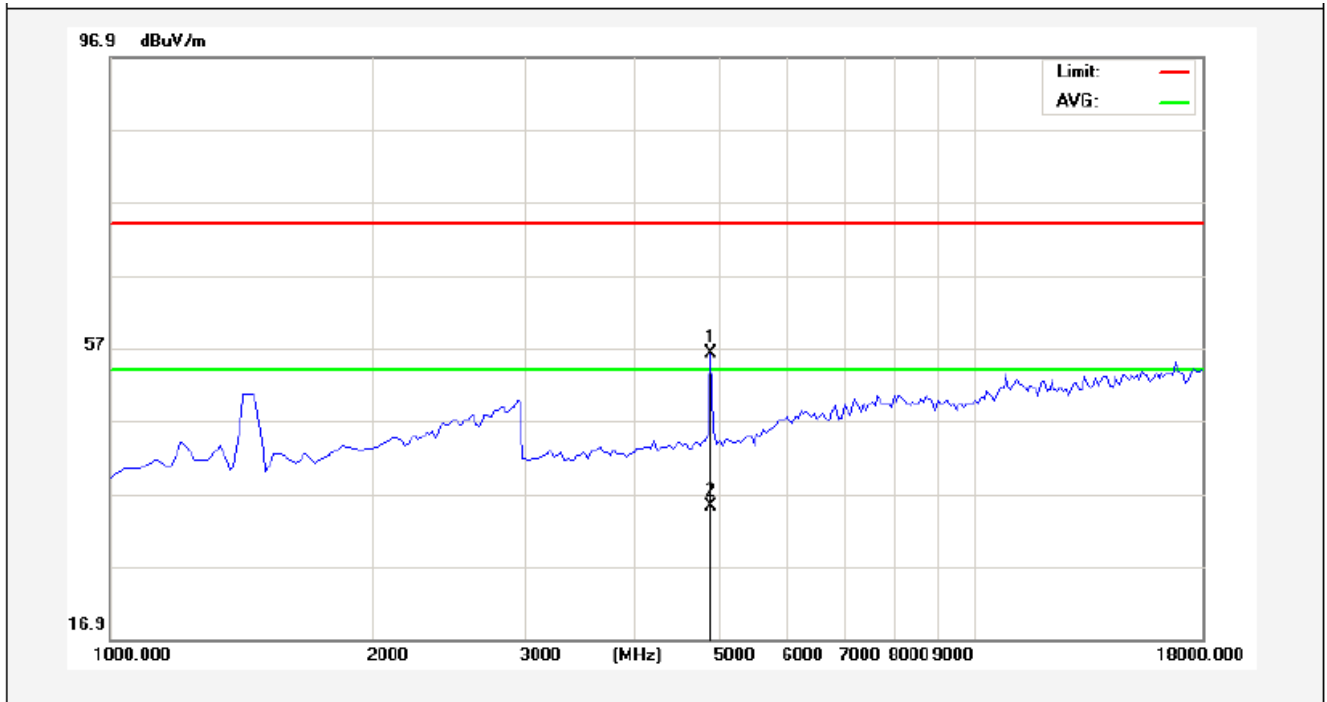

No.	Freq. (MHz)	Reading (dBuV/m)	Factor (dB/m)	Result (dBuV/m)	Limit (dBuV/)	Over Limit (dB)	Detector	Height (cm)	degree (deg)	Remark
1	4910.000	52.75	3.49	56.24	74.00	-17.76	peak			
2	4910.000	31.70	3.49	35.19	54.00	-18.81	AVG			

AEM

5. PHOTOGRAPH

5.1. Photo of Conducted Emission Measurement



5.2. Photo of Radiation Emission Test

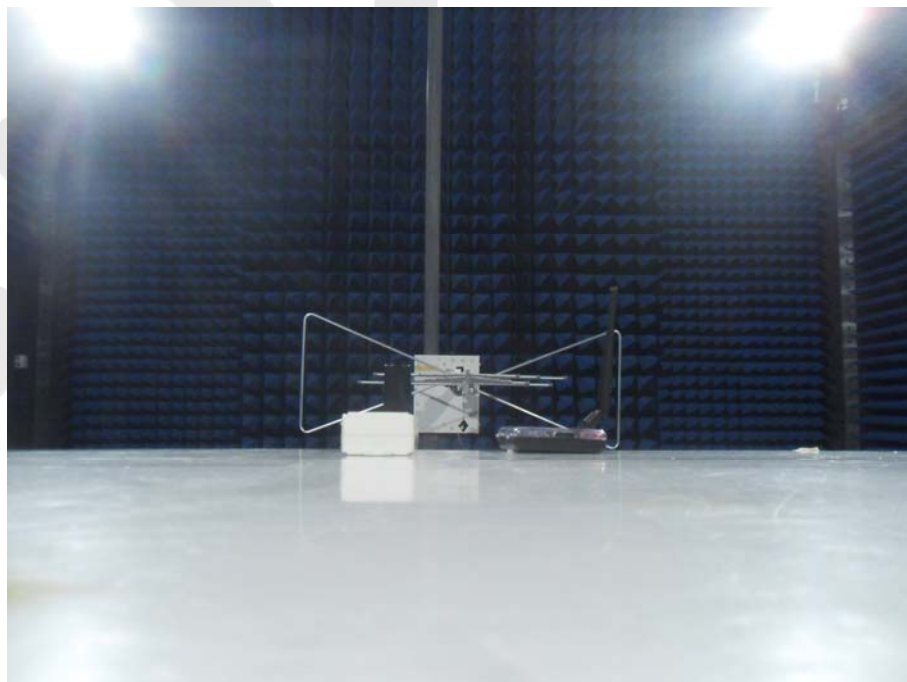

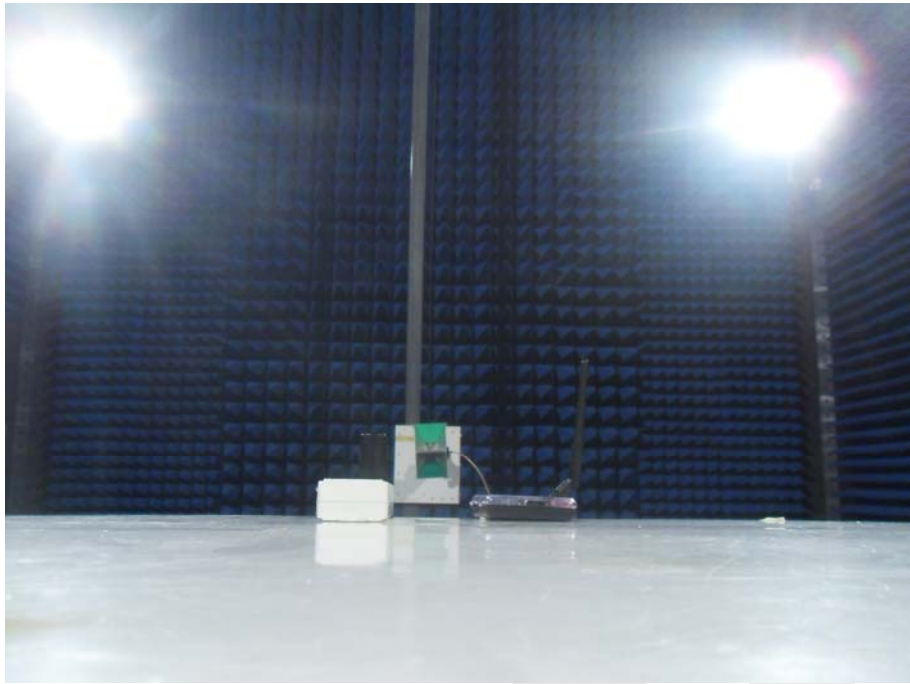

Anbotek

Appendix I (External Photos)

Figure 1
The Overall View



Figure 2
The Overall-Front View

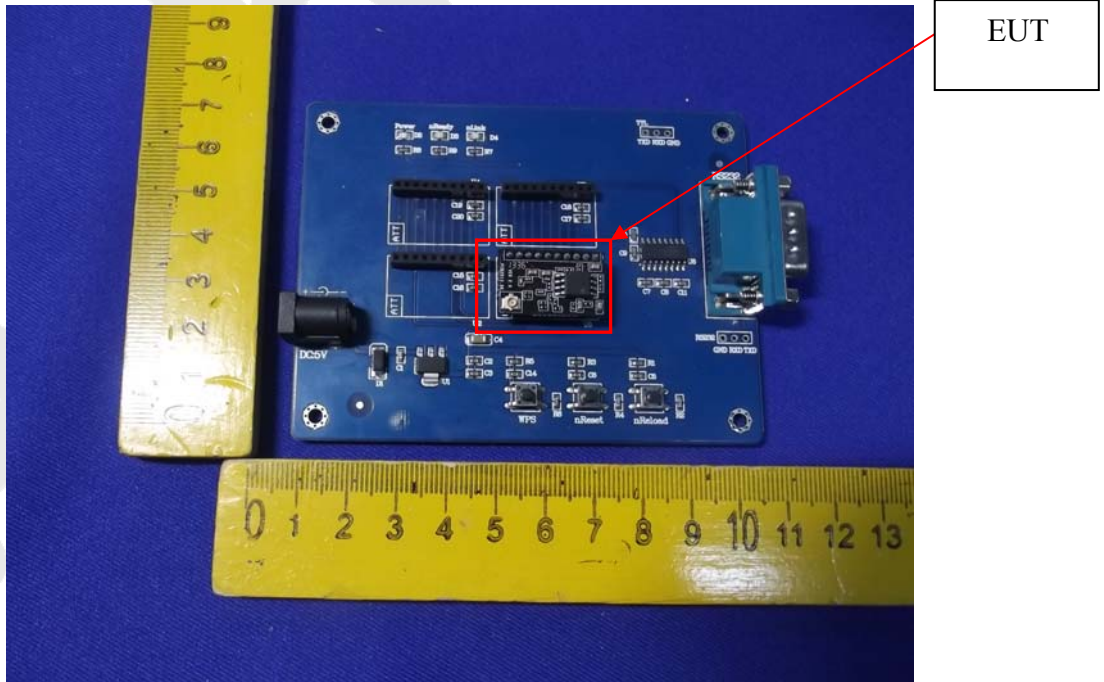

Figure 3
The EUT-Front View

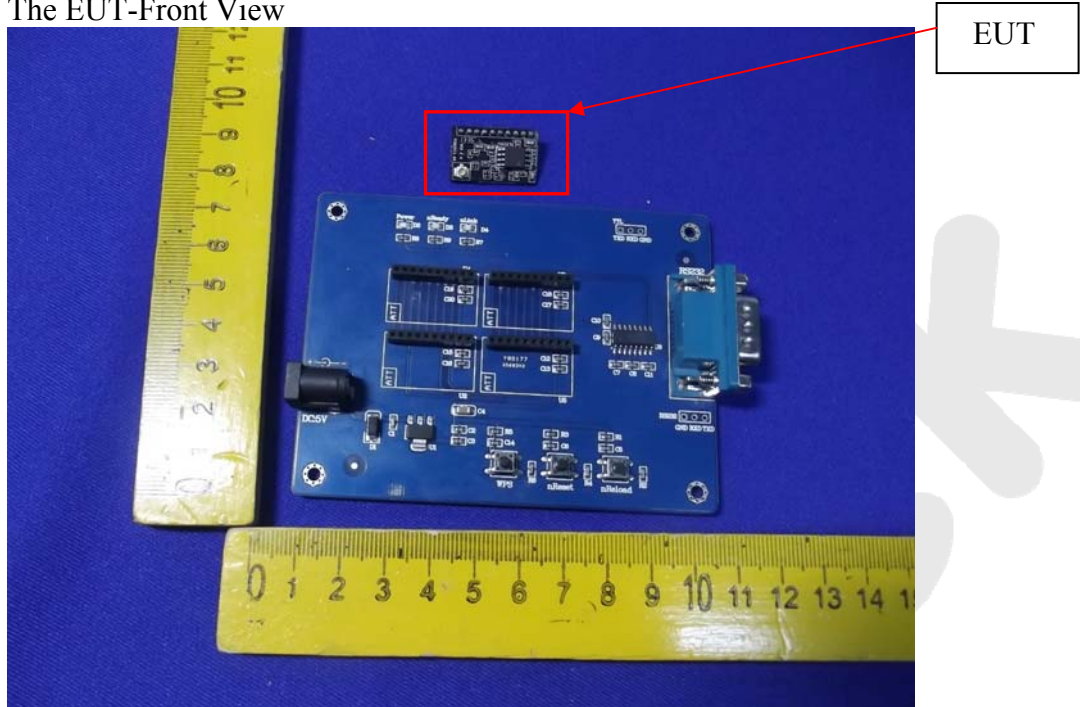
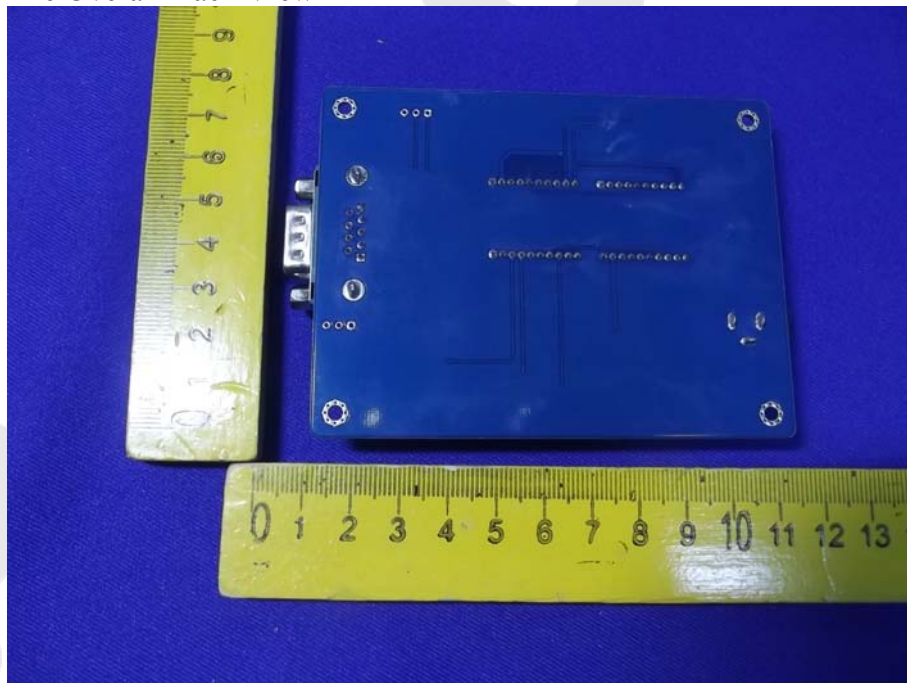

Figure 4
The Overall-Back View



Appendix II (Internal Photos)

Figure 5
PCB of the EUT-Front View

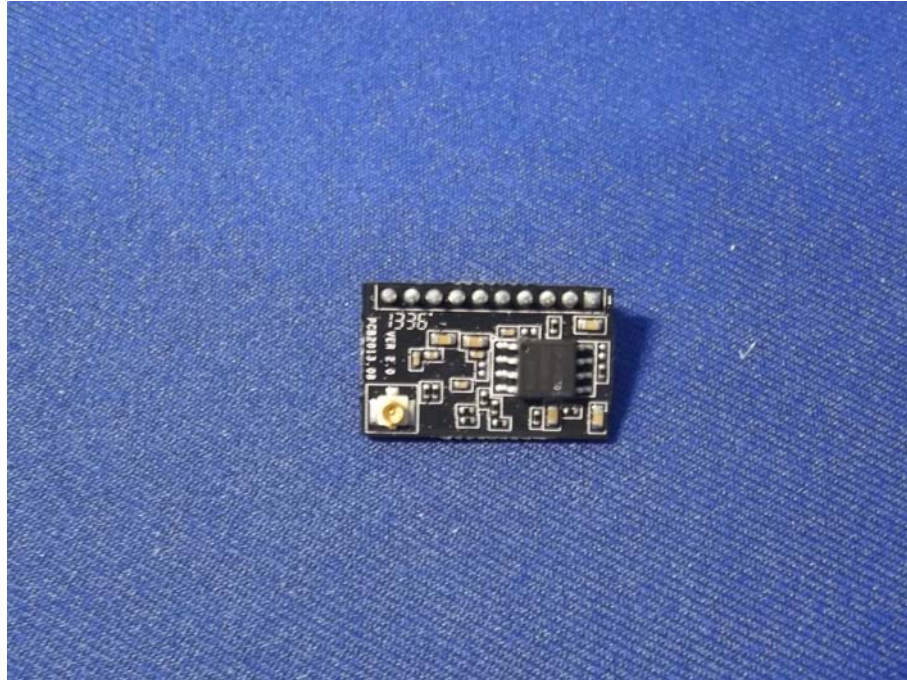

Figure 6
PCB of the EUT-Back View

