

FCC TEST REPORT
for
High-Flying Electronics Technology Co., Ltd
Embedded Wi-Fi Module
Model No.: HF-LPB100

Prepared for : High-Flying Electronics Technology Co., Ltd
Address : Room 511, #7Building, No.365 Chuanhong Road, Pudong,
Shanghai, China

Prepared By : Shenzhen Anbotek Compliance Laboratory Limited
Address : 1/F., Building 1, SEC Industrial Park, No.0409 Qianhai Road,
Nanshan District, Shenzhen, Guangdong, China
Tel: (86) 755-26066544
Fax: (86) 755-26014772

Report Number : 201311816F
Date of Test : Nov. 18~ Dec. 04, 2013
Date of Report : Dec. 05, 2013

TABLE OF CONTENT

Description

Page

Test Report

1. GENERAL INFORMATION	4
1.1. Description of Device (EUT).....	4
1.2. Auxiliary Equipment Used during Test.....	5
1.3. Description of Test Facility	5
1.4. Measurement Uncertainty.....	5
2. TEST METHODOLOGY	6
2.1. Summary of Test Results.....	6
2.2. Description of Test Modes.....	6
2.3. List of channels:.....	7
3. CONDUCTED EMISSION TEST.....	8
3.1. Block Diagram of Test Setup	8
3.2. Power Line Conducted Emission Measurement Limits (15.207).....	8
3.3. Configuration of EUT on Measurement	8
3.4. Operating Condition of EUT	8
3.5. Test Procedure	9
3.6. Test equipment	9
3.7. Power Line Conducted Emission Measurement Results	9
4. FCC PART 15.247 REQUIREMENTS FOR DSSS & OFDM MODULATION.....	12
4.1 Test Setup	12
4.2 6dB Bandwidth	12
4.3. Maximum Peak output power test	20
4.4. Band Edges Measurement	28
4.5. Peak Power Spectral Density	41
4.6. Radiated Emissions.....	49
5. PHOTOGRAPH.....	60
5.1. Photo of Conducted Emission Measurement.....	60
5.2. Photo of Radiation Emission Test	60

Appendix I (2 Pages)

Appendix II (1 Page)

TEST REPORT

Applicant : High-Flying Electronics Technology Co., Ltd
Manufacturer : High-Flying Electronics Technology Co., Ltd
EUT : Embedded Wi-Fi Module
Model No. : HF-LPB100
Serial No. : N/A
Trade Mark : High-Flying
Rating : DC 3.1V-3.6V, 240mA

Measurement Procedure Used:
FCC Part15 Subpart C, Paragraph 15.247

The device described above is tested by Shenzhen Anbotek Compliance Laboratory Limited to determine the maximum emission levels emanating from the device and the severe levels of the device can endure and its performance criterion. The measurement results are contained in this test report and Shenzhen Anbotek Compliance Laboratory Limited is assumed full of responsibility for the accuracy and completeness of these measurements. Also, this report shows that the EUT (Equipment Under Test) is technically compliant with the FCC Part 15 Subpart C requirements.

This report applies to above tested sample only and shall not be reproduced in part without written approval of Shenzhen Anbotek Compliance Laboratory Limited.

Date of Test : Nov. 18~ Dec. 04, 2013

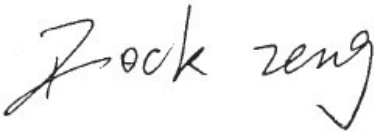
Prepared by : 
(Tested Engineer / Rock Zeng)

Reviewer : 
(Project Manager / Sally Zhang)

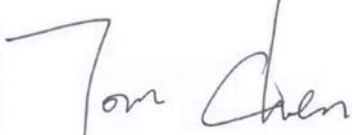
Approved & Authorized Signer : 
(Manager / Tom Chen)

1. GENERAL INFORMATION

1.1. Description of Device (EUT)

EUT : Embedded Wi-Fi Module

Model Number : HF-LPB100

Test Power Supply : AC 120V/60Hz for adapter

RF Transmission Frequency : 2412MHz~2462MHz (802.11b/802.11g/802.11n(HT20))
2422MHz~2452MHz (802.11n(HT40))

Channels : 11 For (802.11b/802.11g/802.11n(HT20))
7 For (802.11n(HT40))

Modulation : 802.11b CCK
802.11g OFDM
802.11n MCS

Antenna Specification : Type: Internal Antenna
Model: HF-LPB0614
Brand: High-Flying
Gain: 2.0dBi

Applicant : High-Flying Electronics Technology Co., Ltd

Address : Room 511, #7Building, No.365 Chuanhong Road, Pudong,
Shanghai, China

Manufacturer : High-Flying Electronics Technology Co., Ltd

Address : Room 511, #7Building, No.365 Chuanhong Road, Pudong,
Shanghai, China

Factory : Shanghai Quick Turn Electronic Co., Ltd.

Address : 4F, Bldg. 1, No. 1069 Chuansha Road, Pudong New District,
Shanghai, China

Date of receiver : Nov. 18, 2013

Date of Test : Nov. 18~ Dec. 04, 2013

1.2. Auxiliary Equipment Used during Test

N/A

1.3. Description of Test Facility

The test facility is recognized, certified, or accredited by the following organizations:

CNAS - LAB Code: L3503

Shenzhen Anbotek Compliance Laboratory Limited., Laboratory has been assessed and in compliance with CNAS/CL01: 2006 accreditation criteria for testing laboratories (identical to ISO/IEC 17025:2005 General Requirements) for the Competence of Testing Laboratories.

FCC-Registration No.: 752021

Shenzhen Anbotek Compliance Laboratory Limited, EMC Laboratory has been registered and fully described in a report filed with the (FCC) Federal Communications Commission. The acceptance letter from the FCC is maintained in our files. Registration 752021, July 10, 2013.

IC-Registration No.: 8058A-1

Shenzhen Anbotek Compliance Laboratory Limited., EMC Laboratory has been registered and fully described in a report filed with the (IC) Industry Canada. The acceptance letter from the IC is maintained in our files. Registration 8058A, February 22, 2013.

Test Location

All Emissions tests were performed at
Shenzhen Anbotek Compliance Laboratory Limited. at 1/F., Building 1, SEC Industrial Park, No.0409 Qianhai Road, Nanshan District, Shenzhen, Guangdong, China

1.4. Measurement Uncertainty

Radiation Uncertainty : Ur = 4.3dB

Conduction Uncertainty : Uc = 3.4dB

2. TEST METHODOLOGY

The tests documented in this report were performed in accordance with ANSI C63.4: 2009 and FCC Part 15, Paragraph 15.247.

2.1. Summary of Test Results

The EUT has been tested according to the following specifications:

Standard	Test Type	Result	Notes
FCC Part 15, Paragraph 15.107, 15.207	Conducted Emission Test	PASS	Complies
FCC Part 15, Paragraph 15.247(b)(1)	Peak Output Power	PASS	Complies
FCC Part 15, Paragraph 15.247(a)(2)	6dB Bandwidth	PASS	Complies
FCC Part 15, Paragraph 15.247(c)	100kHz Bandwidth of Frequency Band Edges	PASS	Complies
FCC Part 15, Paragraph 15.209(a)(f)	Spurious Emission	PASS	Complies
FCC Part 15, Paragraph 15.247(a)(1)	Frequency Separation	-	N/A
FCC Part 15, Paragraph 15.247(a)(1)(iii)	Number of Hopping Frequency	-	N/A
FCC Part 15, Paragraph 15.247(a)(1)(iii)	Time of Occupancy	-	N/A
FCC Part 15, Paragraph 15.247(c)	Peak Power Density	PASS	Complies

2.2. Description of Test Modes

The EUT has been tested under operating condition.

Software used to control the EUT for staying in continuous transmitting and receiving mode is programmed.

IEEE802.11b: Channel 1(2412MHz), Channel 6(2437MHz) and Channel 11(2462MHz) with 1 Mbps lowest data rate (worst case) are chosen for the final testing.

IEEE802.11g: Channel 1(2412MHz), Channel 6(2437MHz) and Channel 11(2462MHz) with 6 Mbps lowest data rate (the worst case) are chosen for the final testing.

IEEE802.11n (HT20): Channel 1(2412MHz), Channel 6(2437MHz) and Channel 11(2462MHz) with MCS 0 Mbps lowest data rate (the worst case) are chosen for the final testing.

IEEE802.11n (HT40): Channel 3(2422MHz), Channel 6(2437MHz) and Channel 9(2452MHz) with MCS 0 Mbps lowest data rate (the worst case) are chosen for the final testing.

2.3. List of channels:

√ - available

X - tested

Number	Frequency(MHz)		802.11 b/g/n (HT20)	802.11 b/g/n (HT40)
1	2412	√	X	
2	2417	√		
3	2422	√		X
4	2427	√		
5	2432	√		
6	2437	√	X	X
7	2442	√		
8	2447	√		
9	2452	√		X
10	2457	√		
11	2462	√	X	

3. Conducted Emission Test

3.1. Block Diagram of Test Setup

3.1.1. Block diagram of connection between the EUT and simulators

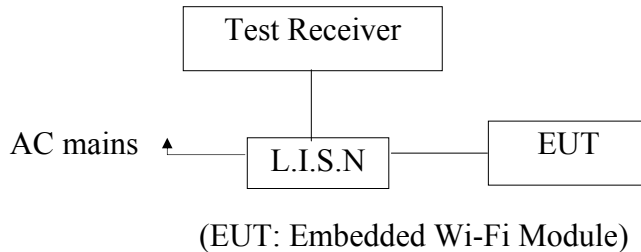

3.2. Power Line Conducted Emission Measurement Limits (15.207)

Frequency MHz	Limits dB(μV)	
	Quasi-peak Level	Average Level
0.15 ~ 0.50	66 ~ 56*	56 ~ 46*
0.50 ~ 5.00	56	46
5.00 ~ 30.00	60	50

- Notes: 1. *Decreasing linearly with logarithm of frequency.
2. The lower limit shall apply at the transition frequencies.

3.3. Configuration of EUT on Measurement

The following equipments are installed on Power Line Conducted Emission Measurement to meet the commission requirement and operating regulations in a manner which tends to maximize its emission characteristics in a normal application.

- EUT : Embedded Wi-Fi Module
Model Number : HF-LPB100
Applicant : High-Flying Electronics Technology Co., Ltd

3.4. Operating Condition of EUT

- 3.4.1. Setup the EUT and simulator as shown as Section 3.1.
3.4.2. Turn on the power of all equipment.
3.4.3. Let the EUT work in test mode (On) and measure it.

3.5. Test Procedure

The EUT system is connected to the power mains through a line impedance stabilization network (L.I.S.N.). This provides a 50ohm coupling impedance for the EUT system. Please refer the block diagram of the test setup and photographs. Both sides of AC line are checked to find out the maximum conducted emission. In order to find the maximum emission levels, the relative positions of equipment and all of the interface cables shall be changed according to FCC ANSI C63.4-2003 on Conducted Emission Measurement.

The bandwidth of test receiver (ESCI) set at 9KHz.

The frequency range from 150KHz to 30MHz is checked.

The test results are reported on Section 3.6.

3.6. Test equipment

Item	Equipment	Manufacturer	Model No.	Serial No.	Last Cal.	Cal. Interval
1.	Two-Line V-network	Rohde & Schwarz	ENV216	100055	Apr. 23, 2013	1 Year
2.	EMI Test Receiver	Rohde & Schwarz	ESCI	100627	Apr. 23, 2013	1 Year
3.	RF Switching Unit	Compliance Direction	RSU-M2	38303	Apr. 23, 2013	1 Year

3.7. Power Line Conducted Emission Measurement Results

PASS.

The frequency range from 150KHz to 30 MHz is investigated.

Please refer the following pages.

CONDUCTED EMISSION TEST DATA

EUT: Embedded Wi-Fi Module M/N:HF-LPB100
 Operating Condition: On
 Test Site: 1# Shielded Room
 Operator: Bevan Zhang
 Test Specification: AC 120V/60Hz for adapter
 Comment: L
 Tem:25°C Hum:50%

SCAN TABLE: "Voltage (150K~30M) FIN"

Short Description: 150K-30M Disturbance Voltages

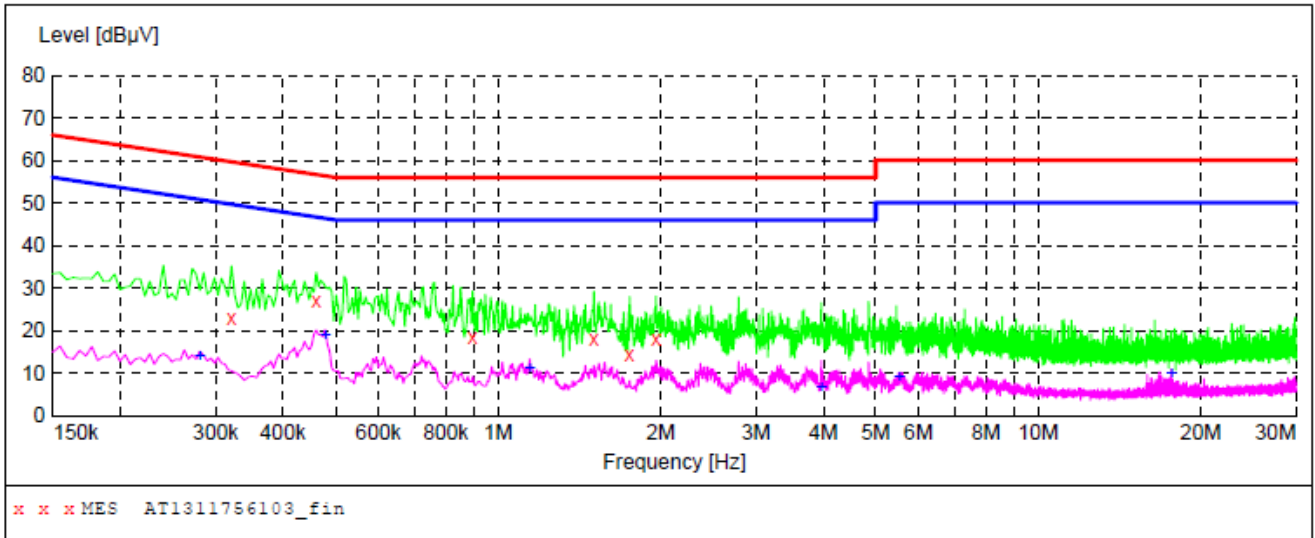

MEASUREMENT RESULT: "AT1311756103_fin"

11/18/2013 5:15PM

Frequency MHz	Level dBµV	Transd dB	Limit dBµV	Margin dB	Detector	Line	PE
0.321000	22.90	20.1	60	36.8	QP	L1	GND
0.460500	27.10	20.1	57	29.6	QP	L1	GND
0.897000	18.50	20.1	56	37.5	QP	L1	GND
1.504000	17.90	20.3	56	38.1	QP	L1	GND
1.751500	14.30	20.3	56	41.7	QP	L1	GND
1.958500	18.00	20.3	56	38.0	QP	L1	GND

MEASUREMENT RESULT: "AT1311756103_fin2"

11/18/2013 5:15PM

Frequency MHz	Level dBµV	Transd dB	Limit dBµV	Margin dB	Detector	Line	PE
0.280500	13.80	20.1	51	37.0	AV	L1	GND
0.478500	18.80	20.1	46	27.6	AV	L1	GND
1.144000	11.10	20.2	46	34.9	AV	L1	GND
3.965500	6.60	20.4	46	39.4	AV	L1	GND
5.527000	8.90	20.5	50	41.1	AV	L1	GND
17.650000	9.70	20.8	50	40.3	AV	L1	GND

CONDUCTED EMISSION TEST DATA

EUT: Embedded Wi-Fi Module M/N:HF-LPB100
 Operating Condition: On
 Test Site: 1# Shielded Room
 Operator: Bevan Zhang
 Test Specification: AC 120V/60Hz for adapter
 Comment: N
 Tem:25°C Hum:50%

SCAN TABLE: "Voltage (150K~30M) FIN"
 Short Description: 150K-30M Disturbance Voltages

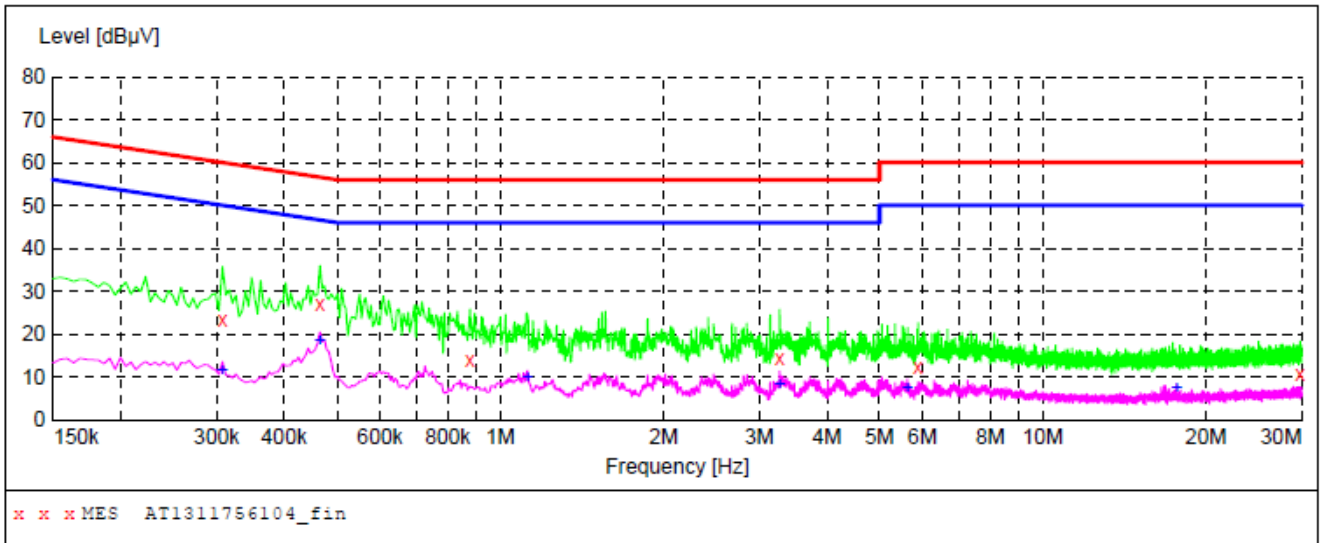

MEASUREMENT RESULT: "AT1311756104_fin"

11/18/2013 5:20PM

Frequency MHz	Level dBµV	Transd dB	Limit dBµV	Margin dB	Detector	Line	PE
0.307500	23.40	20.1	60	36.6	QP	N	GND
0.465000	27.20	20.1	57	29.4	QP	N	GND
0.879000	14.00	20.1	56	42.0	QP	N	GND
3.272500	14.40	20.4	56	41.6	QP	N	GND
5.887000	12.40	20.5	60	47.6	QP	N	GND
29.768500	10.80	20.9	60	49.2	QP	N	GND

MEASUREMENT RESULT: "AT1311756104_fin2"

11/18/2013 5:20PM

Frequency MHz	Level dBµV	Transd dB	Limit dBµV	Margin dB	Detector	Line	PE
0.307500	11.30	20.1	50	38.7	AV	N	GND
0.465000	18.60	20.1	47	28.0	AV	N	GND
1.121500	9.90	20.2	46	36.1	AV	N	GND
3.272500	8.30	20.4	46	37.7	AV	N	GND
5.626000	7.40	20.5	50	42.6	AV	N	GND
17.650000	7.30	20.8	50	42.7	AV	N	GND

4. FCC Part 15.247 Requirements for DSSS & OFDM Modulation

4.1 Test Setup

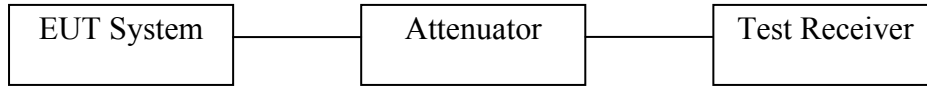

4.2 6dB Bandwidth

a. Limit

For the direct sequence systems, the minimum 6dB bandwidth shall be at least 500kHz.

b. Test Procedure

1. Place the EUT on the table and set it in the transmitting mode.
2. Remove the antenna from the EUT and then connect a low loss RF cable from the antenna port to the spectrum analyzer.
3. Set the spectrum analyzer as:
 RBW = 100kHz, VBW \geq 3*RBW = 300kHz,
 Detector= Peak
 Trace mode= Max hold.
 Sweep- auto couple.
4. Mark the peak frequency and -6dB (upper and lower) frequency.
5. Repeat until all the rest channels are investigated.

c. Test Setup See 4.1

d. Test Equipment

Item	Equipment	Manufacturer	Model No.	Serial No.	Last Cal.	Cal. Interval
1.	Spectrum Analysis	Agilent	E4407B	US39390582	Aug. 09, 2013	1 Year
2.	Preamplifier	Instruments corporation	EMC011830	980100	Aug. 09, 2013	1 Year
3.	EMI Test Receiver	Rohde & Schwarz	ESPI	101604	Apr. 23, 2013	1 Year
4.	Double Ridged Horn Antenna	Instruments corporation	GTH-0118	351600	Aug. 09, 2013	3 Year
5.	EMI Test Software EZ-EMC	SHURPLE	N/A	N/A	N/A	N/A

e. Test Results

Pass.

f. Test Data

Test mode: IEEE 802.11b

Channel	Frequency (MHz)	Bandwidth (MHz)	Limit (kHz)	Results
Low	2412	11.94		Pass
Mid	2437	12.04	>500	Pass
High	2462	11.94		Pass

Test mode: IEEE 802.11g

Channel	Frequency (MHz)	Bandwidth (MHz)	Limit (kHz)	Results
Low	2412	16.24		Pass
Mid	2437	16.37	>500	Pass
High	2462	16.24		Pass

Test mode: IEEE 802.11n (HT20)

Channel	Frequency (MHz)	Bandwidth (MHz)	Limit (kHz)	Results
Low	2412	17.05		Pass
Mid	2437	16.99	>500	Pass
High	2462	16.94		Pass

Test mode: IEEE 802.11n (HT40)

Channel	Frequency (MHz)	Bandwidth (MHz)	Limit (kHz)	Results
Low	2422	35.36		Pass
Mid	2437	35.36	>500	Pass
High	2452	35.36		Pass

Test Plots See the following page.

Test Mode: 802.11b---Low

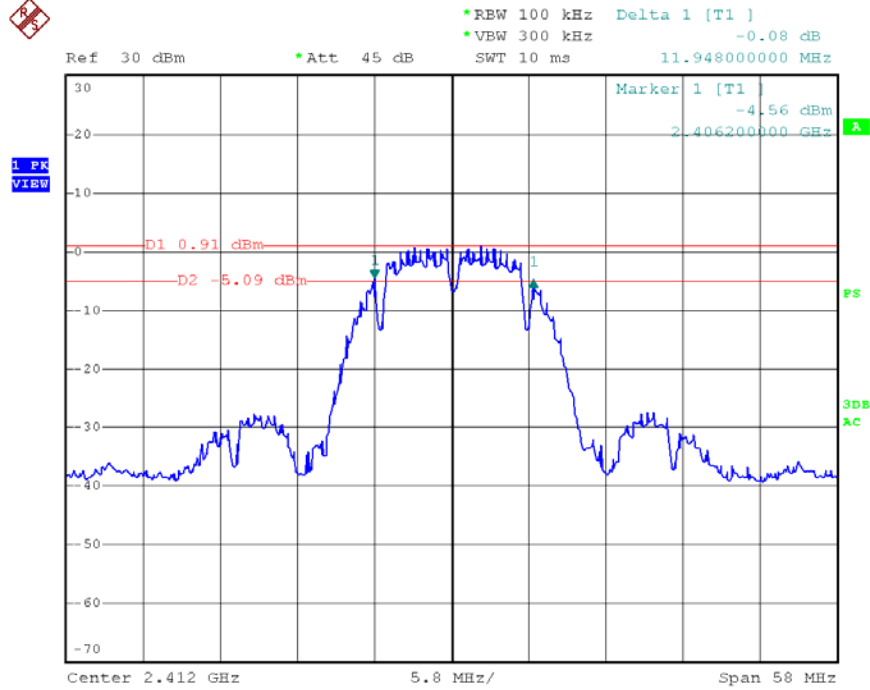

Date: 23.NOV.2013 10:11:56

Test Mode: 802.11b---Mid

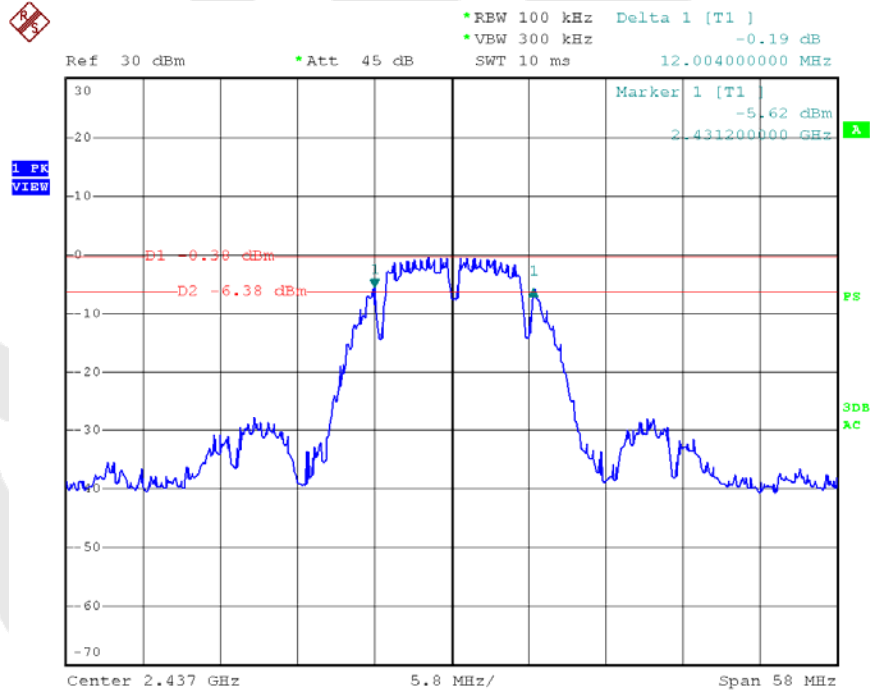

Date: 23.NOV.2013 10:13:24

Test Mode: 802.11b---High

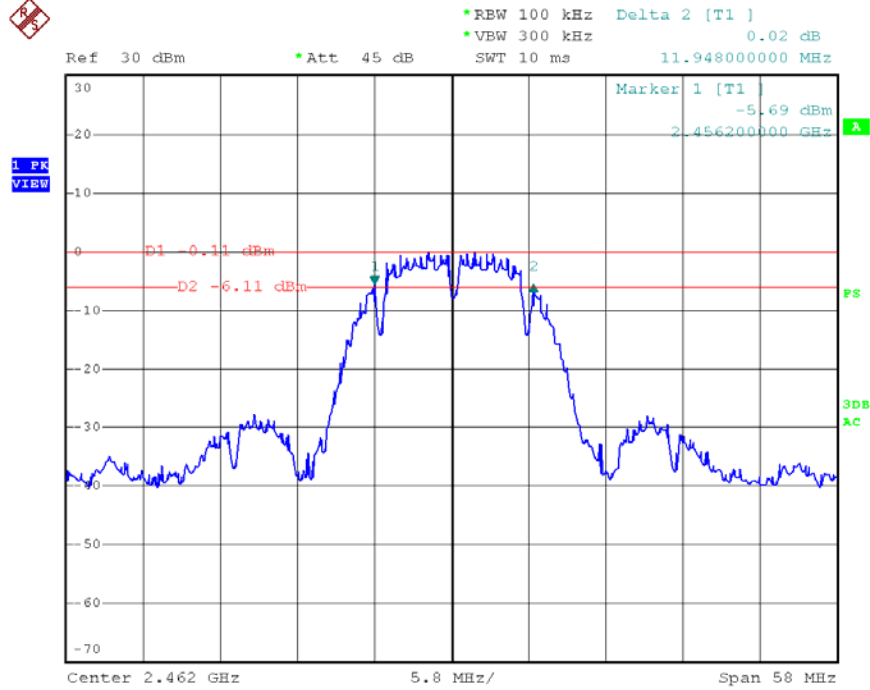

Date: 23.NOV.2013 10:14:46

Test Mode: 802.11g---Low

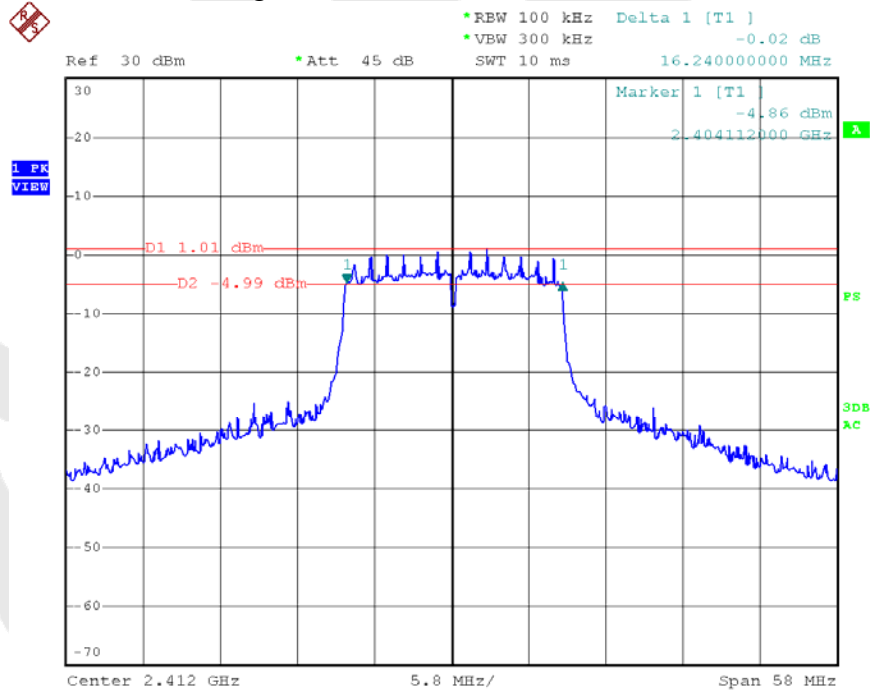

Date: 23.NOV.2013 10:16:03

Test Mode: 802.11g---Mid

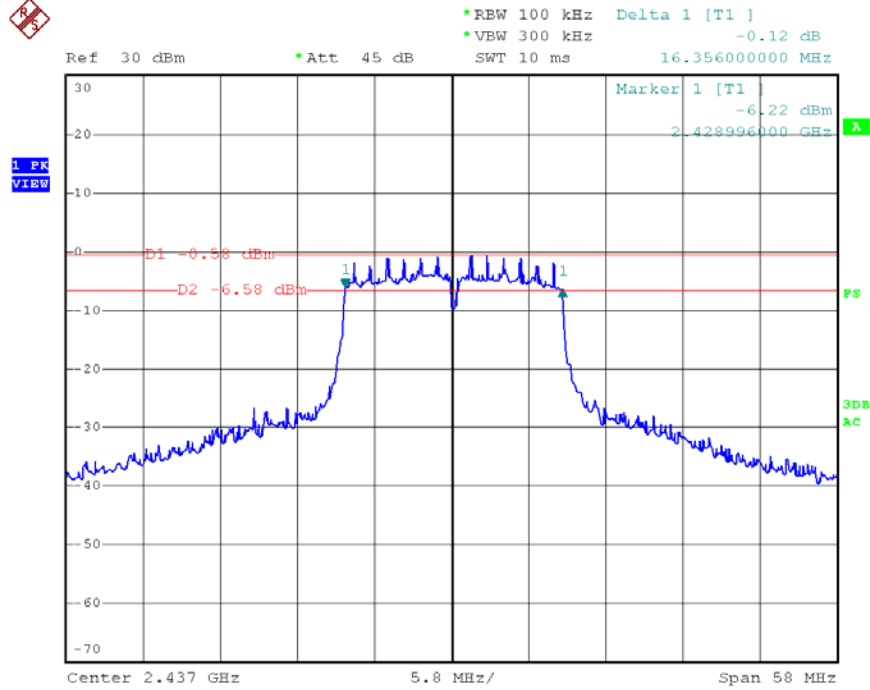

Date: 23.NOV.2013 10:18:03

Test Mode: 802.11g---High

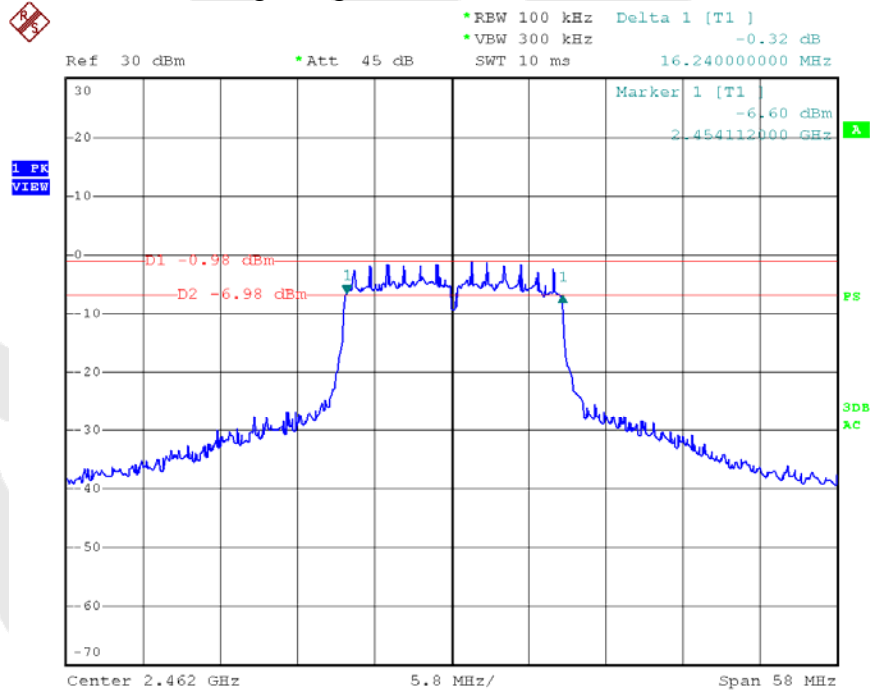

Date: 23.NOV.2013 10:19:25

Test Mode: 802.11n (HT20)---Low

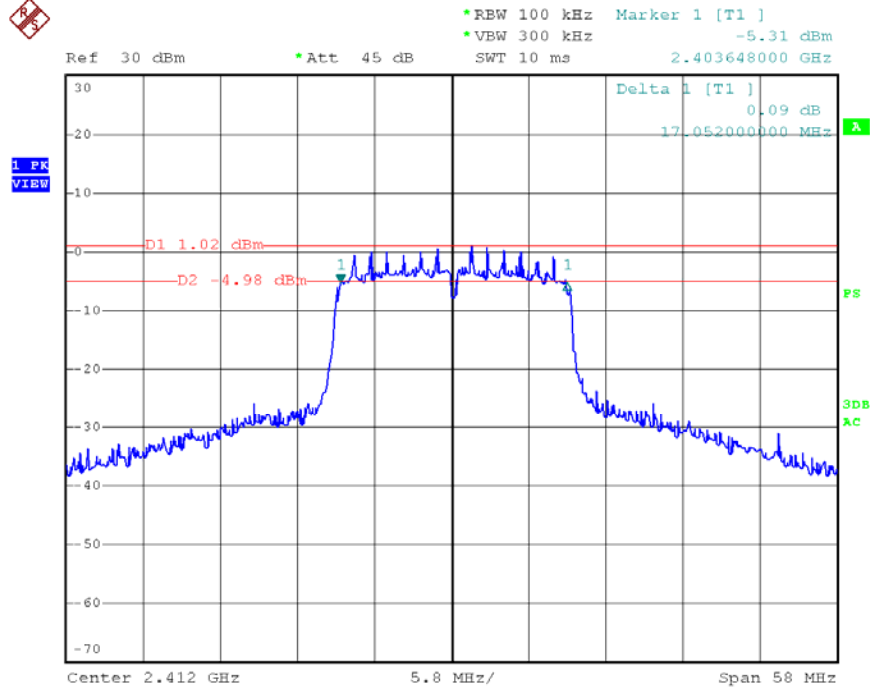

Date: 23.NOV.2013 10:20:52

Test Mode: 802.11n (HT20)---Mid

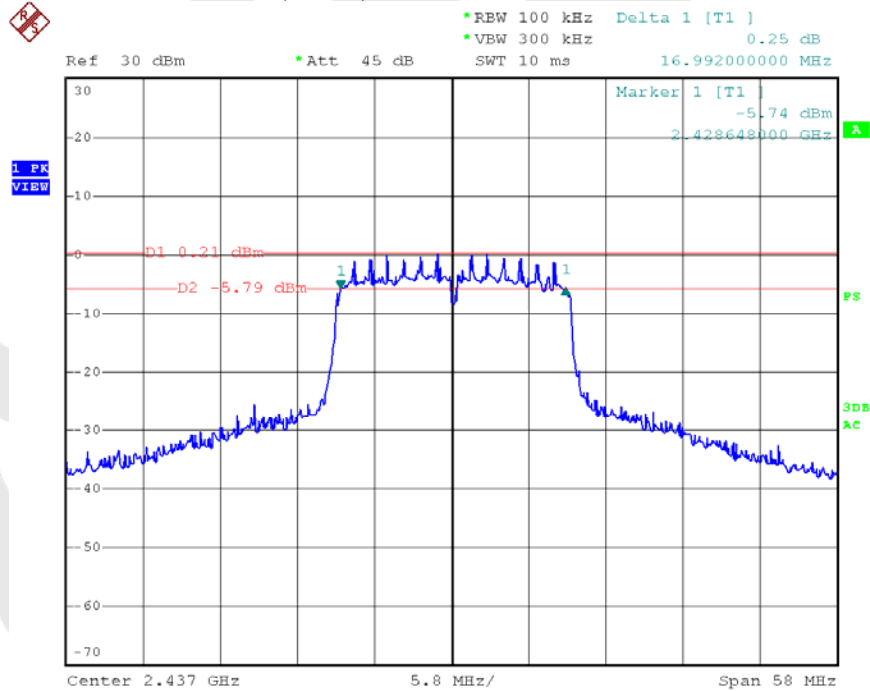

Date: 23.NOV.2013 10:22:42

Test Mode: 802.11n (HT20)---High

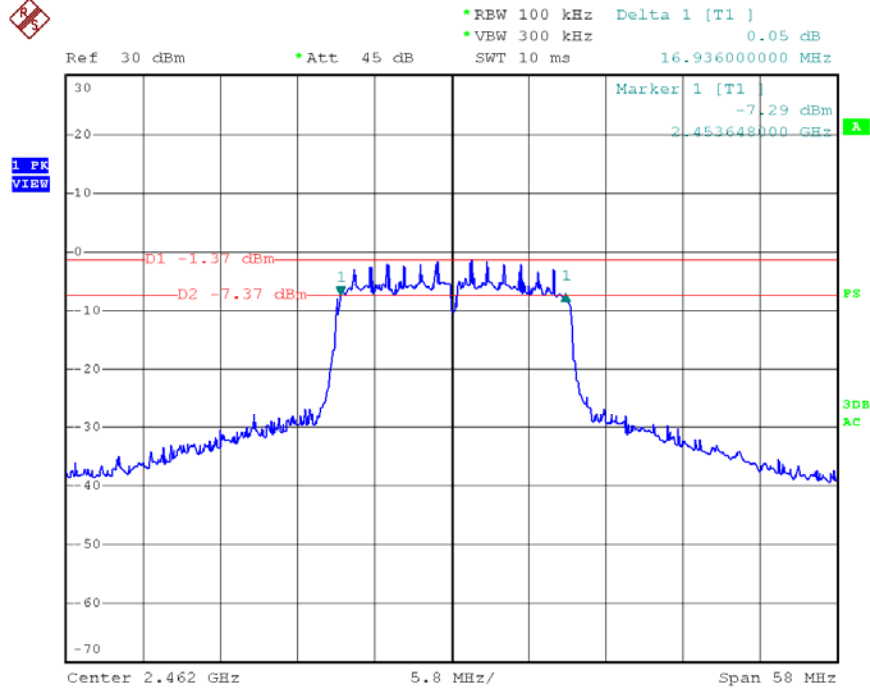

Date: 23.NOV.2013 10:23:51

Test Mode: 802.11n (HT40)---Low

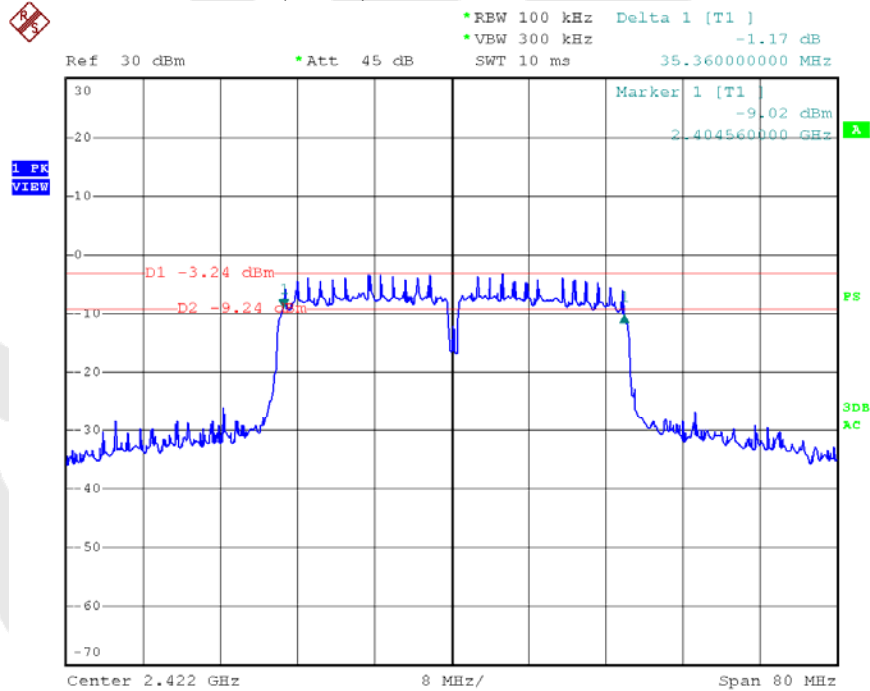

Date: 23.NOV.2013 10:25:32

Test Mode: 802.11n (HT40)---Mid

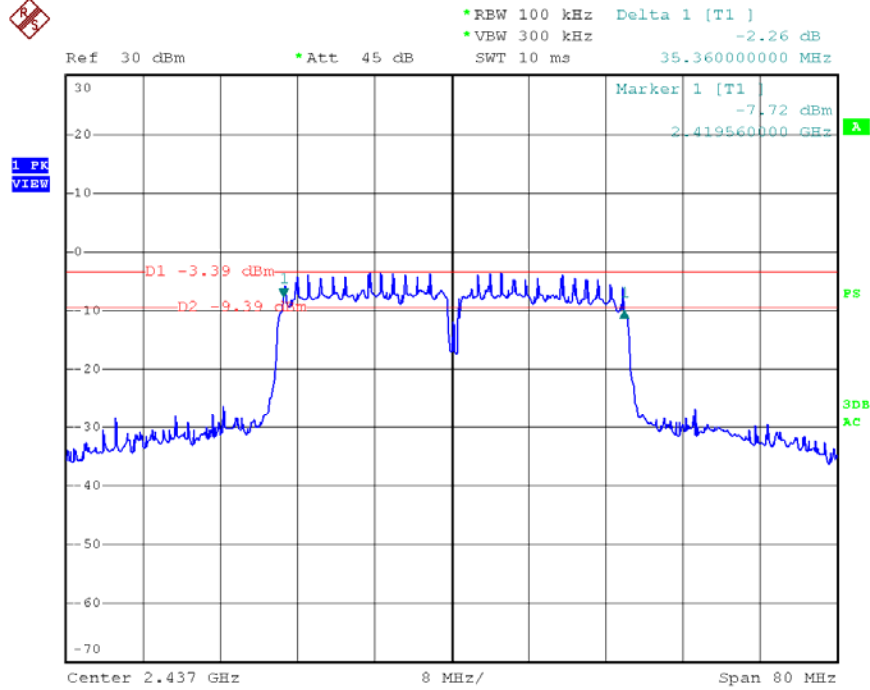

Date: 23.NOV.2013 10:26:58

Test Mode: 802.11n (HT40)---High

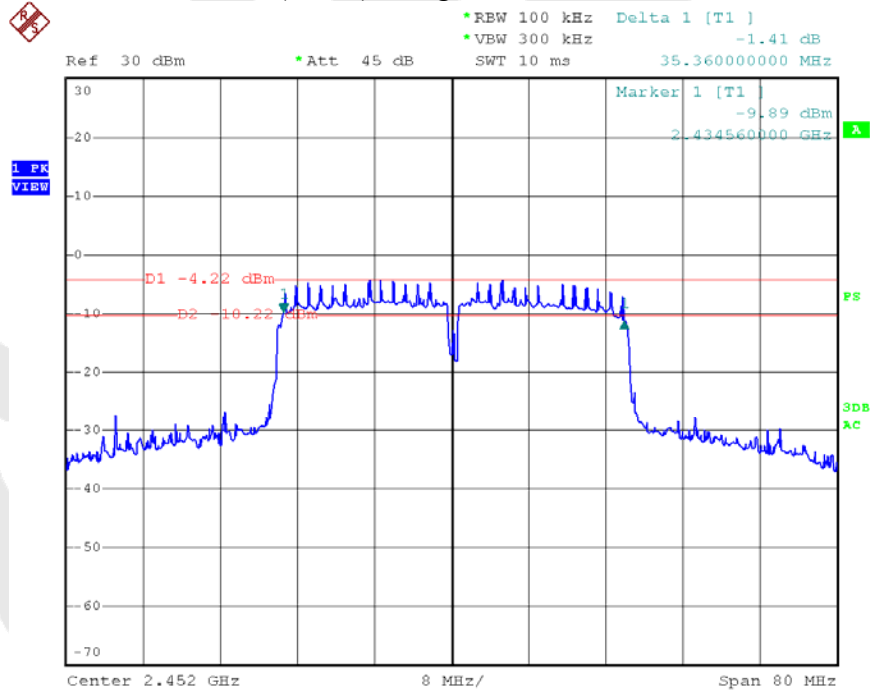

Date: 23.NOV.2013 10:28:33

4.3. Maximum Peak output power test

a. Limit

The maximum peak output power of the intentional radiator shall not exceed the following:

1. For systems using digital modulation in the bands of 902-928 MHz, 2400-2483.5 MHz, and 5725-5850 MHz: 1 watt (30dBm).
2. Except as shown in paragraphs (b)(3) (i), (ii) and (iii) of this section, if transmitting antenna of directional gain greater than 6 dBi are used the peak output power from the intentional radiator shall be reduced below the stated values in paragraphs (b)(1) or (b)(2) of this section, as appropriate, by the amount in dB that the directional gain of the antenna exceeds 6 dBi.

b. Configuration of Measurement

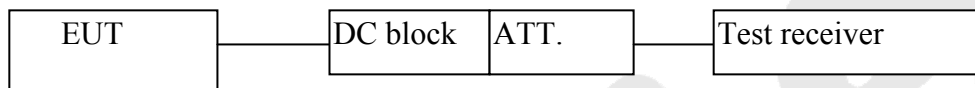

c. Data Rates

IEEE802.11b: Channel 1(2412MHz), Channel 6(2437MHz) and Channel 11(2462MHz) with 1 Mbps data rate (worst case) are chosen for the final testing.

IEEE802.11g: Channel 1(2412MHz), Channel 6(2437MHz) and Channel 11(2462MHz) with 6 Mbps data rate (the worst case) are chosen for the final testing.

IEEE802.11n (HT20: Channel 1(2412MHz), Channel 6(2437MHz) and Channel 11(2462MHz) with 6.5Mbps data rate (the worst case) are chosen for the final testing.

IEEE802.11n (HT40: Channel 3(2422MHz), Channel 6(2437MHz) and Channel 9(2452MHz) with 13.5Mbps data rate (the worst case) are chosen for the final testing.

d. Test Procedure

This test was according the kDB 558074 9.1.2:

1. This procedure may be used when the maximum available RBW of the measurement instrument is less than the DTS bandwidth.
2. Set the RBW = 1 MHz.
3. Set the VBW $\geq 3 \times \text{RBW} = 3 \text{ MHz}$.
4. Set the span $\geq 1.5 \times \text{DTS bandwidth}$.
5. Detector = peak.
6. Sweep time = auto couple.
7. Trace mode = max hold.
8. Allow trace to fully stabilize.
9. Use the instrument's band/channel power measurement function with the band limits set equal to the DTS bandwidth edges (for some instruments, this may require a manual override to select peak detector). If the instrument does not have a band power function, sum the spectrum levels (in linear power units) at intervals equal to the RBW extending across the DTS bandwidth.

e. Test Equipment

Same as the equipment listed in 4.2.

f. Test Results

Pass.

g. Test Data

Test mode: IEEE 802.11b

Channel	Frequency (MHz)	Maximum transmit power (dBm)	Limit		Result
			(dBm)	(watts)	
Low	2412	16.65	30	1	Pass
Mid	2437	16.26			Pass
High	2462	16.44			Pass

Test mode: IEEE 802.11g

Channel	Frequency (MHz)	Maximum transmit power (dBm)	Limit		Result
			(dBm)	(watts)	
Low	2412	21.94	30	1	Pass
Mid	2437	20.85			Pass
High	2462	19.52			Pass

Test mode: IEEE 802.11n (HT20)

Channel	Frequency (MHz)	Maximum transmit power (dBm)	Limit		Result
			(dBm)	(watts)	
Low	2412	21.49	30	1	Pass
Mid	2437	20.70			Pass
High	2462	19.90			Pass

Test mode: IEEE 802.11n (HT40)

Channel	Frequency (MHz)	Maximum transmit power (dBm)	Limit		Result
			(dBm)	(watts)	
Low	2422	21.03	30	1	Pass
Mid	2437	20.33			Pass
High	2452	20.44			Pass

Test Mode: 802.11b---Low



*RBW 1 MHz
*VBW 3 MHz
SWT 2.5 ms

Marker 1 [T1]
7.89 dBm
2.413200000 GHz

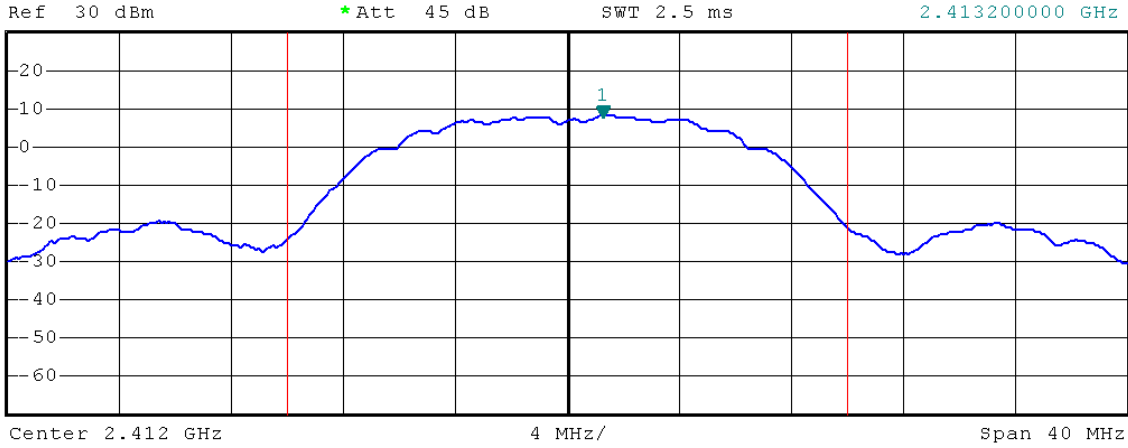

Tx Channel
Bandwidth 20 MHz Power 16.65 dBm

Test Mode: 802.11b---Mid



*RBW 1 MHz
*VBW 3 MHz
SWT 2.5 ms

Marker 1 [T1]
7.47 dBm
2.438280000 GHz

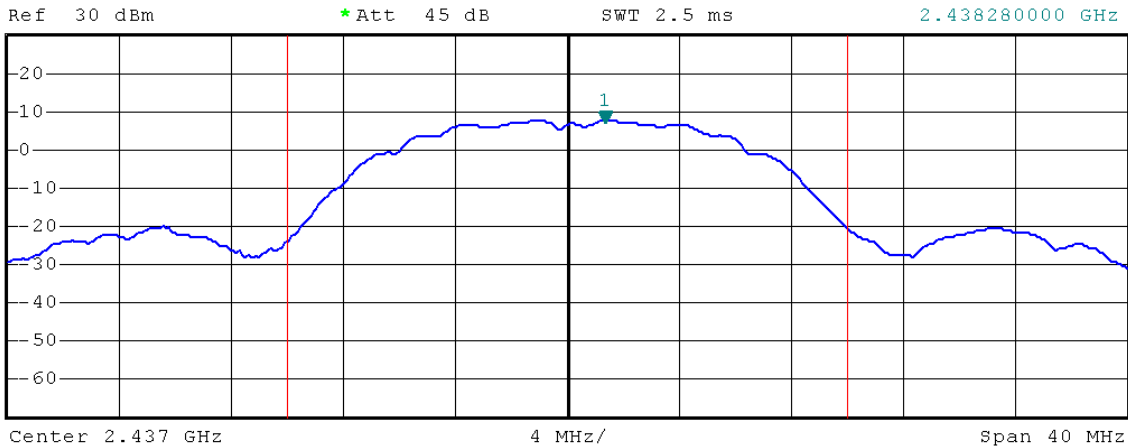

Tx Channel
Bandwidth 20 MHz Power 16.26 dBm

Test Mode: 802.11b---High



*RBW 1 MHz
*VBW 3 MHz
SWT 2.5 ms
Marker 1 [T1]
7.78 dBm
2.463680000 GHz

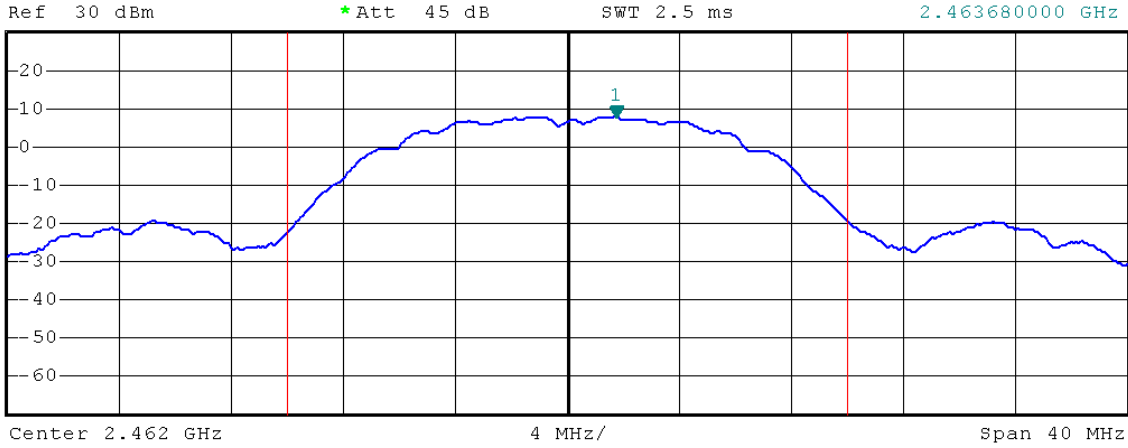

1 PK
MAXH

A
PS
3DB
AC

Tx Channel
Bandwidth 20 MHz Power 16.44 dBm

Test Mode: 802.11g---Low



*RBW 1 MHz
*VBW 3 MHz
SWT 2.5 ms
Marker 1 [T1]
12.10 dBm
2.407440000 GHz

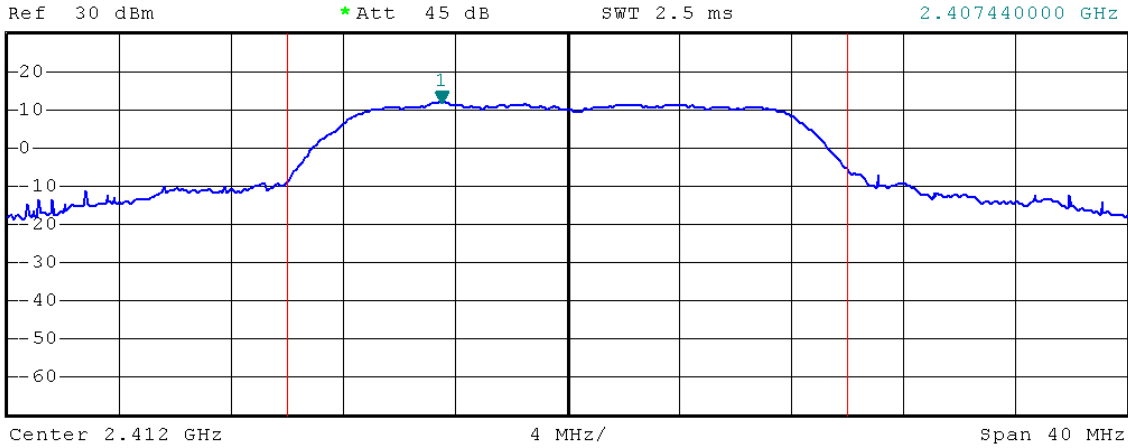

1 PK
MAXH

A
PS
3DB
AC

Tx Channel
Bandwidth 20 MHz Power 21.94 dBm

Test Mode: 802.11g---Mid



*RBW 1 MHz
*VBW 3 MHz
SWT 2.5 ms

Marker 1 [T1]
10.85 dBm
2.432360000 GHz

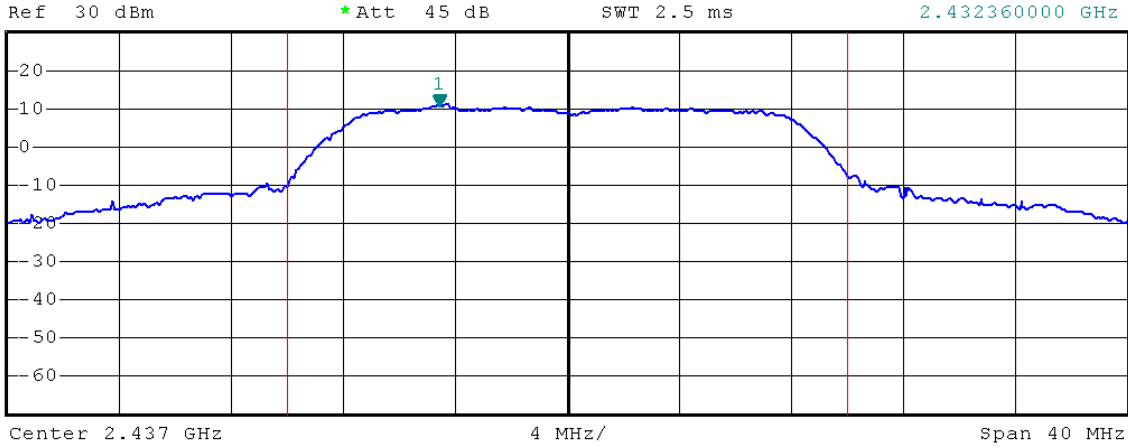

Tx Channel
Bandwidth 20 MHz Power 20.85 dBm

Test Mode: 802.11g---High



*RBW 1 MHz
*VBW 3 MHz
SWT 2.5 ms

Marker 1 [T1]
9.72 dBm
2.457520000 GHz

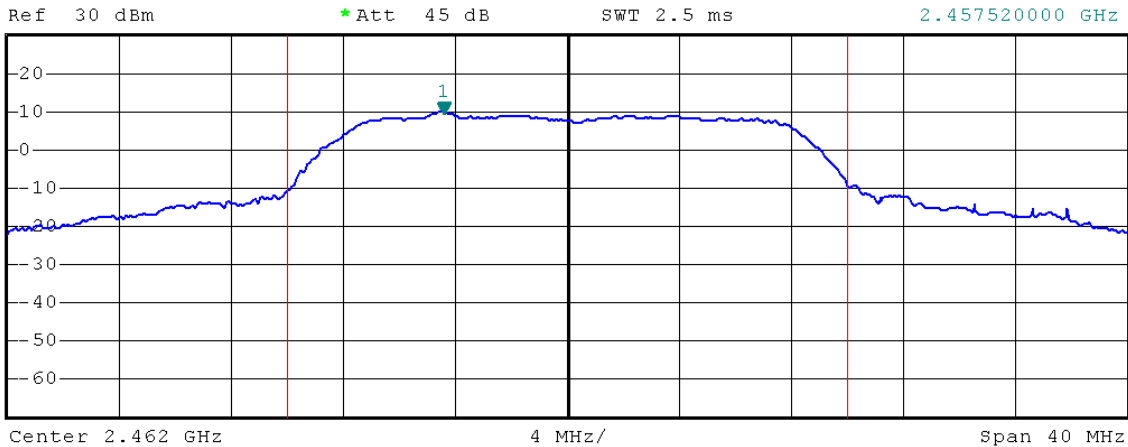

Tx Channel
Bandwidth 20 MHz Power 19.52 dBm

Test Mode: 802.11n(HT20)---Low



*RBW 1 MHz
*VBW 3 MHz
SWT 2.5 ms
Marker 1 [T1]
10.72 dBm
2.413680000 GHz

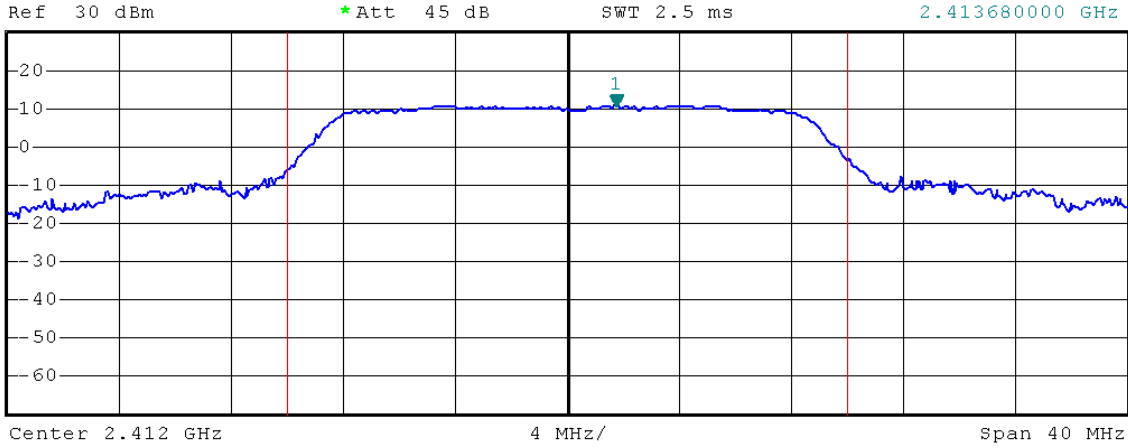

Tx Channel
Bandwidth 20 MHz Power 21.49 dBm

Test Mode: 802.11n(HT20)---Mid



*RBW 1 MHz
*VBW 3 MHz
SWT 2.5 ms
Marker 1 [T1]
9.86 dBm
2.434680000 GHz

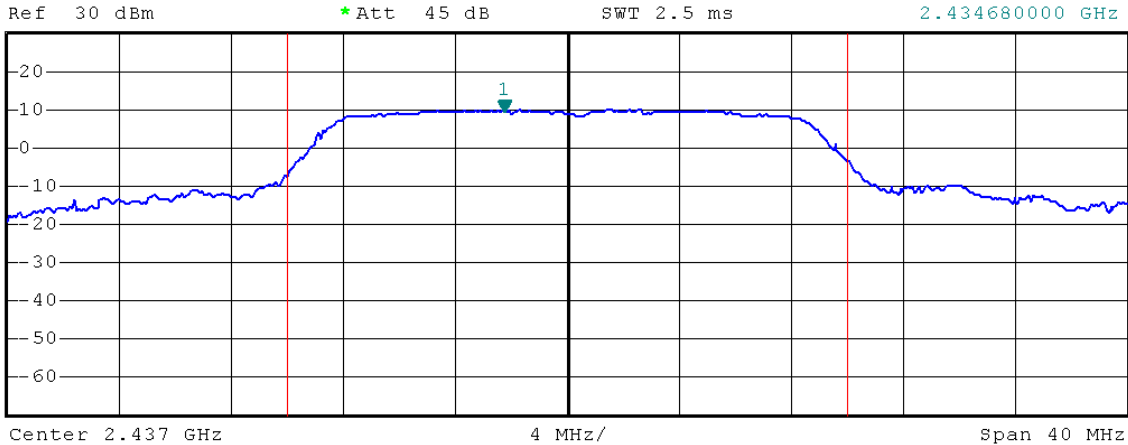

Tx Channel
Bandwidth 20 MHz Power 20.70 dBm

Test Mode: 802.11n(HT20)---High



*RBW 1 MHz
*VBW 3 MHz
SWT 2.5 ms
Marker 1 [T1]
9.18 dBm
2.460480000 GHz

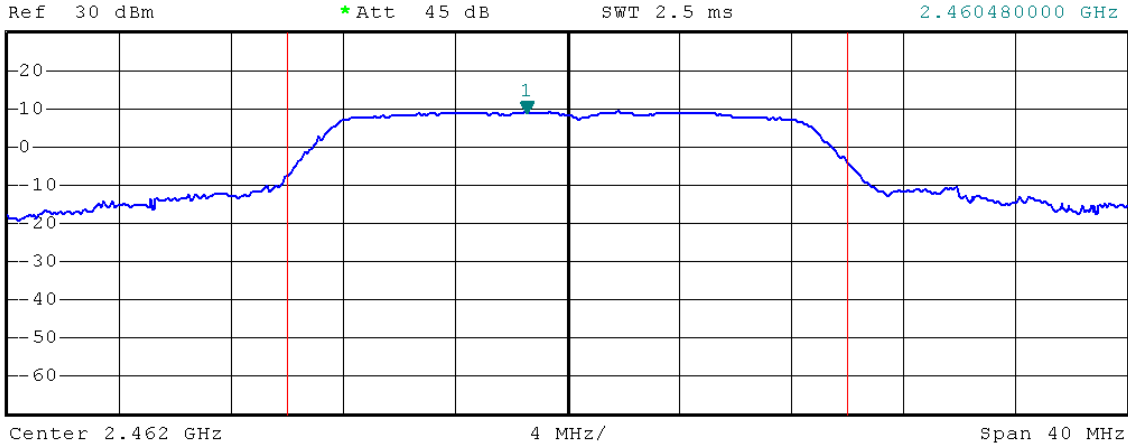

Tx Channel
Bandwidth 20 MHz Power 19.90 dBm

Test Mode: 802.11n(HT40)---Low



*RBW 1 MHz
*VBW 3 MHz
SWT 2.5 ms
Marker 1 [T1]
7.17 dBm
2.418320000 GHz

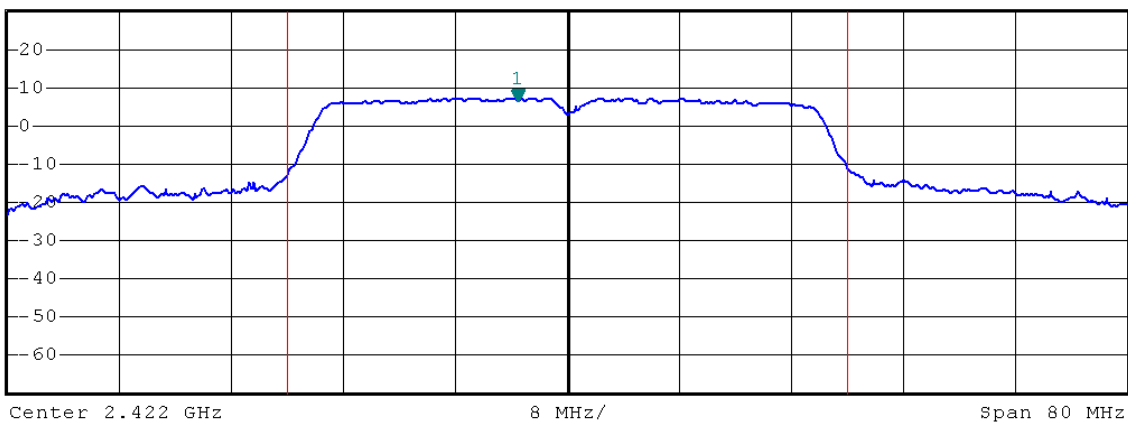

Tx Channel
Bandwidth 40 MHz Power 21.03 dBm

Test Mode: 802.11n(HT40)---Mid



*RBW 1 MHz
*VBW 3 MHz
SWT 2.5 ms

Marker 1 [T1]
6.68 dBm
2.433800000 GHz

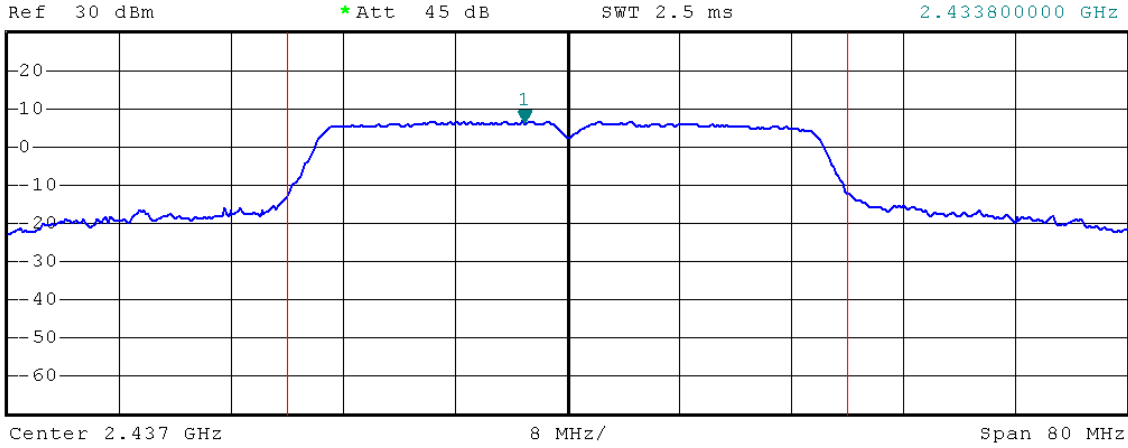

Tx Channel
Bandwidth 40 MHz Power 20.33 dBm

Test Mode: 802.11n(HT40)---High



*RBW 1 MHz
*VBW 3 MHz
SWT 2.5 ms

Marker 1 [T1]
6.99 dBm
2.436960000 GHz

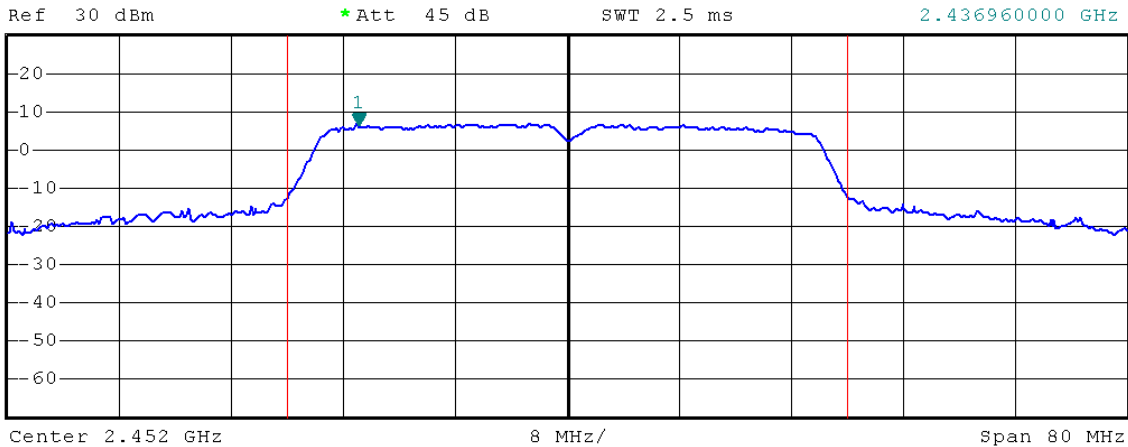

Tx Channel
Bandwidth 40 MHz Power 20.44 dBm

4.4. Band Edges Measurement

a. Limit

According to §15.247(c), in any 100 kHz bandwidth outside the frequency bands in which the spread spectrum intentional radiator is operating, the radio frequency power that is produced by the intentional radiator shall be at least 20dB below that in the 100kHz bandwidth within the band that contains the highest level of the desired power. In addition, radiated emissions which fall in the restricted bands, as defined in §15.205(a), must also comply with the radiated emission limits specified in §15.209(a).

b. Test Procedure

1. Conducted Method:

- 1) Set RBW=100KHz, VBW=300KHz
- 2) Detector=peak
- 3) Sweep time= auto
- 4) Trace mode=max hold.

2. Radiated Method:

- 1) The EUT is placed on a turntable, which is 0.8m above the ground plane.
- 2) The turntable shall be rotated for 360 degrees to determine the position of maximum emission level.
- 3) EUT is set 3m away from the receiving antenna, which is varied from 1m to 4m to find out the highest emission.
- 4) Peak detector: RBW=1MHz, VBW=3MHz, SWT=AUTO
Average detector: RBW=1MHz, VBW=10Hz, SWT=AUTO
The EUT is tested in 9*6*6 Chamber.
- 5) Repeat the procedures until all the PEAK and AVERAGE versus POLARIZATION are measured.

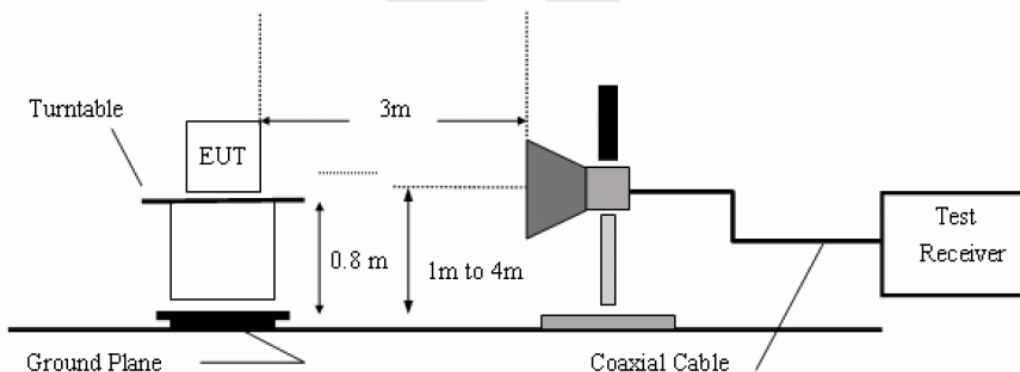

c. Test Equipment

Same as the equipment listed in 4.2.

d. Test Results

Pass.

e. Test Plots

See the following page.

Test Mode: 802.11b ---Low

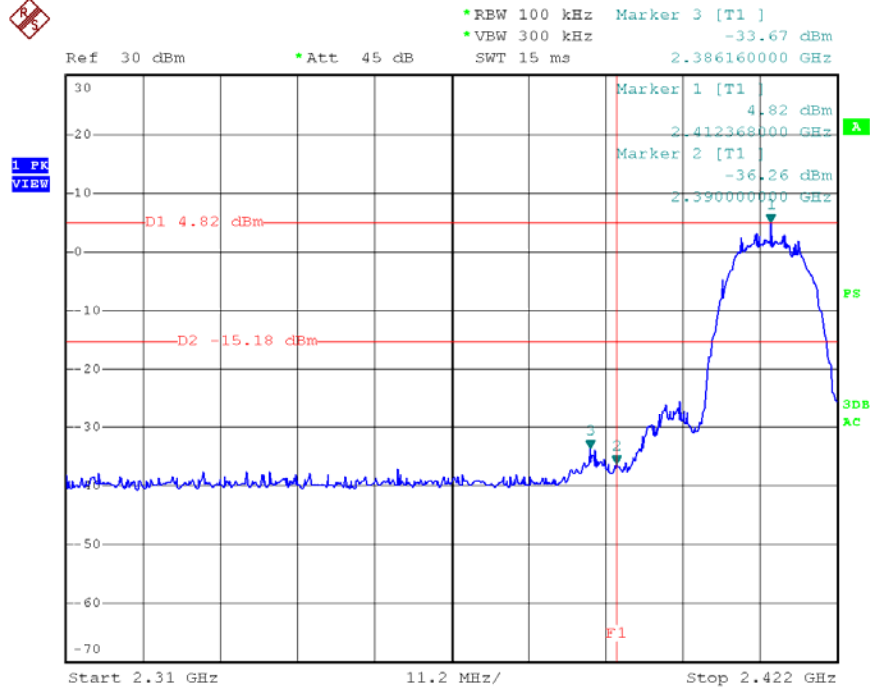

Date: 23.NOV.2013 09:28:05

Test Mode: 802.11b ---High

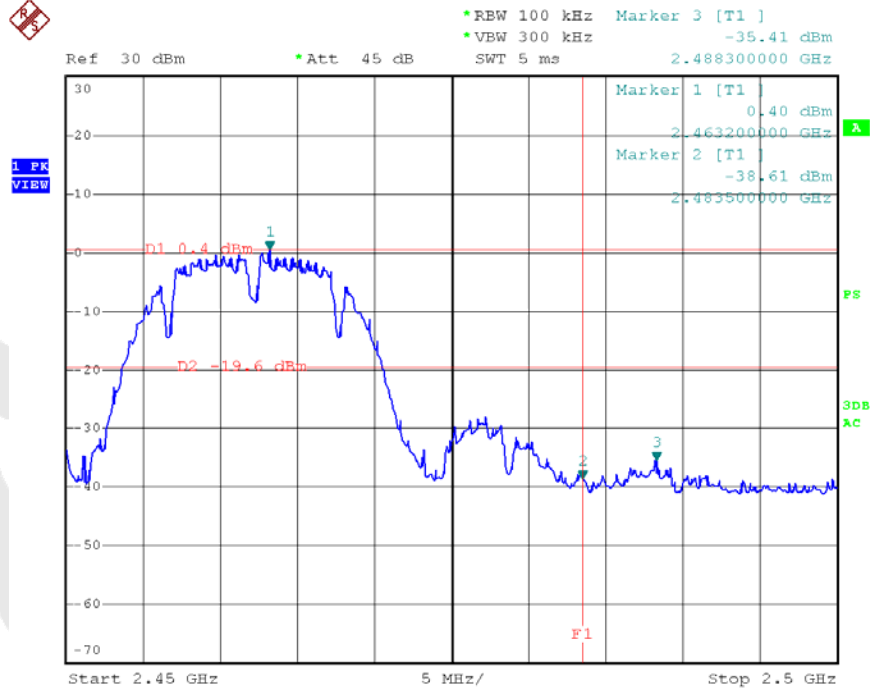

Date: 23.NOV.2013 10:03:10

Test Mode: 802.11g ---Low

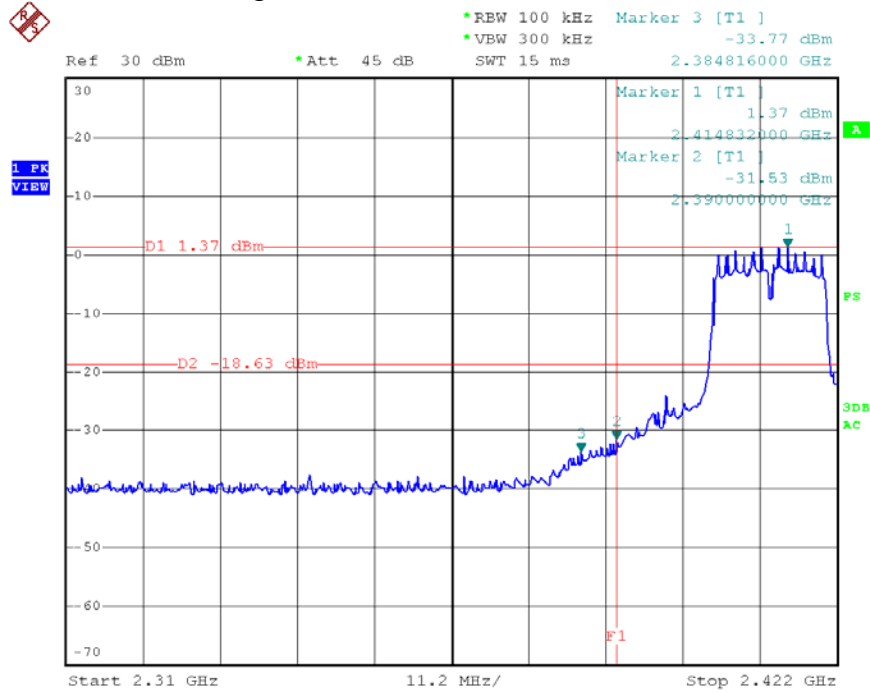

Date: 23.NOV.2013 09:29:08

Test Mode: 802.11g ---High

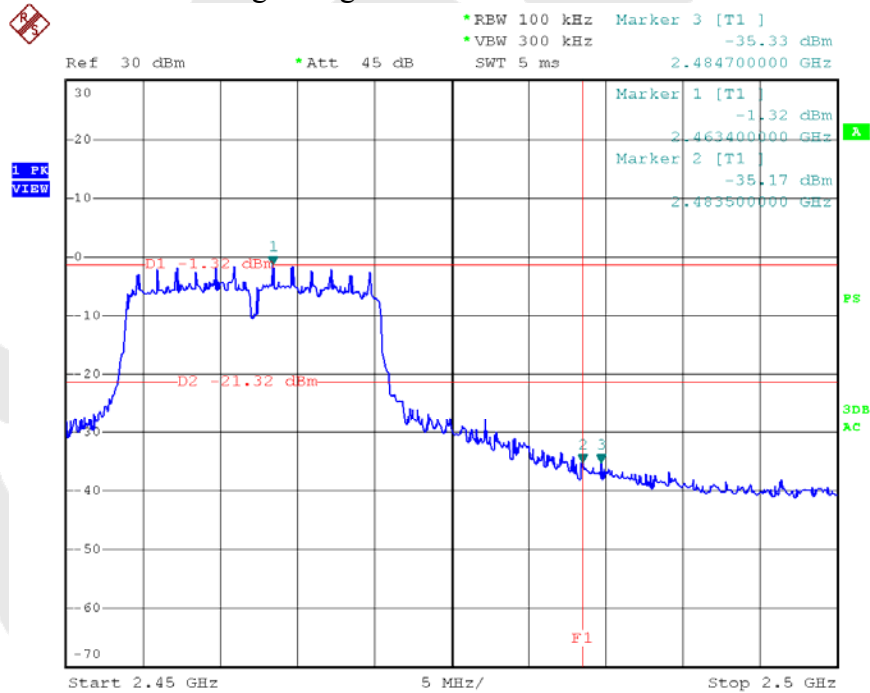

Date: 23.NOV.2013 10:04:06

Test Mode: 802.11n (HT20) ---Low

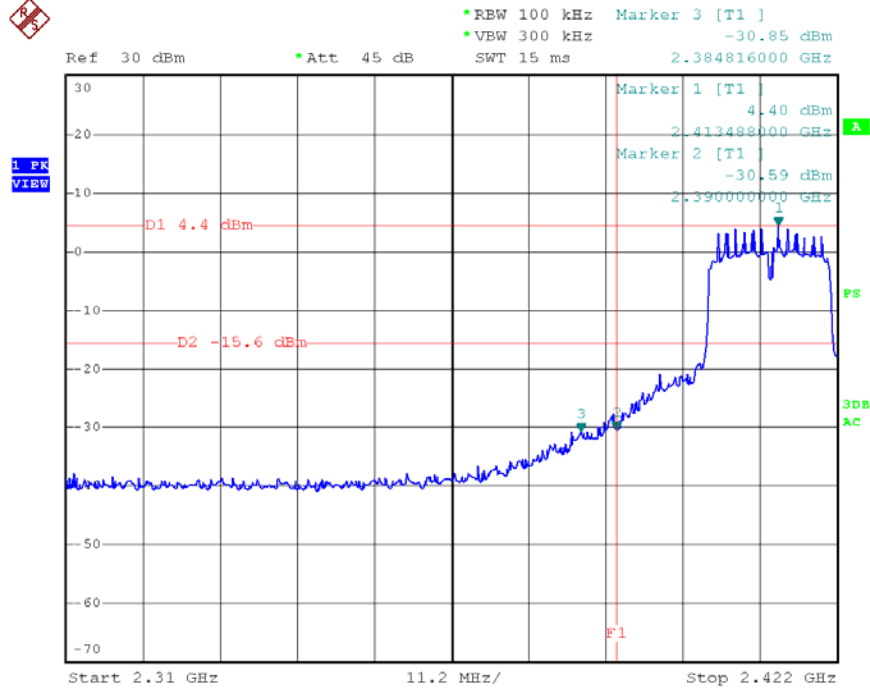

Date: 23.NOV.2013 10:00:08

Test Mode: 802.11n (HT20)---High

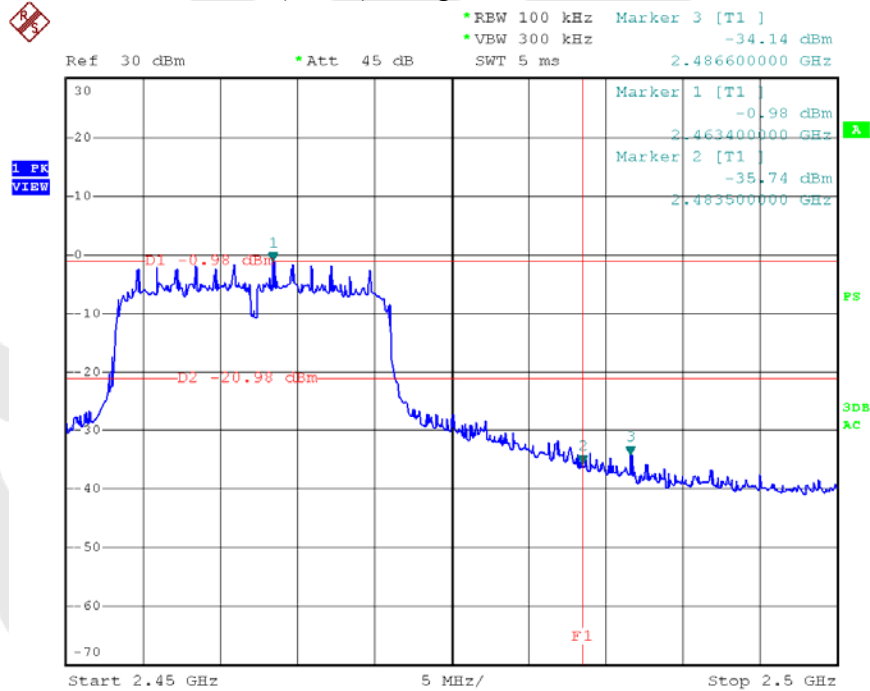

Date: 23.NOV.2013 10:04:57

Test Mode: 802.11n (HT40) ---Low

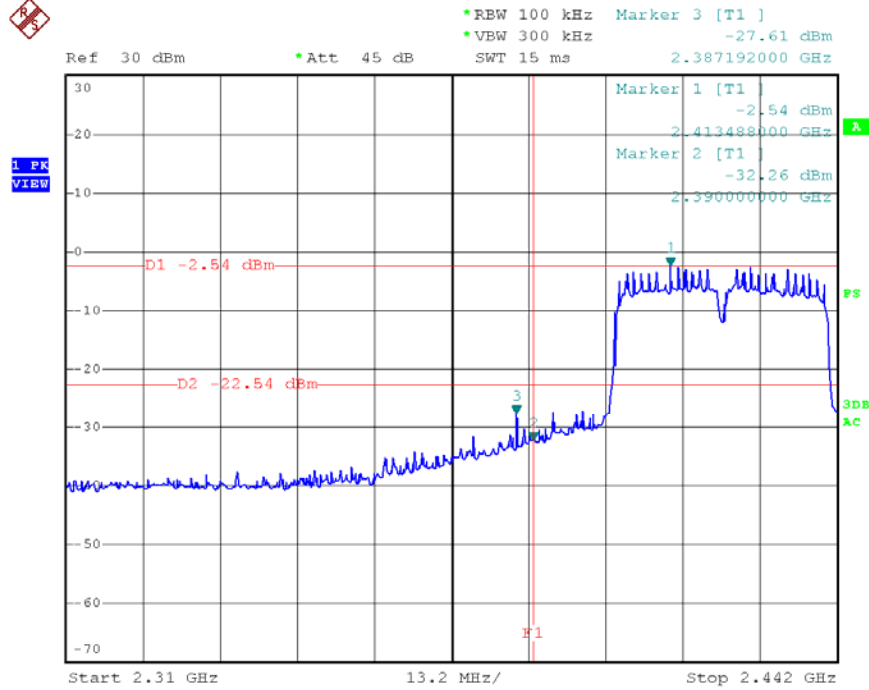

Date: 23.NOV.2013 10:01:34

Test Mode: 802.11n (HT40) ---High

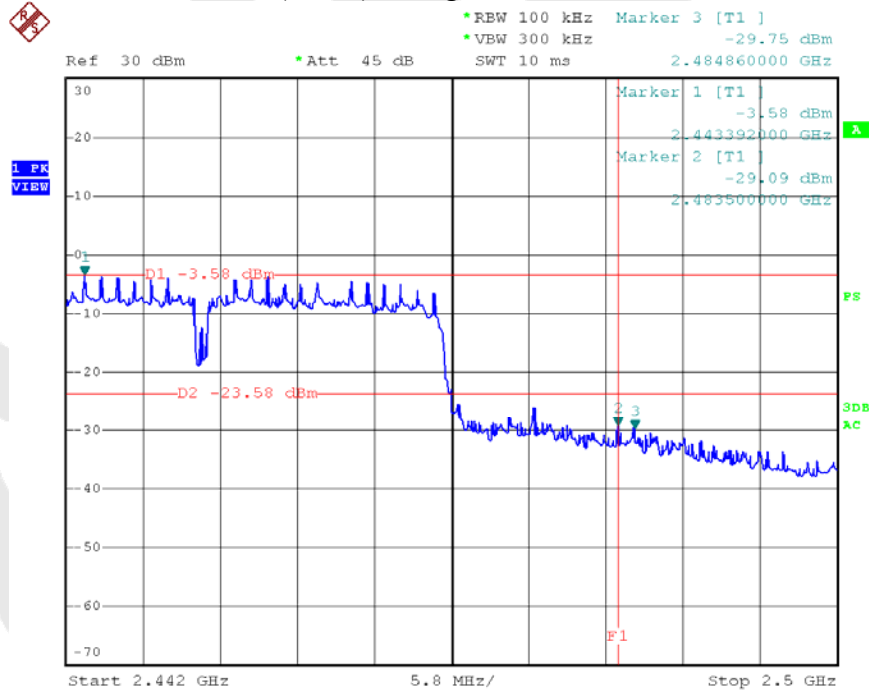

Date: 23.NOV.2013 10:06:52

The Worst Mode: 802.11b

2412MHz

Horizontal-PEAK:

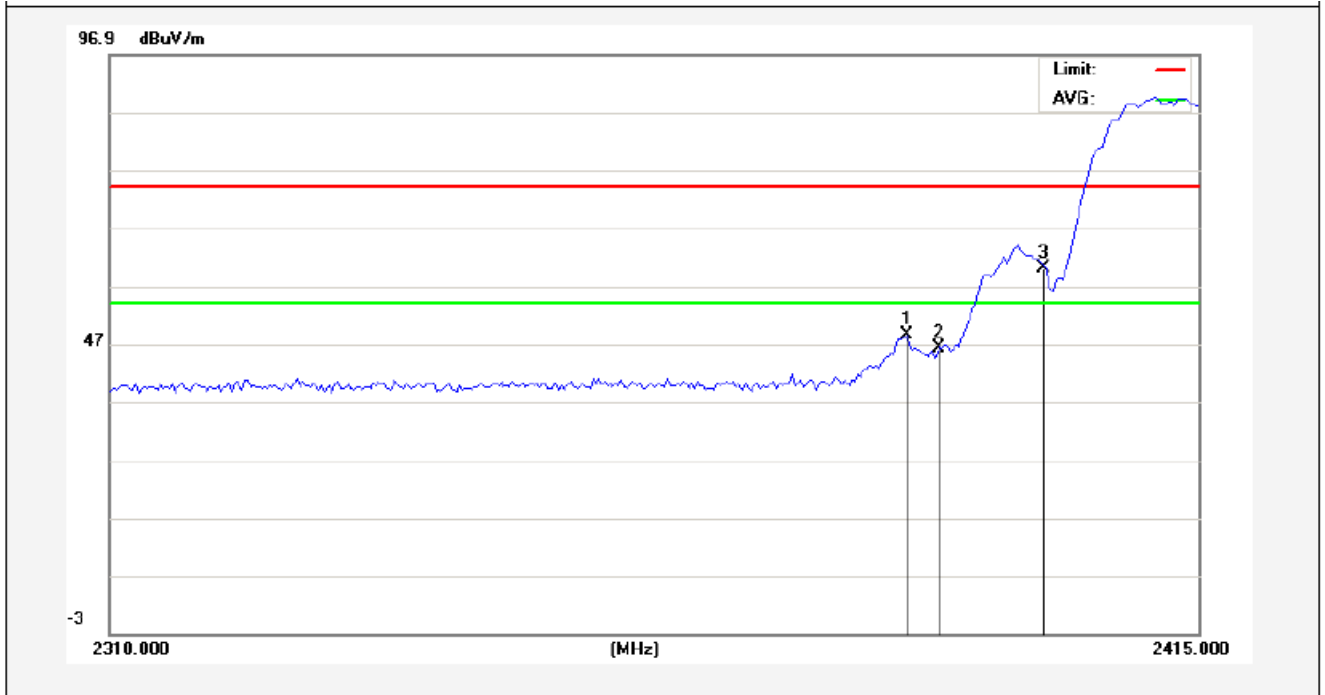

No.	Freq. (MHz)	Reading (dBuV/m)	Factor (dB/m)	Result (dBuV/m)	Limit (dBuV/)	Over Limit (dB)	Detector	Height (cm)	degree (deg)	Remark
1	2386.650	51.01	-2.52	48.49	74.00	-25.51	peak			
2	2390.000	48.83	-2.51	46.32	74.00	-27.68	peak			
3	2400.000	62.51	-2.49	60.02	74.00	-13.98	peak			

AMB

Horizontal-AV:

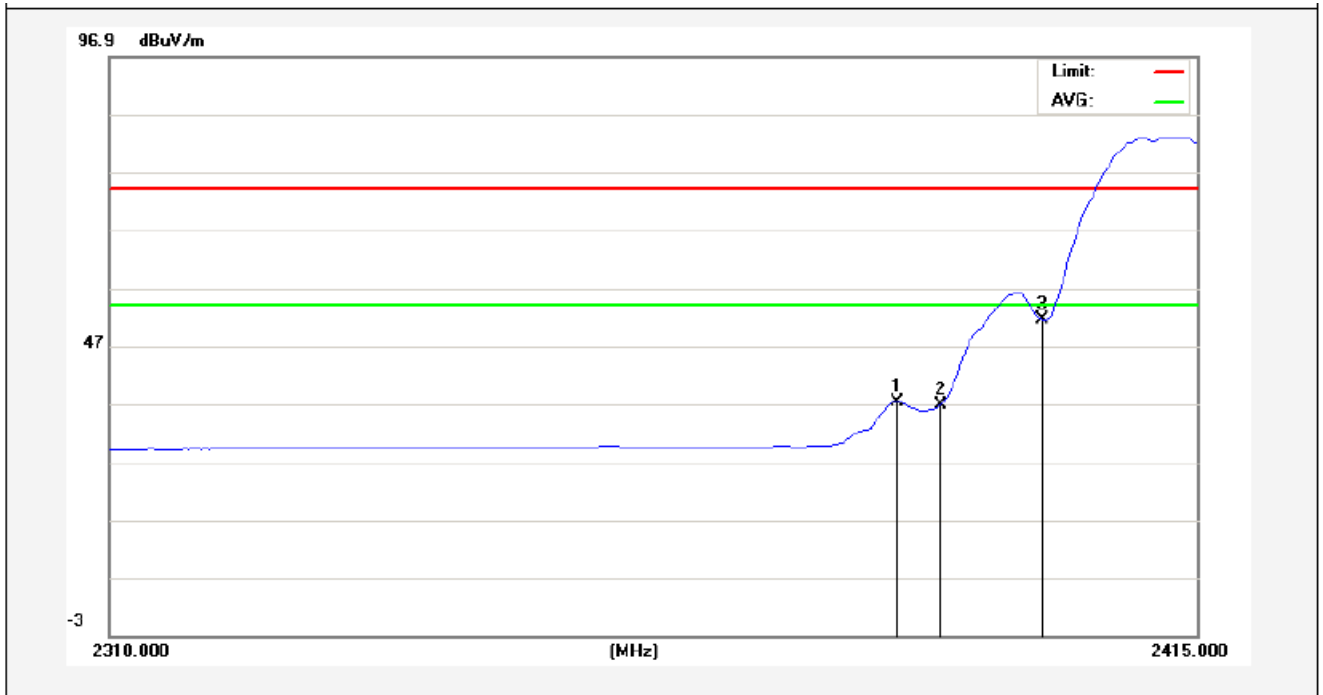

No.	Freq. (MHz)	Reading (dBuV/m)	Factor (dB/m)	Result (dBuV/m)	Limit (dBuV/)	Over Limit (dB)	Detector	Height (cm)	degree (deg)	Remark
1	2385.863	39.90	-2.52	37.38	54.00	-16.62	AVG			
2	2390.000	39.34	-2.51	36.83	54.00	-17.17	AVG			
3	2400.000	53.97	-2.49	51.48	54.00	-2.52	AVG			

Anbotek

The Worst Mode: 802.11b

2412MHz

Vertical-PEAK:

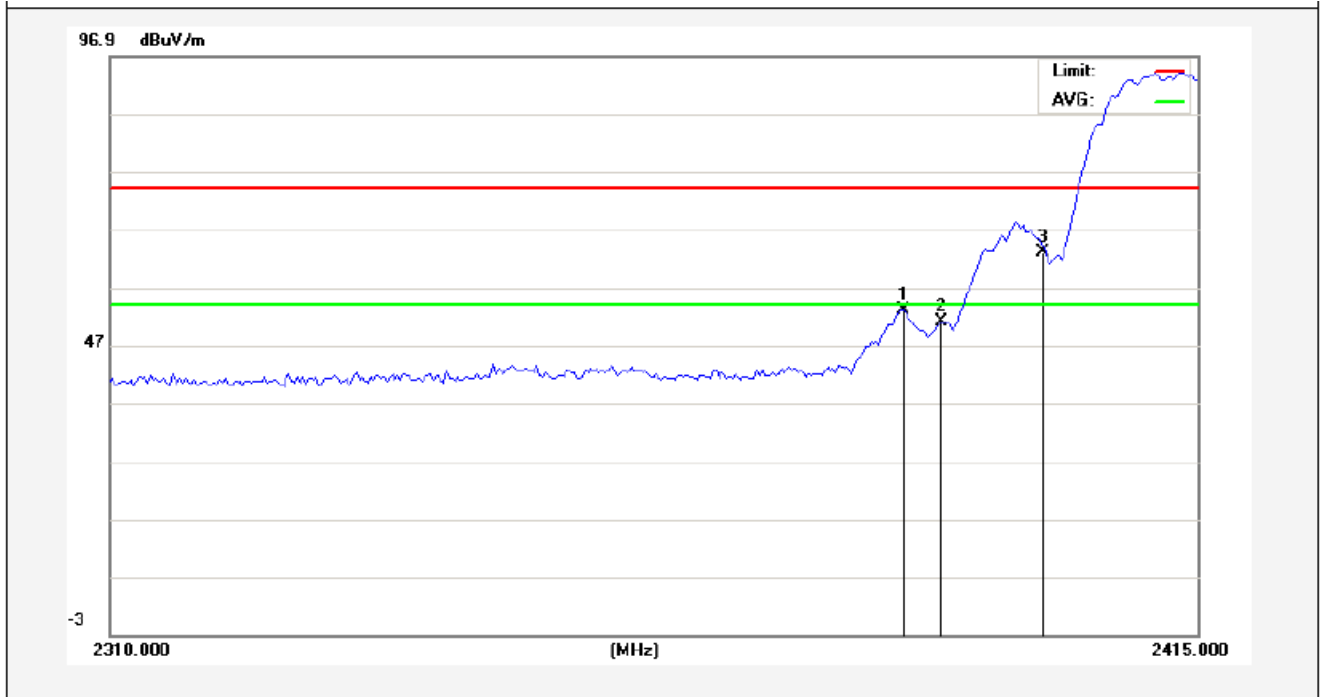

No.	Freq. (MHz)	Reading (dBuV/m)	Factor (dB/m)	Result (dBuV/m)	Limit (dBuV/)	Over Limit (dB)	Detector	Height (cm)	degree (deg)	Remark
1	2386.387	55.48	-2.52	52.96	74.00	-21.04	peak			
2	2390.000	53.56	-2.51	51.05	74.00	-22.95	peak			
3	2400.000	65.51	-2.49	63.02	74.00	-10.98	peak			

AMB

Vertical-AV:

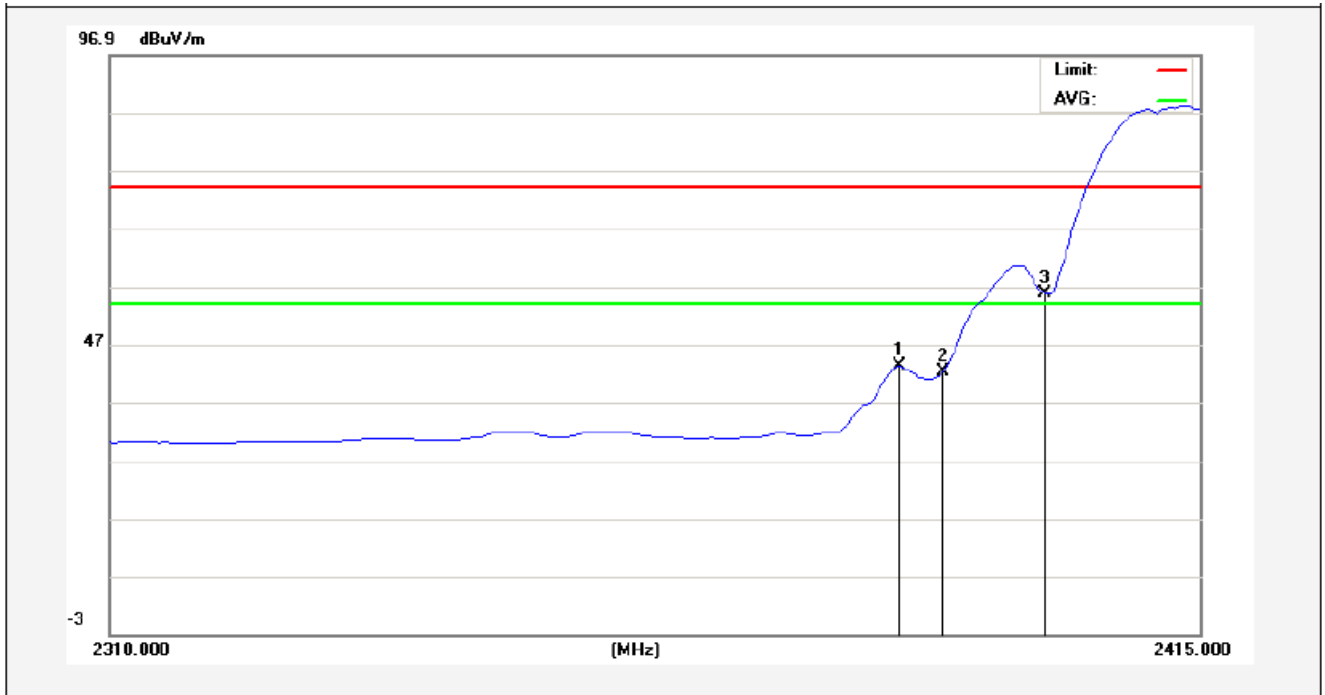

No.	Freq. (MHz)	Reading (dBuV/m)	Factor (dB/m)	Result (dBuV/m)	Limit (dBuV/)	Over Limit (dB)	Detector	Height (cm)	degree (deg)	Remark
1	2385.863	45.69	-2.52	43.17	54.00	-10.83	AVG			
2	2390.000	44.71	-2.51	42.20	54.00	-11.80	AVG			
3	2400.000	58.20	-2.49	55.71	54.00	1.71	AVG			

Anbotek

The Worst Mode: 802.11b

2462MHz

Horizontal-PEAK:

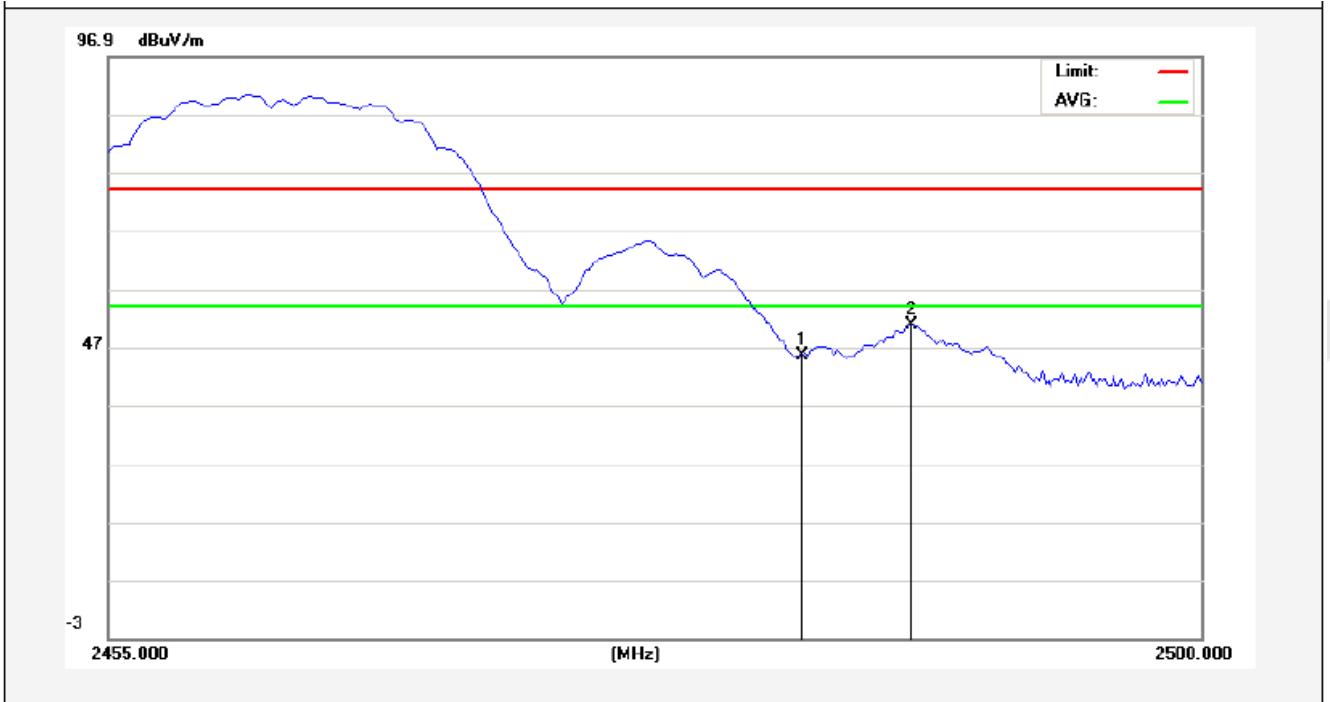

No.	Freq. (MHz)	Reading (dBuV/m)	Factor (dB/m)	Result (dBuV/m)	Limit (dBuV/)	Over Limit (dB)	Detector	Height (cm)	degree (deg)	Remark
1	2483.500	47.89	-2.31	45.58	74.00	-28.42	peak			
2	2488.075	53.00	-2.30	50.70	74.00	-23.30	peak			

Anbotek

Horizontal-AV:

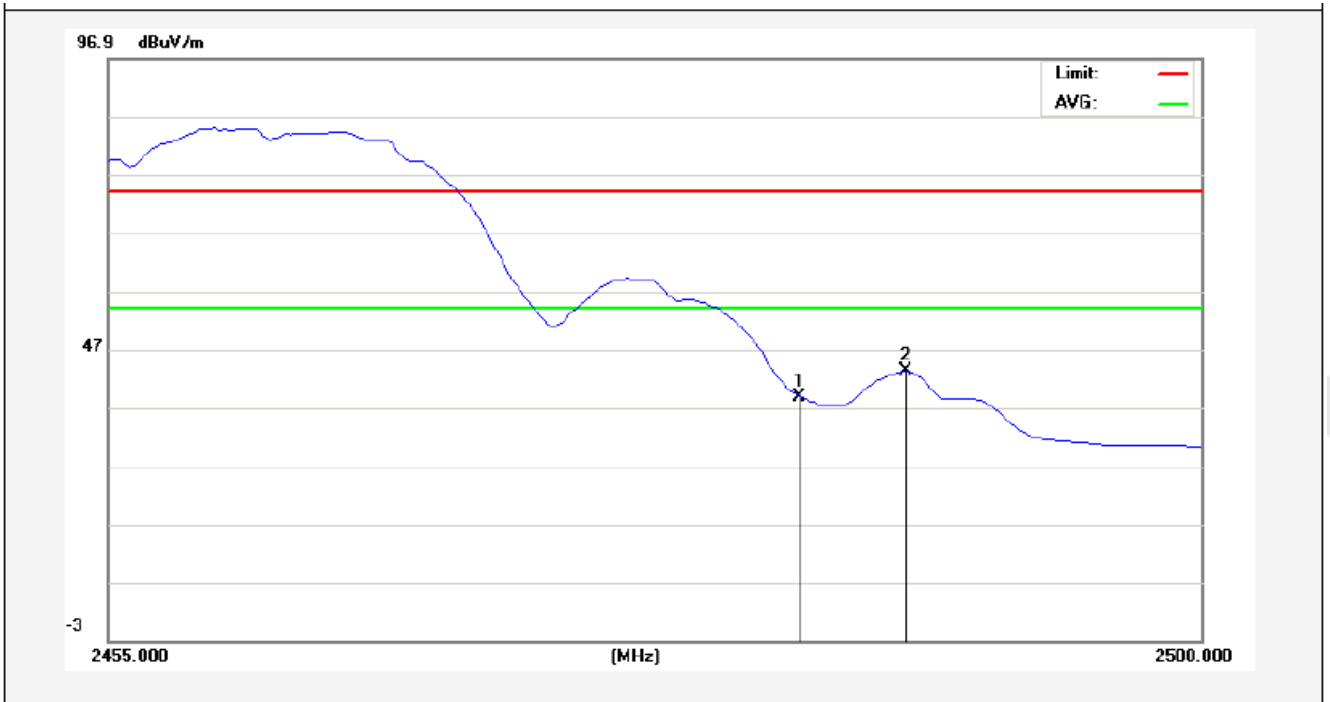

No.	Freq. (MHz)	Reading (dBuV/m)	Factor (dB/m)	Result (dBuV/m)	Limit (dBuV/)	Over Limit (dB)	Detector	Height (cm)	degree (deg)	Remark
1	2483.500	40.99	-2.31	38.68	54.00	-15.32	AVG			
2	2487.850	45.53	-2.30	43.23	54.00	-10.77	AVG			

Anbotek

The Worst Mode: 802.11b

2462MHz

Vertical-PEAK:

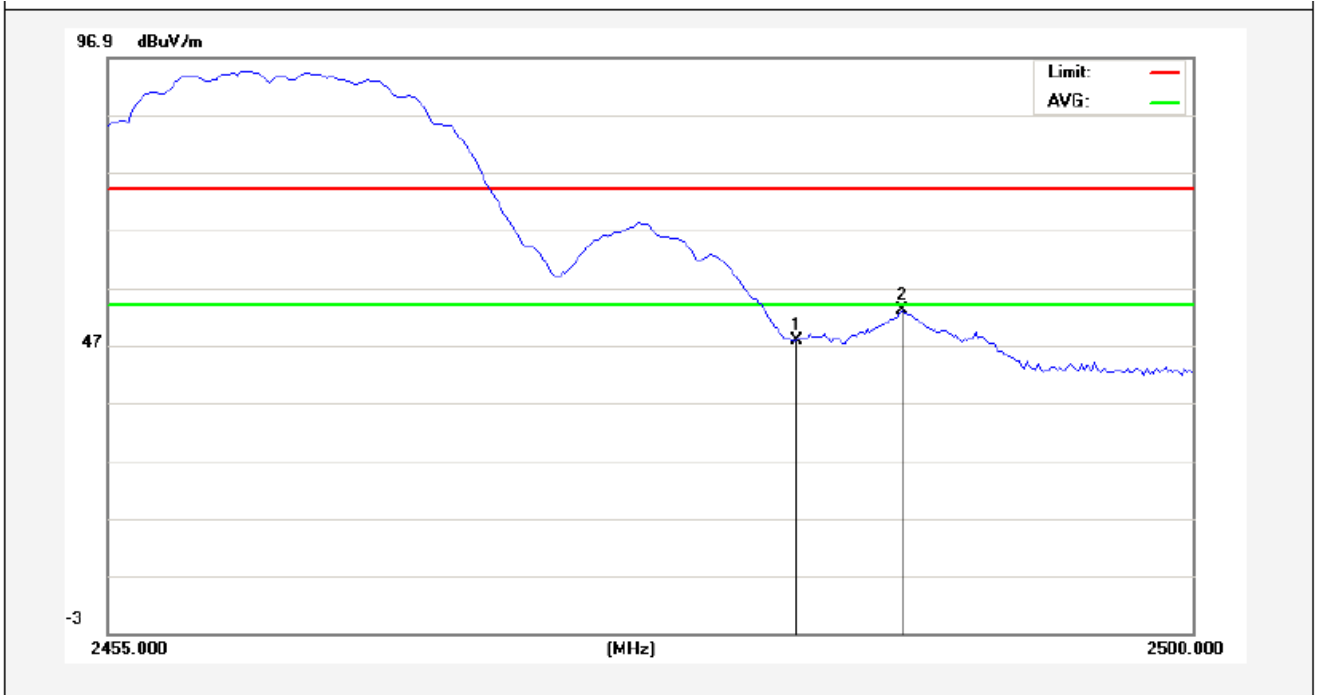

No.	Freq. (MHz)	Reading (dBuV/m)	Factor (dB/m)	Result (dBuV/m)	Limit (dBuV/)	Over Limit (dB)	Detector	Height (cm)	degree (deg)	Remark
1	2483.500	50.02	-2.31	47.71	74.00	-26.29	peak			
2	2487.963	55.38	-2.30	53.08	74.00	-20.92	peak			

Anbotek

Vertical-AV:

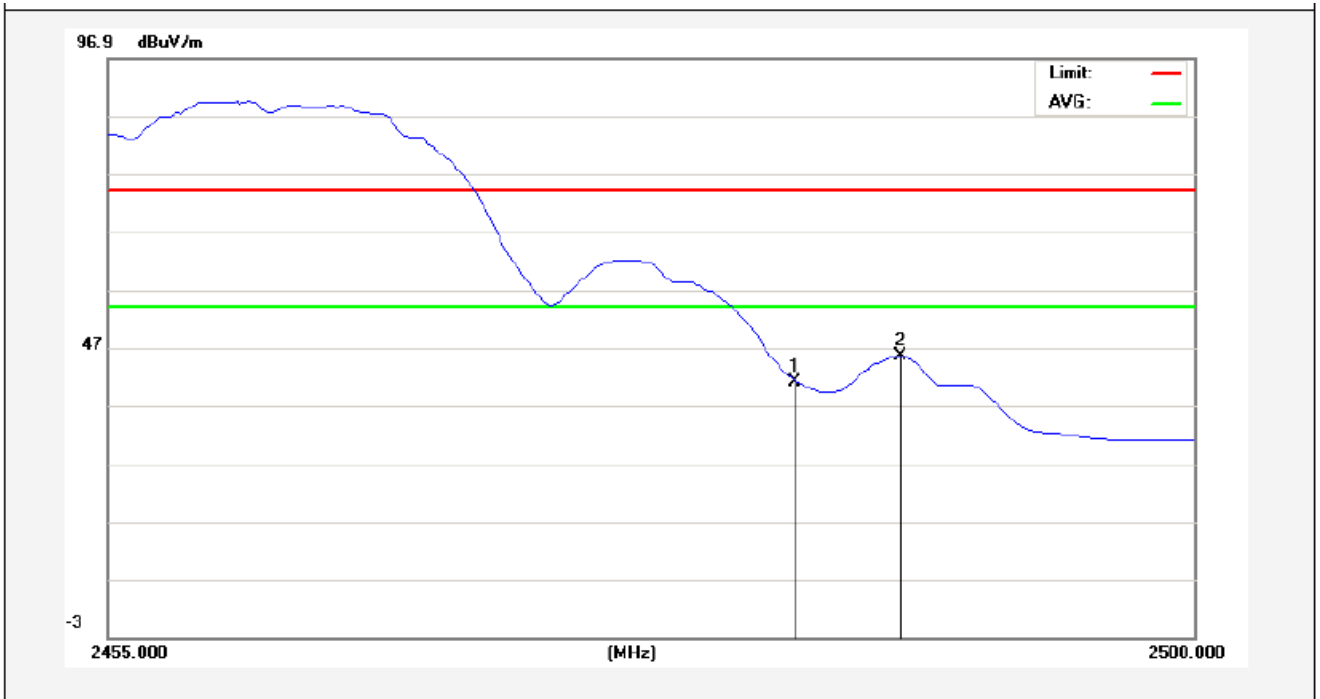

No.	Freq. (MHz)	Reading (dBuV/m)	Factor (dB/m)	Result (dBuV/m)	Limit (dBuV/)	Over Limit (dB)	Detector	Height (cm)	degree (deg)	Remark
1	2483.500	43.31	-2.31	41.00	54.00	-13.00	AVG			
2	2487.850	47.77	-2.30	45.47	54.00	-8.53	AVG			

Anbotek

4.5. Peak Power Spectral Density

a. Limit

1. For direct sequence systems, the peak power spectral density conducted from the intentional radiator to the antenna shall not be greater than 8dBm in any 3kHz band during any time interval of continuous transmission.
2. The direct sequence operating of the hybrid system, with the frequency hopping operation turned off, shall comply with the power density requirements of paragraph (d) of this section.

b. Test Procedure

1. Place the EUT on the table and set it in transmitting mode. Remove the antenna from the EUT and then connect a low loss RF cable from the antenna port to the spectrum analyzer.
2. Set the spectrum analyzer as RBW = 3kHz, VBW = 10kHz, Span = 1.5MHz, Sweep=500s
3. Record the max. reading.
4. Repeat the above procedure until the measurements for all frequencies are completed.

c. Test Equipment

Same as the equipment listed in 4.2.

d. Test Setup

See 4.1

e. Test Results

Pass

f. Test Data

Please refer to the following data.

g. Test Plot See the following pages

Test mode: IEEE 802.11b

Channel	Frequency (MHz)	PPSD (dBm/3KHz)	Σ PPSD (dBm/3KHz)	Limit (dBm)	Result
Low	2412	0.62	-	8.00	Pass
Mid	2437	-0.52	-		Pass
High	2462	-2.54	-		Pass

Test mode: IEEE 802.11g

Channel	Frequency (MHz)	PPSD (dBm)	Σ PPSD (dBm)	Limit (dBm)	Result
Low	2412	-15.02	-	8.00	Pass
Mid	2437	-16.06	-		Pass
High	2462	-15.46	-		Pass

Test mode: IEEE 802.11n (HT20)

Channel	Frequency (MHz)	PPSD (dBm/3KHz)	Σ PPSD (dBm/3KHz)	Limit (dBm)	Result
Low	2412	-14.67	-	8.00	Pass
Mid	2437	-14.90	-		Pass
High	2462	-15.69	-		Pass

Test mode: IEEE 802.11n (HT40)

Channel	Frequency (MHz)	PPSD (dBm/3KHz)	Σ PPSD (dBm/3KHz)	Limit (dBm)	Result
Low	2422	-14.07	-	8.00	Pass
Mid	2437	-14.84	-		Pass
High	2452	-15.94	-		Pass

802.11 b CH--Low

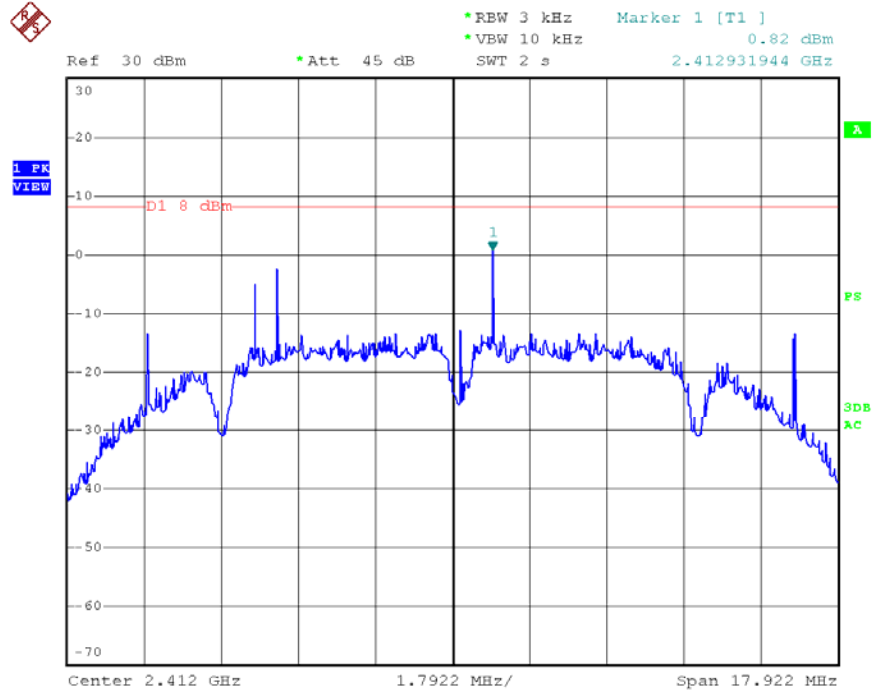

Date: 23.NOV.2013 10:33:47

802.11 b CH--Mid

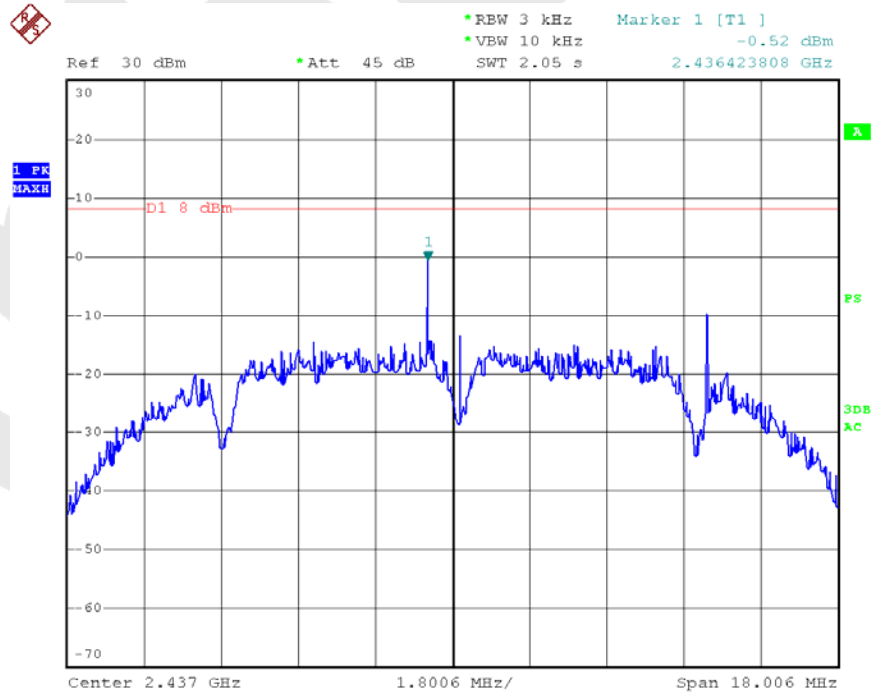

Date: 23.NOV.2013 10:34:29

802.11 b CH--High

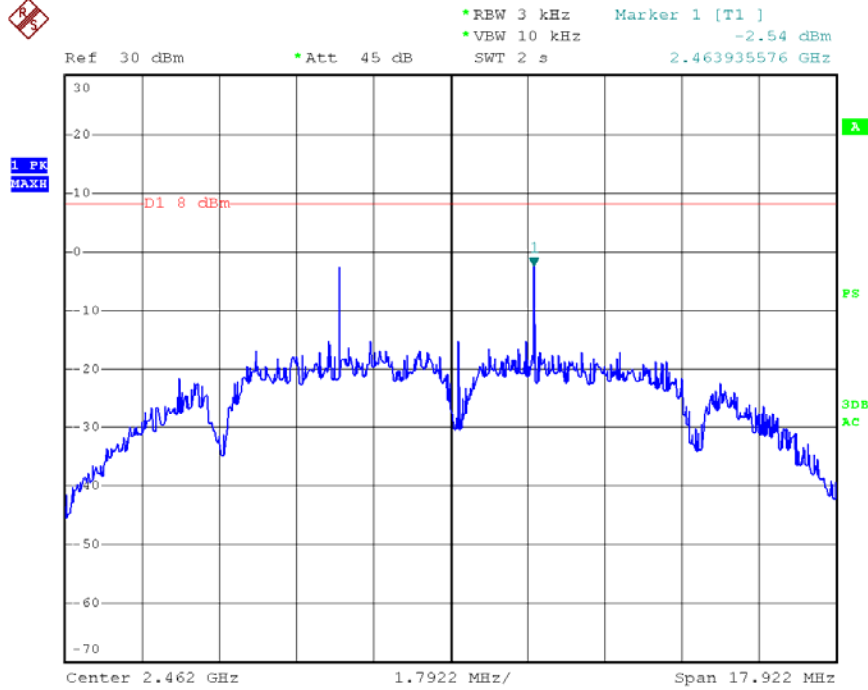

Date: 23.NOV.2013 10:35:01

802.11g CH--Low

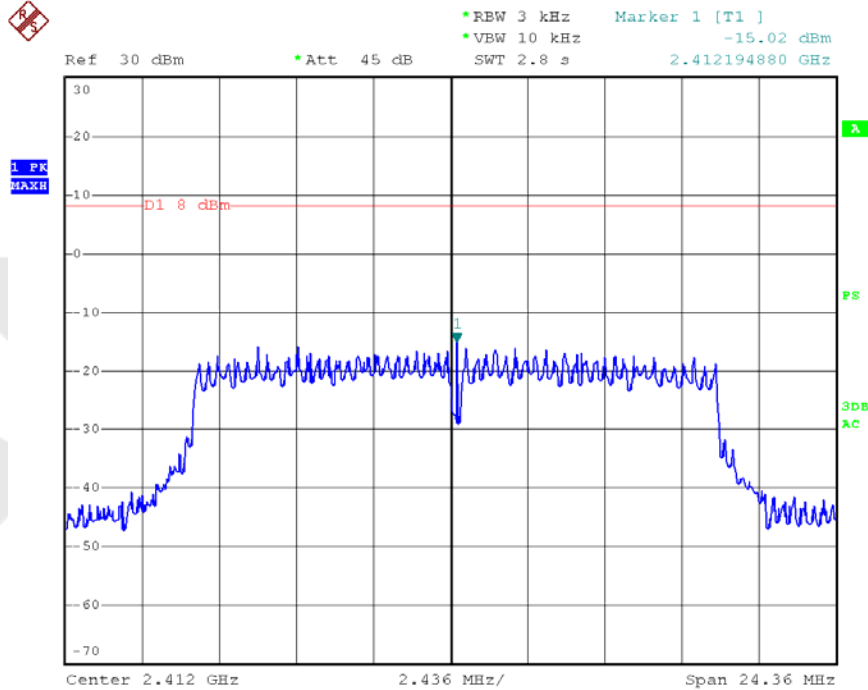

Date: 23.NOV.2013 10:35:42

802.11g CH--Mid

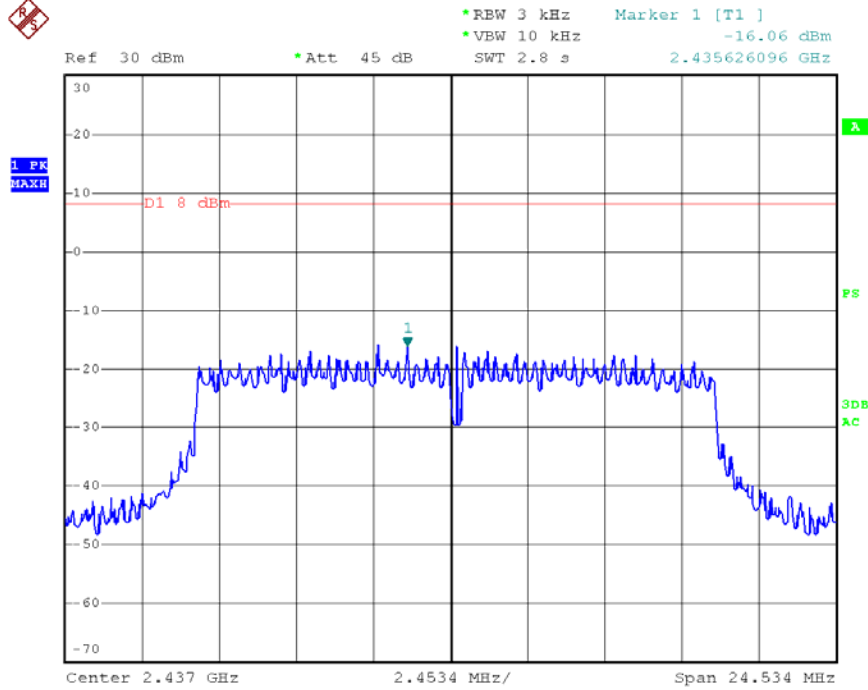

Date: 23.NOV.2013 10:36:17

802.11g CH--High

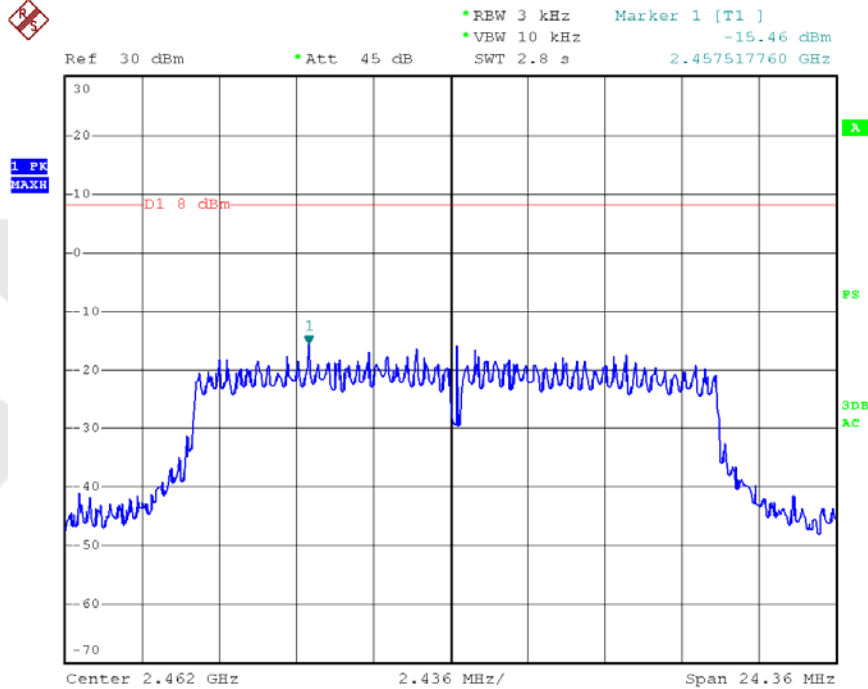

Date: 23.NOV.2013 10:36:50

802.11n (HT20) CH—Low

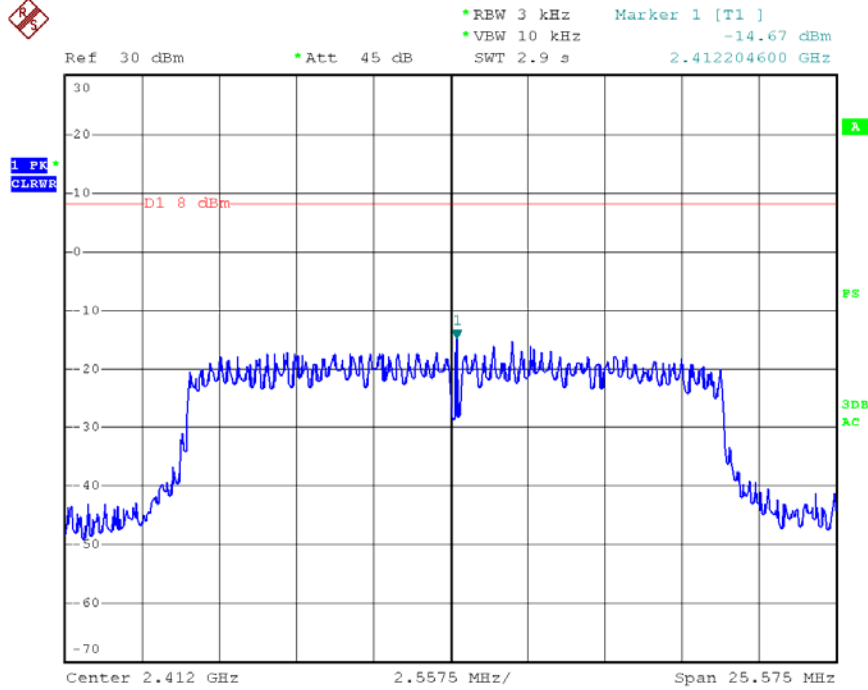

Date: 23.NOV.2013 10:37:27

802.11n (HT20) CH—Mid

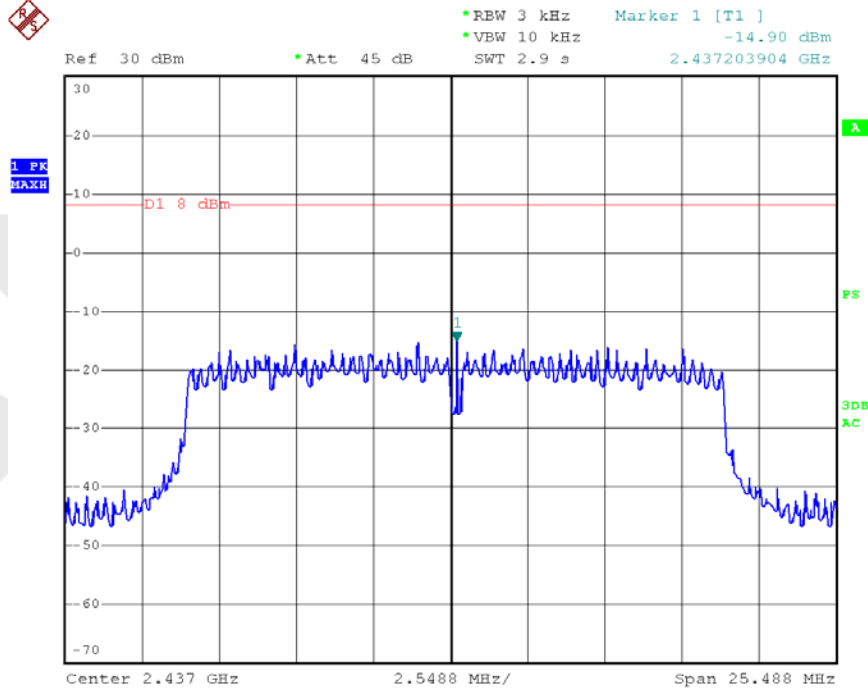

Date: 23.NOV.2013 10:38:12

802.11n (HT20) CH—High

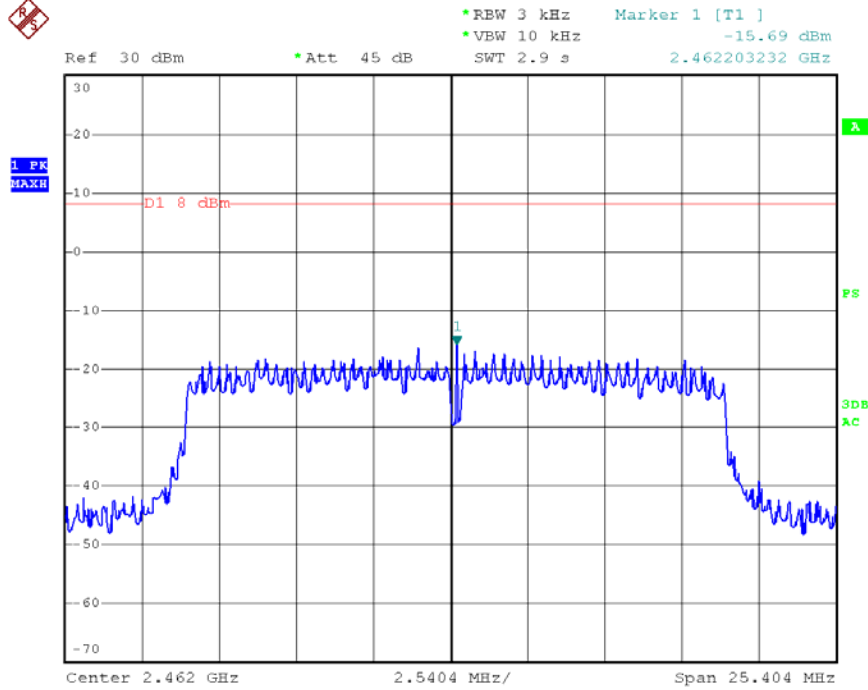

Date: 23.NOV.2013 10:38:49

802.11n (HT40) CH—Low

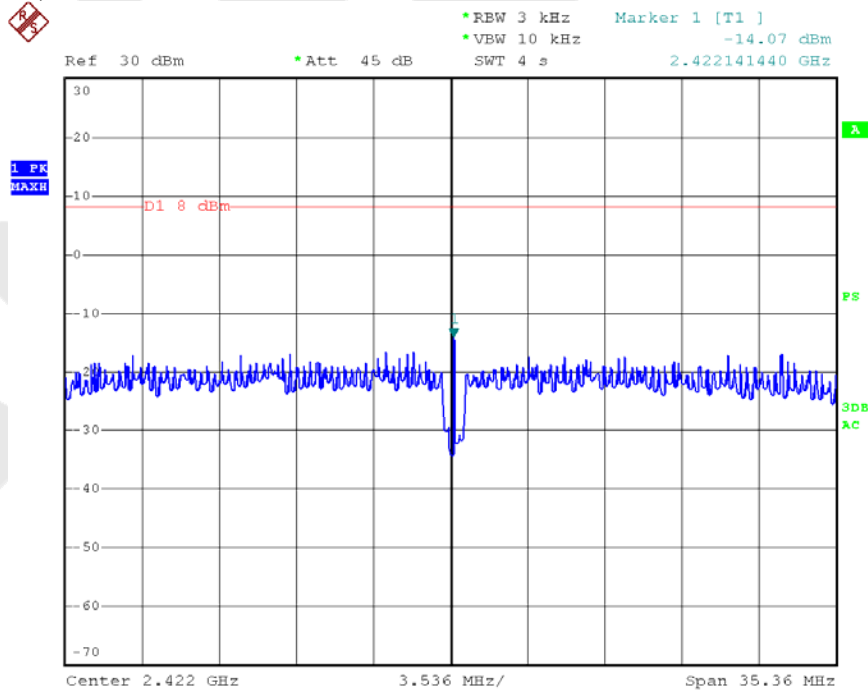

Date: 23.NOV.2013 10:40:05

802.11n (HT40) CH—Mid

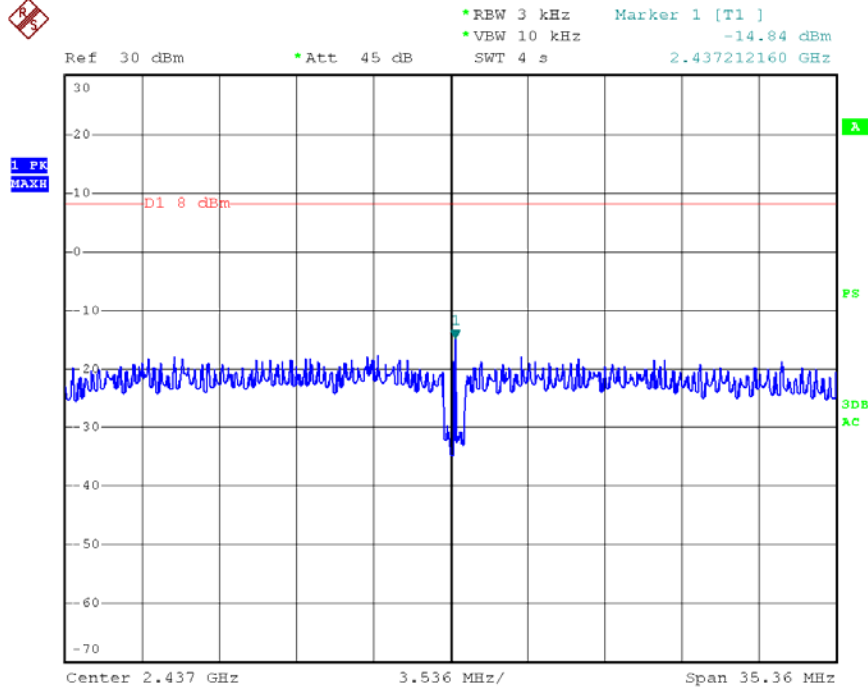

Date: 23.NOV.2013 10:40:38

802.11n (HT40) CH—High

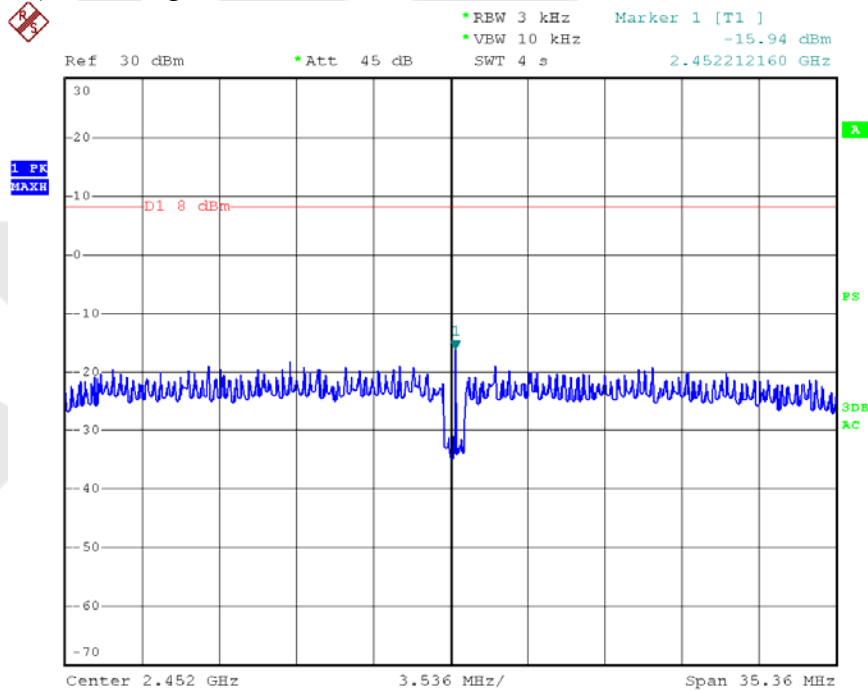

Date: 23.NOV.2013 10:41:42

4.6. Radiated Emissions

4.6.1.1. Test Limits (< 30 MHz)

Frequency (MHz)	Field Strength (microvolts/meter)	Measurement Distance (meter)
0.009-0.490	2400/F(kHz)	300
0.490-1.705	24000/F(kHz)	30
1.705-30.0	30	30

4.6.1.2. Test Limits (\geq 30 MHz)

FIELD STRENGTH of Fundamental: @3M	FIELD STRENGTH of Harmonics	S15.209 30 - 88 MHz	40 dBuV/m
902-928 MHz		88 - 216 MHz	43.5
2.4-2.4835 GHz		216 - 960 MHz	46
94 dB μ V/m @3m	54 dB μ V/m @3m	ABOVE 960 MHz	54dBuV/m

In any 100 kHz bandwidth outside the frequency band in which the spread spectrum or digitally modulated intentional radiator is operating, the radio frequency power that is produced by the intentional radiator shall be at least 20 dB below that in the 100 kHz bandwidth within the band that contains the highest level of the desired power, based on either an RF conducted or a radiated measurement. Attenuation below the general limits specified in Section 15.209(a) is not required. In addition, radiated emissions which fall in the restricted bands, as defined in Section 15.205(a), must also comply with the radiated emission limits specified in Section 15.209(a) (see Section 15.205(c)).

Test Equipment

Item	Equipment	Manufacturer	Model No.	Serial No.	Last Cal.	Cal. Interval
1.	Preamplifier	Instruments corporation	EMC011830	980100	Aug. 09, 2013	1 Year
2.	EMI Test Receiver	Rohde & Schwarz	ESPI	101604	Apr. 23, 2013	1 Year
3.	Double Ridged Horn Antenna	Instruments corporation	GTH-0118	351600	Aug. 09, 2013	3 Year
4.	Bilog Broadband Antenna	Schwarzbeck	VULB9163	VULB 9163-289	Apr. 23, 2013	3 Year
5.	Pre-amplifier	SONOMA	310N	186860	Apr. 23, 2013	1 Year
6.	EMI Test Software EZ-EMC	SHURPLE	N/A	N/A	N/A	N/A

4.6.2. Test Configuration:

4.6.2.1. 9k to 30MHz emissions:

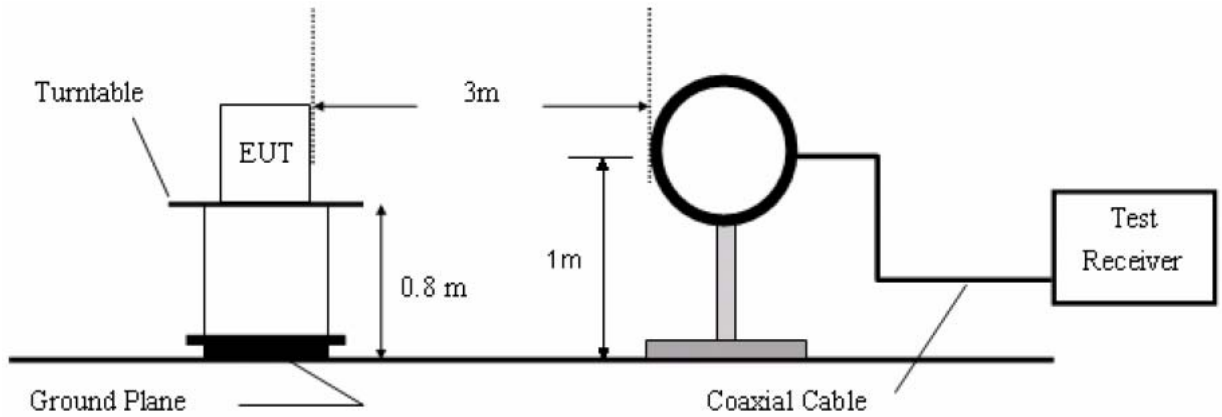

4.6.2.2. 30M to 1G emissions:

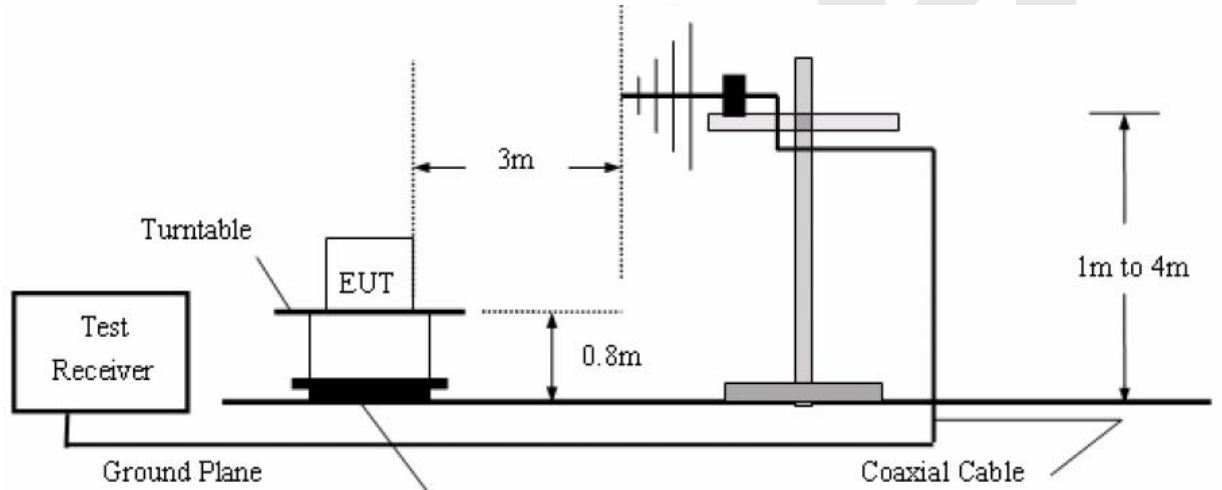

4.6.2.3. 1G to 40G emissions:

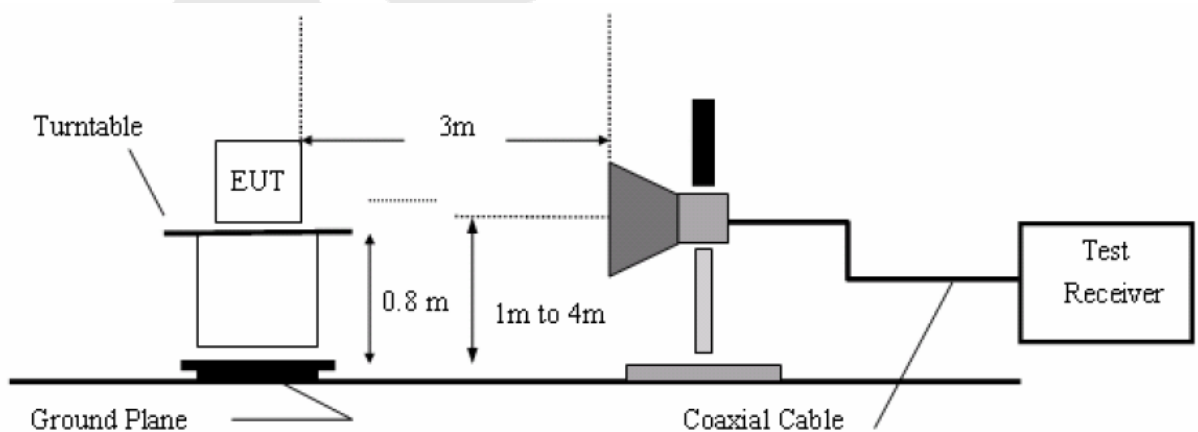

4.6.3. Test Procedure

The EUT is placed on a turn table which is 0.8 meter high above the ground. The turn table can rotate 360 degrees to determine the position of the maximum emission level. The EUT is set 3 meters away from the receiving antenna which is mounted on a antenna tower. The antenna can be moved up and down from 1 to 4 meters to find out the maximum emission level. Both horizontal and vertical polarization of the antenna are set on test.

Measurements are made on 9KHz to 30MHz and 30MHz to 26GHz range with the transmitter set to the lowest, middle, and highest channels.

All readings from 30MHz to 1GHz are quasi-peak values with a resolution bandwidth of 120kHz. All reading are above 1GHz, peak & average values with a resolution bandwidth of 1MHz.

The EUT is tested in 9*6*6 Chamber.

The test results are listed in Section 4.6.4.

4.6.4. Test Results

Please refer to the following pages.

Job No.:	AT1311756F	Polarization:	Horizontal
Standard:	(RE)FCC PART15 C_3m	Power Source:	AC 120V/60Hz for adapter
Test item:	Radiation Test	Test By:	Kebo Zhang
Temp.(C)/Hum.(%RH):	24.3(C)/55%RH	Distance:	3m
Note:	On		

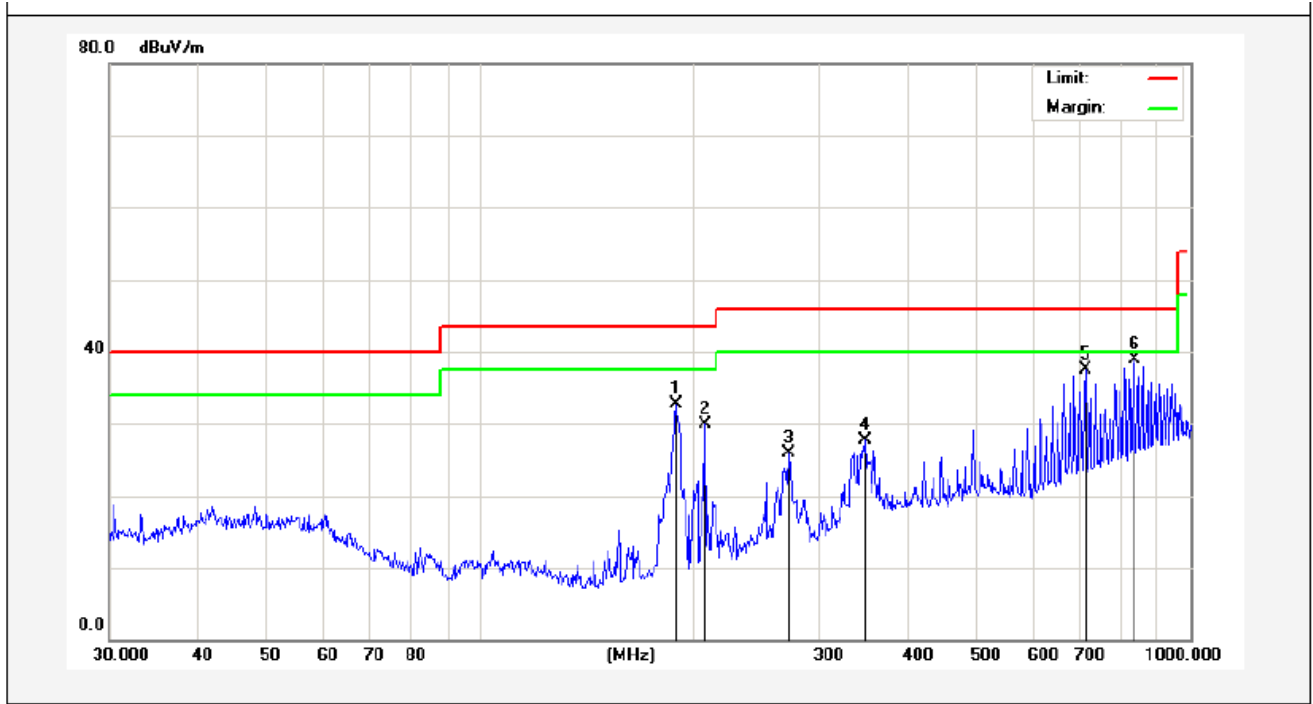

No.	Freq. (MHz)	Reading (dBuV/m)	Factor (dB/m)	Result (dBuV/m)	Limit (dBuV/)	Over Limit (dB)	Detector	Height (cm)	degree (deg)	Remark
1	188.4125	53.81	-21.07	32.74	43.50	-10.76	peak			
2	207.1226	50.47	-20.60	29.87	43.50	-13.63	peak			
3	271.3246	44.37	-18.56	25.81	46.00	-20.19	peak			
4	348.0274	41.84	-14.05	27.79	46.00	-18.21	peak			
5	711.6734	45.69	-8.24	37.45	46.00	-8.55	peak			
6	833.3171	44.75	-5.90	38.85	46.00	-7.15	peak			

Job No.:	AT1311756F	Polarization:	Vertical
Standard:	(RE)FCC PART15 C_3m	Power Source:	AC 120V/60Hz for adapter
Test item:	Radiation Test	Test By:	Kebo Zhang
Temp.(C)/Hum.(%RH):	24.3(C)/55%RH	Distance:	3m
Note:	On		

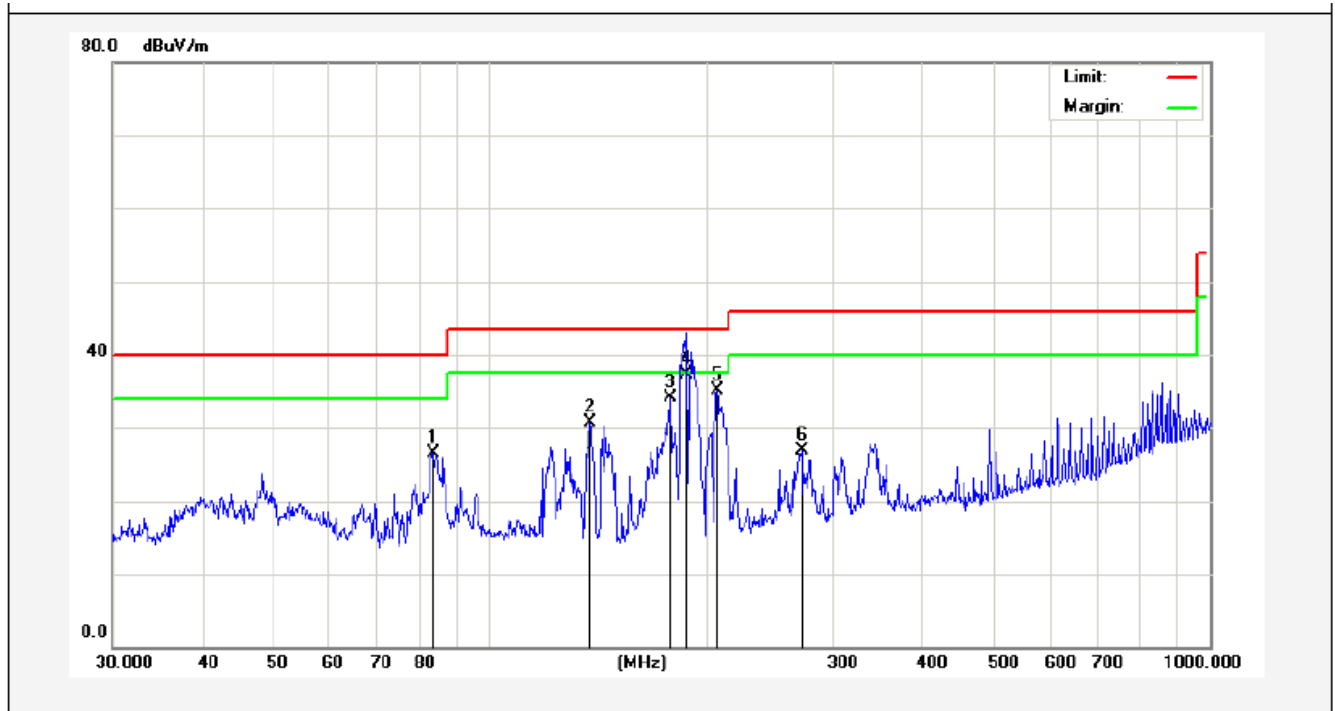

No.	Freq. (MHz)	Reading (dBuV/m)	Factor (dB/m)	Result (dBuV/m)	Limit (dBuV/)	Over Limit (dB)	Detector	Height (cm)	degree (deg)	Remark
1	83.8156	45.26	-18.73	26.53	40.00	-13.47	peak			
2	137.9028	49.05	-18.34	30.71	43.50	-12.79	peak			
3	178.7584	51.07	-16.94	34.13	43.50	-9.37	peak			
4	187.8730	53.49	-16.13	37.36	43.50	-6.14	QP	100	0	
5	207.1226	50.68	-15.60	35.08	43.50	-8.42	peak			
6	271.3246	41.61	-14.69	26.92	46.00	-19.08	peak			

Job No.:	AT1311756F	Polarization:	Horizontal
Standard:	(RE)FCC PART15 C_3m	Power Source:	AC 120V/60Hz for adapter
Test item:	Radiation Test	Test By:	Rock Zeng
Temp.(C)/Hum.(%RH):	24.3(C)/55%RH	Distance:	3m
Note:	802.11b(2412Mhz)		

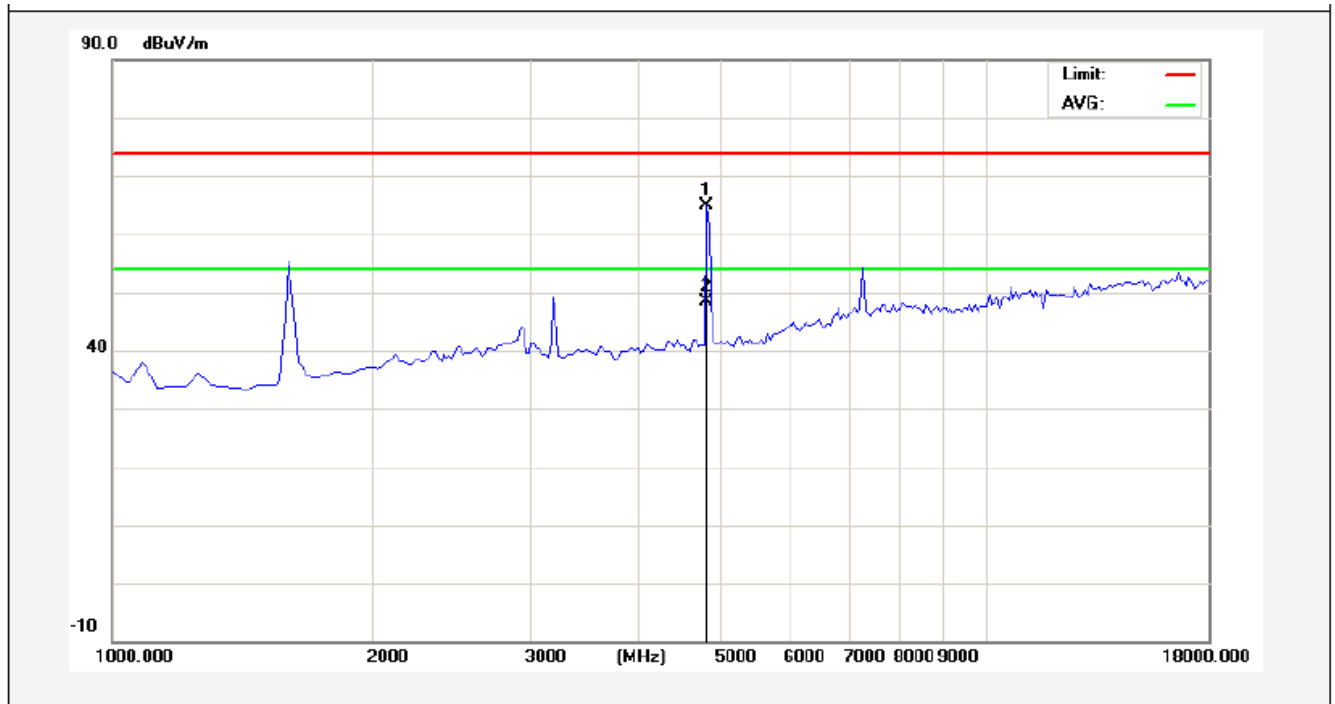

No.	Freq. (MHz)	Reading (dBuV/m)	Factor (dB/m)	Result (dBuV/m)	Limit (dBuV/)	Over Limit (dB)	Detector	Height (cm)	degree (deg)	Remark
1	4825.000	61.57	3.34	64.91	74.00	-9.09	peak			
2	4825.000	45.01	3.34	48.35	54.00	-5.65	AVG			

Job No.:	AT1311756F	Polarization:	Vertical
Standard:	(RE)FCC PART15 C_3m	Power Source:	AC 120V/60Hz for adapter
Test item:	Radiation Test	Test By:	Rock Zeng
Temp.(C)/Hum.(%RH):	24.3(C)/55%RH	Distance:	3m
Note:	802.11b(2412Mhz)		

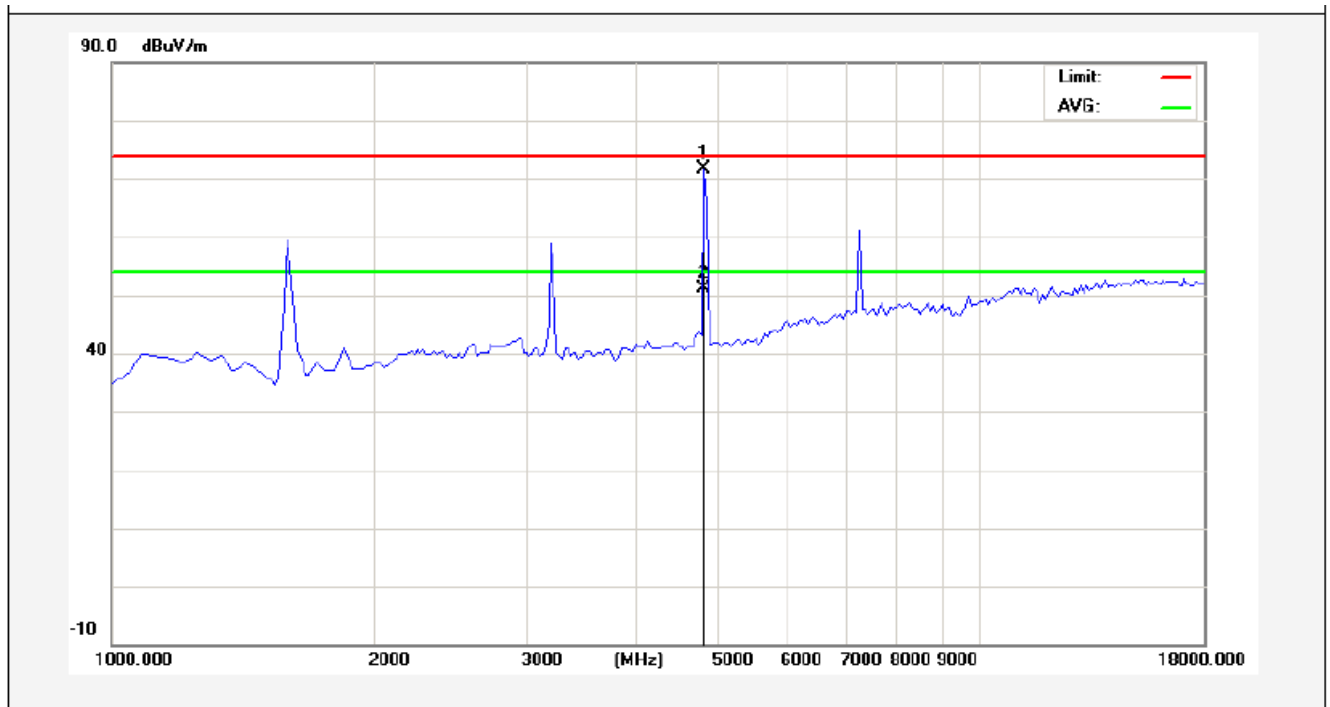

No.	Freq. (MHz)	Reading (dBuV/m)	Factor (dB/m)	Result (dBuV/m)	Limit (dBuV/)	Over Limit (dB)	Detector	Height (cm)	degree (deg)	Remark
1	4825.000	68.33	3.34	71.67	74.00	-2.33	peak			
2	4825.000	47.73	3.34	51.07	54.00	-2.93	AVG			

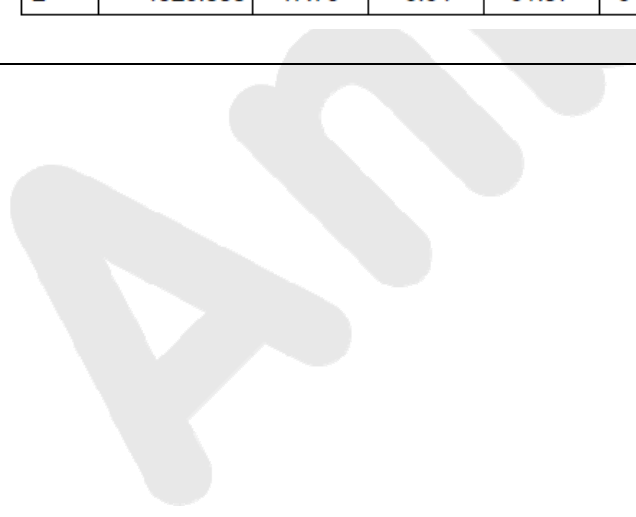

Job No.:	AT1311756F	Polarization:	Horizontal
Standard:	(RE)FCC PART15 C_3m	Power Source:	AC 120V/60Hz for adapter
Test item:	Radiation Test	Test By:	Rock Zeng
Temp.(C)/Hum.(%RH):	24.3(C)/55%RH	Distance:	3m
Note:	802.11b(2437Mhz)		

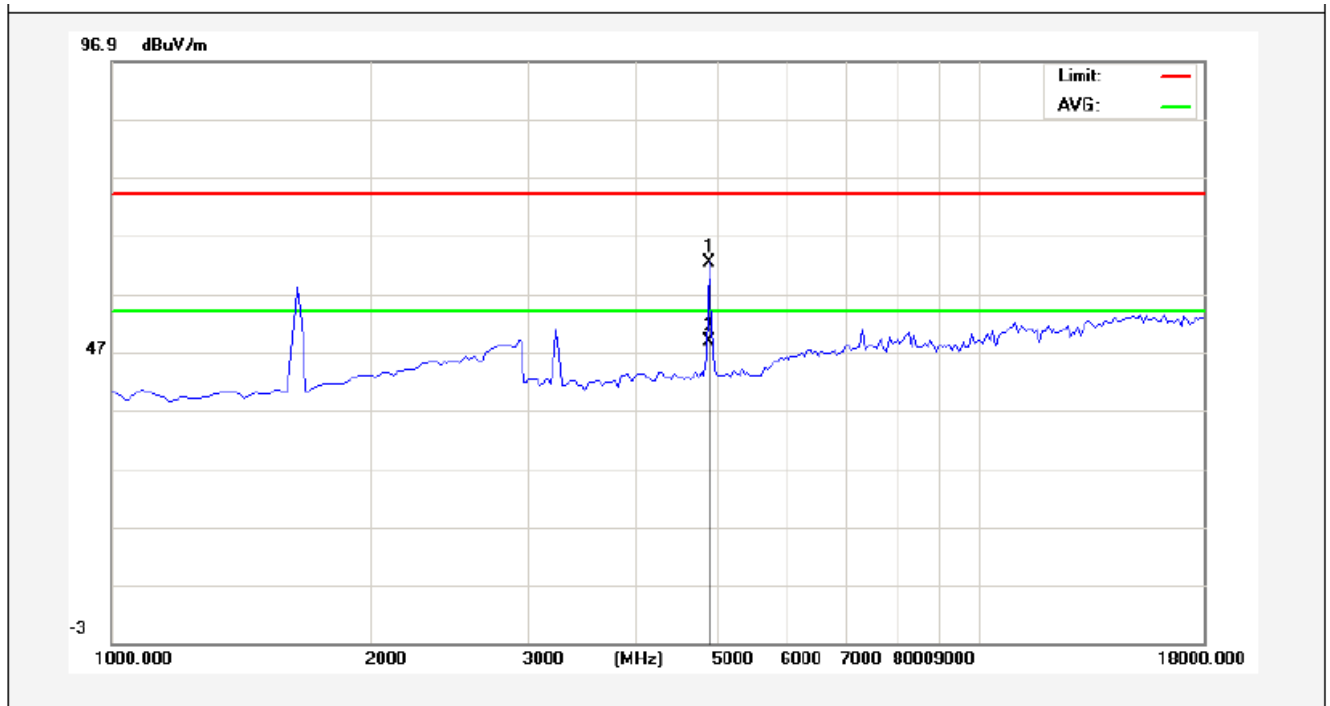

No.	Freq. (MHz)	Reading (dBuV/m)	Factor (dB/m)	Result (dBuV/m)	Limit (dBuV/)	Over Limit (dB)	Detector	Height (cm)	degree (deg)	Remark
1	4867.500	58.99	3.41	62.40	74.00	-11.60	peak			
2	4867.500	45.44	3.41	48.85	54.00	-5.15	AVG			

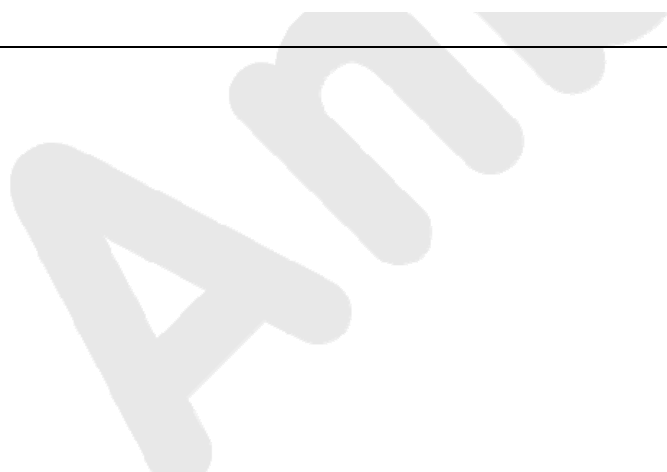

Job No.:	AT1311756F	Polarization:	Vertical
Standard:	(RE)FCC PART15 C_3m	Power Source:	AC 120V/60Hz for adapter
Test item:	Radiation Test	Test By:	Rock Zeng
Temp.(C)/Hum.(%RH):	24.3(C)/55%RH	Distance:	3m
Note:	802.11b(2437Mhz)		

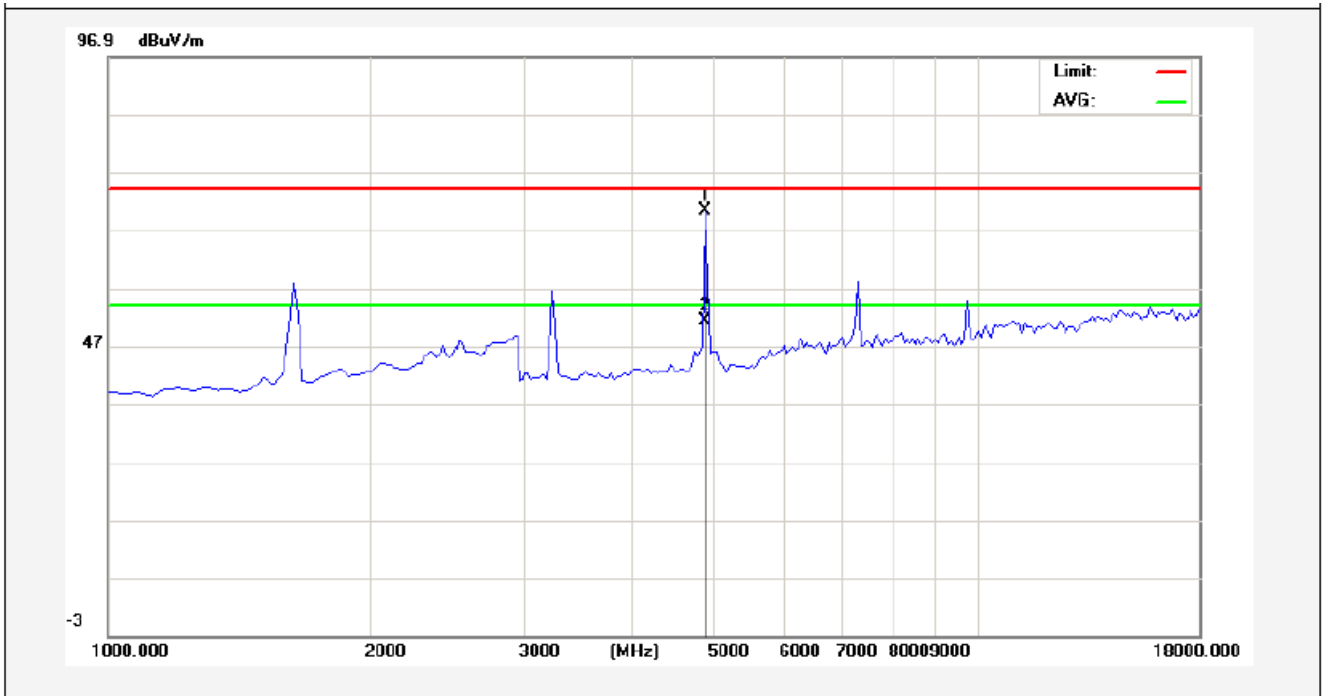

No.	Freq. (MHz)	Reading (dBuV/m)	Factor (dB/m)	Result (dBuV/m)	Limit (dBuV/)	Over Limit (dB)	Detector	Height (cm)	degree (deg)	Remark
1	4867.500	66.84	3.41	70.25	74.00	-3.75	peak			
2	4867.500	47.96	3.41	51.37	54.00	-2.63	AVG			

AEM

Job No.:	AT1311756F	Polarization:	Horizontal
Standard:	(RE)FCC PART15 C_3m	Power Source:	AC 120V/60Hz for adapter
Test item:	Radiation Test	Test By:	Rock Zeng
Temp.(C)/Hum.(%RH):	24.3(C)/55%RH	Distance:	3m
Note:	802.11b(2462Mhz)		

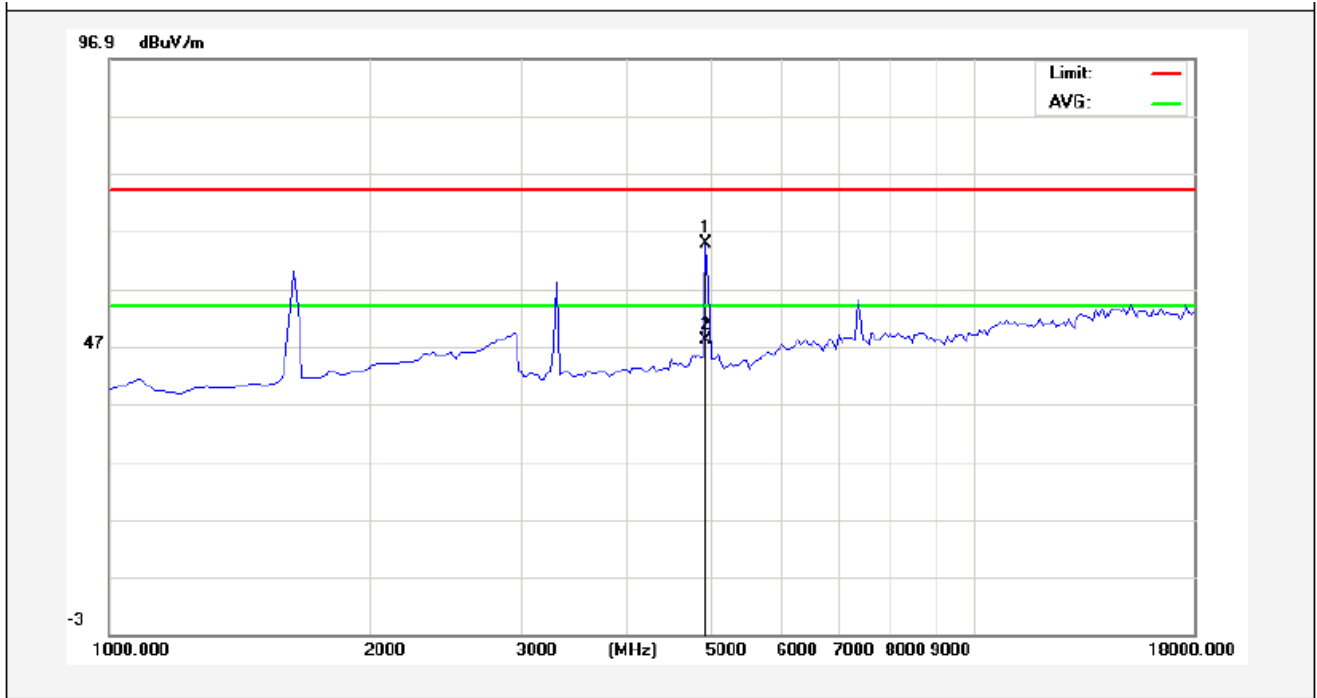

No.	Freq. (MHz)	Reading (dBuV/m)	Factor (dB/m)	Result (dBuV/m)	Limit (dBuV/)	Over Limit (dB)	Detector	Height (cm)	degree (deg)	Remark
1	4902.300	61.21	3.48	64.69	74.00	-9.31	peak			
2	4902.300	44.58	3.48	48.06	54.00	-5.94	AVG			

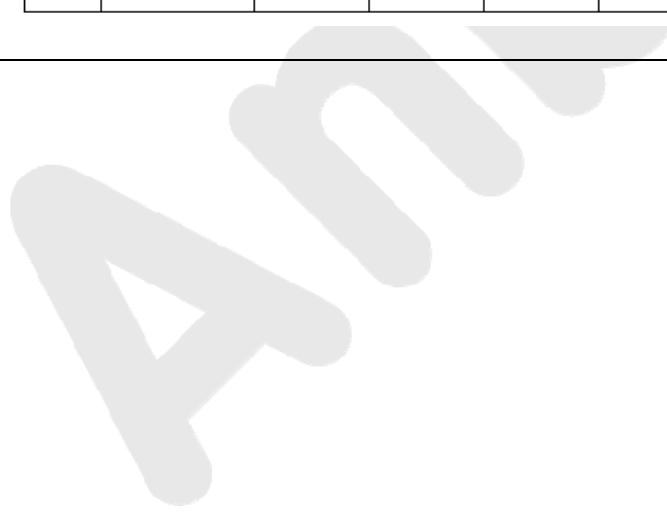

Job No.:	AT1311756F	Polarization:	Vertical
Standard:	(RE)FCC PART15 C_3m	Power Source:	AC 120V/60Hz for adapter
Test item:	Radiation Test	Test By:	Rock Zeng
Temp.(C)/Hum.(%RH):	24.3(C)/55%RH	Distance:	3m
Note:	802.11b(2462Mhz)		

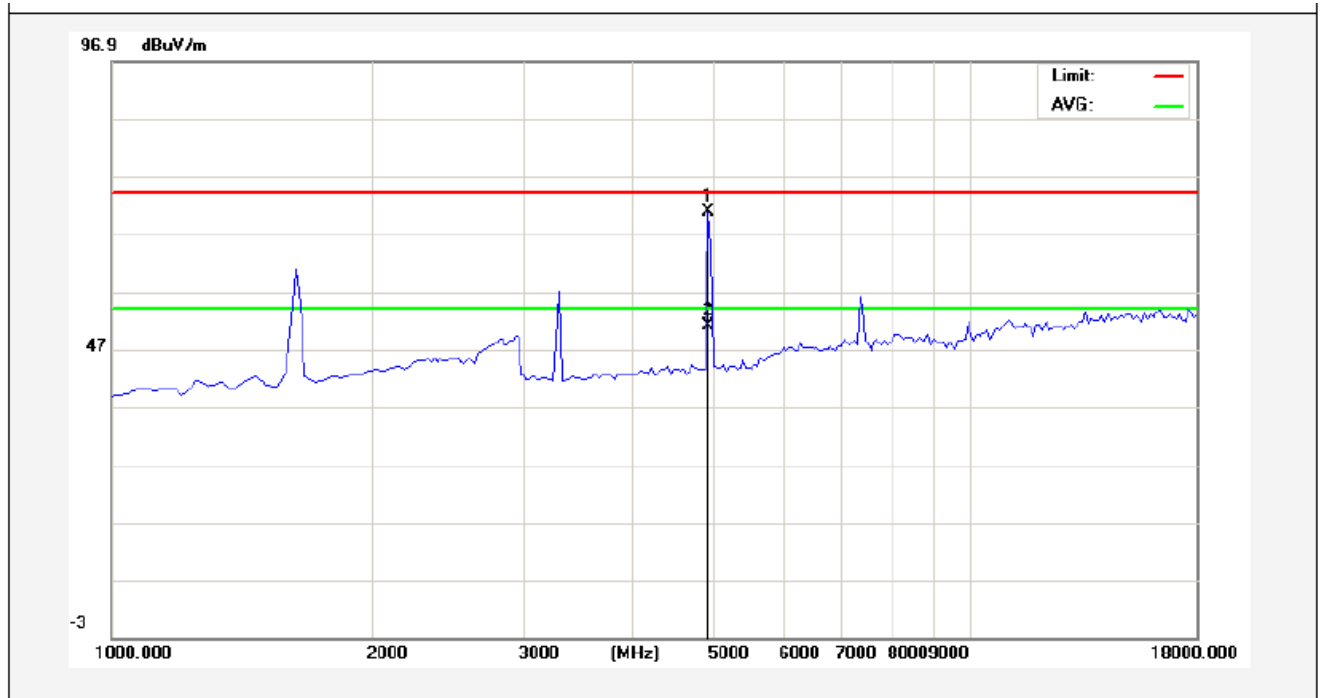

No.	Freq. (MHz)	Reading (dBuV/m)	Factor (dB/m)	Result (dBuV/m)	Limit (dBuV/)	Over Limit (dB)	Detector	Height (cm)	degree (deg)	Remark
1	4910.000	67.26	3.49	70.75	74.00	-3.25	peak			
2	4910.000	47.45	3.49	50.94	54.00	-3.06	AVG			

5. PHOTOGRAPH

5.1. Photo of Conducted Emission Measurement



5.2. Photo of Radiation Emission Test

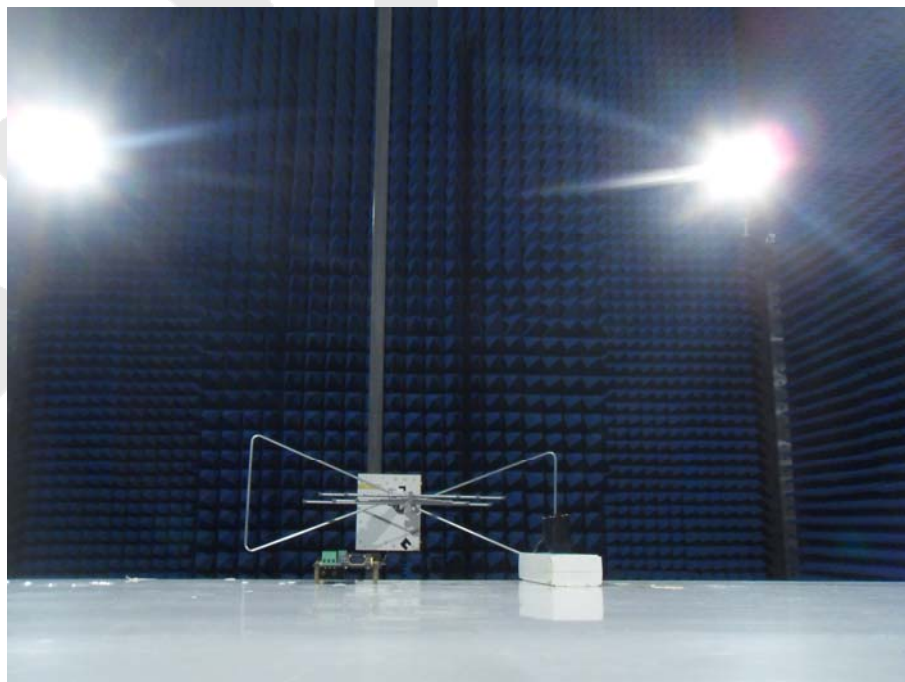

Appendix I (External Photos)

Figure 1
The EUT-Front View

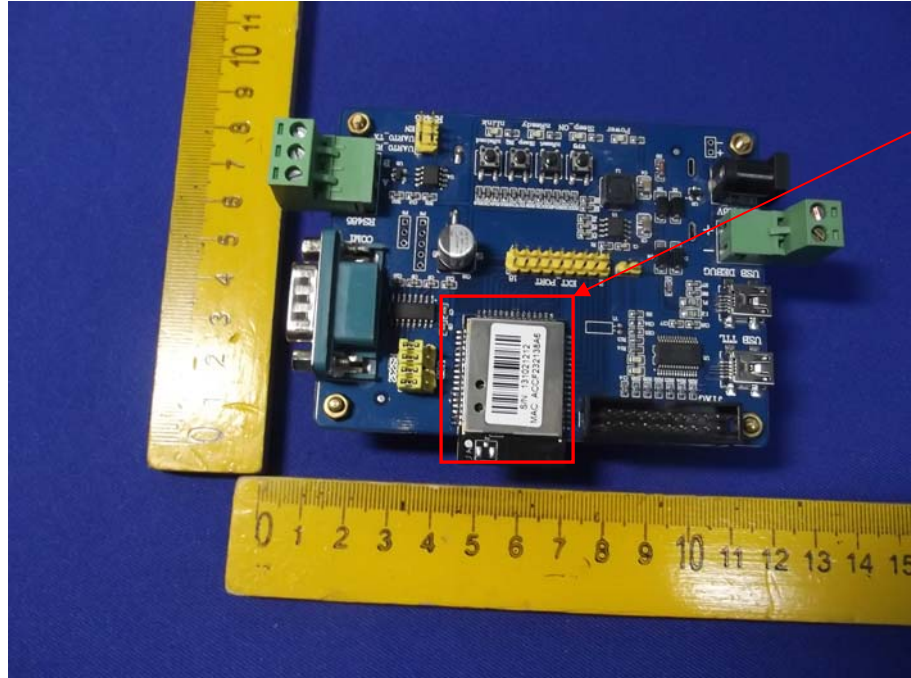

EUT is placed
on the host

Figure 2
The EUT-Back View

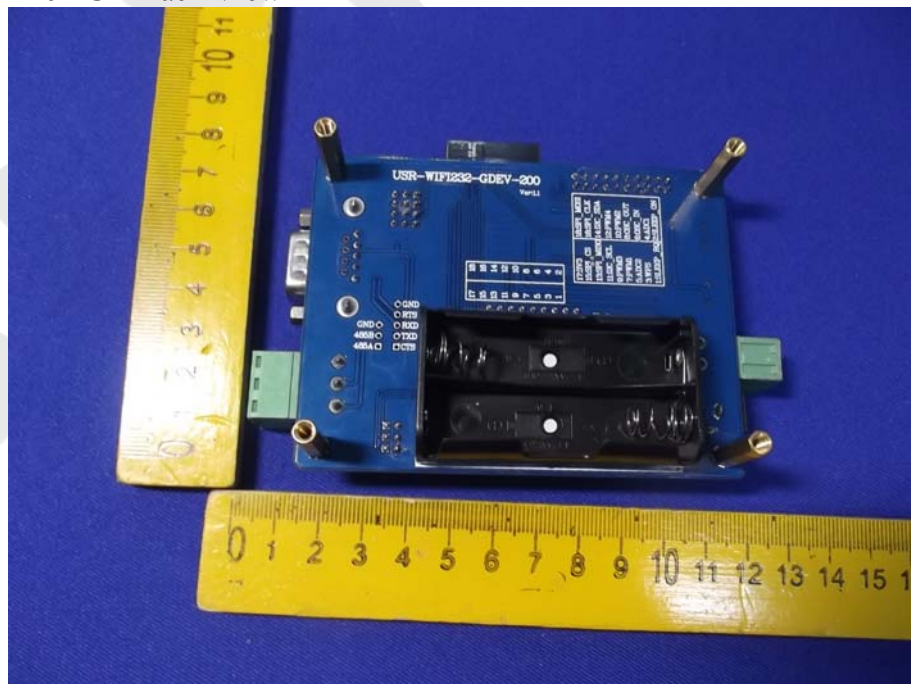
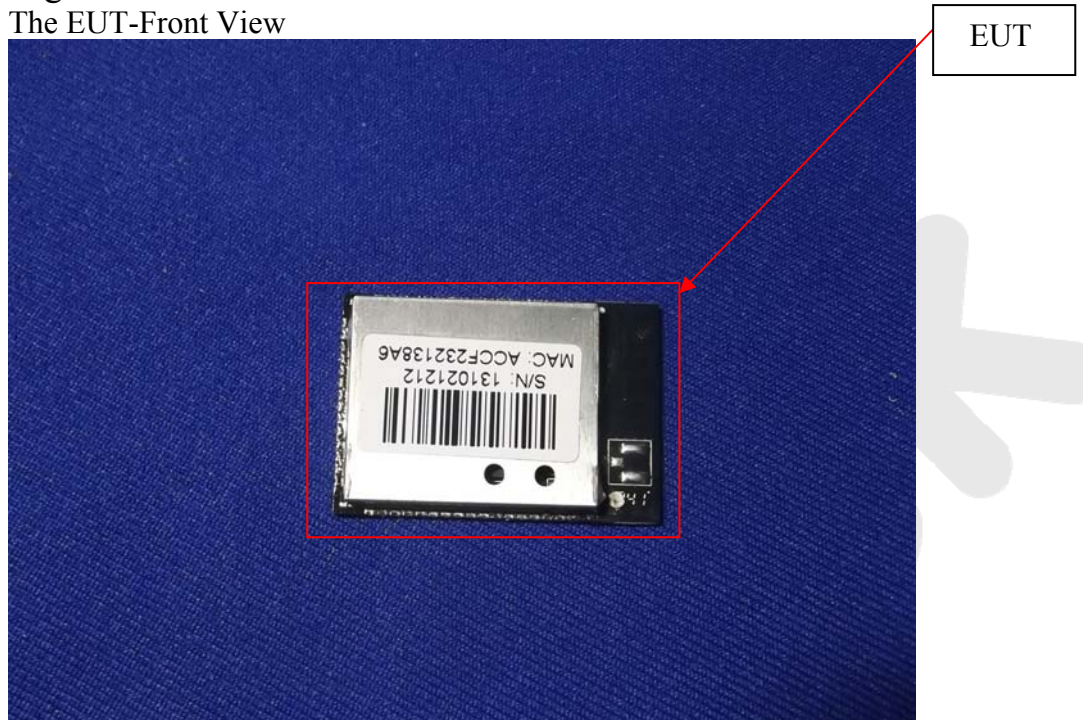

Figure 3
The EUT-Front View



Appendix II (Internal Photos)

Figure 4
The EUT-Inside View

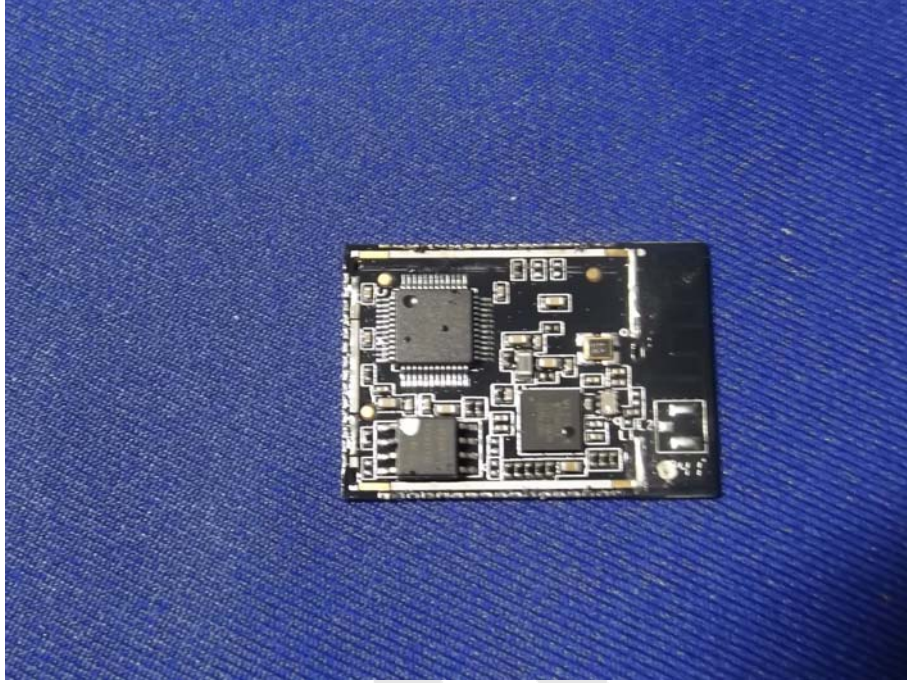

Figure 5
The EUT-Inside View

